

❧ Book of Traceable Heraldic Art ❧

Volume 4:

Ordinaries

Including Couped Varieties

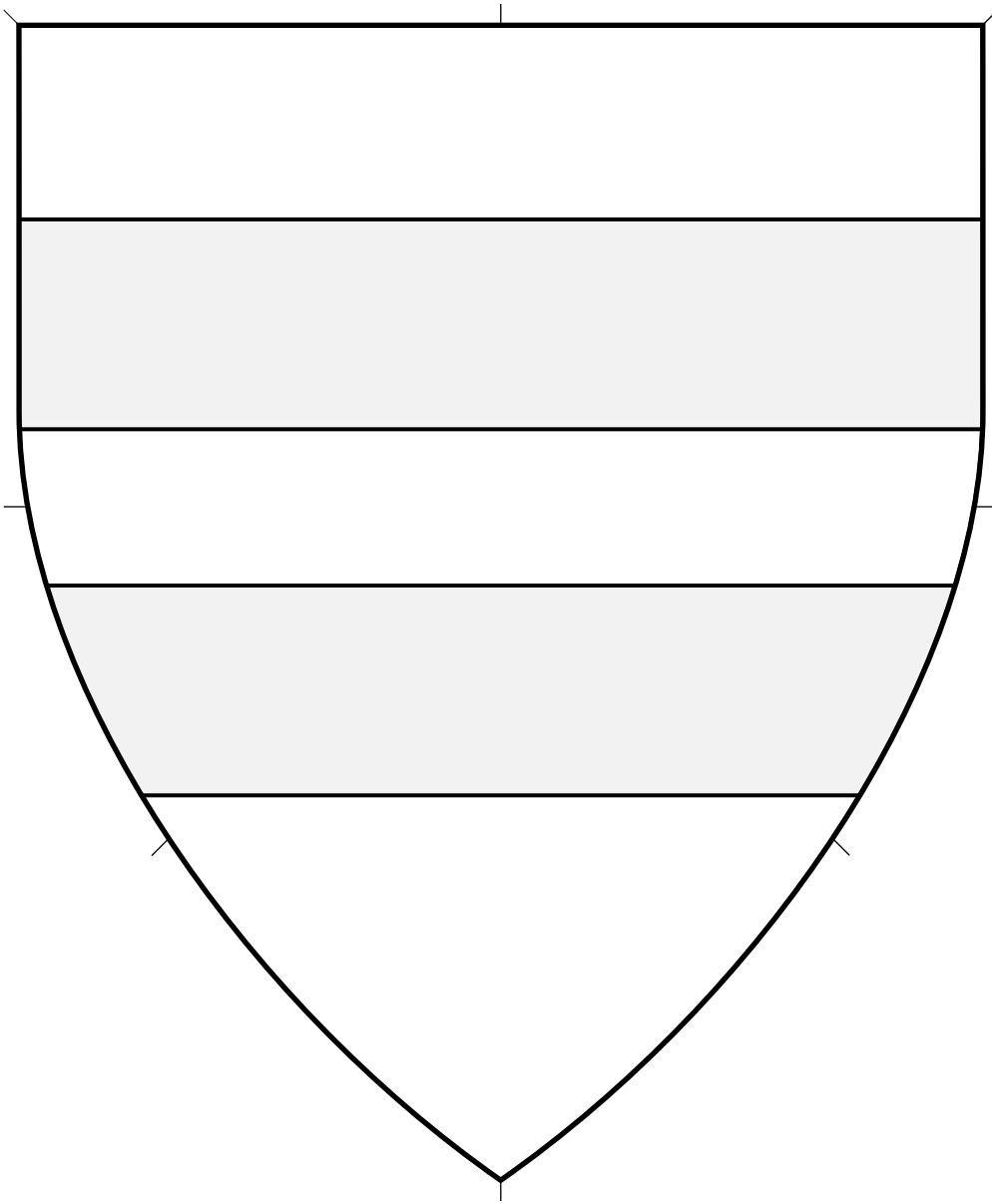

Central ordinary.

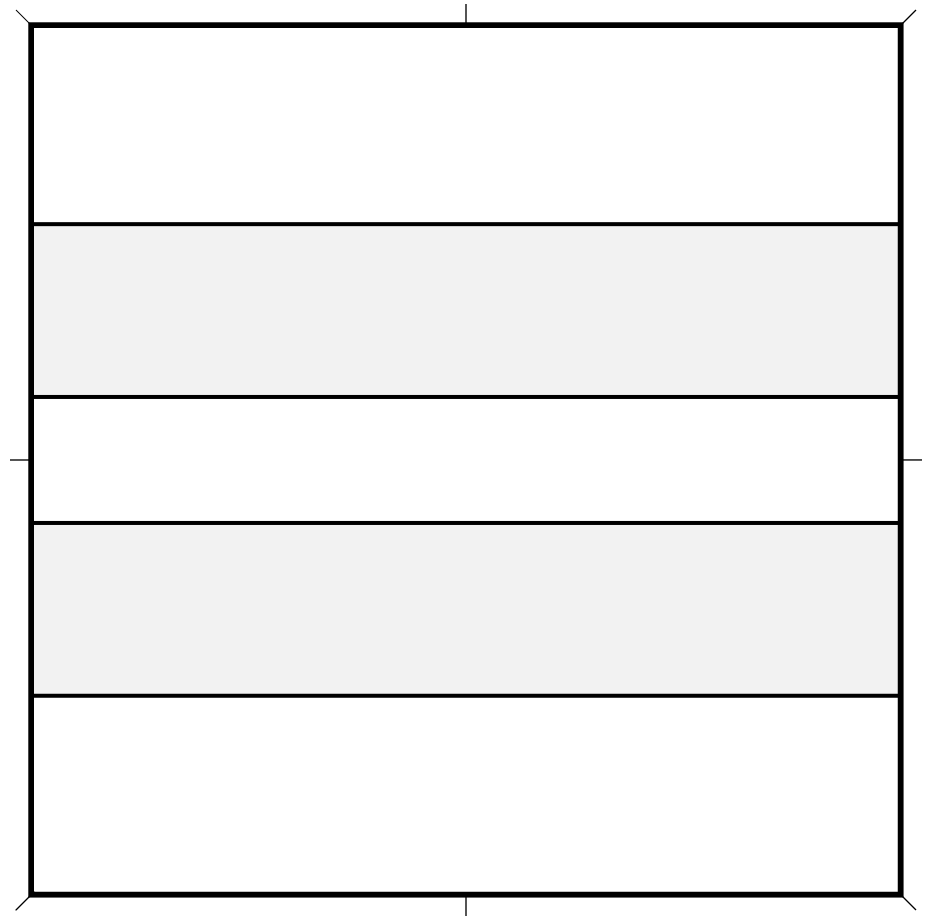

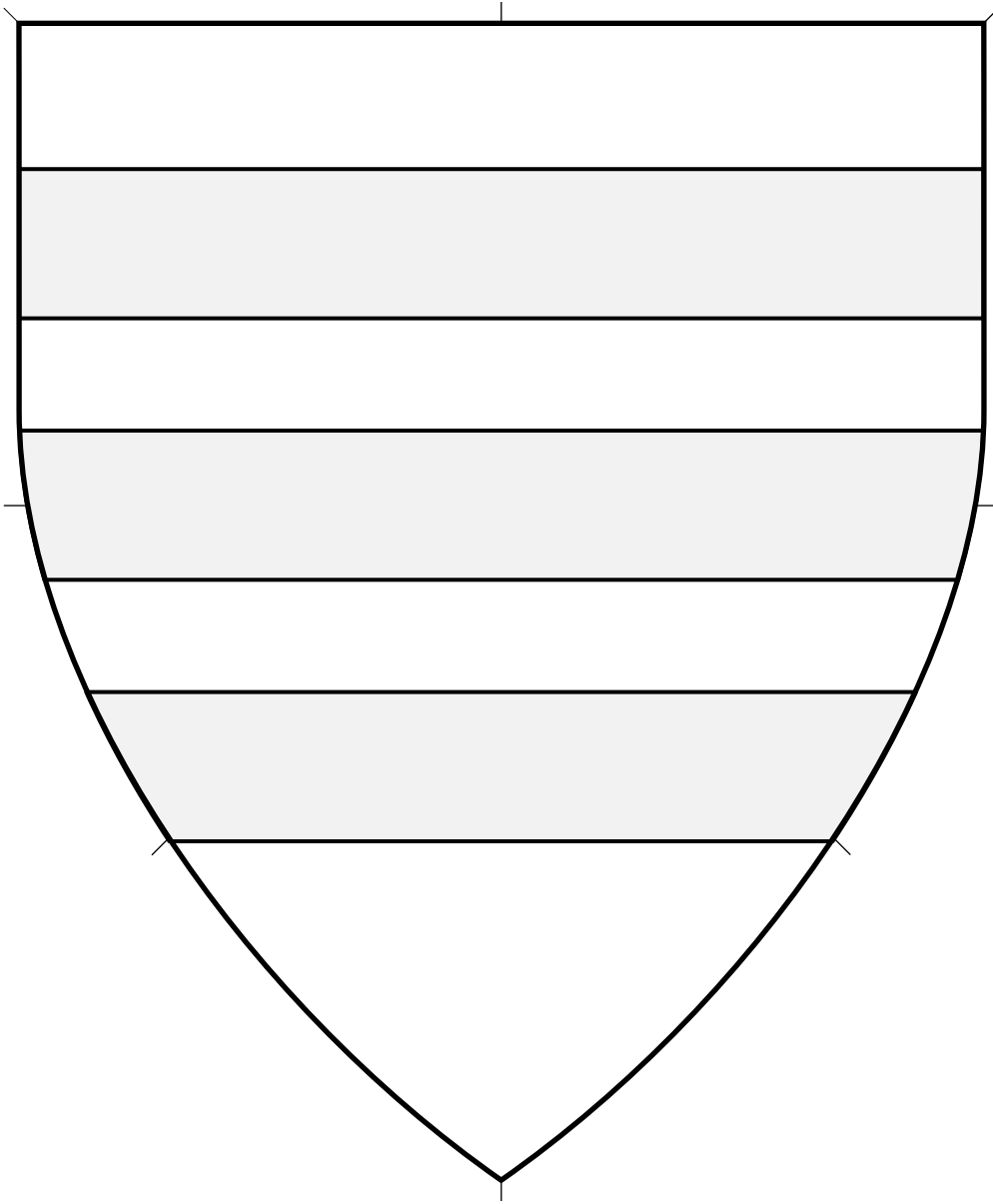

Central ordinary.

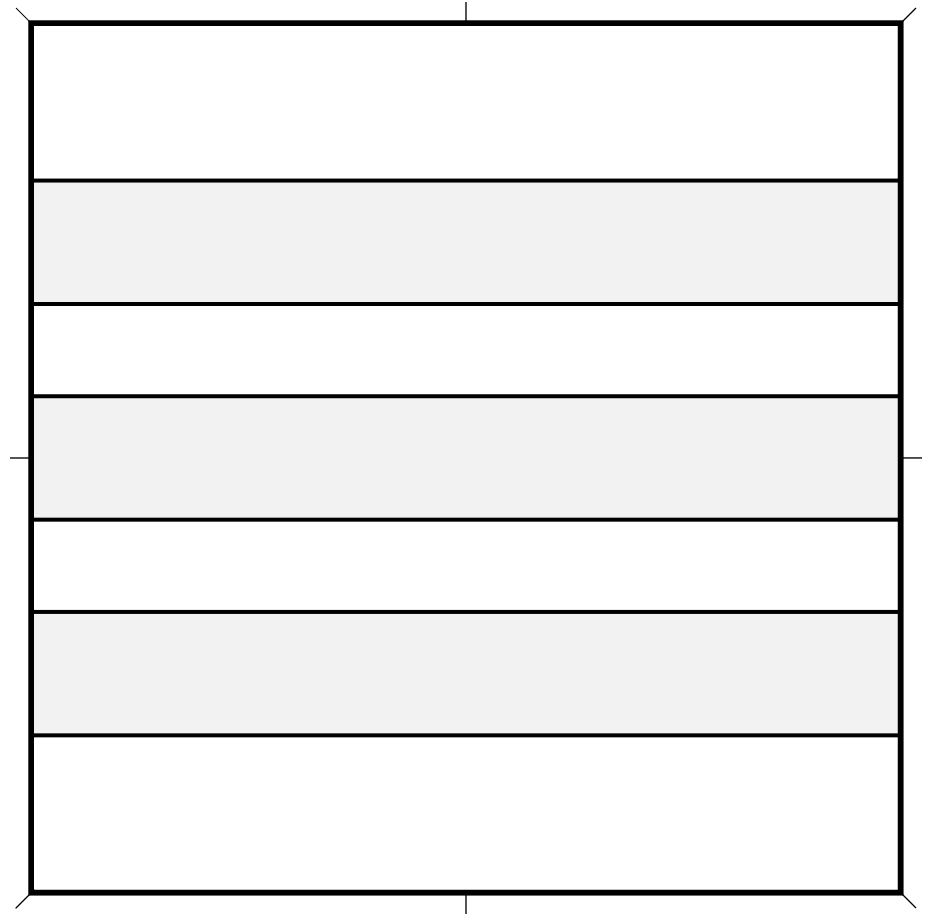

Bars, Three 4.3

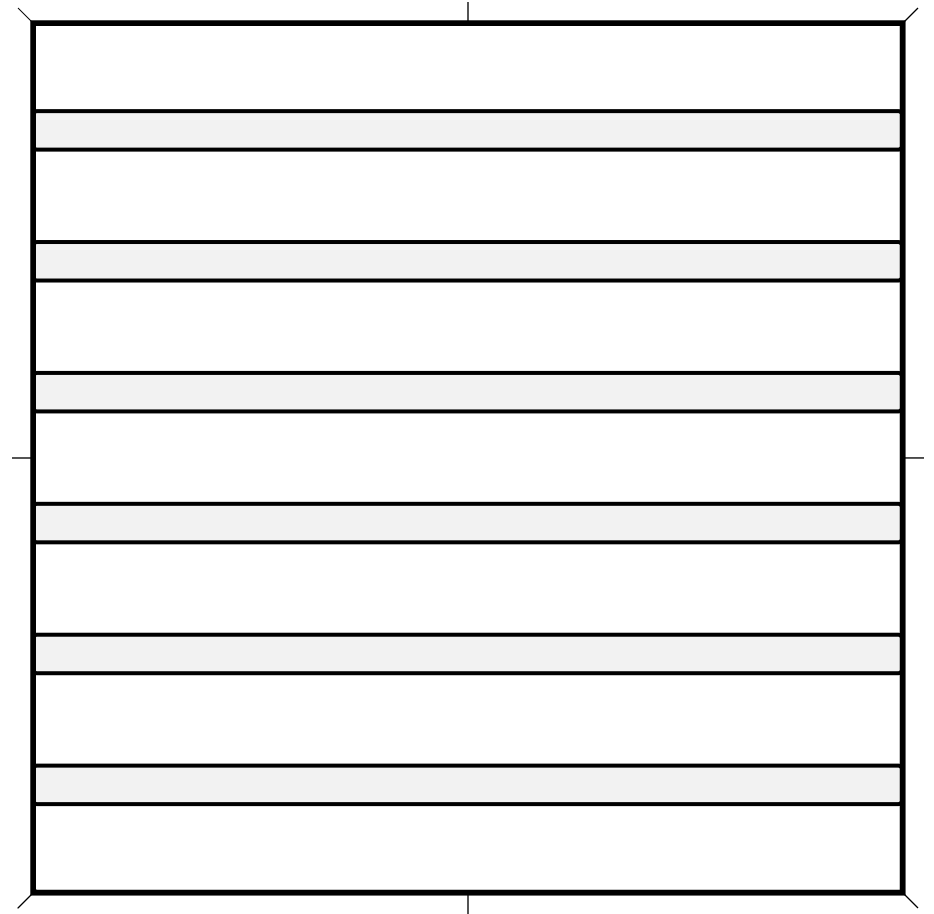
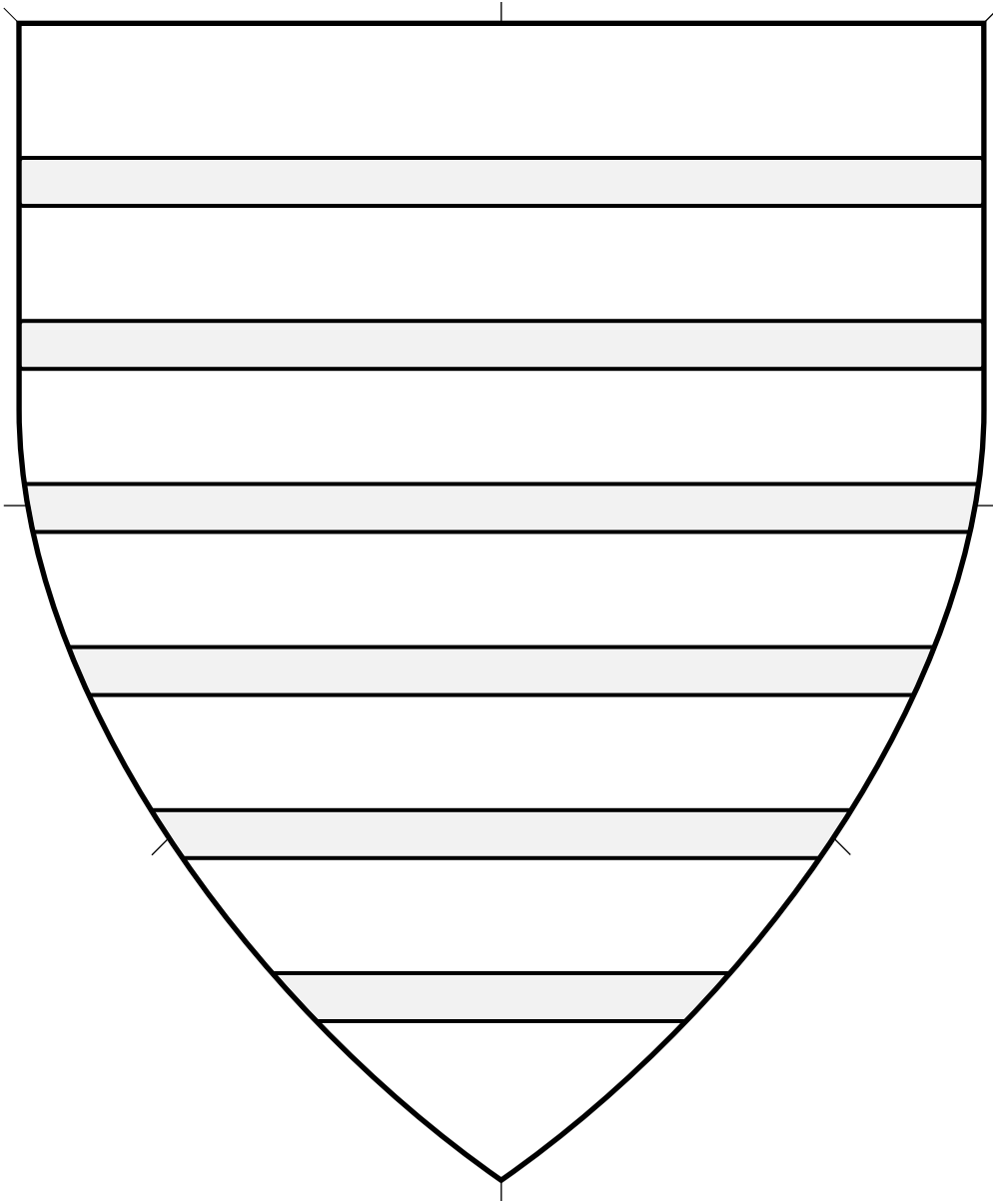

Central ordinary.

Source: Insignia Equitum Gallici Ordinis Sancti Michaelis.
Artist unknown. (Page 14.)

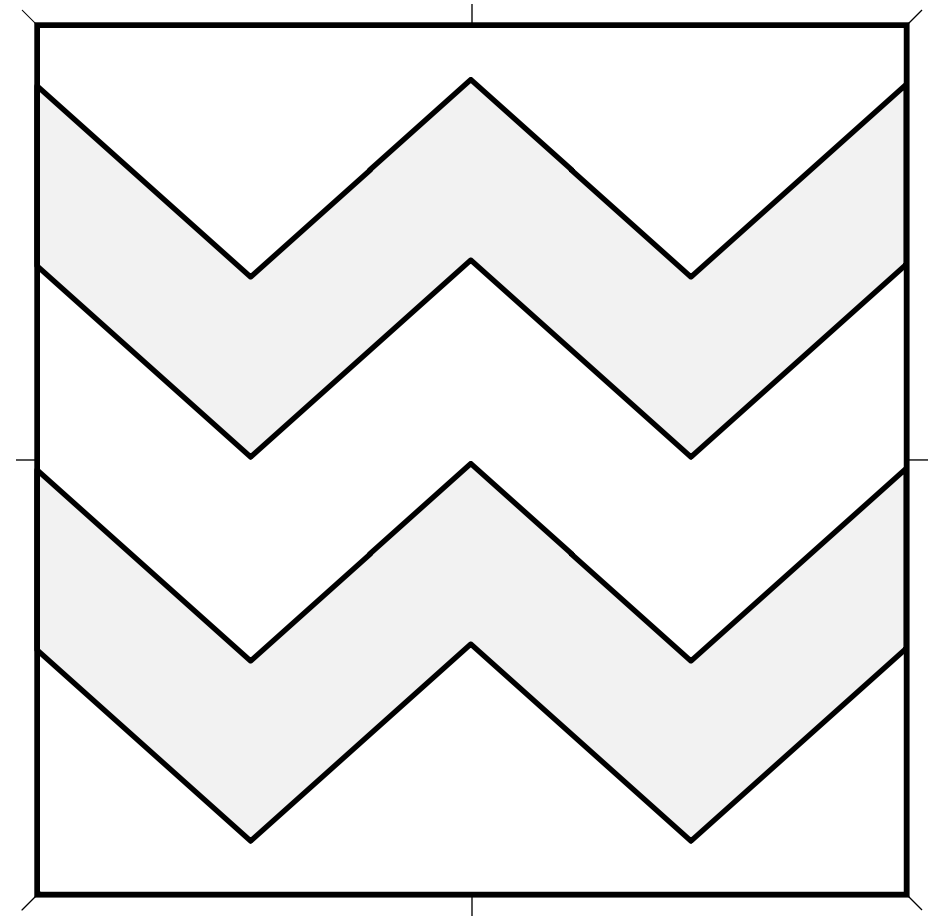
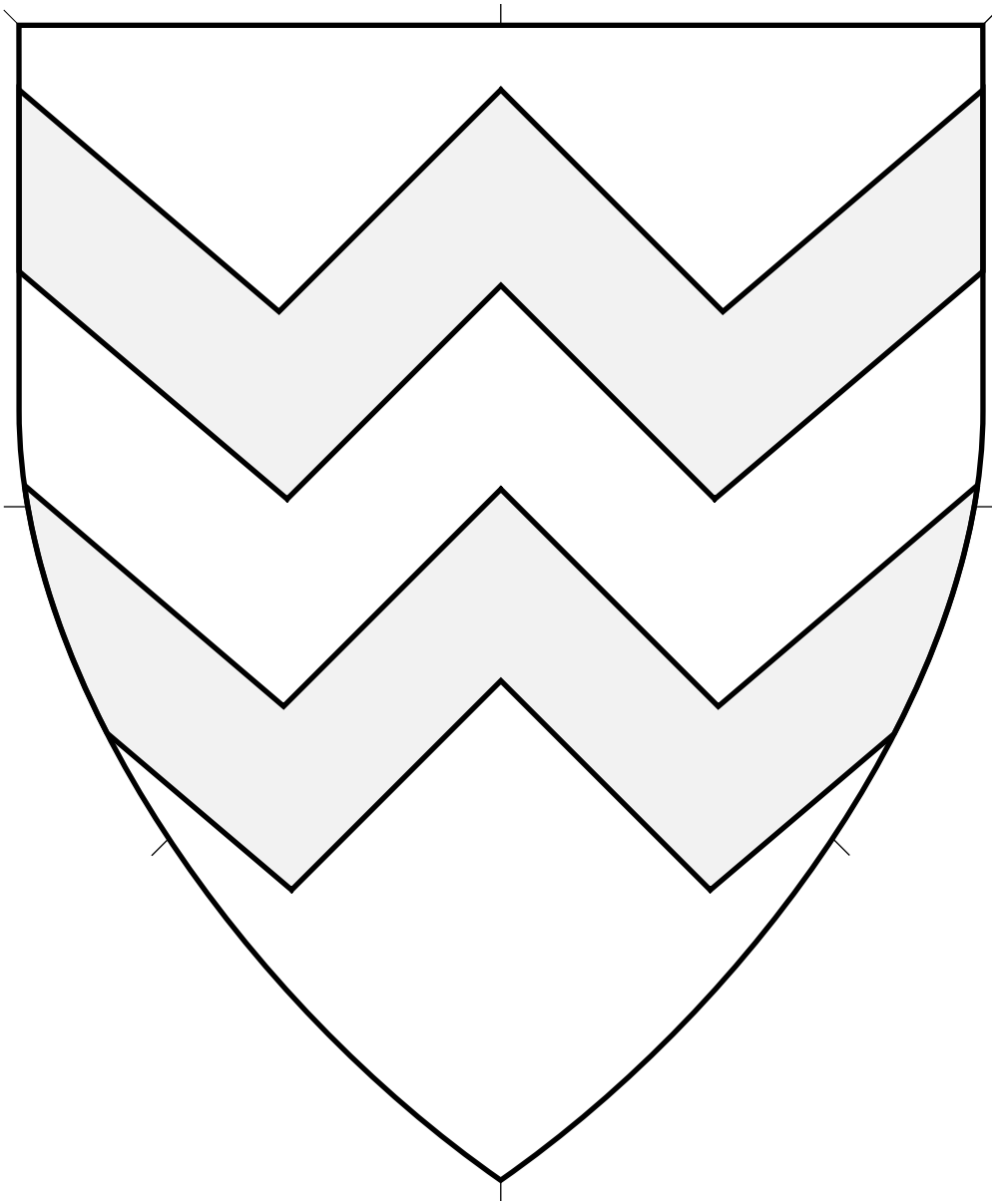

Central ordinary.

Source: Wappenbuch der Arlberg-Bruderschaft.
Artist: Vigil Raber. (Page 173.)

Bars Dancetty, Two (1) 4.5

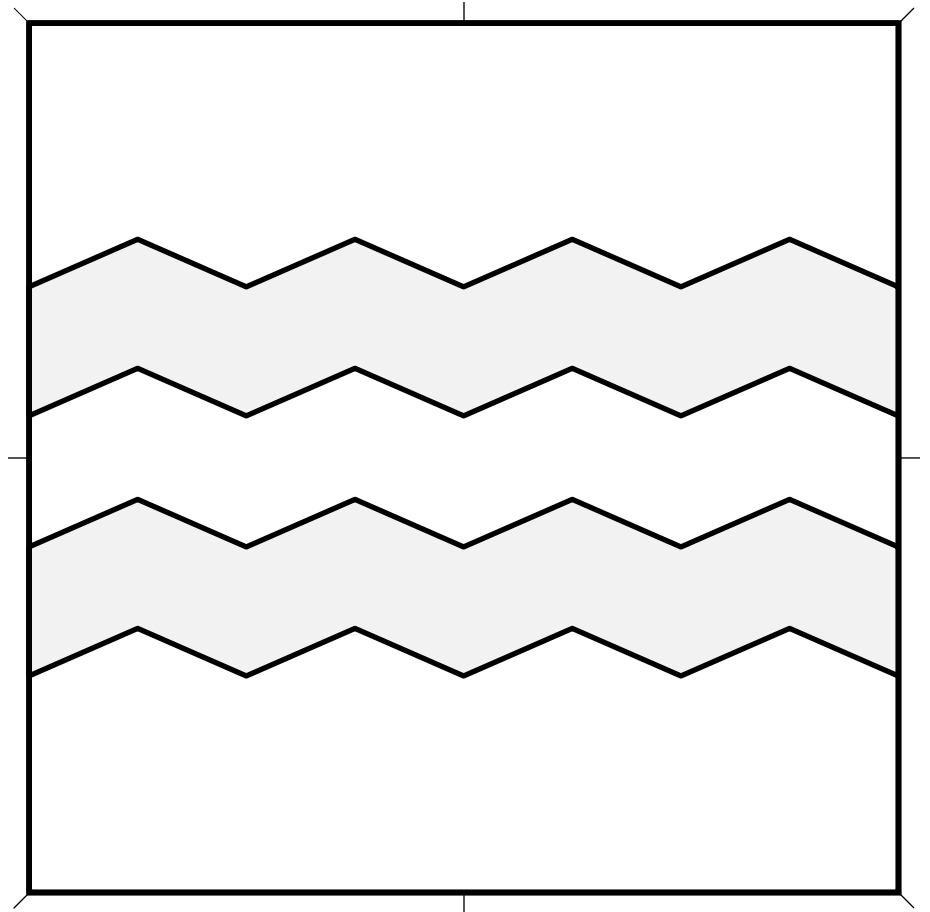
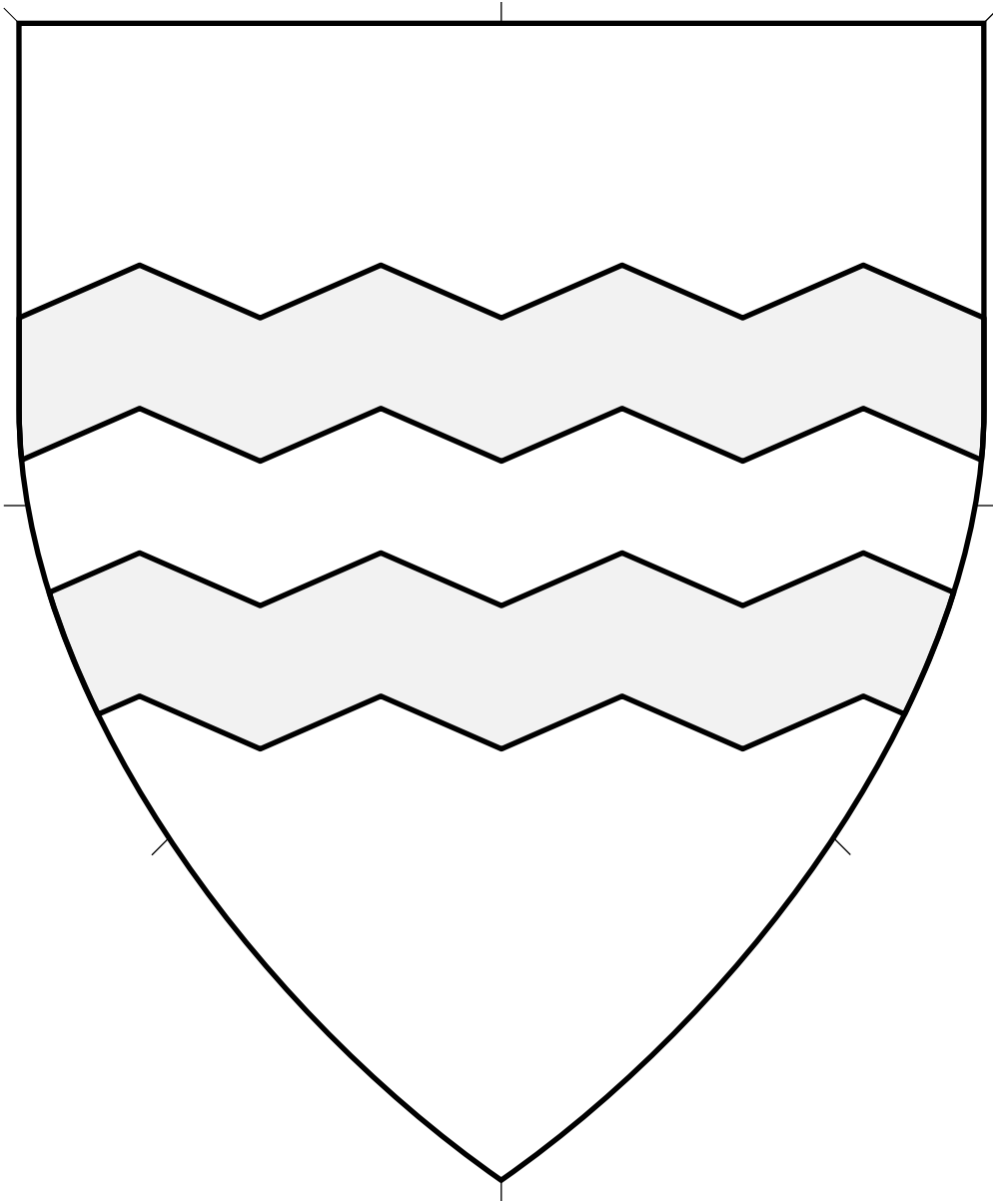

Central ordinary.

Source: Armorial General d'Europe.

Artist: Victor Rolland and Henri Rolland.

Bars Dancetty, Two (2) 4.6

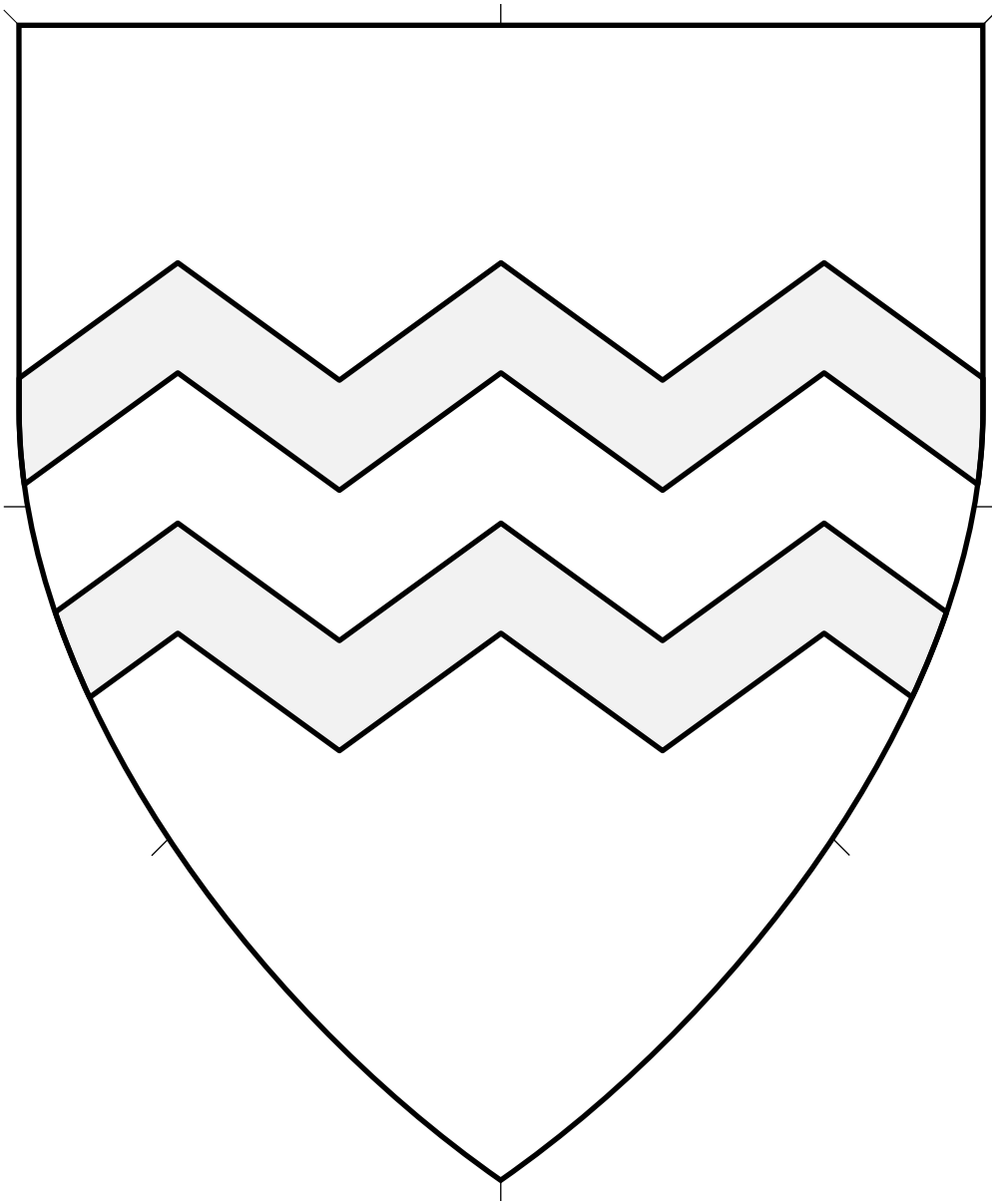

Central ordinary.

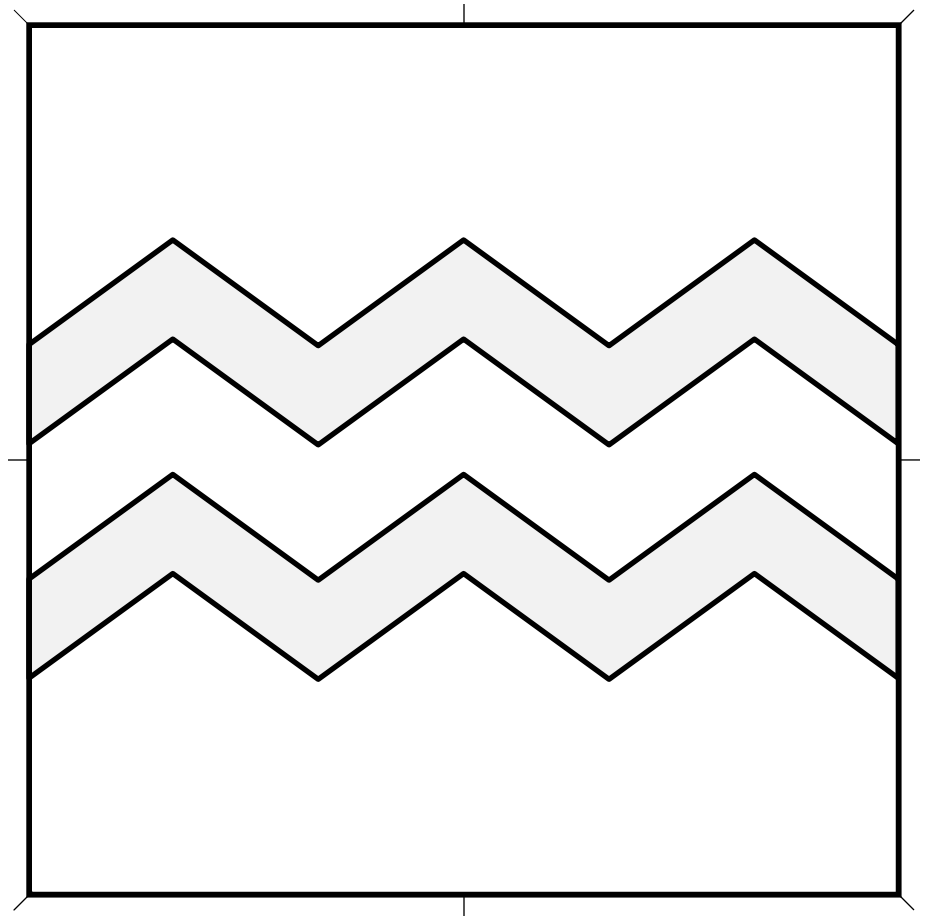

Bars Dancetty, Two (3) 4.7

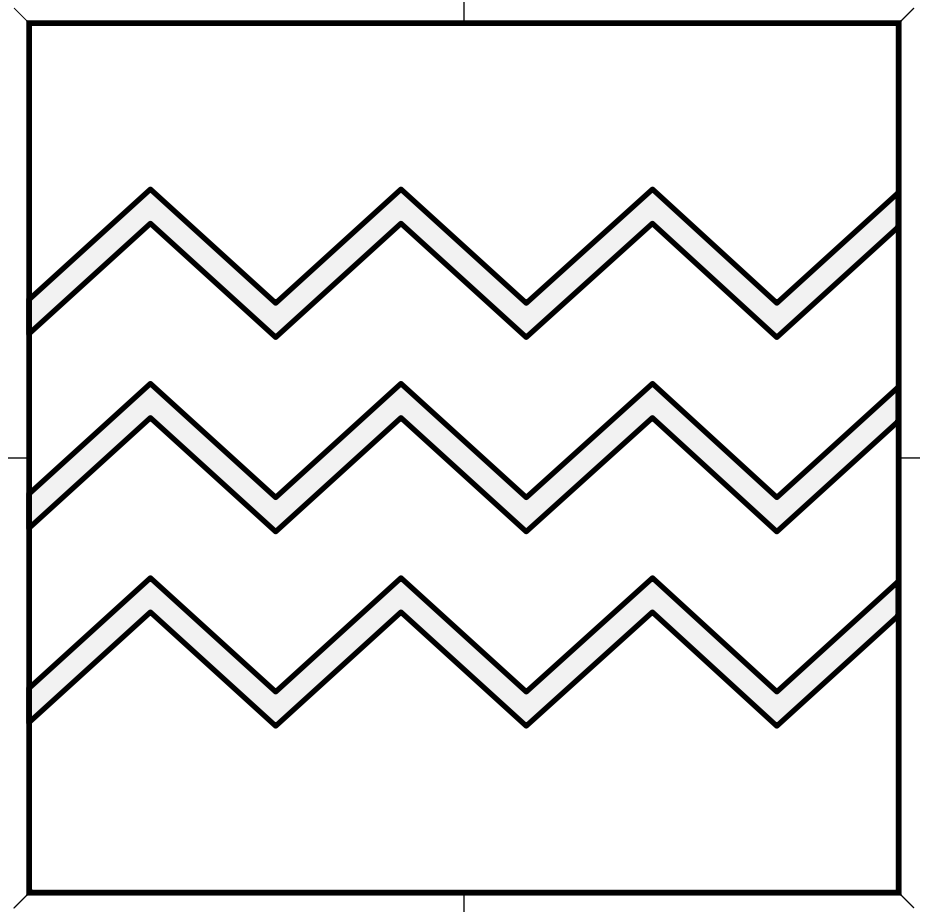
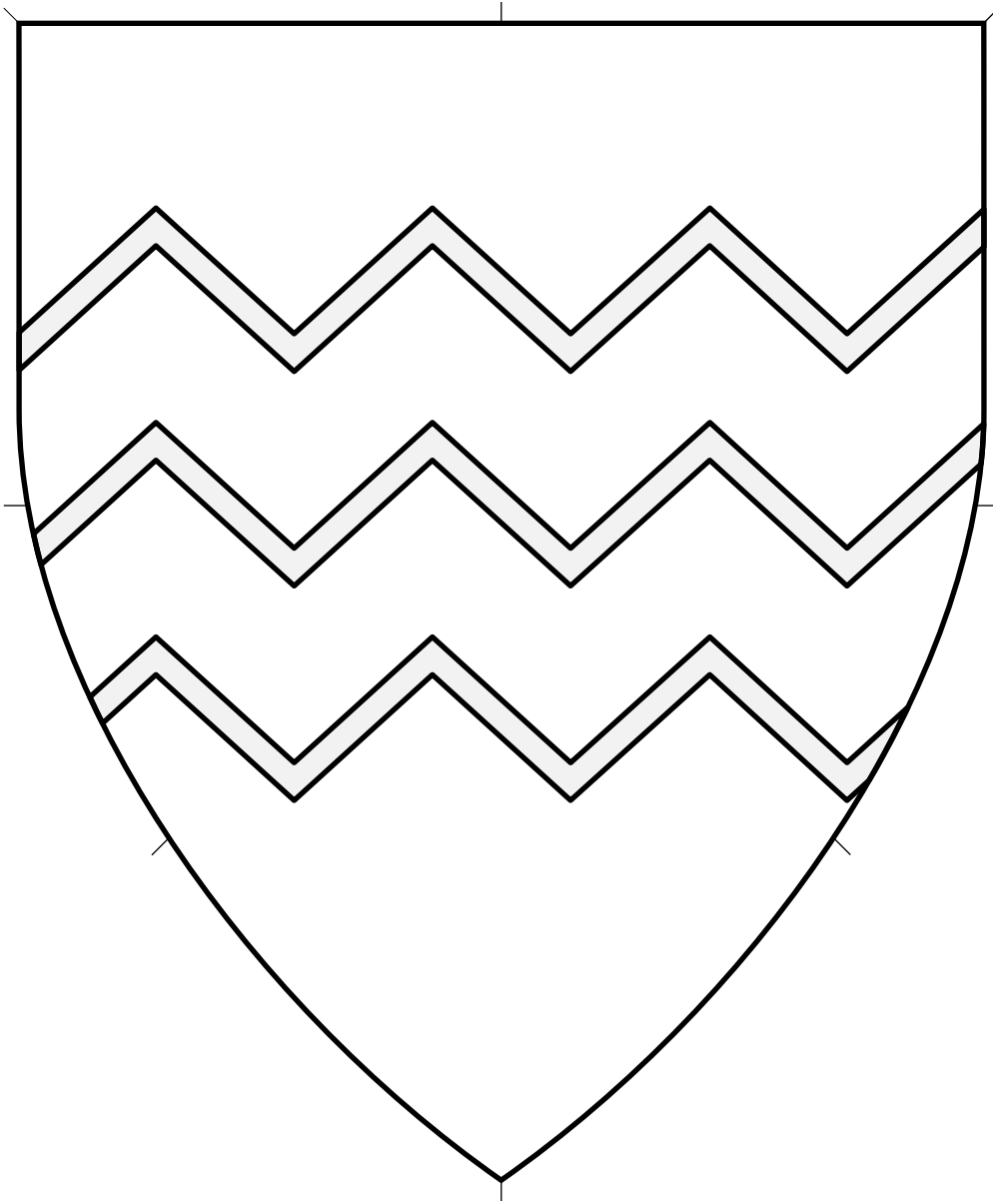

Central ordinary.

Source: Commonplace Book of Heraldry. (Folio 16r.)
Artist: Jean Faucket. Adapted by Mathghamhain Ua Ruadháin.

Bars Dancetty, Three (1) 4.8

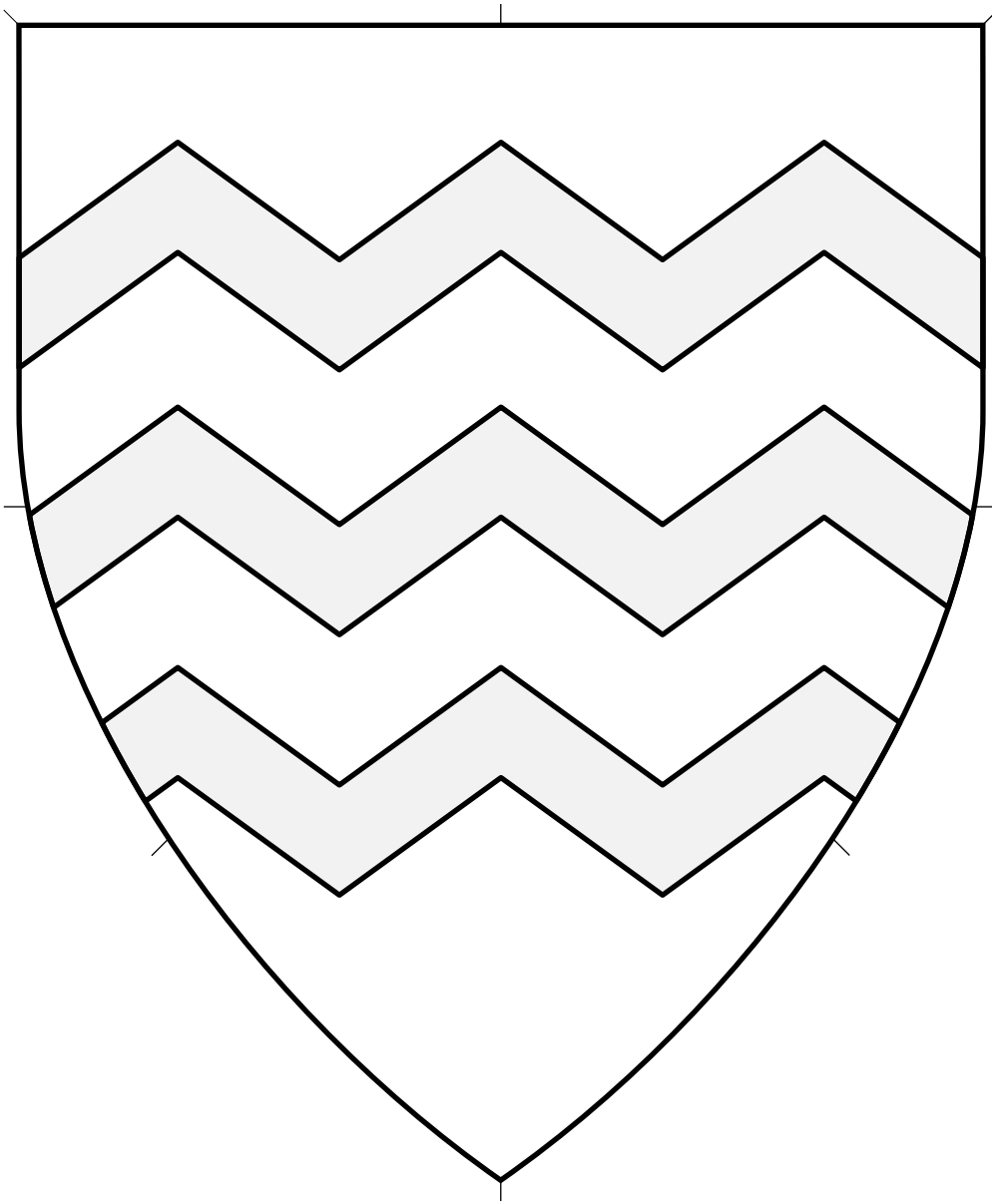

Central ordinary.

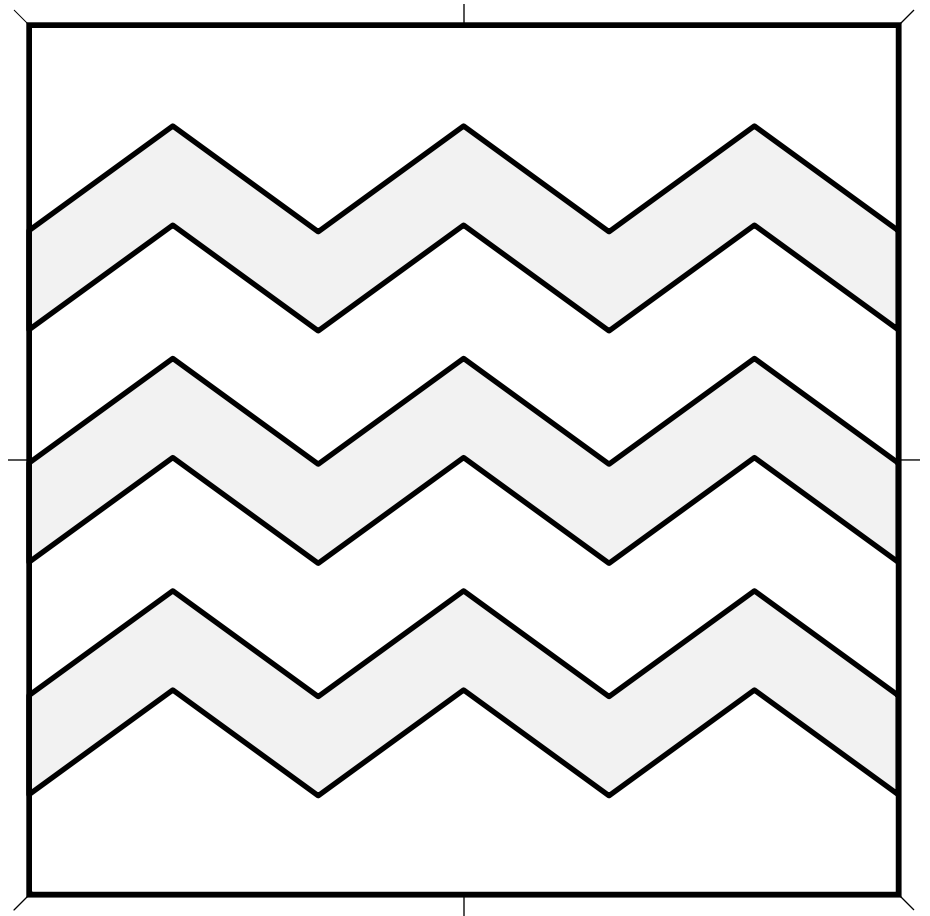

Bars Dancetty, Three (2) 4.9

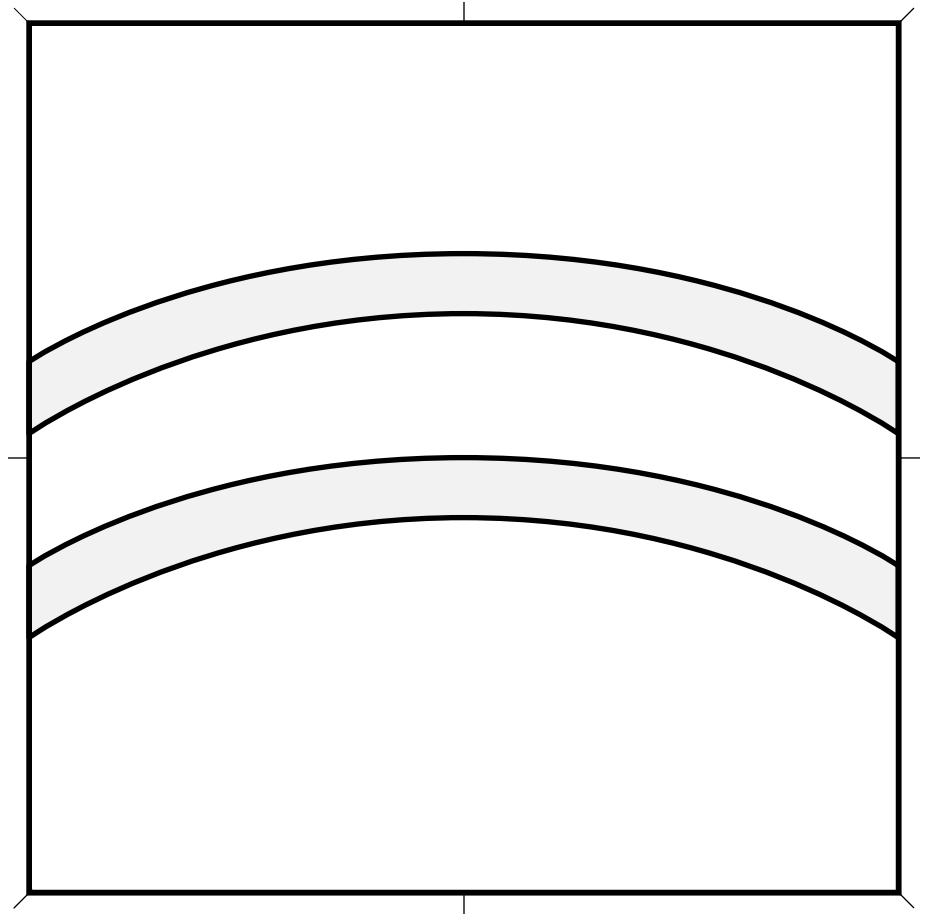
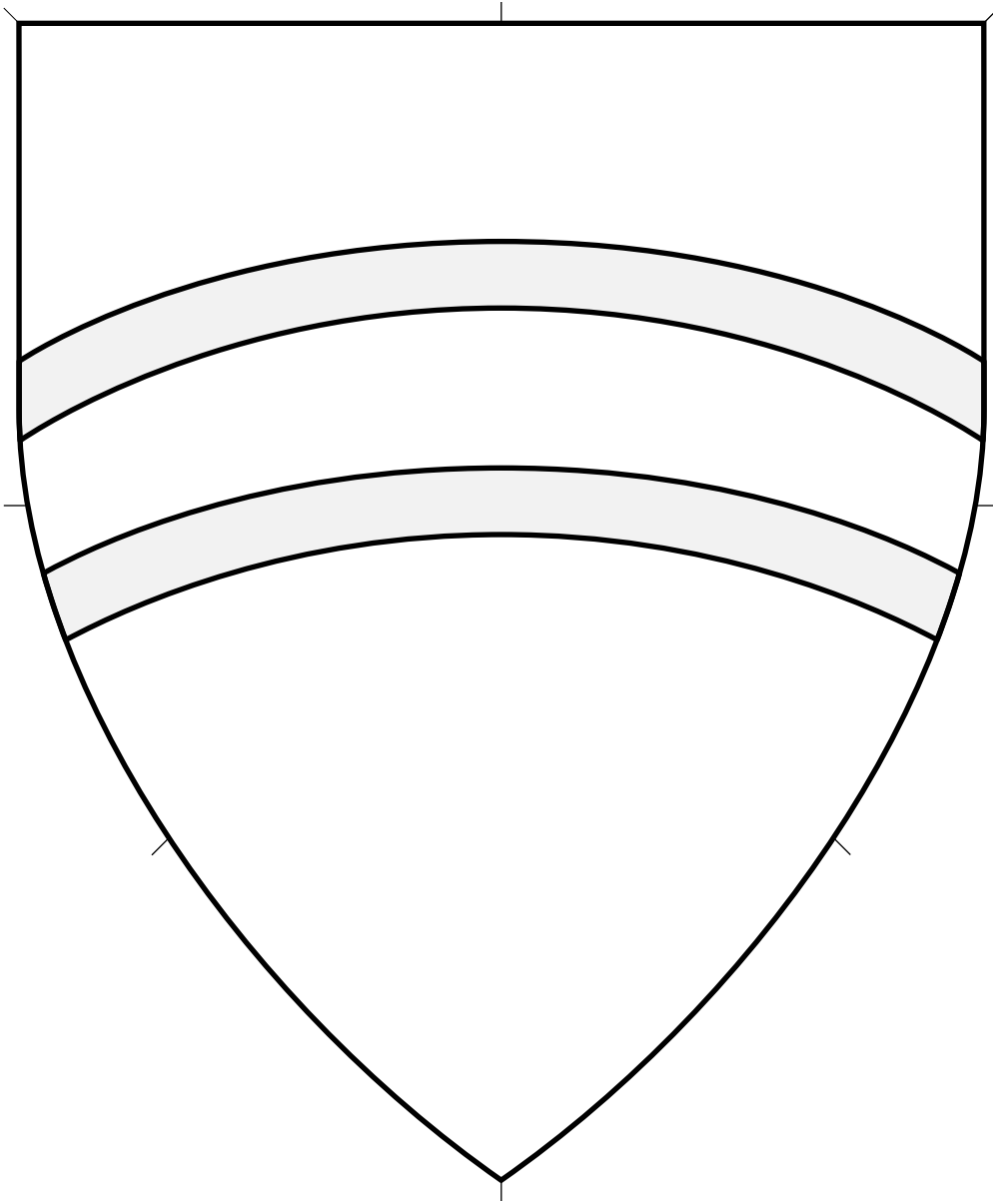

Central ordinary.

Source: BnF MS Allemand 304. Artist unknown. (Page 418.)

Bars Enarched, Two 4.10

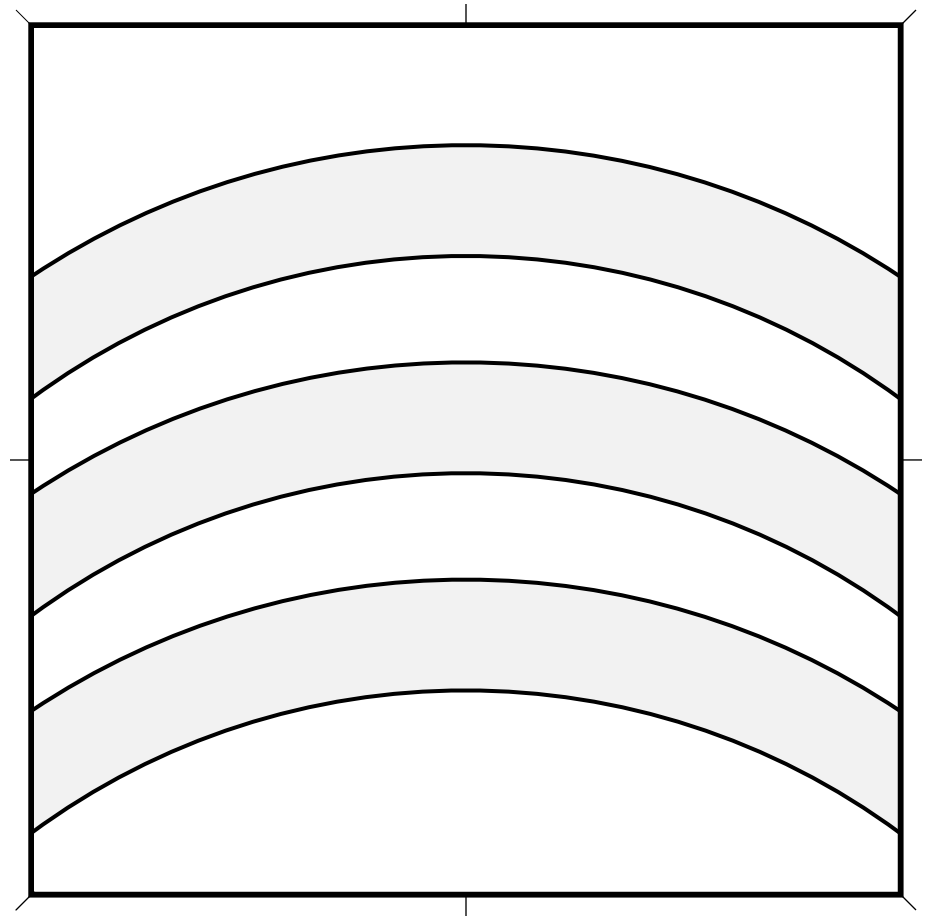
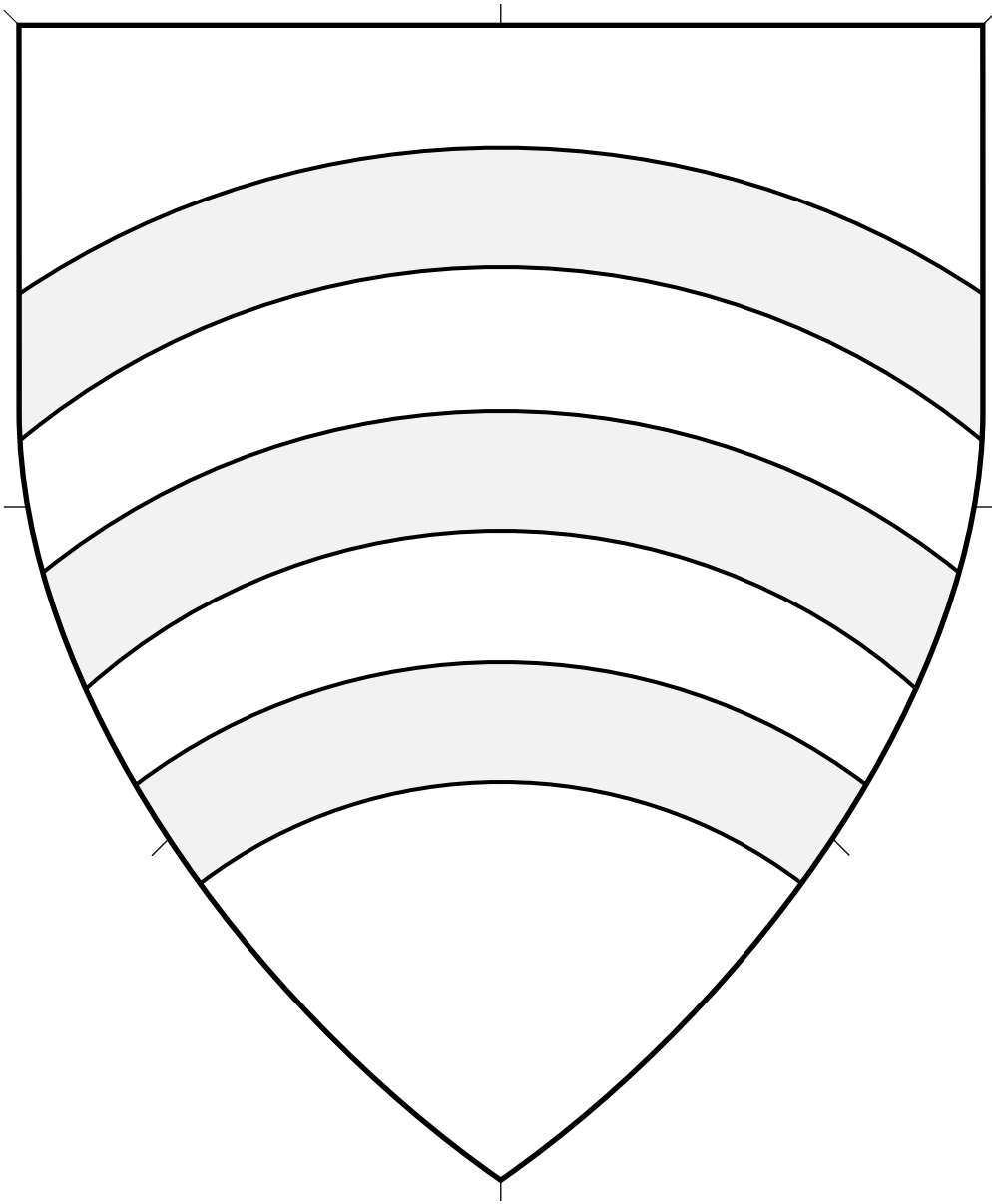

Central ordinary.

Source: Wapenboek van Gent. Artist: Vander Schelden.
(Volume 1, page 27.)

Bars Enarched, Three 4.11

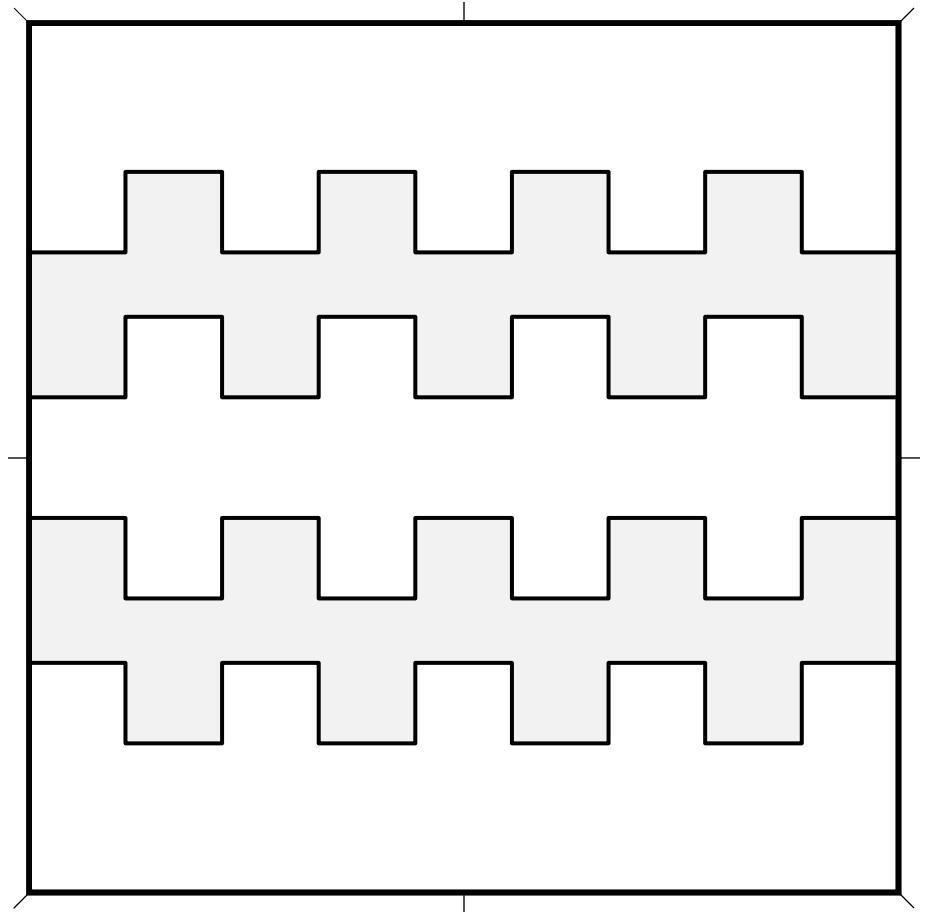
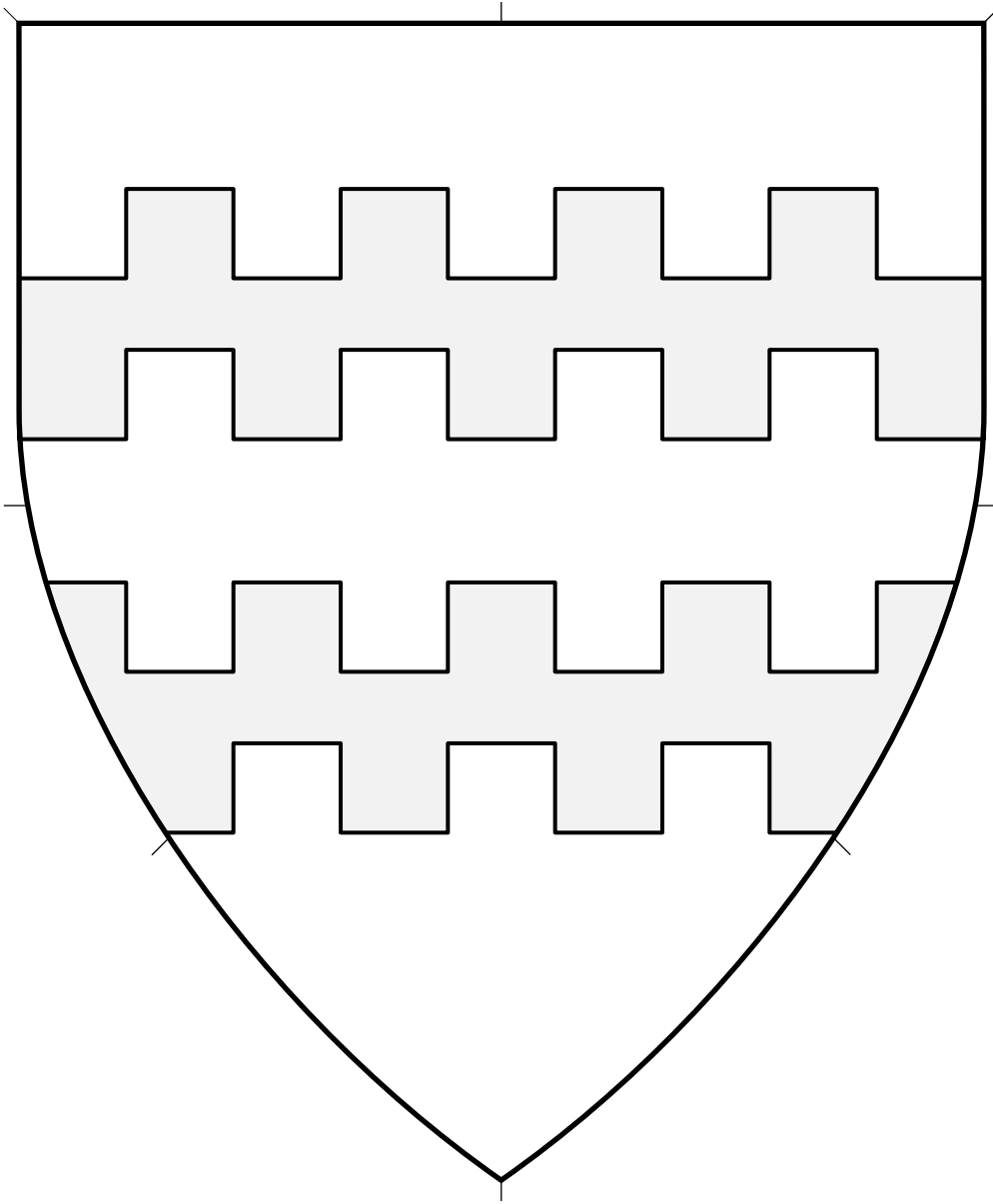

Central ordinary.

Source: BnF MS Allemand 304.
Artist unknown. (Folio 394v.)

Bars Embattled Counter-Embattled, 2 4.12

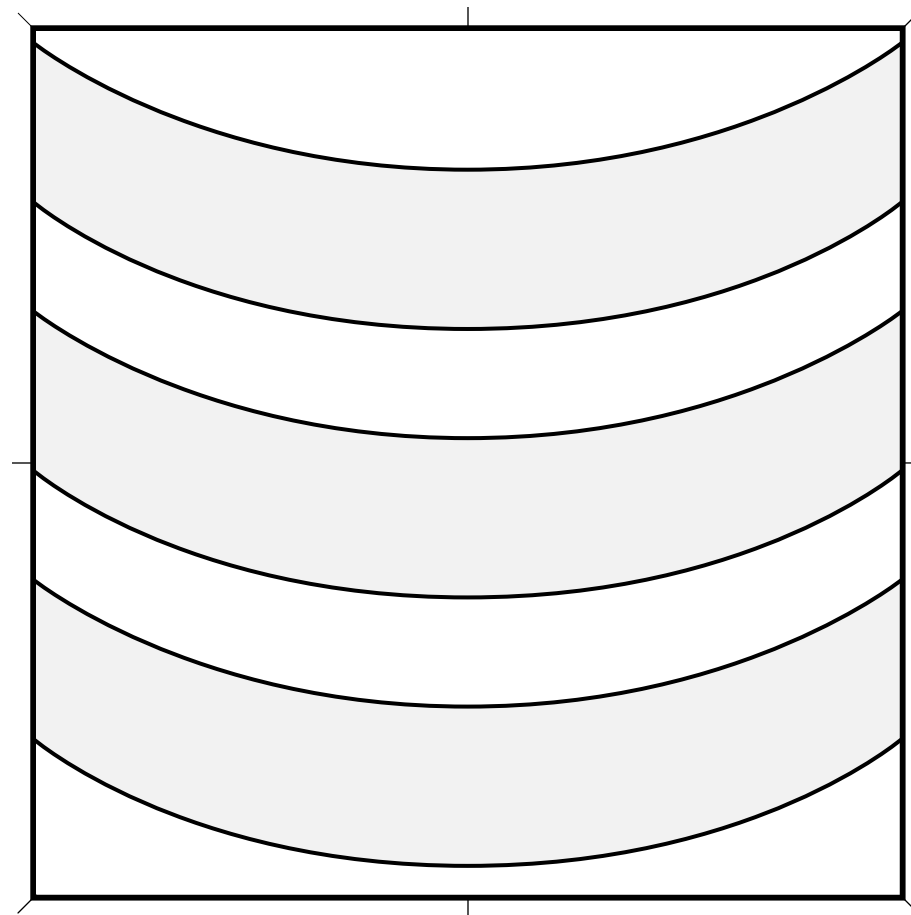
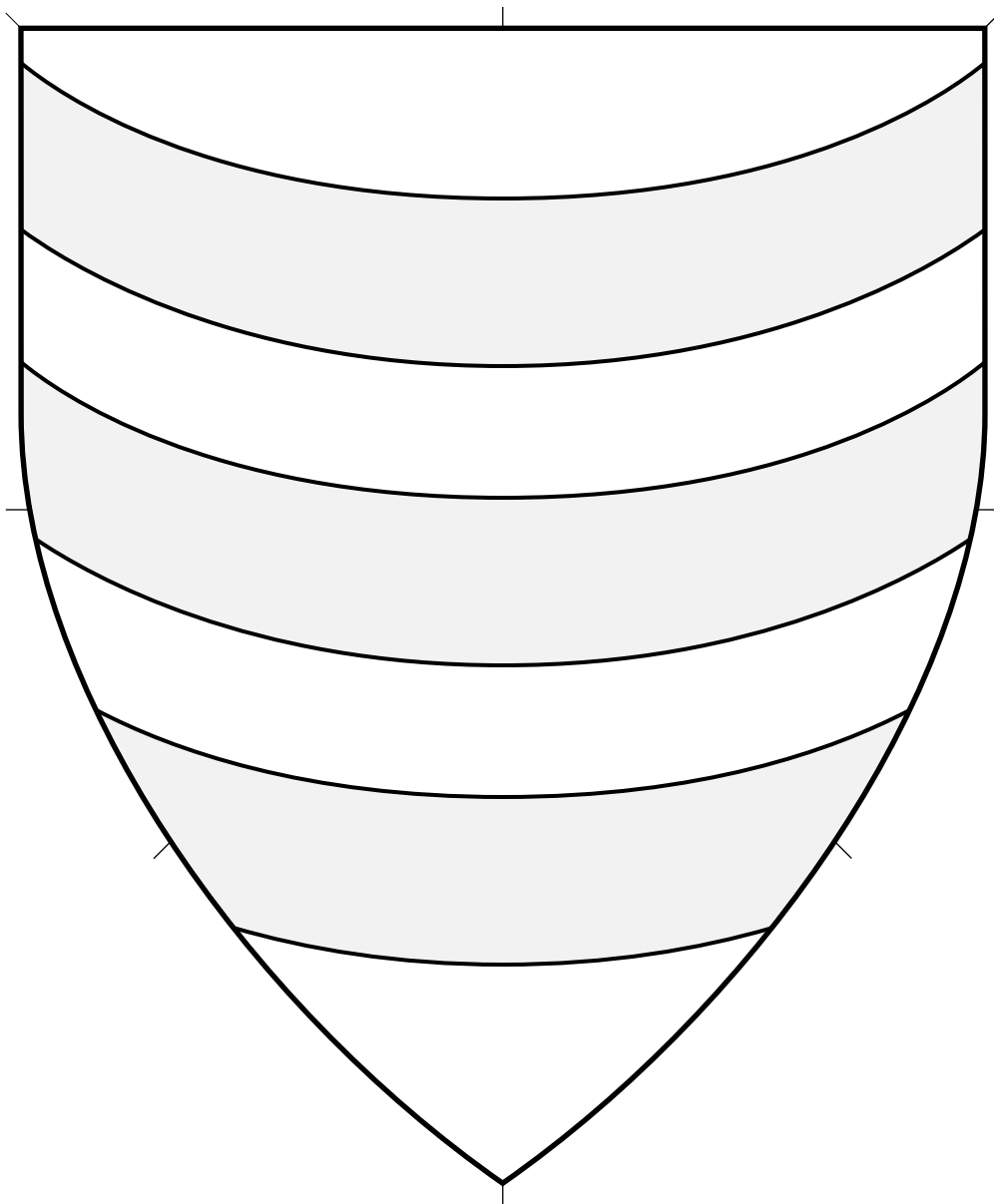

Central ordinary.

Source: Nobiliario de Armas de Valencia, Aragón y Cataluña. Artist unknown. (Folio 29v.)

Bars Embowed to Base, 3 4.13

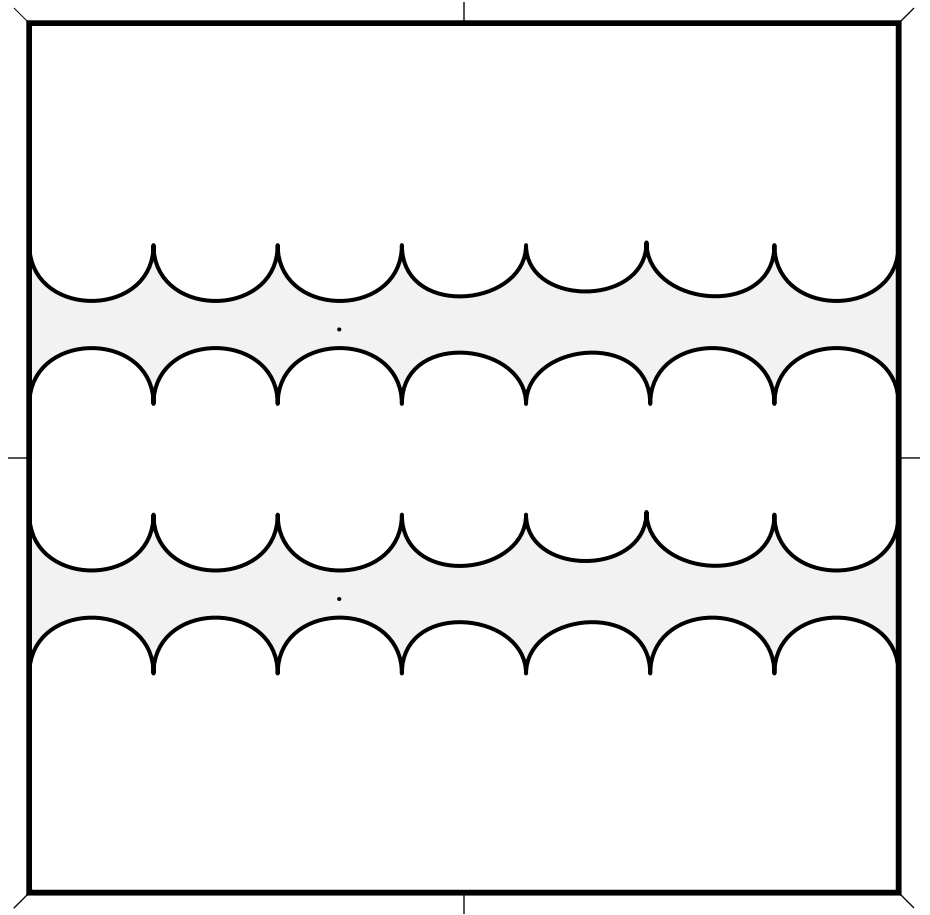
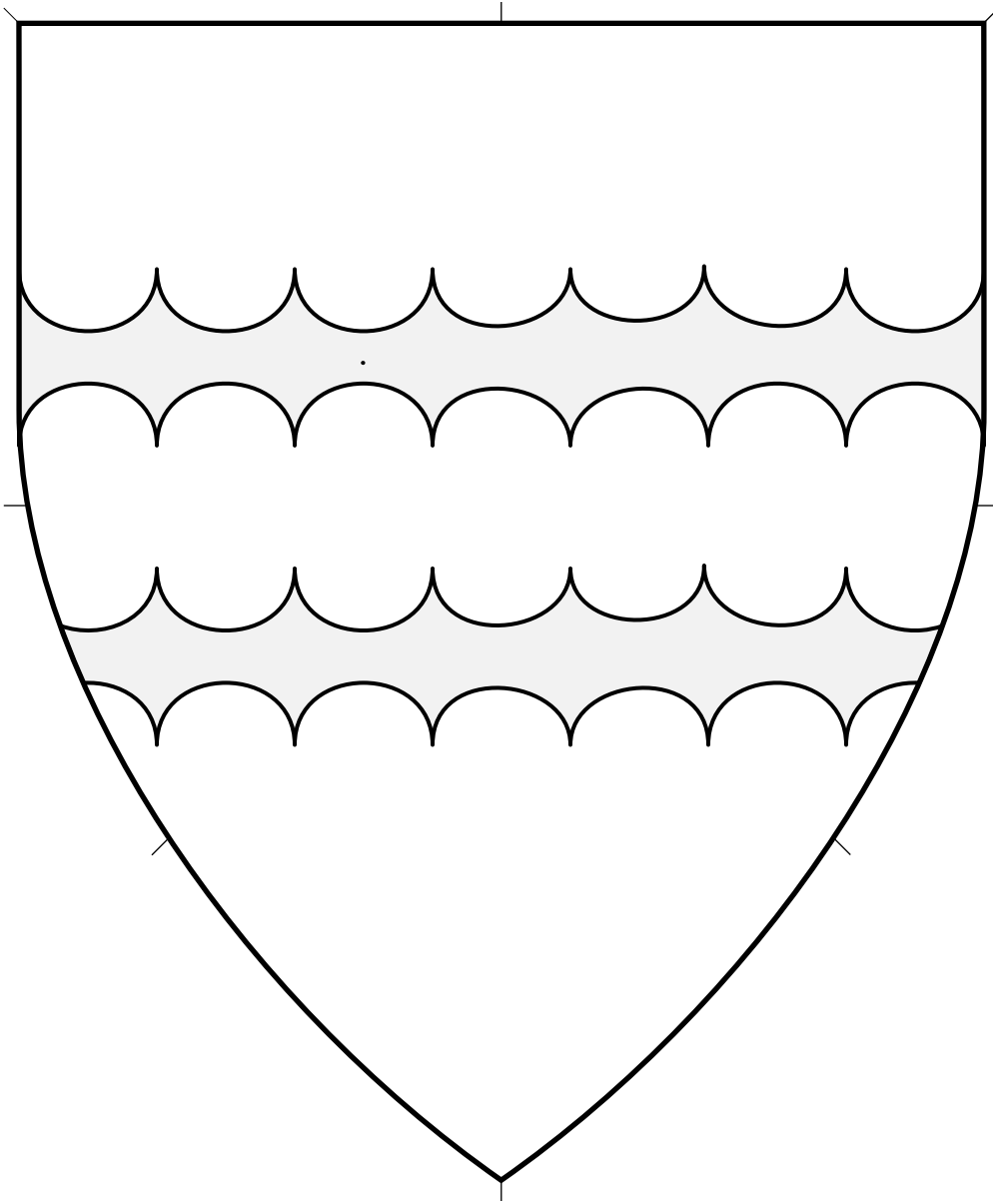

Central ordinary.

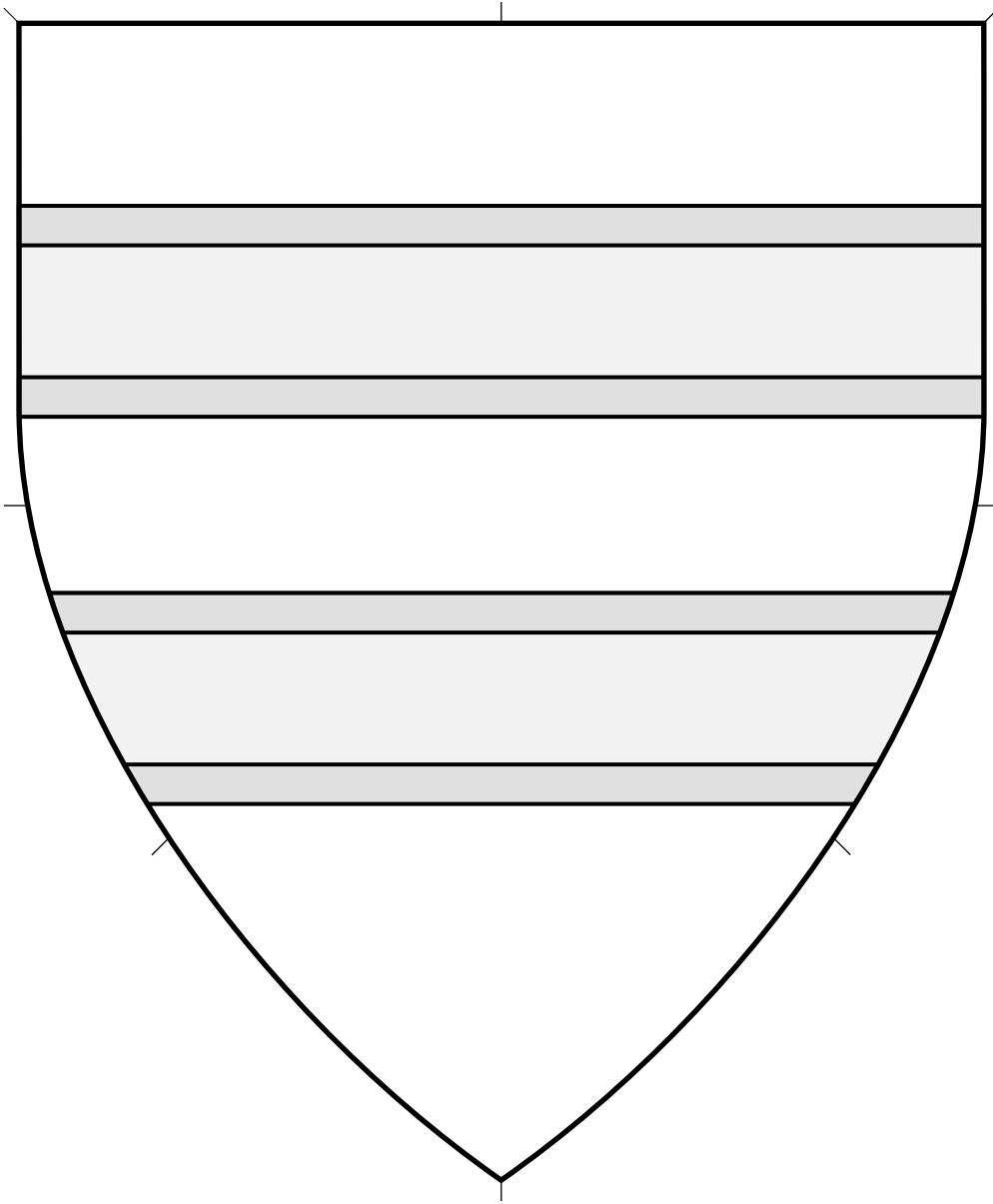

Central ordinary.

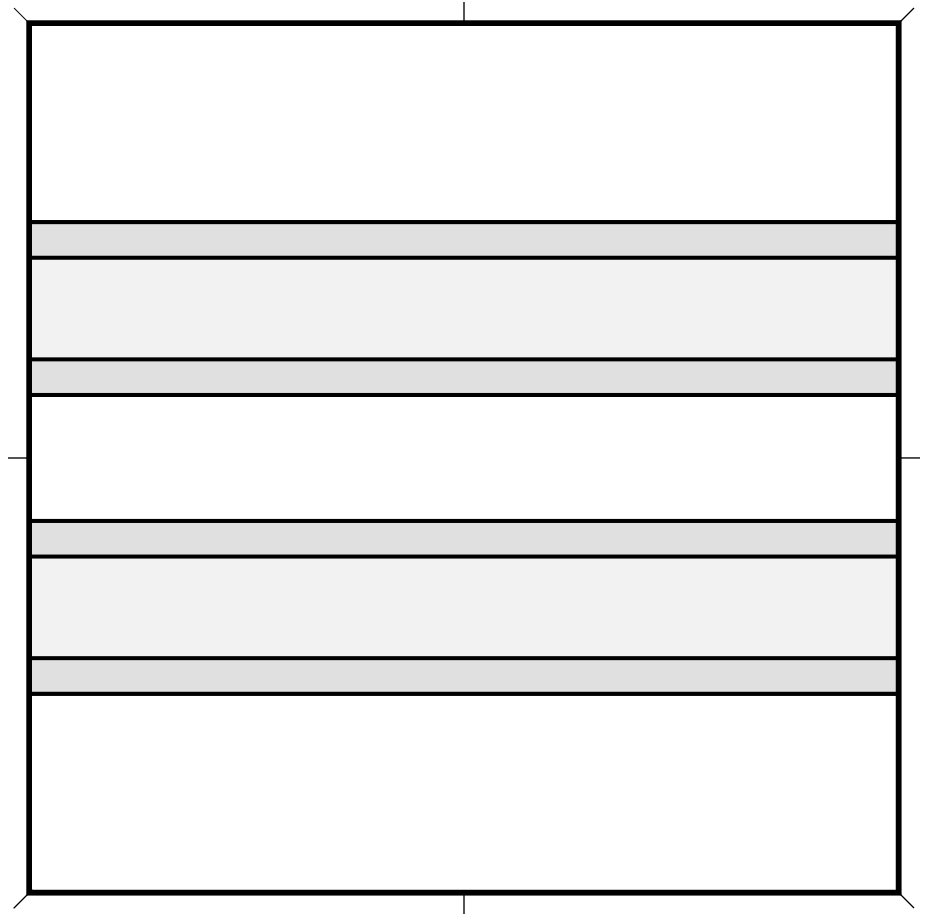

Bars Fimbriated, Two 4.15

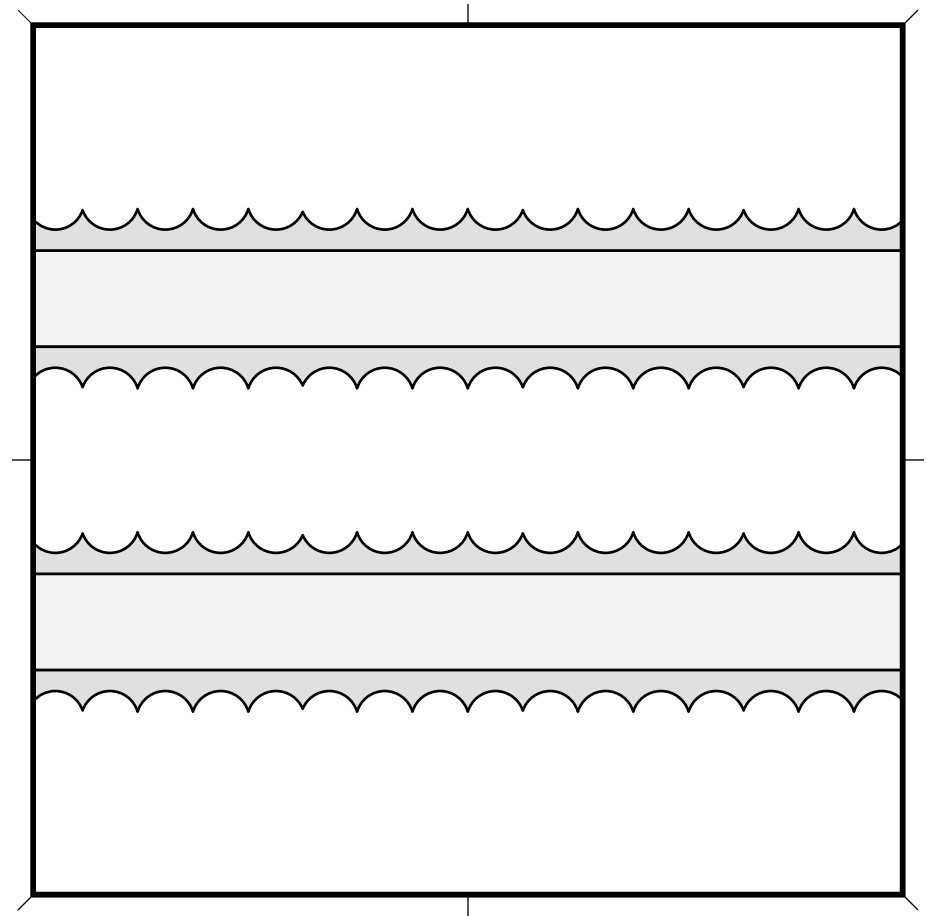
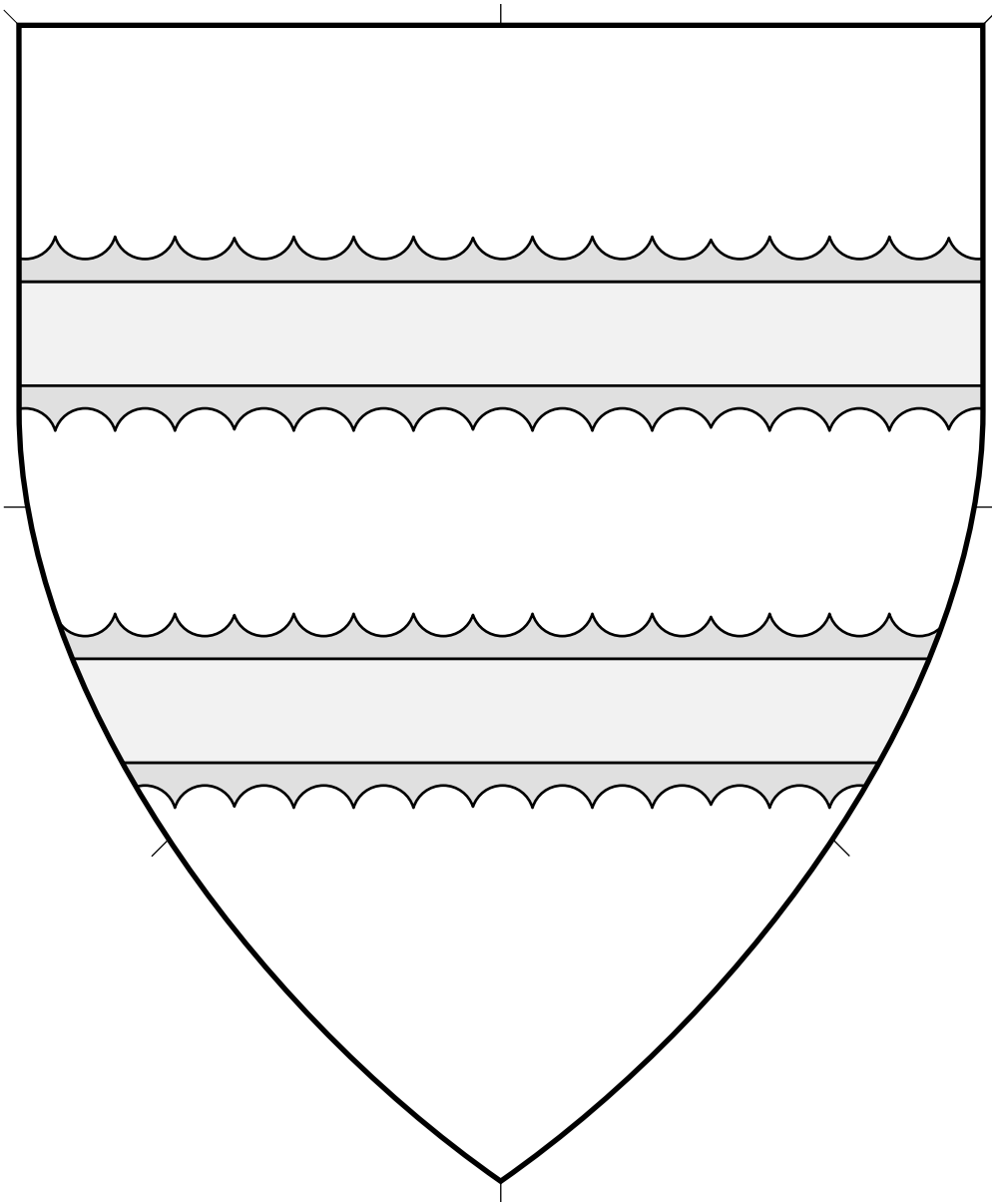

Central ordinary.

Source: Armorial Lorrain de la Première Moitié du XVIe Siècle. (Page 150.) Artist unknown.

Bars Fimbriated Engrailed, Two 4.16

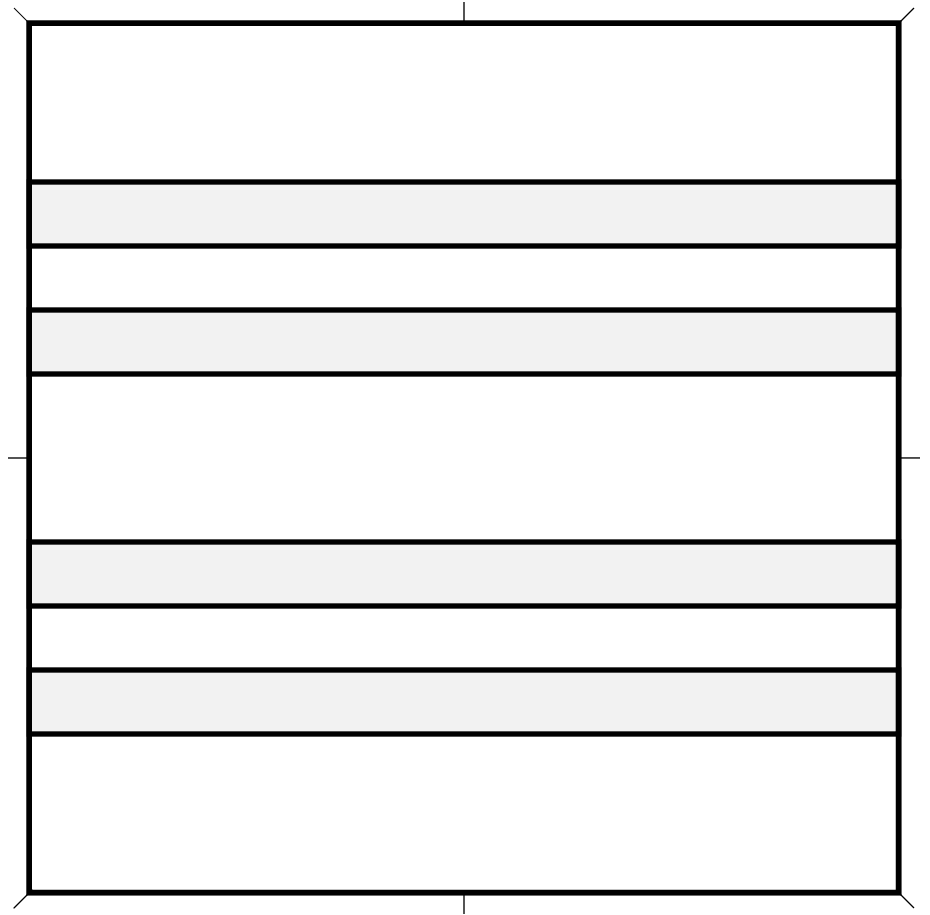
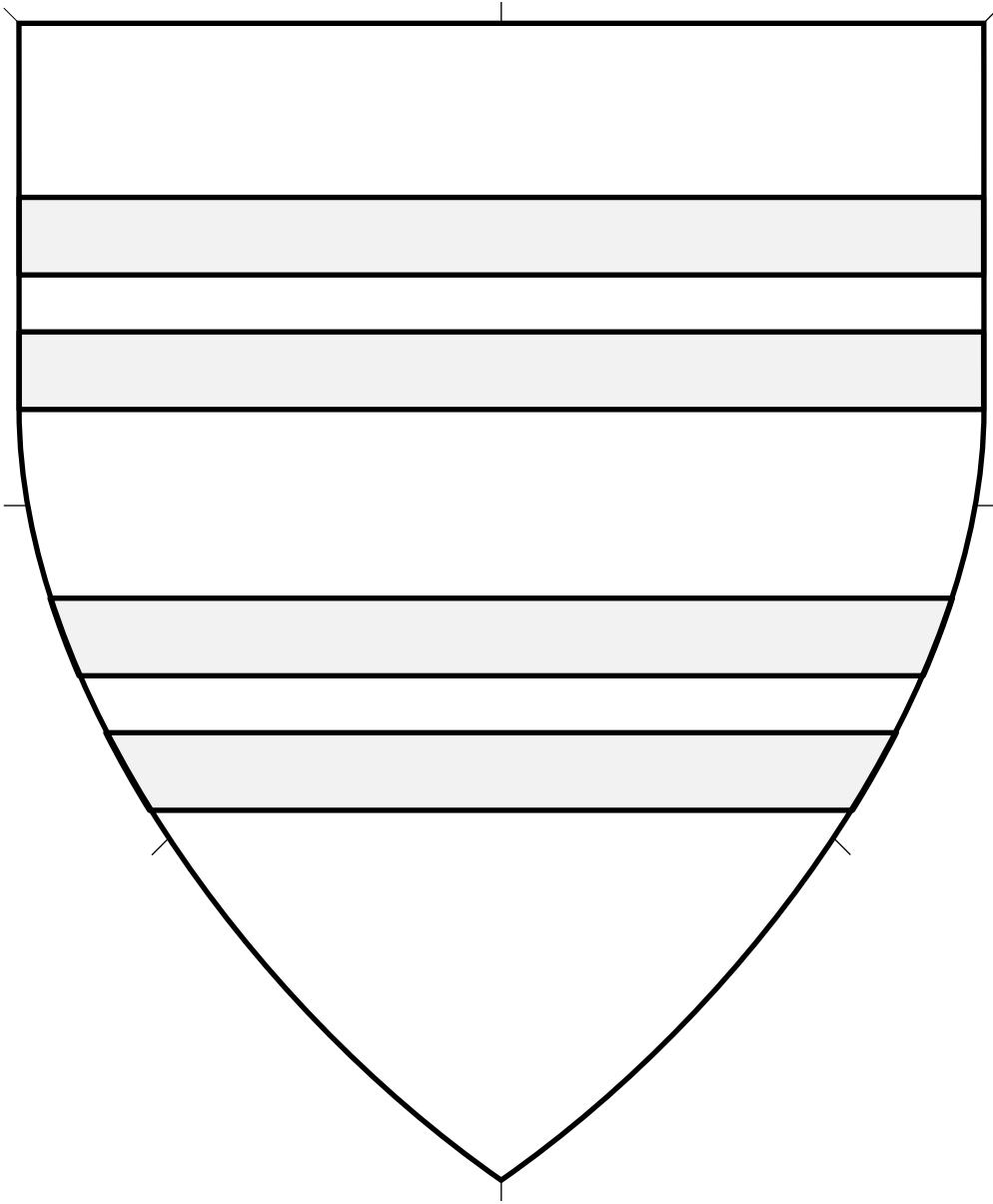

Central ordinary. A fess voided.

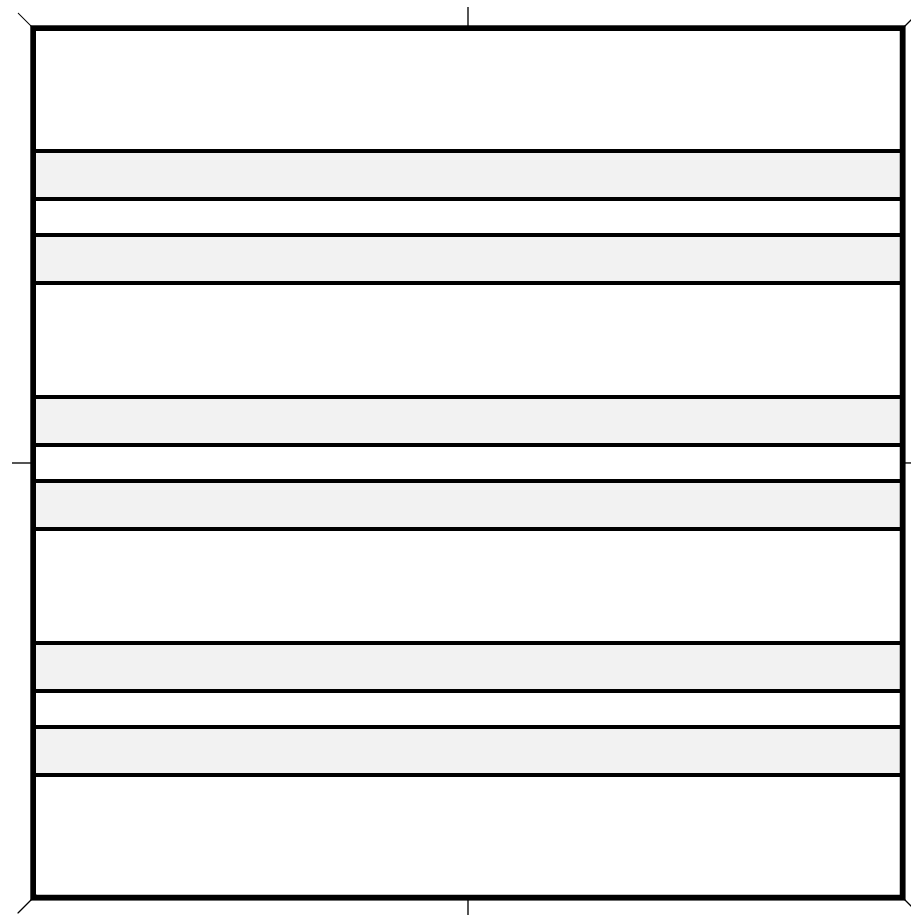
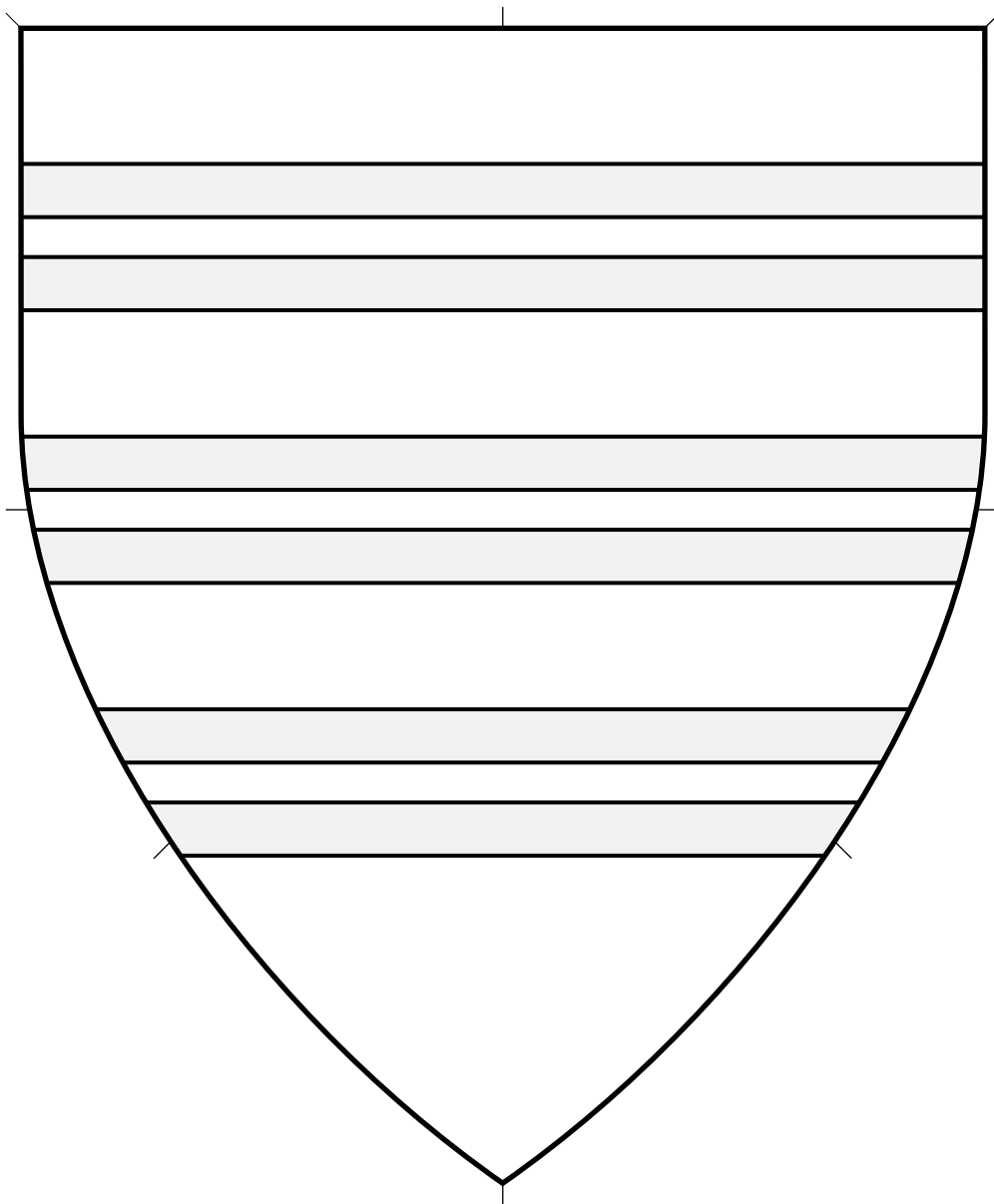

Central ordinary.

Source: Wapenboek van Gent. Artist: Vander Schelden.
(Volume 1, page 31.)

Bars Gemel, 3 4.18

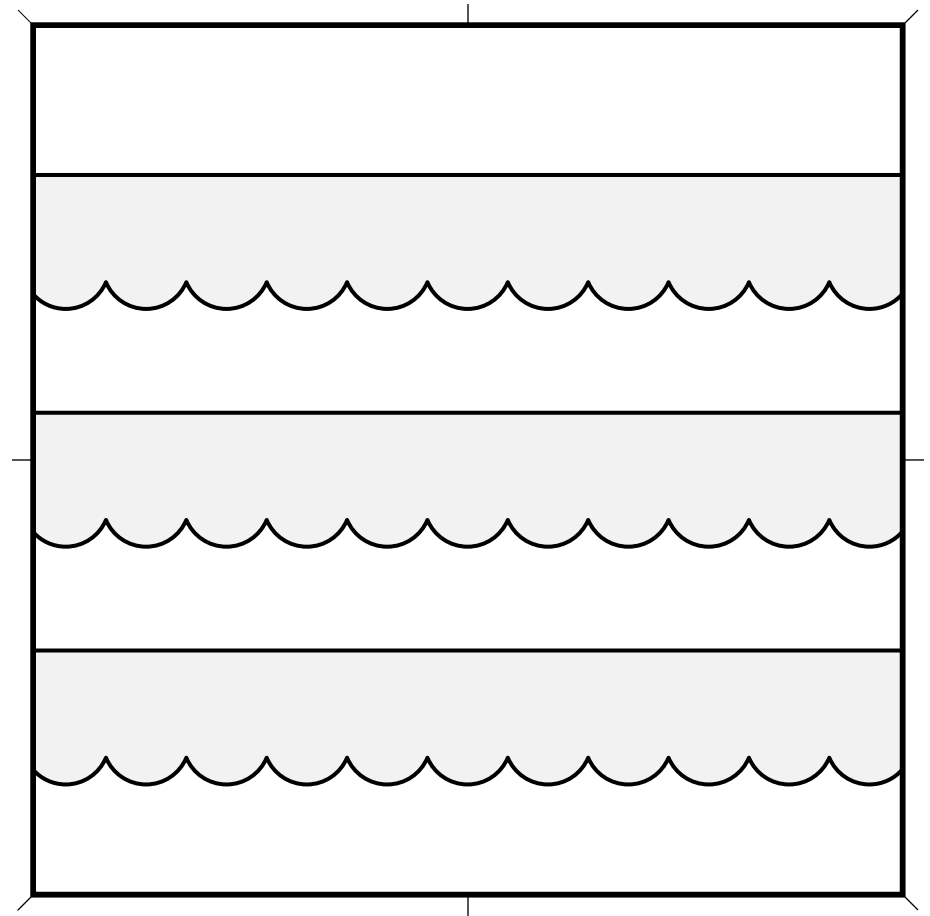
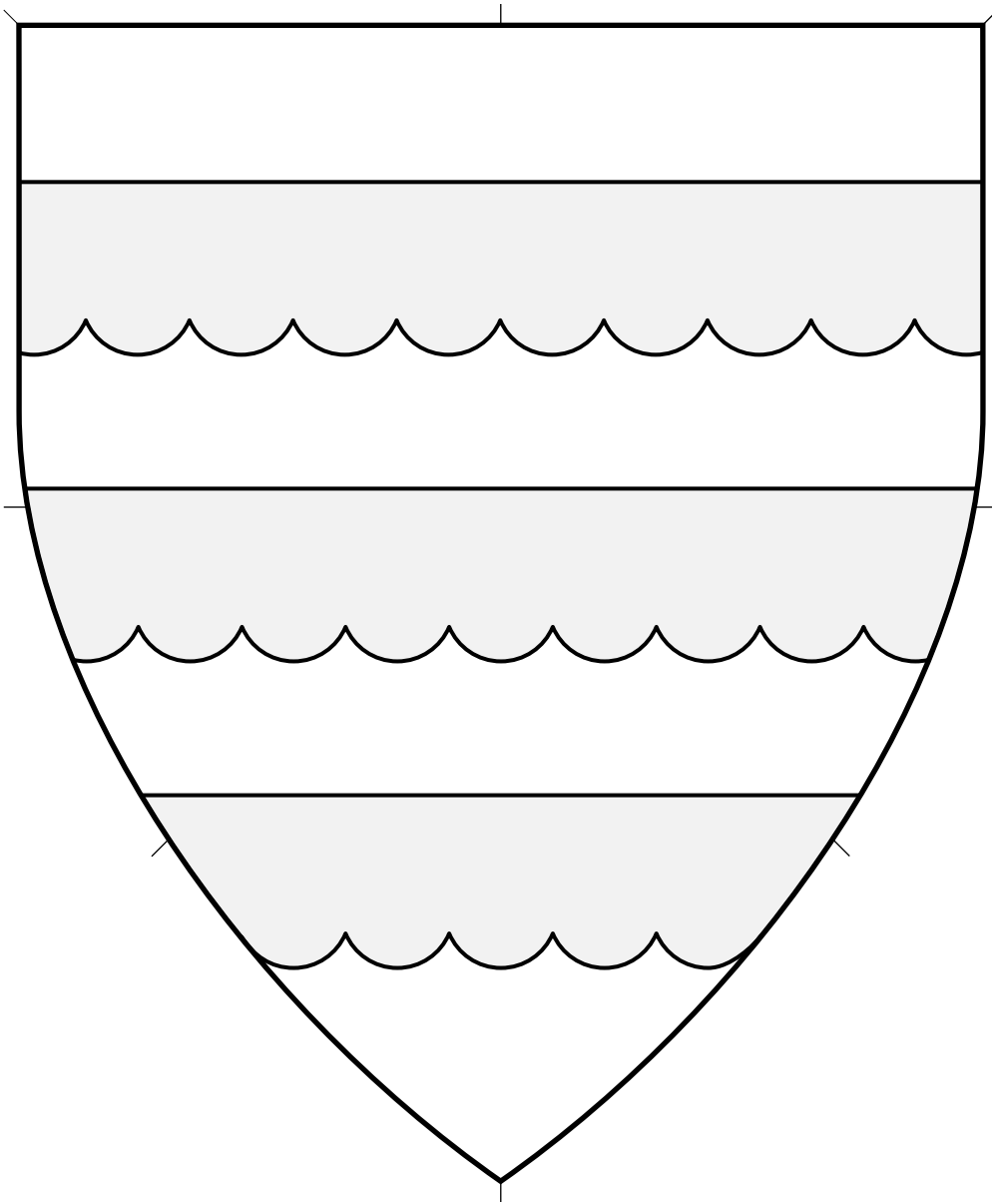

Central ordinary.

Source: Insignia Equitum Gallici Ordinis Sancti Michaelis. Artist unknown. (Page 177.)

Bars Invested on the Lower Edge, Three 4.19

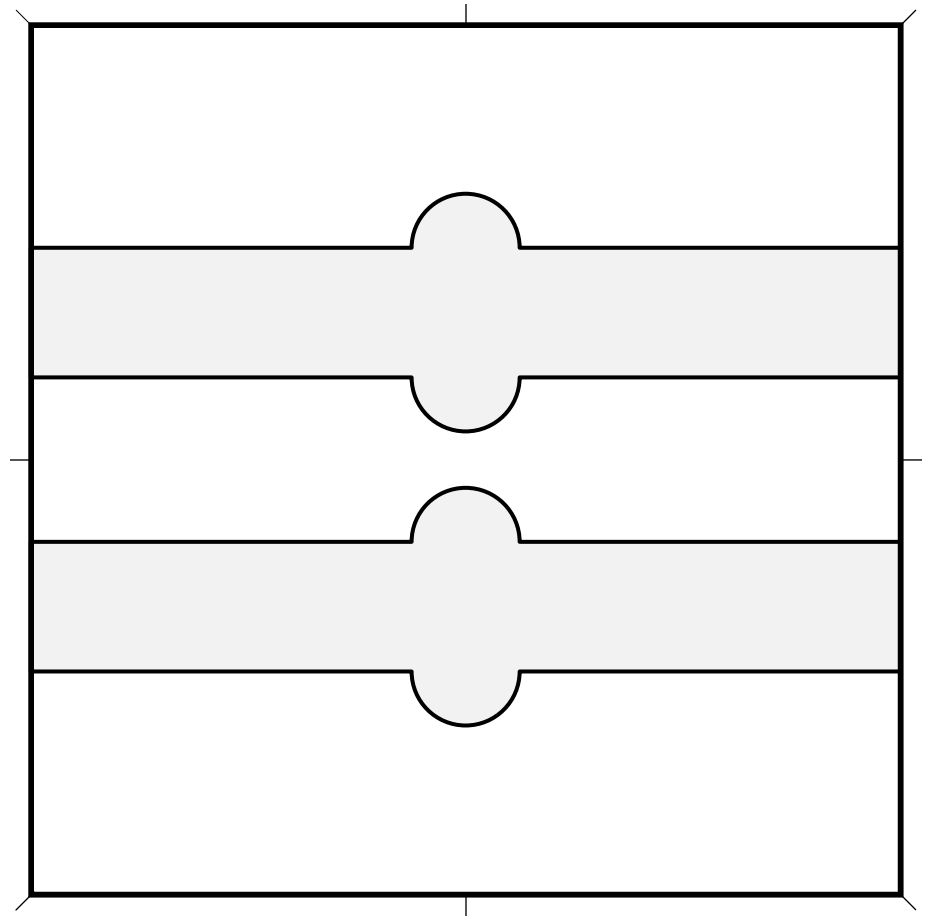
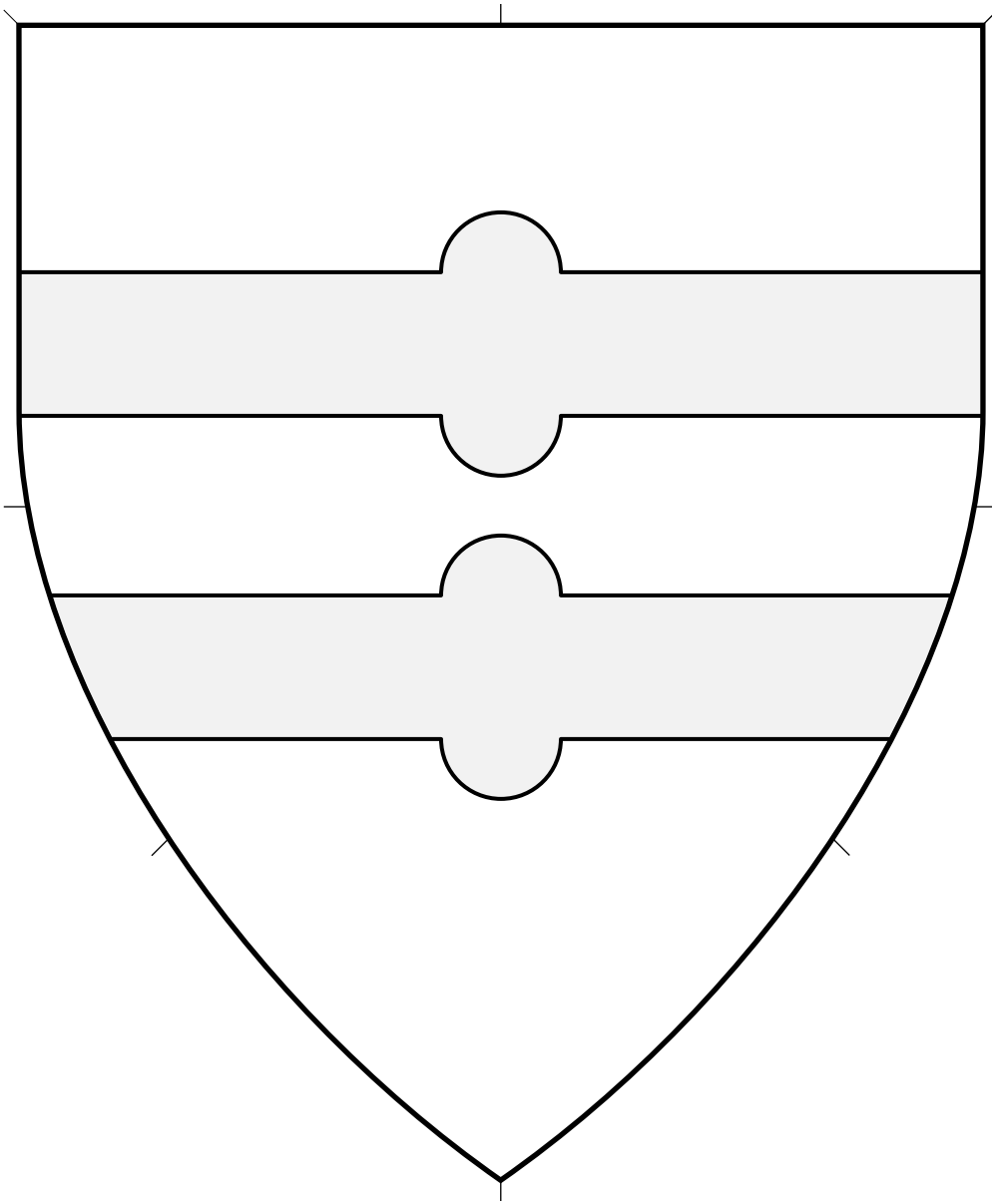

Central ordinary.

Source: Armorial of the Herald of Navarra. (Folio 46v.) Artist unknown.

Bars Nowy, Two 4.20

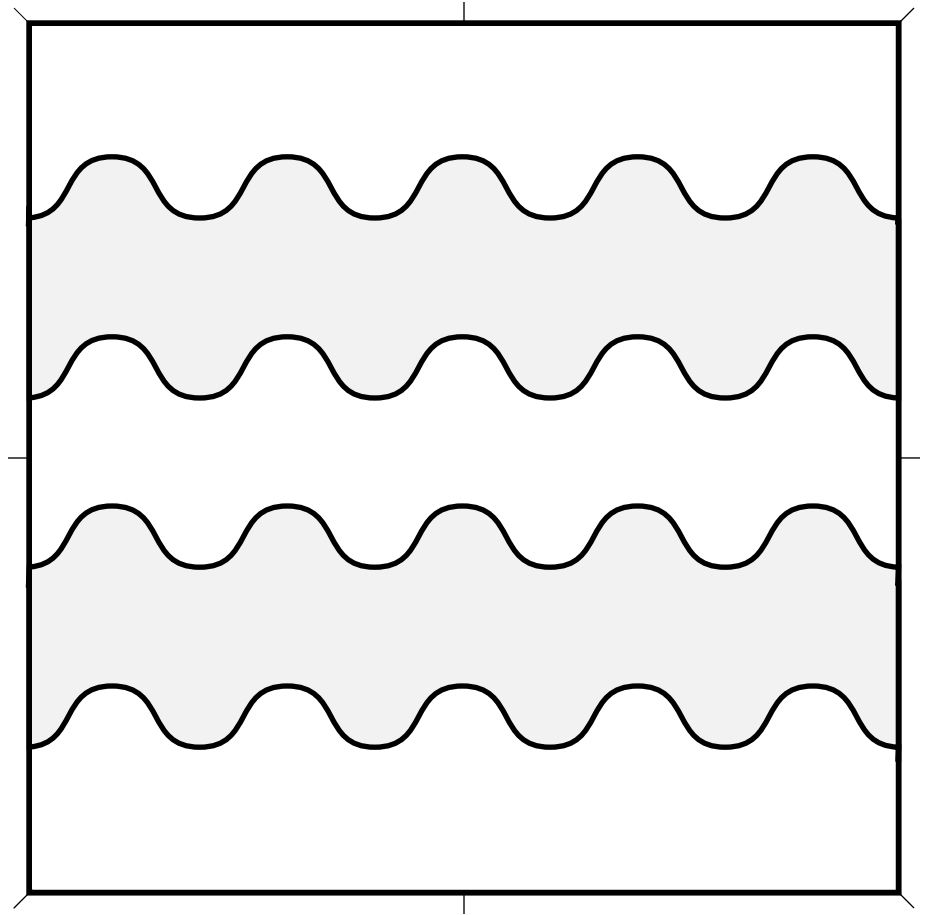
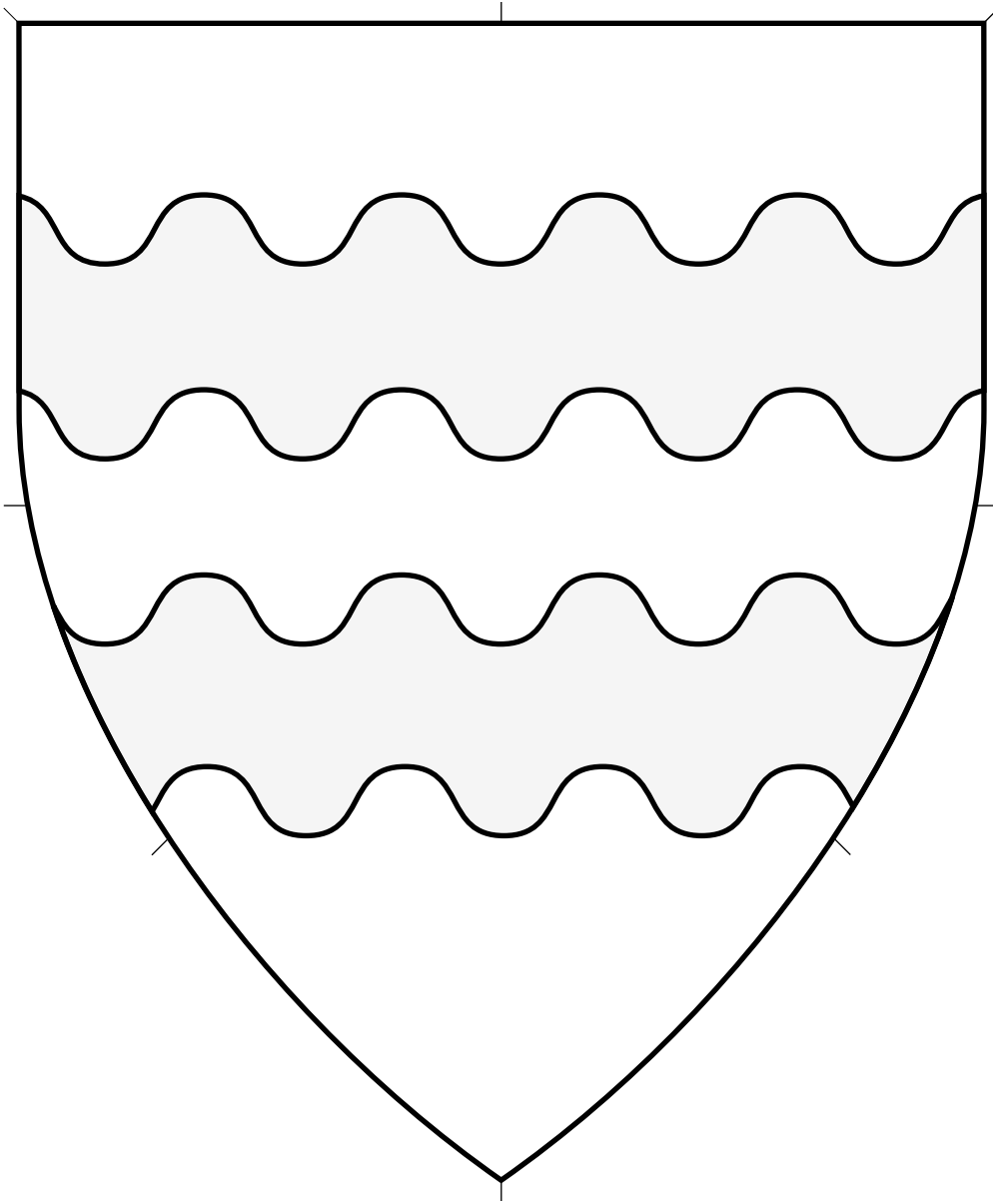

Central ordinary.

Bars Wavy, Two (1) 4.21

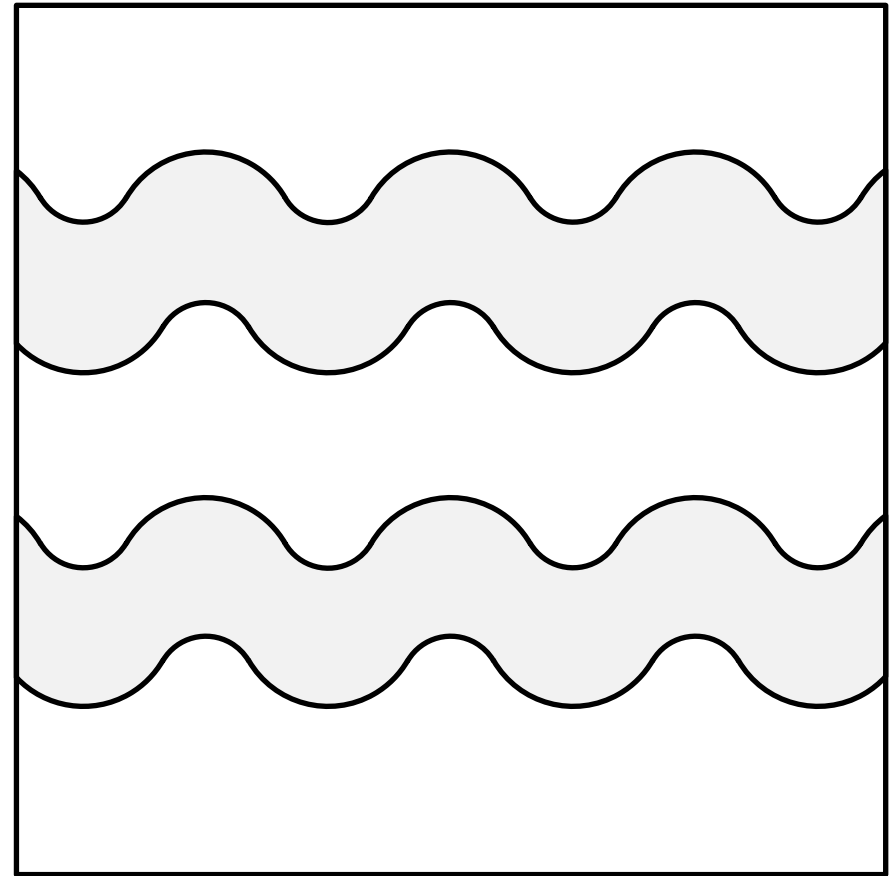
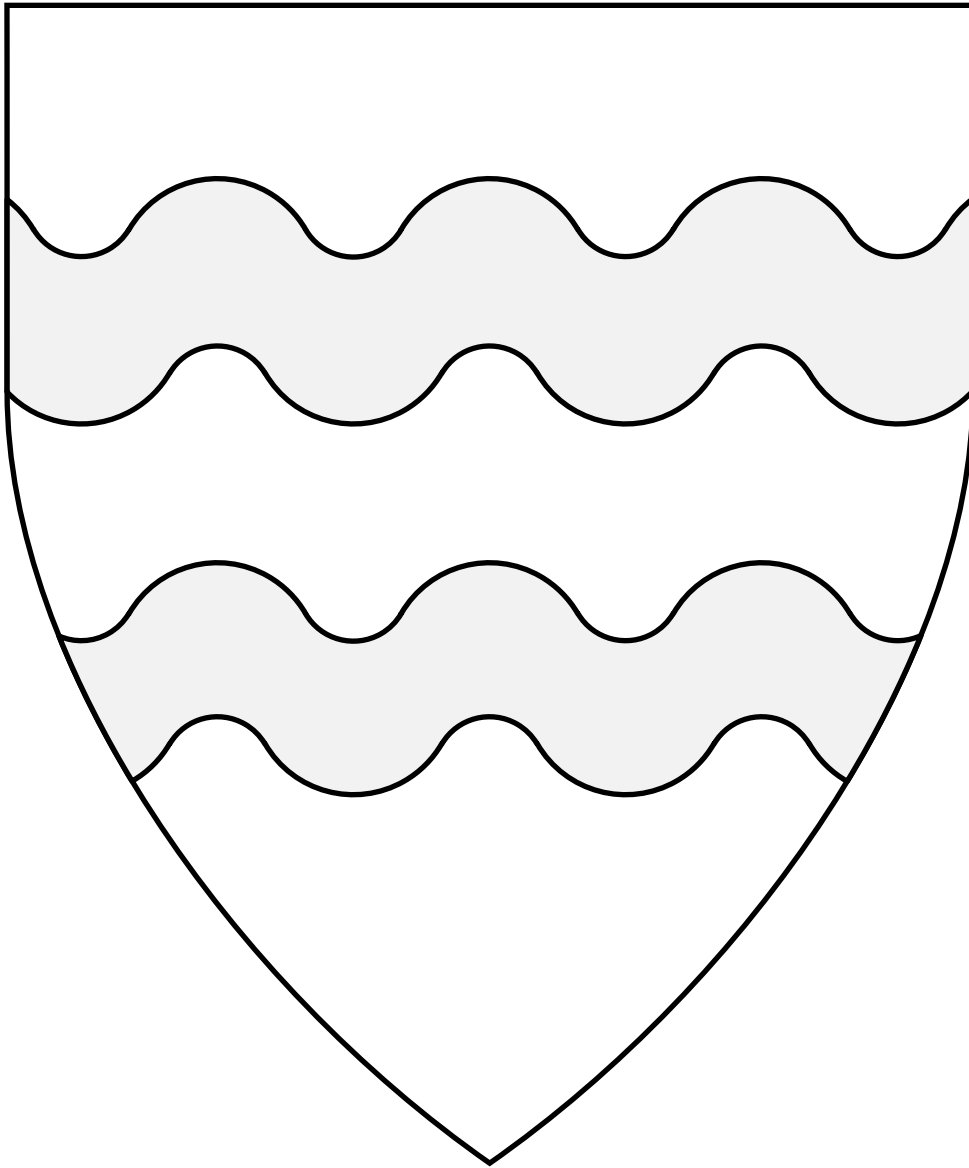

Central ordinary.
Source: Crawford's Armorial. (Arms of Drummond.) Artist unknown.
(Painted in Scotland around 1601.)
Adapted by Mathghamhain Ua Ruadháin.

Bars Wavy, Two (2) 4.22

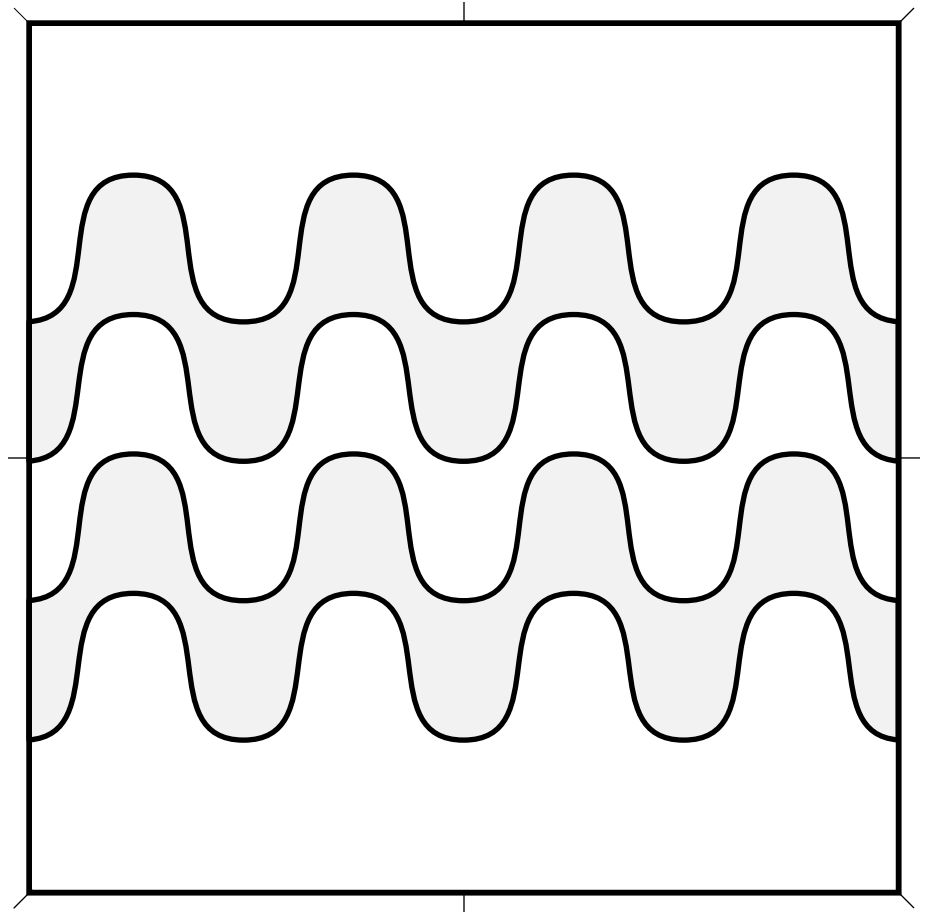
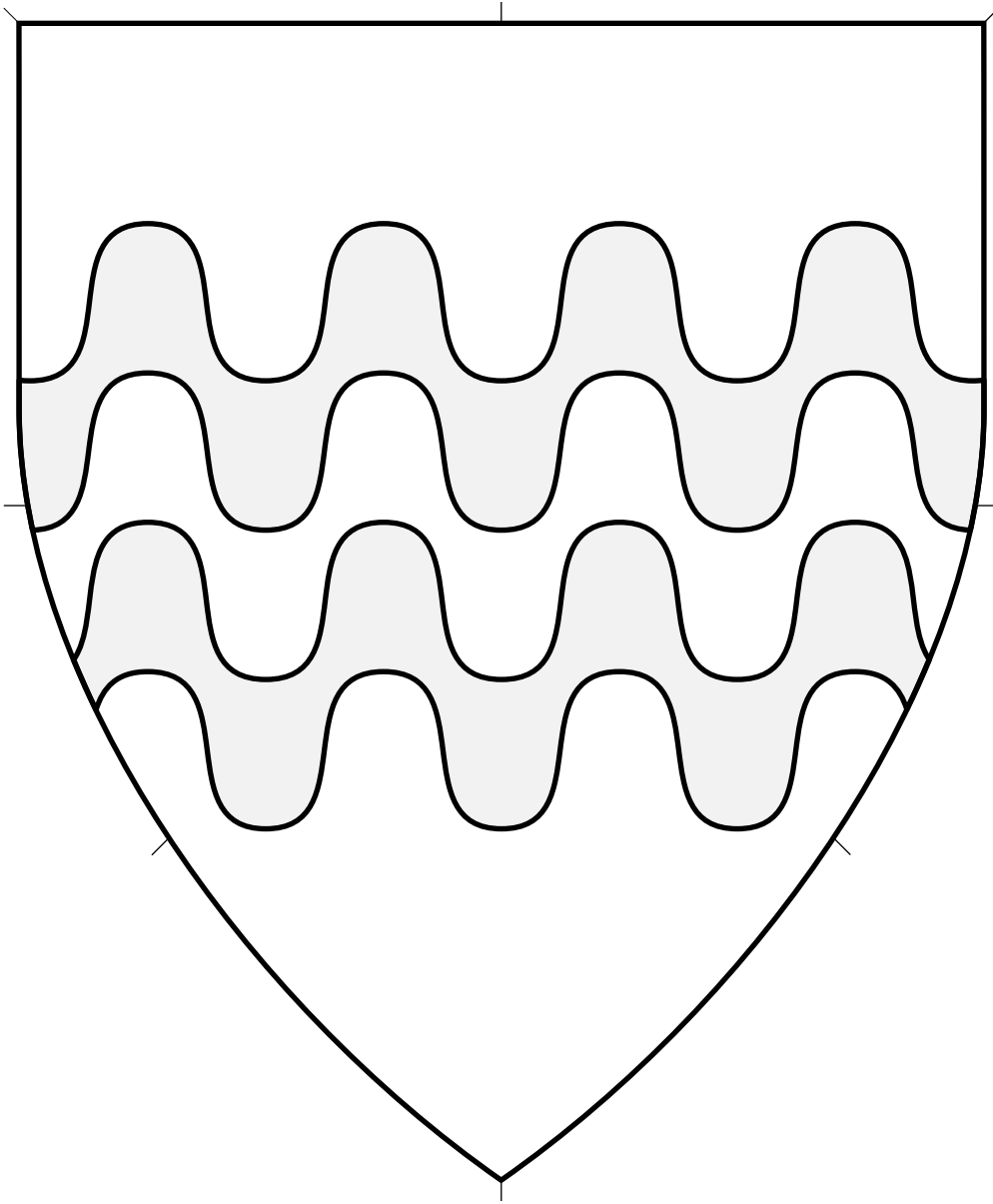

Central ordinary.

Bars Wavy, Two (3) 4.23

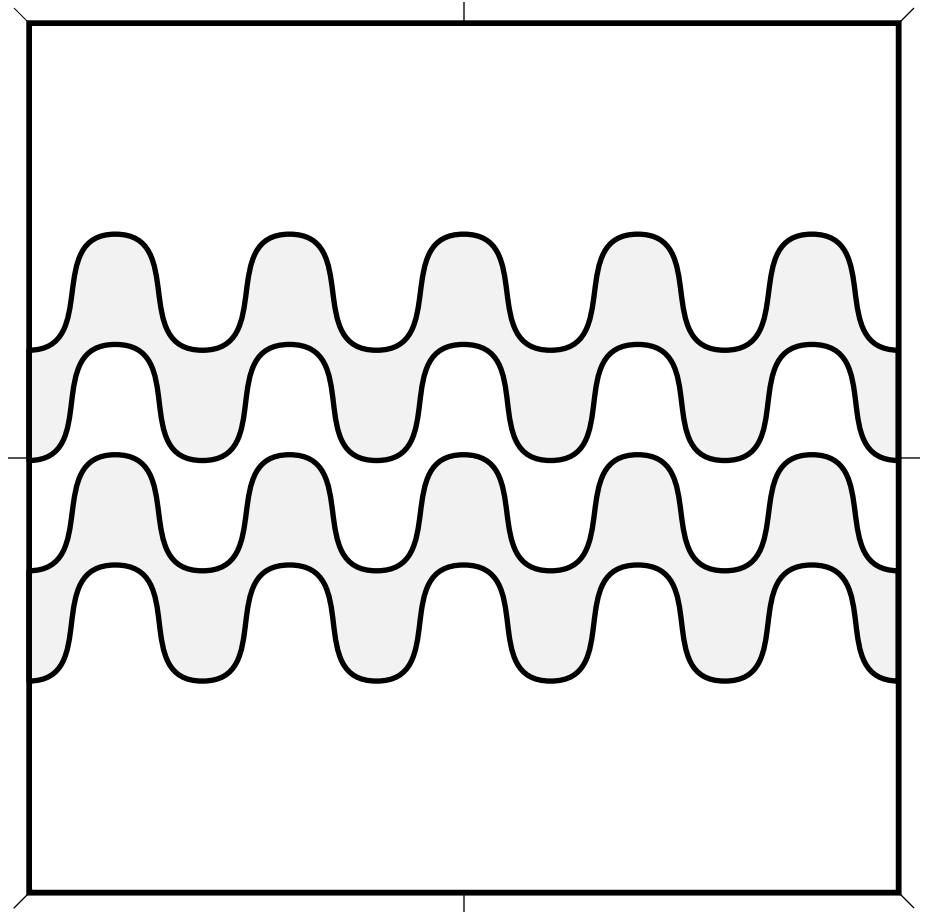
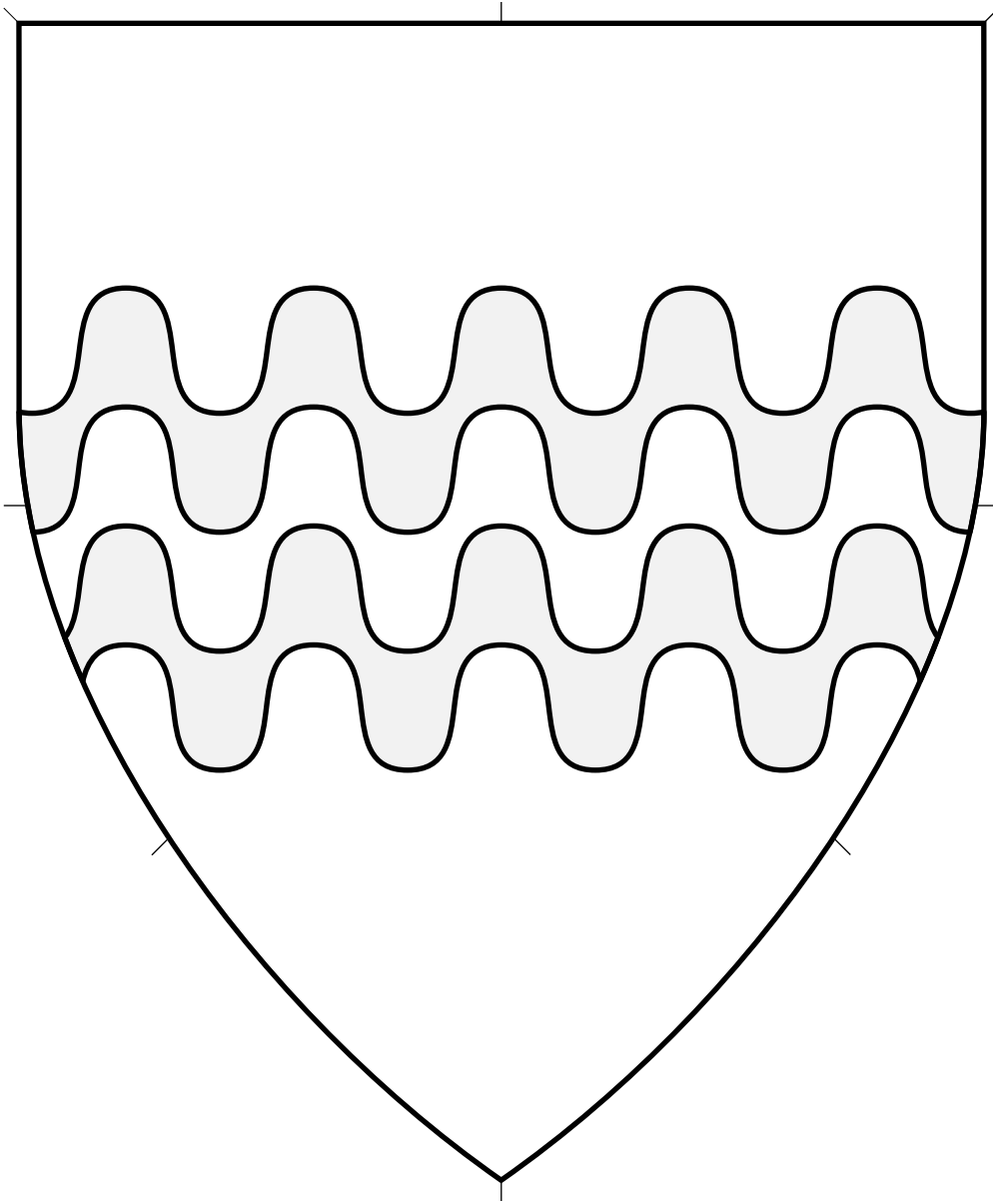

Central ordinary.

Bars Wavy, Two (4) 4.24

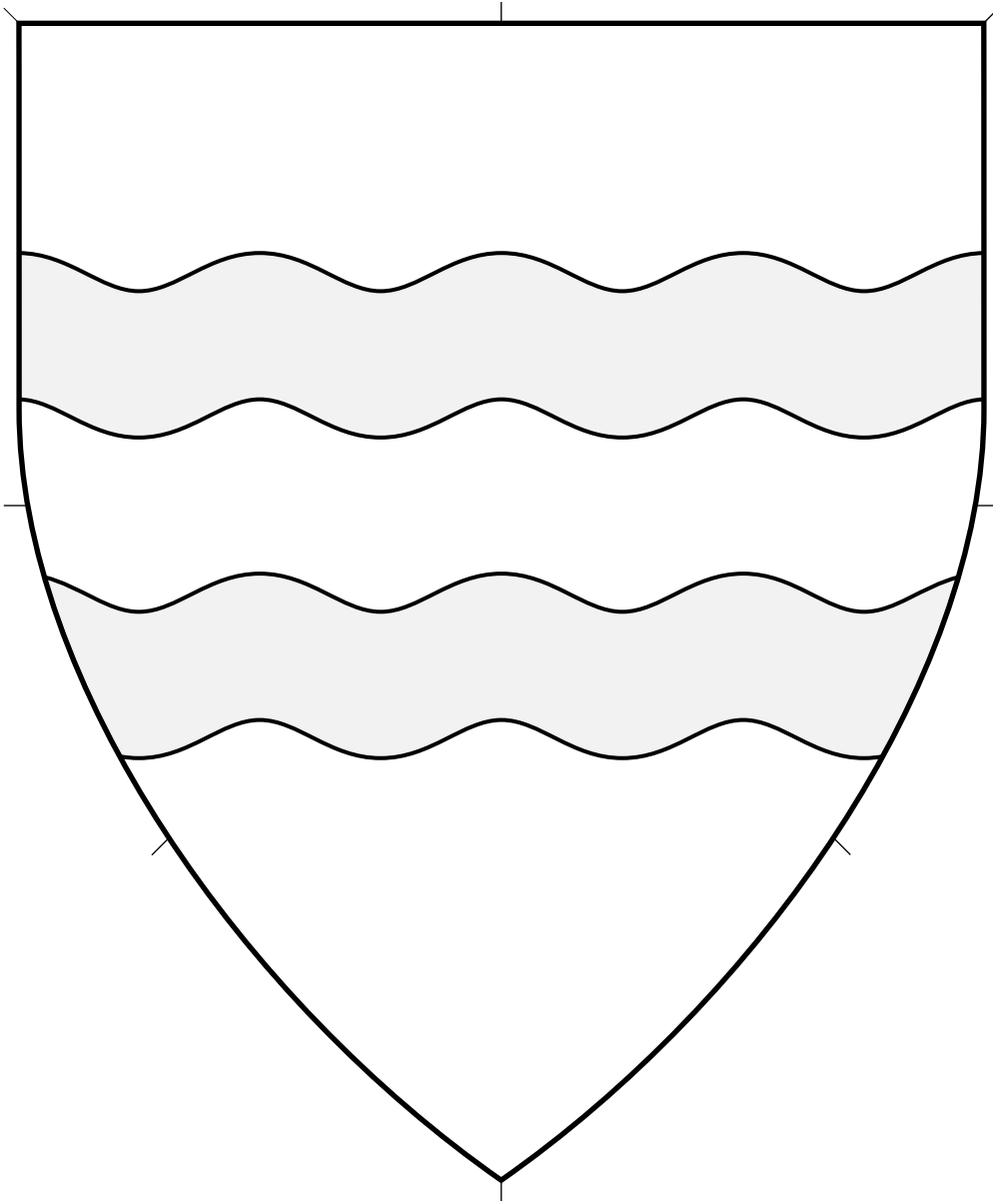

Central ordinary.

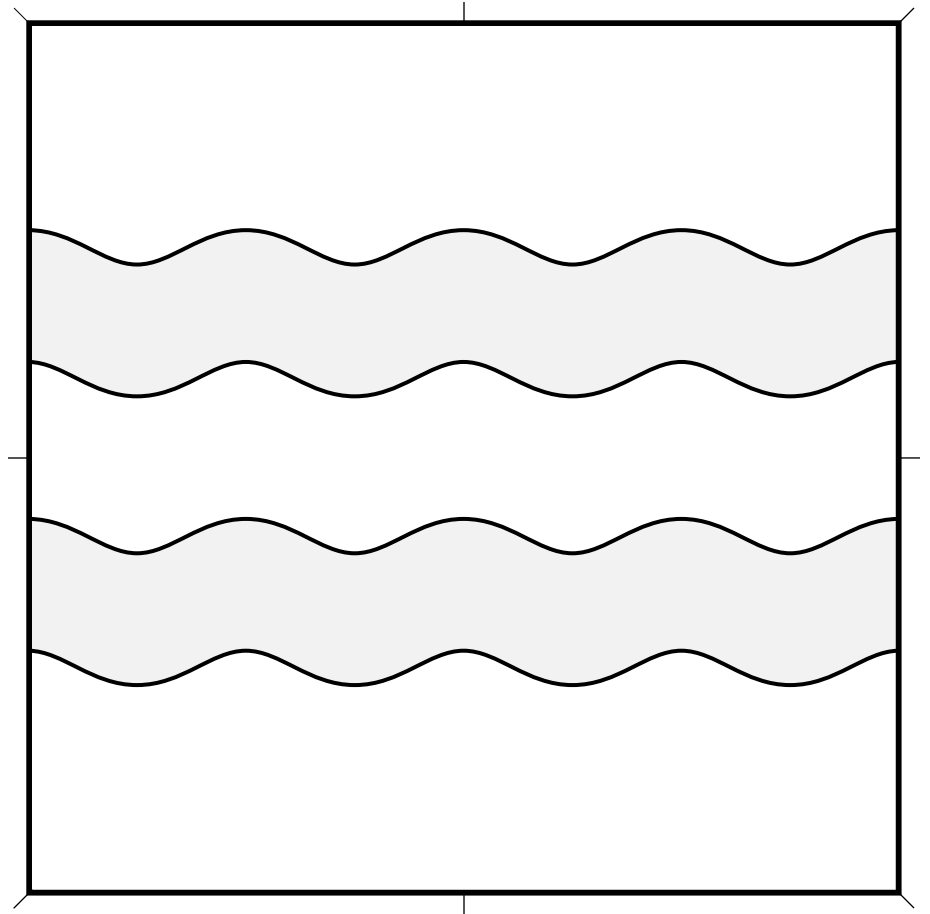

Bars Wavy, Two (5) 4.25

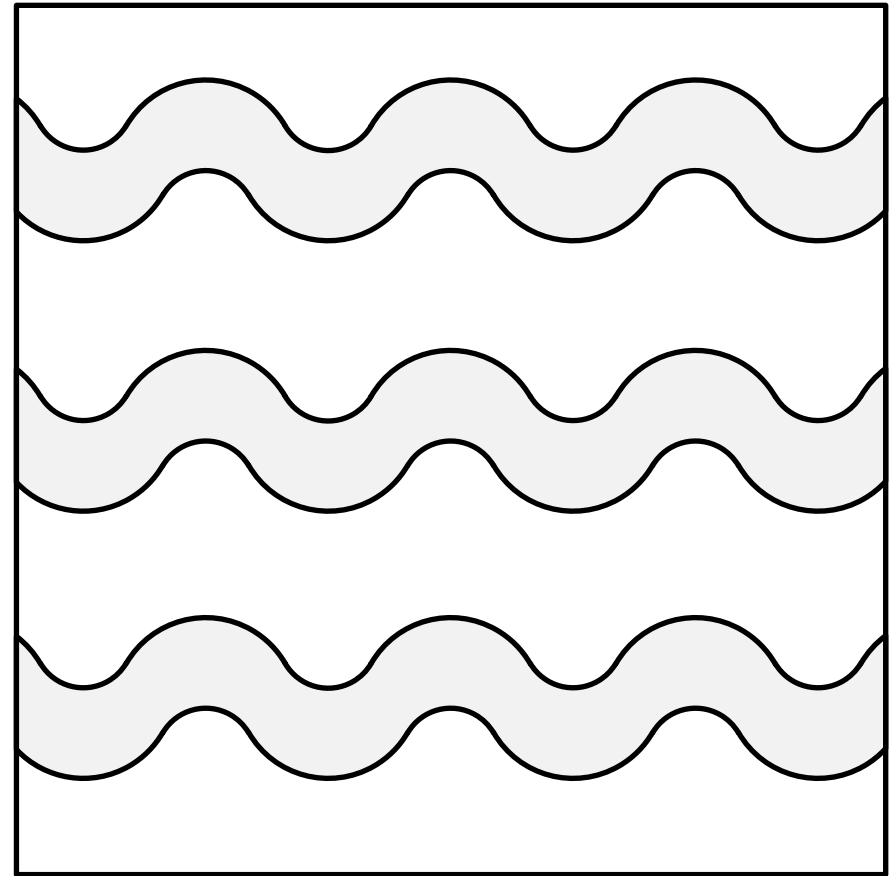
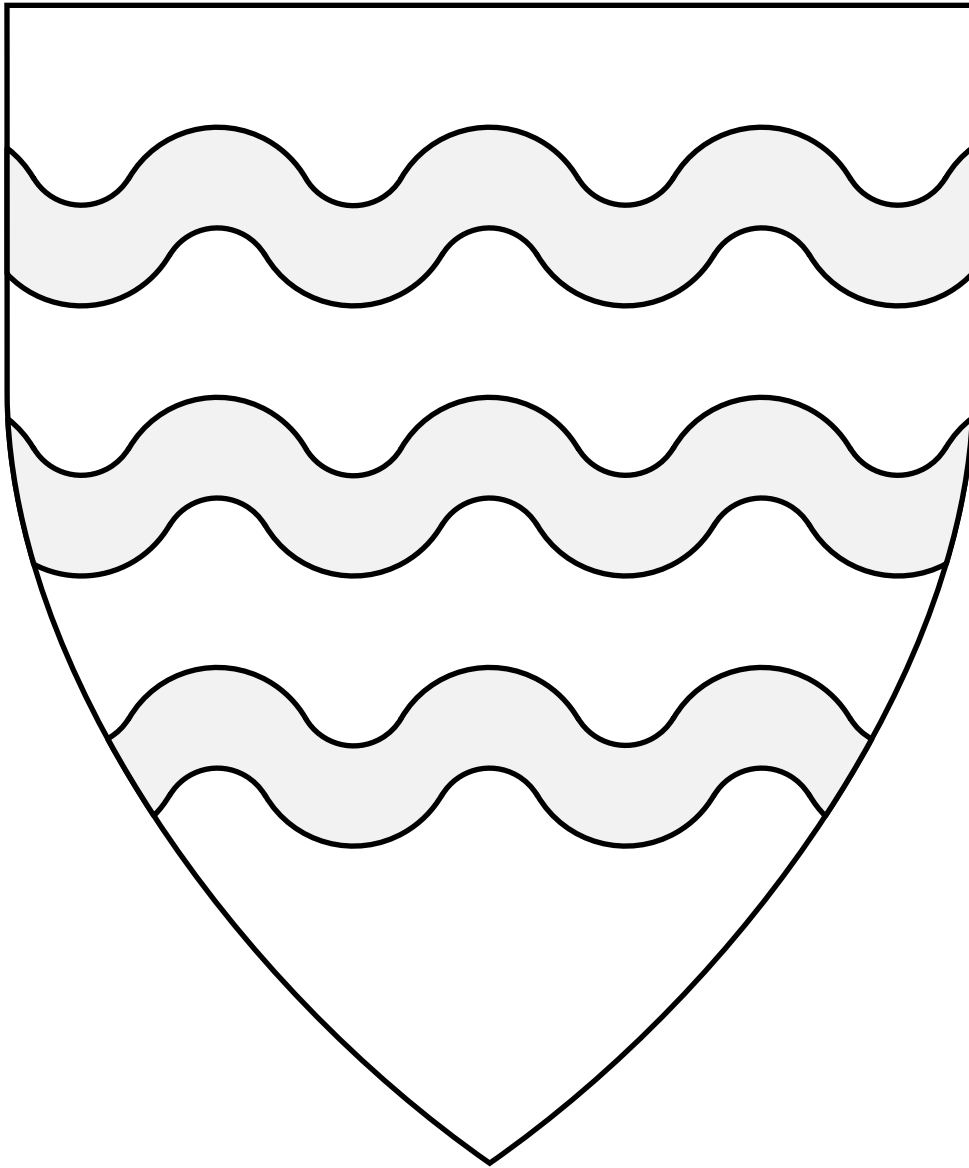

Central ordinary.
Source: Crawford's Armorial. (Arms of Drummond.) Artist unknown.
(Painted in Scotland around 1601.)

Bars Wavy, Three (1) 4.26

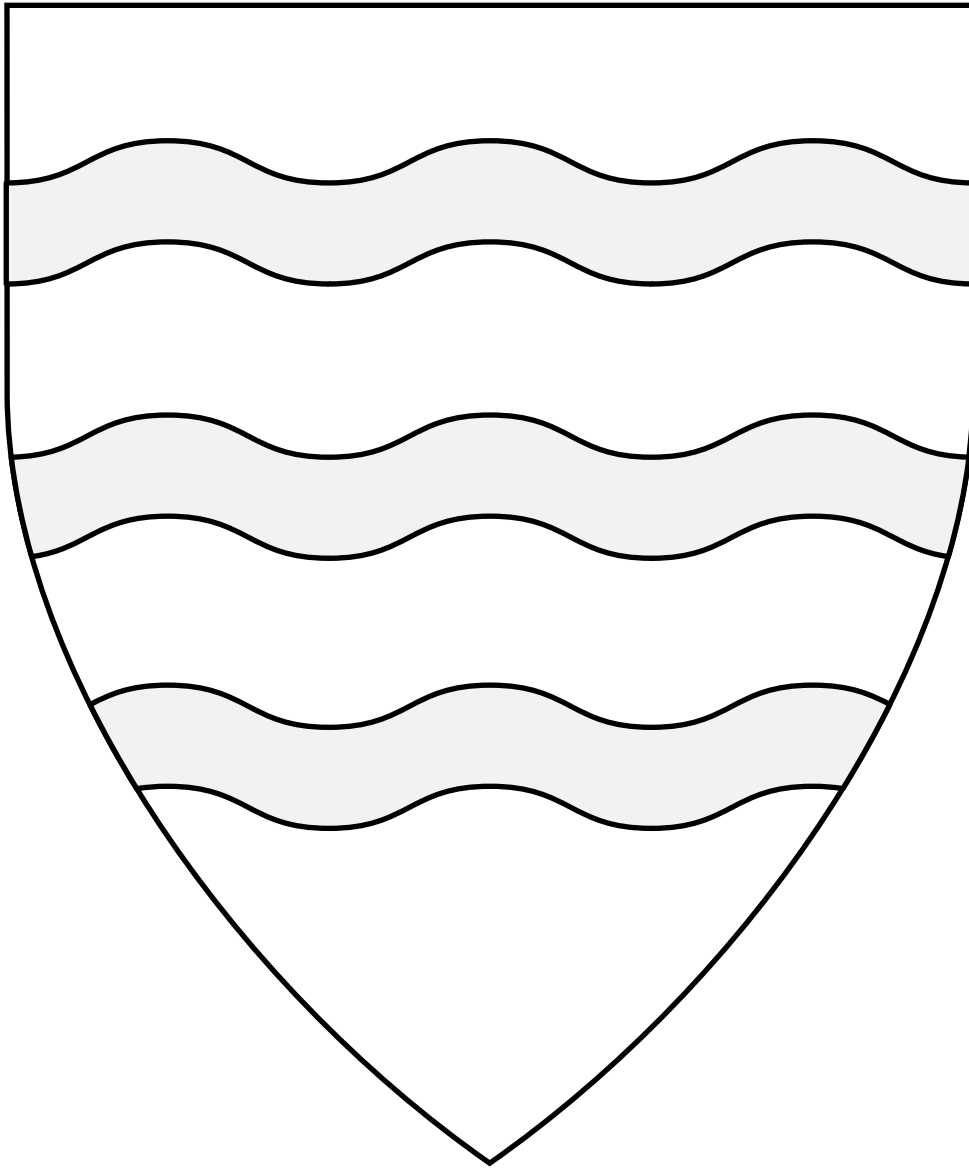

Central ordinary.

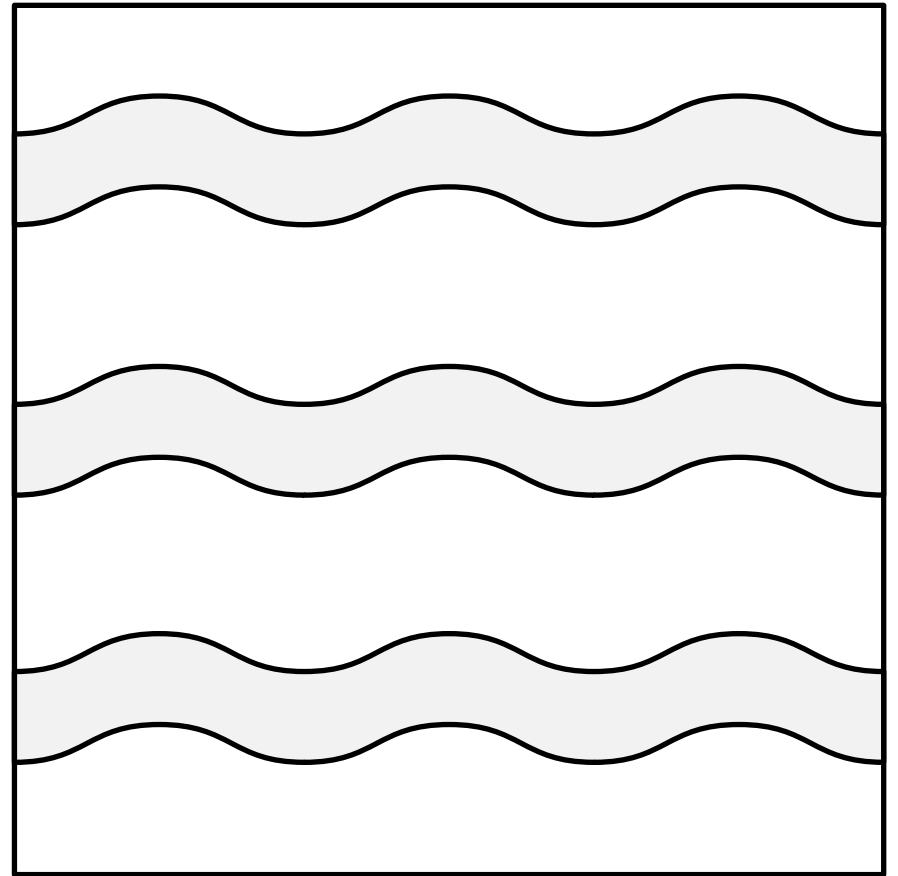

Bars Wavy, Three (2) 4.27

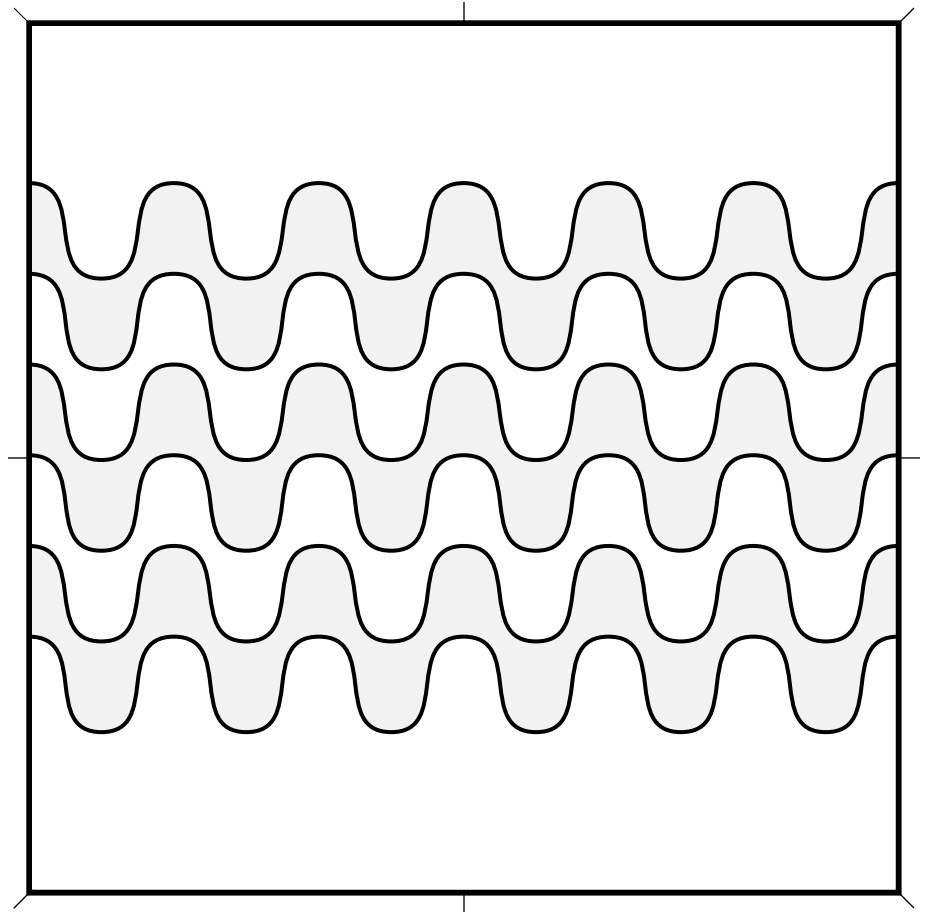
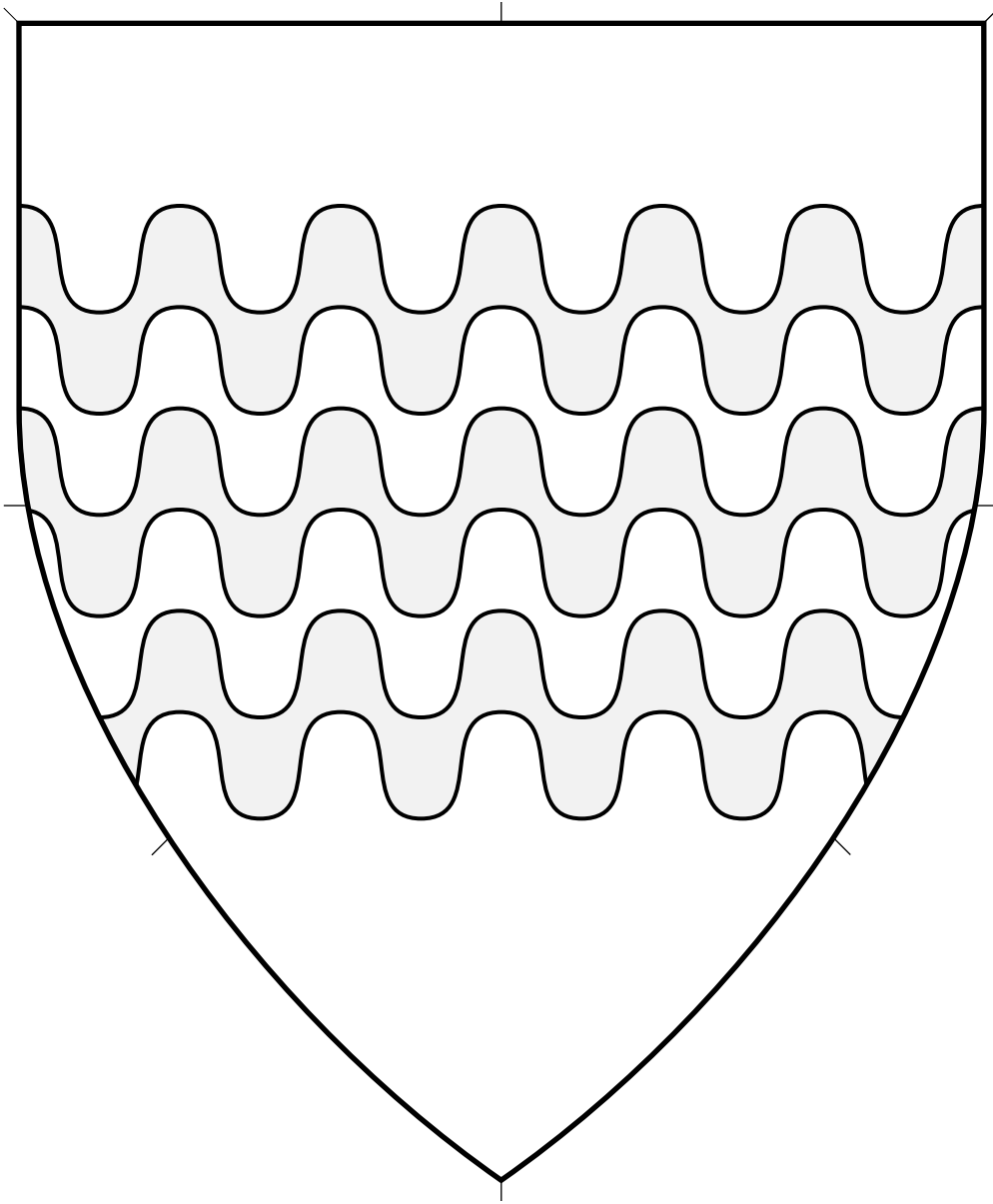

Central ordinary.

Bars Wavy, Three (3) 4.28

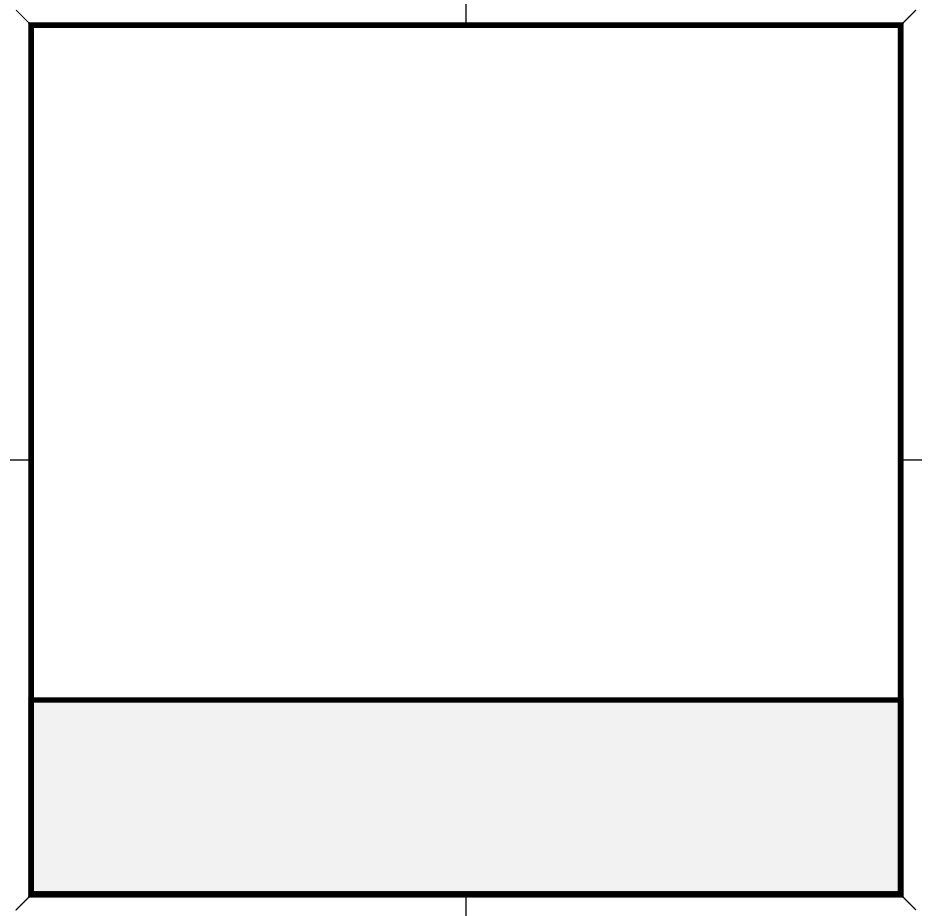
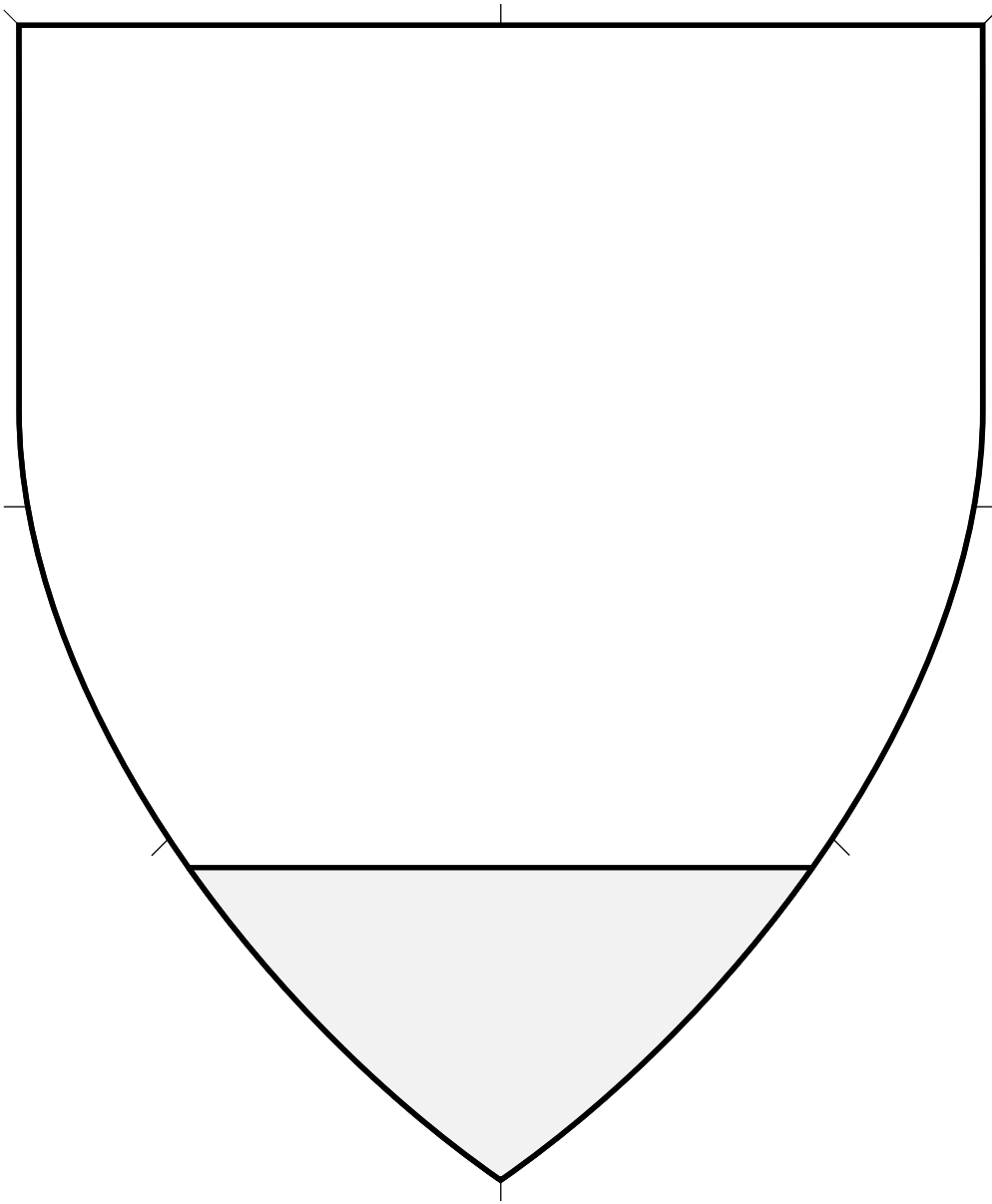

Peripheral ordinary. The height is typically a third of the width of the device.

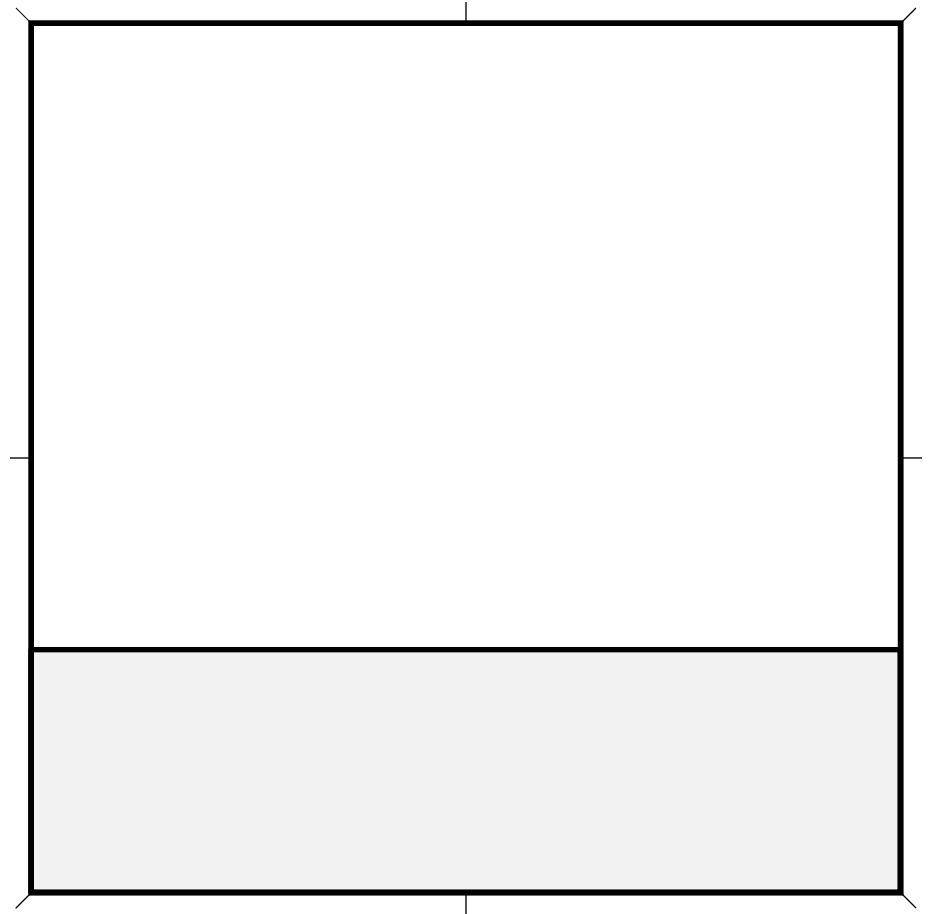
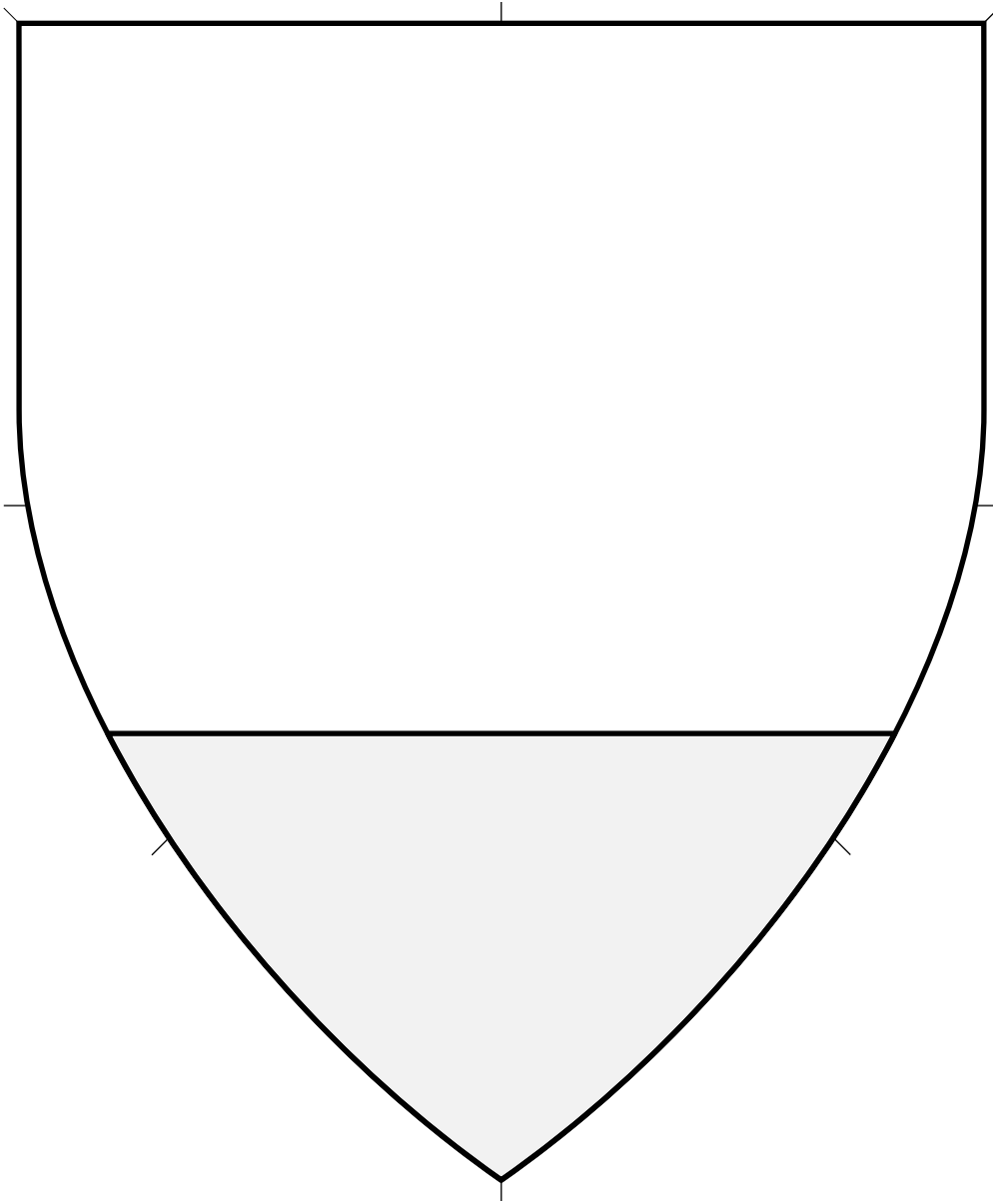

Peripheral ordinary.

Source: Viking Answer Lady SVG Images For Heraldry.
Artist: Gunnvôr silfrahárr. Adapted by Mathghamhain Ua Ruadháin.

Base (2) 4.30

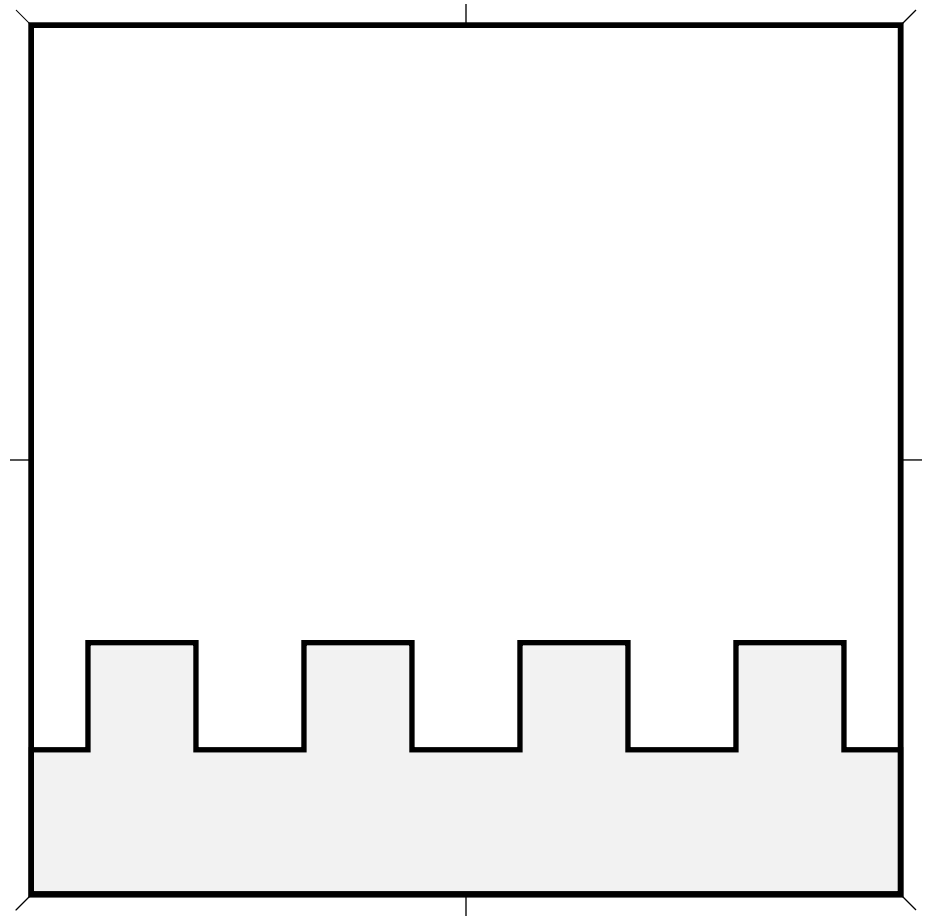
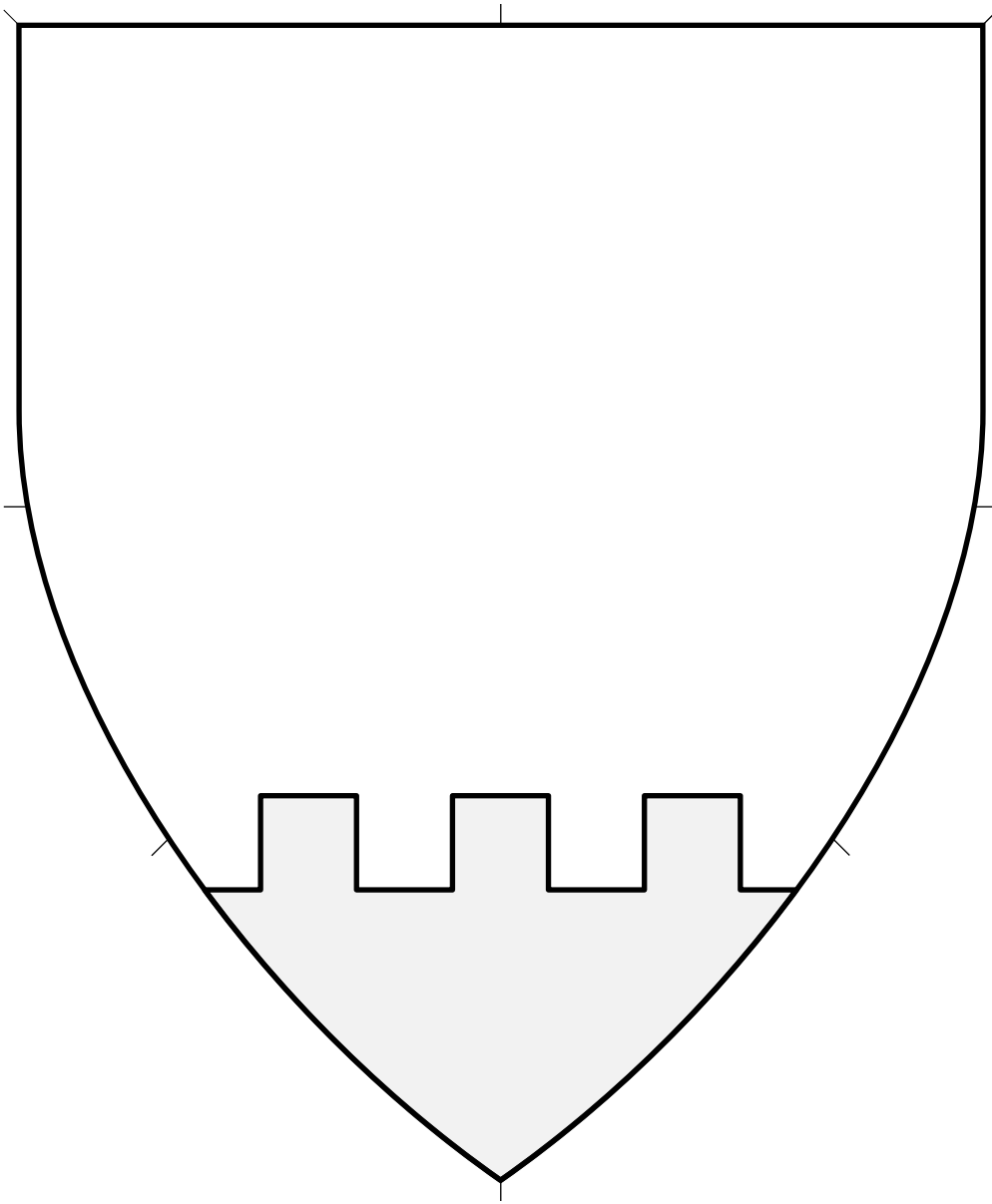

Peripheral ordinary.

Base Embattled (1) 4.31

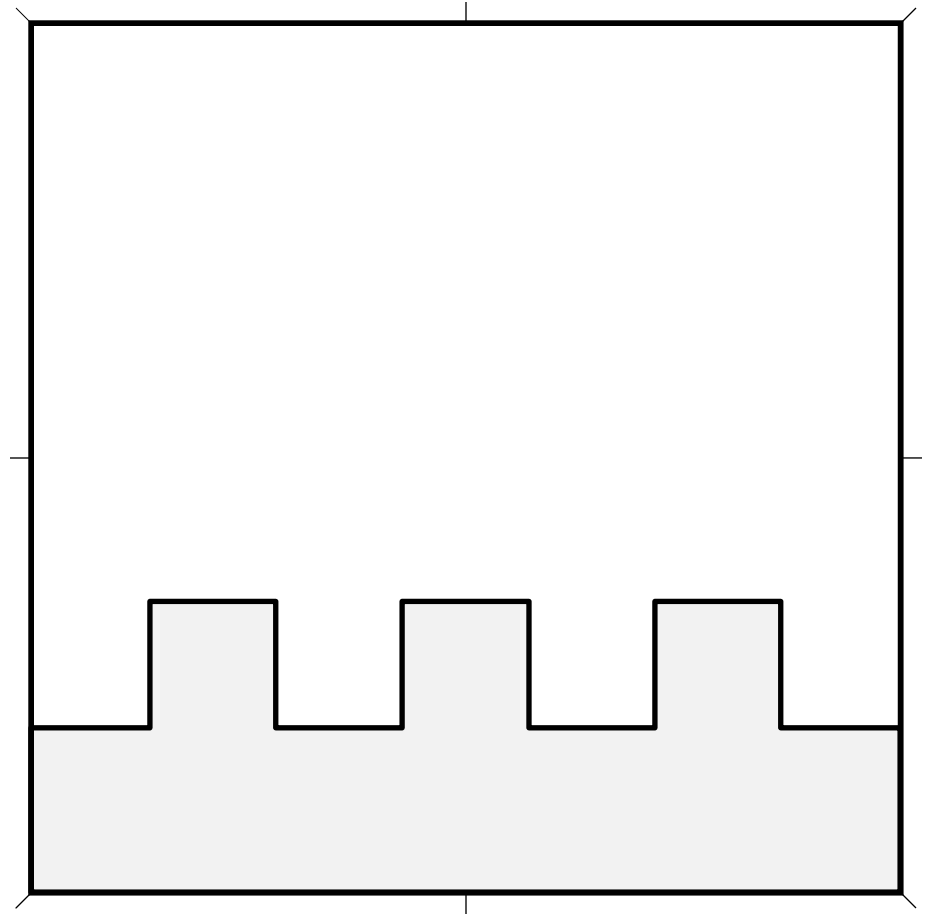
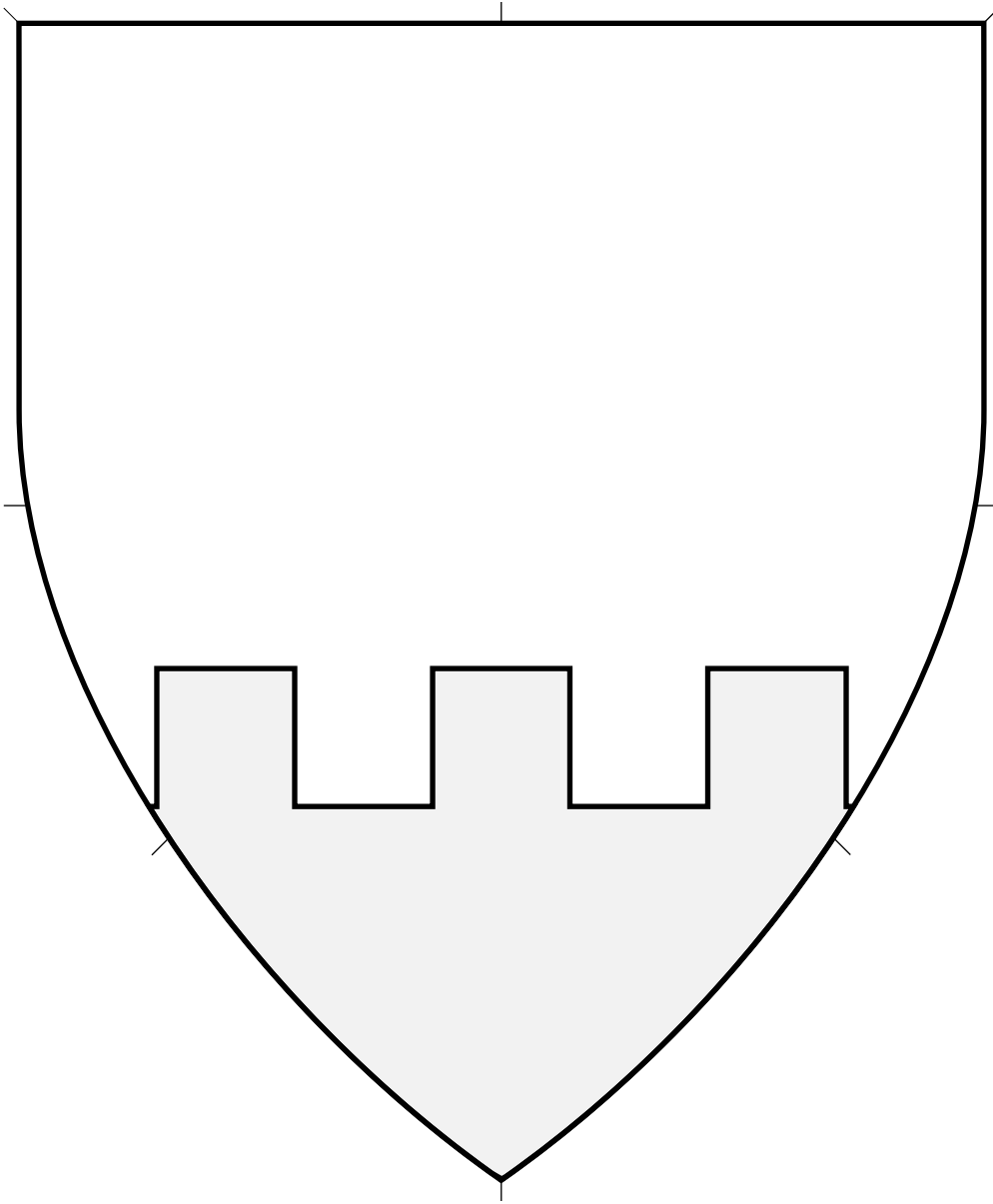

Peripheral ordinary.

Source: Viking Answer Lady SVG Images For Heraldry.
Artist: Gunnvôr silfrahárr. Adapted by Mathghamhain Ua Ruadháin.

Base Embattled (2) 4.32

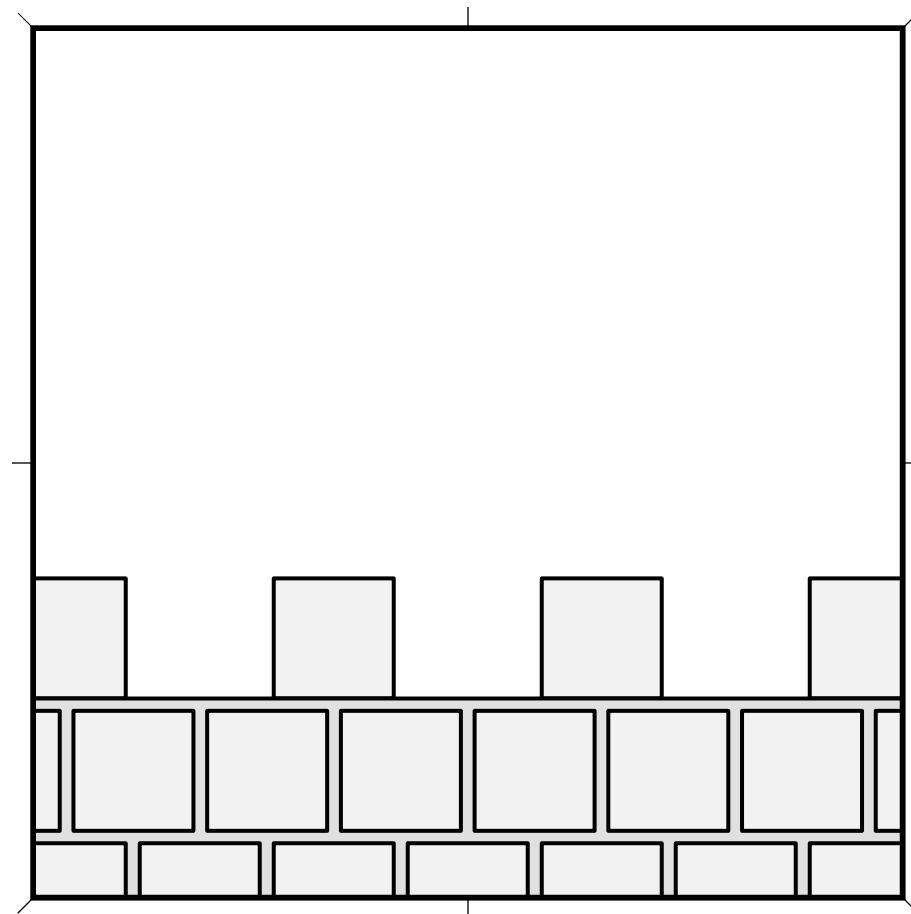
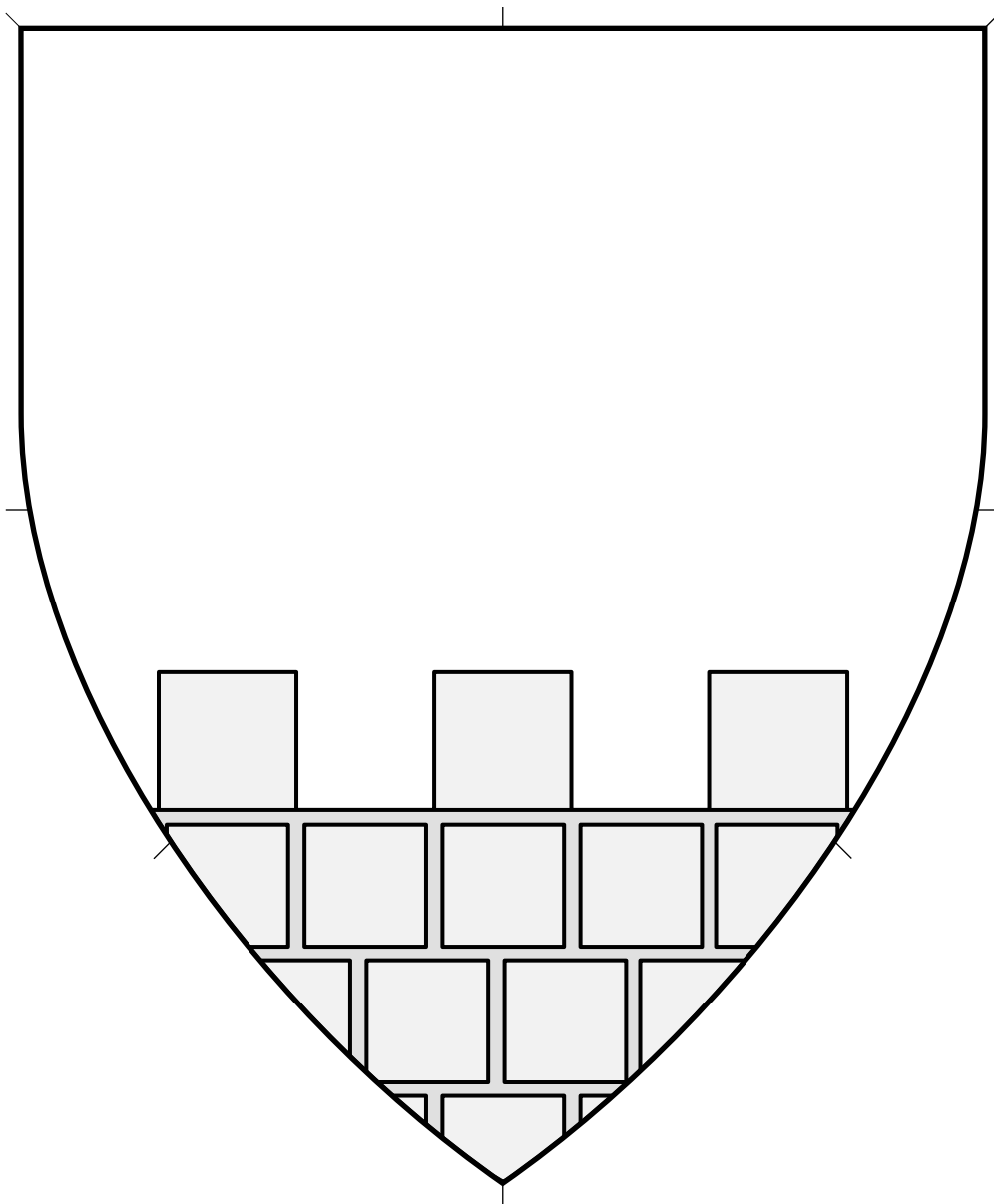

Peripheral ordinary.
Artist: Vémundr Syvursson.

Base Embattled and Masoned 4.33

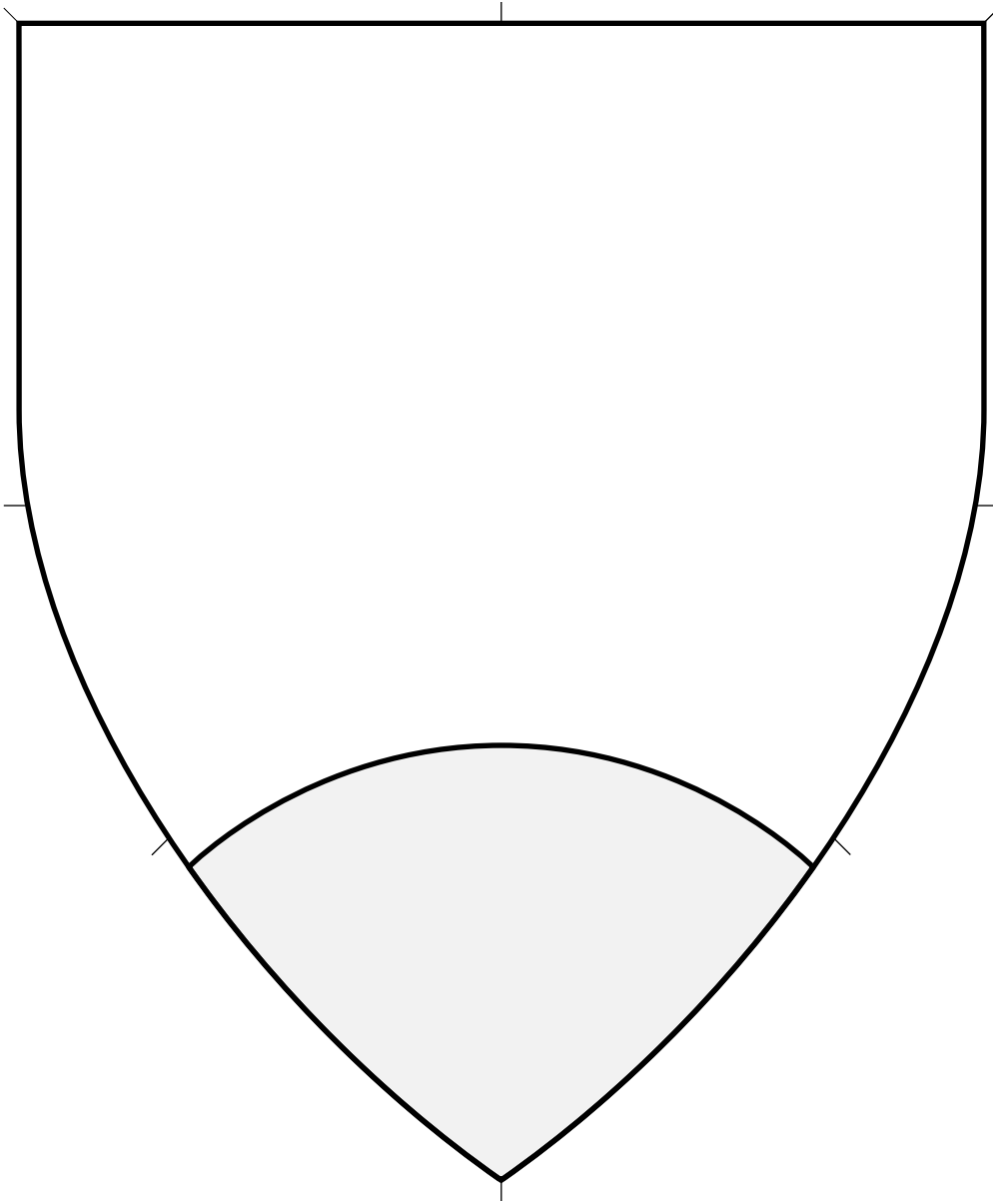

Peripheral ordinary.

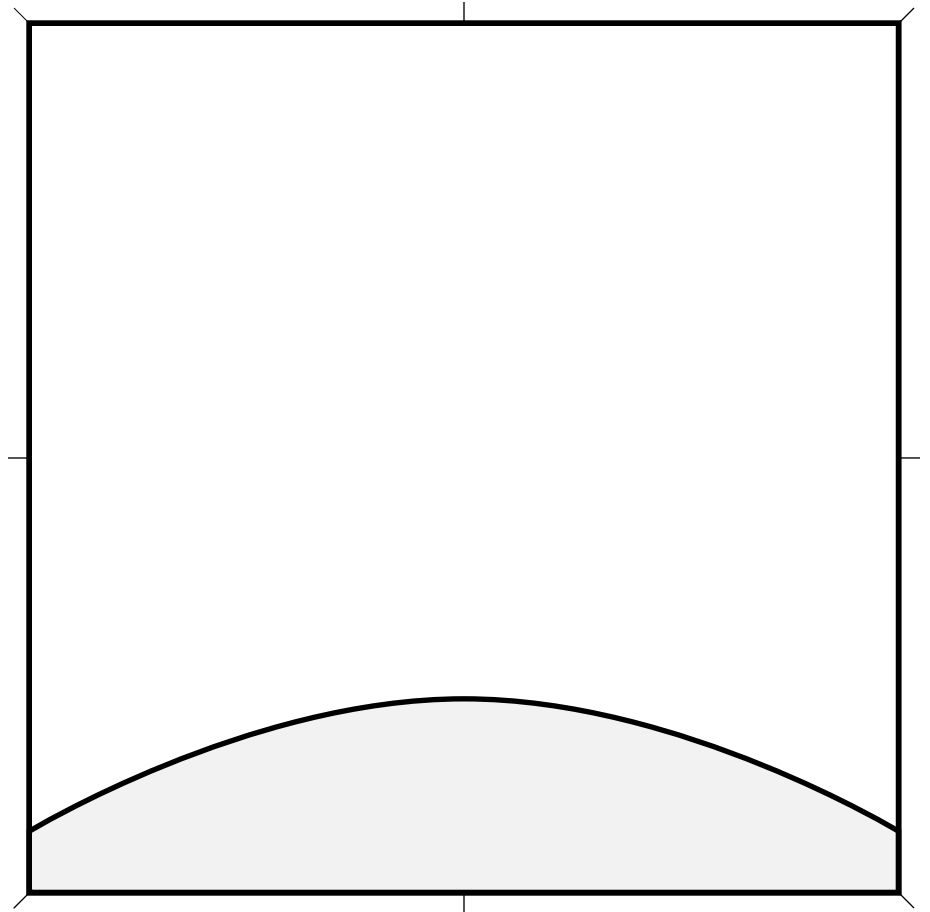

Base Enarched 4.34

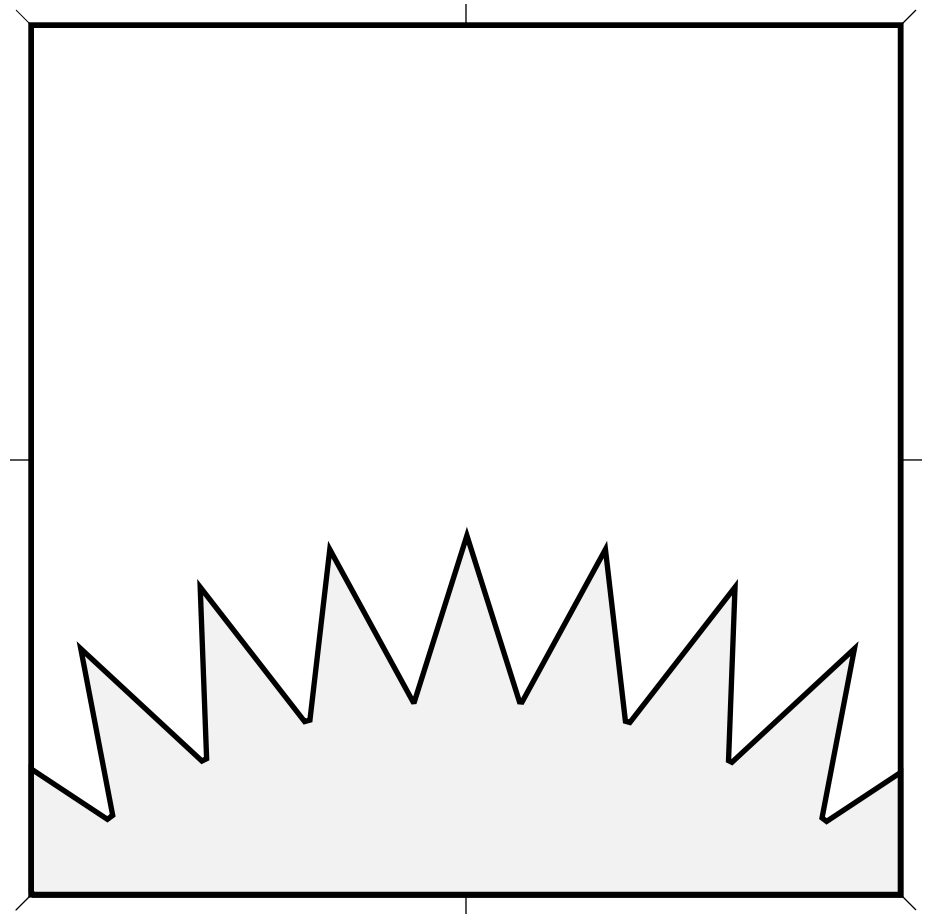
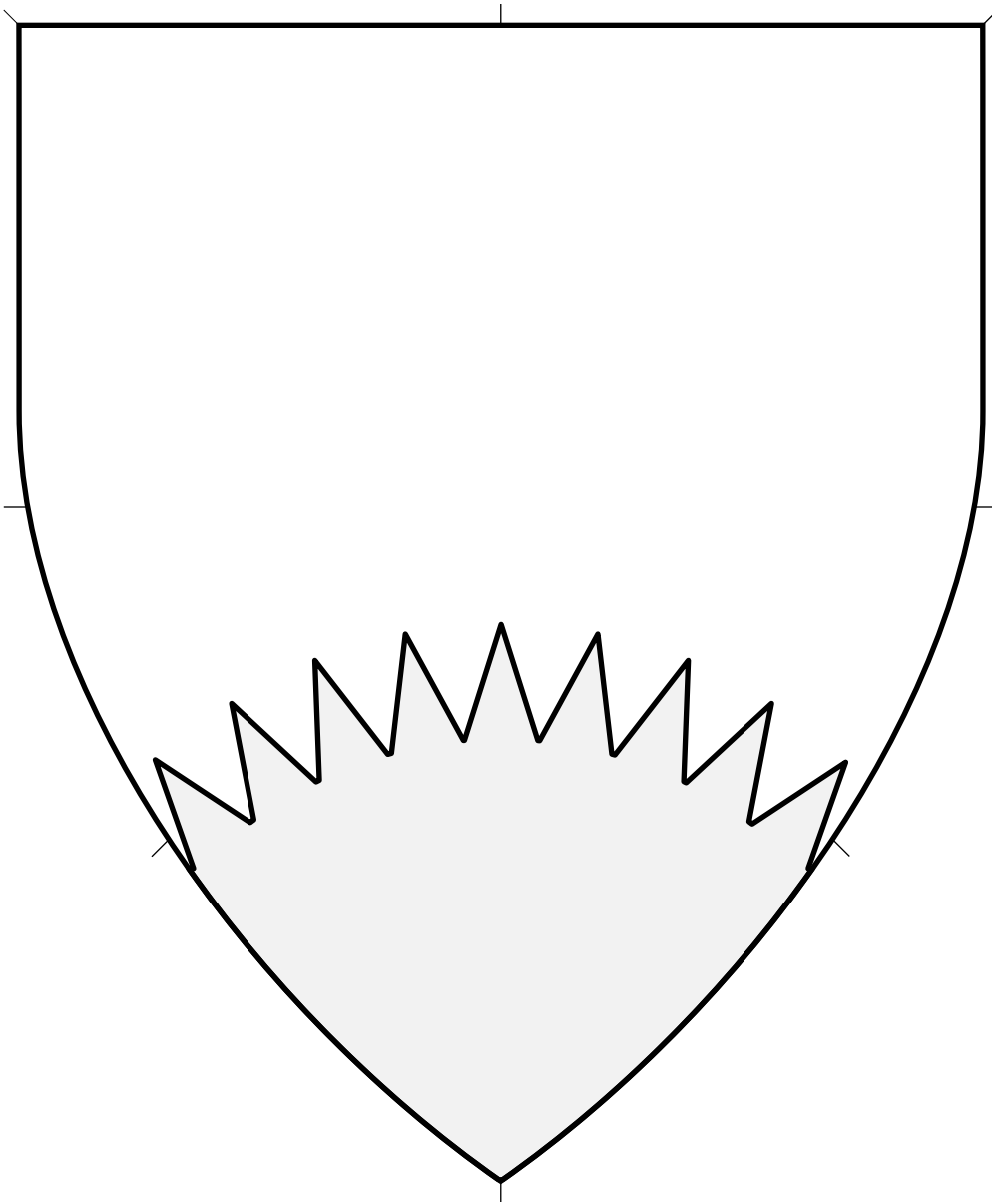

Peripheral ordinary.

Source: Viking Answer Lady SVG Images For Heraldry.
Artist: Gunnvôr silfrhárr.

Base Enarched Indented 4.35

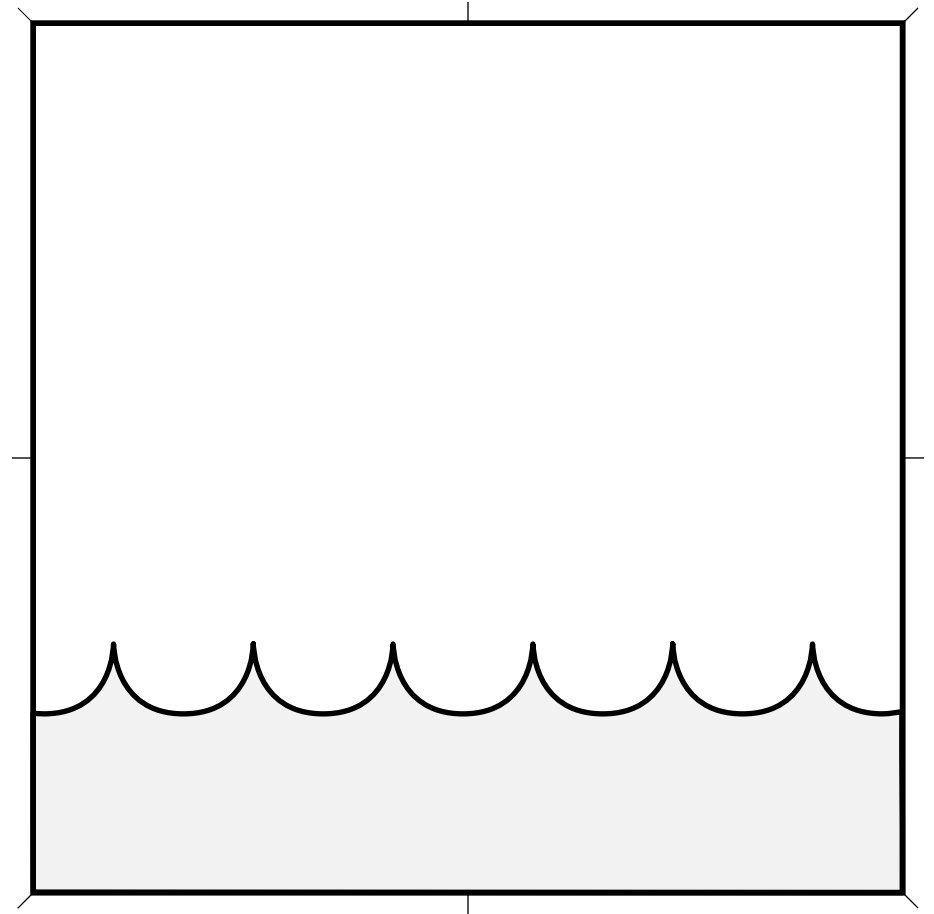
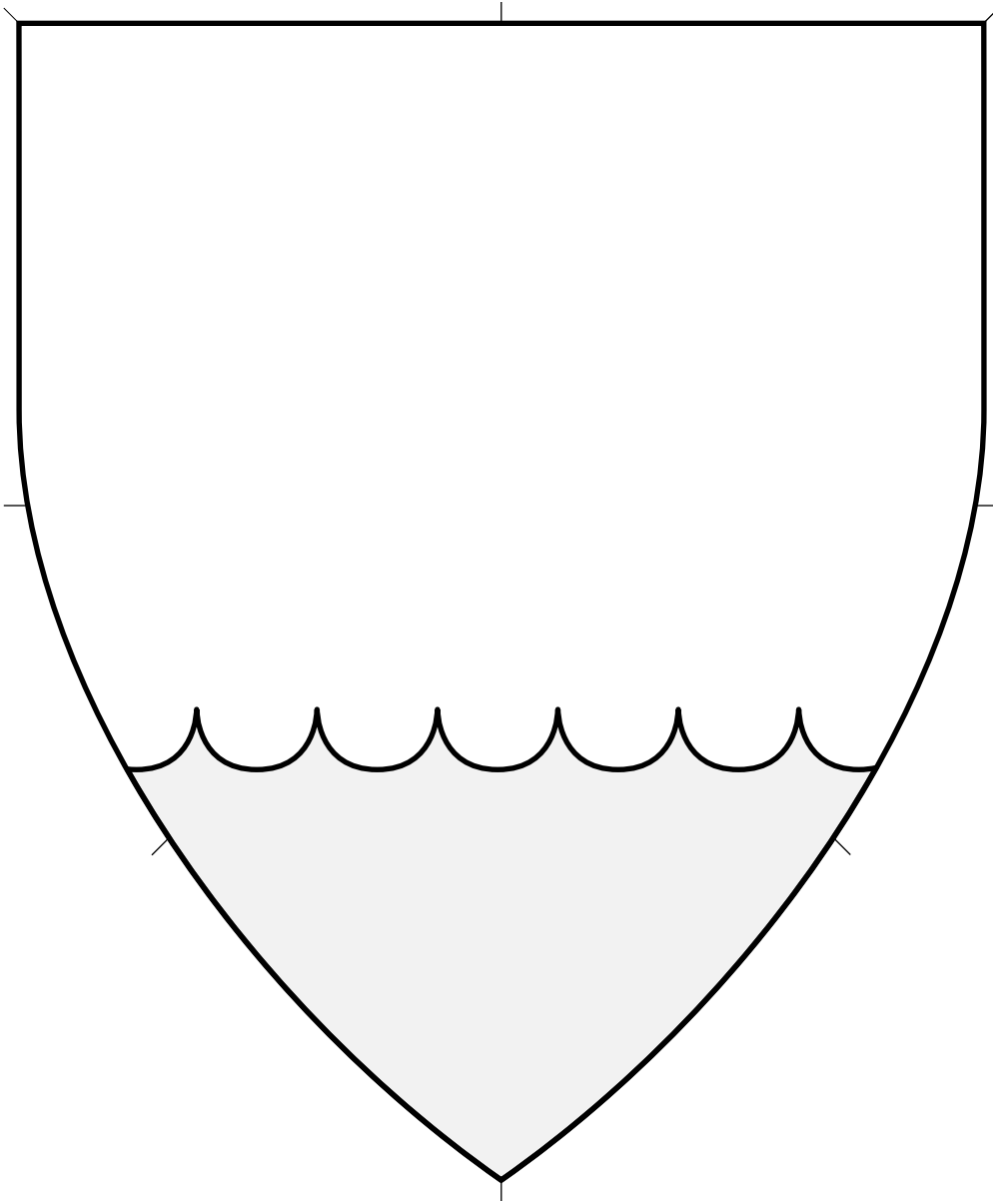

Peripheral ordinary.

Artist: Vémundr Syvursson. Adapted by Mathghamhain Ua Ruadháin.

Base Engrailed (1) 4.36

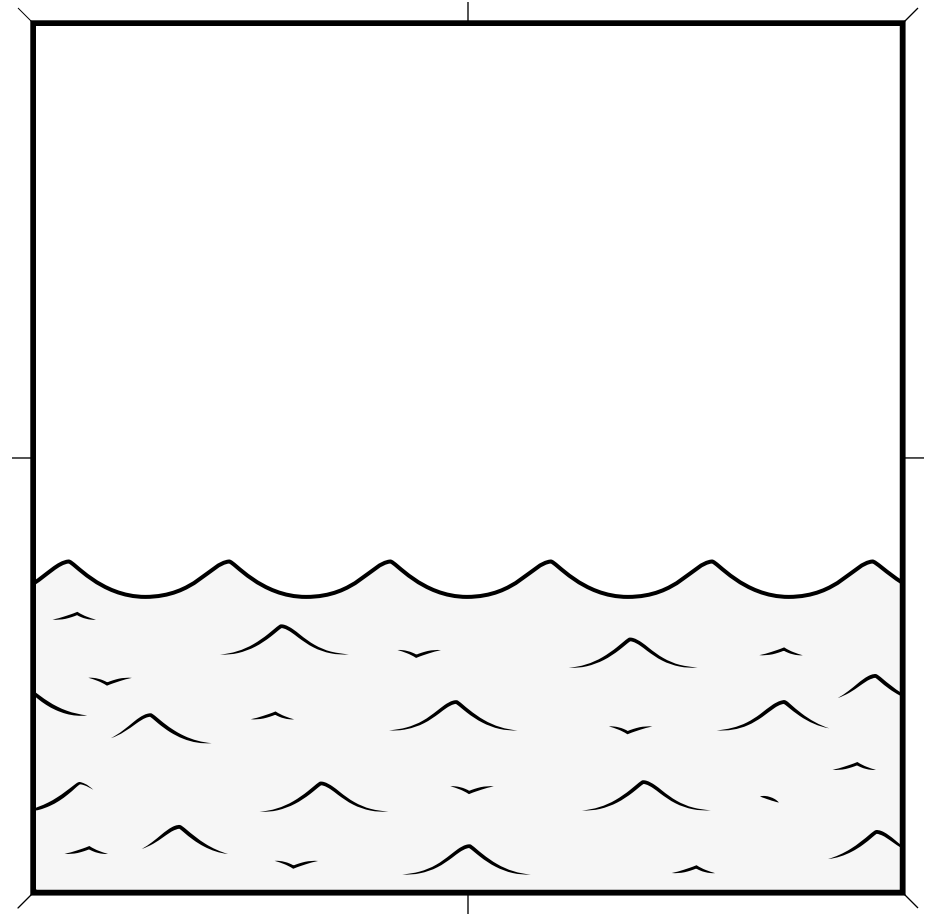
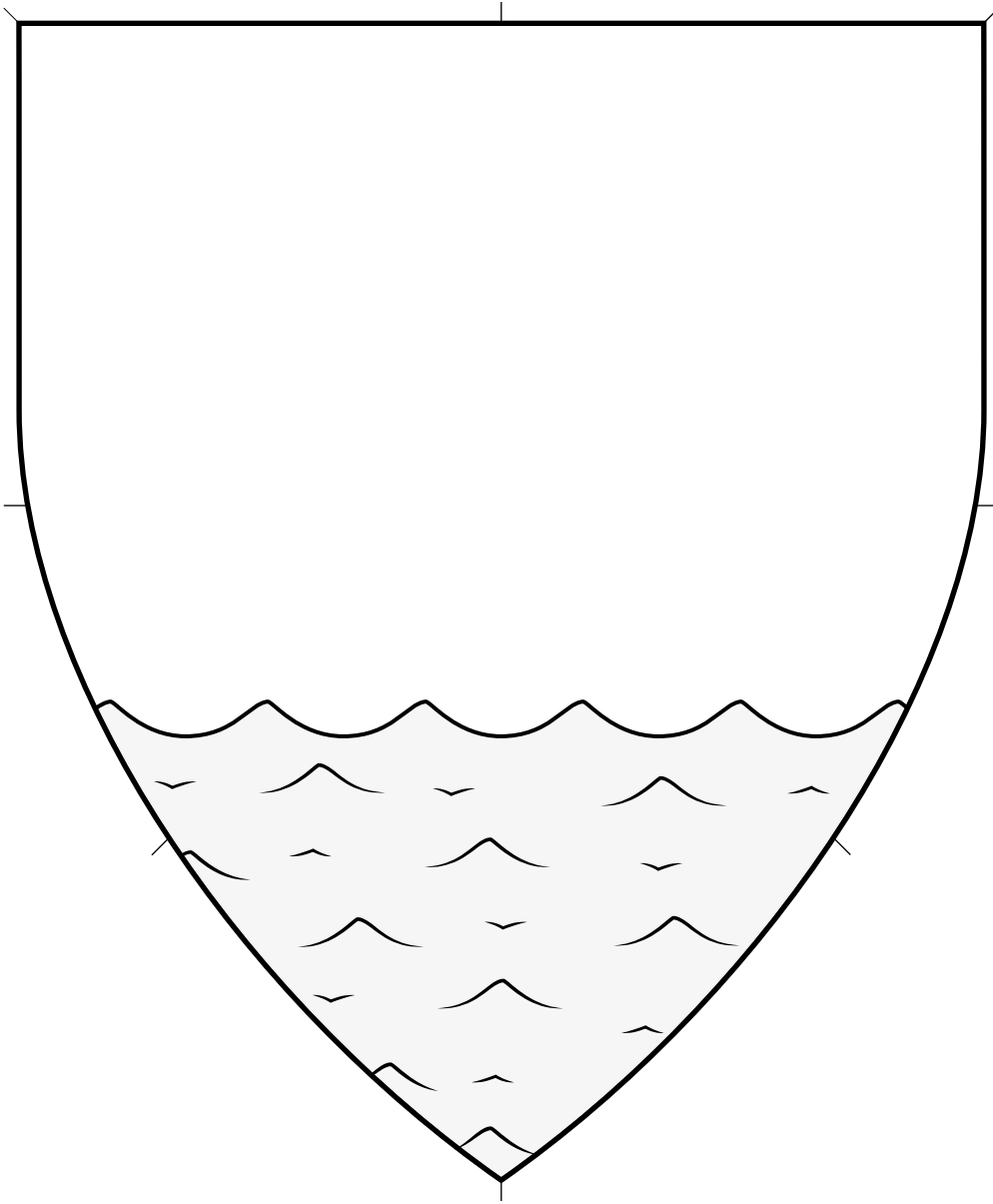

Peripheral ordinary.

Source: WappenWiki. Artist: Joakim Spuller.

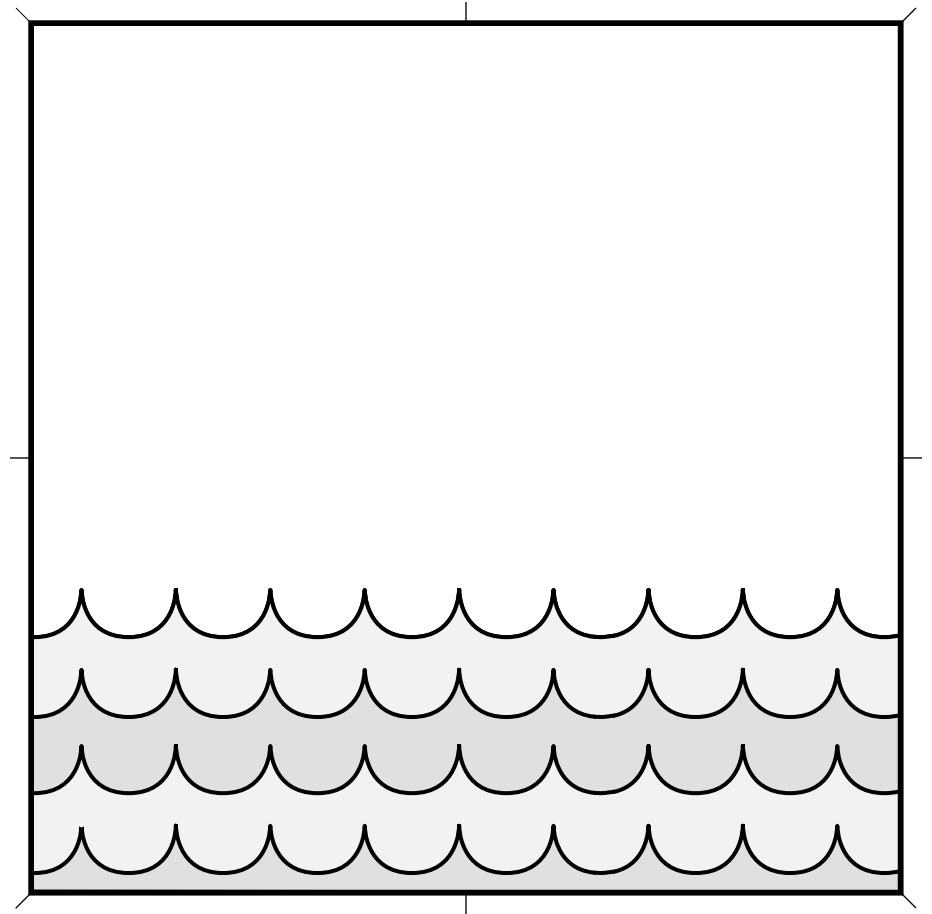
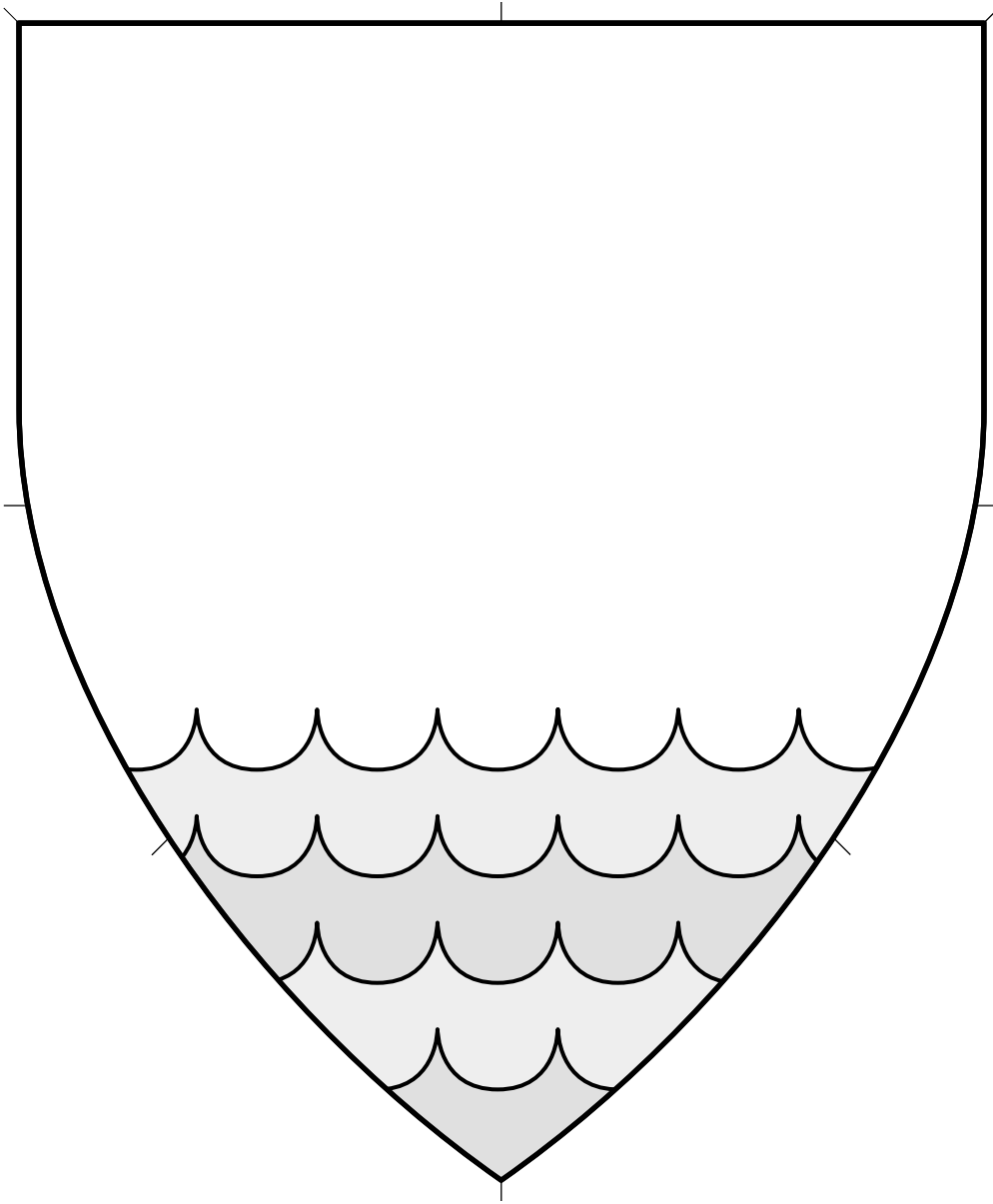

Peripheral ordinary.

Artist: Vémundr Syvursson.

Adapted by Mathghamhain Ua Ruadháin.

Base Engrailed Barry Engrailed 4.38

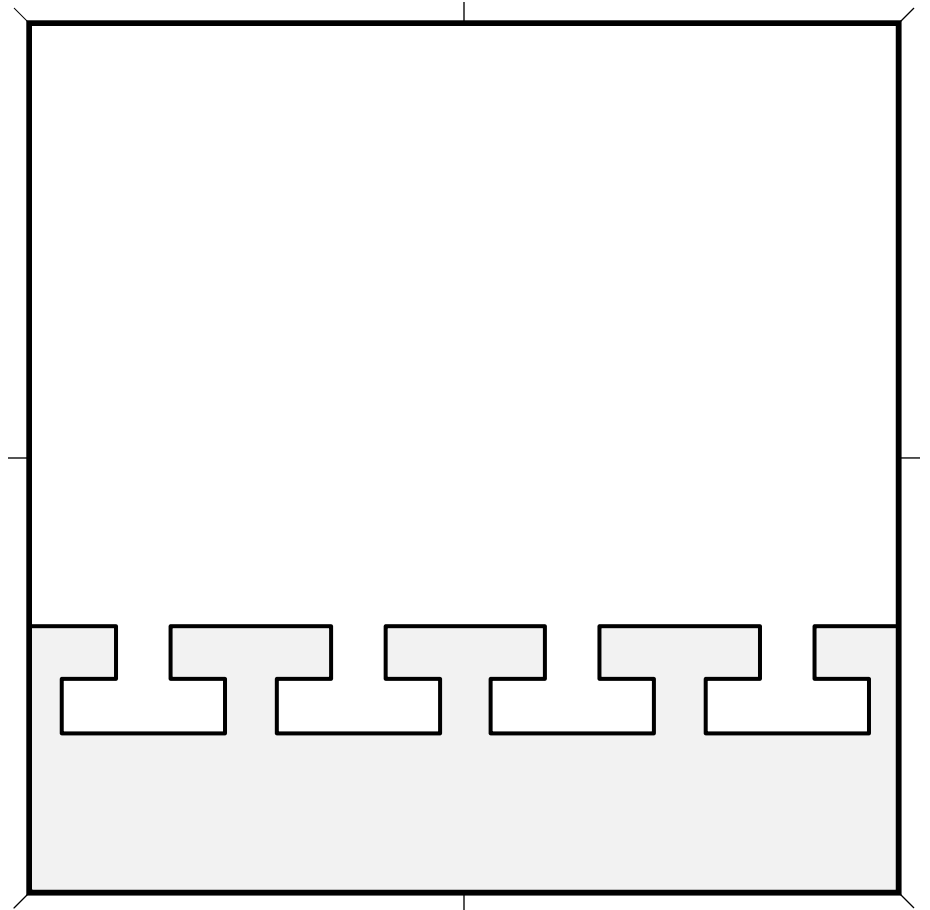
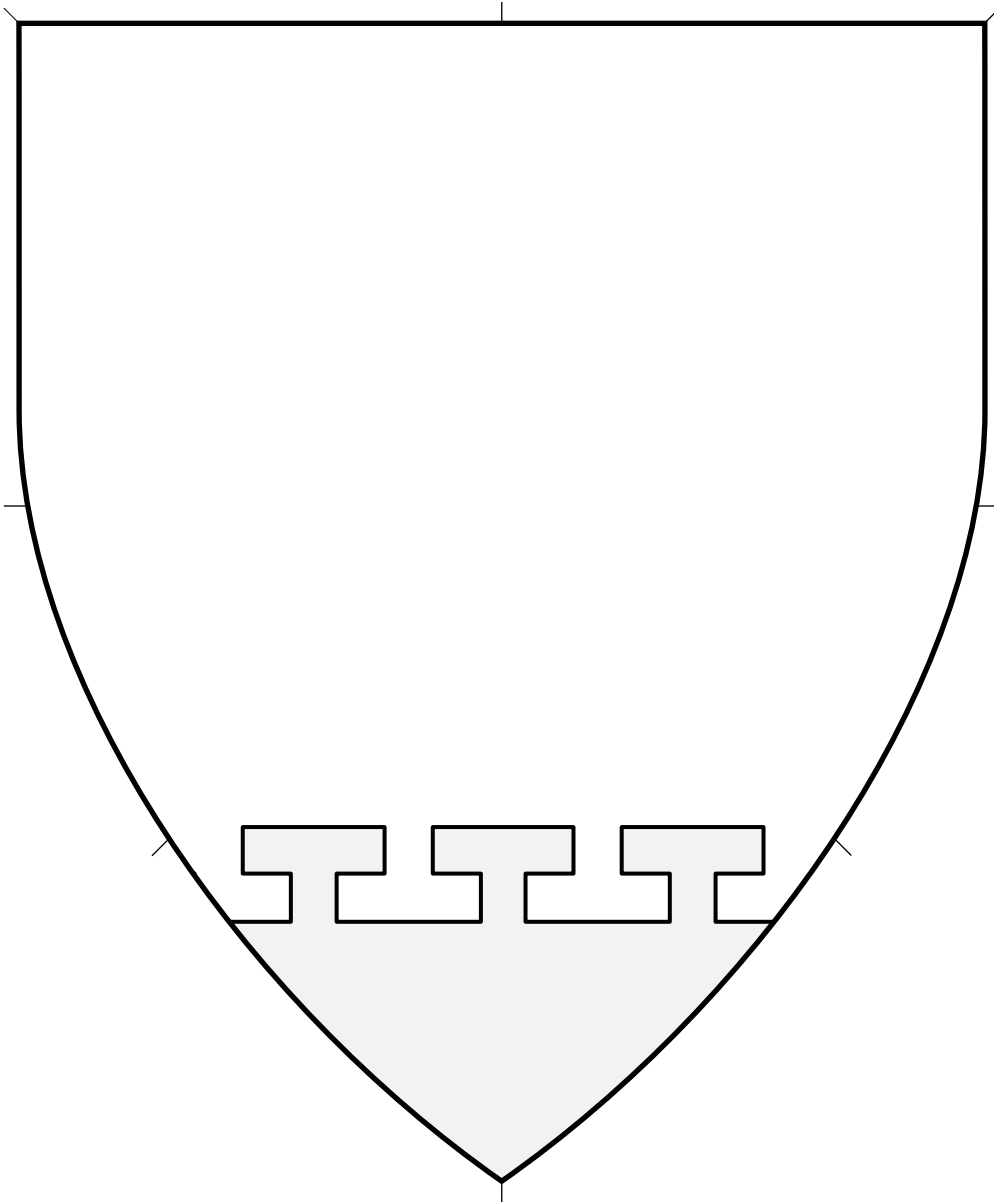

Peripheral ordinary.

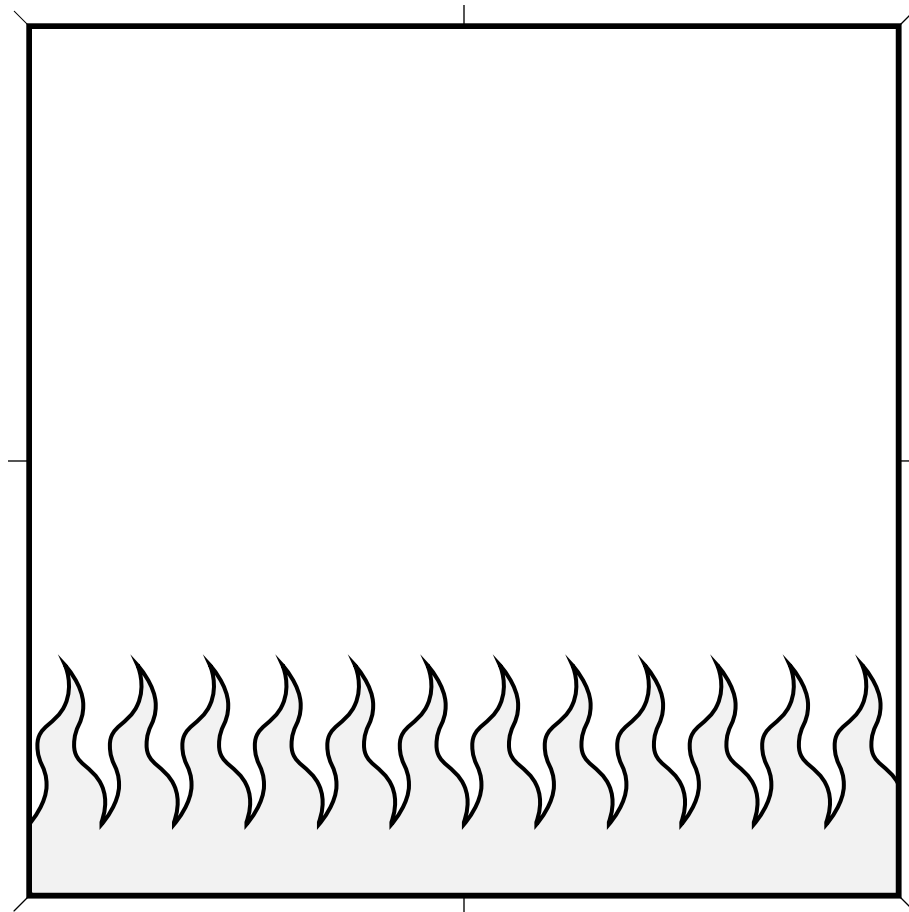
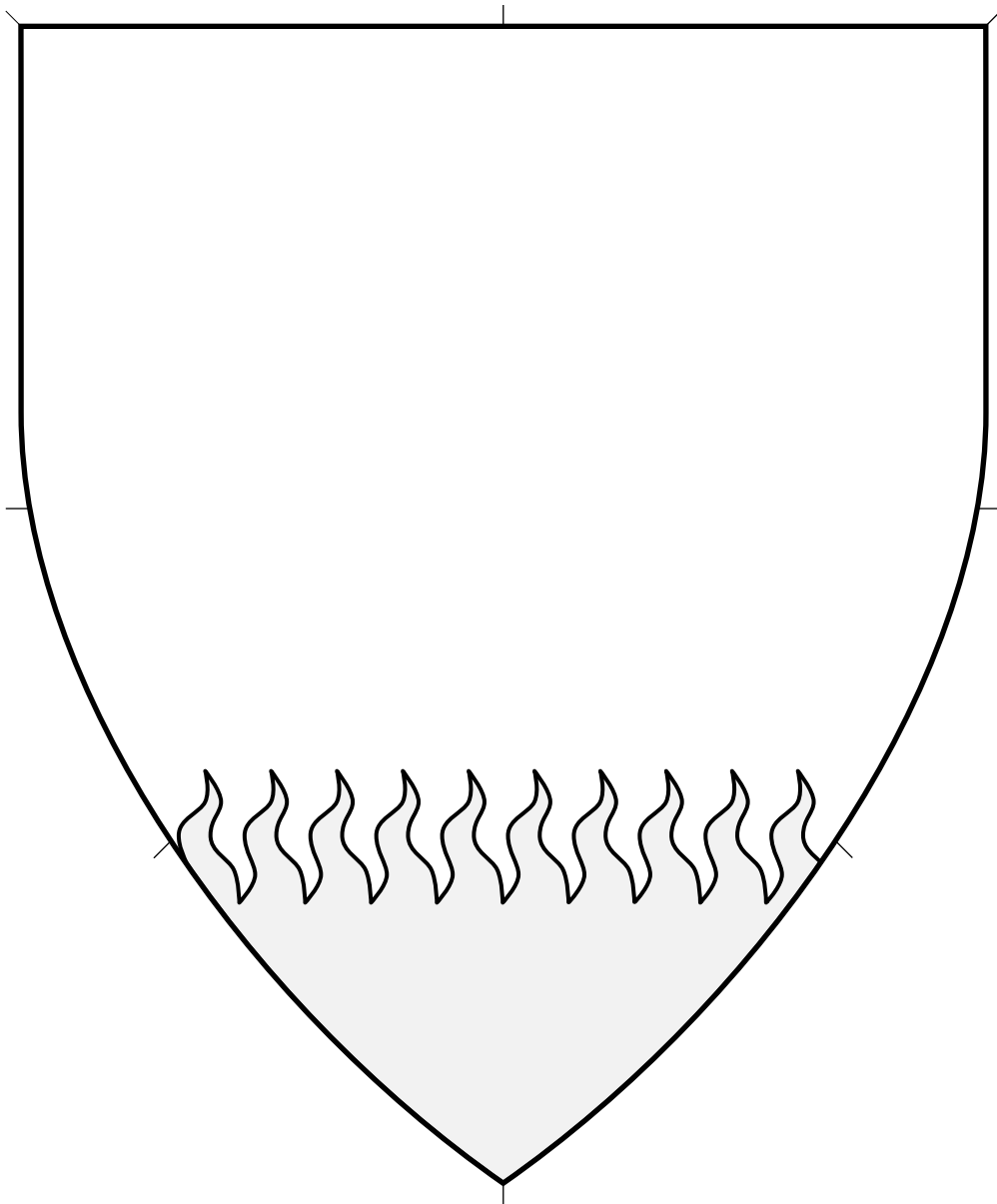

Peripheral ordinary.
Artist: Vémundr Syvursson.

Base Rayonny 4.40

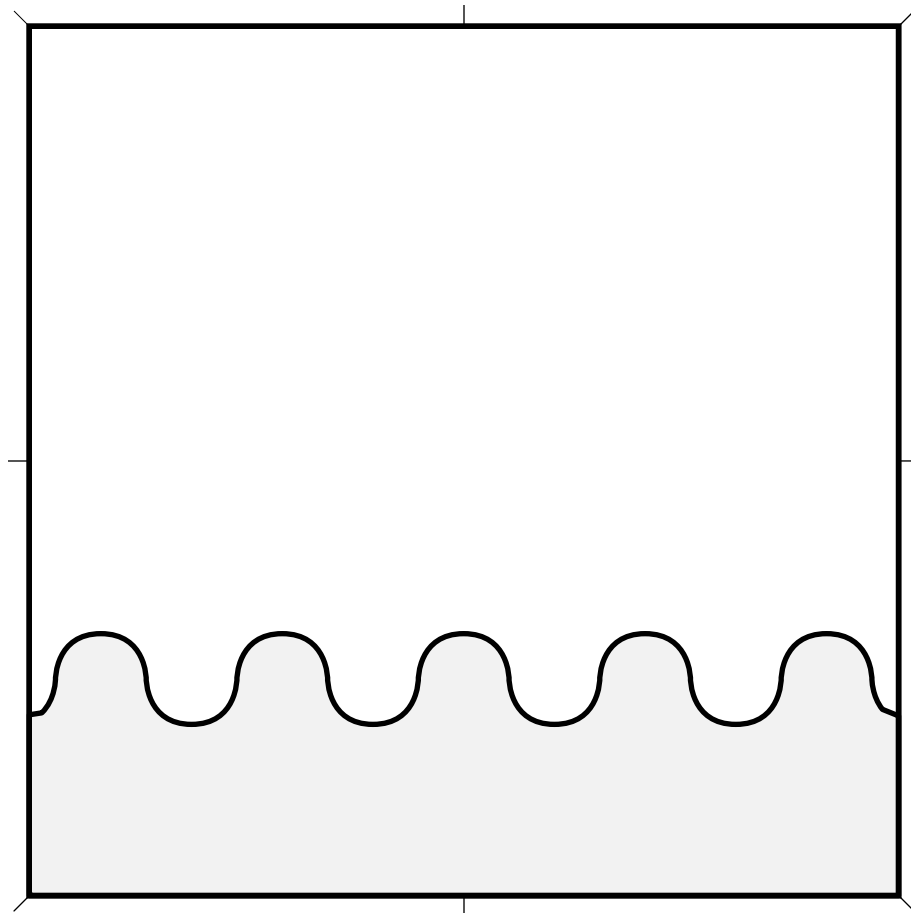
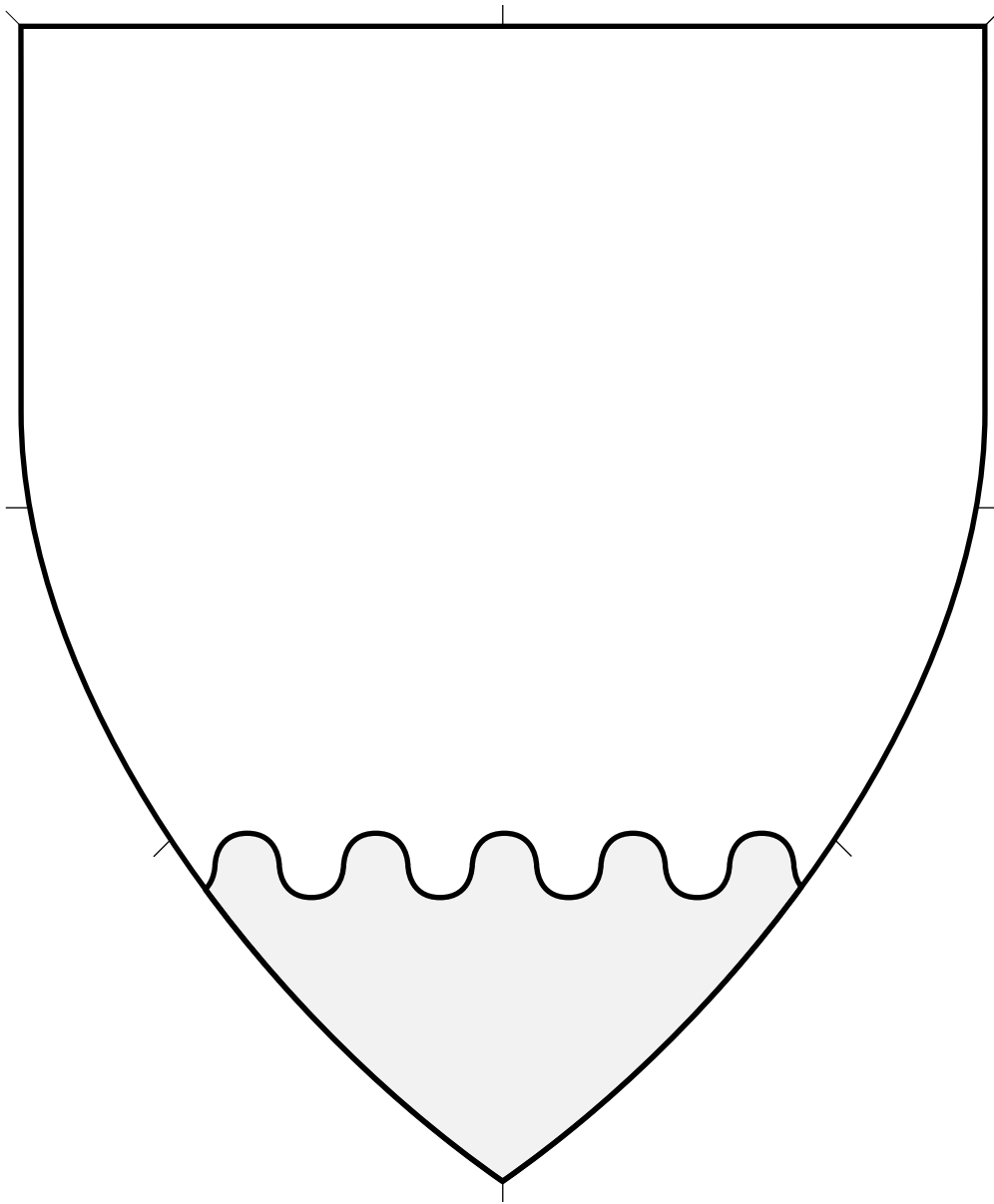

Peripheral ordinary.
Artist: Vémundr Syvursson.

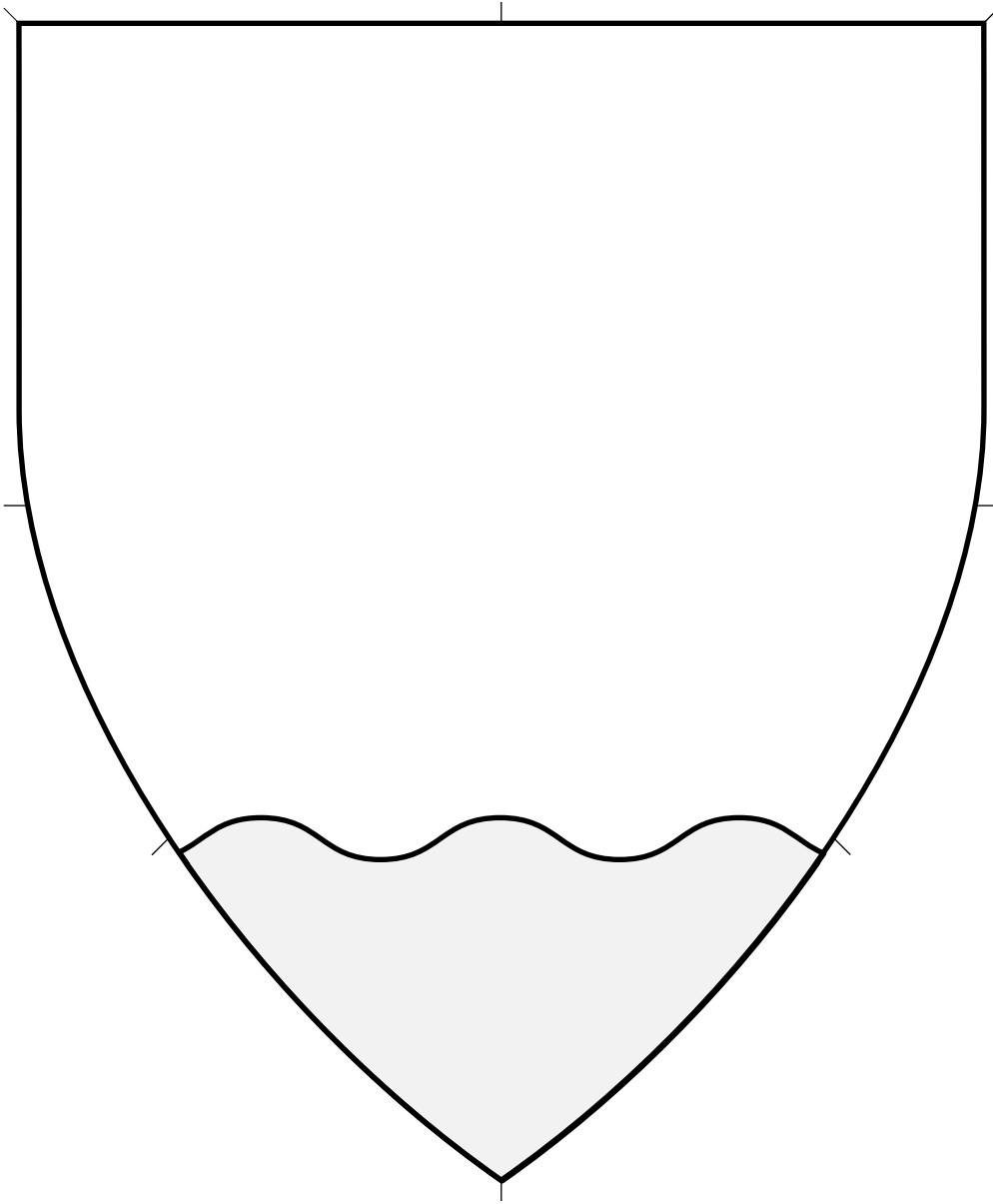

Peripheral ordinary.

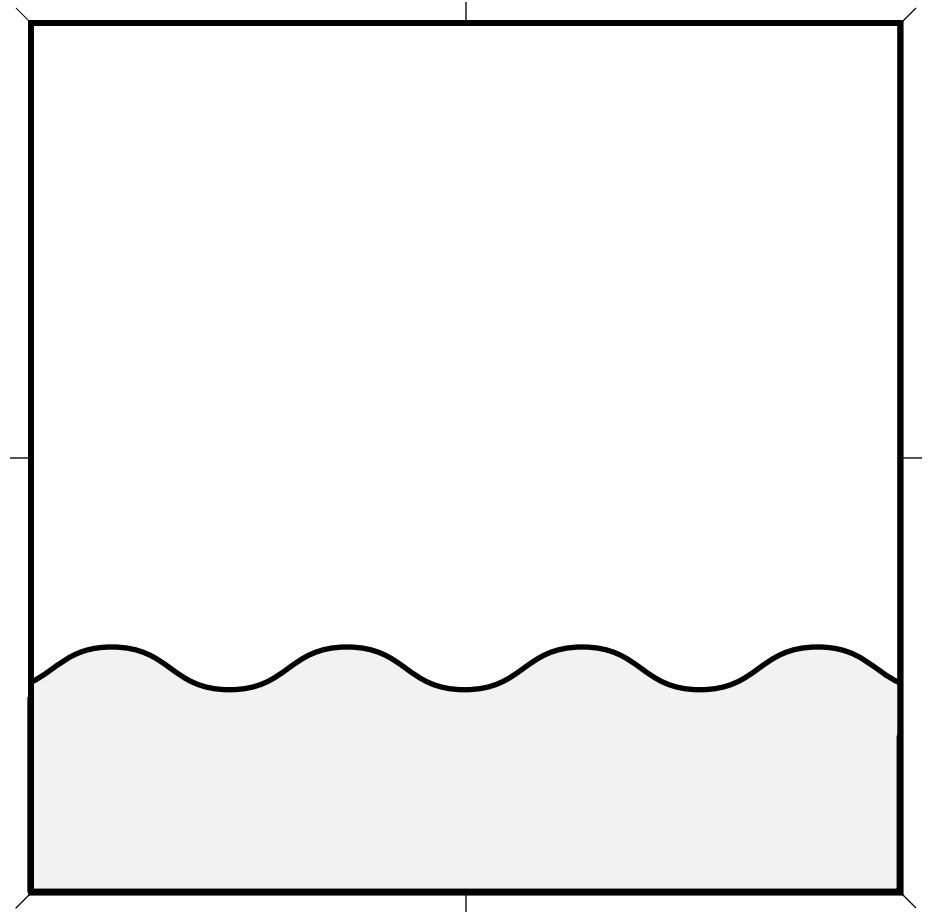

Base Wavy (2) 4.42

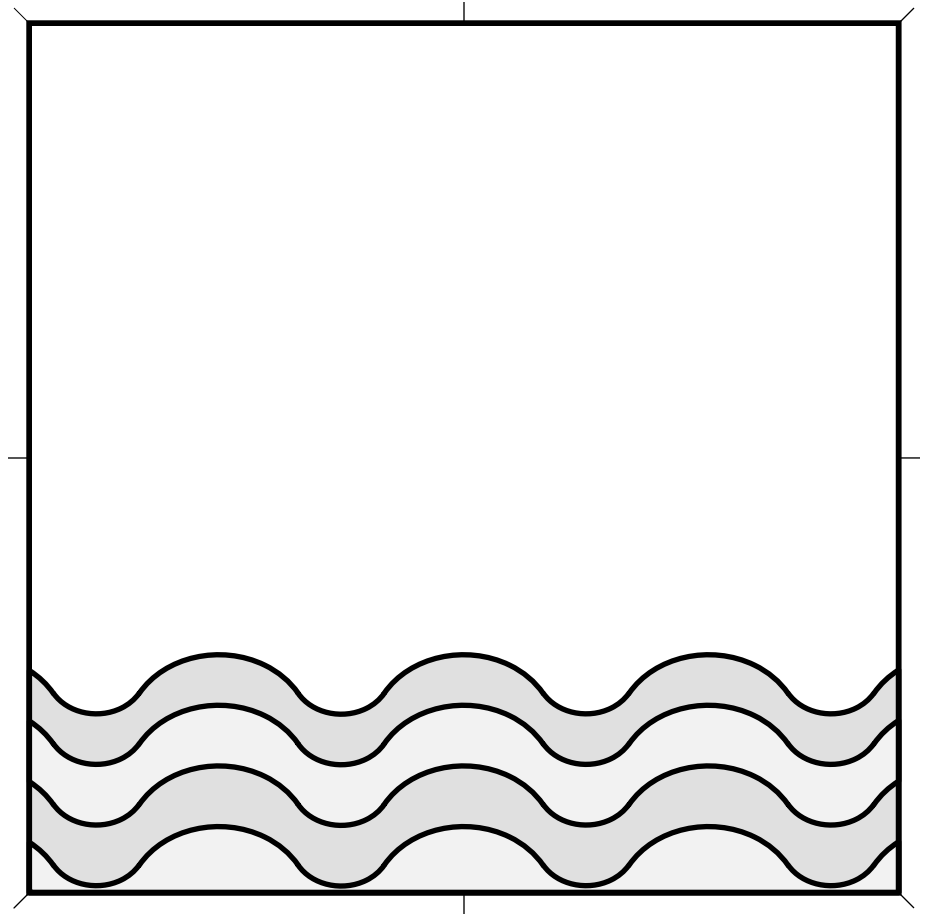
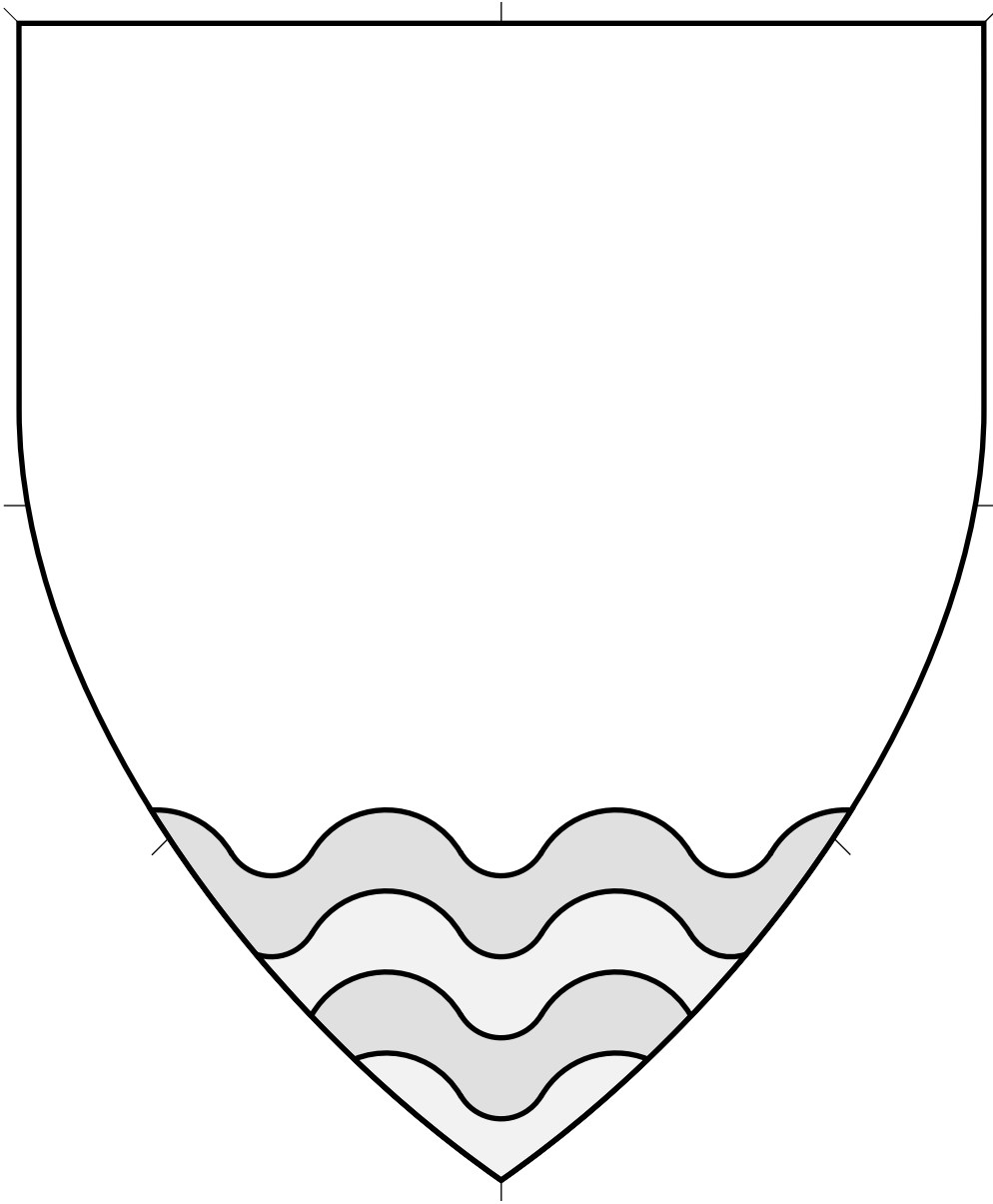

Peripheral ordinary.
Blazoned "a ford proper" if azure and argent.

Base Wavy Barry Wavy (1) 4.43

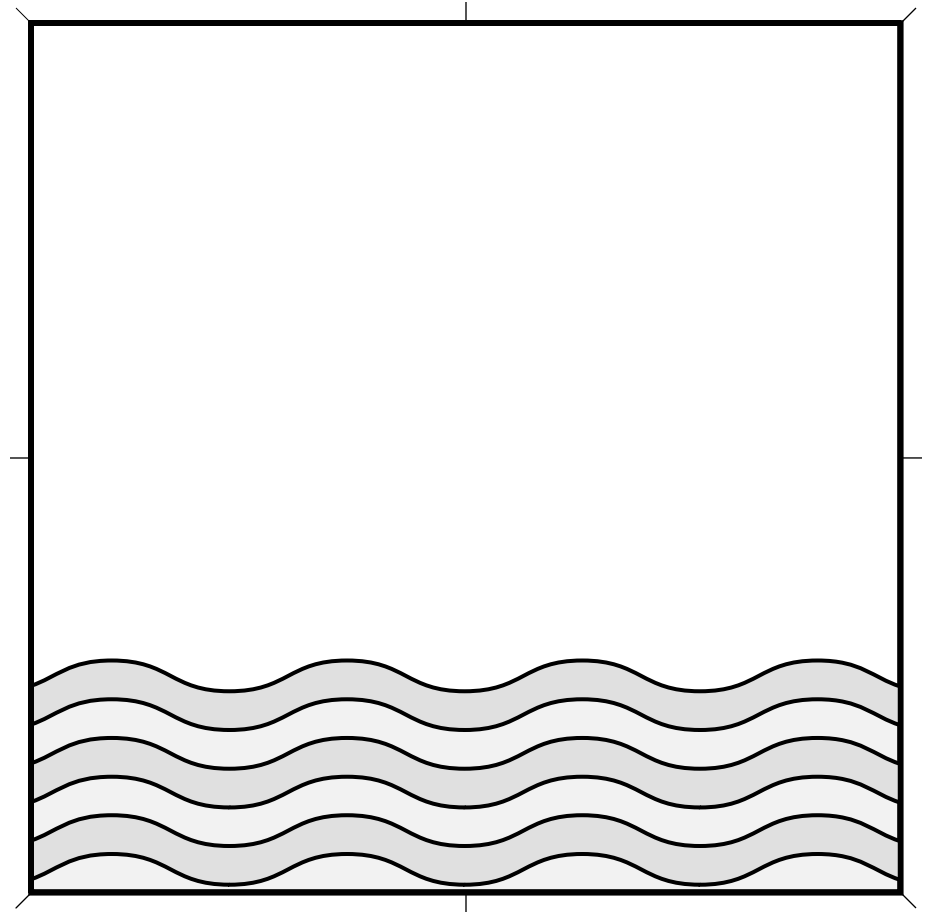
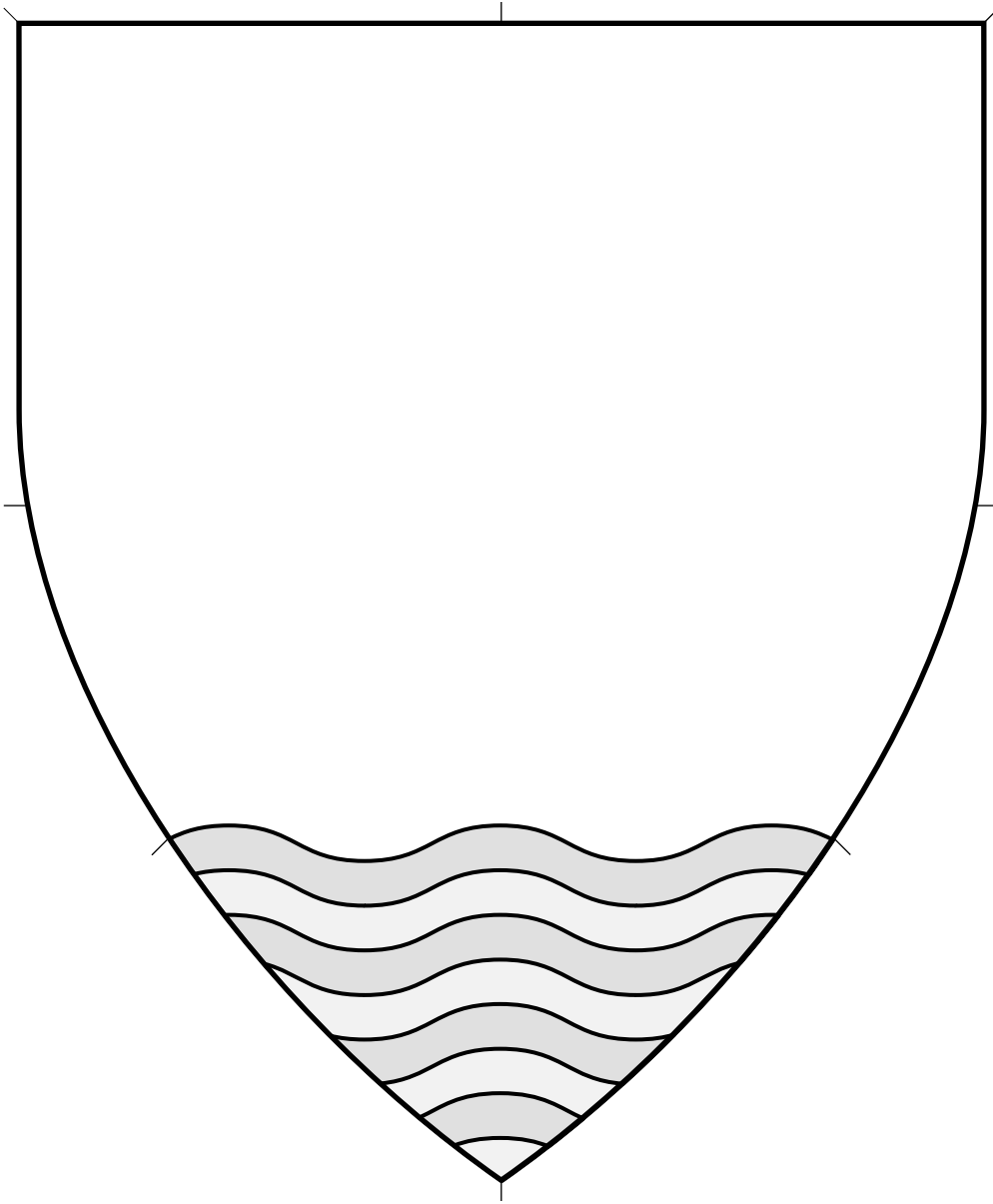

Peripheral ordinary.
Blazoned "a ford proper" if azure and argent.

Base Wavy Barry Wavy (2) 4.44

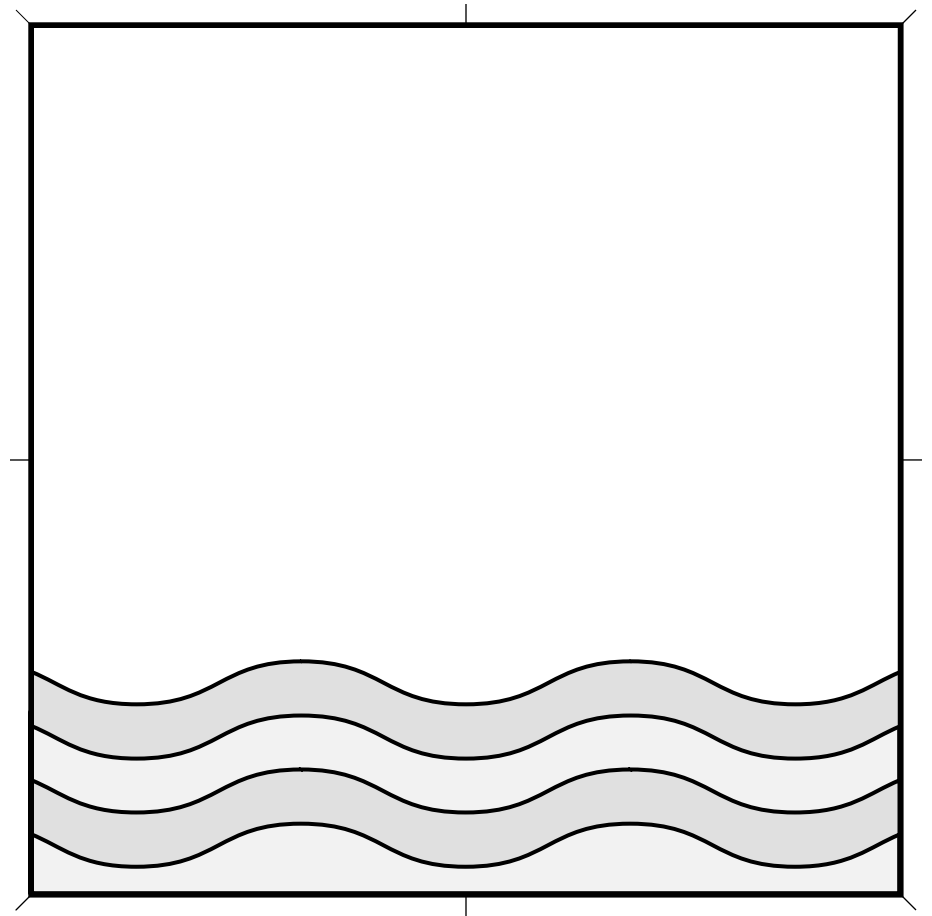
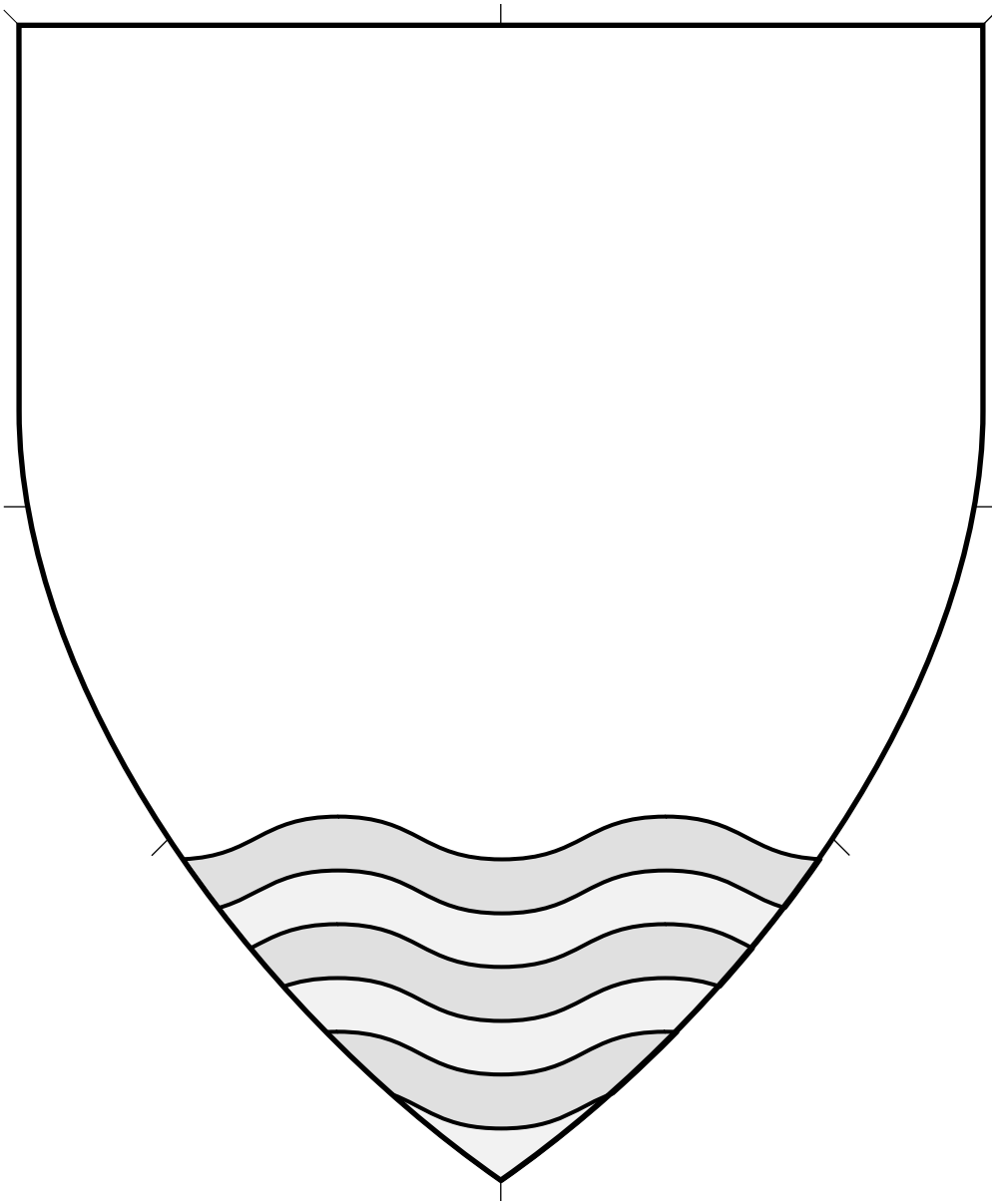

Peripheral ordinary.
Blazoned "a ford proper" if azure and argent.

Base Wavy Barry Wavy (3) • 4.45

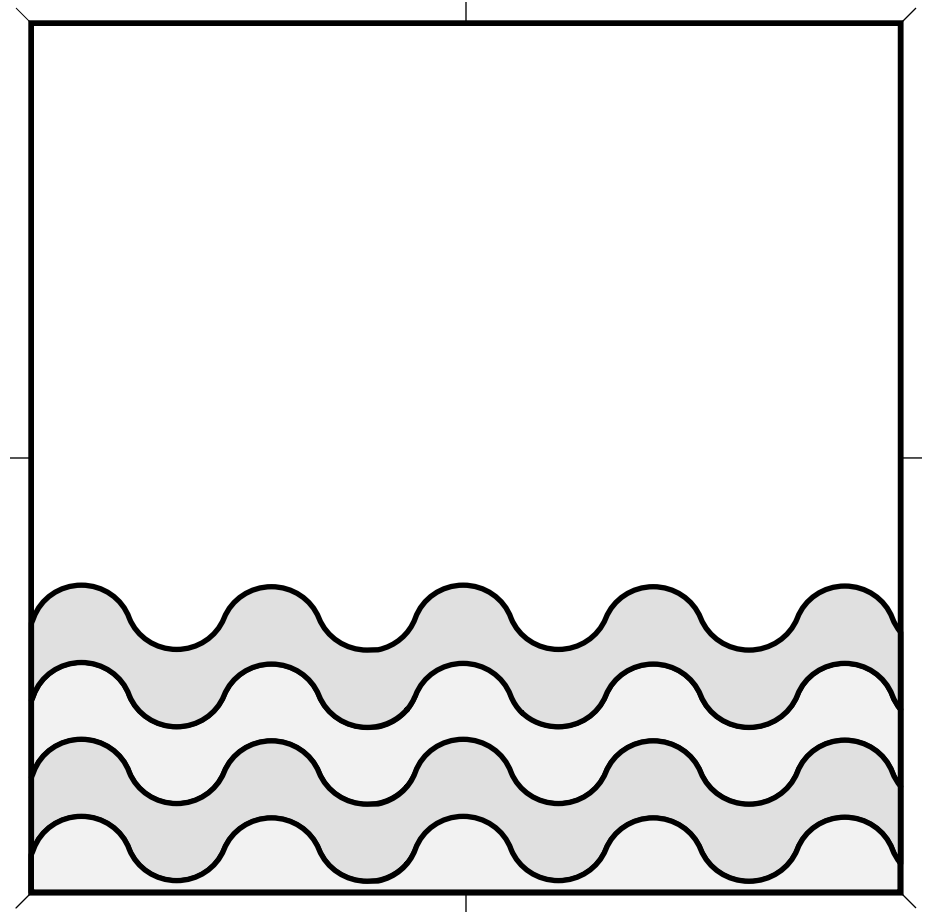
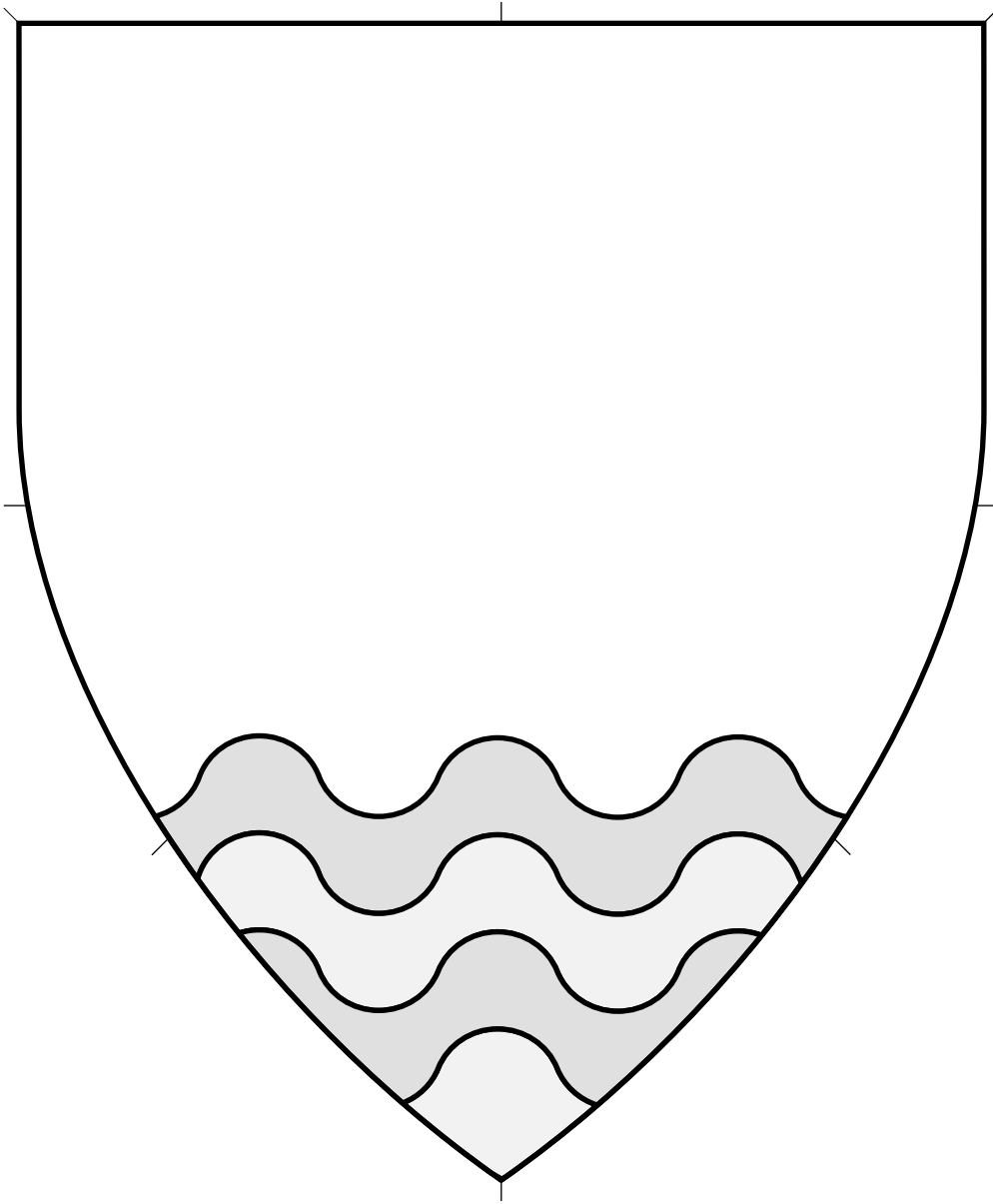

Peripheral ordinary. Blazoned “a ford proper” if azure and argent.

Source: Viking Answer Lady SVG Images For Heraldry.

Artist: Gunnvör silfrhárr.

Adapted by Mathghamhain Ua Ruadháin.

Base Wavy Barry Wavy (4) 4.46

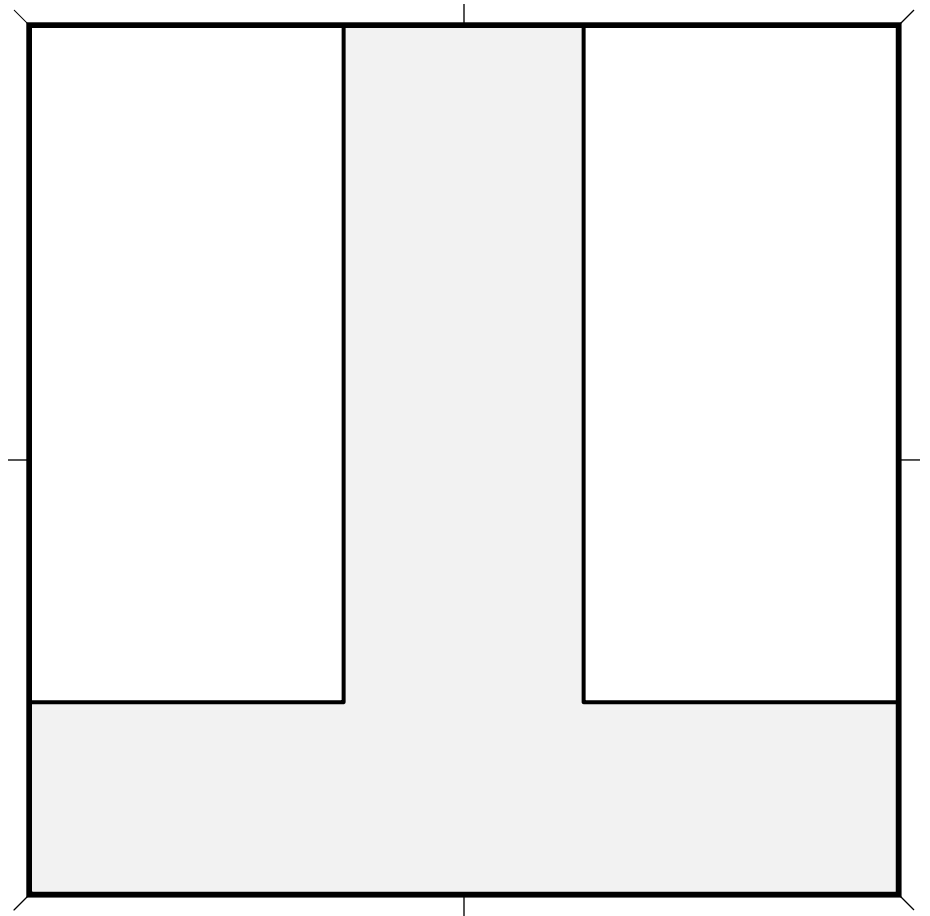
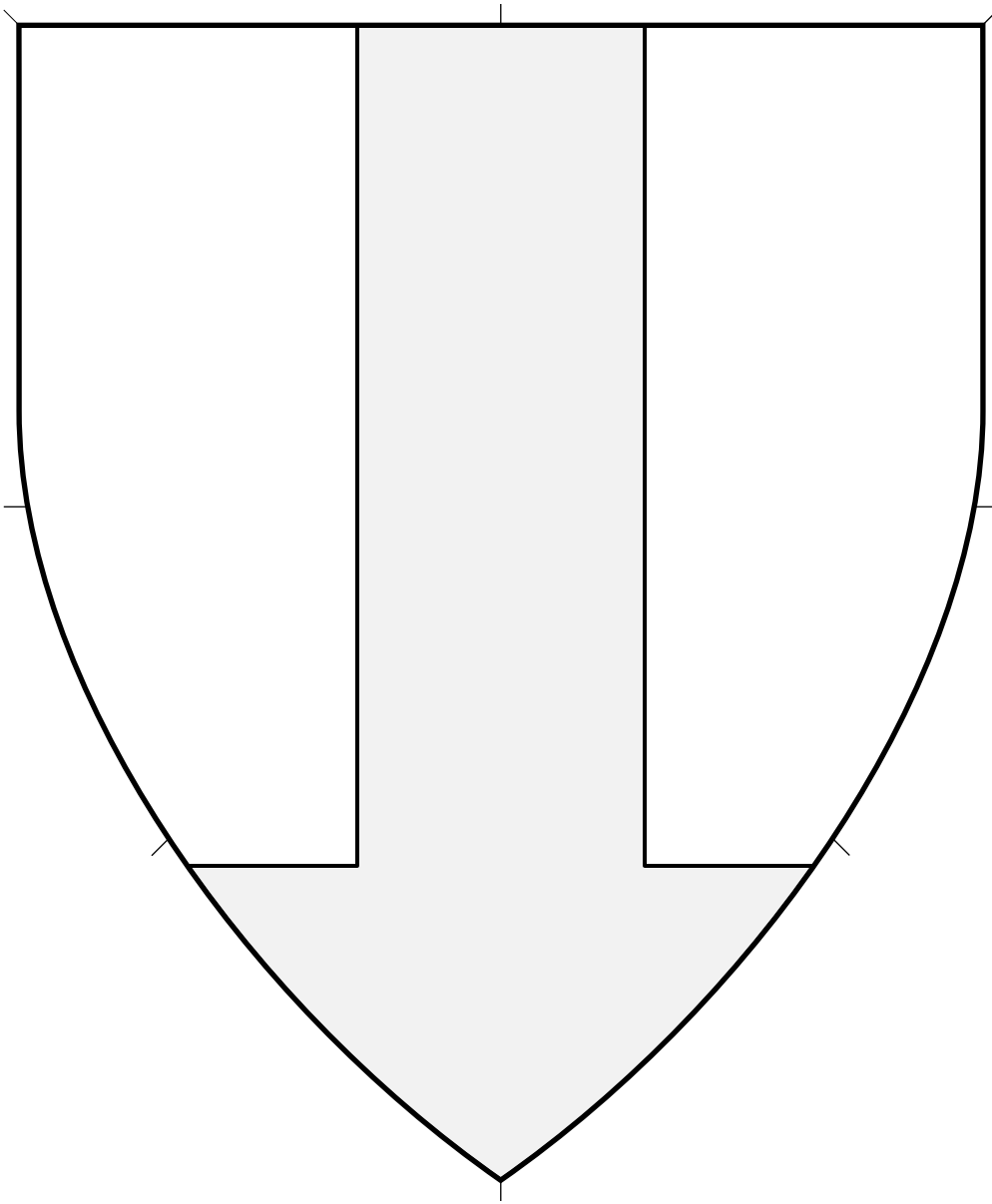

Two ordinaries combined.

Base and Pale Conjoined 4.47

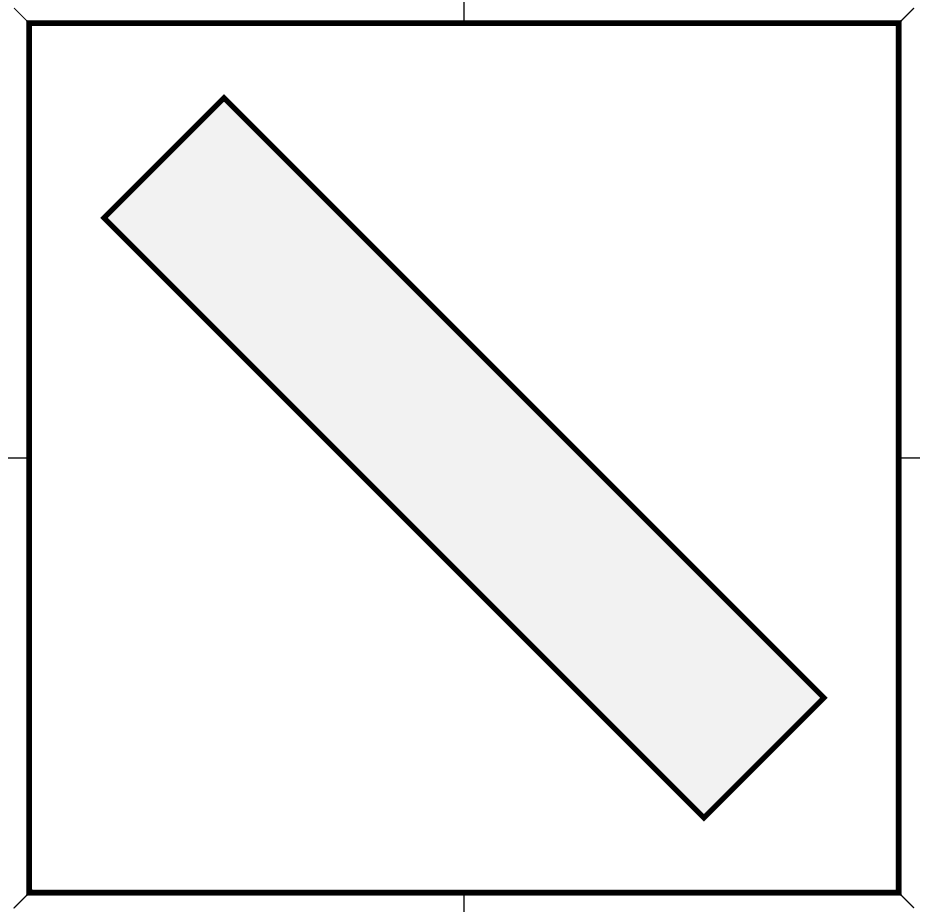
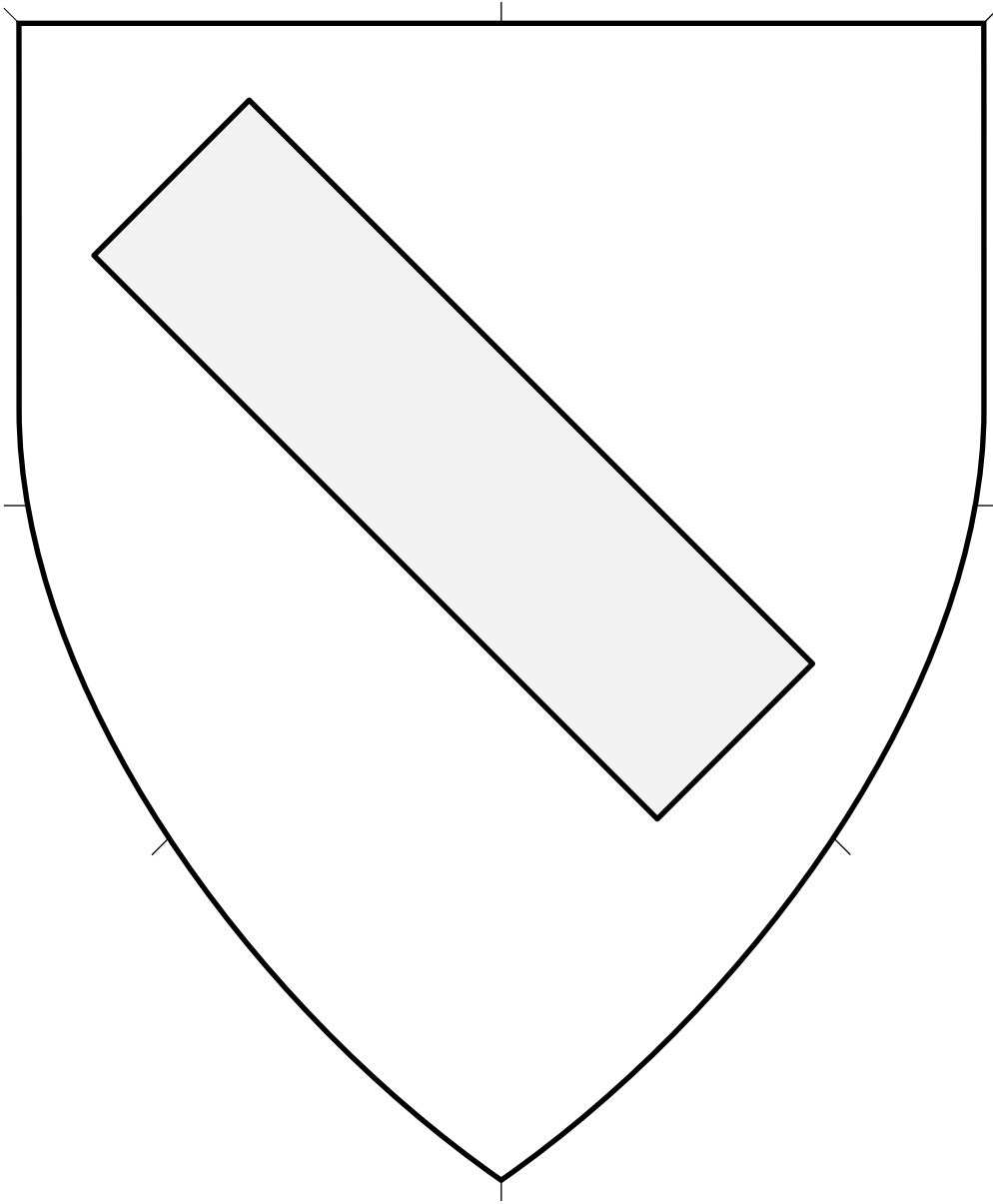

Couped ordinary. A bend couped.

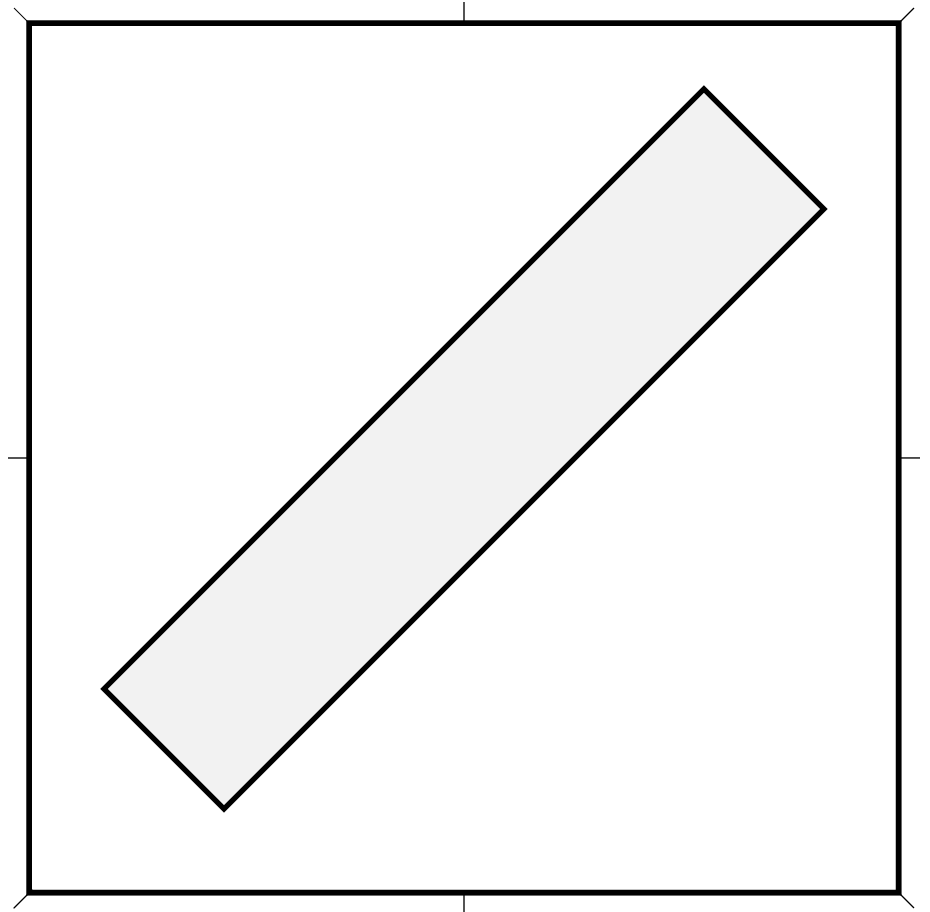
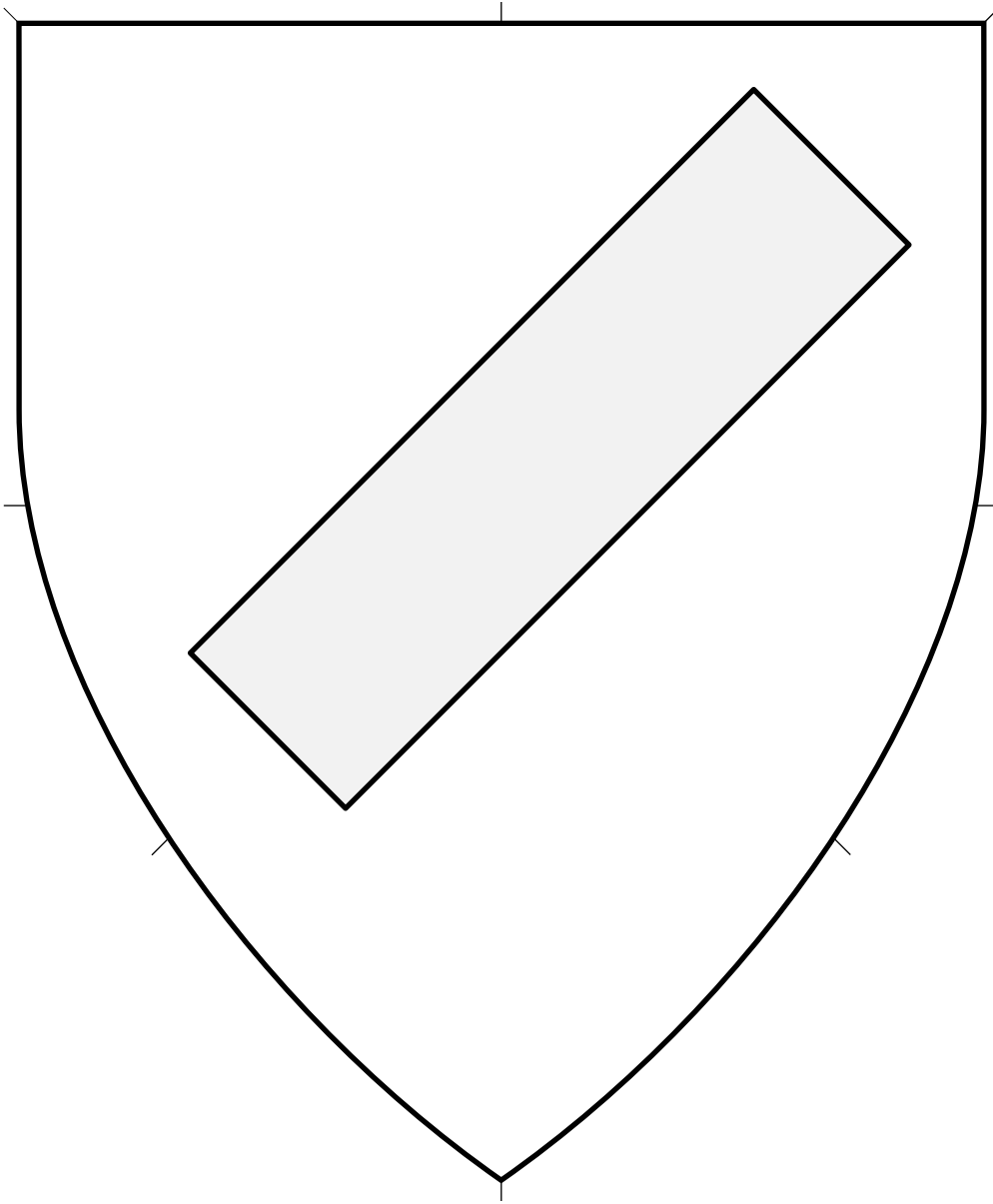

Couped ordinary. A bend sinister couped.

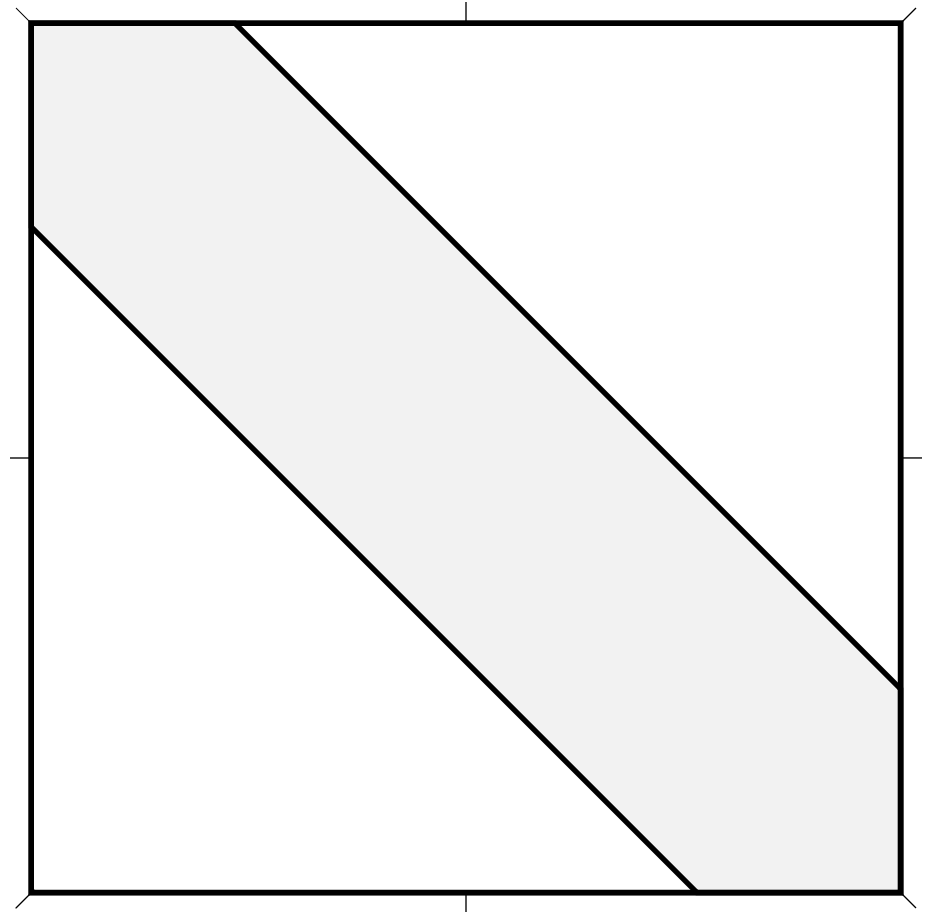
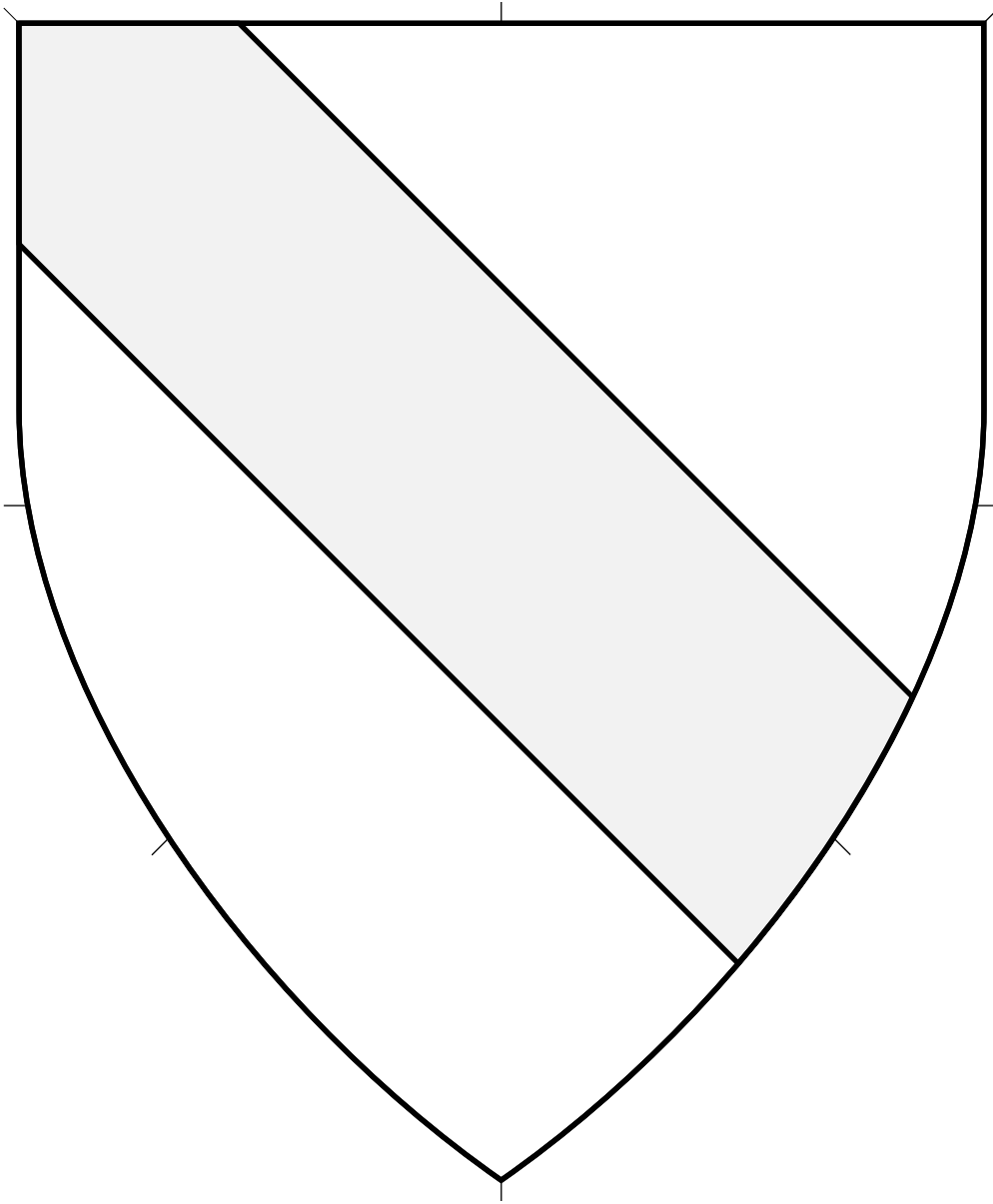

Central ordinary. The width may be a third of the width of the device or a bit narrower.
This is a wider bend, suitable for bearing a charge.

Bend (1) 4.50

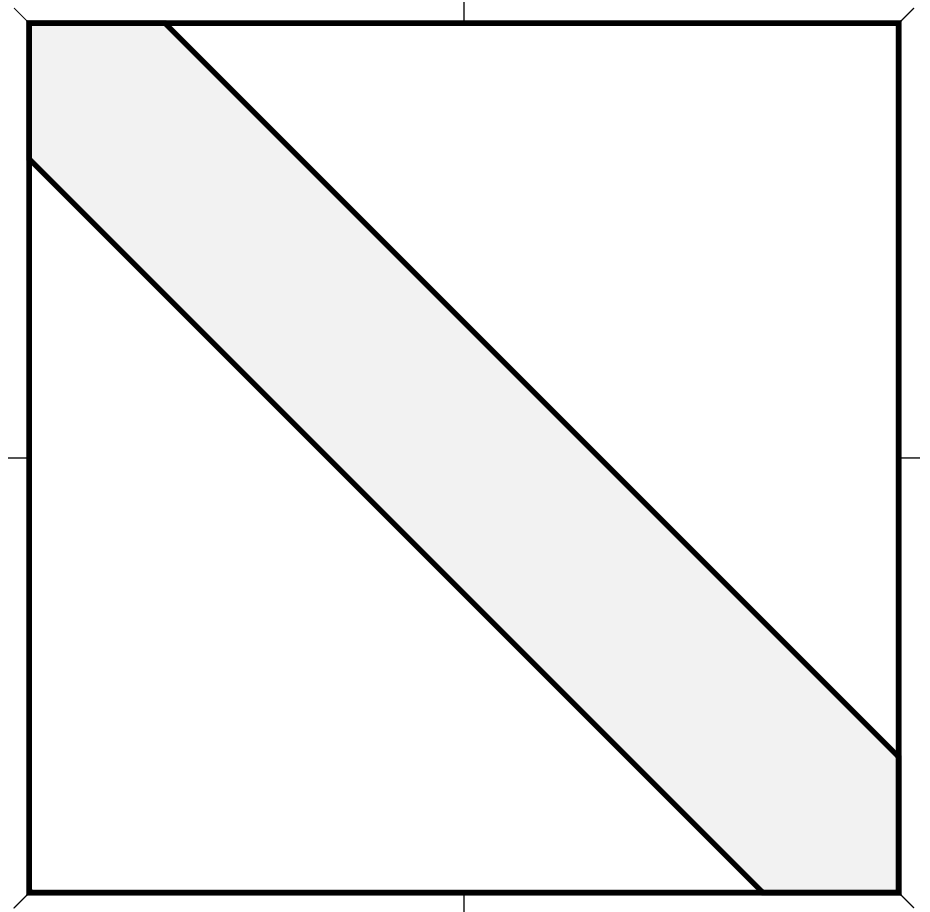
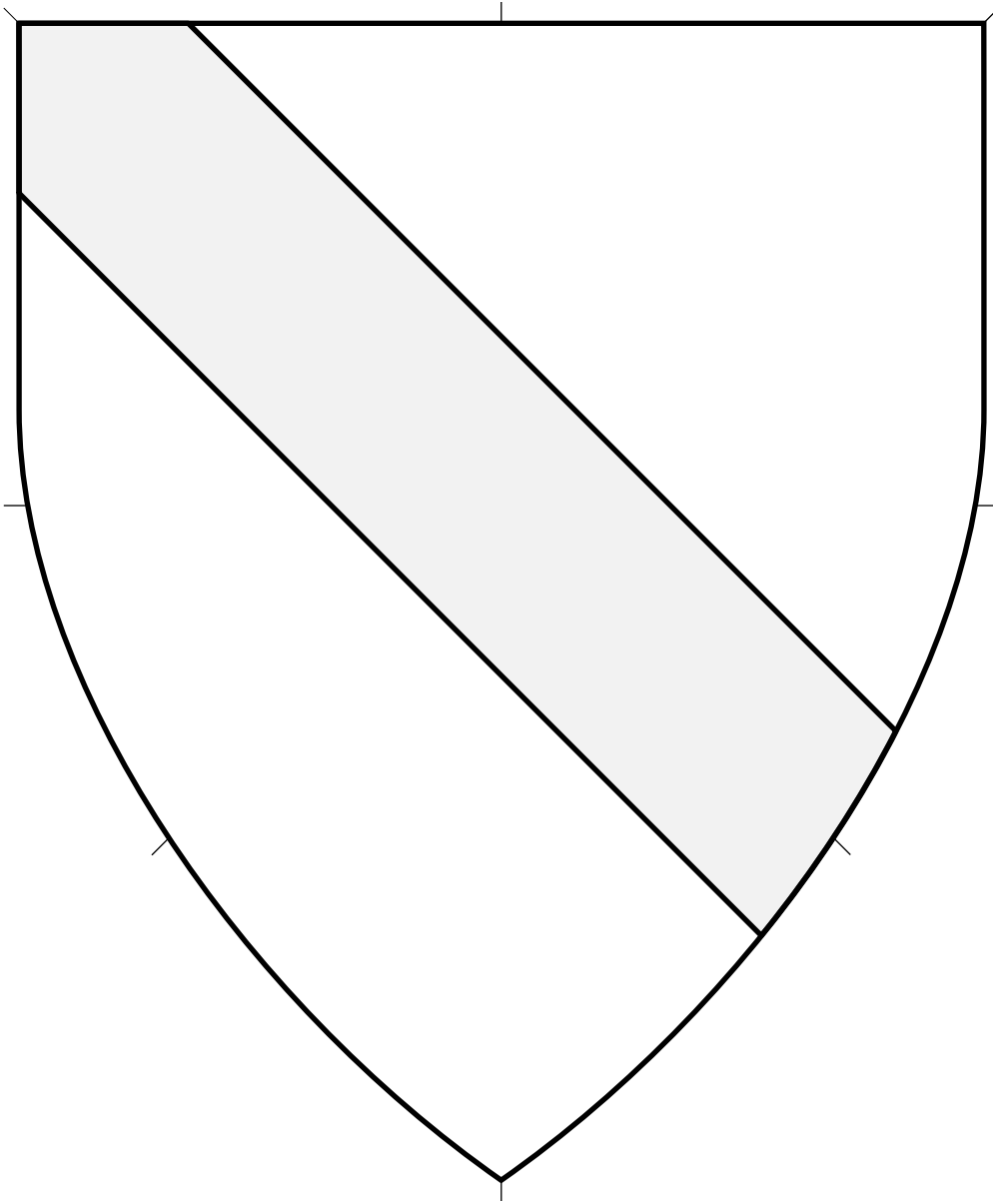

Central ordinary. The width may be a third of the width of the device or a bit narrower.
This is a mid-sized bend.

Bend (2) • 4.51

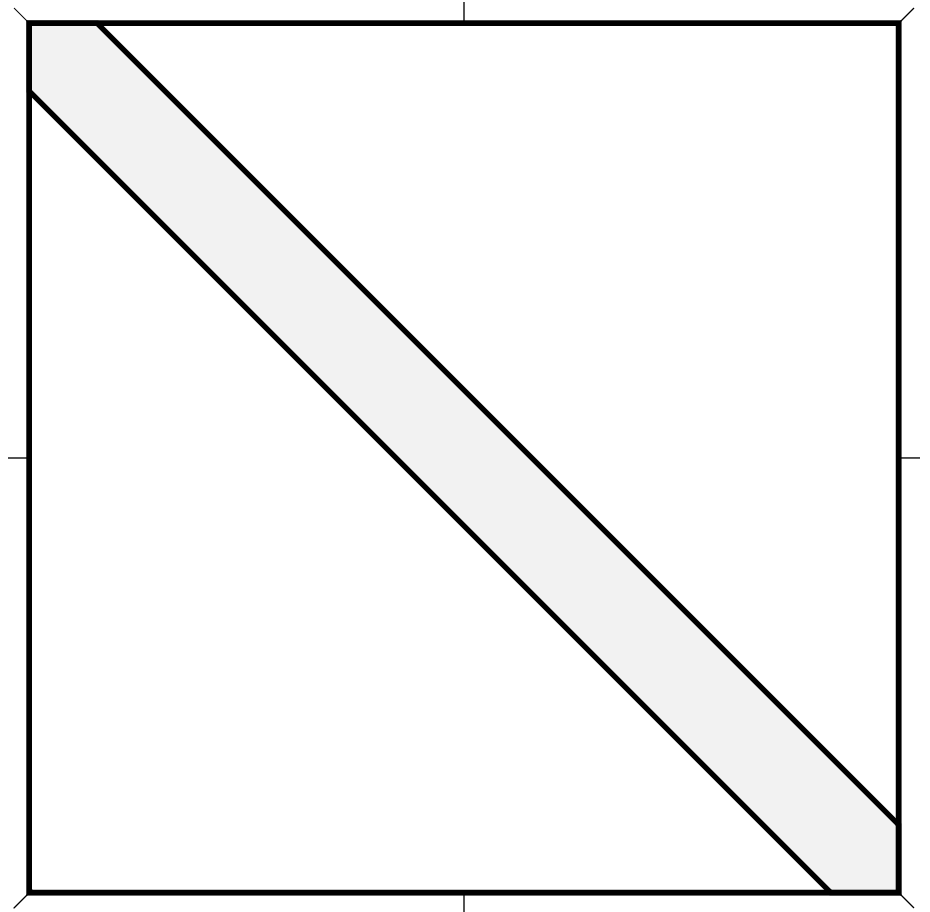
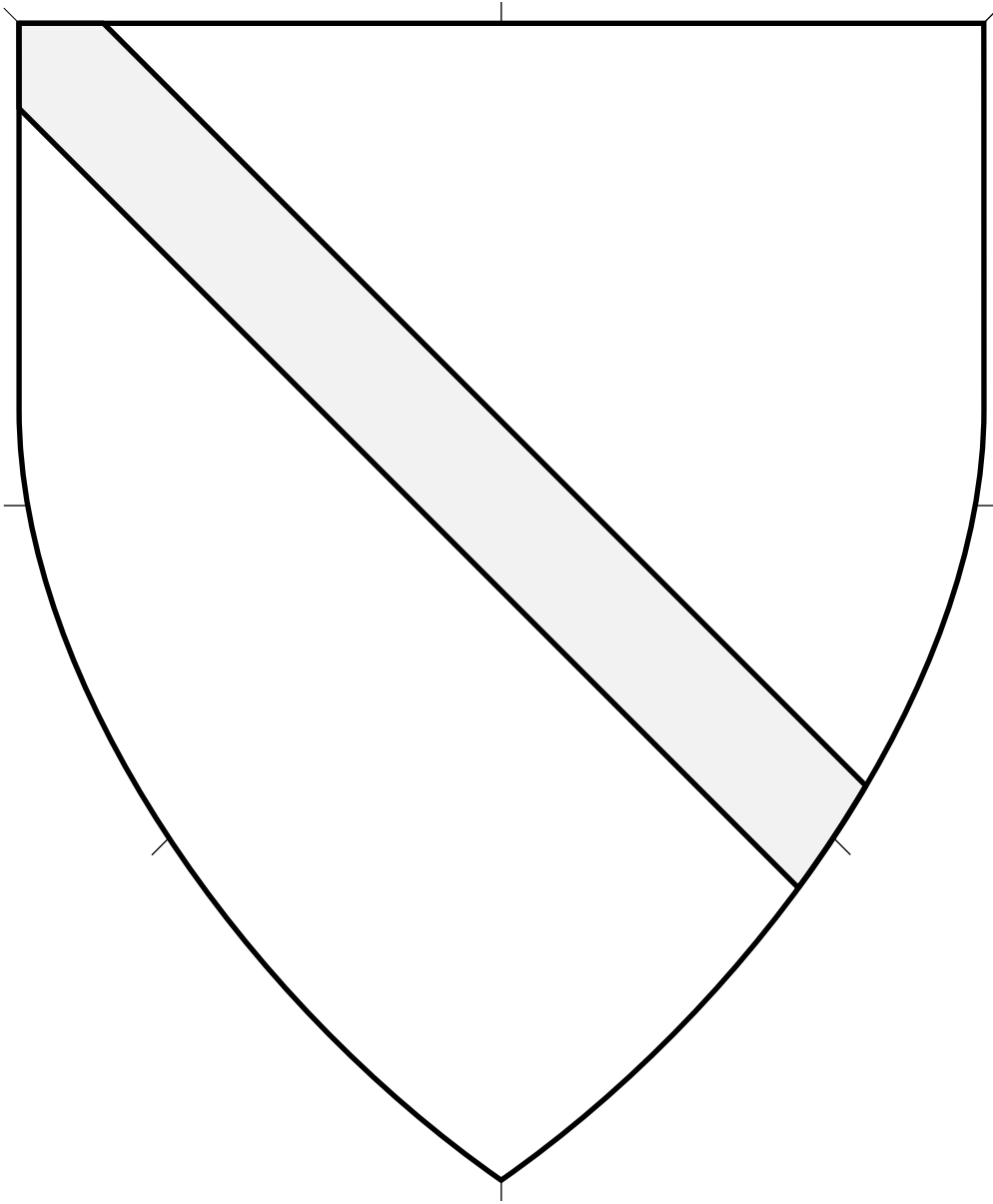

Central ordinary. The width may be a third of the width of the device or a bit narrower.
This is a thin bend.

Bend (3) 4.52

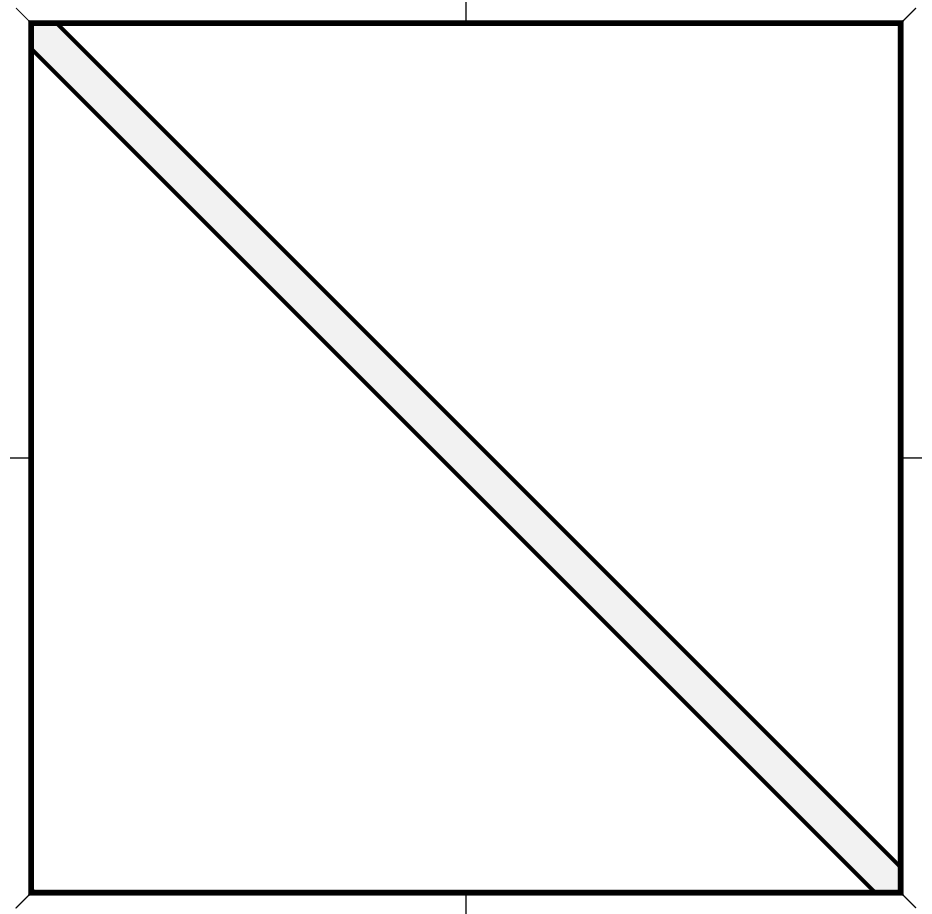
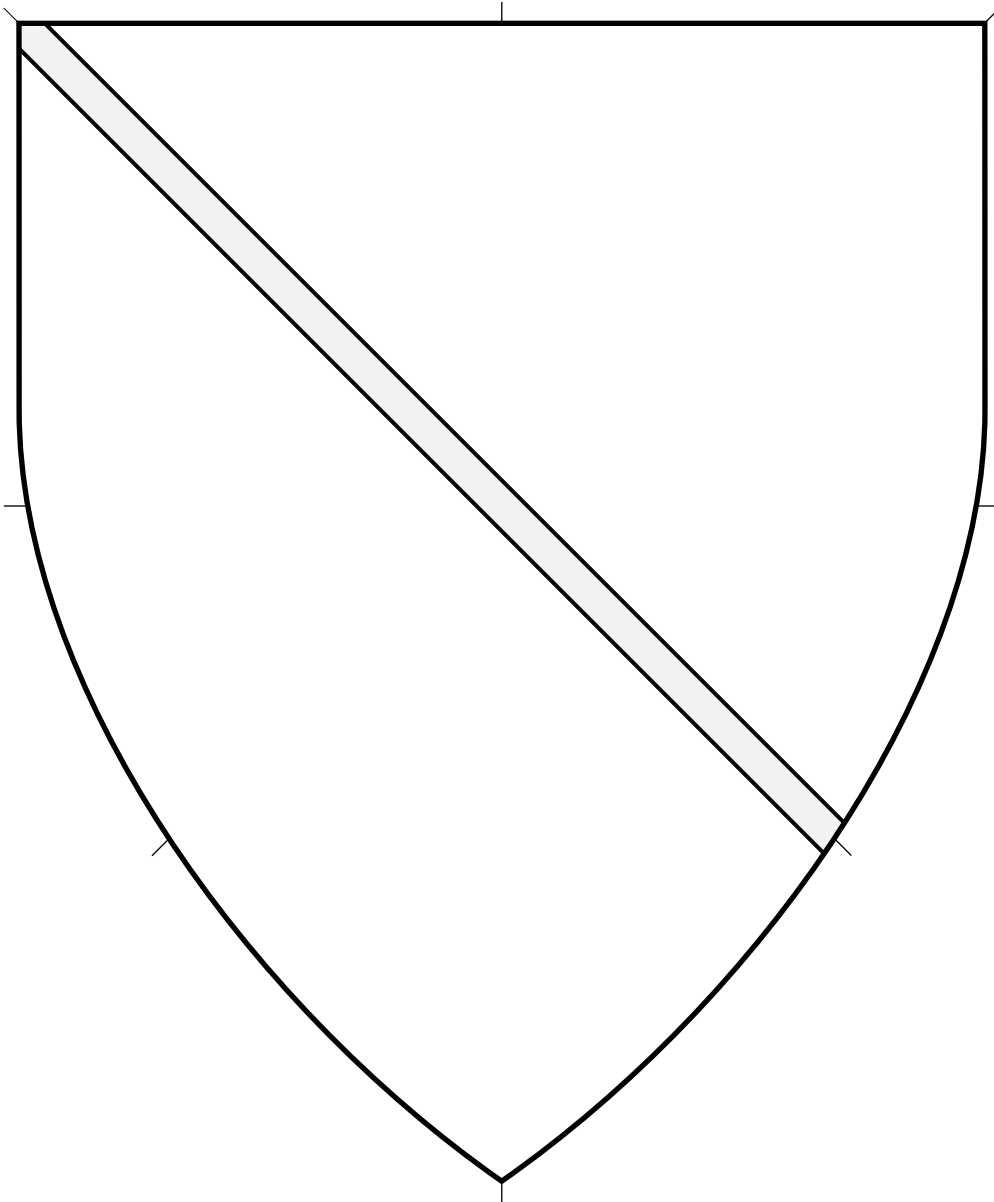

Central ordinary. The width may be a third of the width of the device or a bit narrower.

This type of very-narrow bend is most-often seen as an overall cadency mark.

Source: Commonplace Book of Heraldry. (Folio 29r.)

Artist: Jean Faucket. Adapted by Mathghamhain Ua Ruadháin.

Bend (4) 4.53

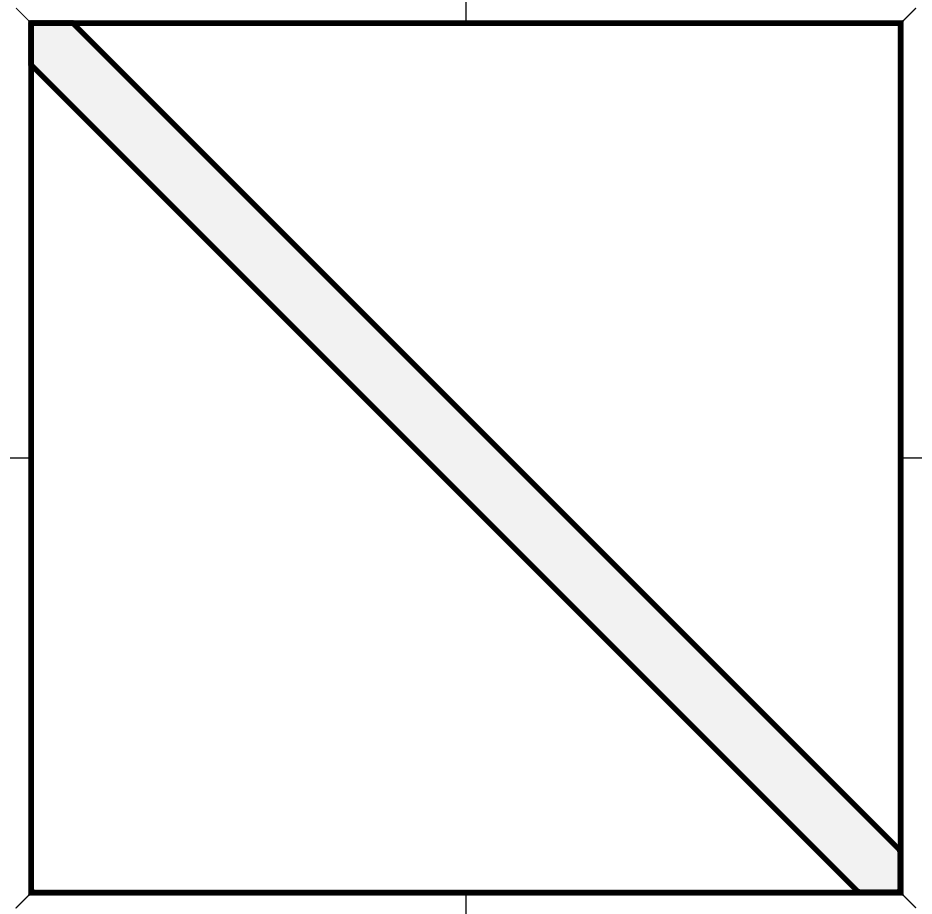
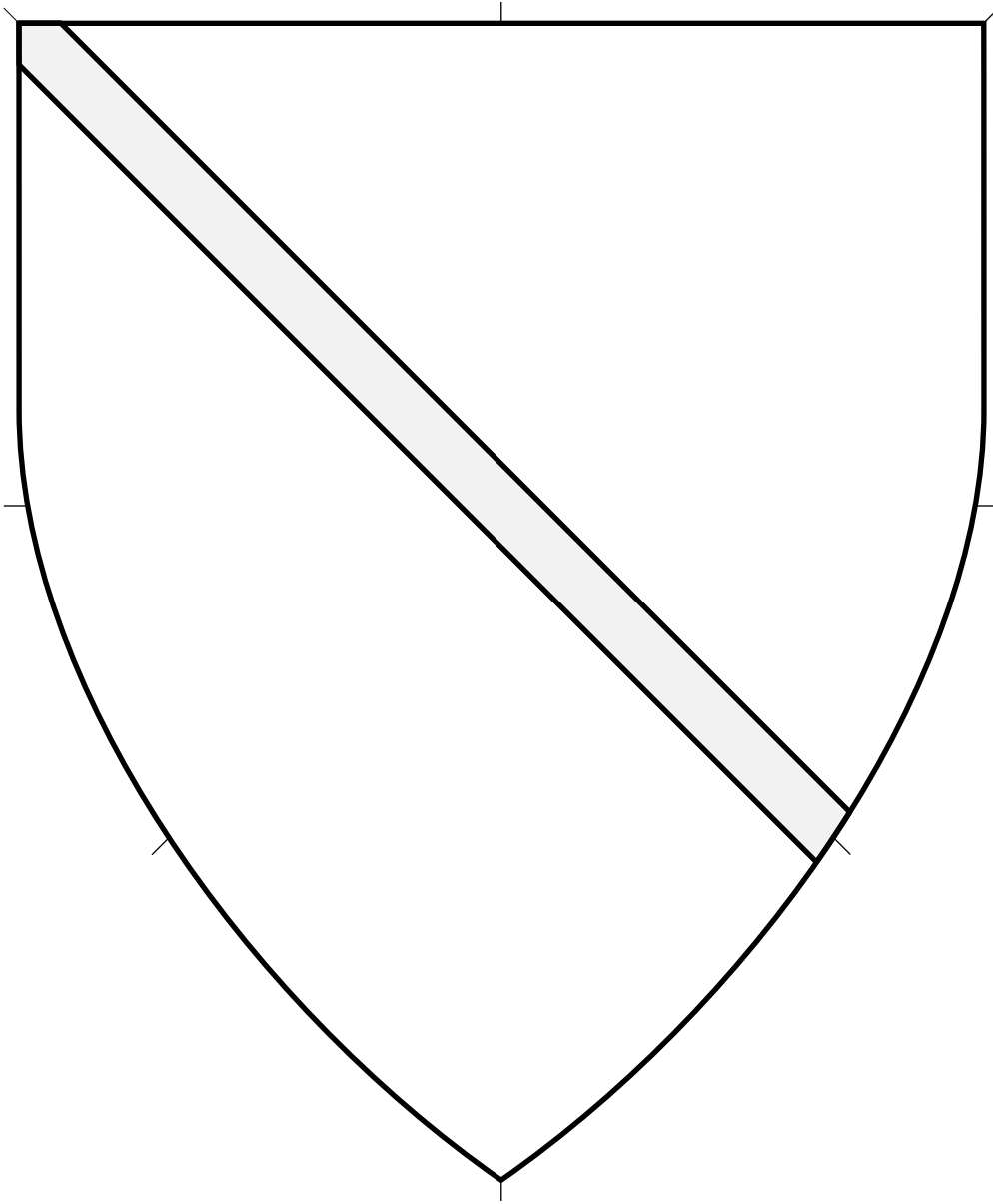

Central ordinary. The width may be a third of the width of the device or a bit narrower.

This type of very-narrow bend is most-often seen as an overall cadency mark.

Source: Le Grand Armorial Équestre de la Toison d'Or. Artist unknown.

Bend (5) 4.54

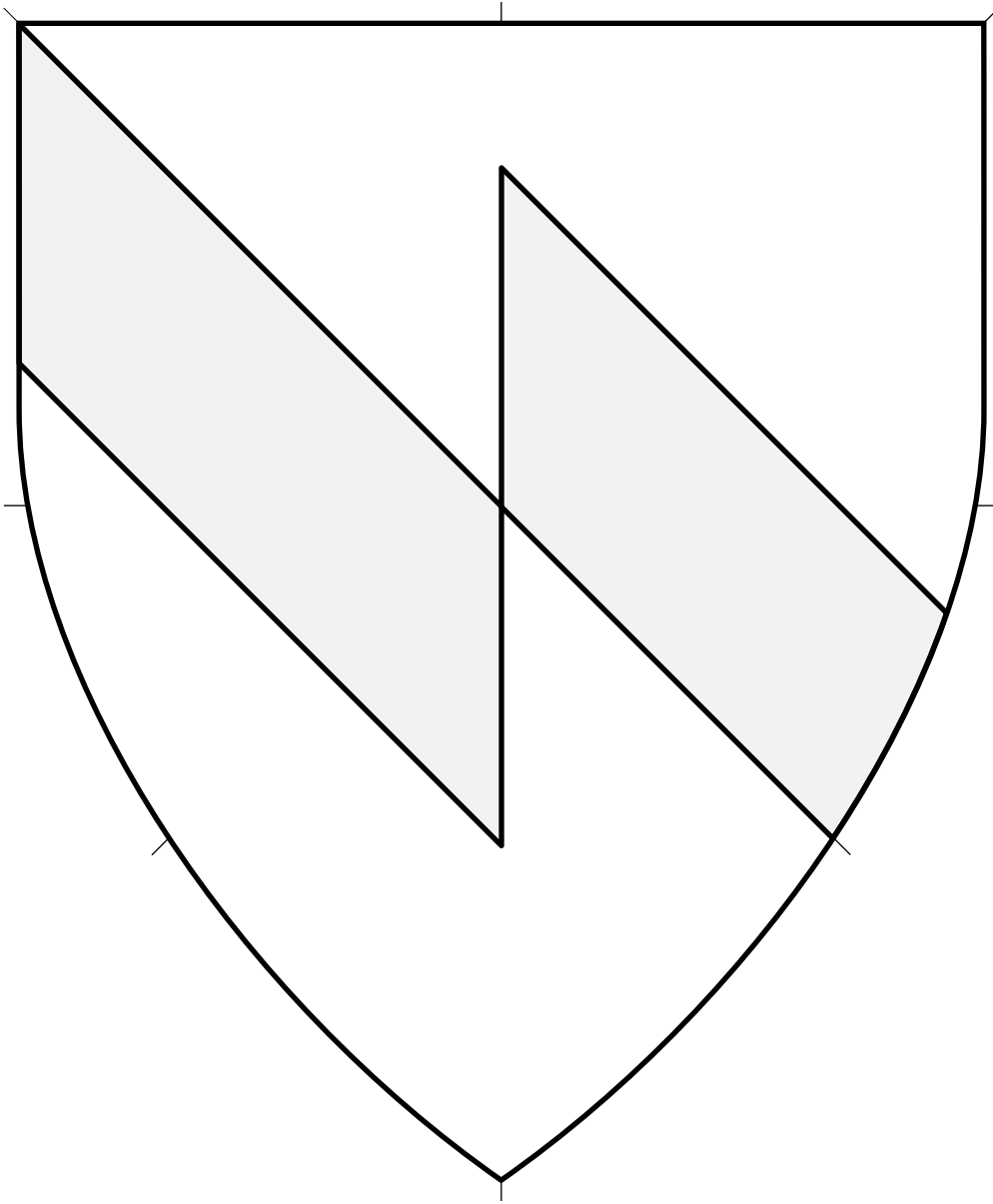

Central ordinary.

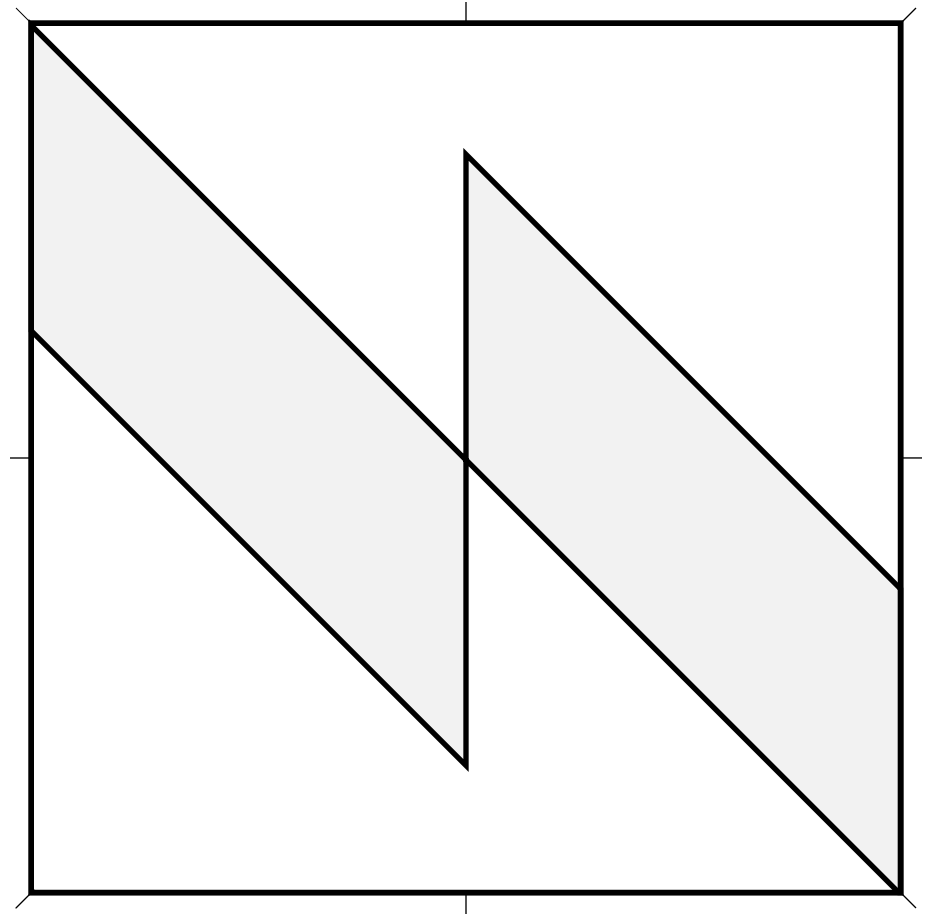

Bend Beville 4.55

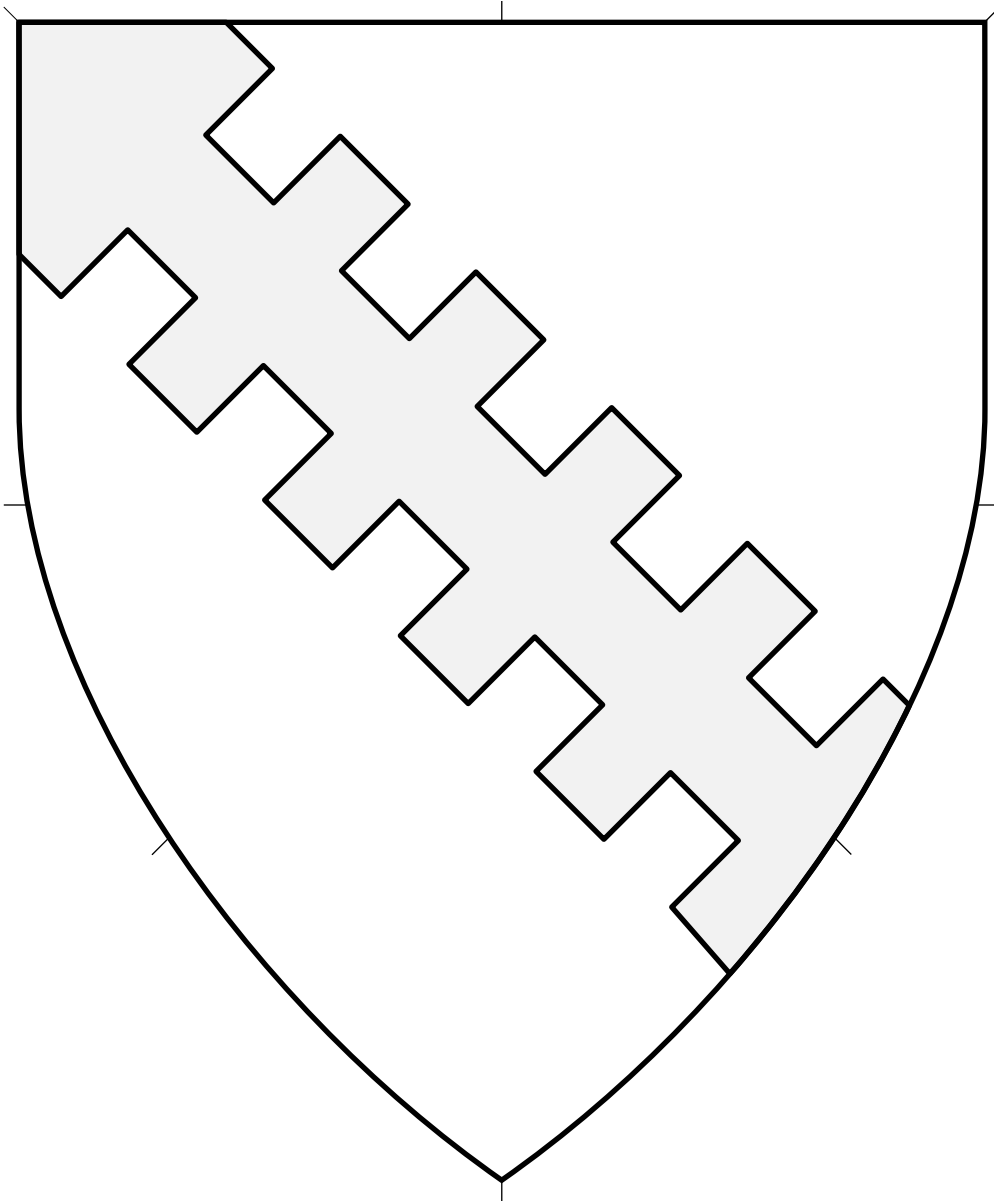

Central ordinary.

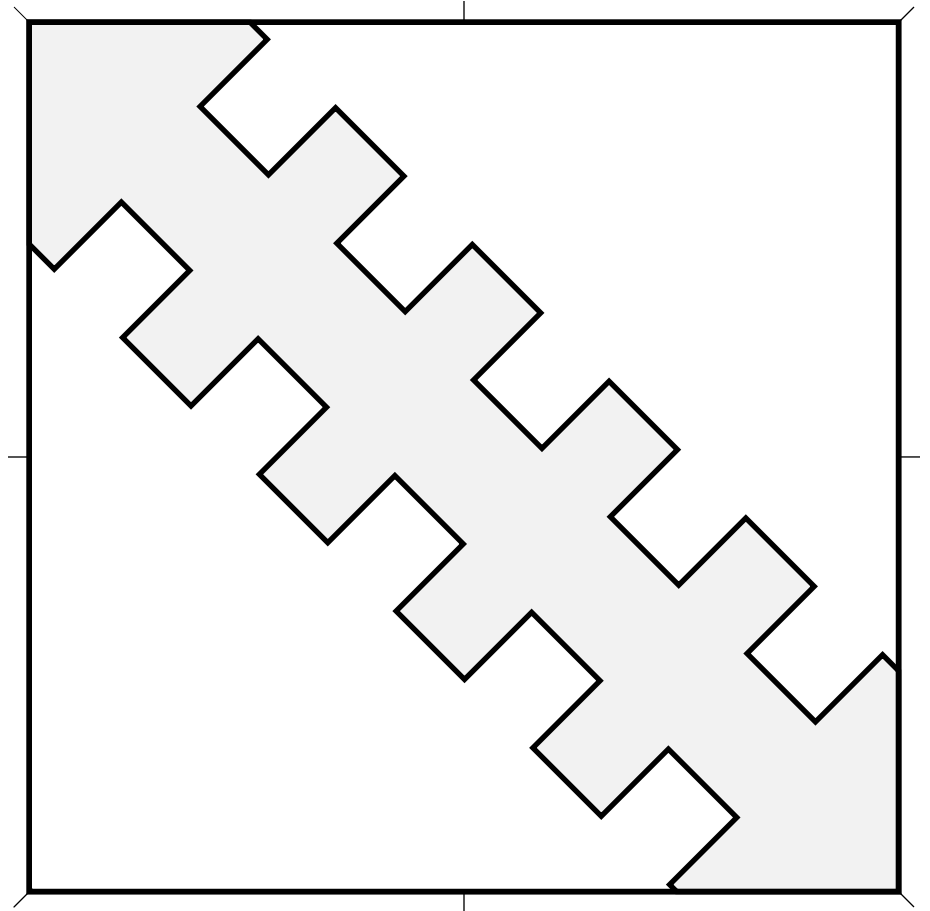

Bend Breasted (1) 4.56

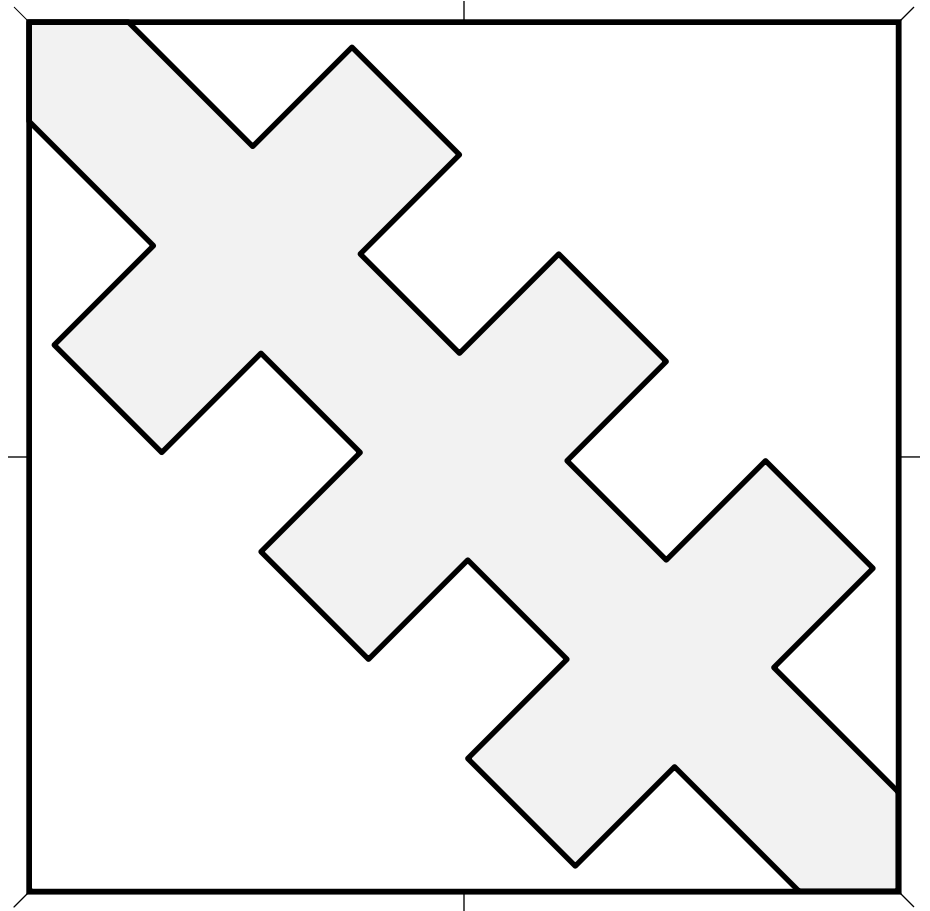
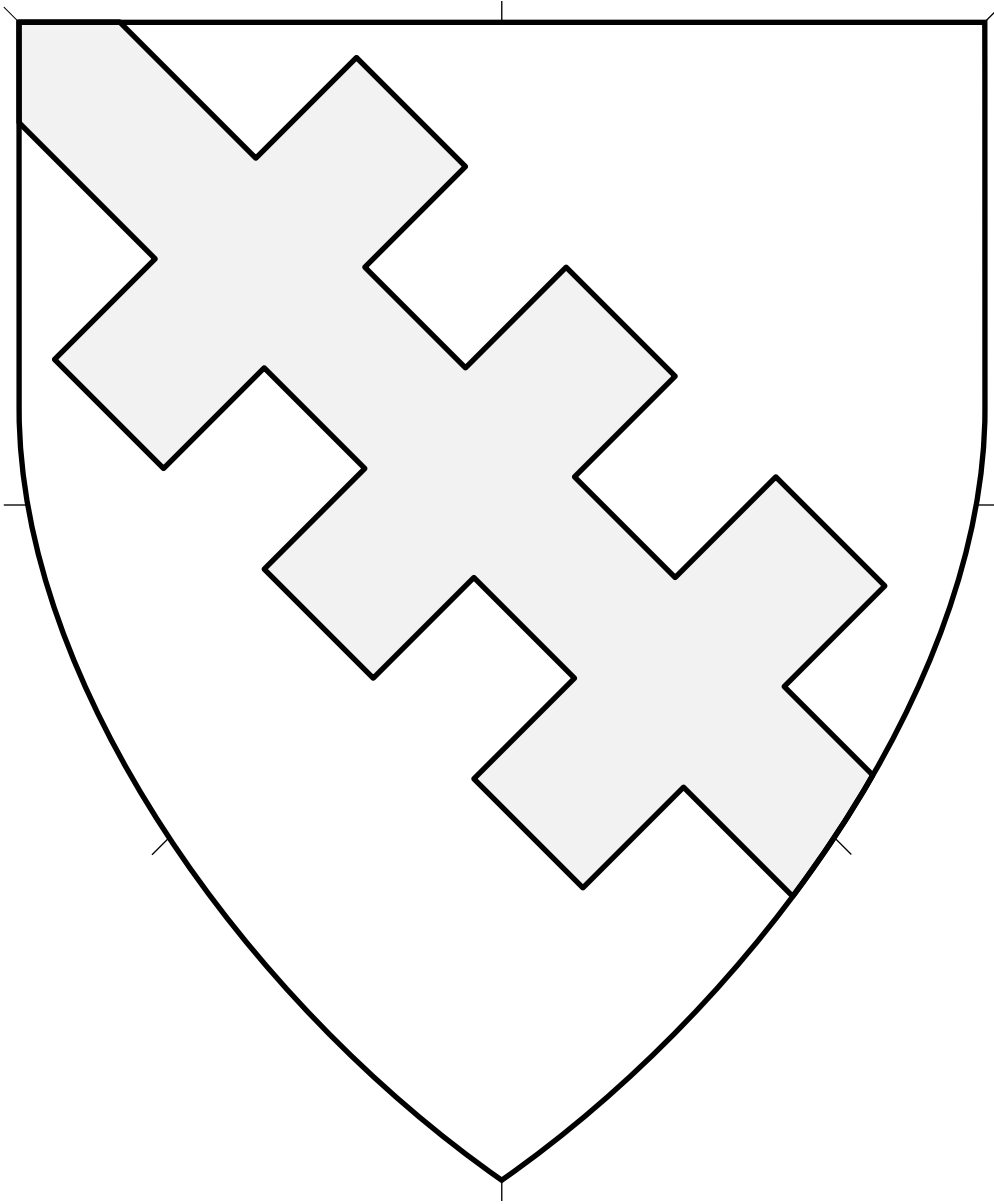

Central ordinary.

Source: Zurich Roll. Artist unknown. (Folio 2r.)

Bend Breasted (2) 4.57

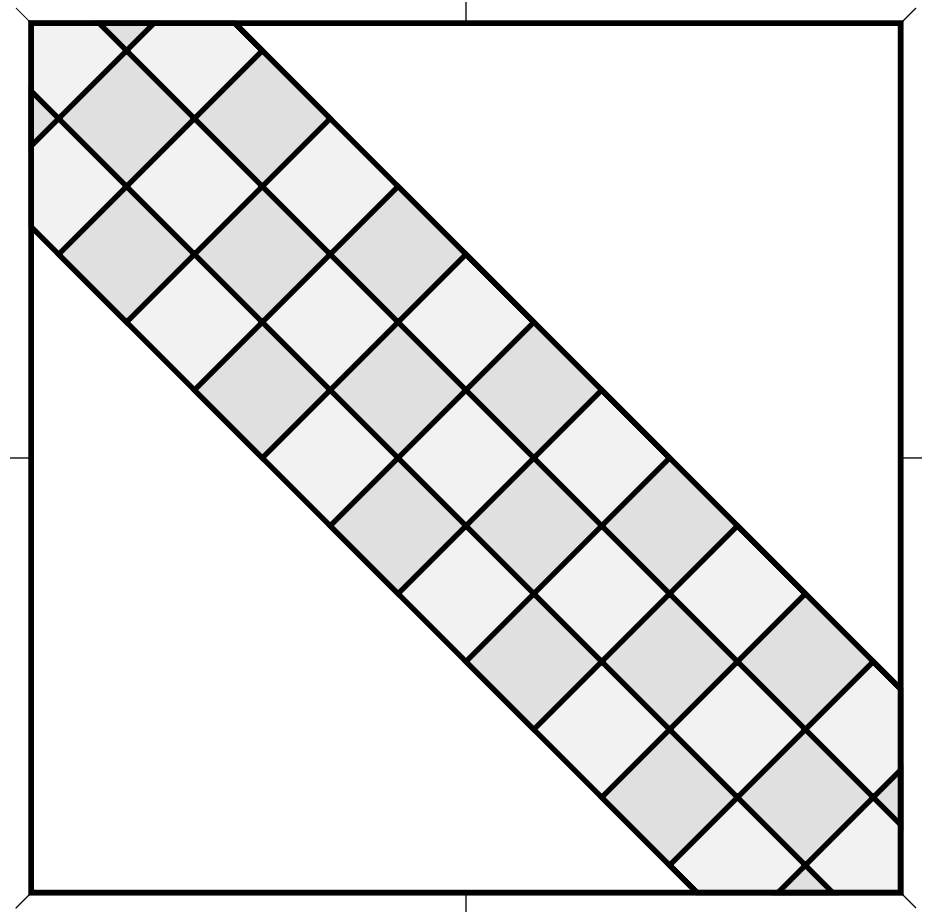
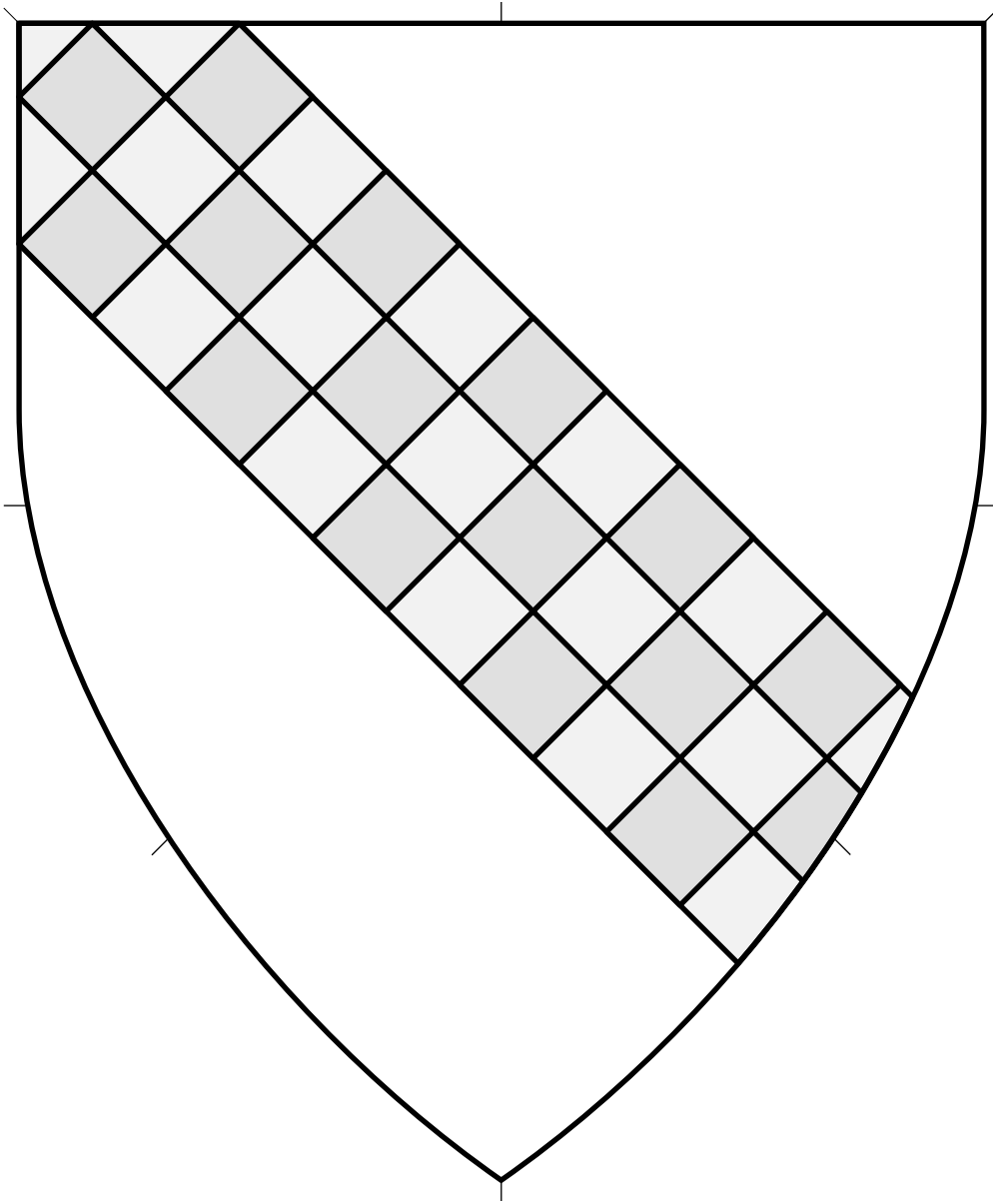

Central ordinary. Two contrasting tinctures.

Bend Checky 4.58

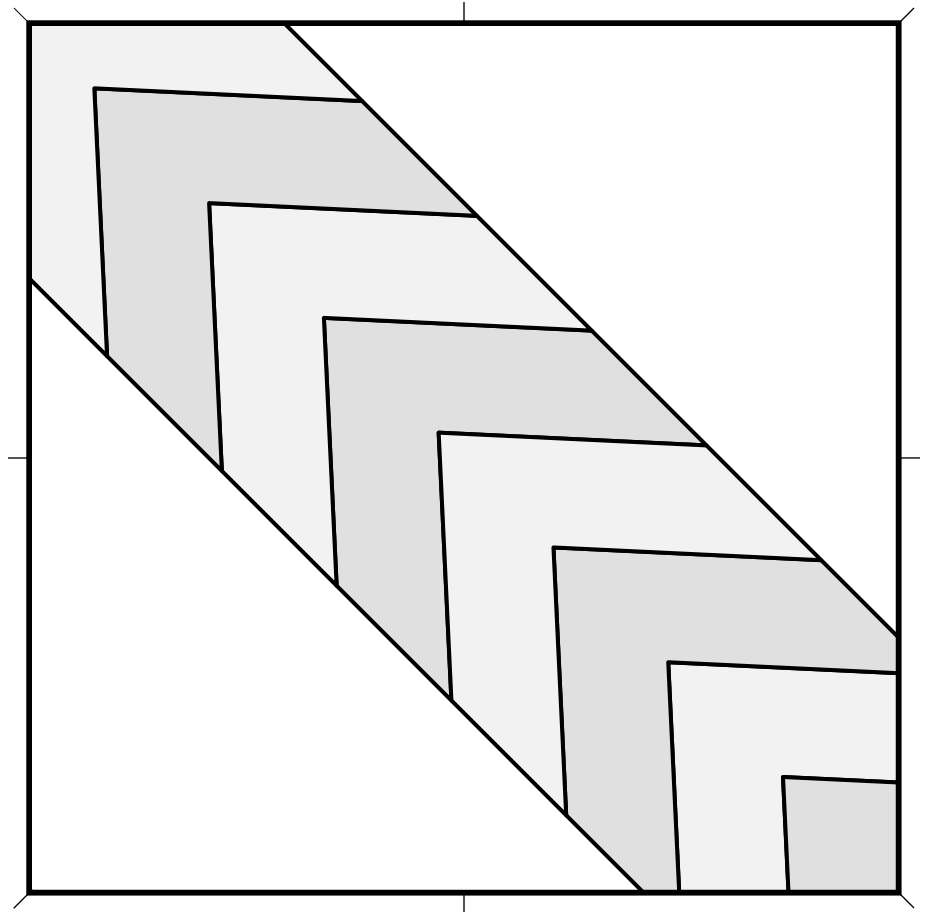
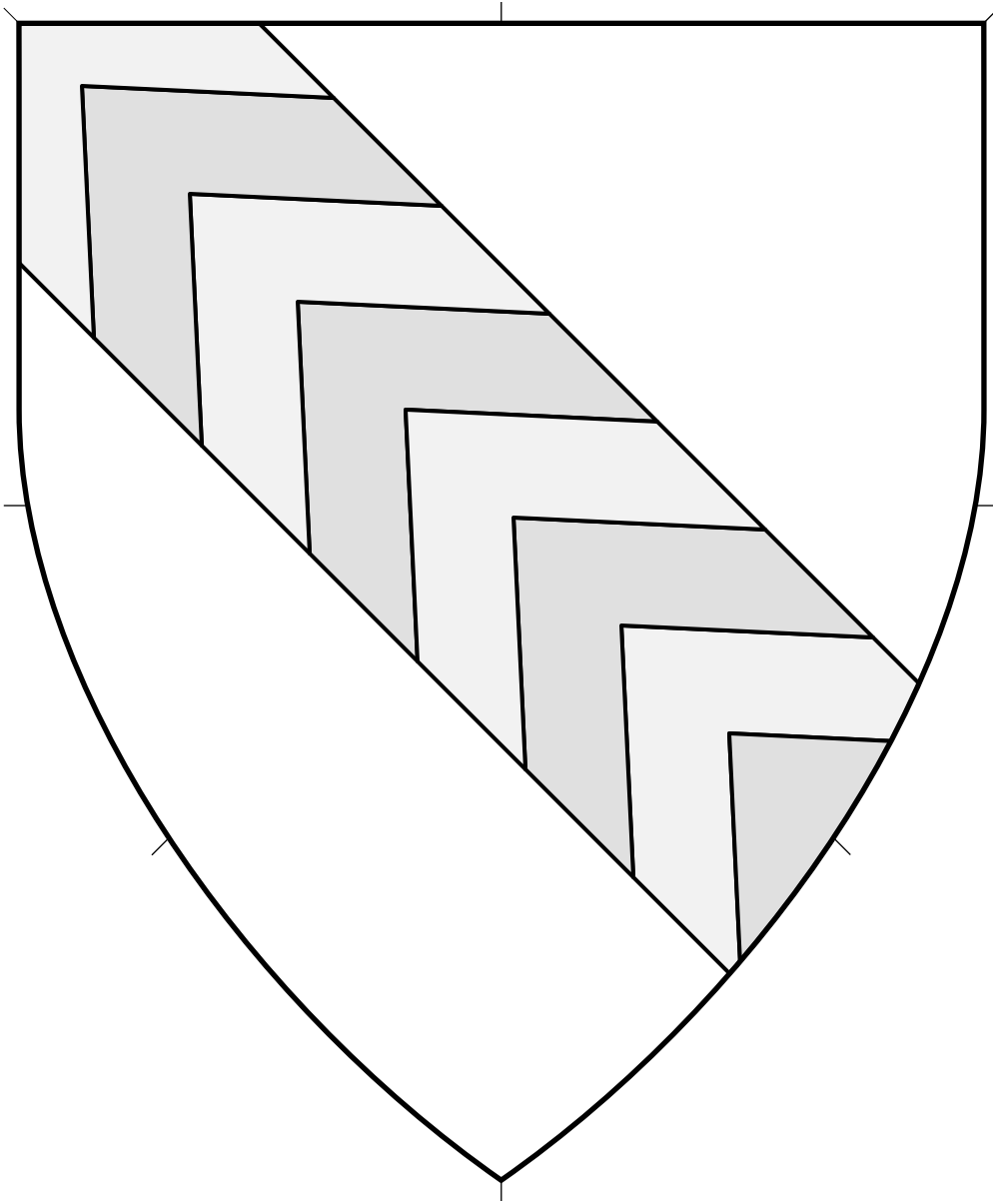

Central ordinary. Two contrasting tinctures.

Source: Insignia Pontificum Romanorum et Cardinalium I.
Artist unknown. (Folio 171r.)

Bend Chevronelly 4.59

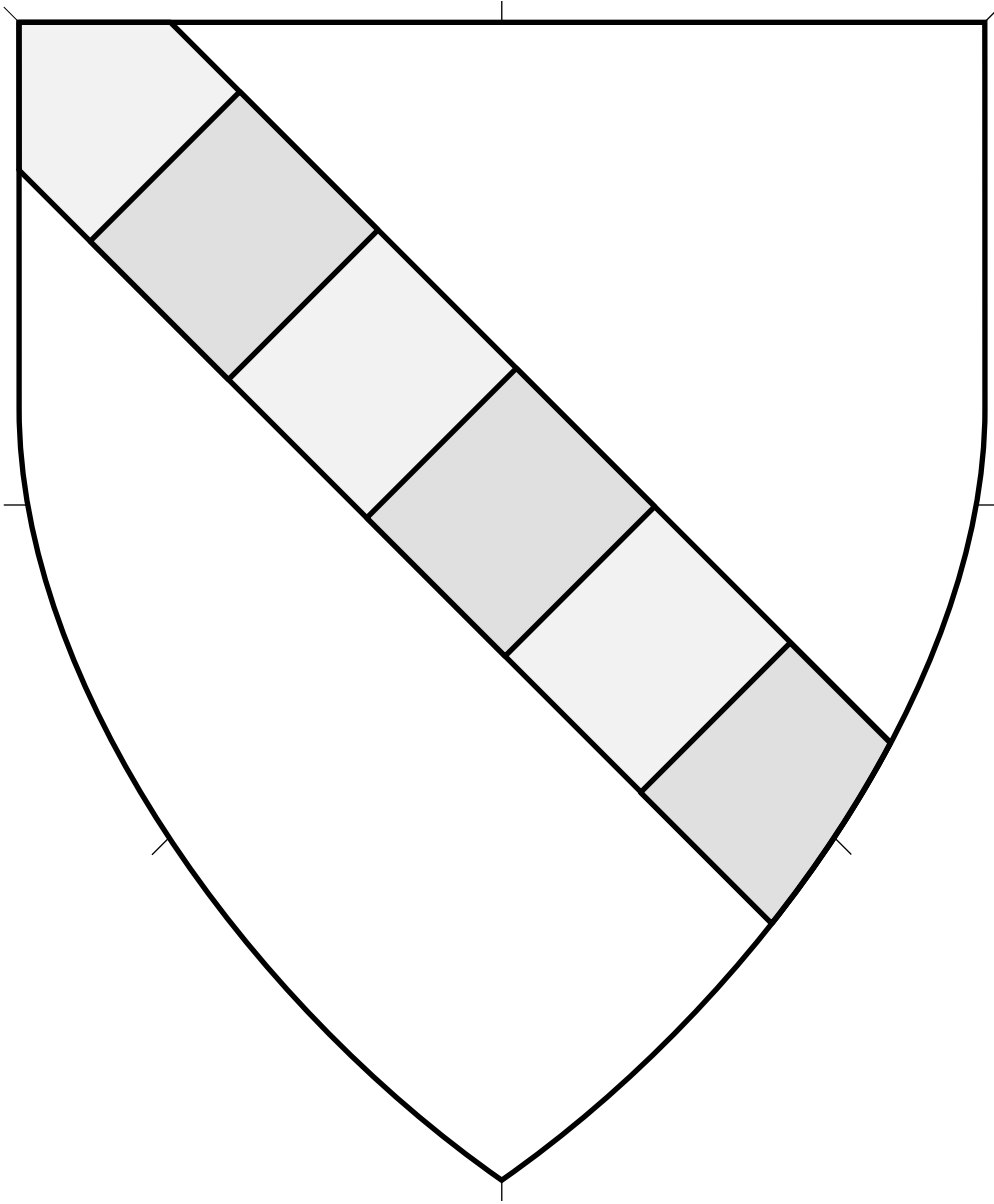

Central ordinary.

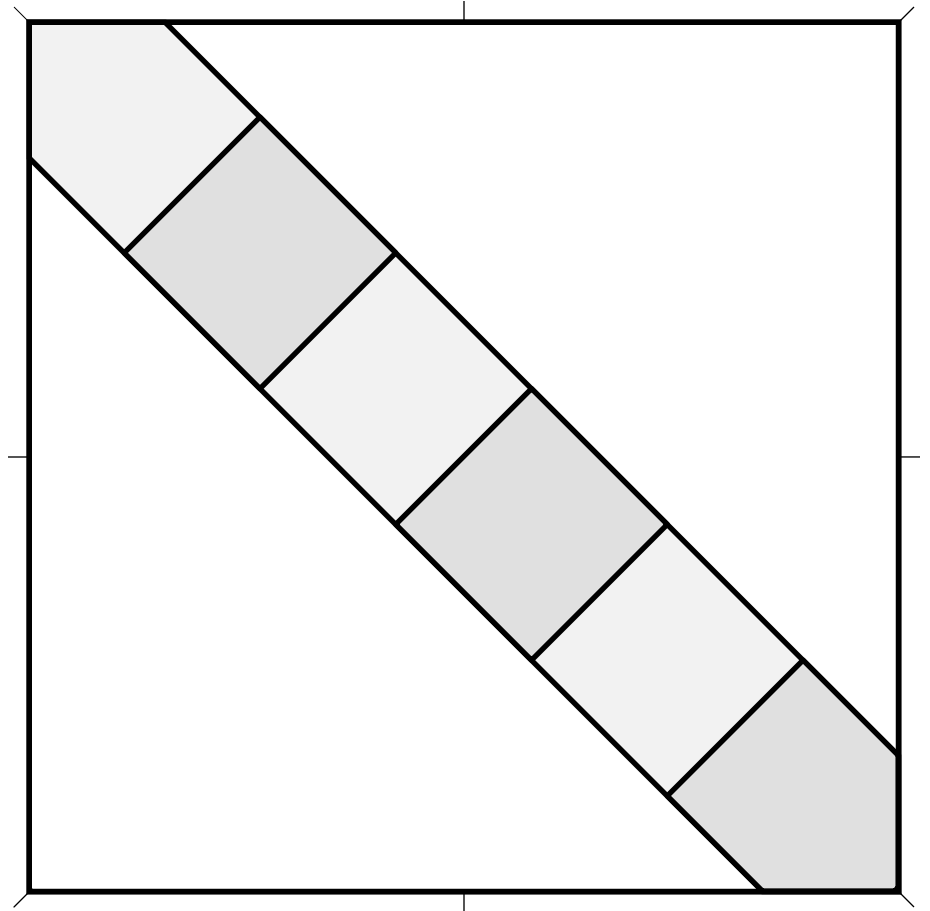

Bend Compony (1) 4.60

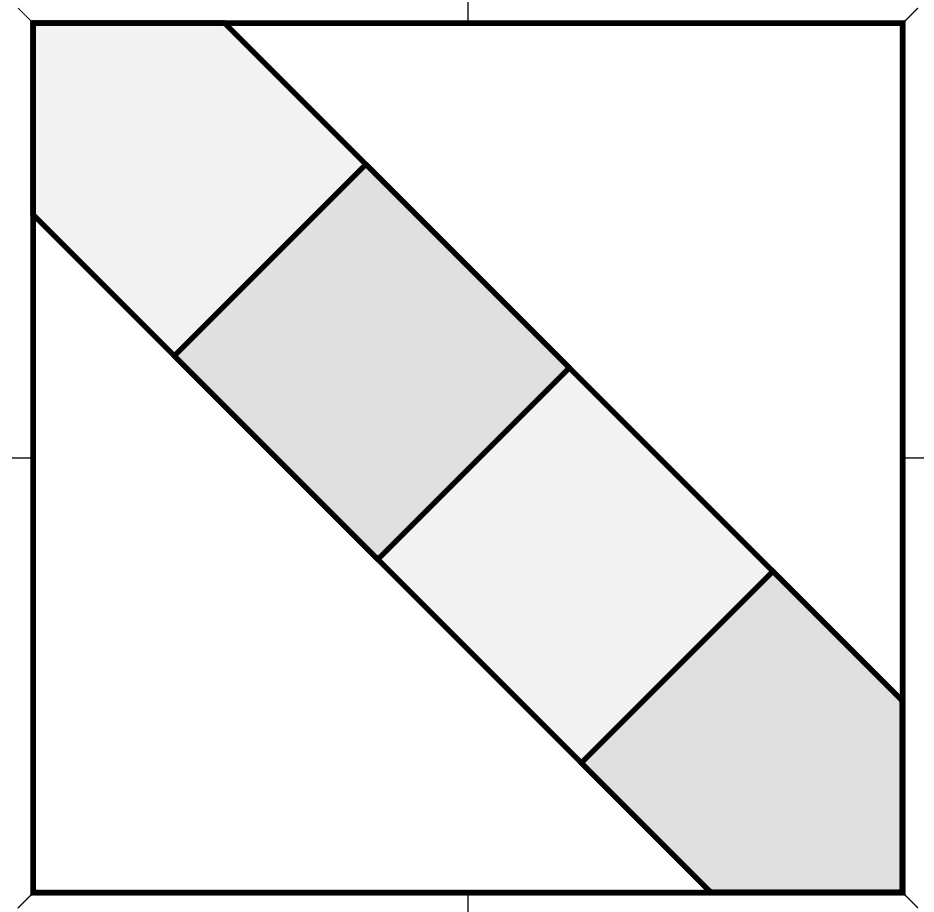
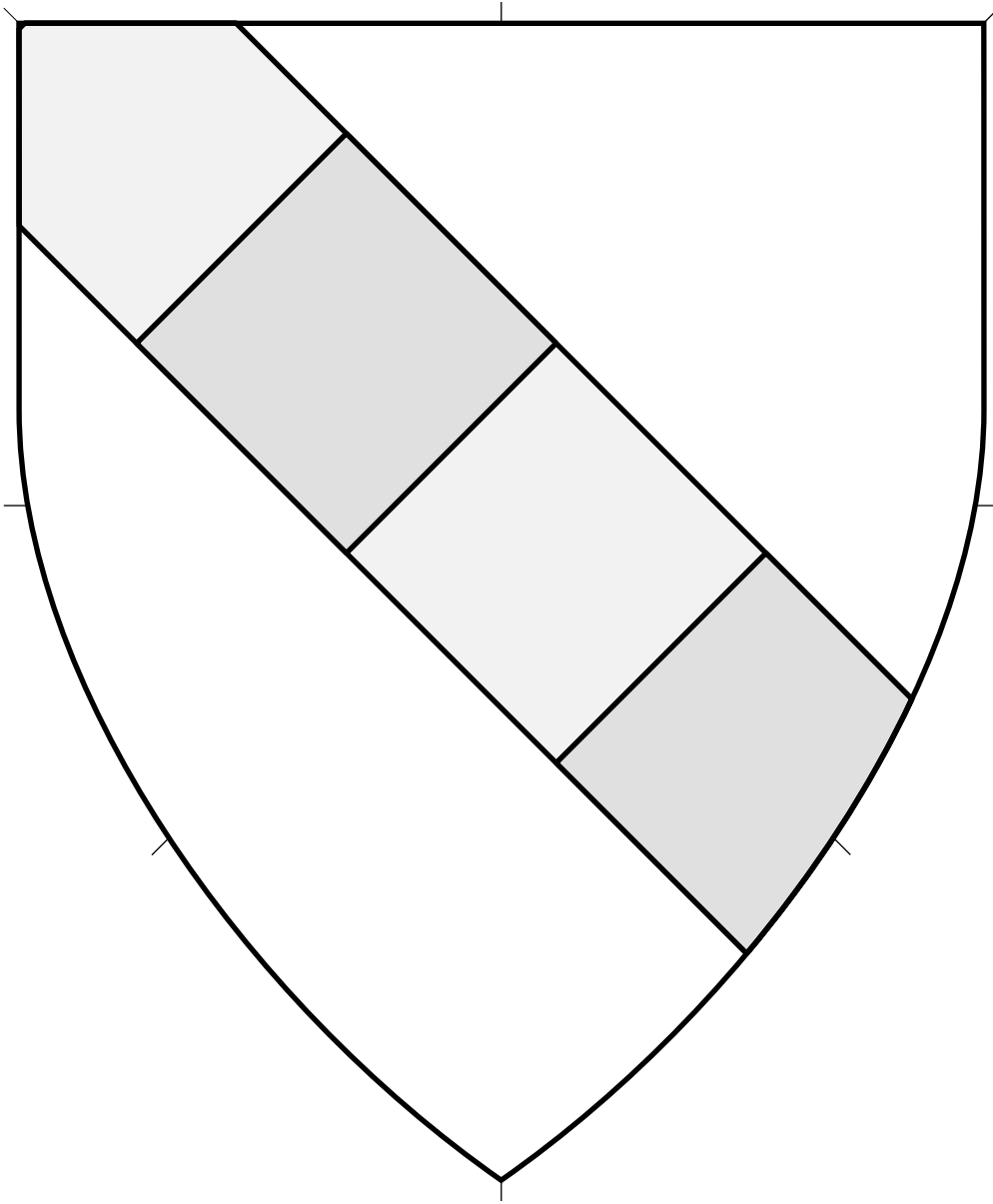

Central ordinary.

Source: BnF MS Allemand 304. Artist unknown. (Page 492.)

Bend Company (2) 4.61

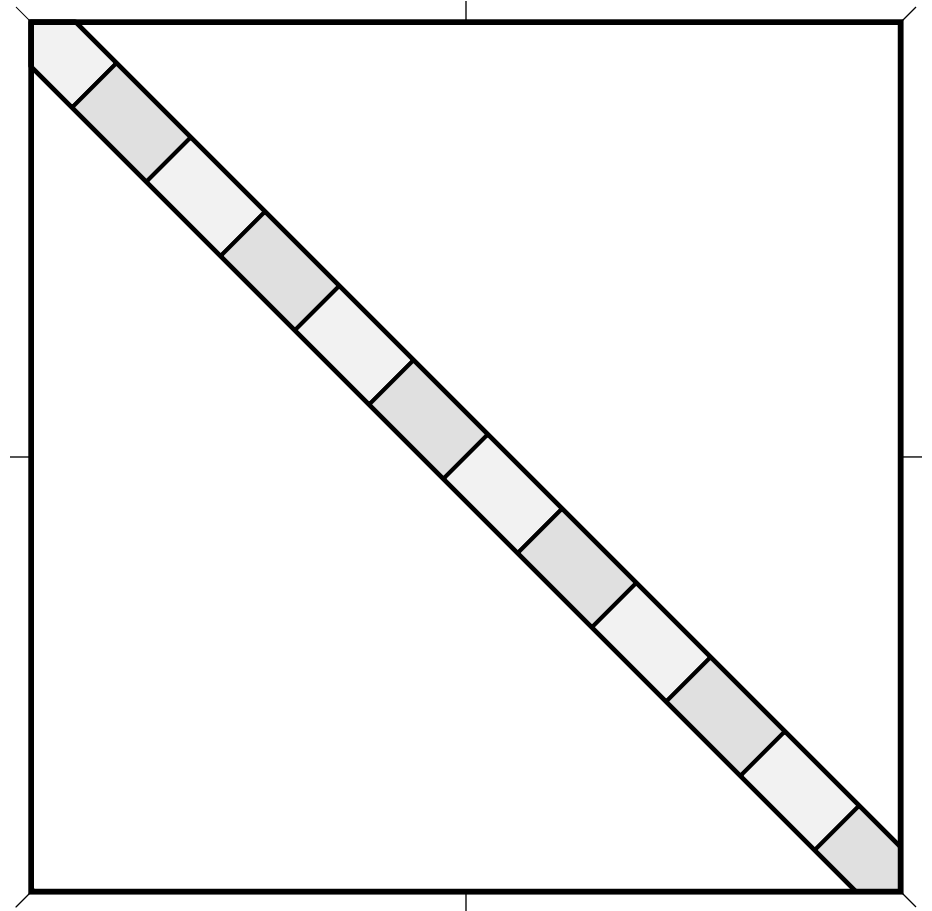
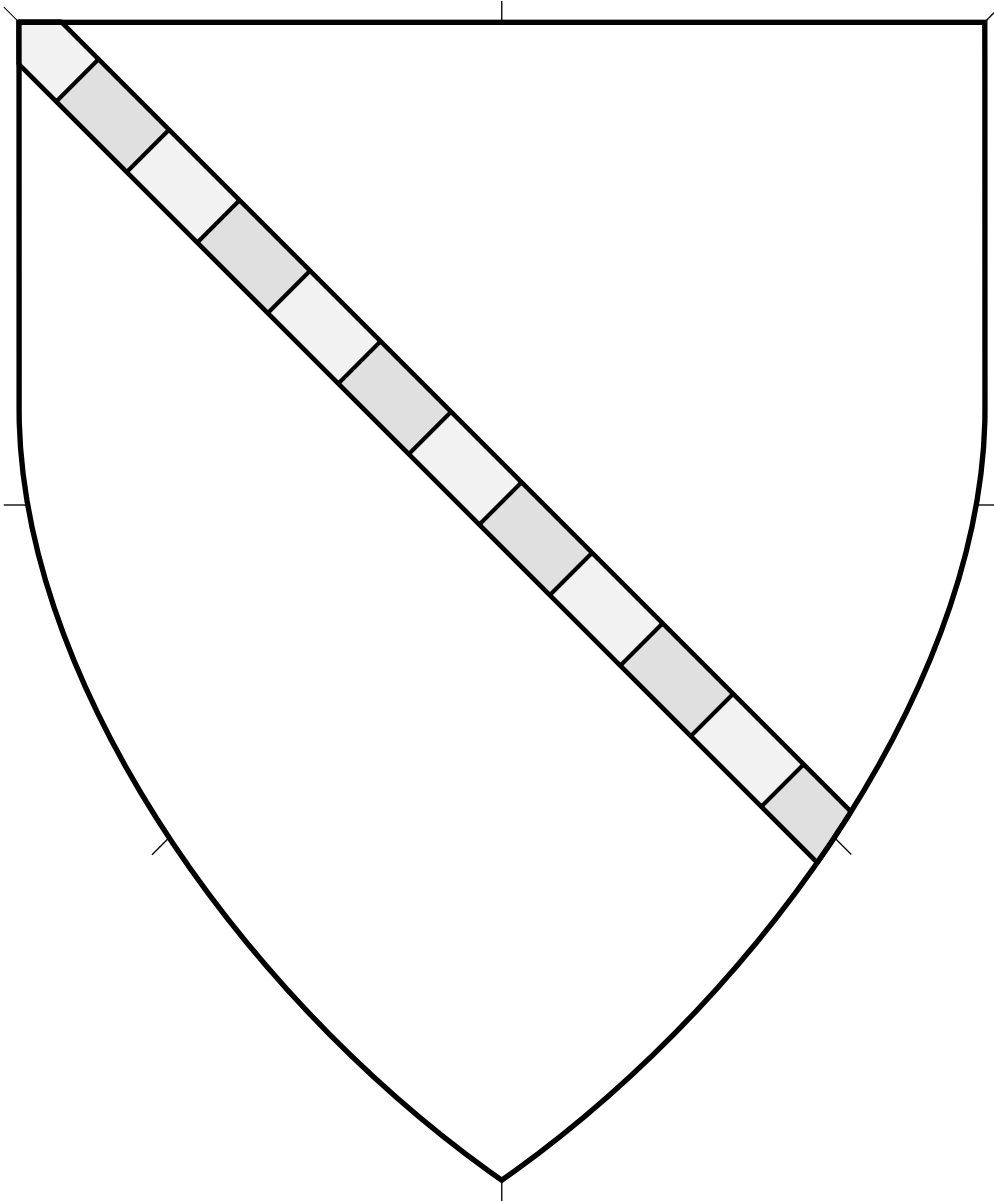

Central ordinary.

This is a very thin bend, as might be used overall for a cadency mark.

Source: Commonplace Book of Heraldry. (Folio 29v.)

Artist: Jean Faucket. Adapted by Mathghamhain Ua Ruadháin.

Bend Compony (3) 4.62

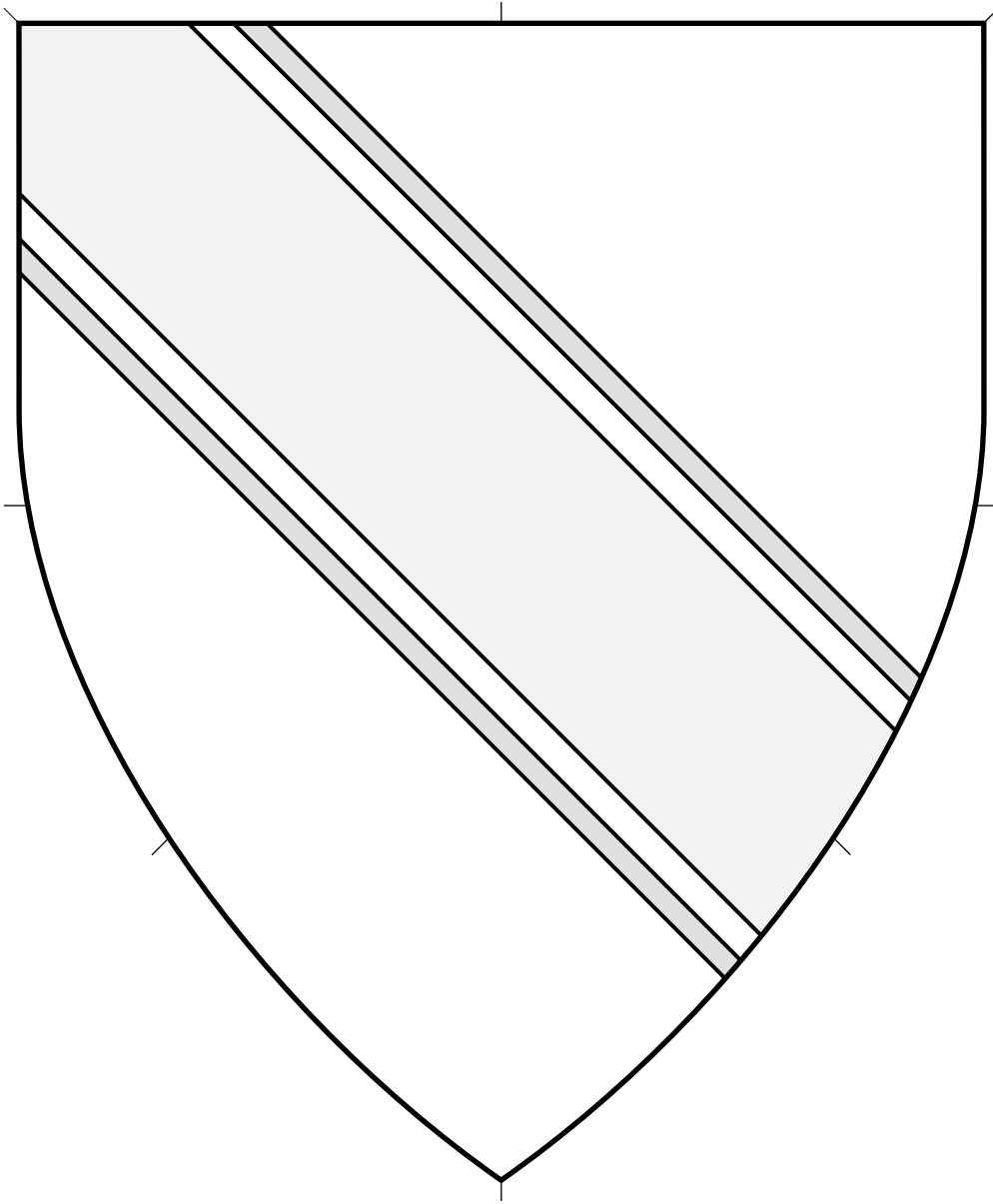

Central ordinary with secondaries.

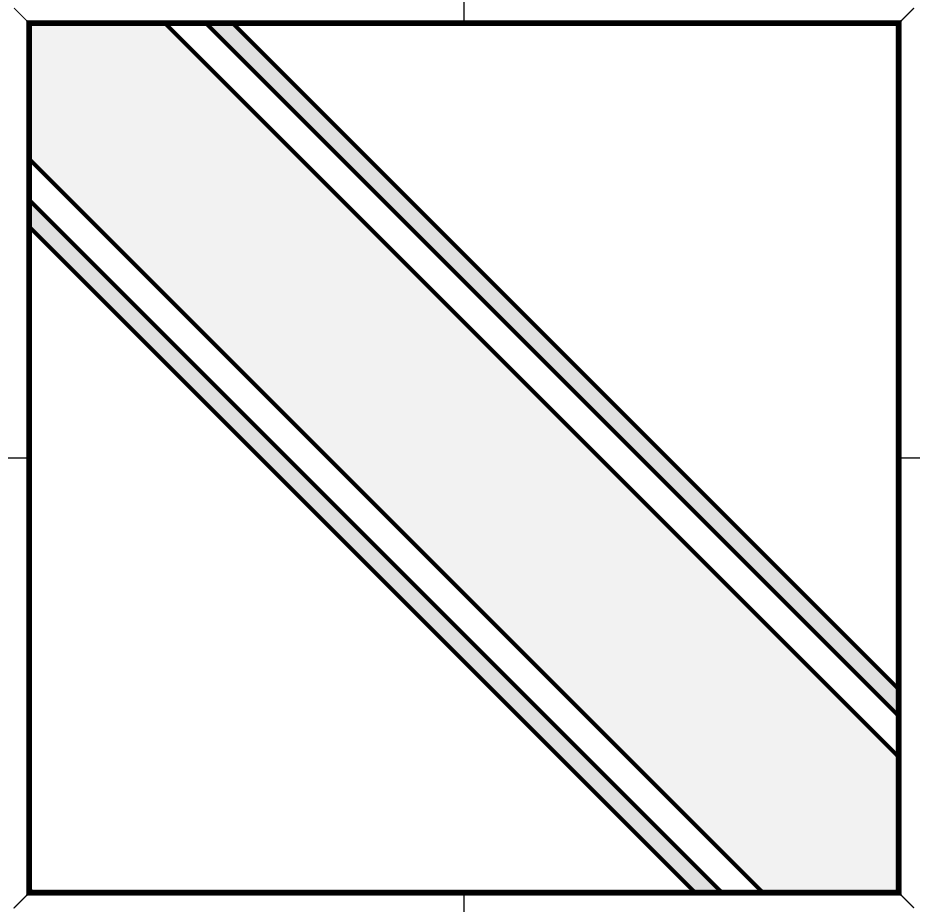

Bend Cotised (1) 4.63

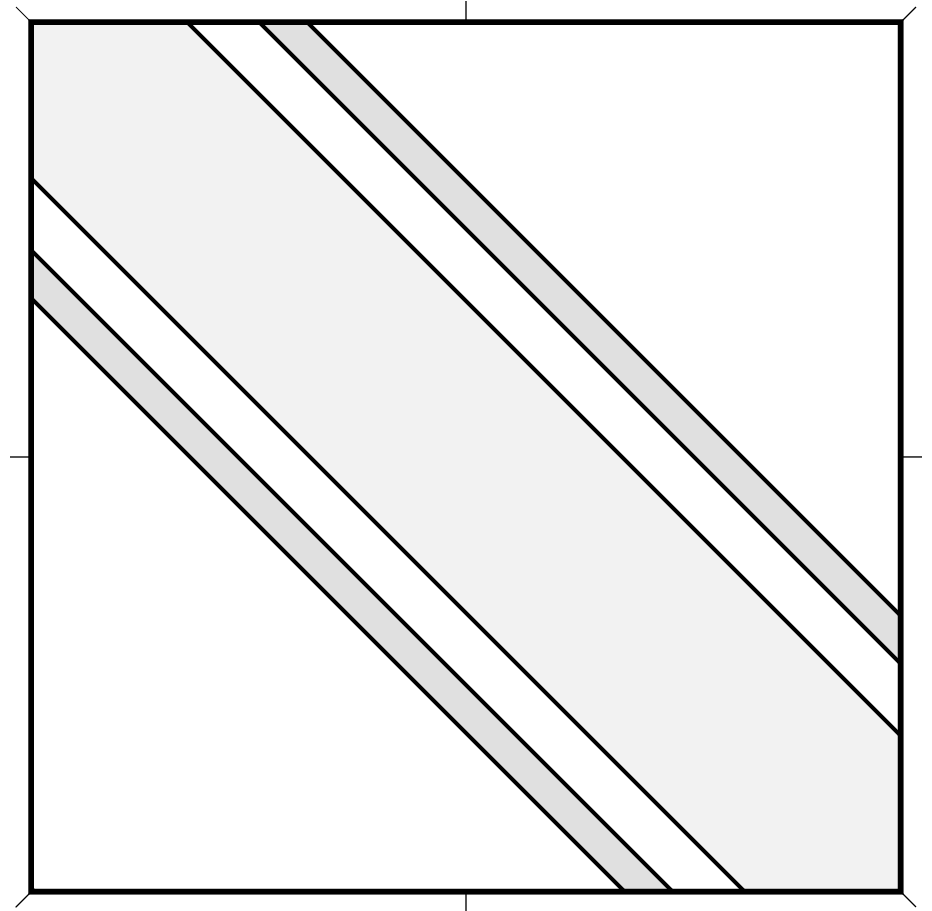
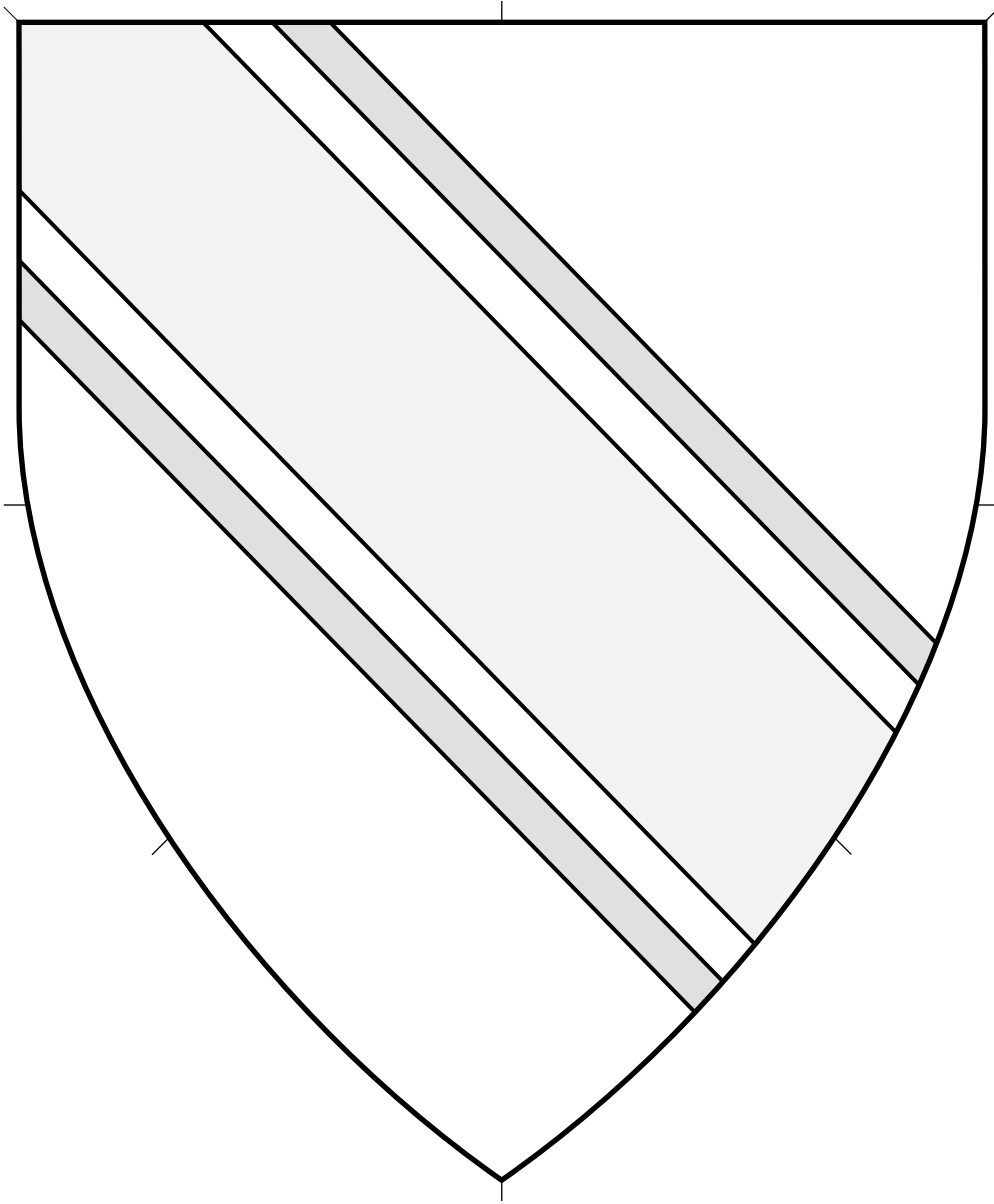

Central ordinary with secondaries.

Source: Viking Answer Lady SVG Images For Heraldry.
Artist: Gunnvôr silfrahárr. Adapted by Mathghamhain Ua Ruadháin.

Bend Cotised (2) 4.64

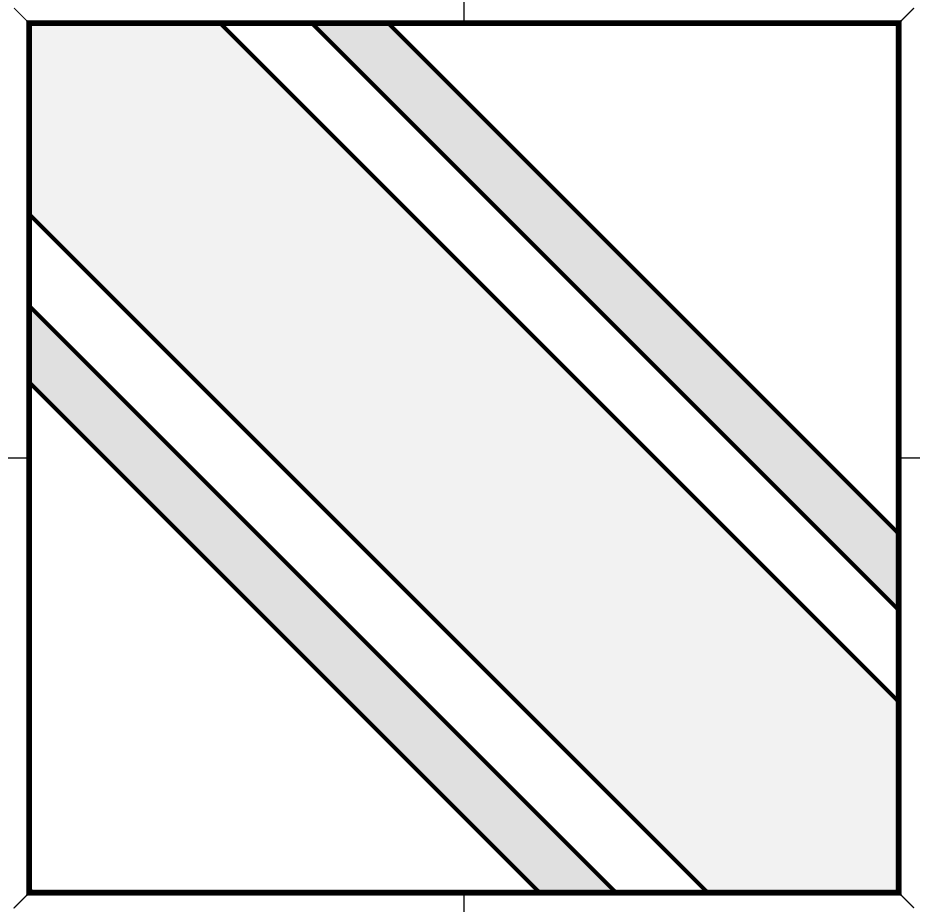
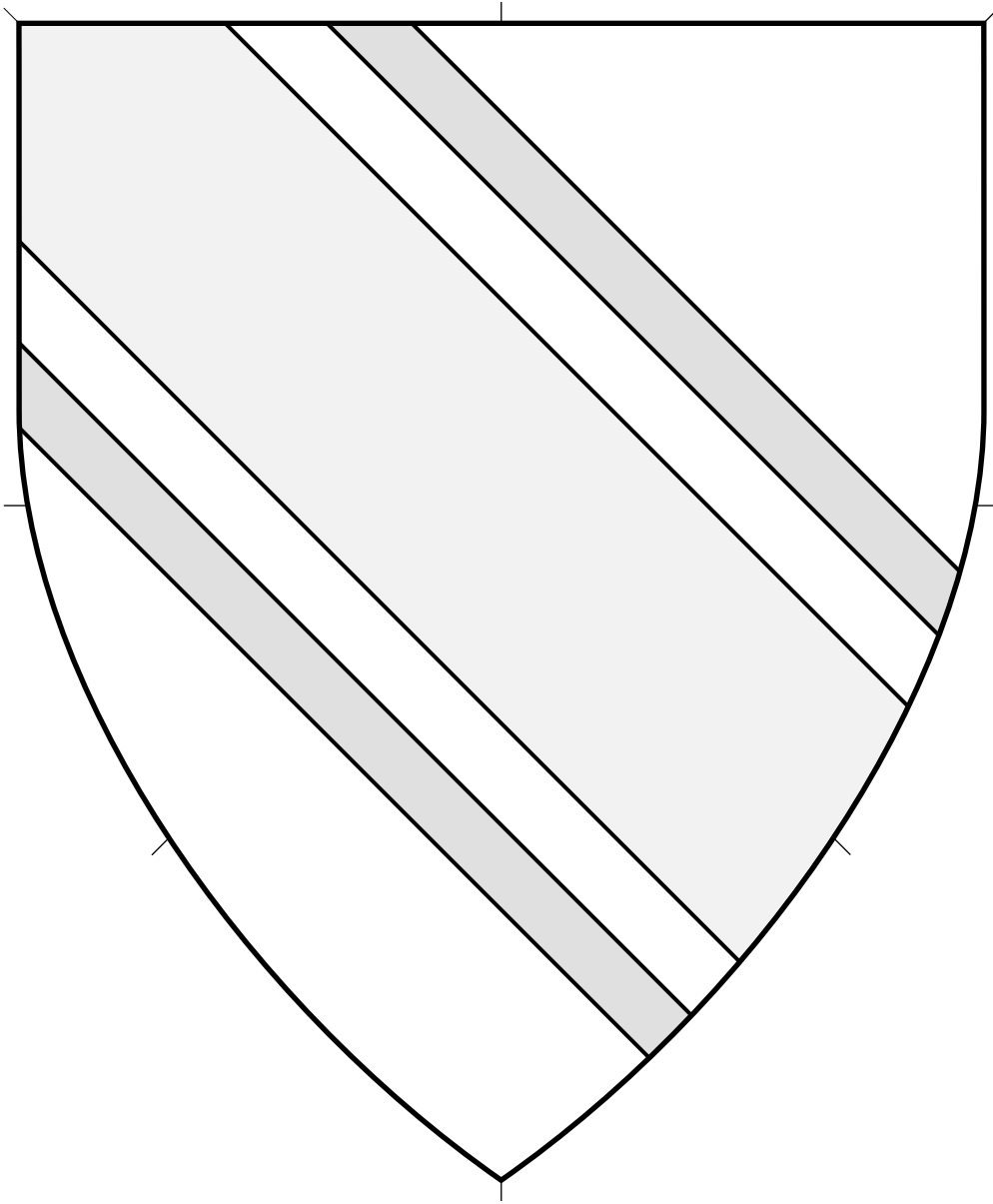

Central ordinary.

Source: English Arms A. Artist unknown. (Page 151.)

Bend Cotised (3) 4.65

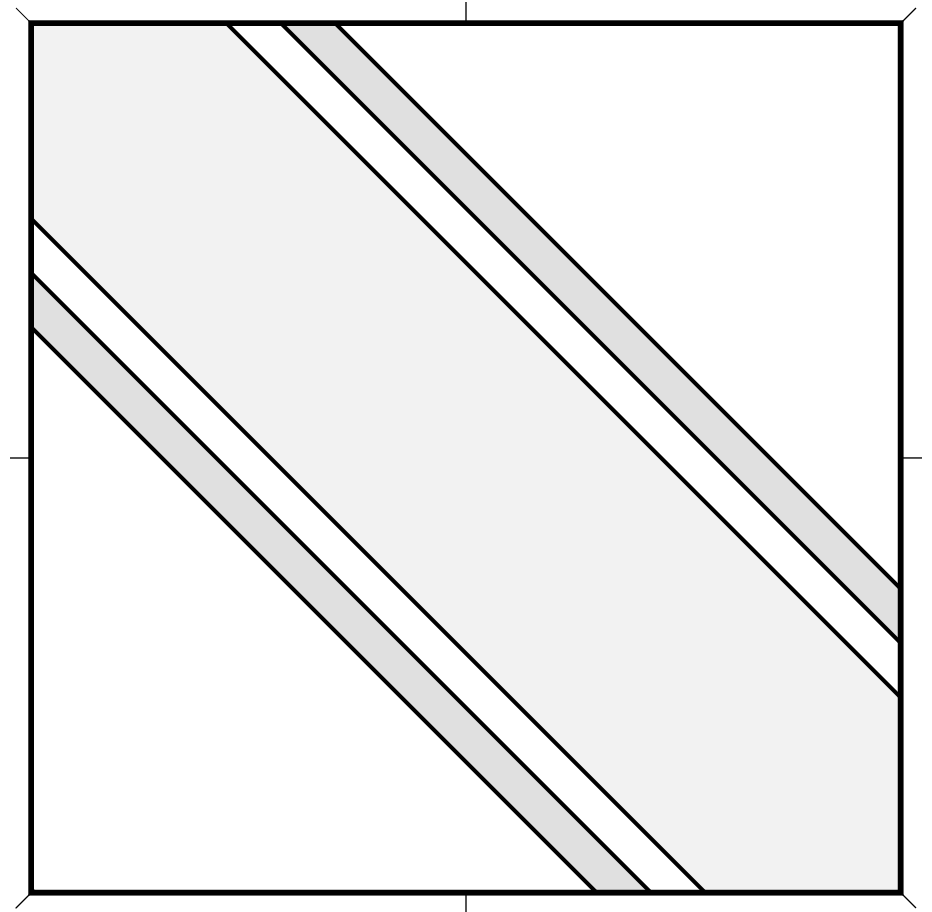
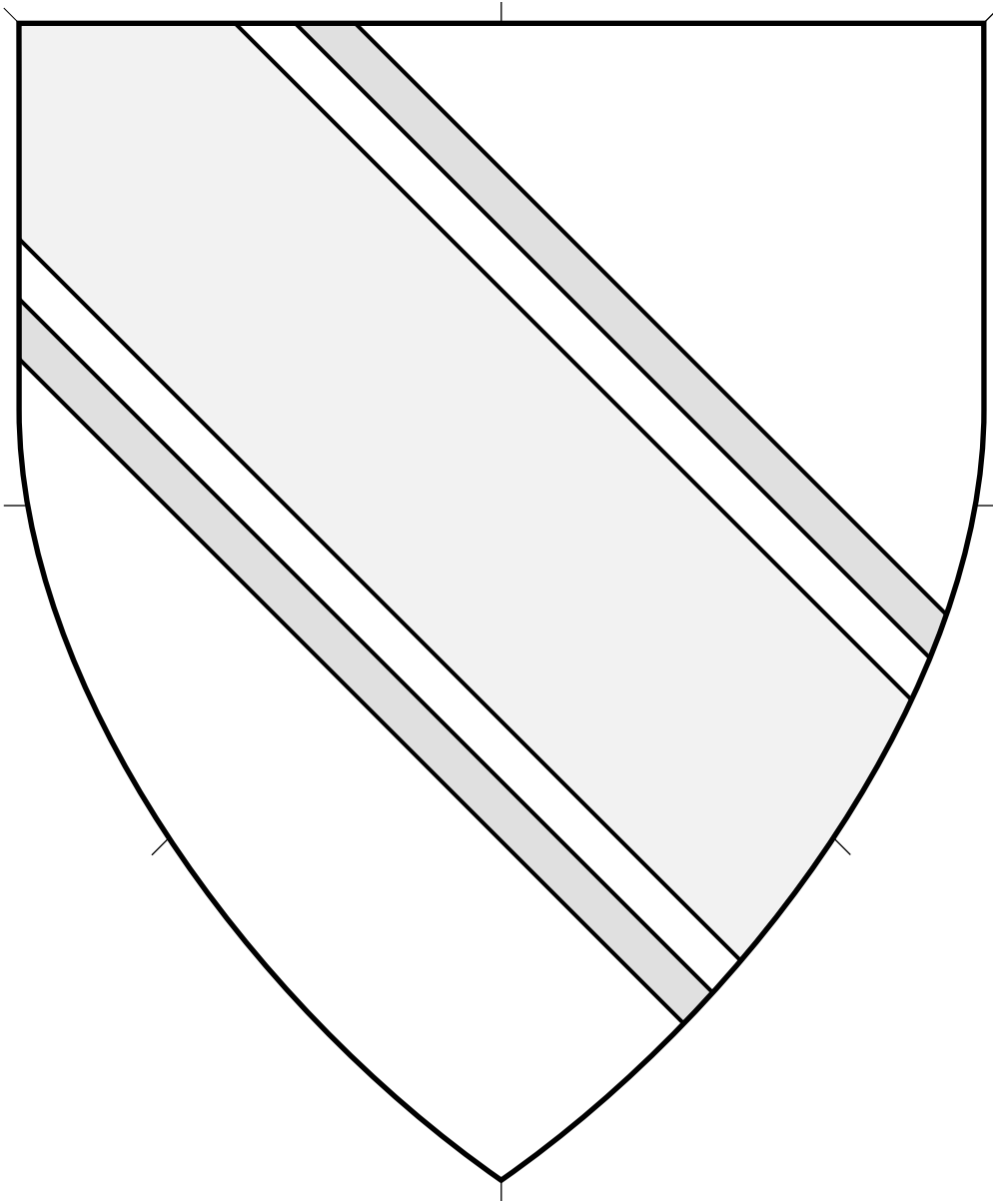

Central ordinary.

Source: Insignia Anglica. Artist unknown.

Bend Cotised (4) 4.66

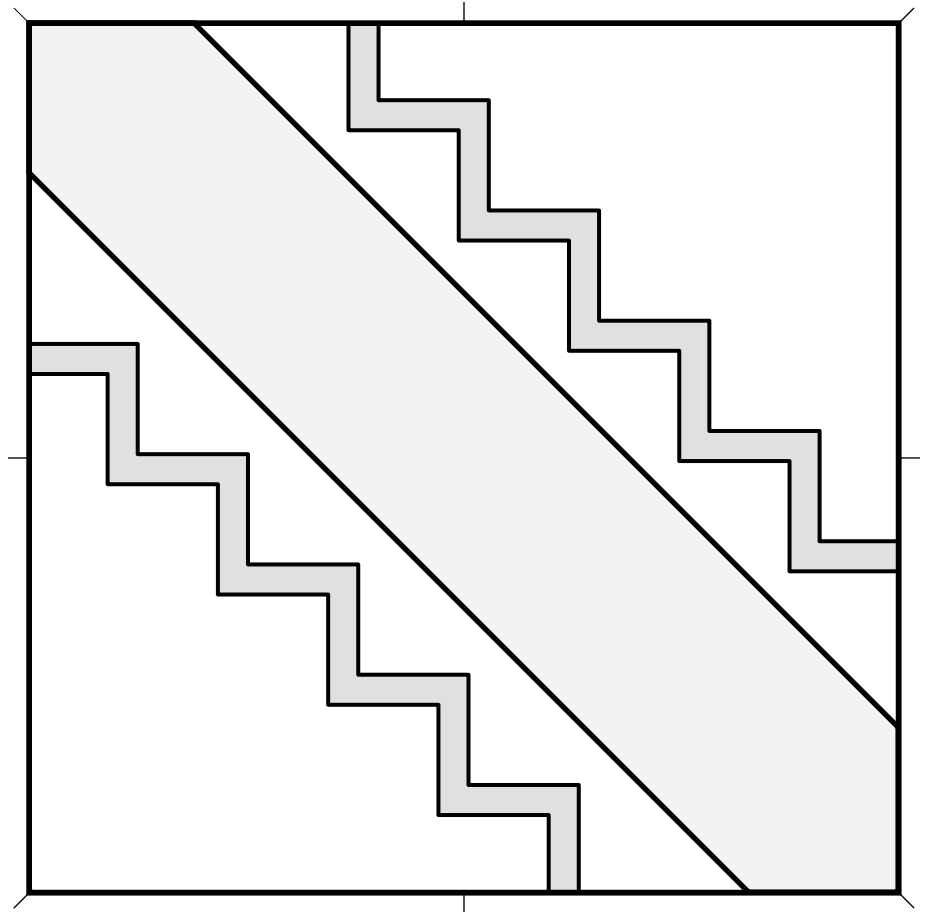
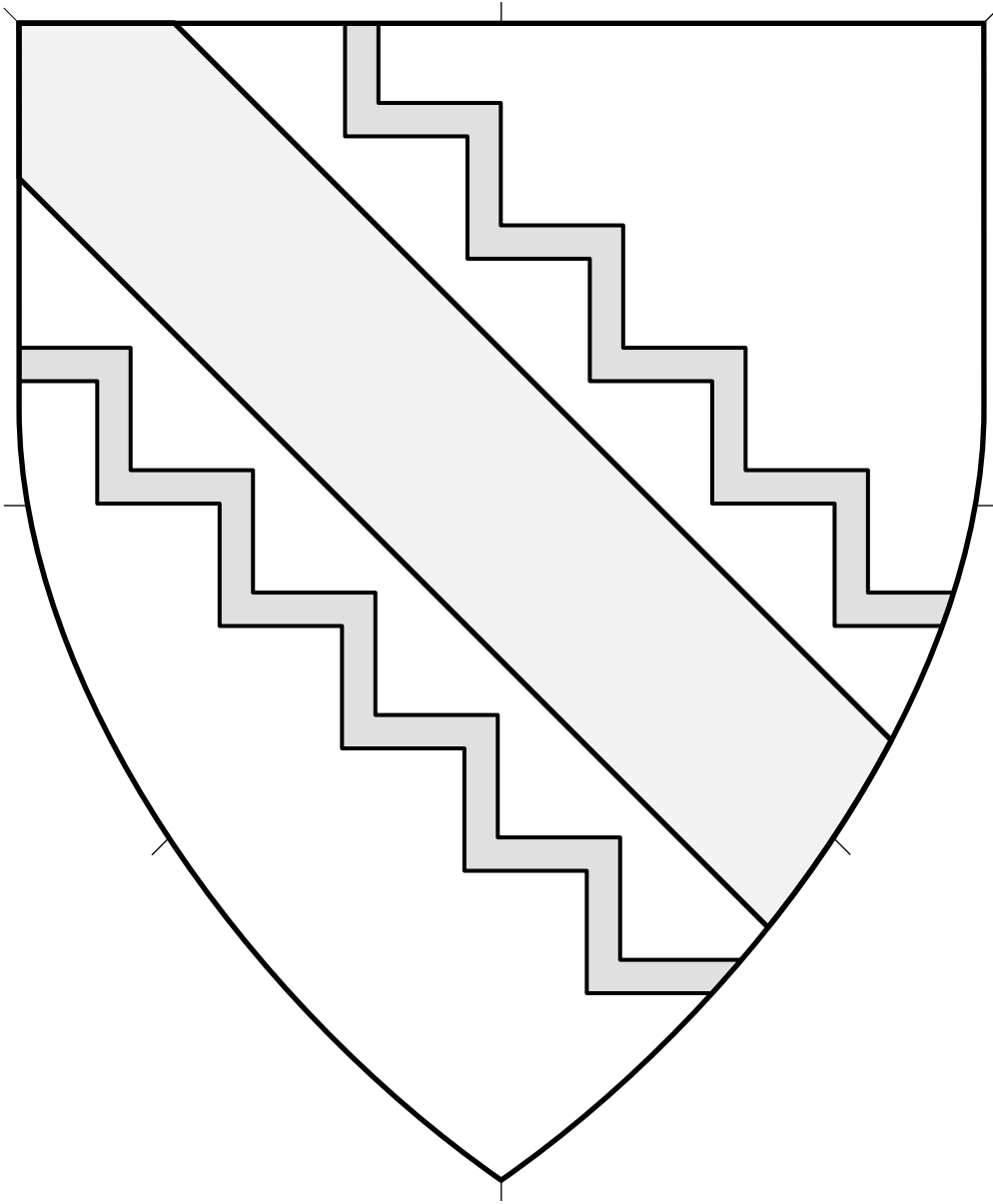

Central ordinary with secondaries.
Source: English Arms A. Artist unknown.

Bend Cotised Dancetty 4.67

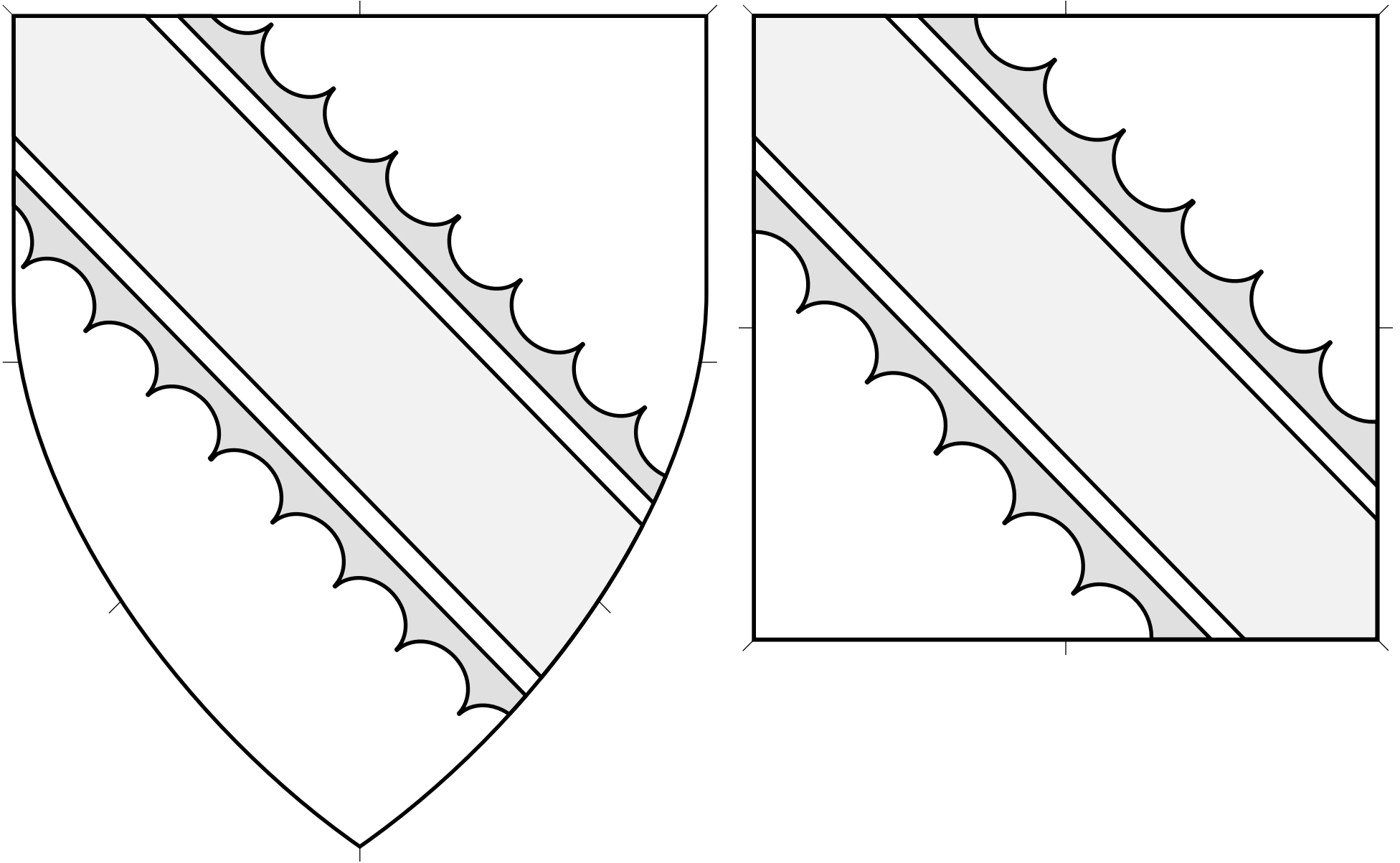

Central ordinary with secondaries.

Source: Viking Answer Lady SVG Images For Heraldry. Artist: Gunnvôr silfrahárr. Adapted by Mathghamhain Ua Ruadháin.

Bend Cotised Engrailed On The Outer Edge 4.68

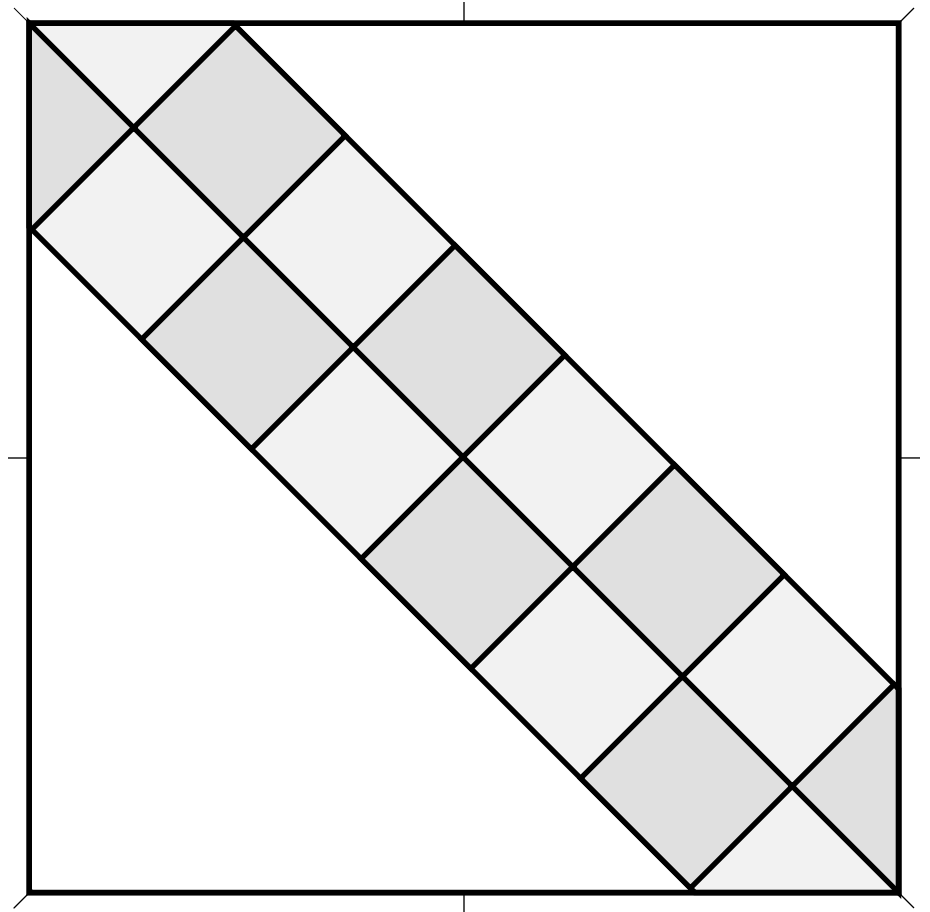
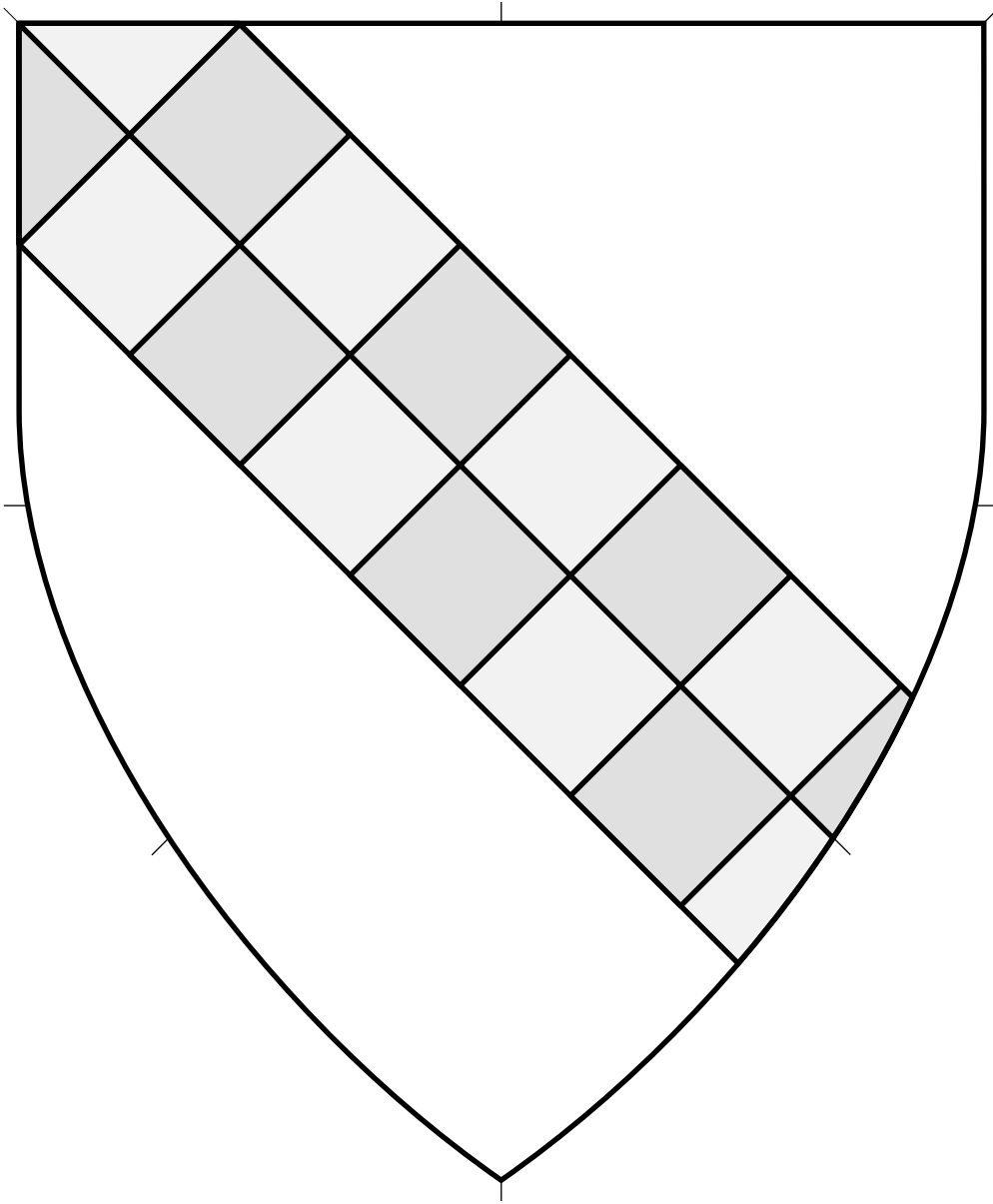

Central ordinary. Two contrasting tinctures.

Bend Counter-compony 4.69

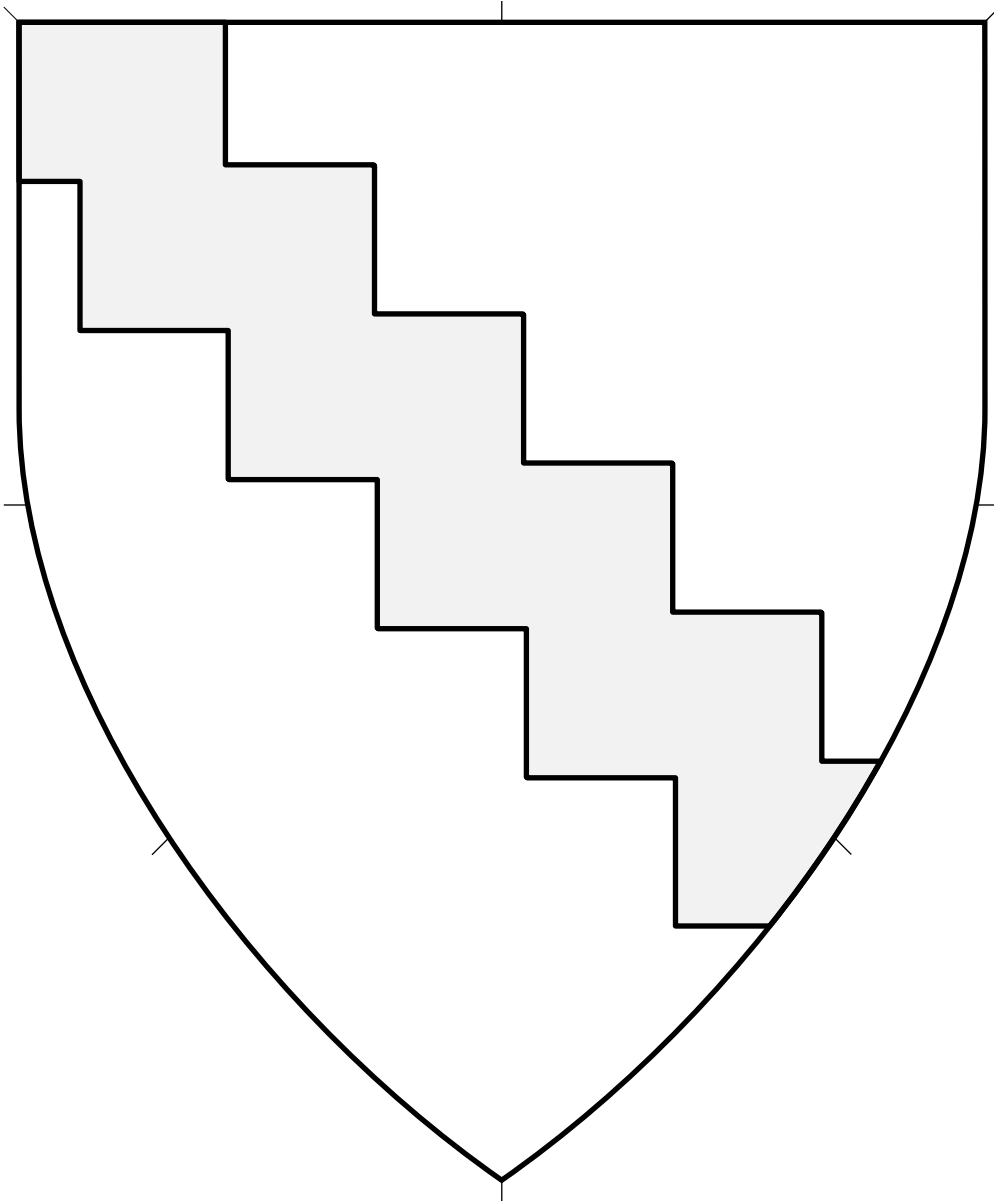

Central ordinary.

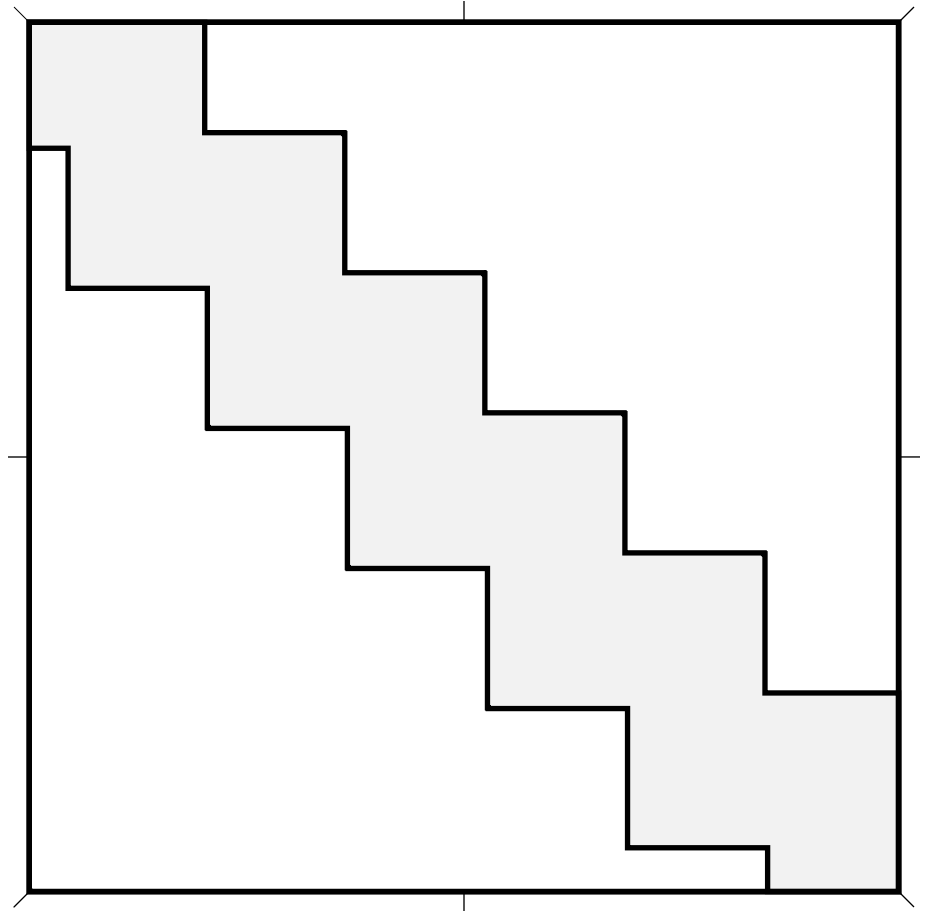

Bend Dancetty (1) 4.70

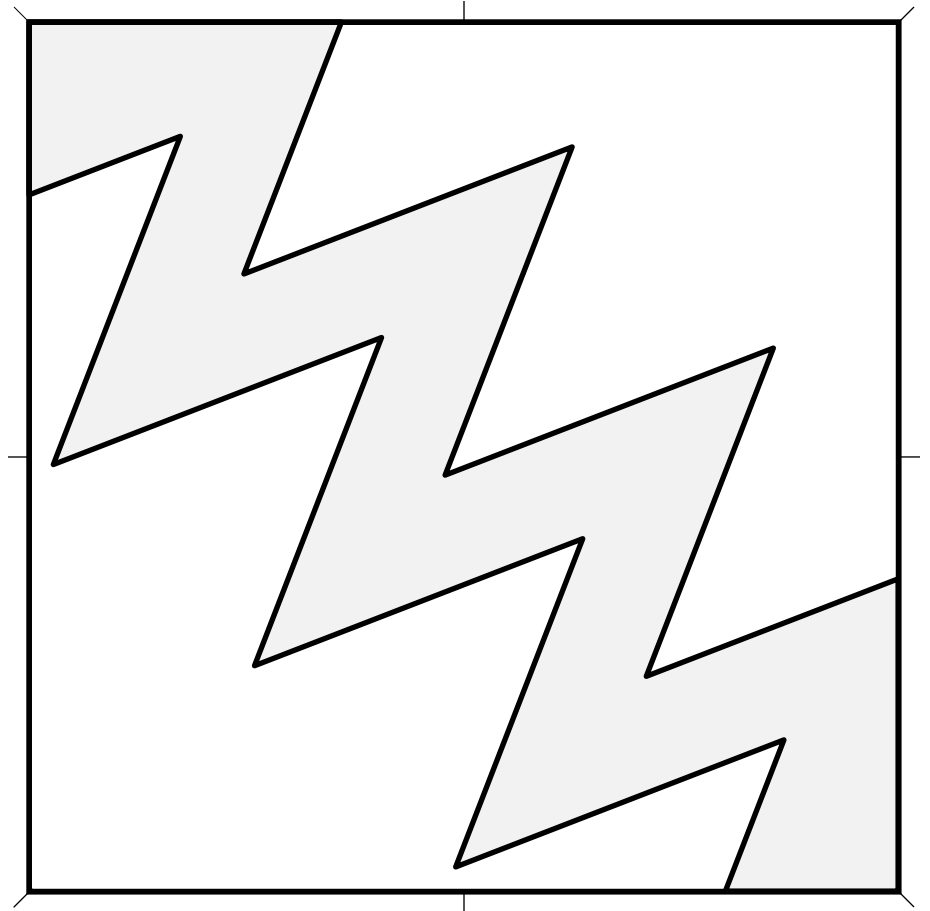
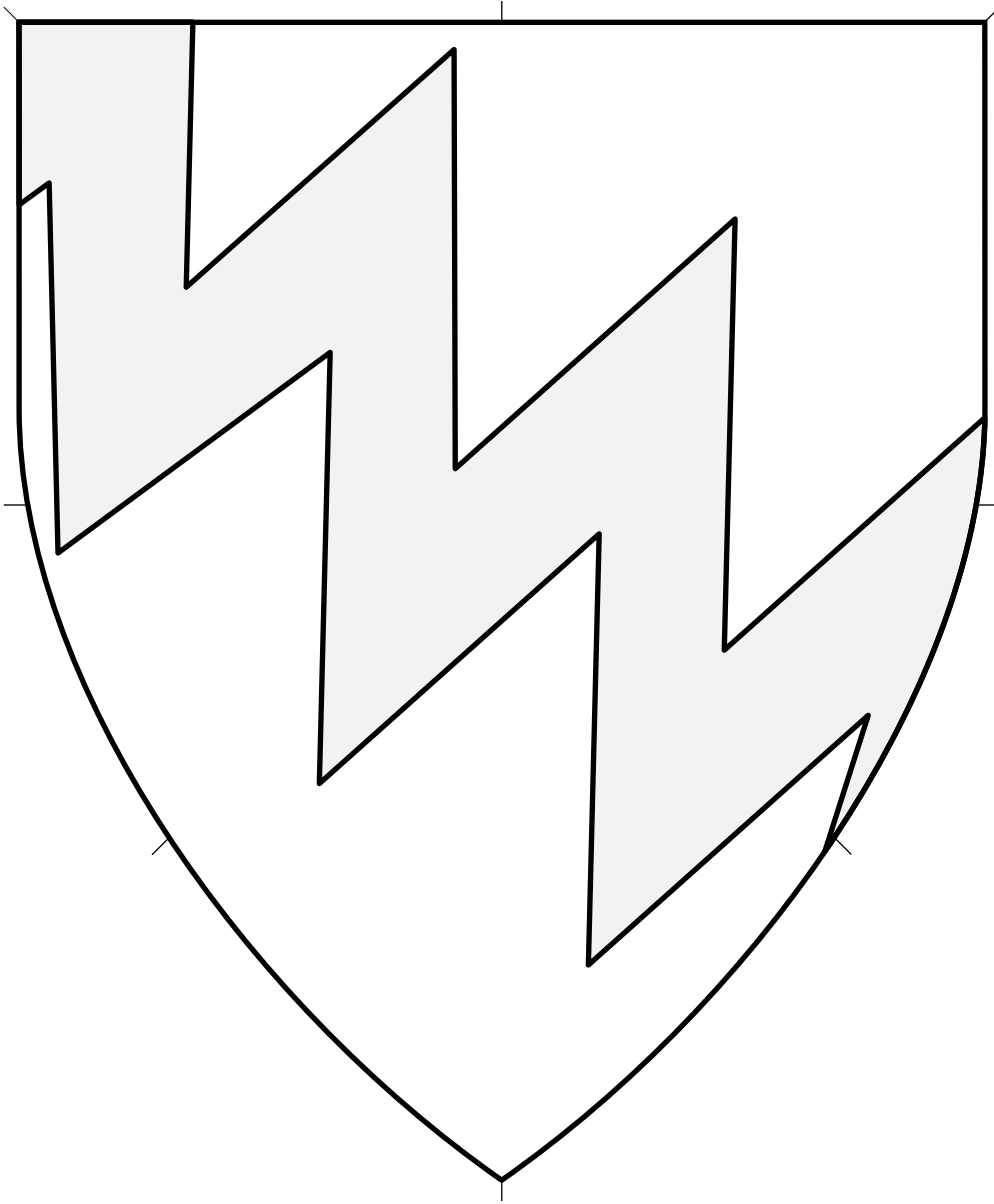

Central ordinary.

Source: Thomas Jenyn's Book. Artist unknown. (Folio 95r.)

Bend Dancetty (2) 4.71

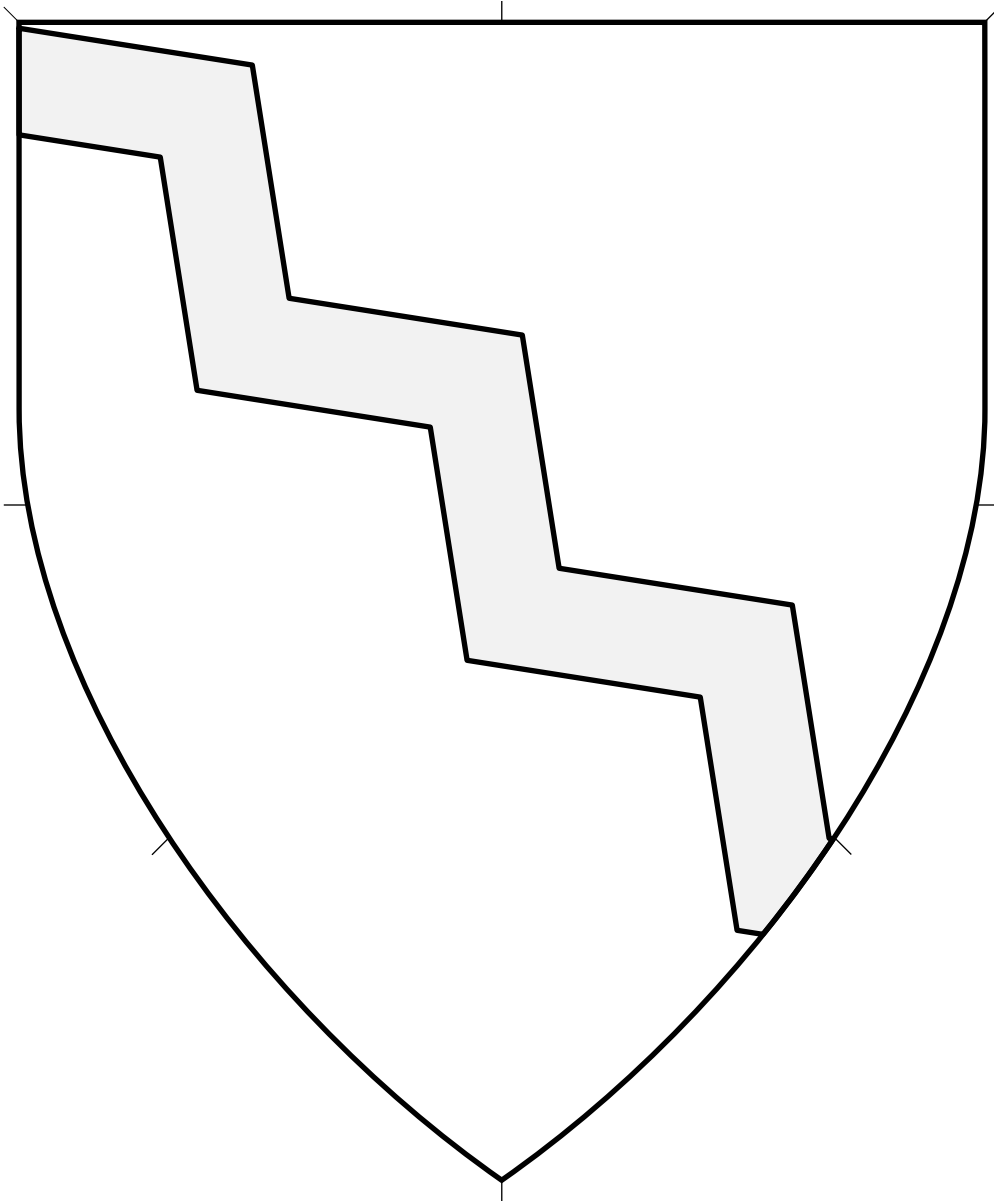

Central ordinary.

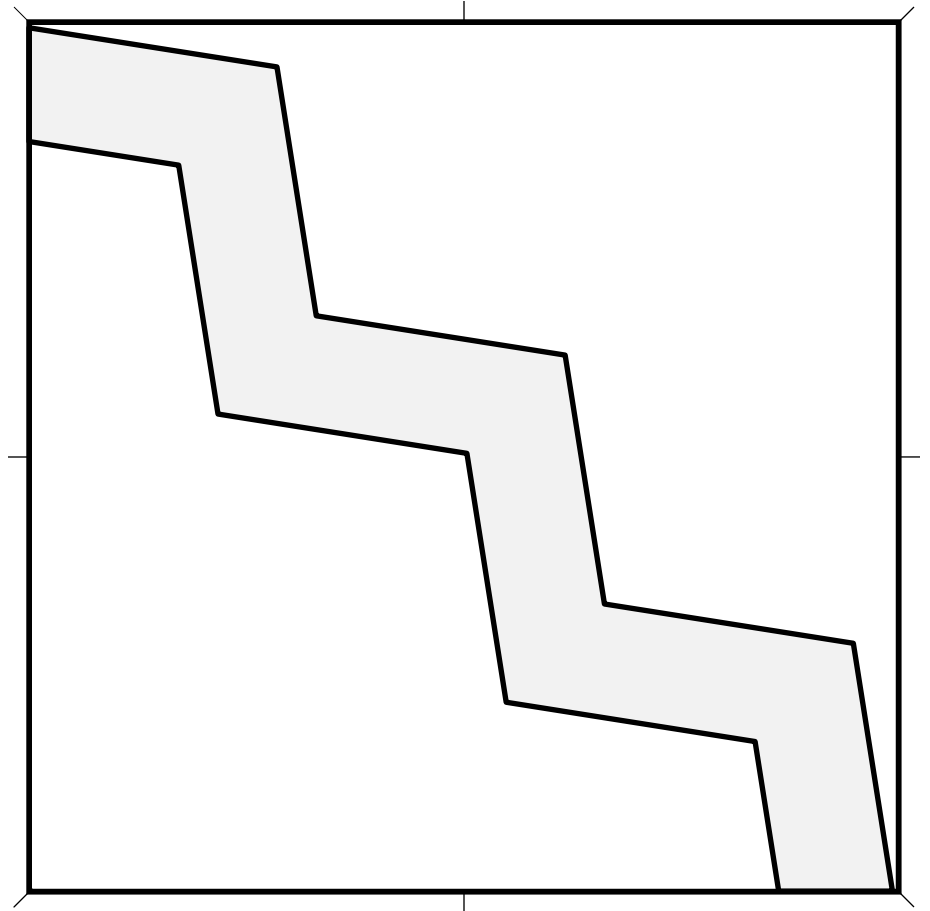

Bend Dancetty (3) 4.72

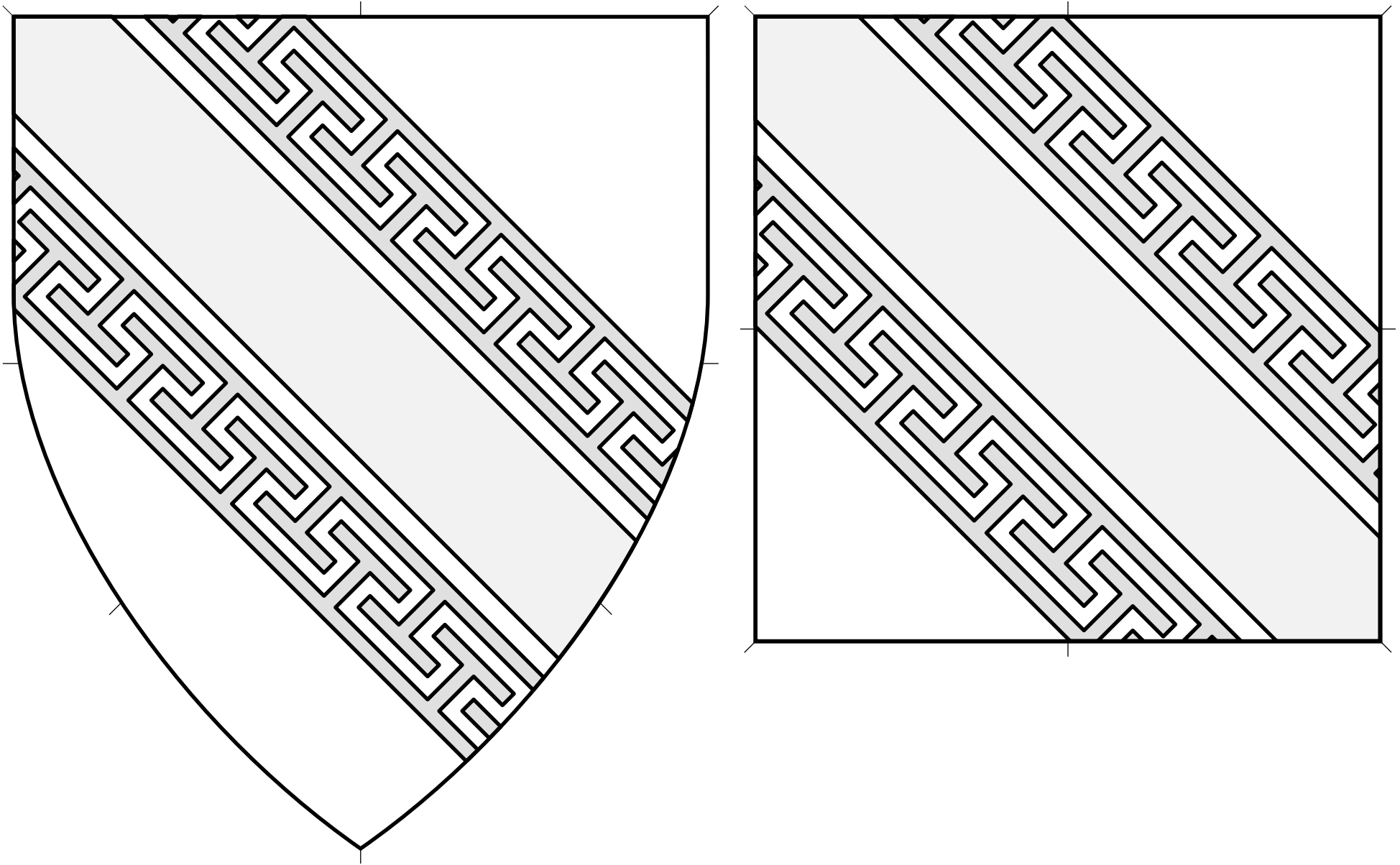

Central ordinary.

Source: Sammelband Mehrerer Wappenbücher. Artist unknown. (Arms of the Counts of Champagne.)

Bend Double Cotised Interiors Potent Counter-potent • 4.73

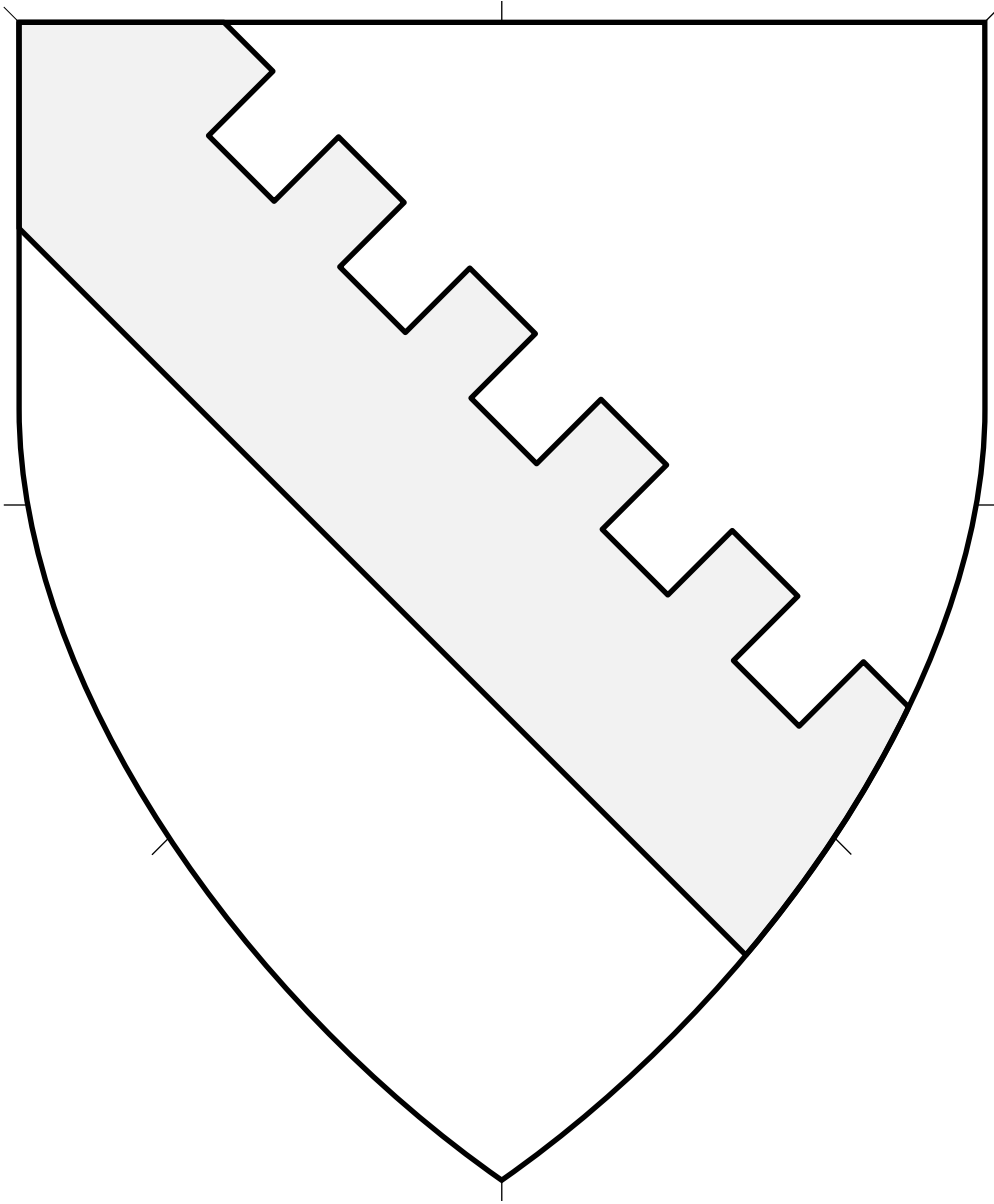

Central ordinary.

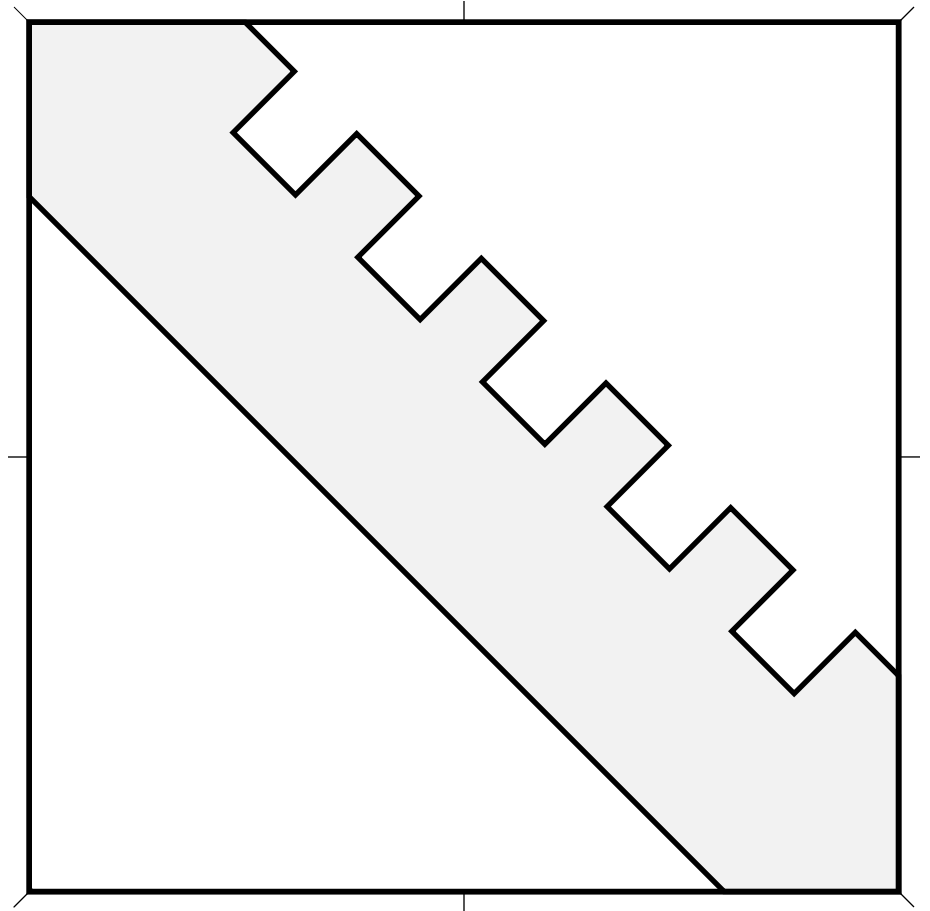

Bend Embattled 4.74

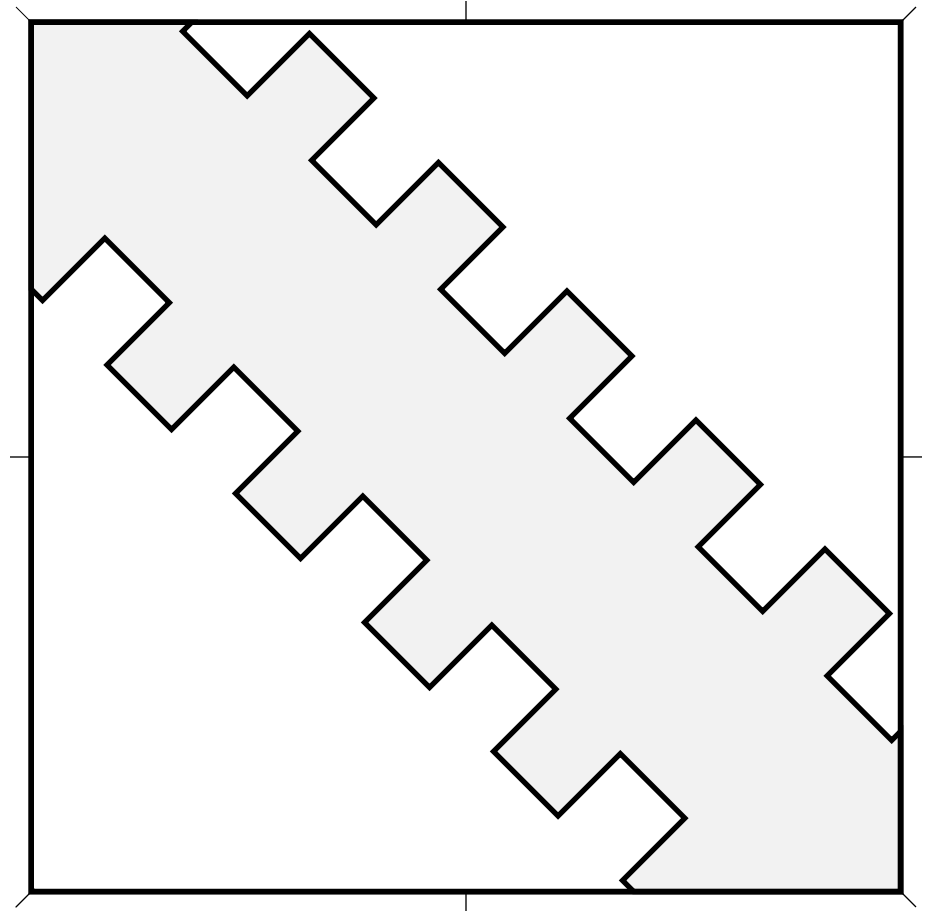
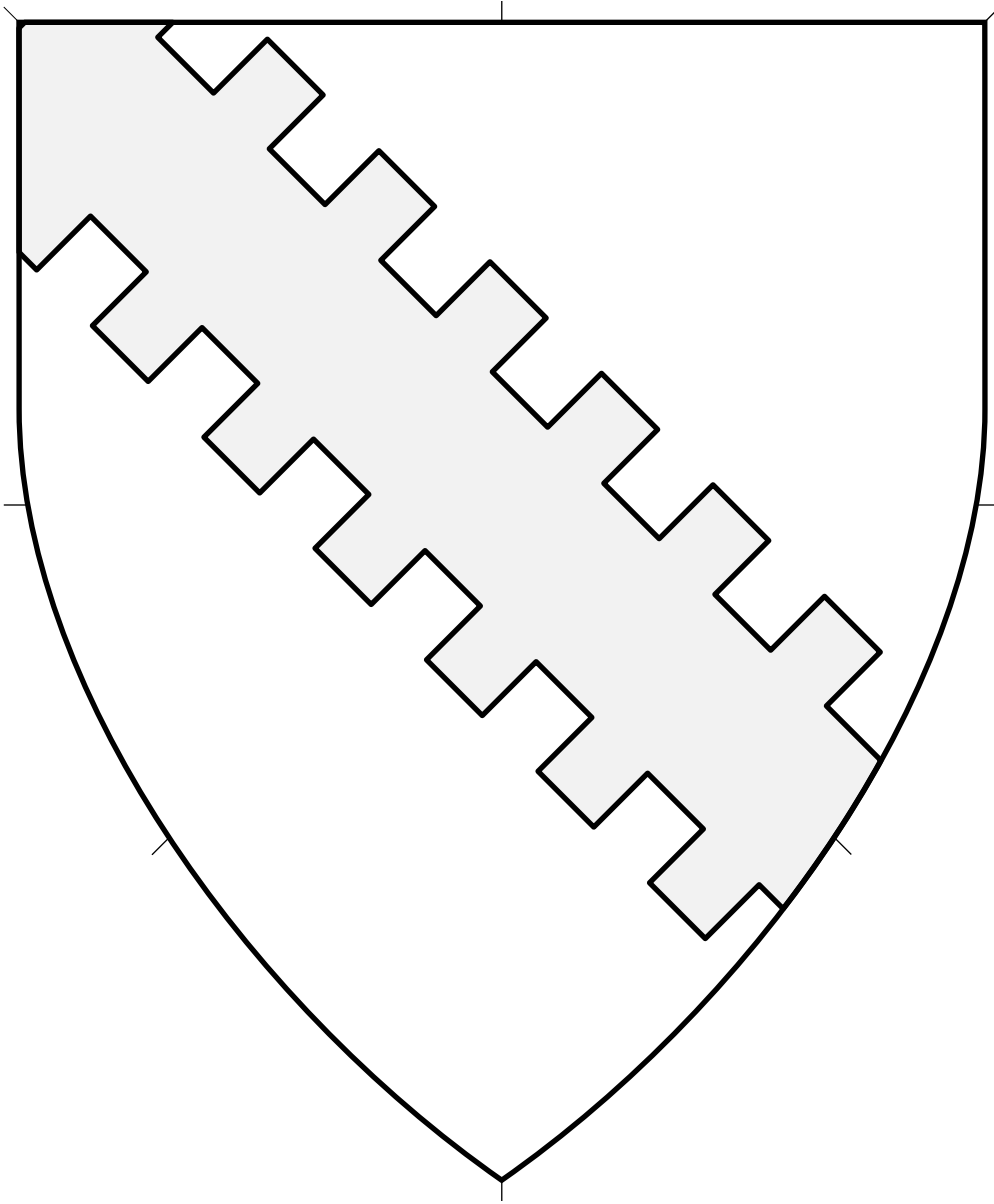

Central ordinary.

Bend Embattled Counter-embattled (1) • 4.75

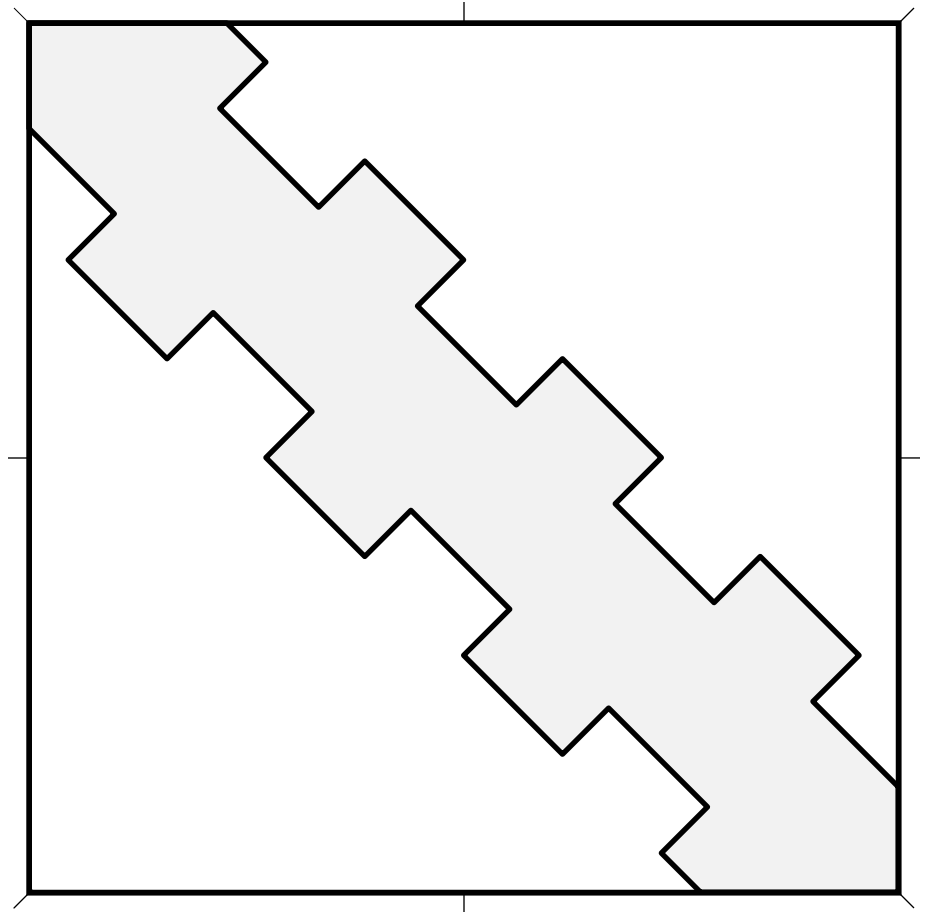
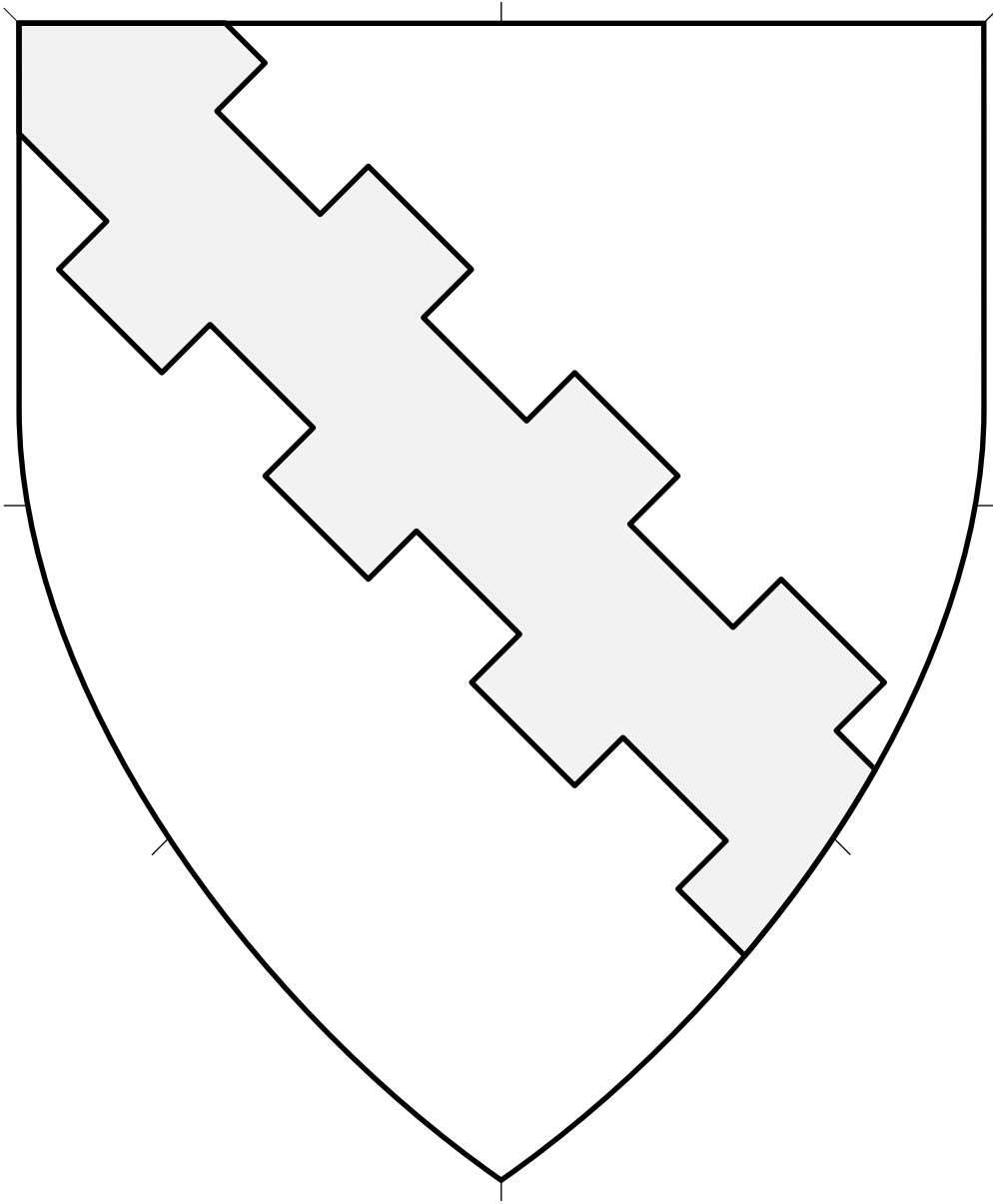

Central ordinary.

Source: Wapenboek van Gent.
Artist: Vander Schelden.
(Volume 1, page 152.)

Bend Embattled Counter-embattled (2) 4.76

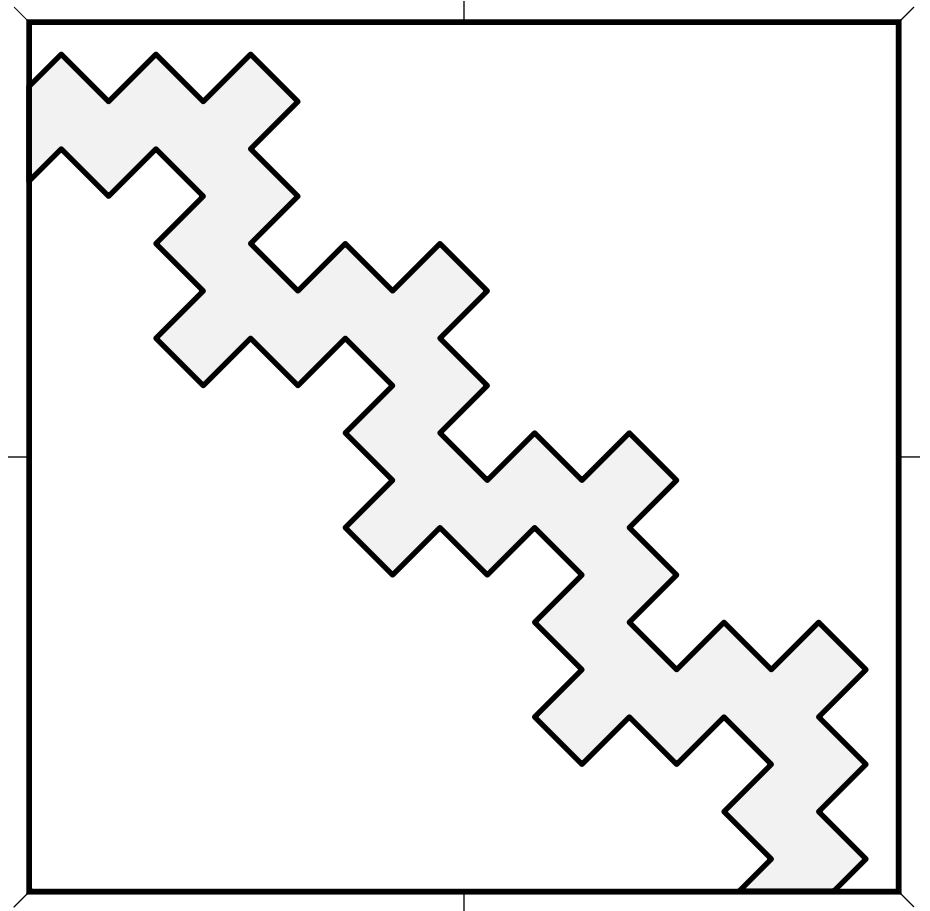
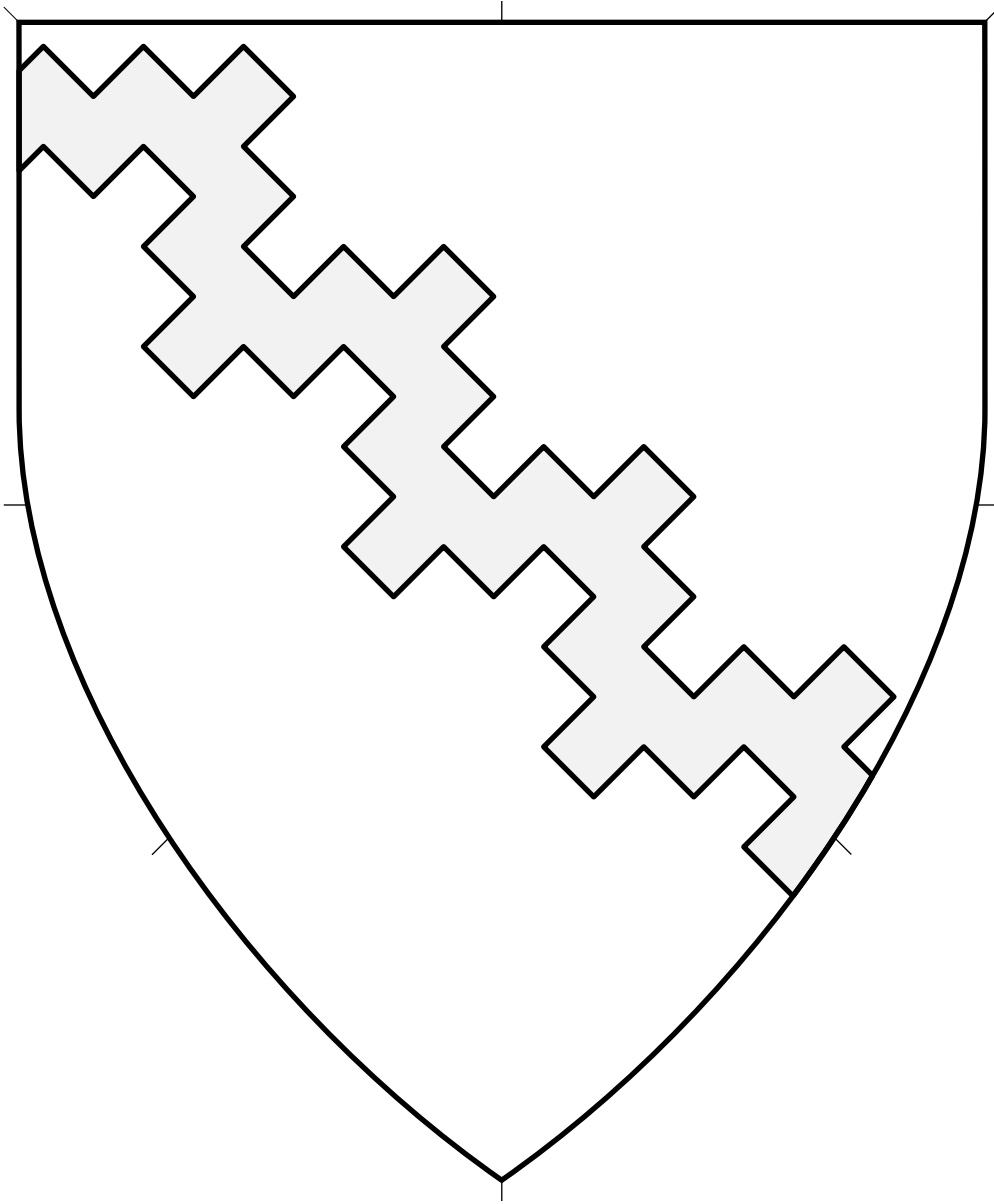

Central ordinary.

Source: Society of Antiquaries MS 644 Vol IX. Artist unknown.

Bend Embattled Grady 4.77

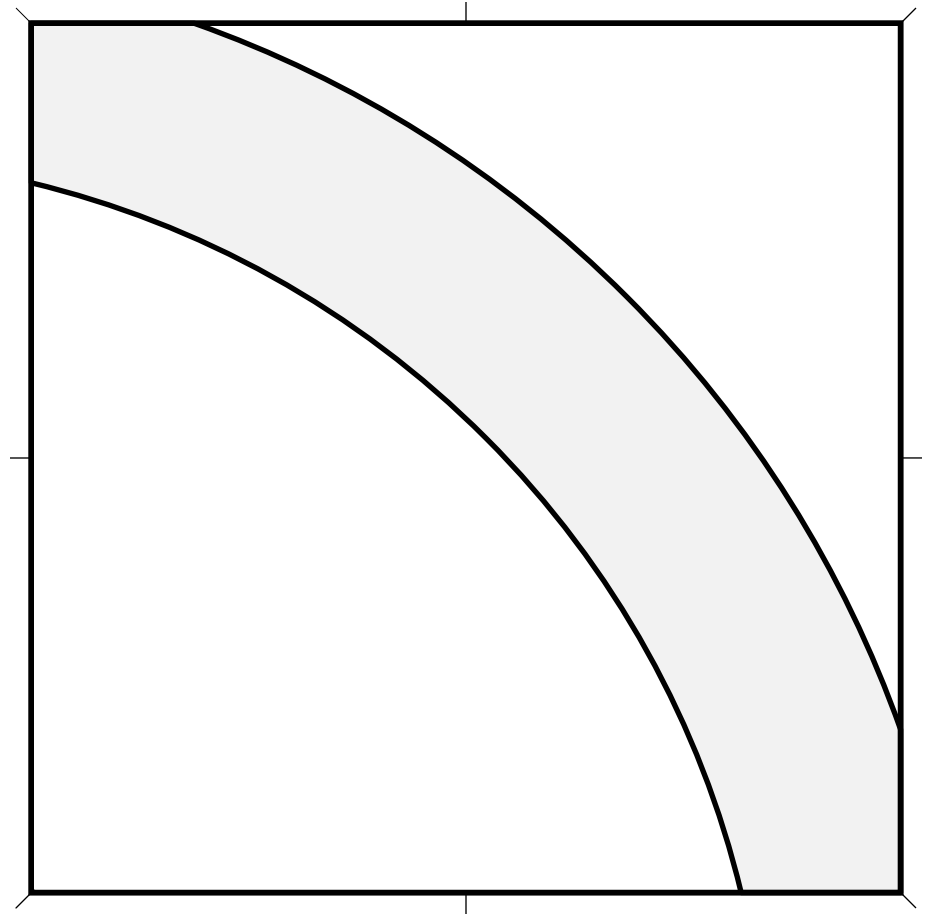
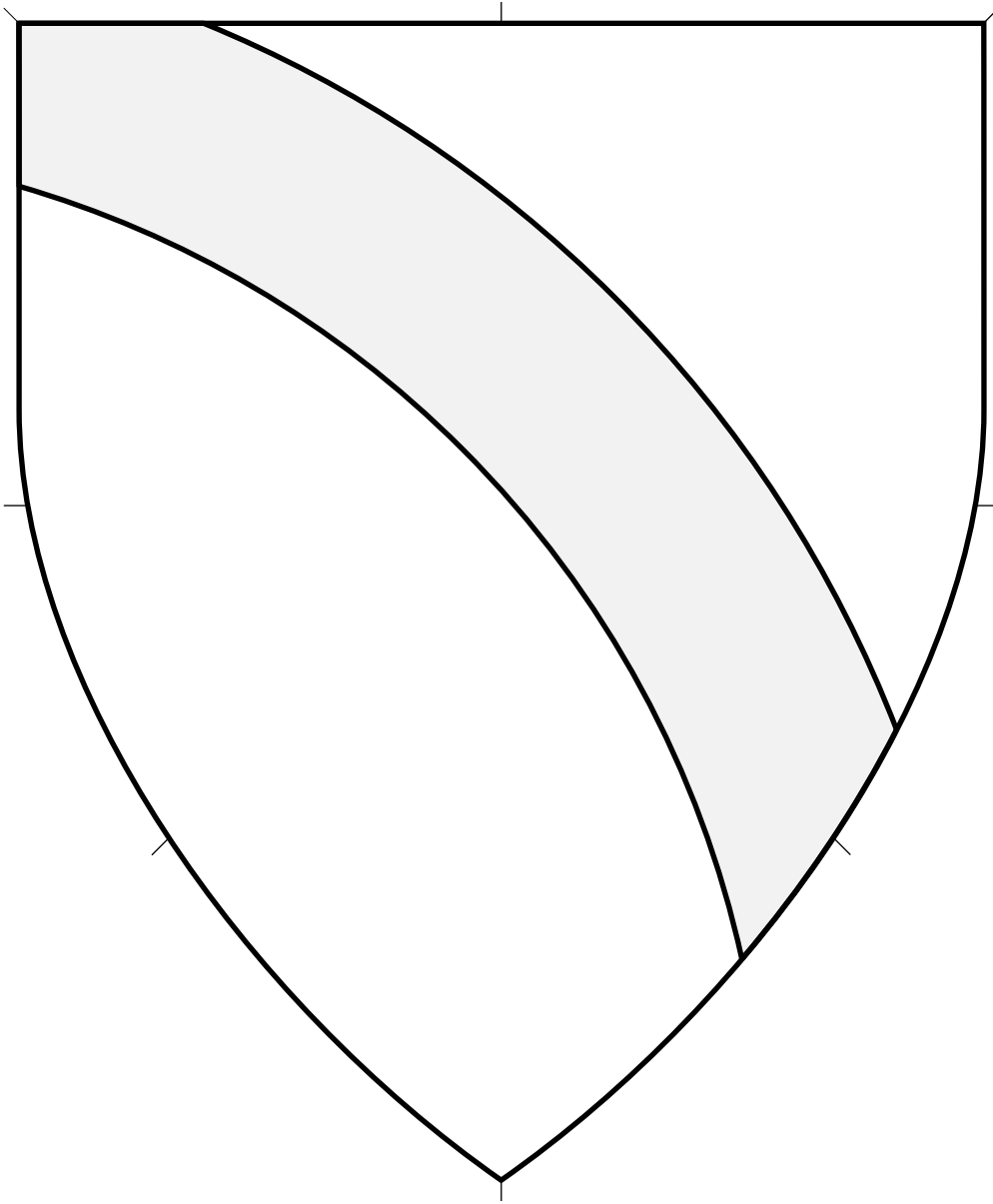

Central ordinary. A bend embowed to chief.

Bend Enarched 4.78

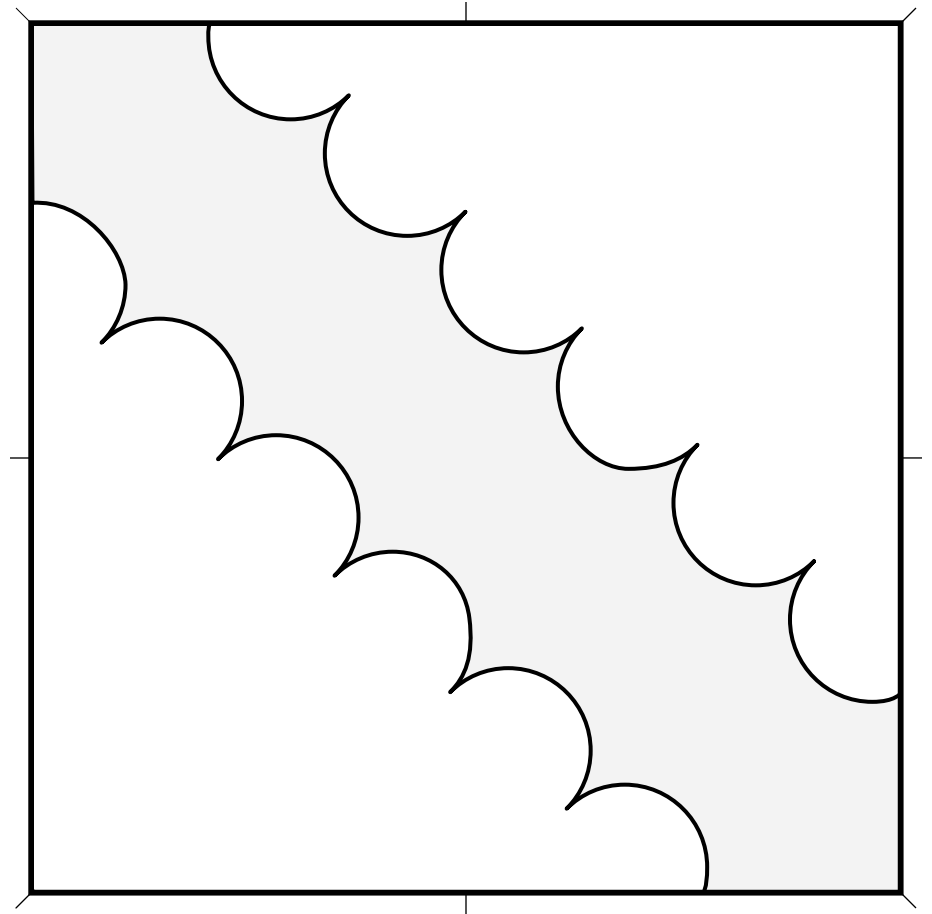
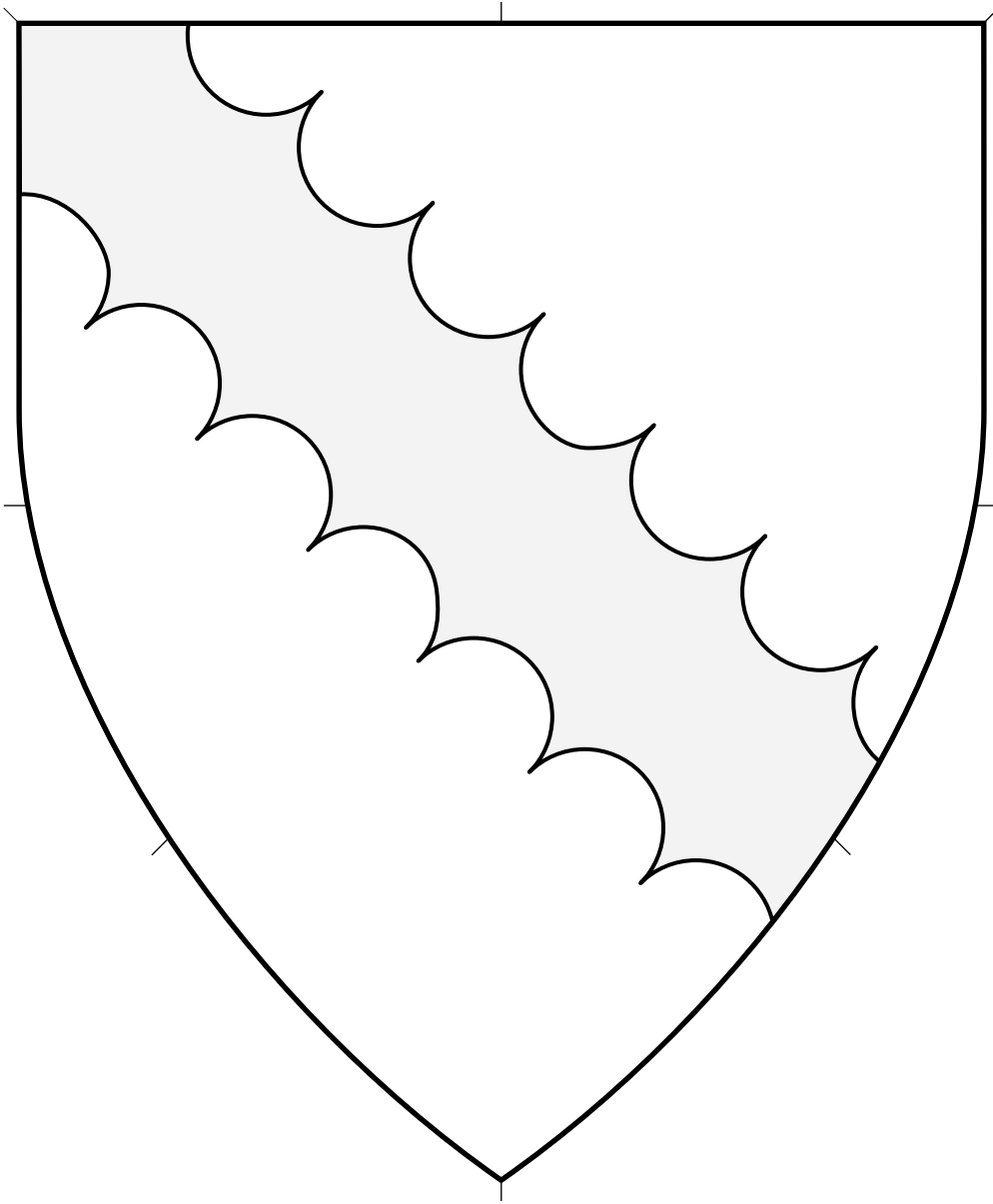

Central ordinary.

Artist: Elionora inghean Ui Cheallaigh.
Adapted by Mathghamhain Ua Ruadháin.

Bend Engrailed (1) 4.79

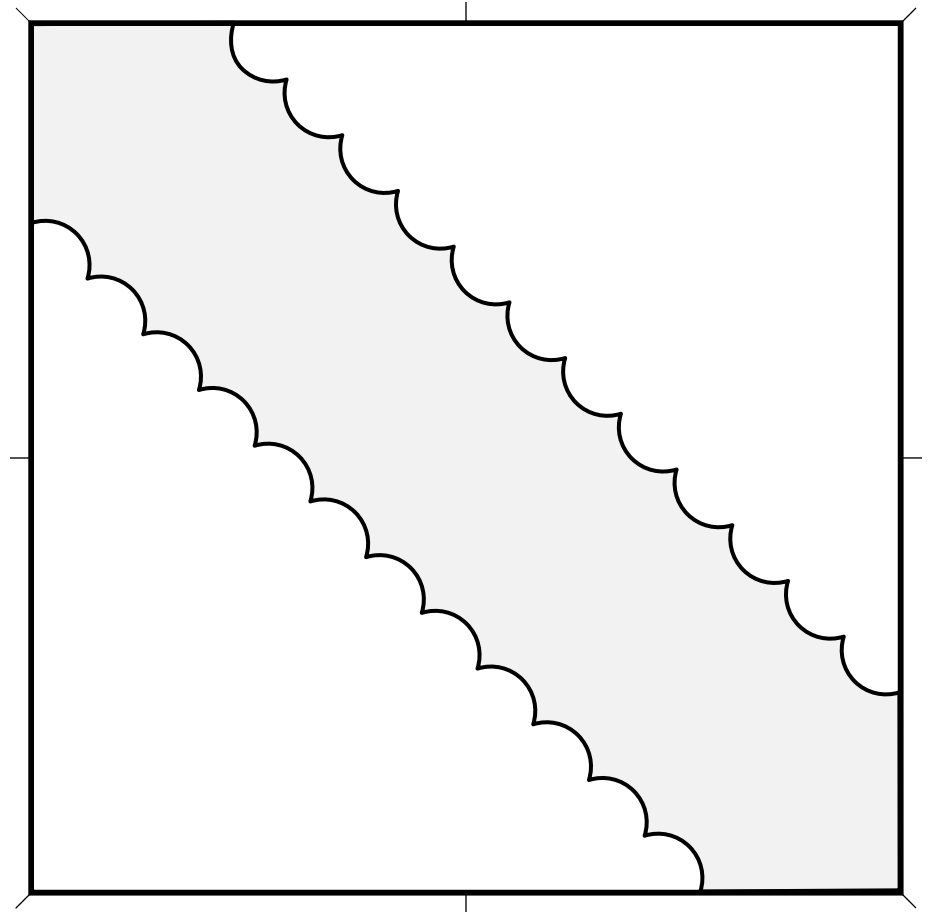
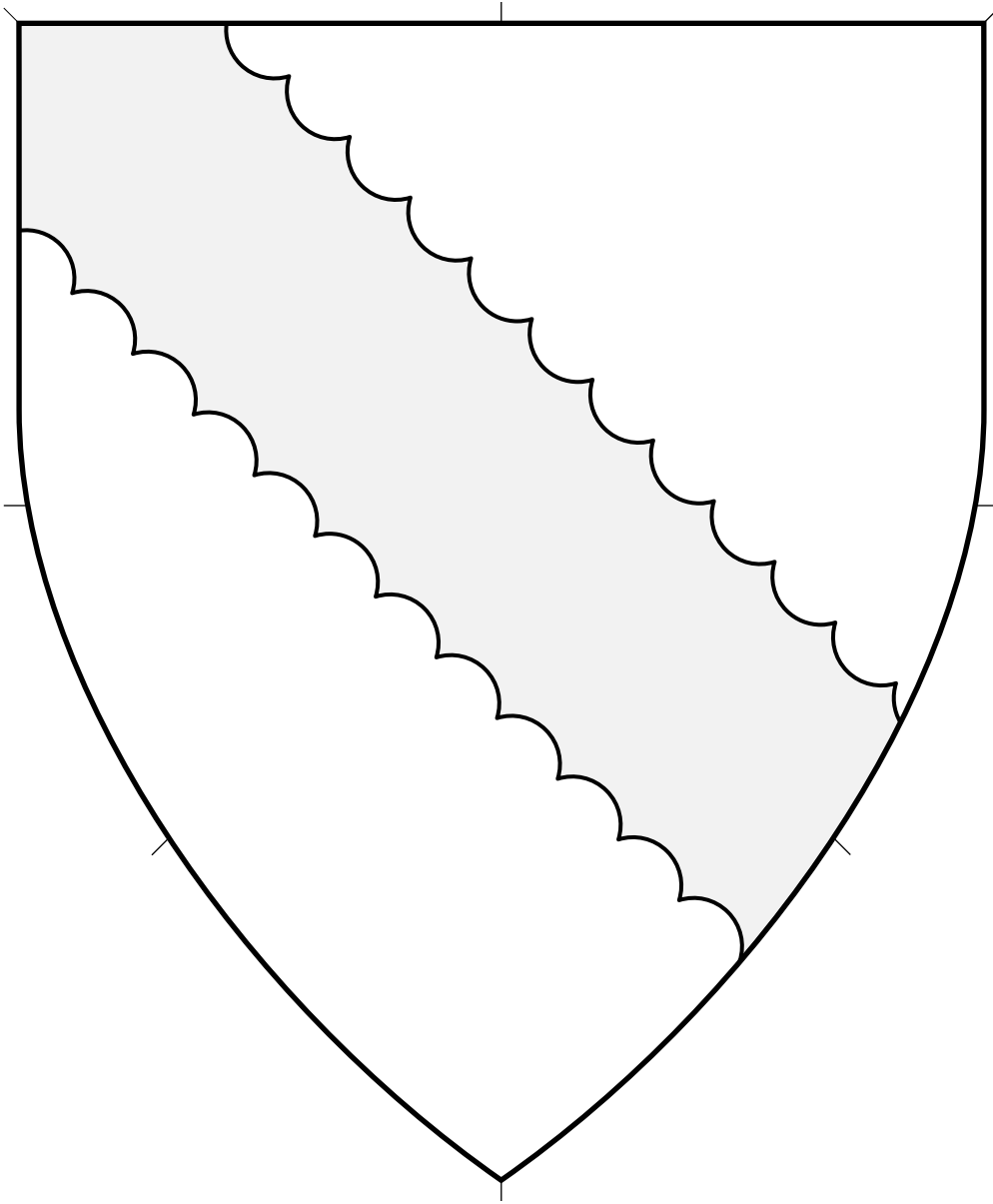

Central ordinary.

Source: Insignia Anglica. Artist unknown.
(Folio 50r.)

Bend Engrailed (2) 4.80

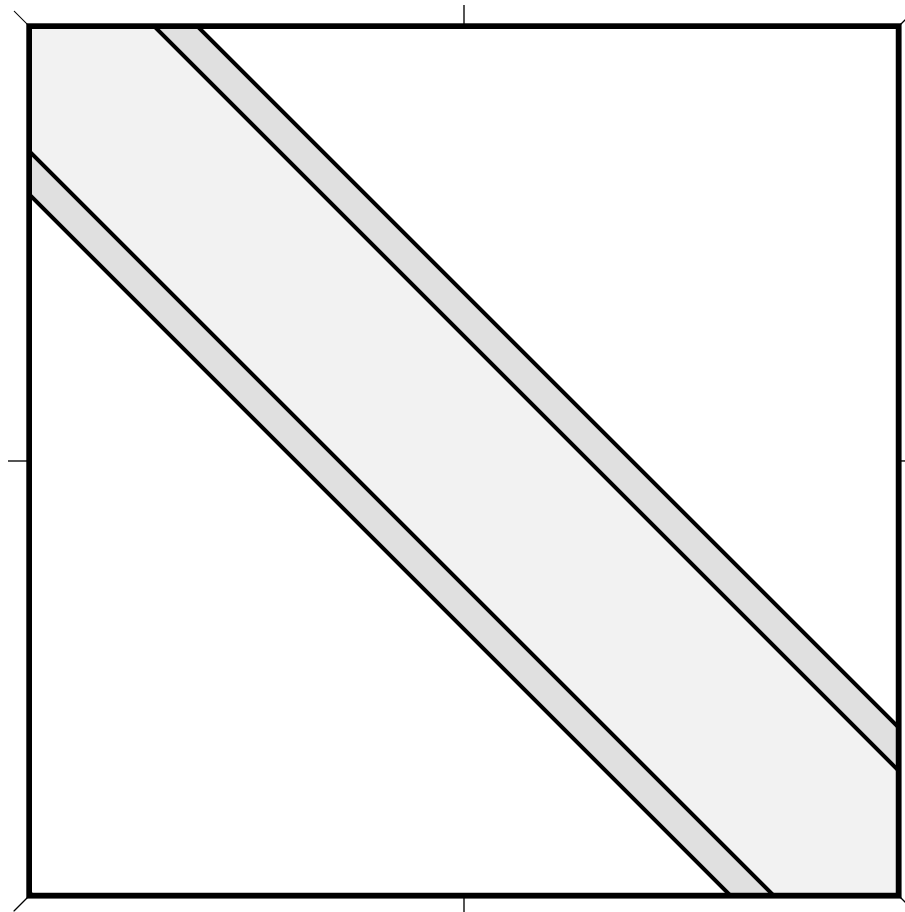
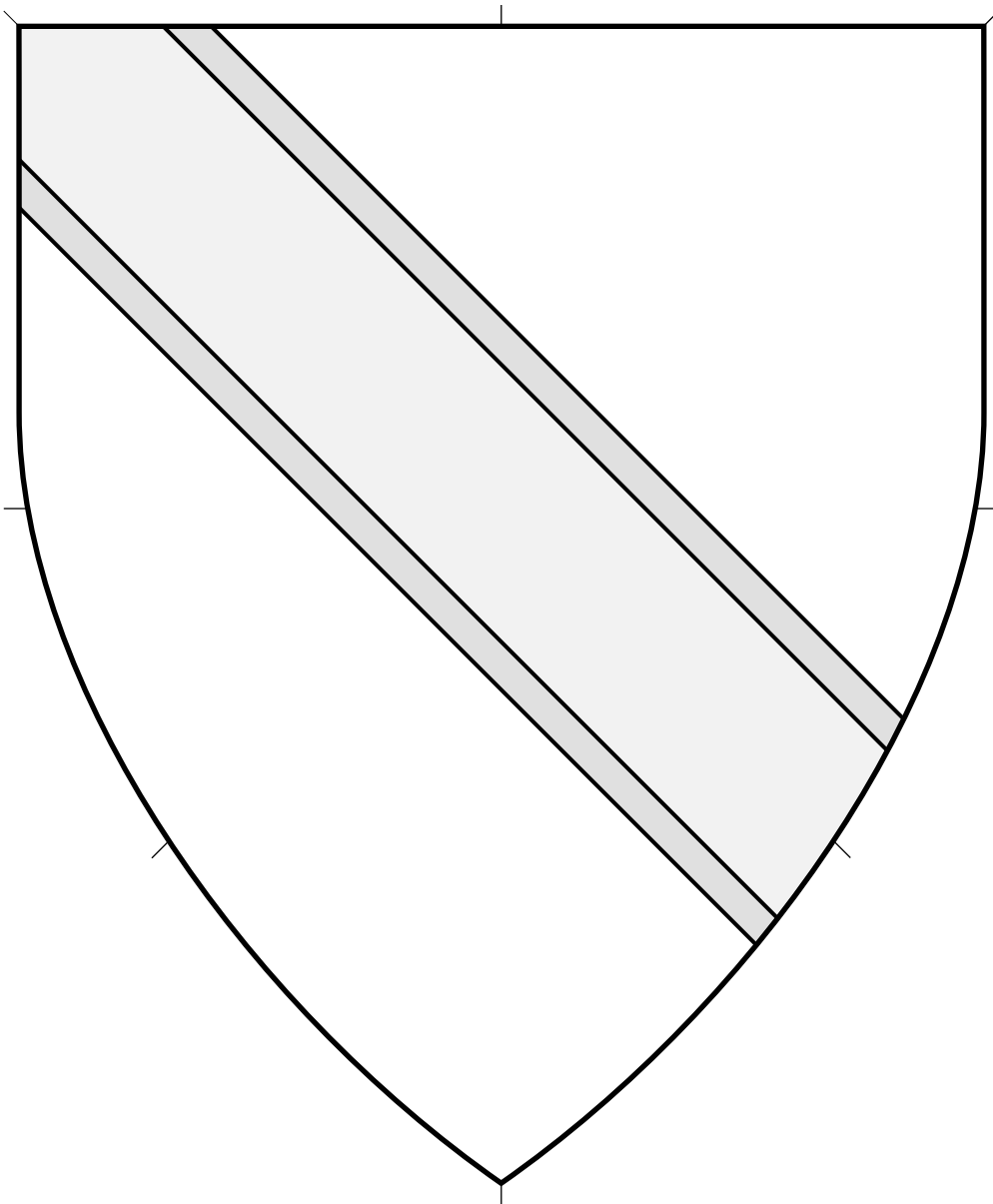

Central ordinary.

Source: Armorial Français et Plus Particulièrement Poitevin.
Artist unknown. (Folio 38r.)

Bend Fimbriated (1) 4.81

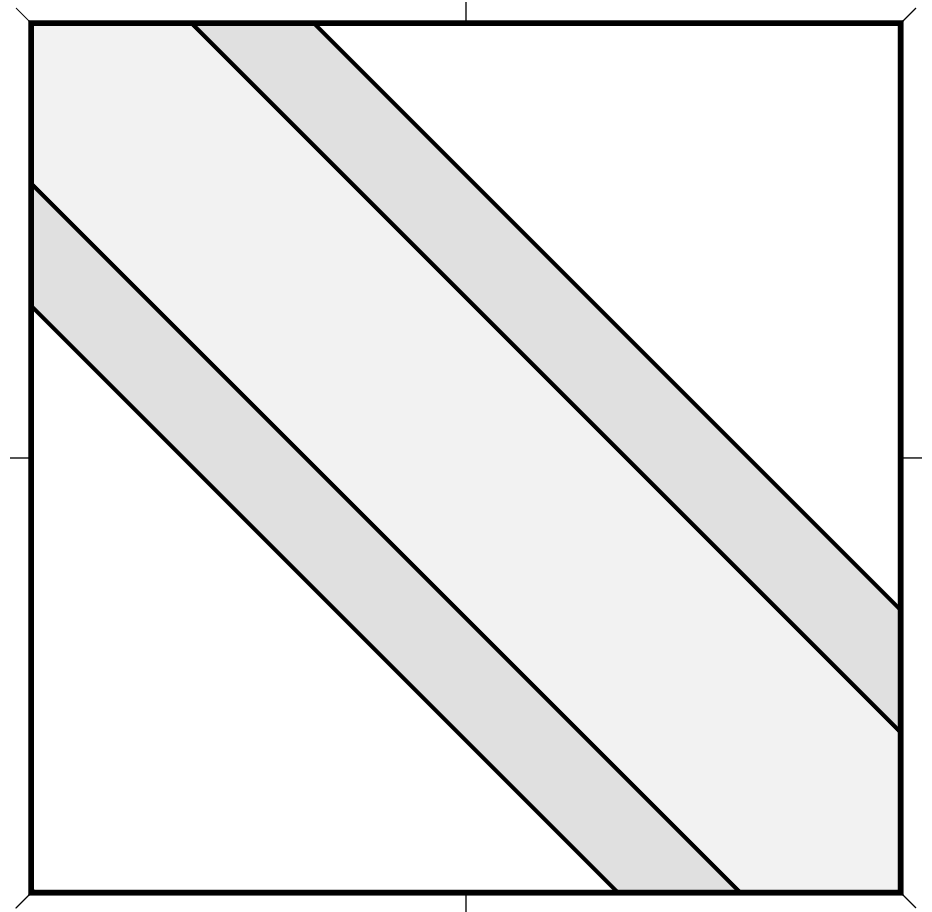
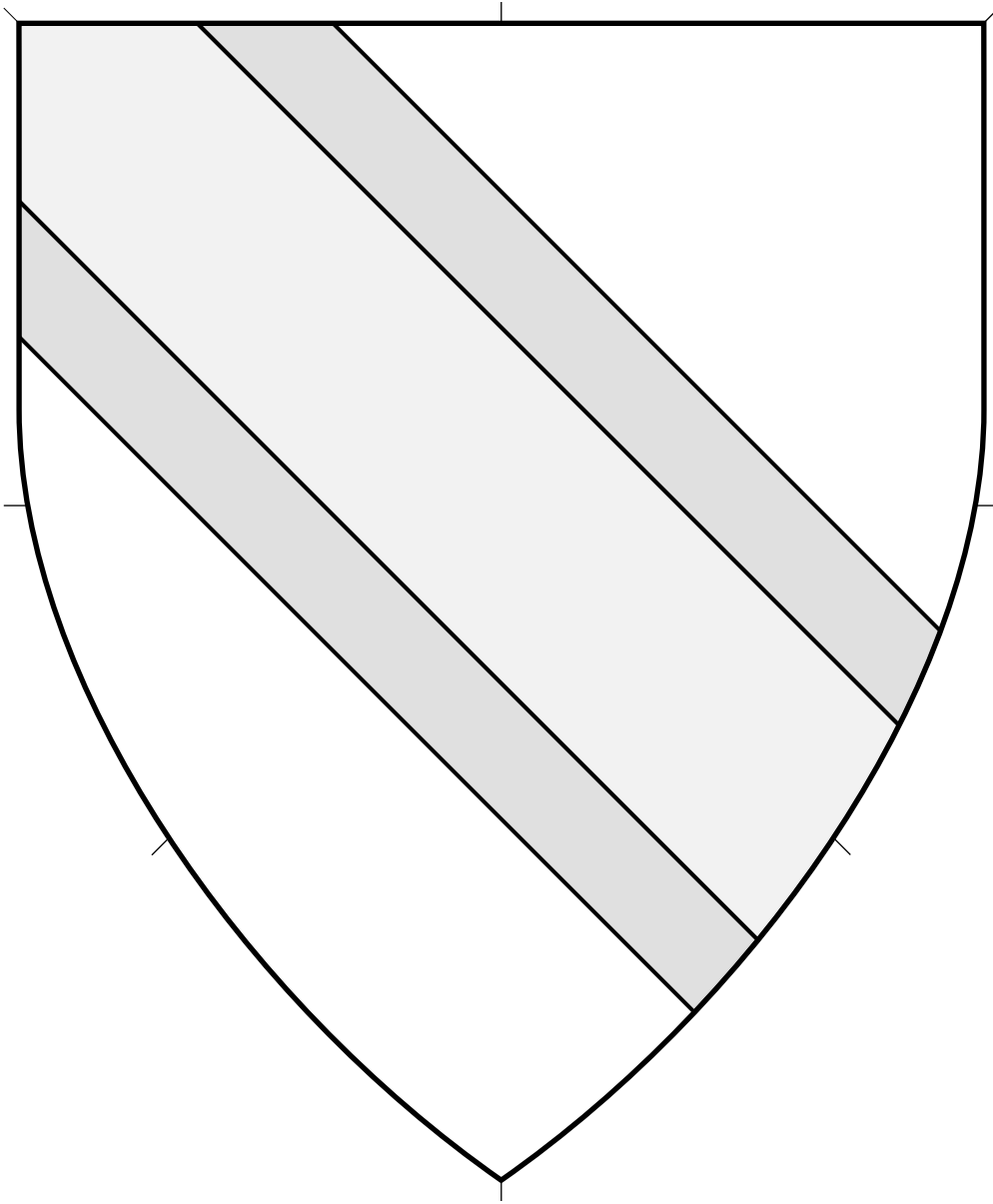

Central ordinary.

Source: English Arms A. Artist unknown. (Page 151.)

Bend Fimbriated (2) 4.82

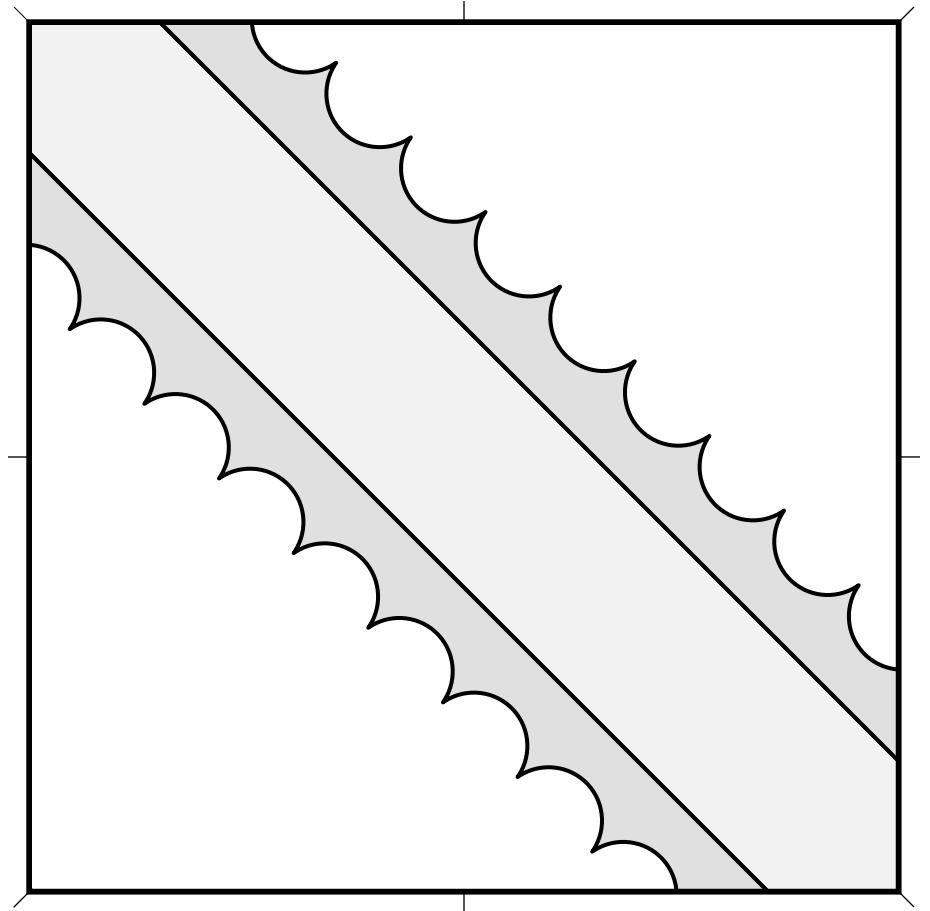
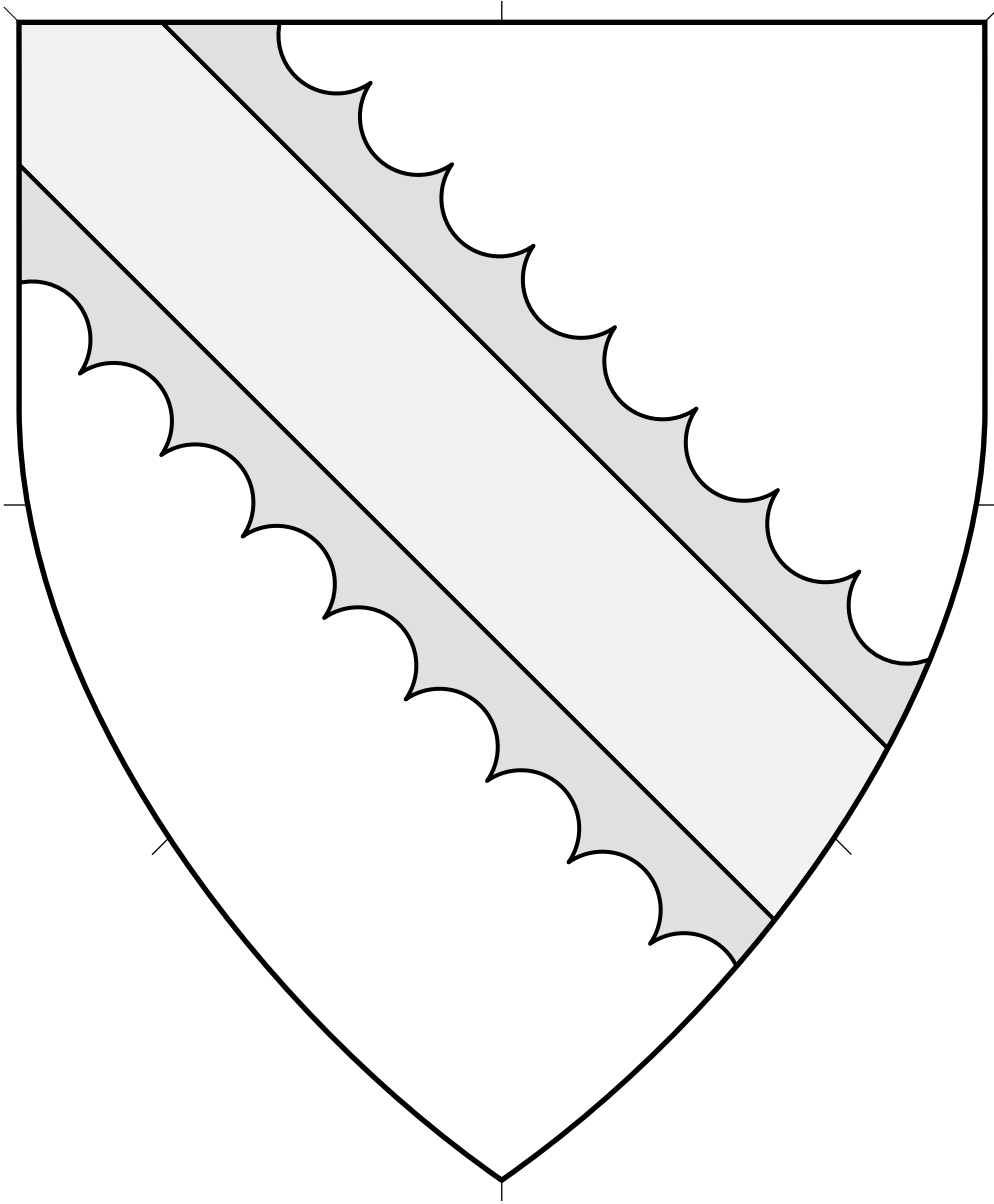

Central ordinary.

Bend Fimbriated Engrailed 4.83

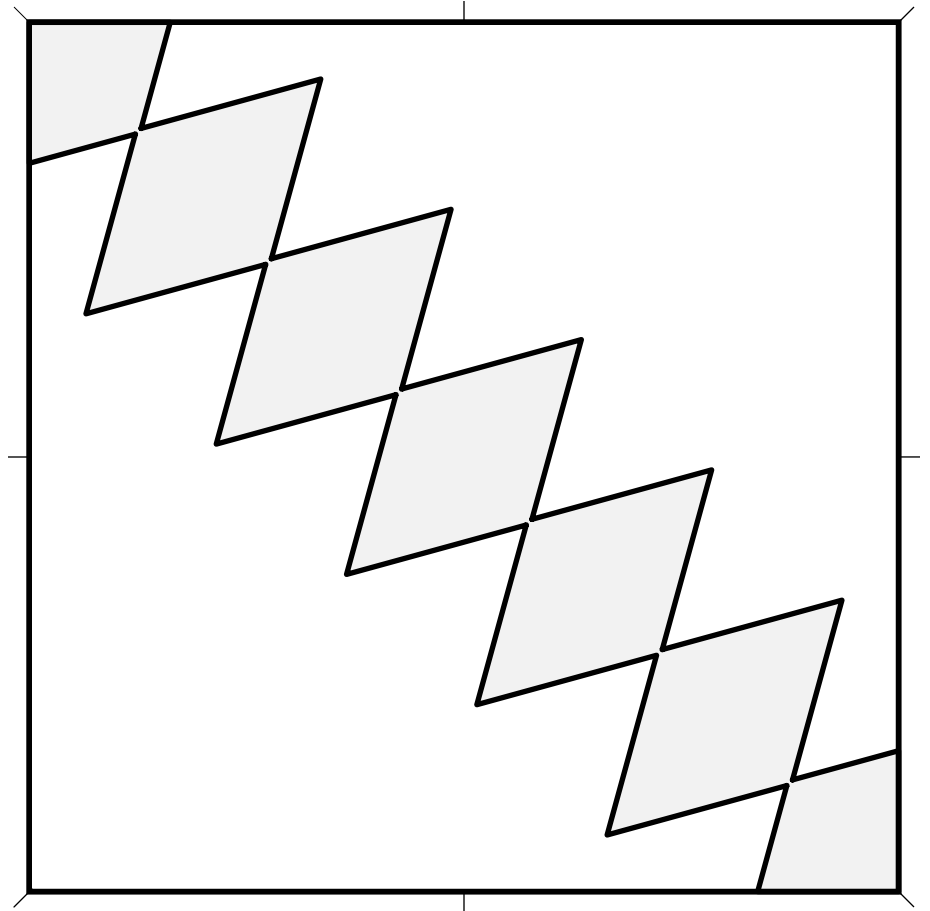
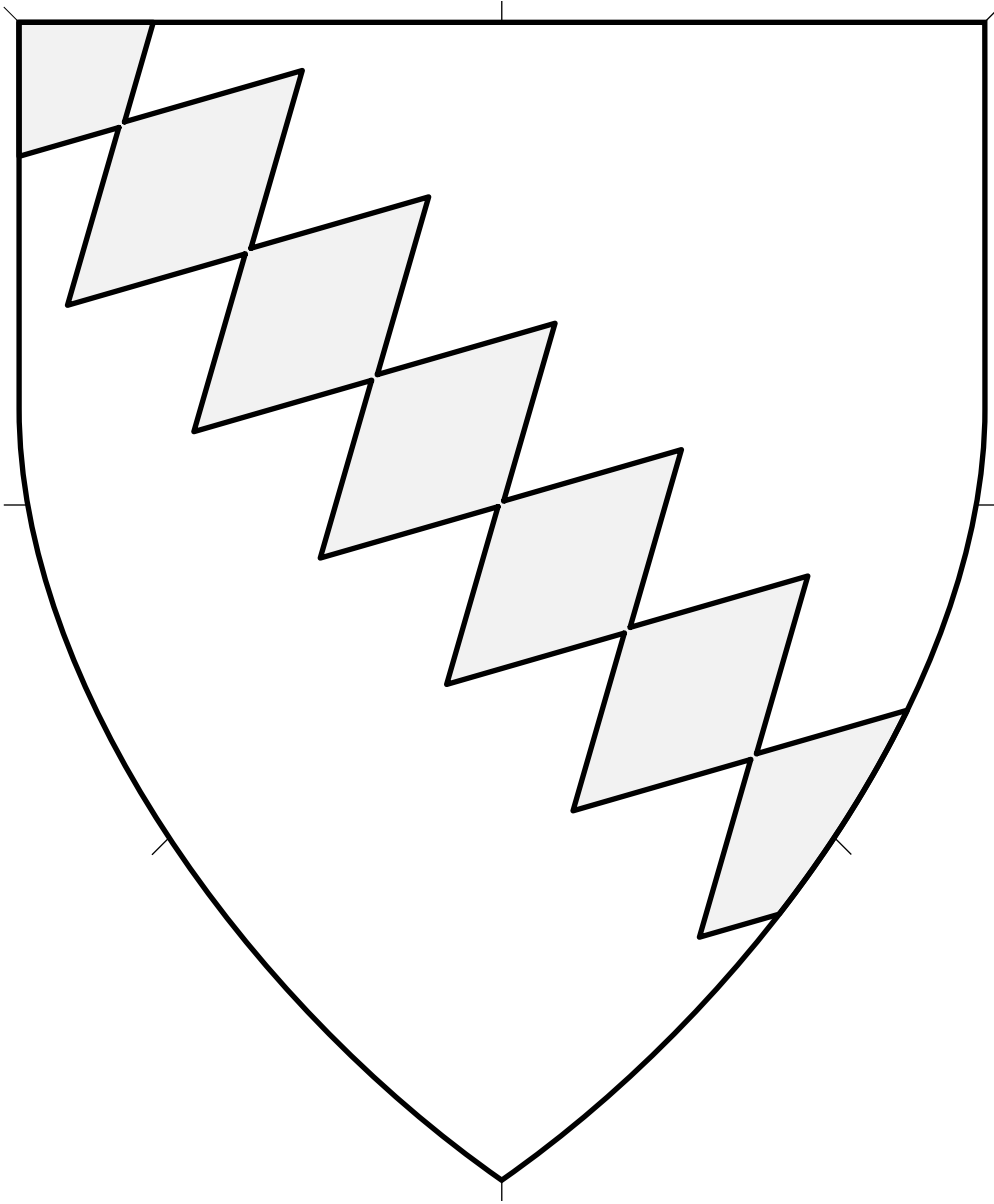

Central ordinary.

Source: Insignia Nobilium Veronensium, Vicentinorum. Artist unknown.
(From the arms of Ulmarana, folio 111.)

Bend Fusilly (1) 4.84

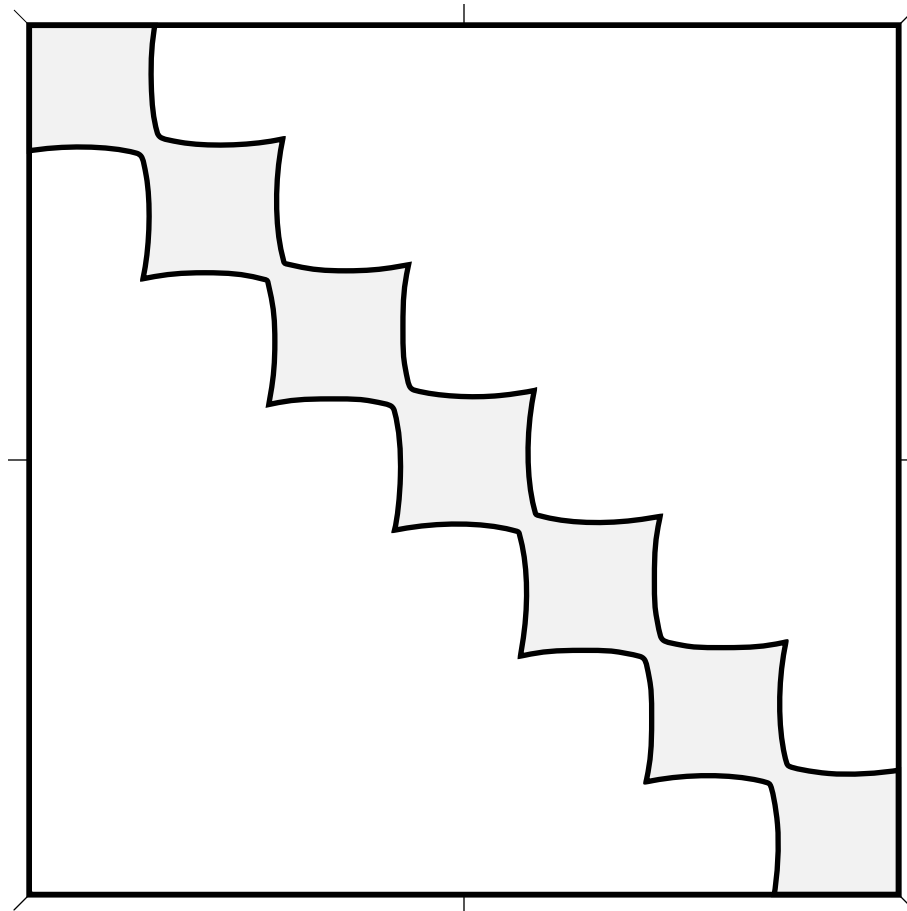
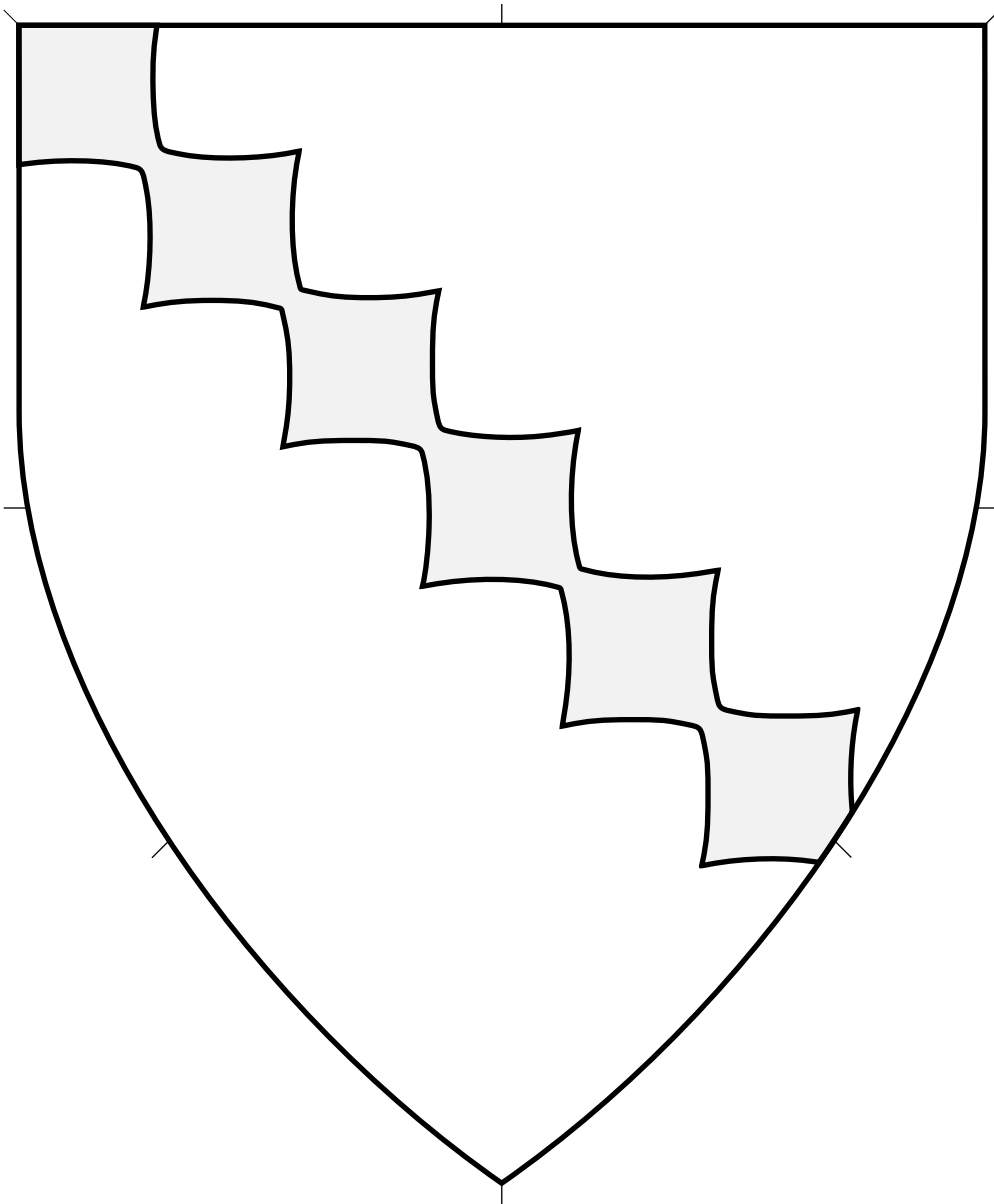

Central ordinary.

Source: Armorial de Gelre. Artist: Claes Heinenzoon. (Page 221.)
Adapted by Mathghamhain Ua Ruadháin.

Bend Fusilly (2) 4.85

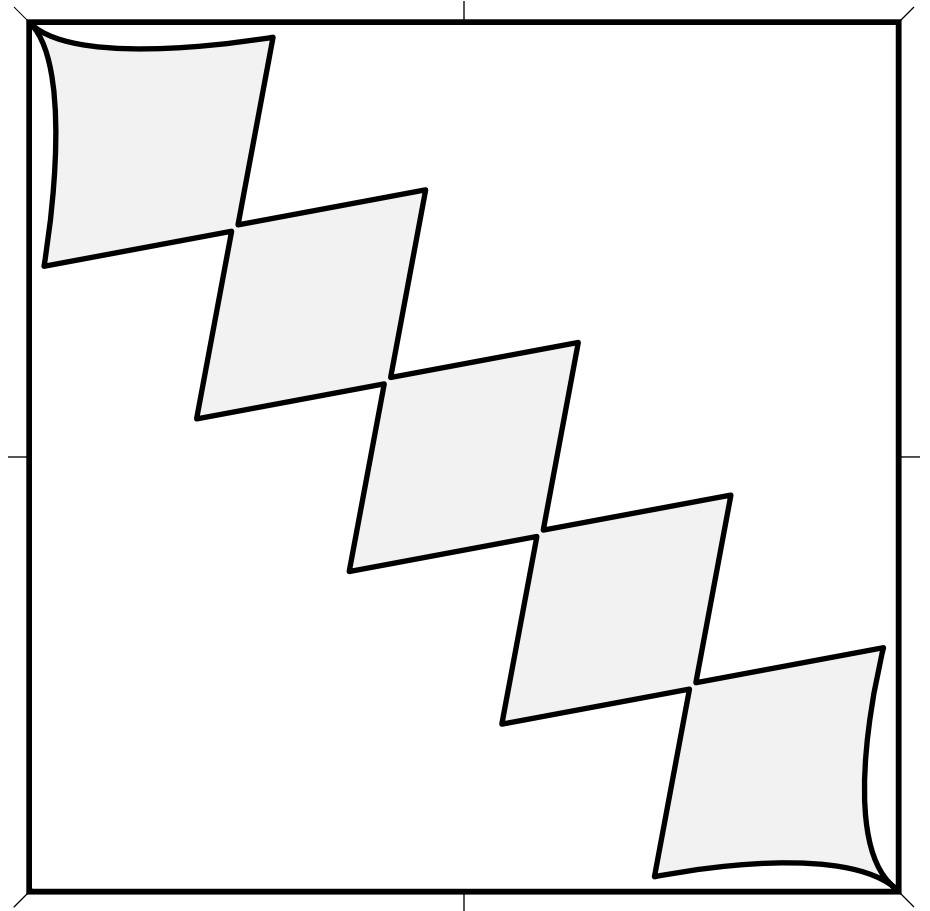
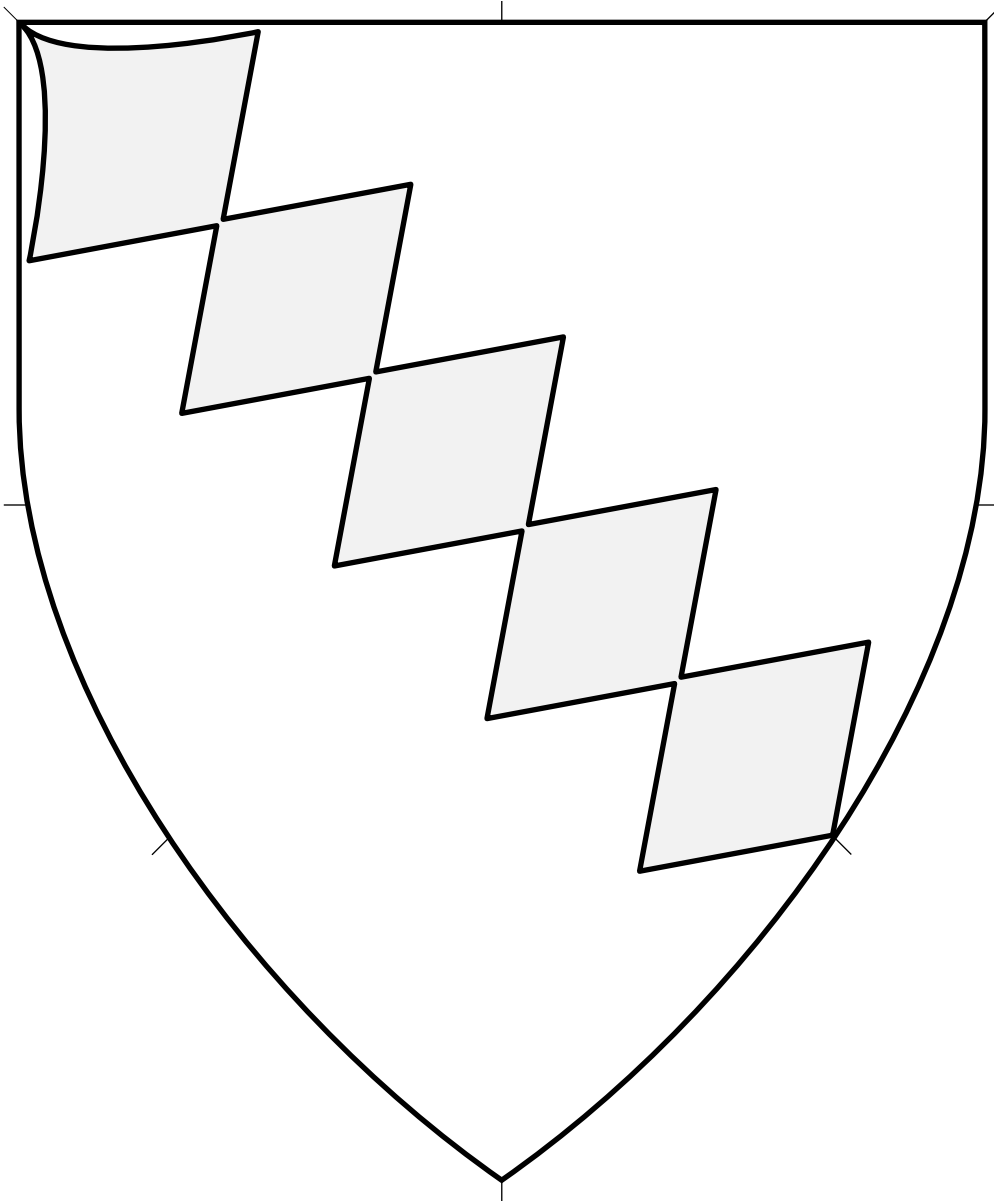

Central ordinary.

Source: BnF MS Fr 5240. Artist unknown. (Folio 18r.)
Adapted by Mathghamhain Ua Ruadháin.

Bend Fusilly (3) 4.86

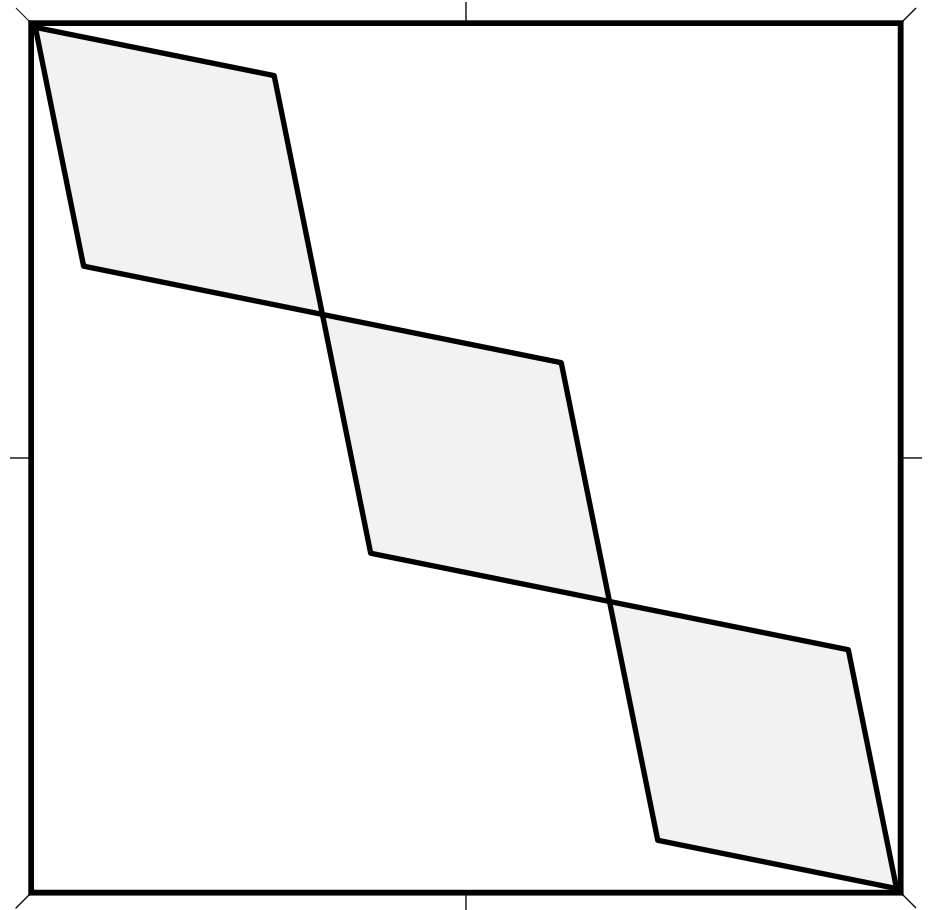
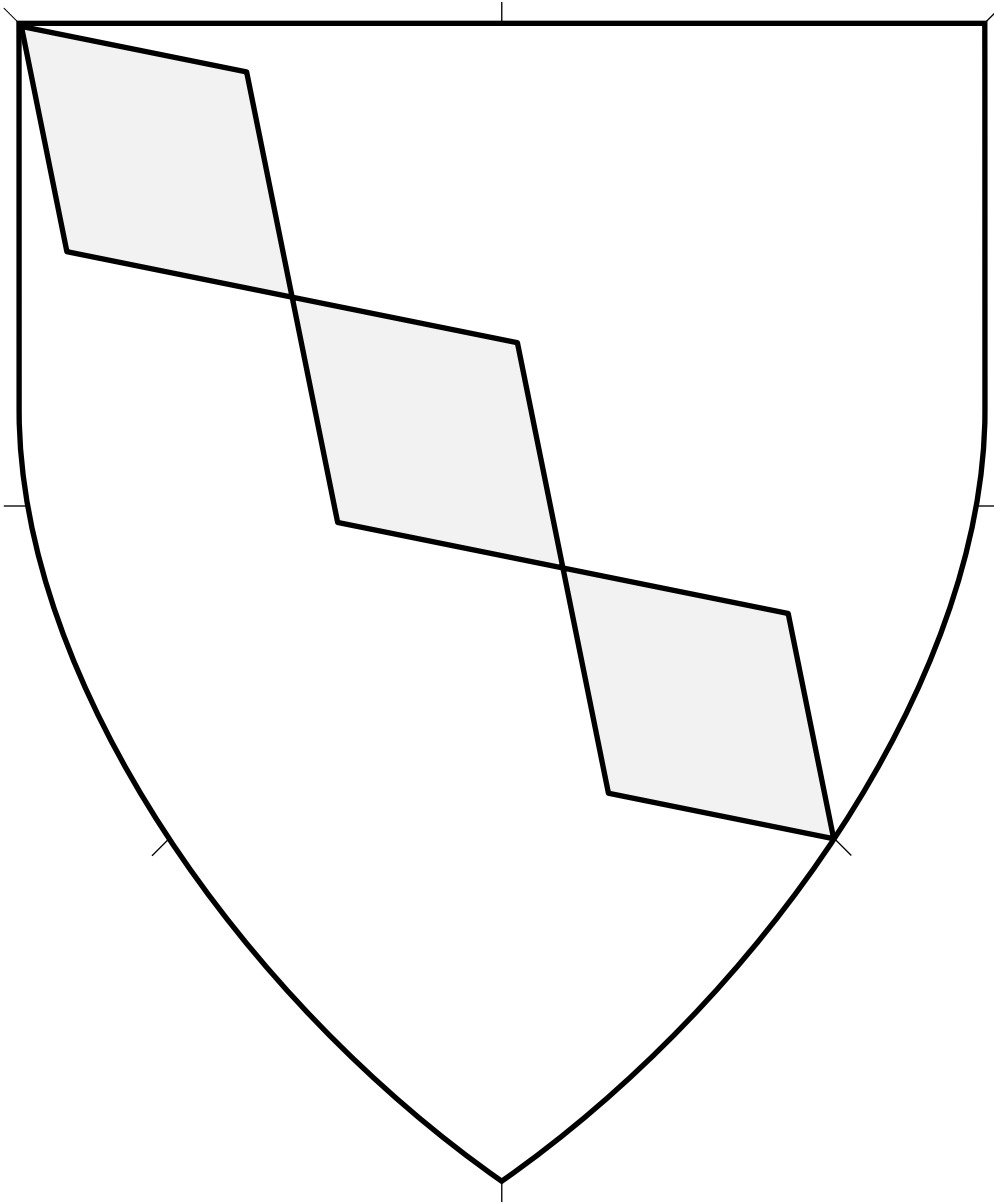

Central ordinary.

Source: Wappenbuch der Arlberg-Bruderschaft.
Artist: Vigil Raber. (Page 837.)

Bend Fusilly (4) 4.87

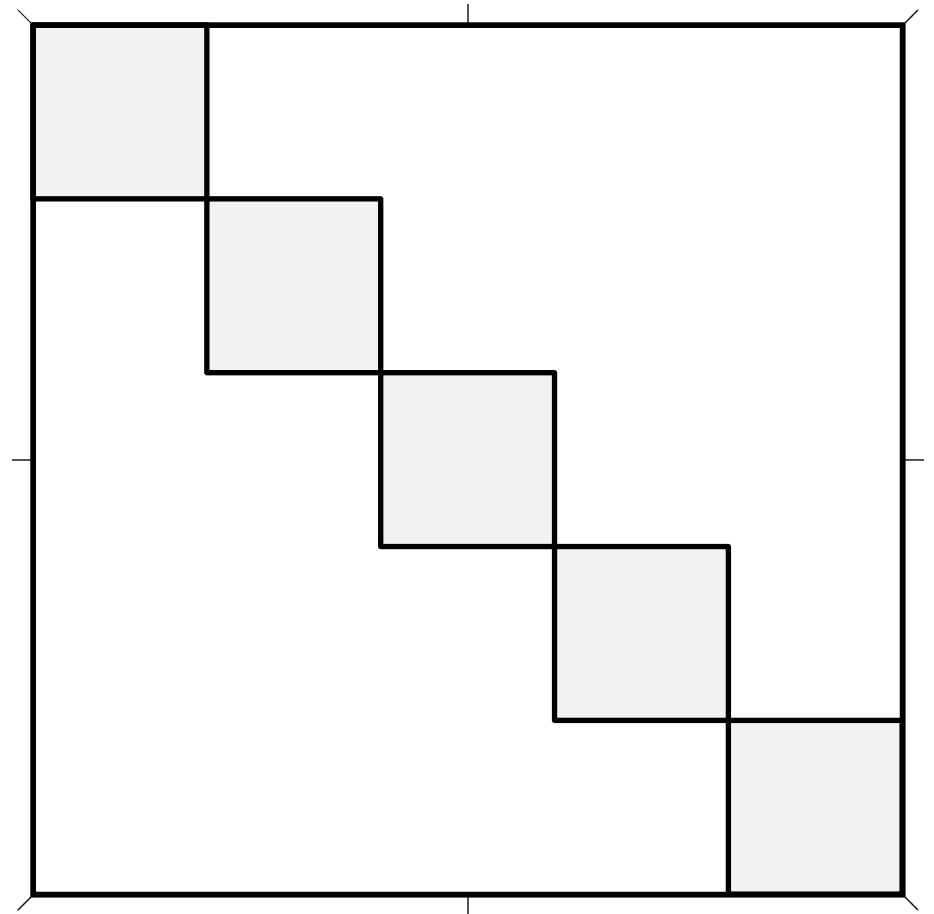
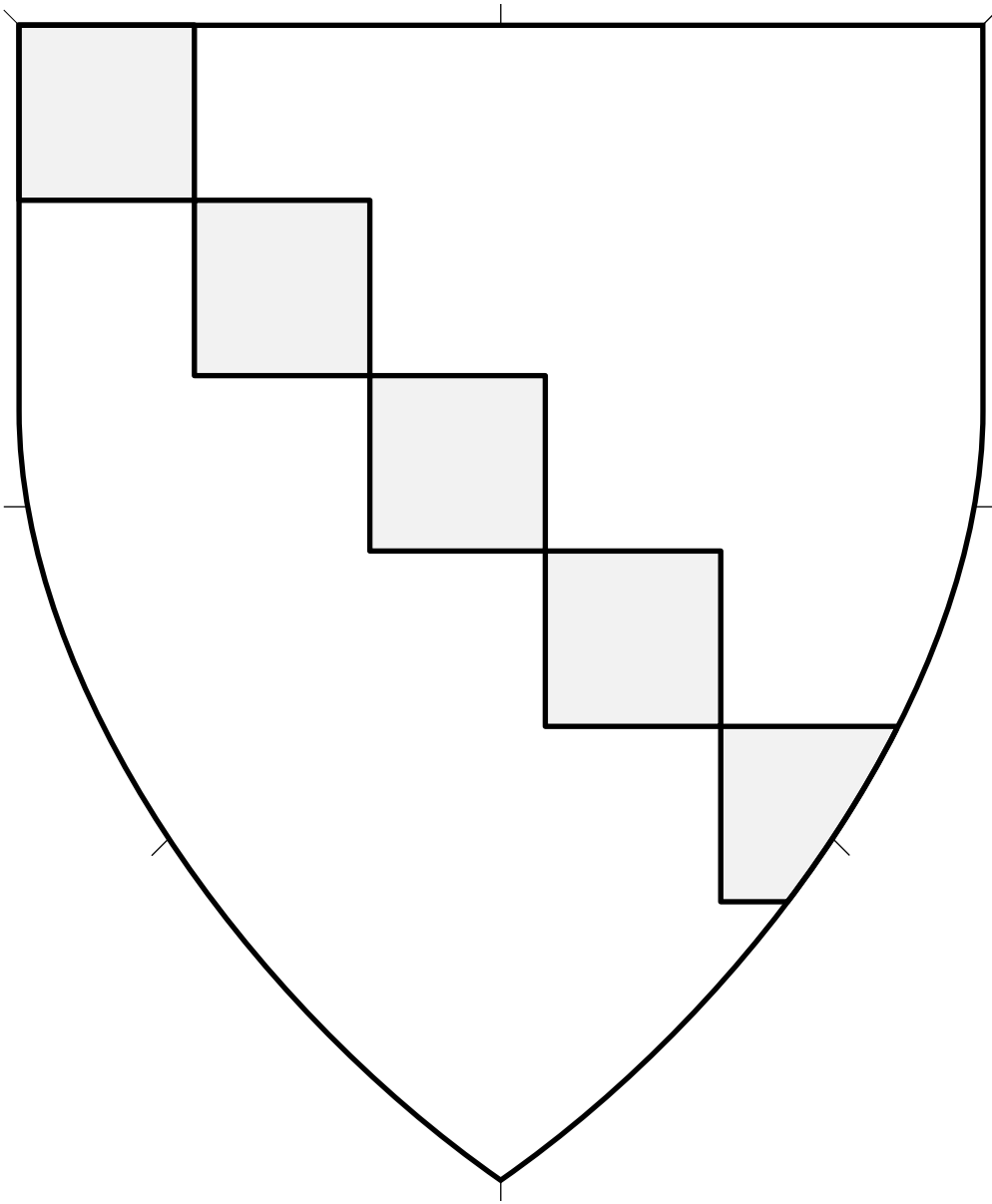

Central ordinary.

Source: BnF MS Allemand 304. Artist unknown. (Page 570.)

Bend Fusilly (5) 4.88

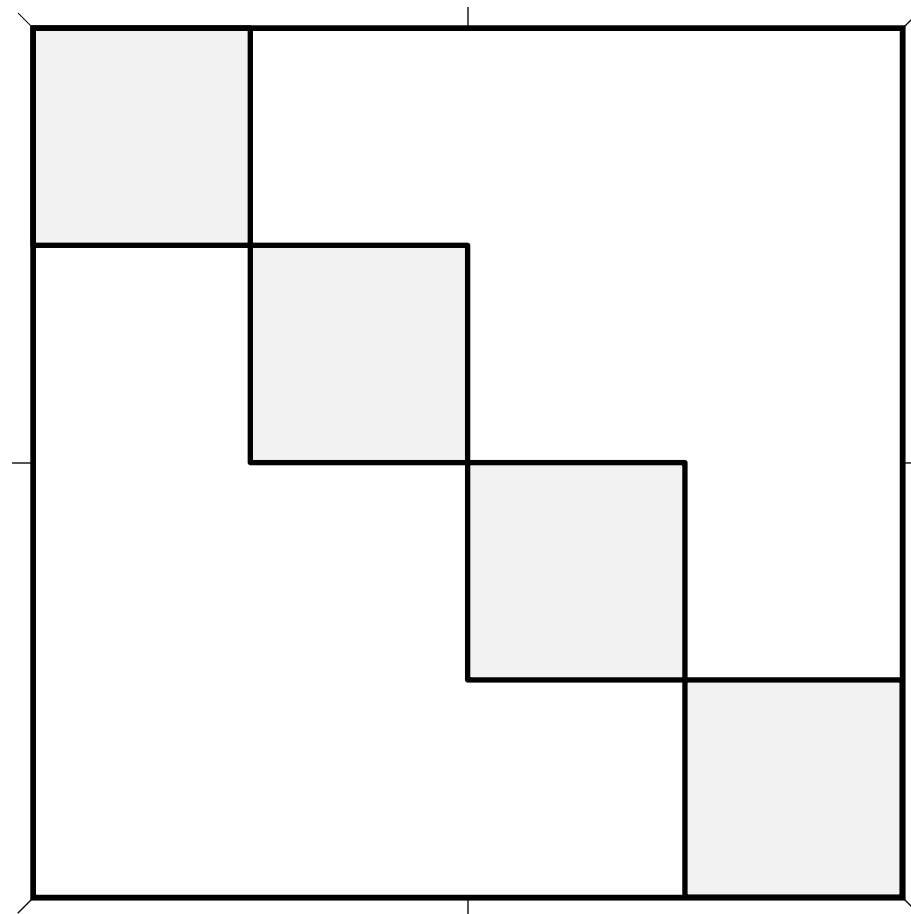
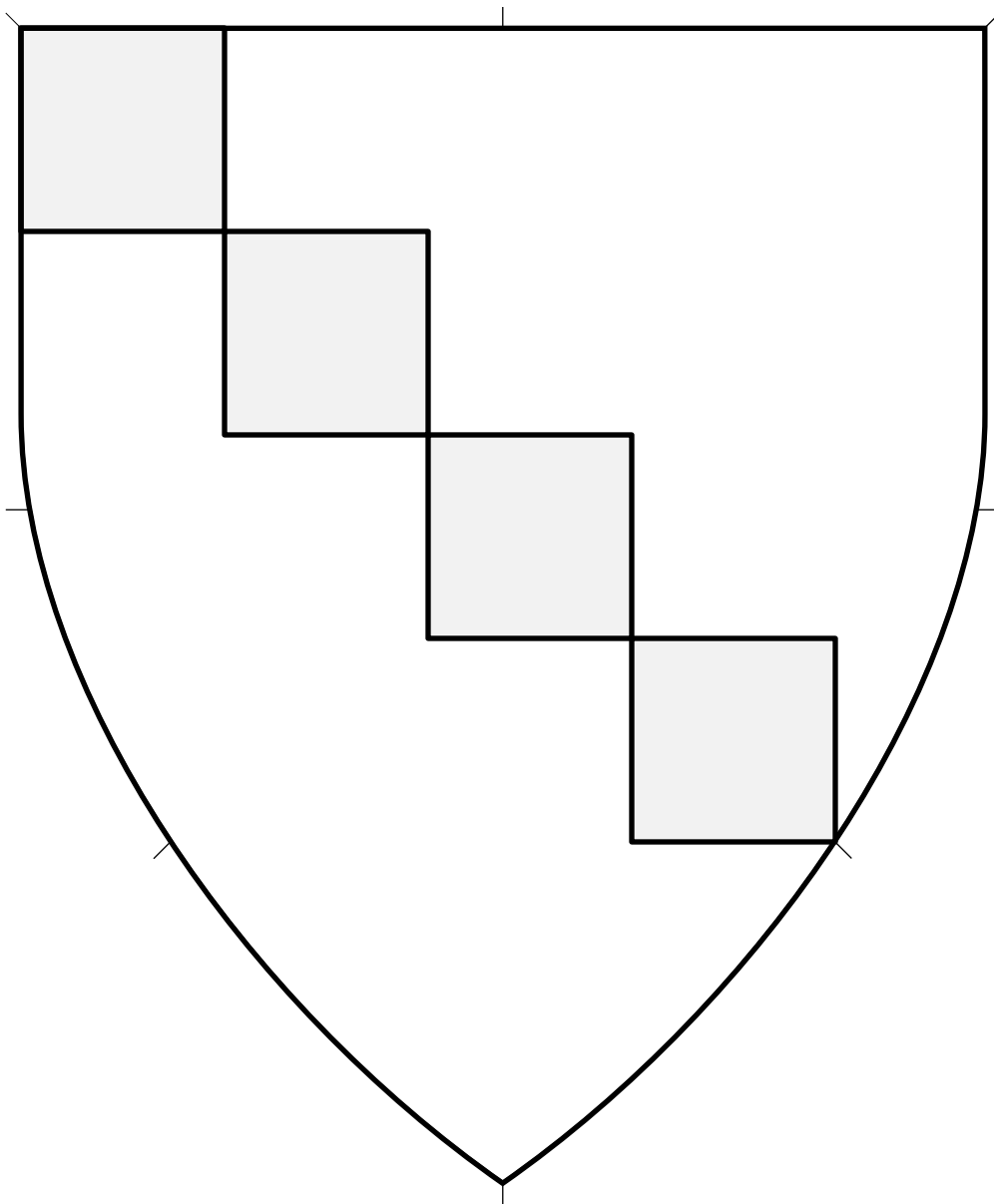

Central ordinary.

Source: BnF MS Allemand 304. Artist unknown. (Page 439.)

Bend Fusilly (6) 4.89

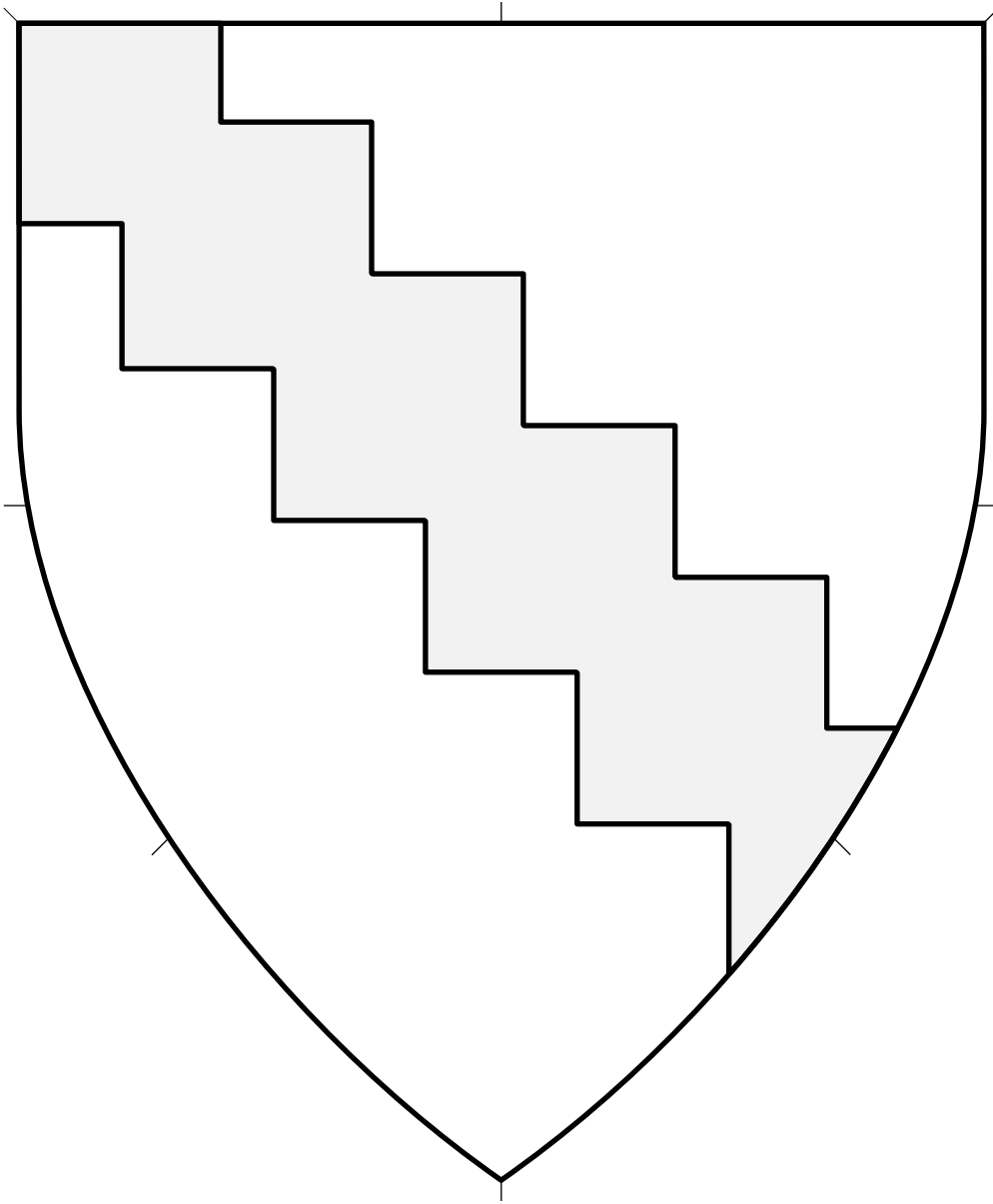

Central ordinary.

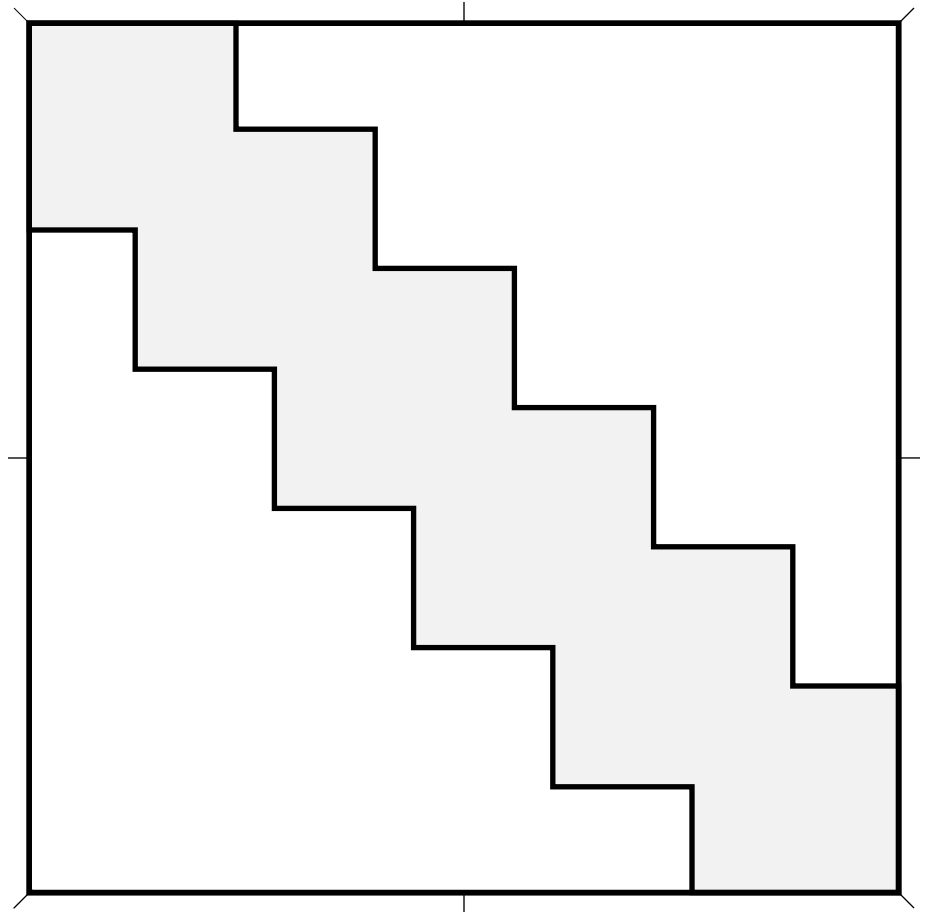

Bend Indented 4.90

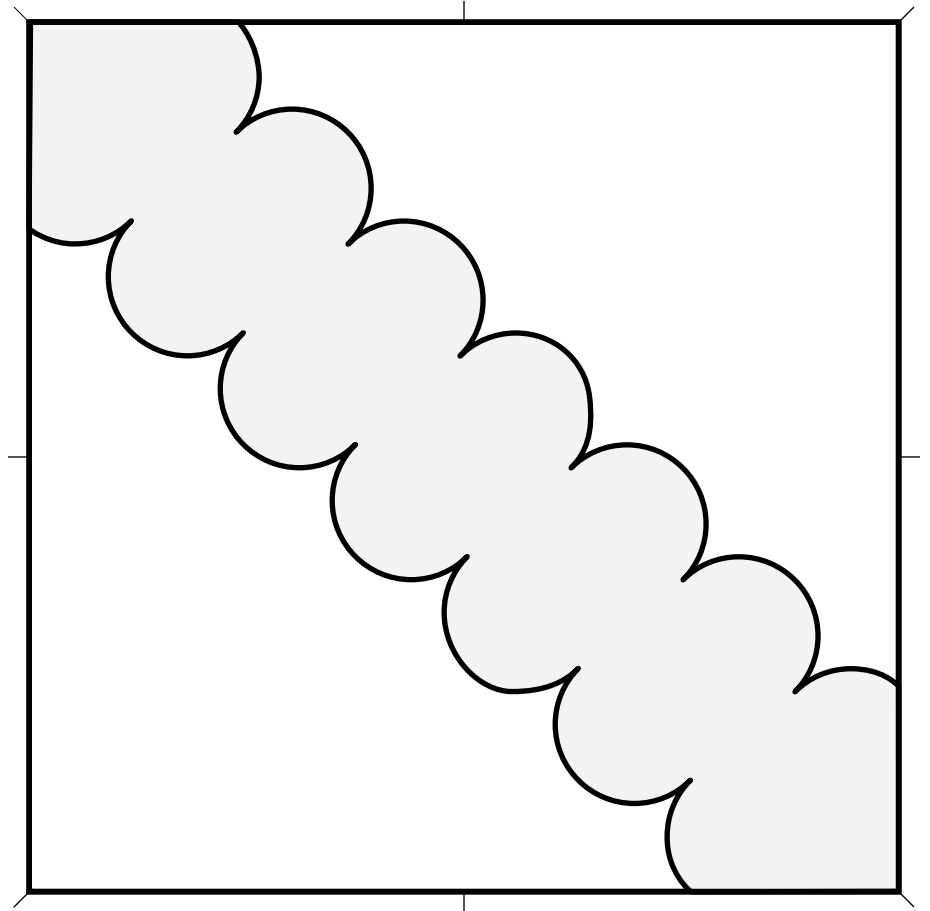
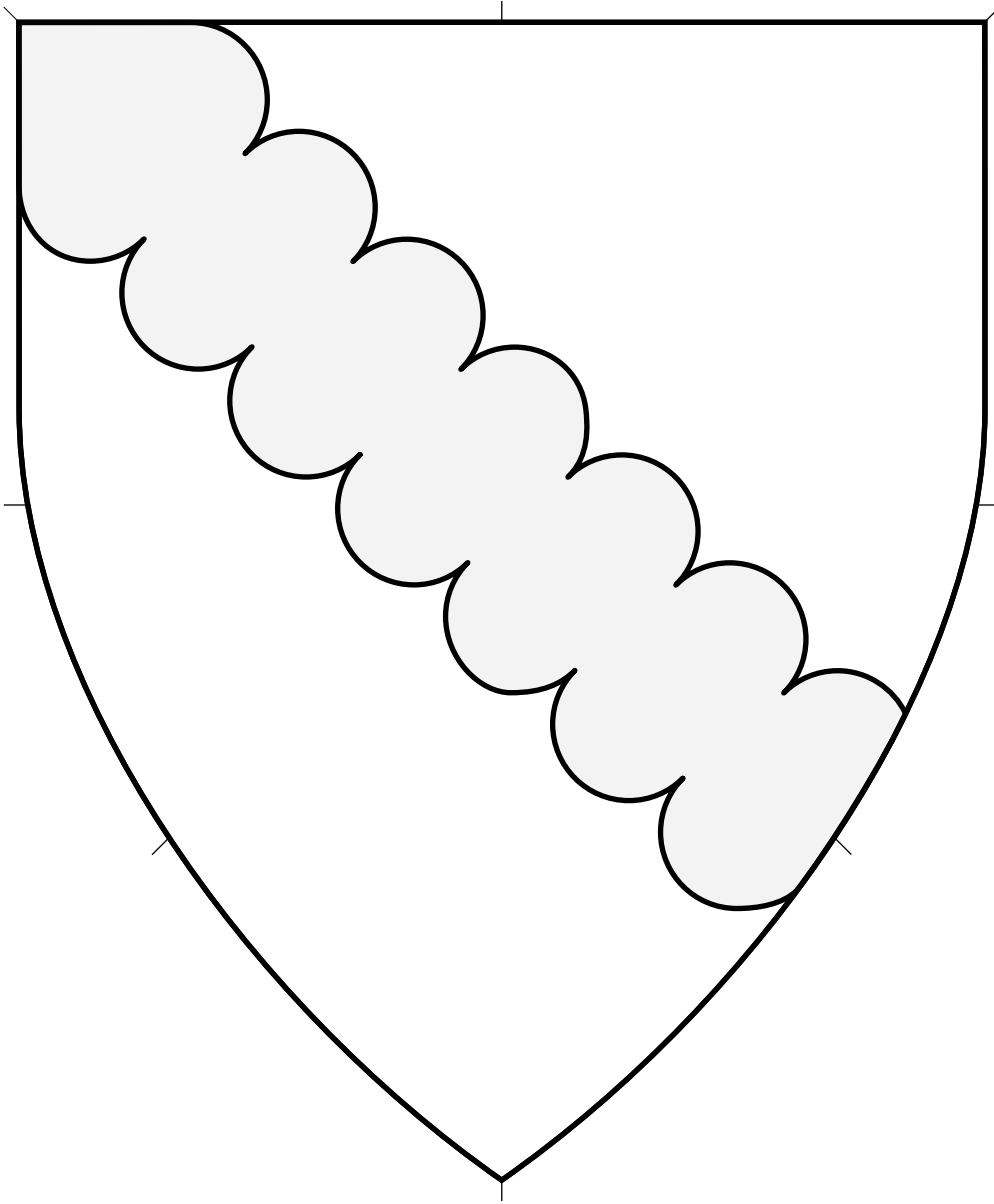

Central ordinary.

Artist: Elionora inghean Ui Cheallaigh.
Adapted by Mathghamhain Ua Ruadháin.

Bend Inverted 4.91

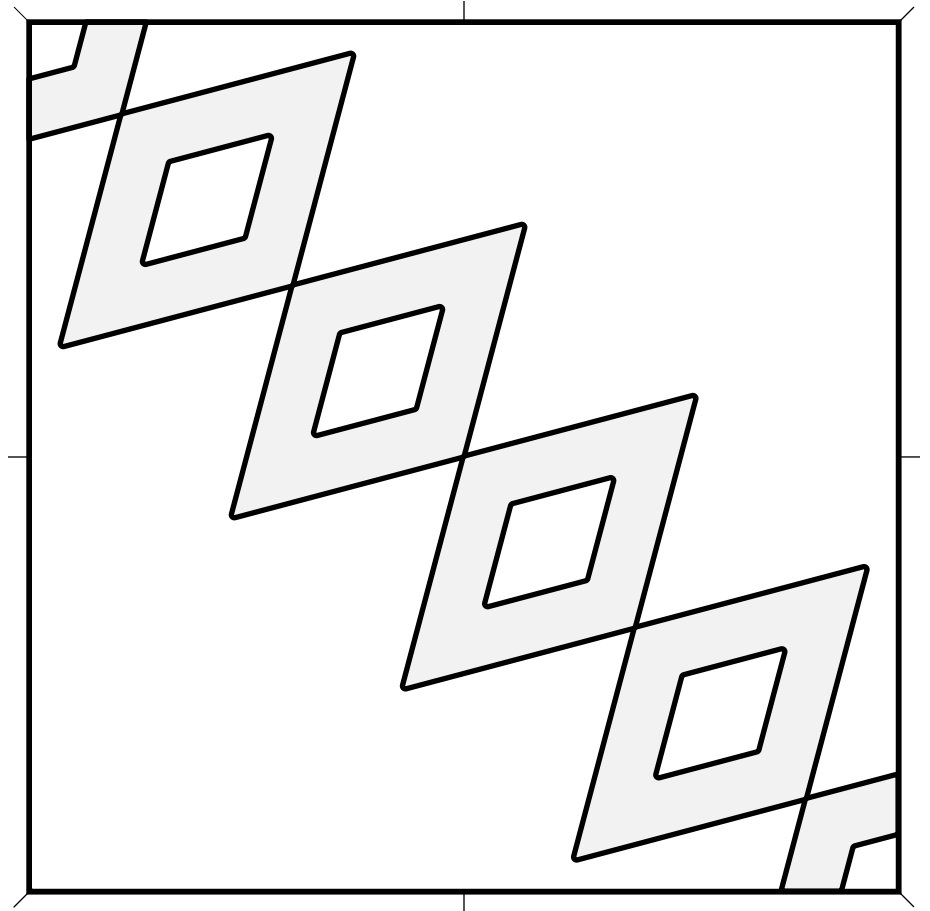
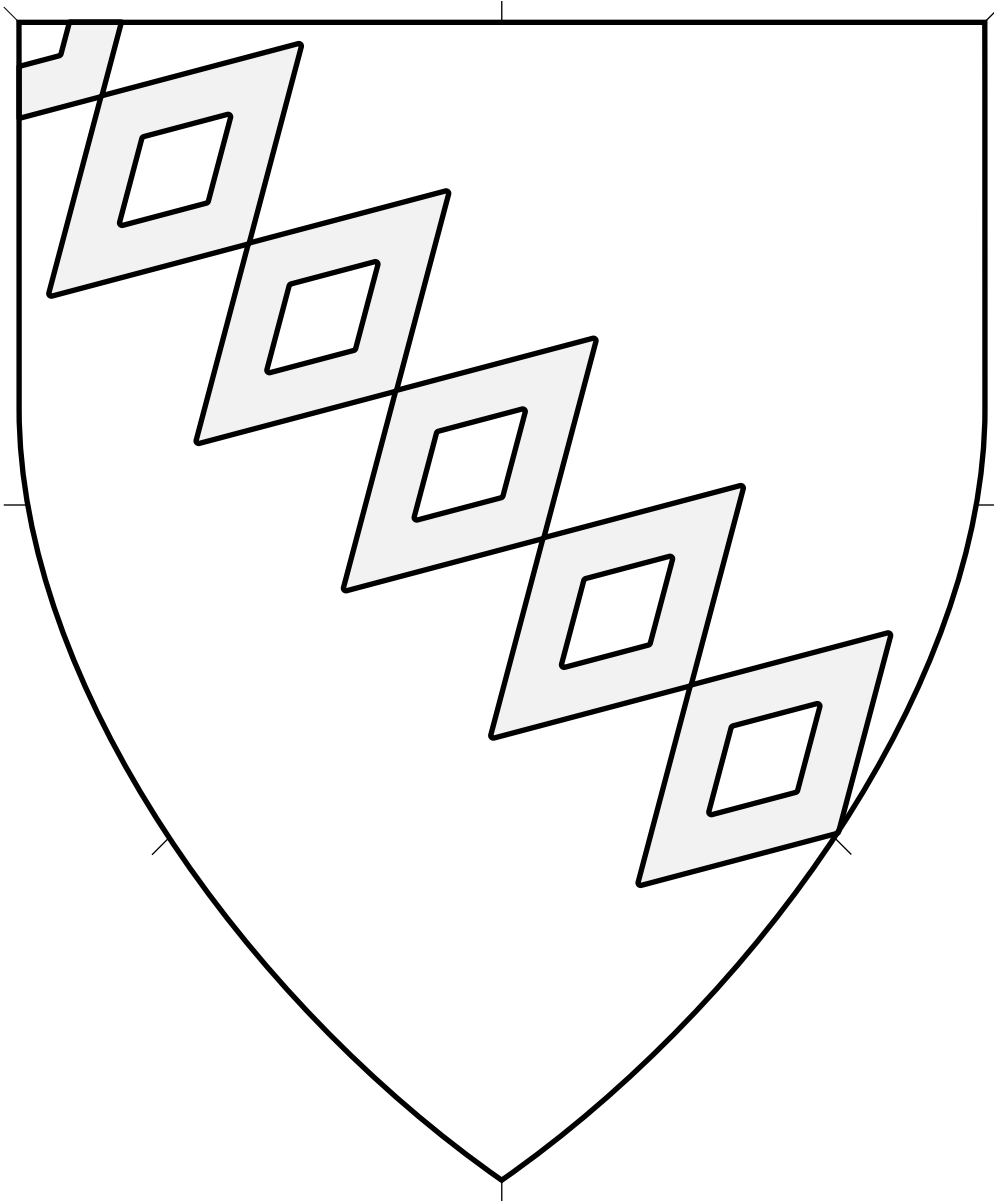

Central ordinary.

Bend Masculy • 4.92

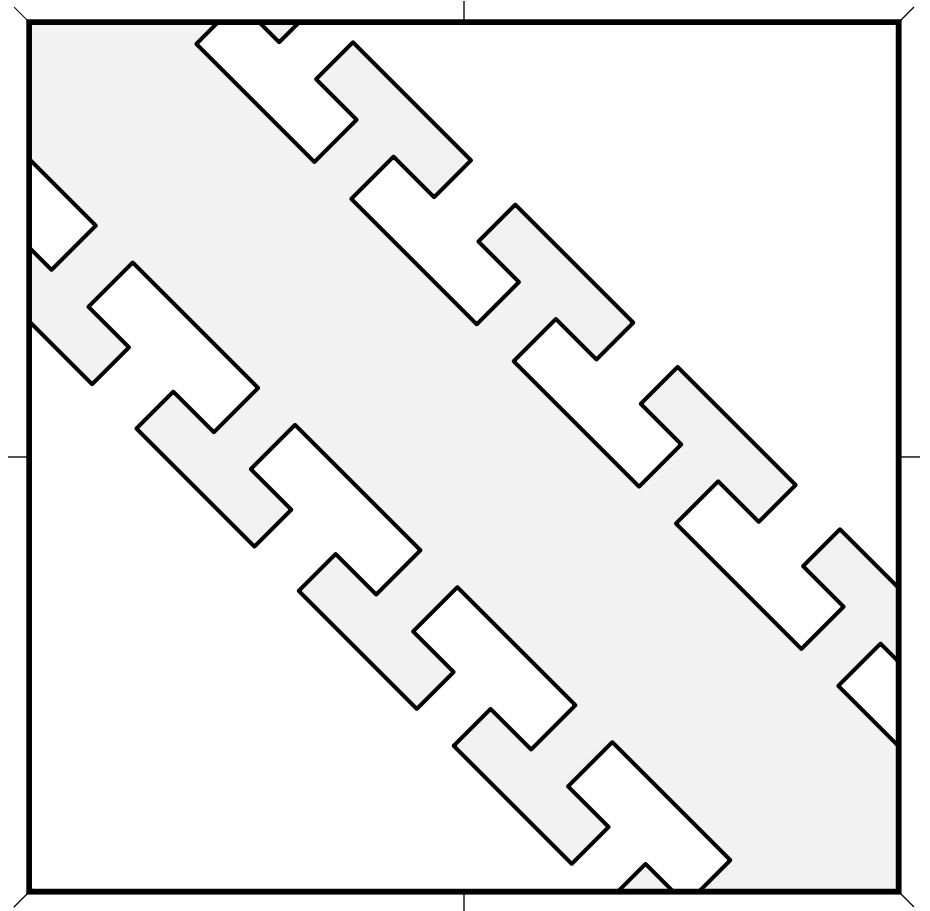
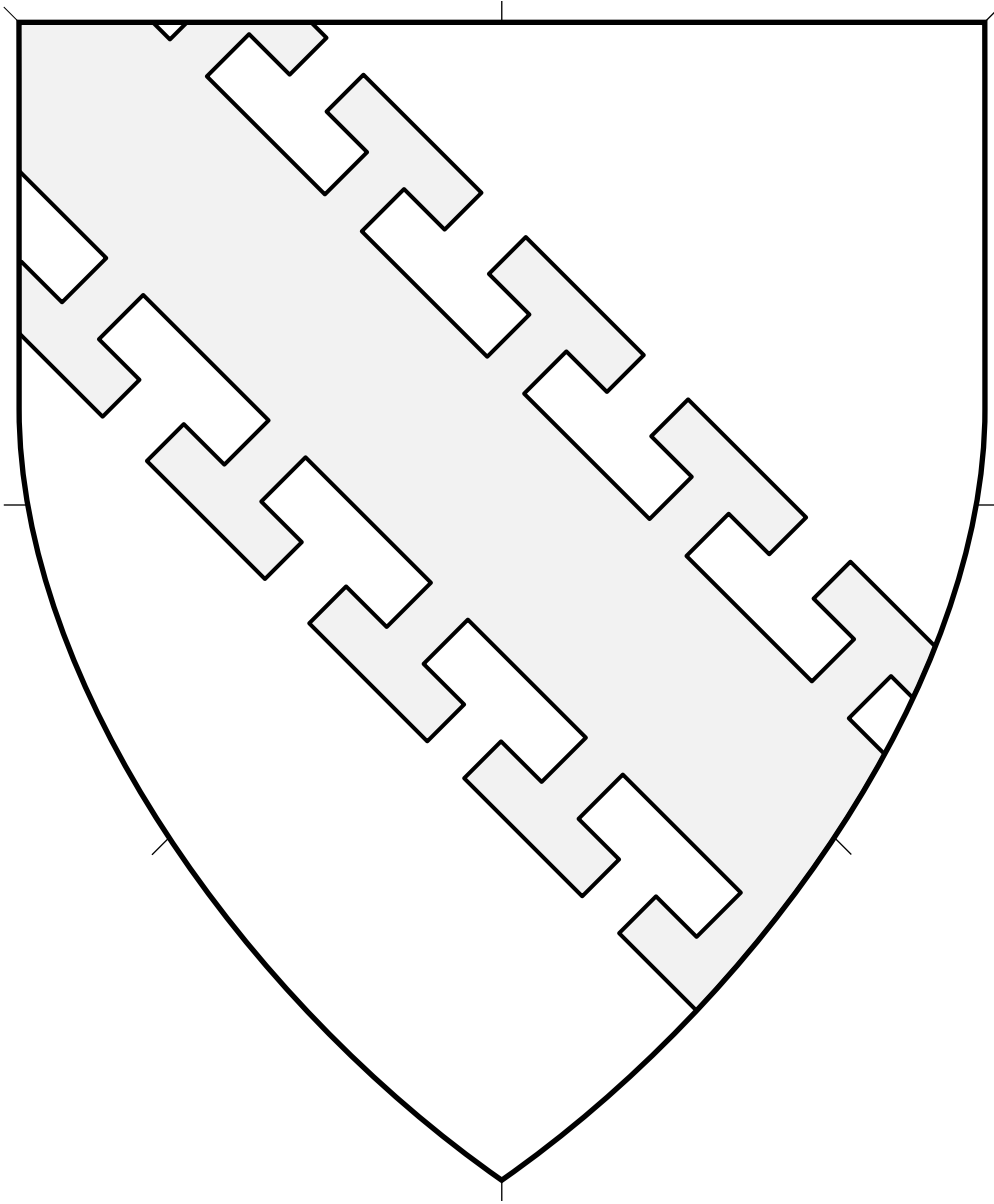

Central ordinary.

Bend Potenty 4.93

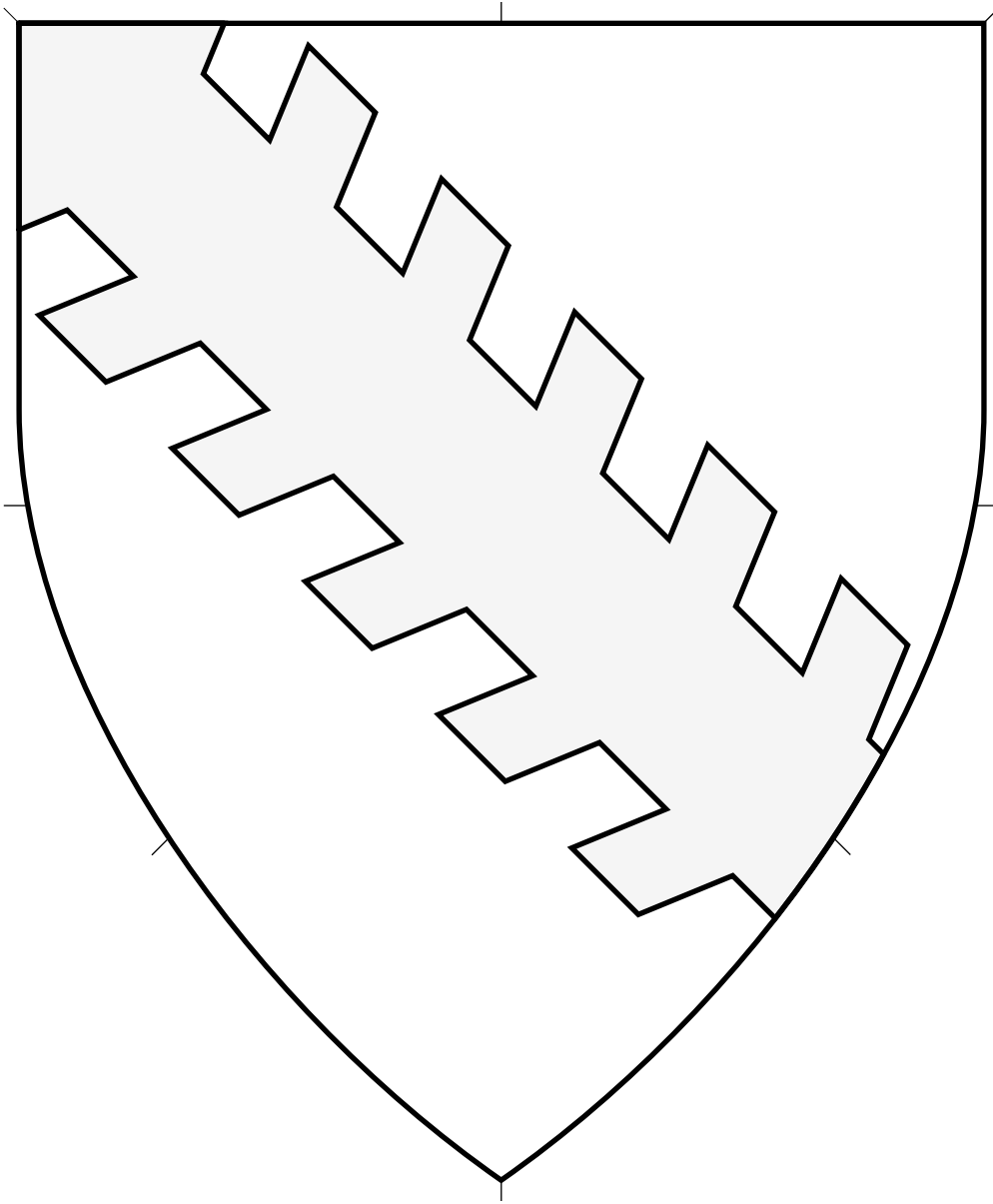

Central ordinary.

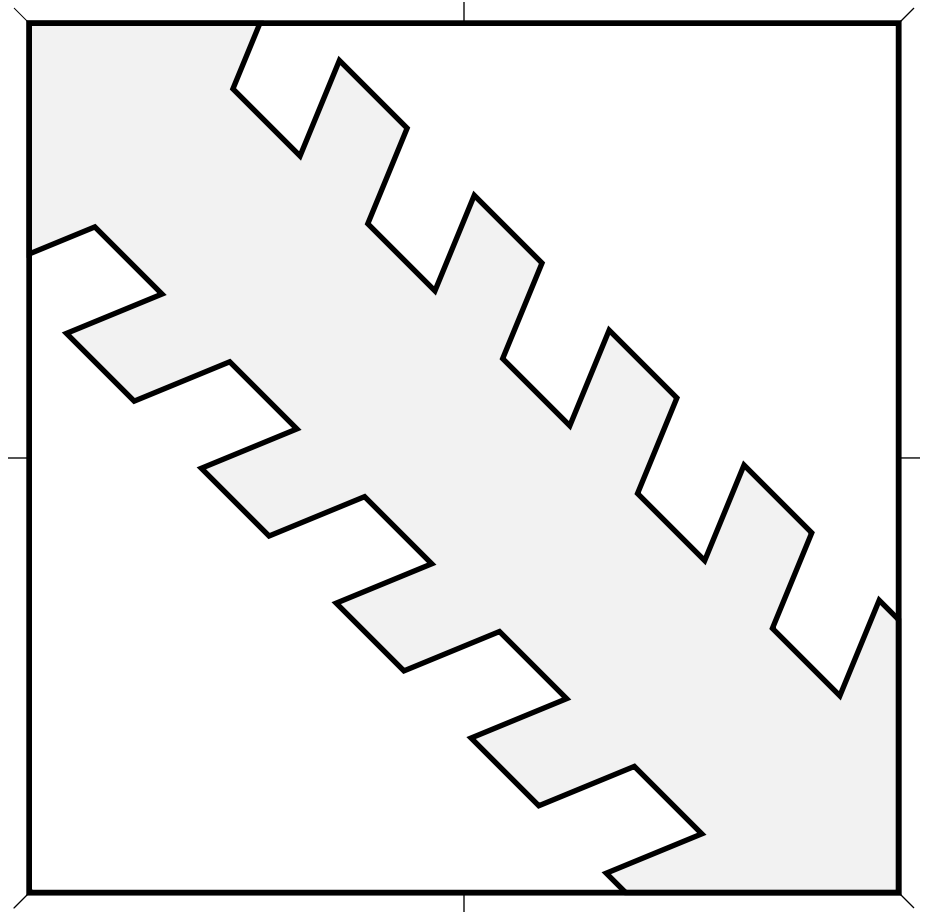

Bend Raguly (1) 4.94

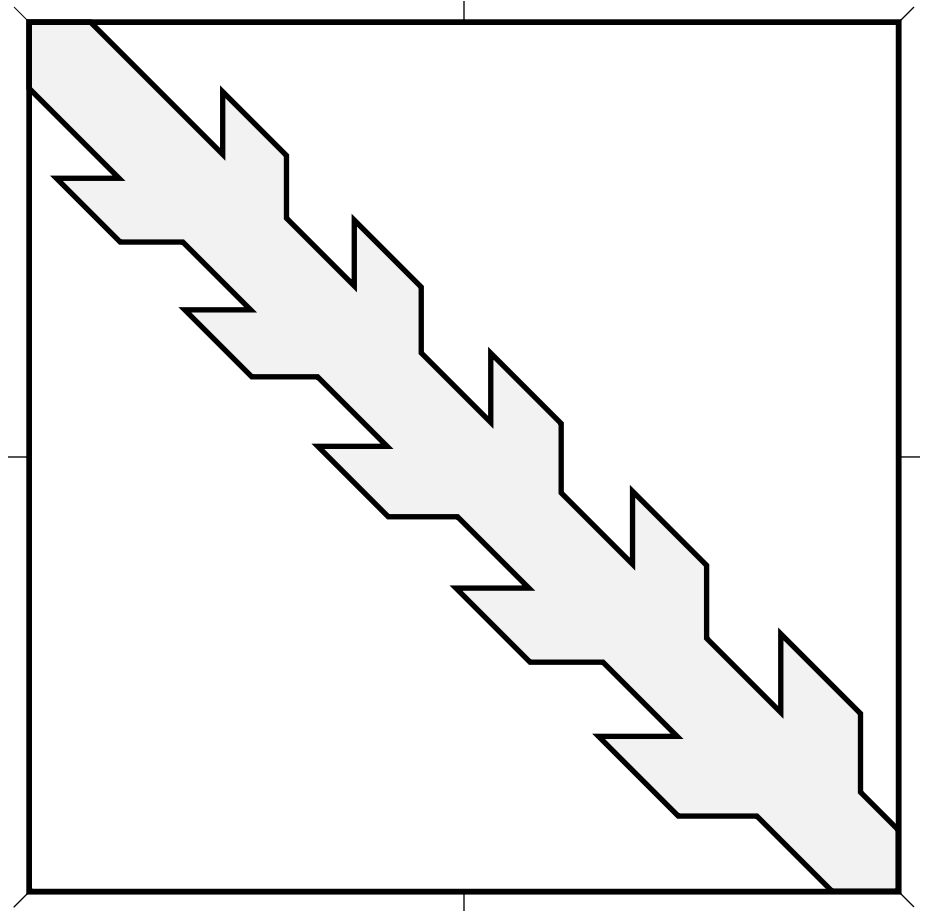
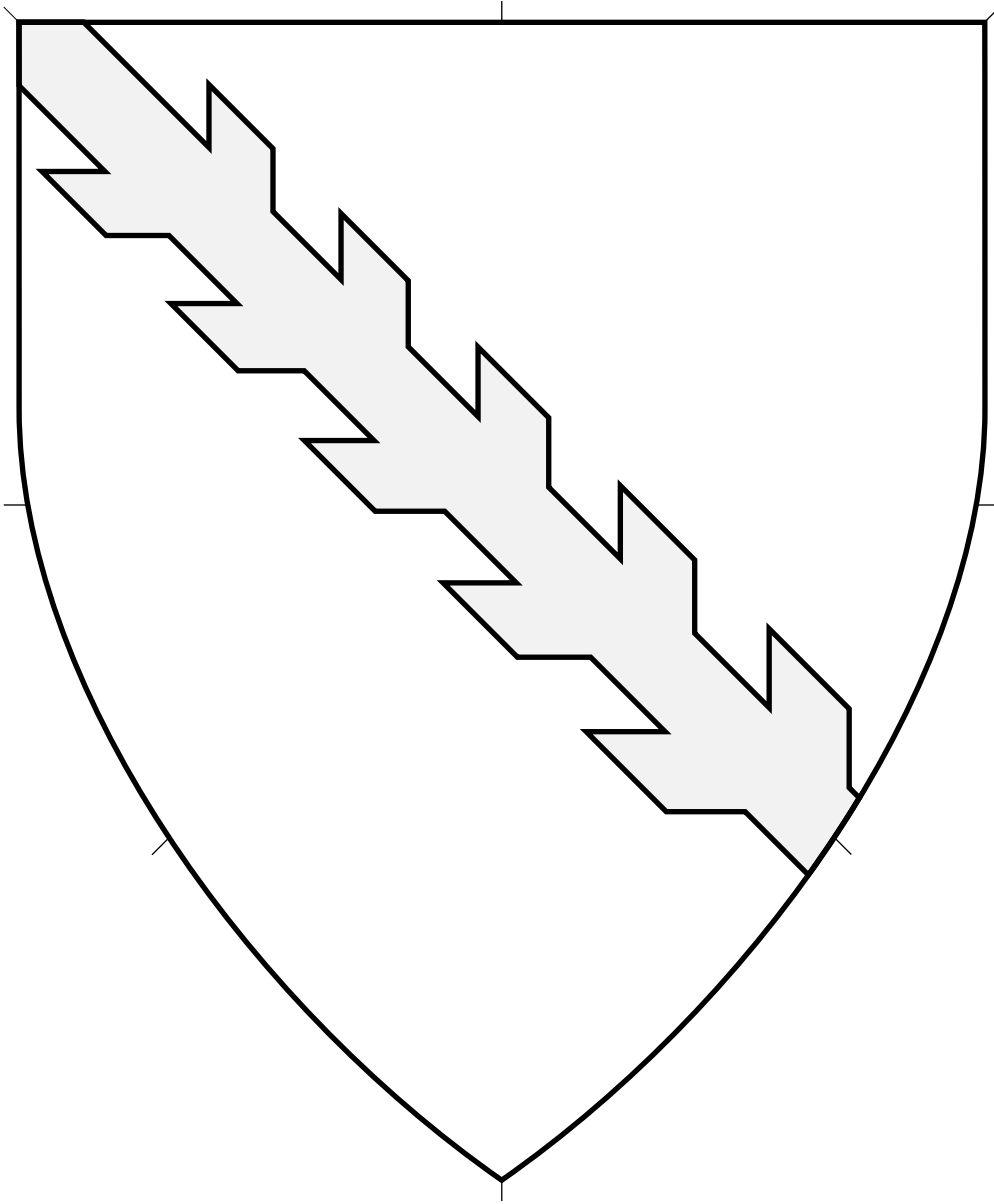

Central ordinary.

Source: Ehrenspiegel des Hauses Österreich.
Artist unknown. (Page 579. Adapted from a saltire raguly.)

Bend Raguly (2) 4.95

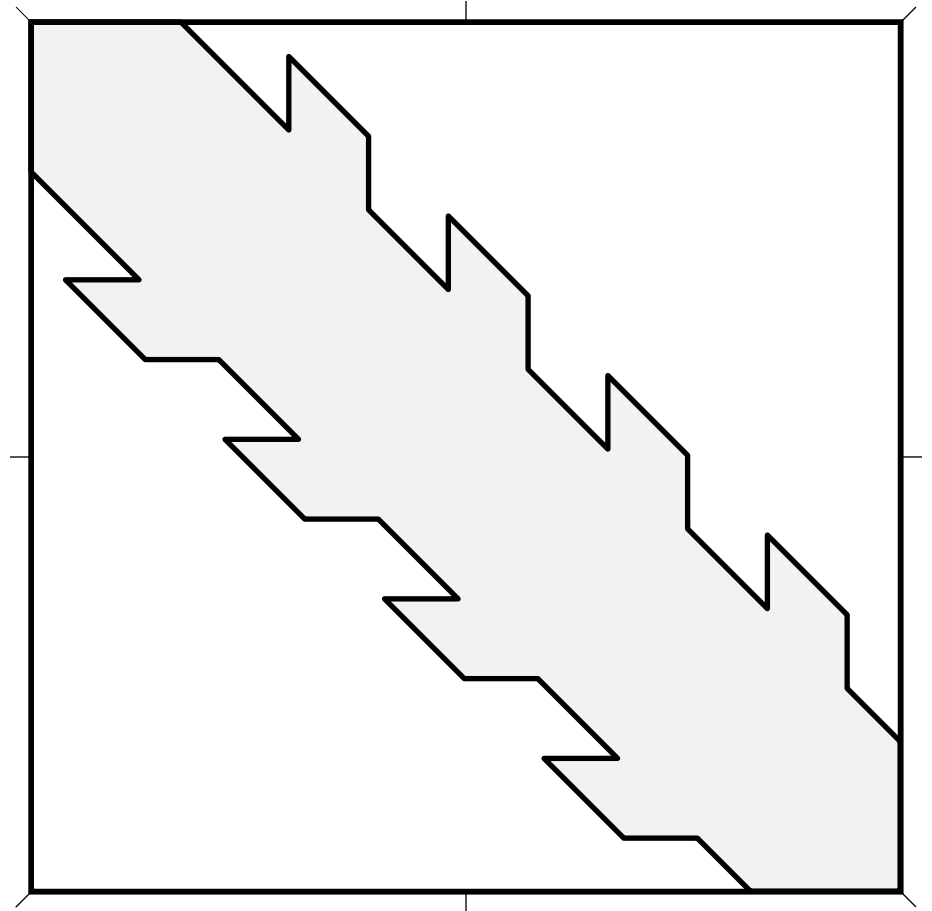
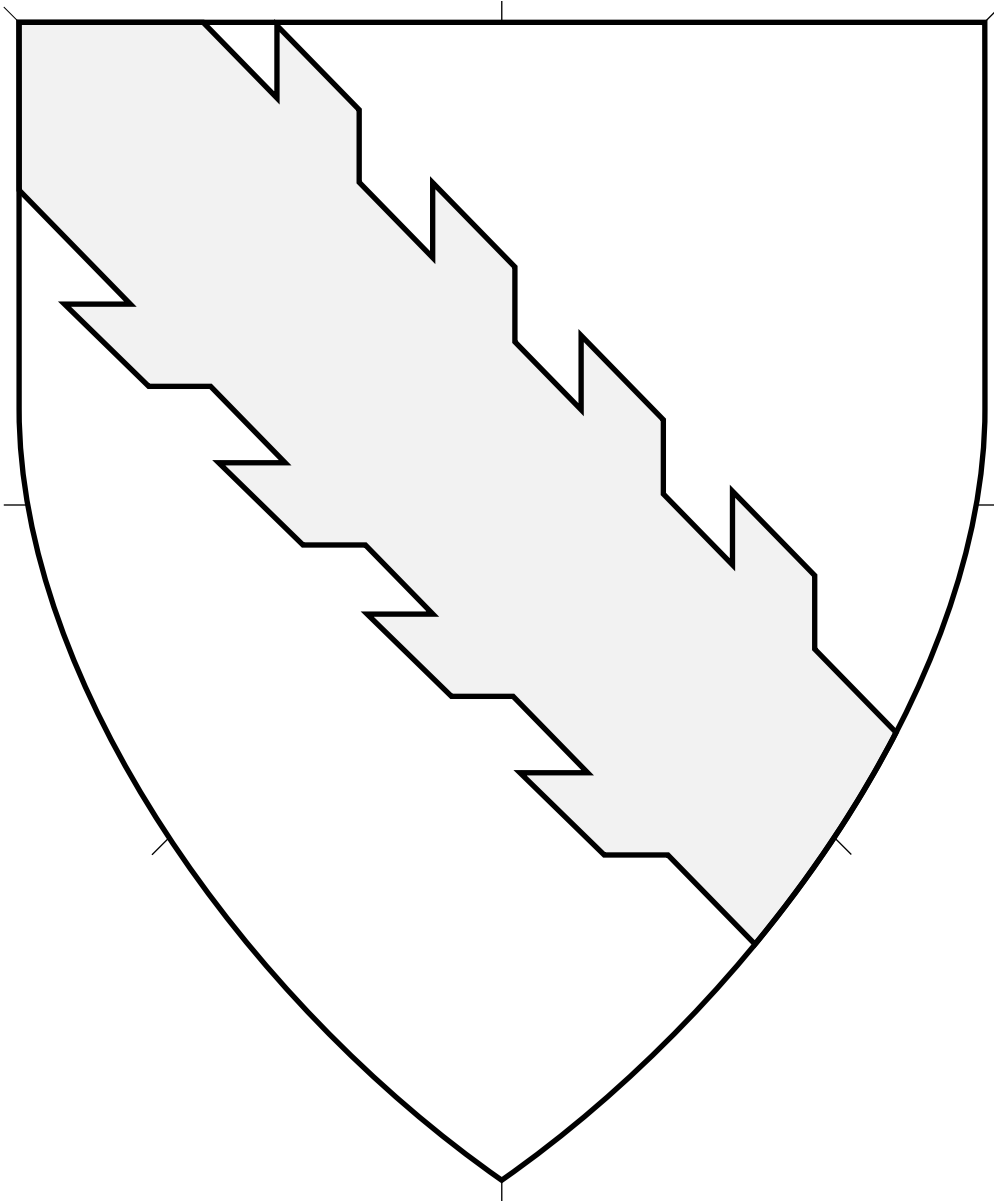

Central ordinary.

Source: Viking Answer Lady SVG Images For Heraldry.
Artist: Gunnvôr silfrahárr. Adapted by Mathghamhain Ua Ruadháin.

Bend Raguly (3) 4.96

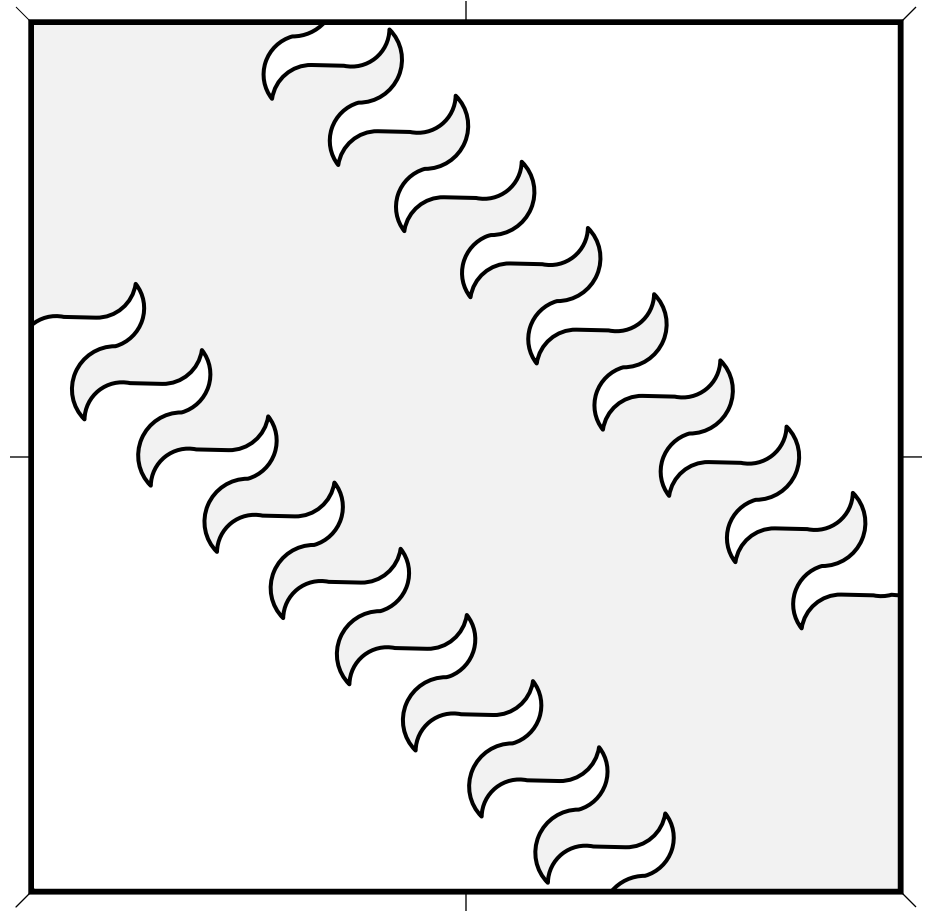
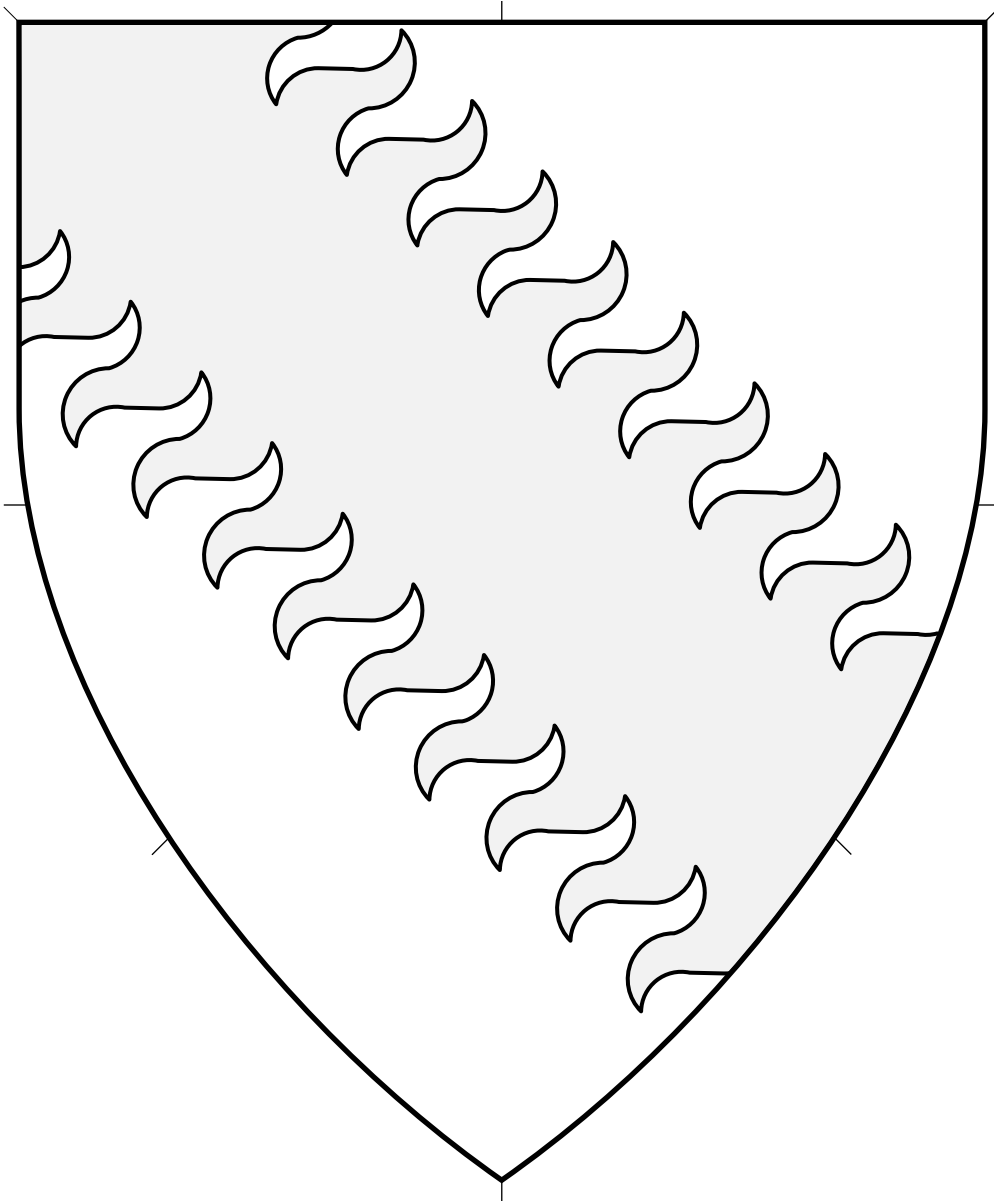

Central ordinary.

Source: Viking Answer Lady SVG Images For Heraldry.
Artist: Gunnvôr silfrahárr. Adapted by Mathghamhain Ua Ruadháin.

Bend Rayonny (1) 4.97

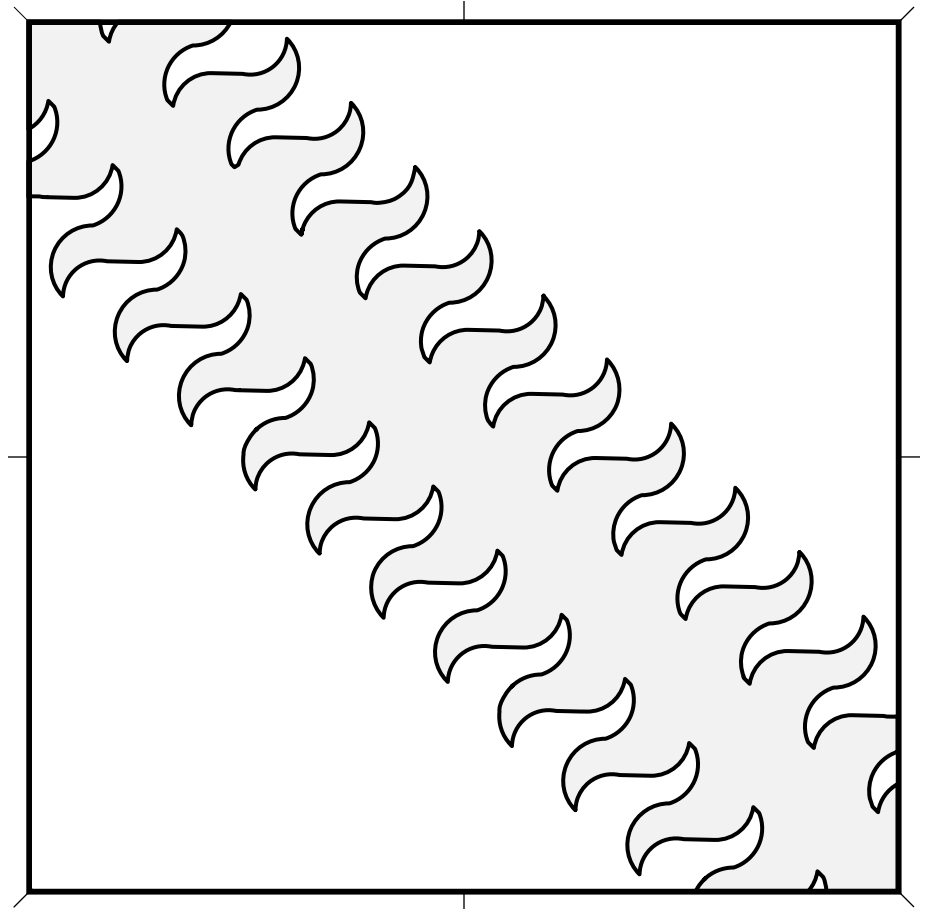
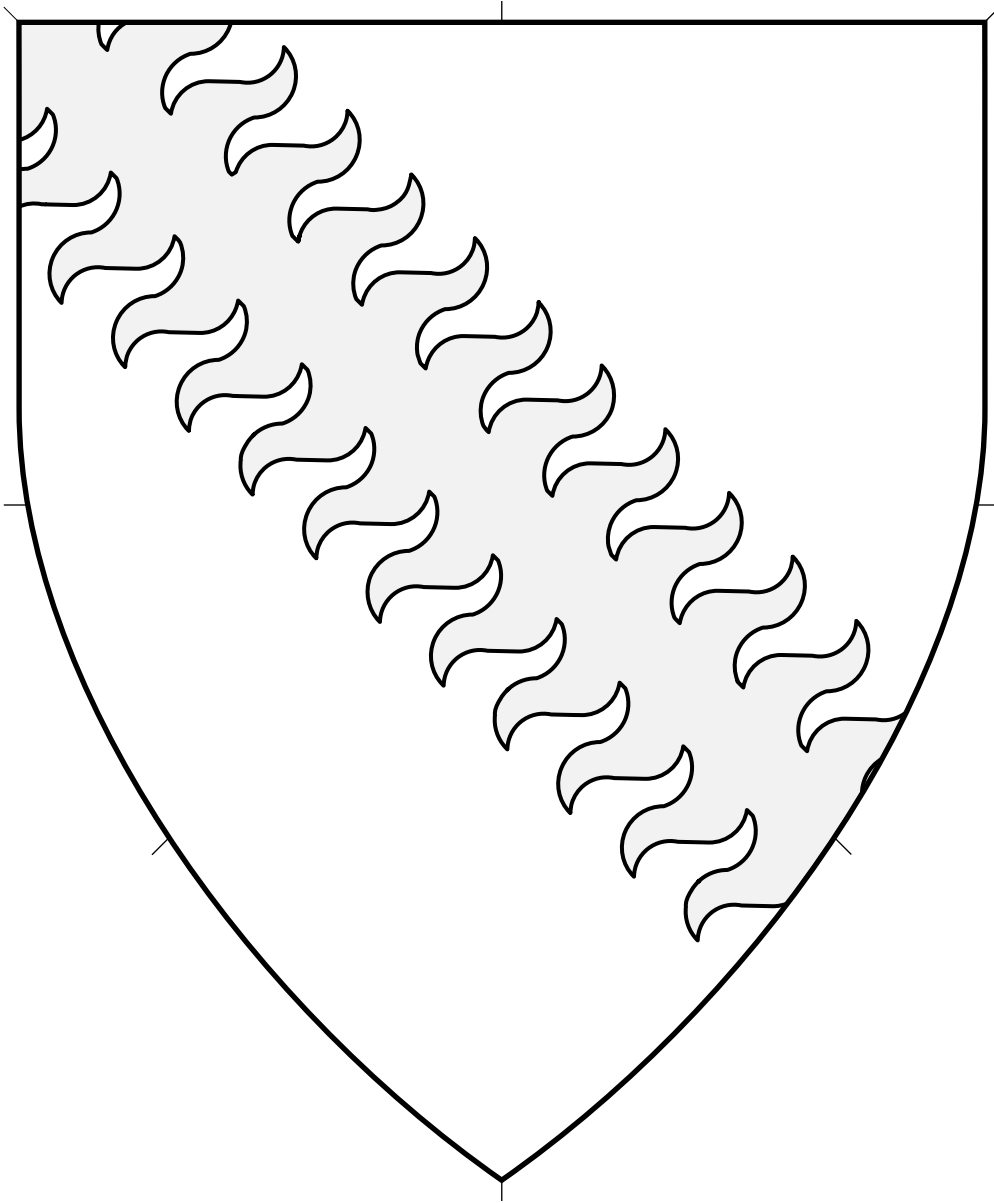

Central ordinary.

Source: Viking Answer Lady SVG Images For Heraldry.
Artist: Gunnvôr silfrahárr. Adapted by Mathghamhain Ua Ruadháin.

Bend Rayonny (2) 4.98

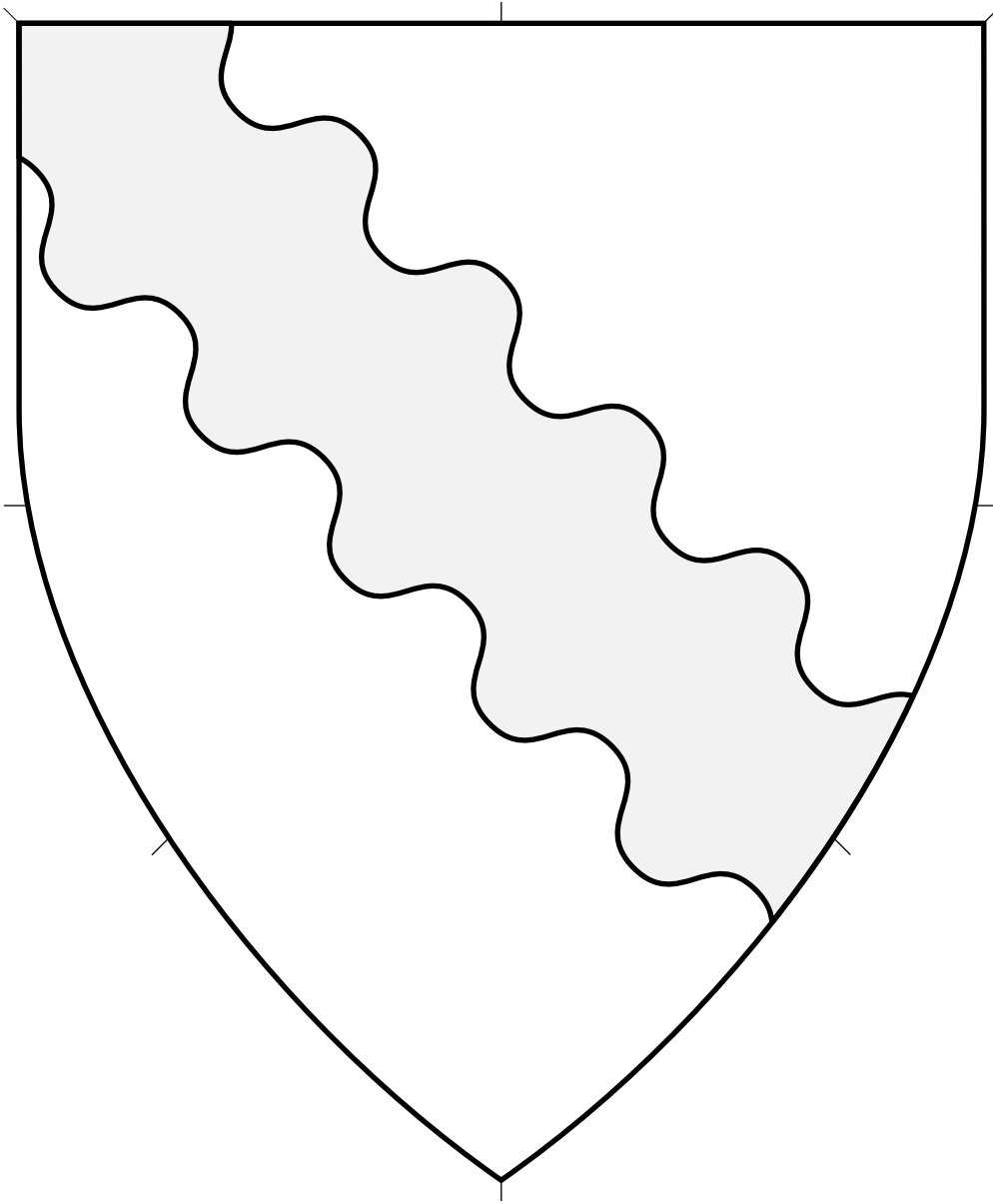

Central ordinary.

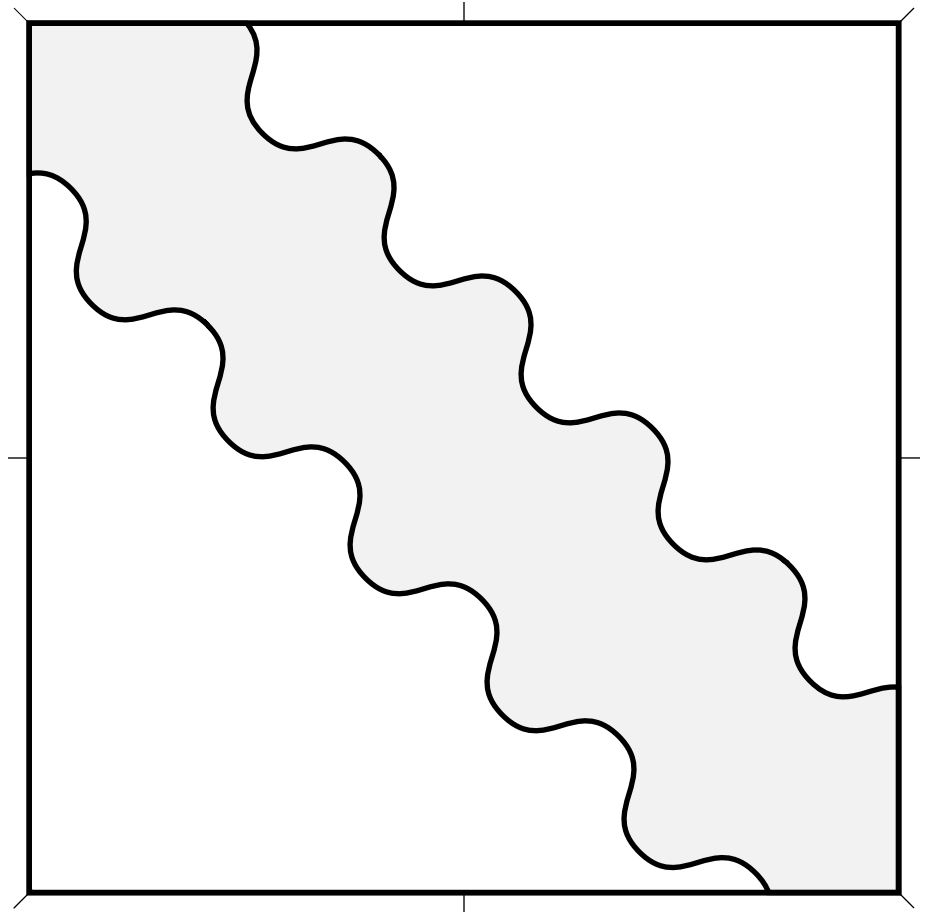

Bend Wavy (1) 4.99

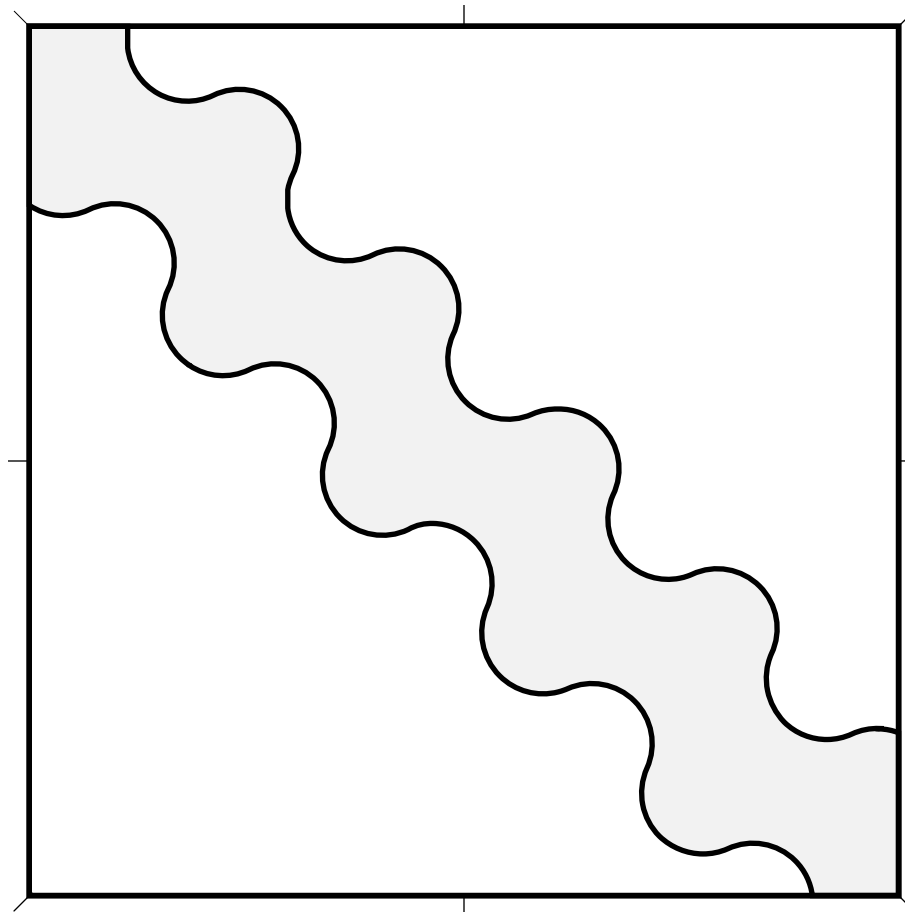
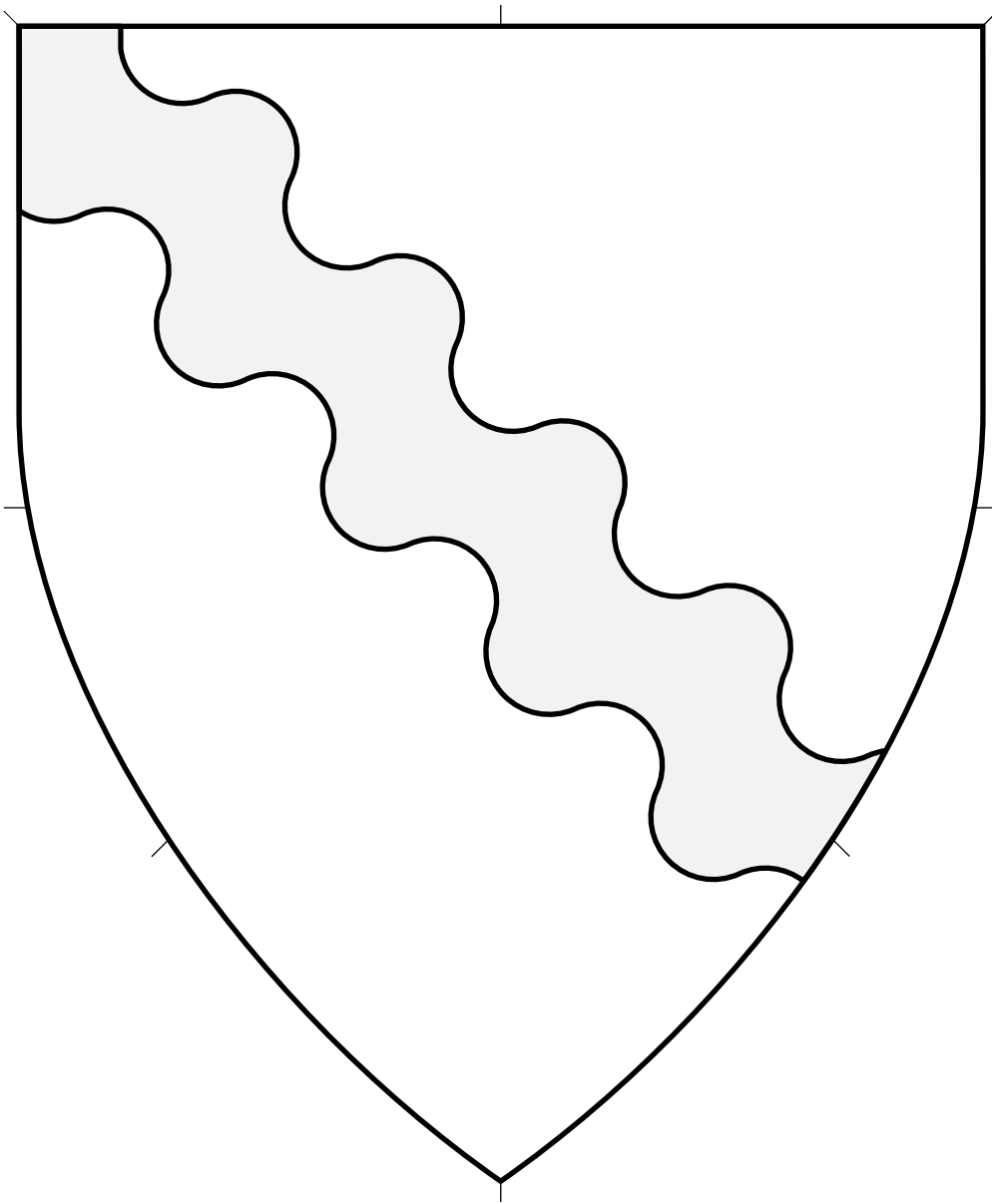

Central ordinary.

Source: Viking Answer Lady SVG Images For Heraldry. Artist: Gunnvôr silfráhr.

Bend Wavy (2) 4.100

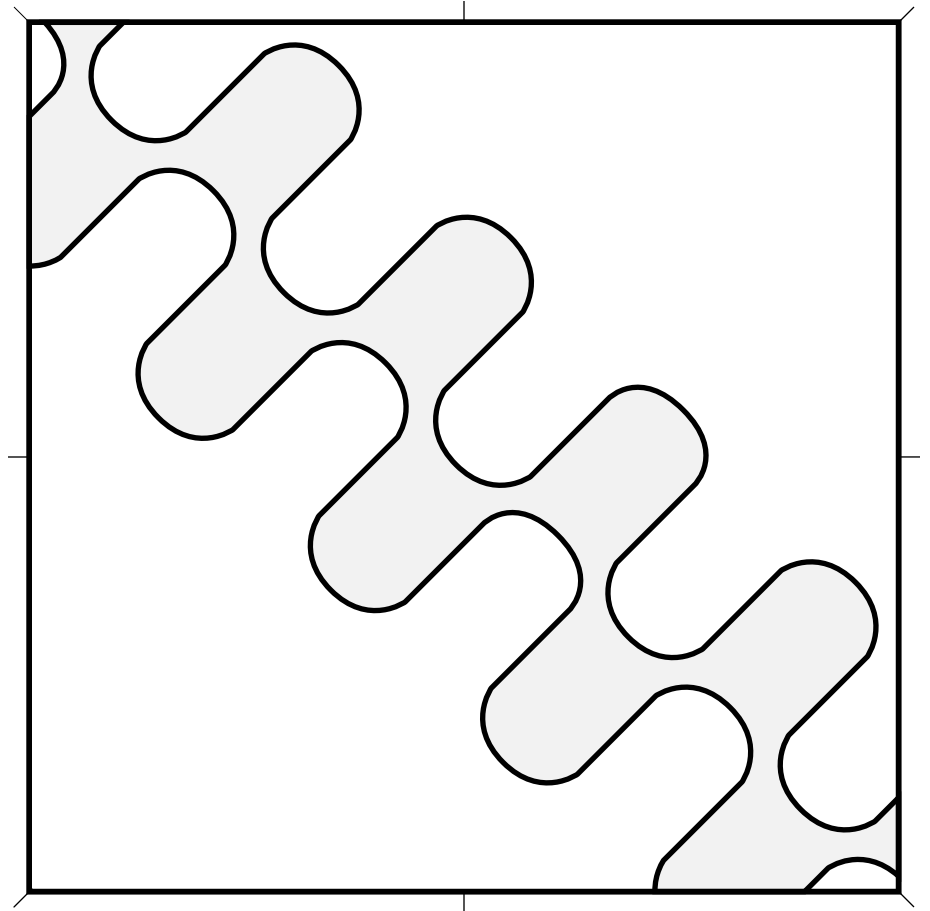
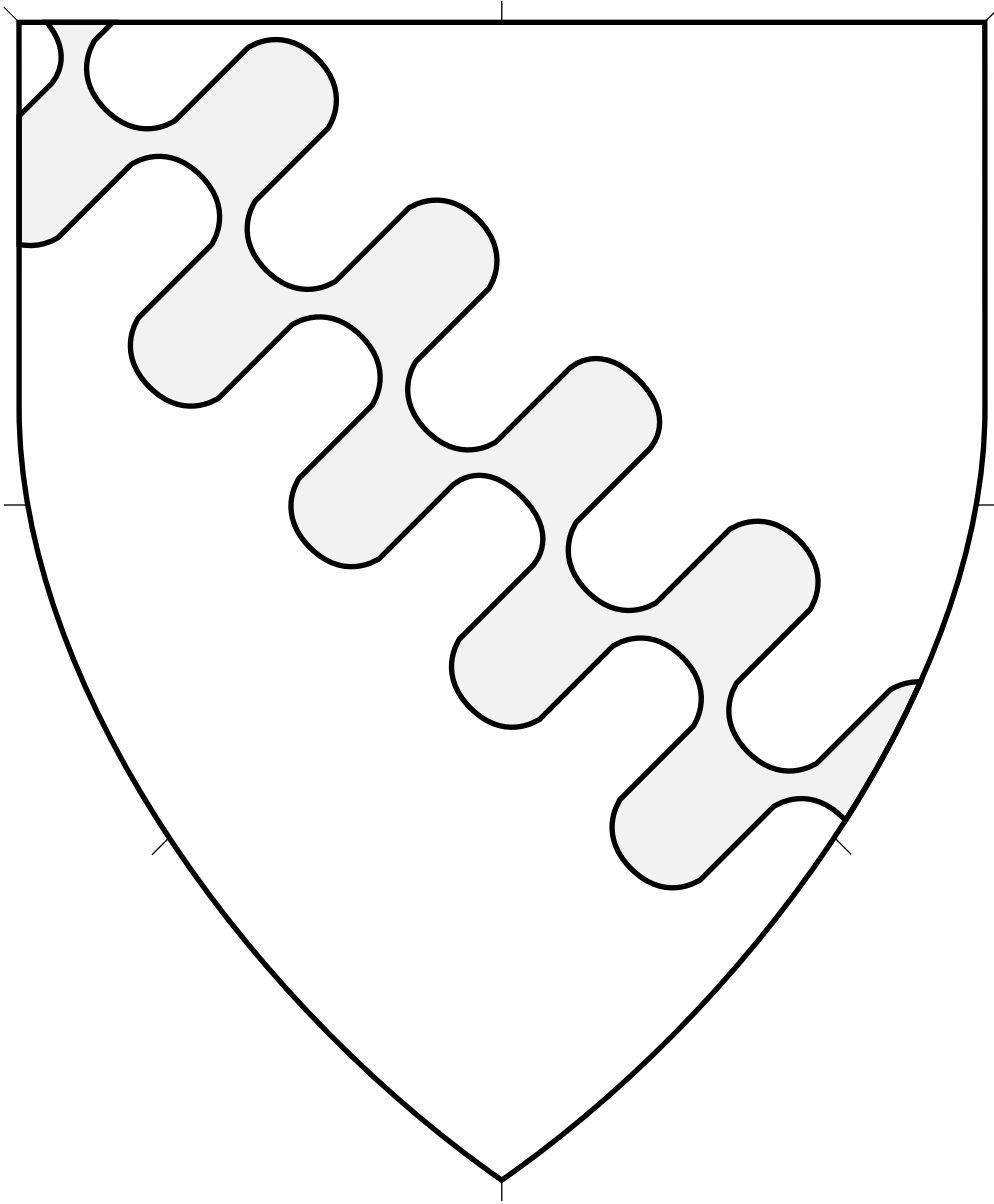

Central ordinary.

Source: Fenwick Roll. Artist unknown.
Adapted by Mathghamhain Ua Ruadháin.

Bend Wavy (3) 4.101

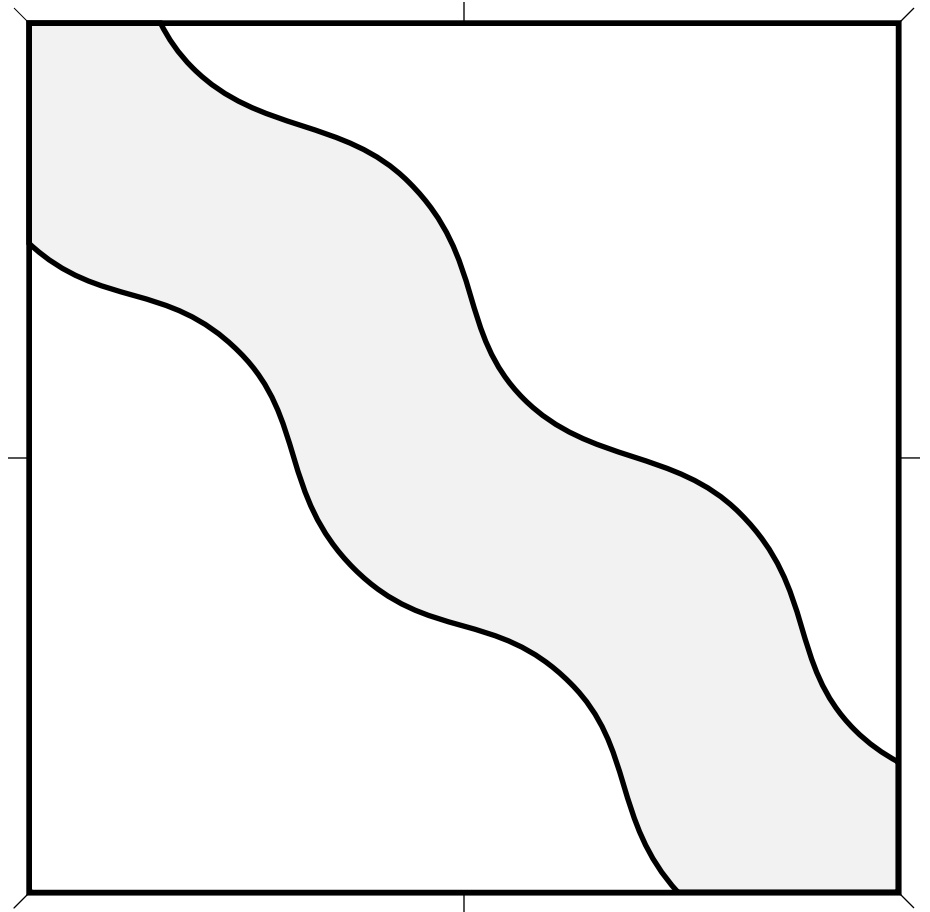
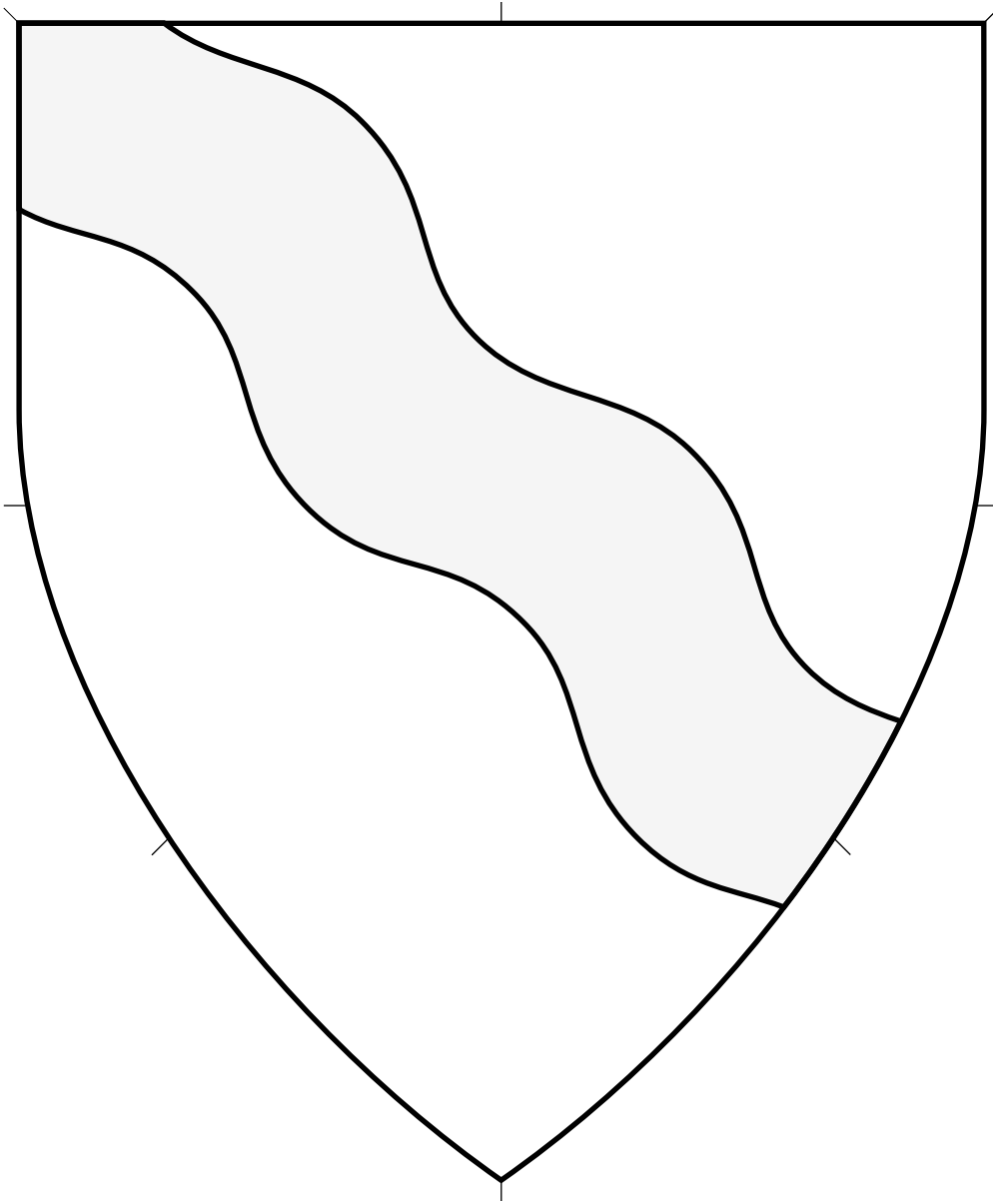

Central ordinary.

Source: Scheibler Armorial. Artist: Unknown. (Page 151.)

Bend Wavy (4) • 4.102

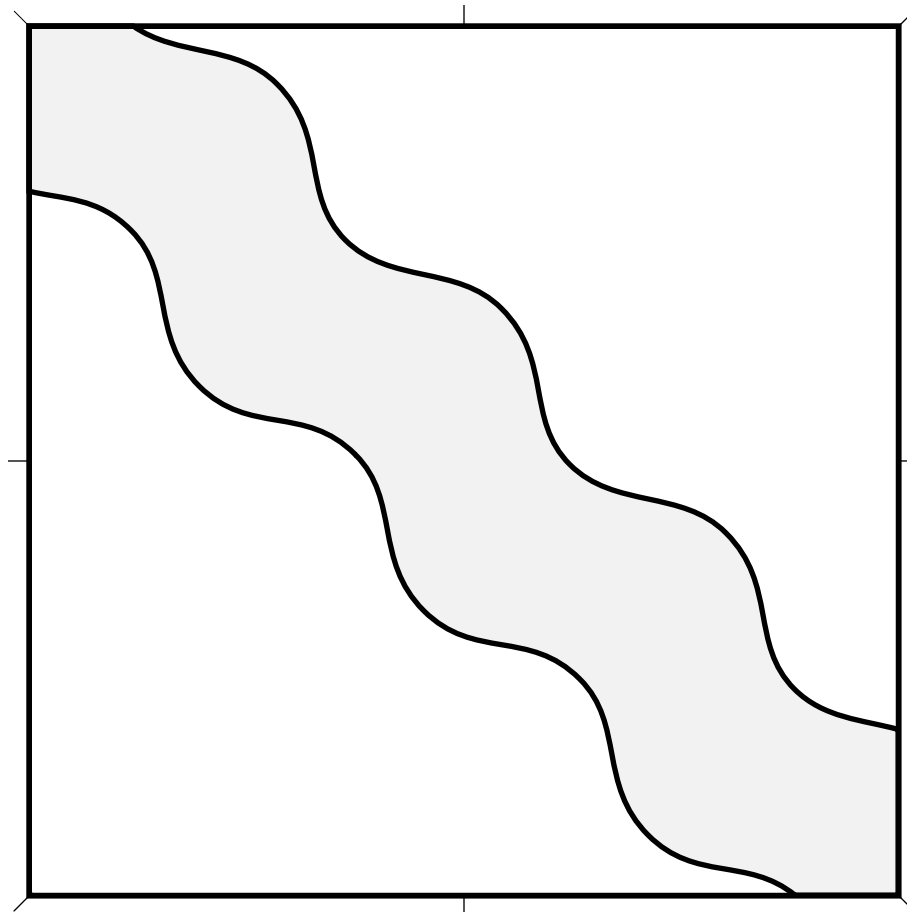
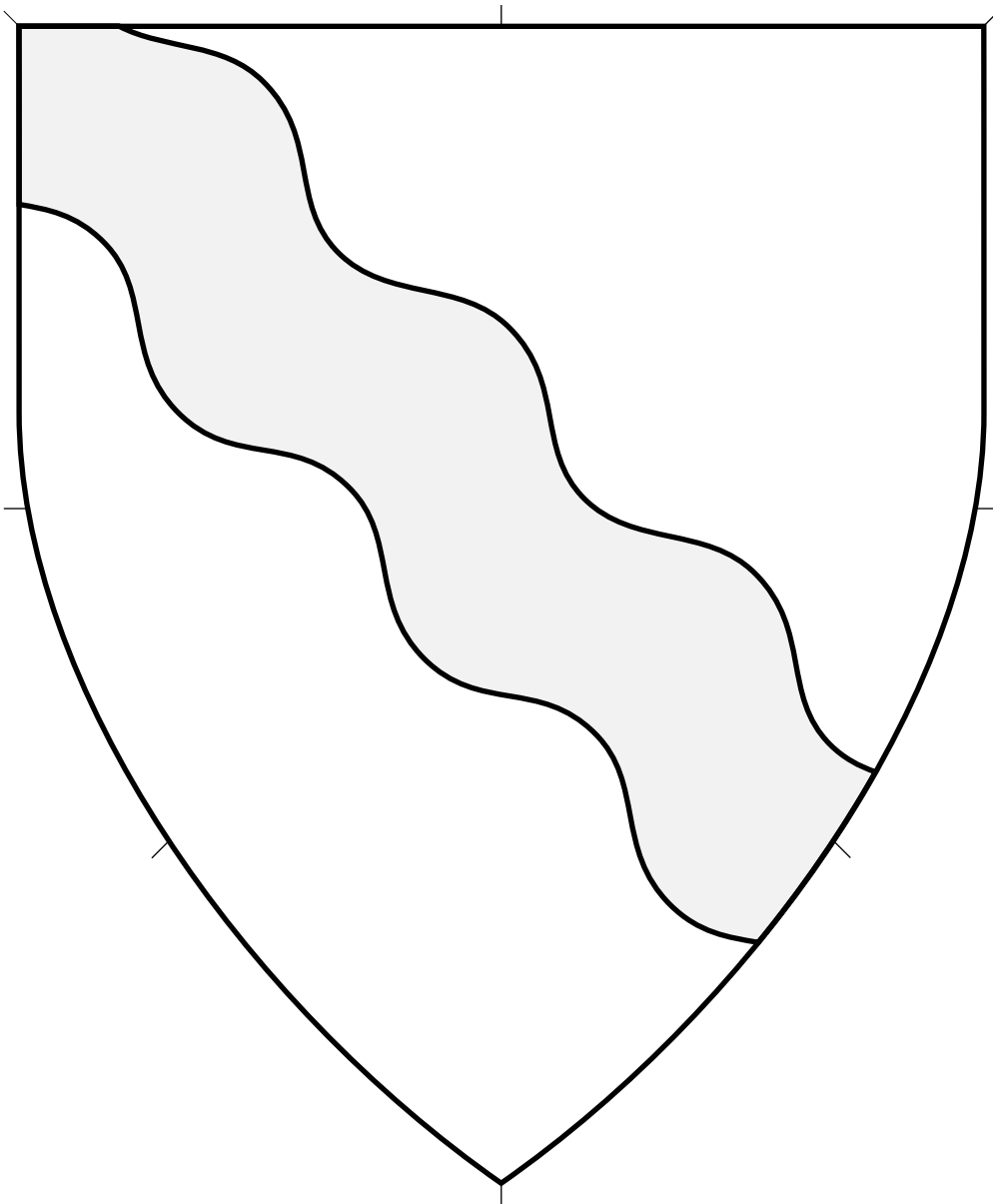

Central ordinary.

Source: Sammelband Mehrerer Wappenbücher. Artist unknown. (Folio 18v.)

Bend Wavy (5) 4.103

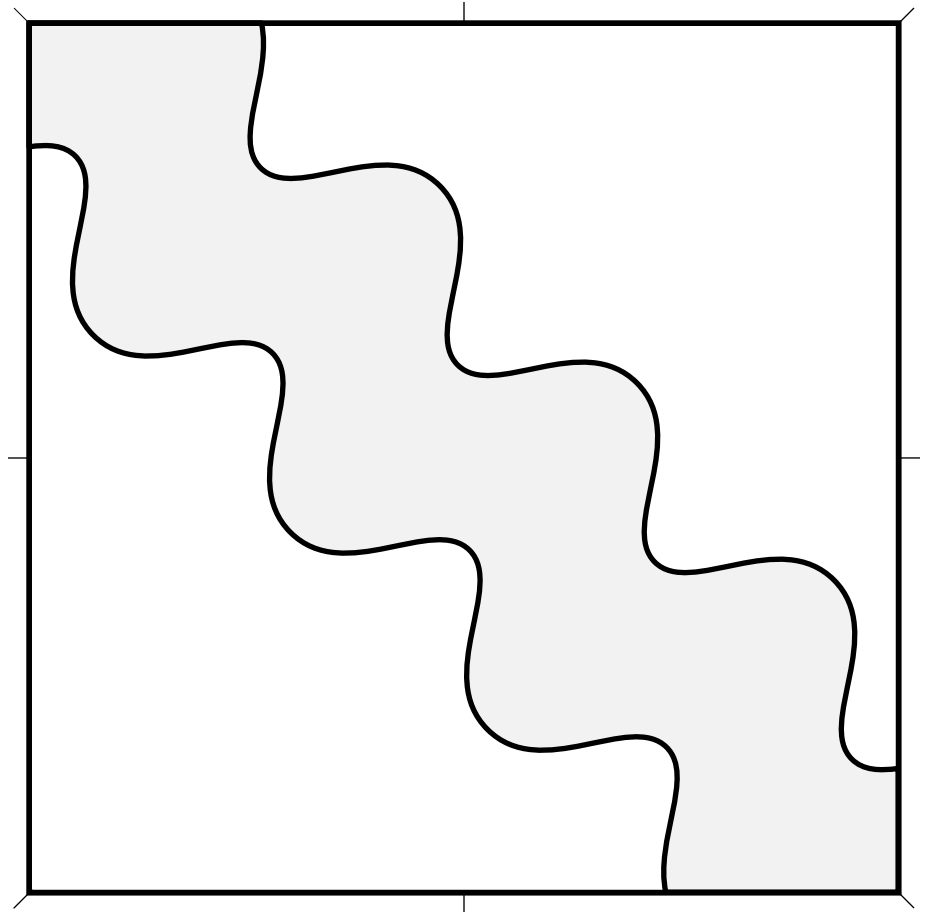
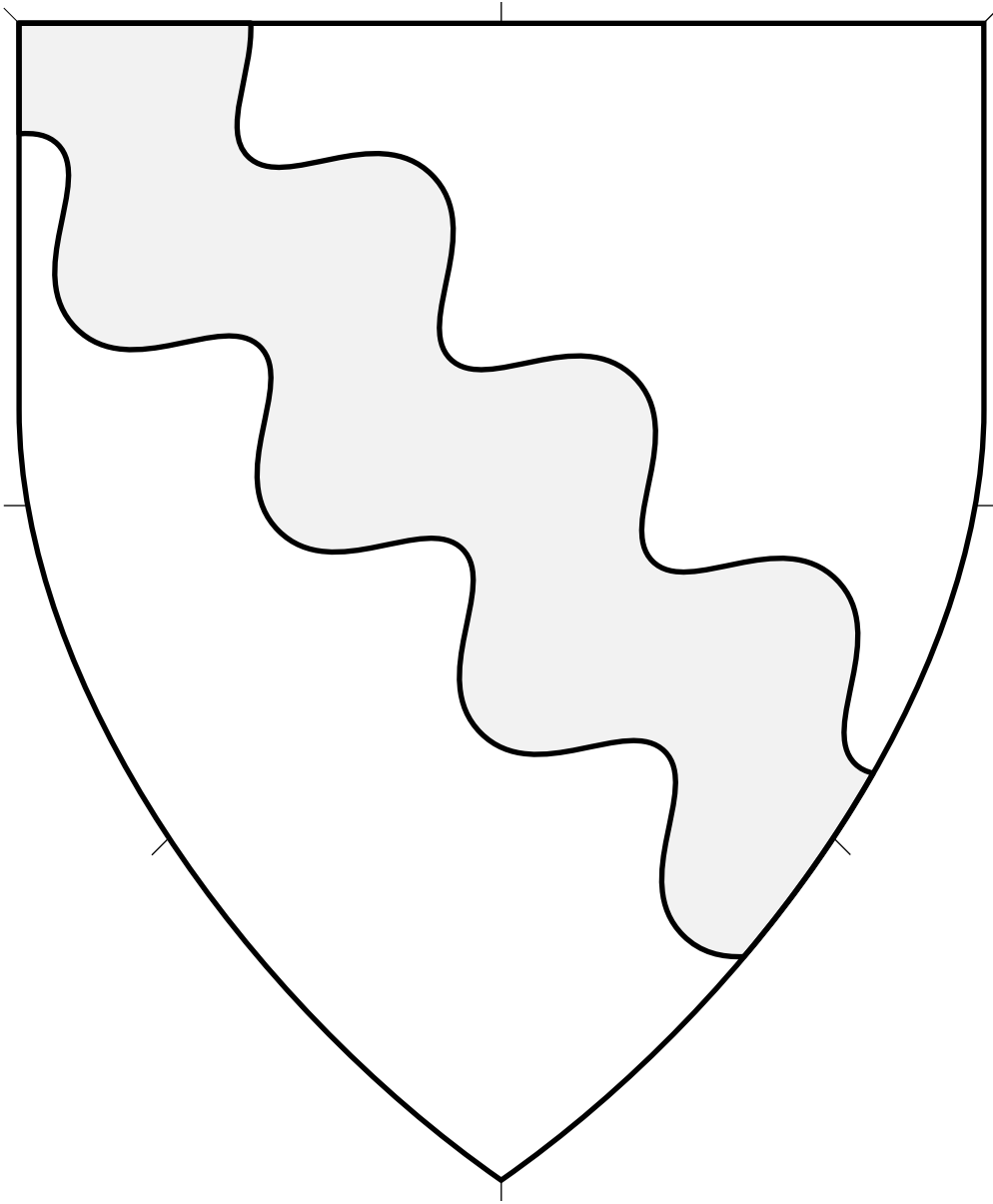

Central ordinary.

Source: St. Gallen Armorial. Artist unknown. (Page 111.)

Bend Wavy (6) • 4.104

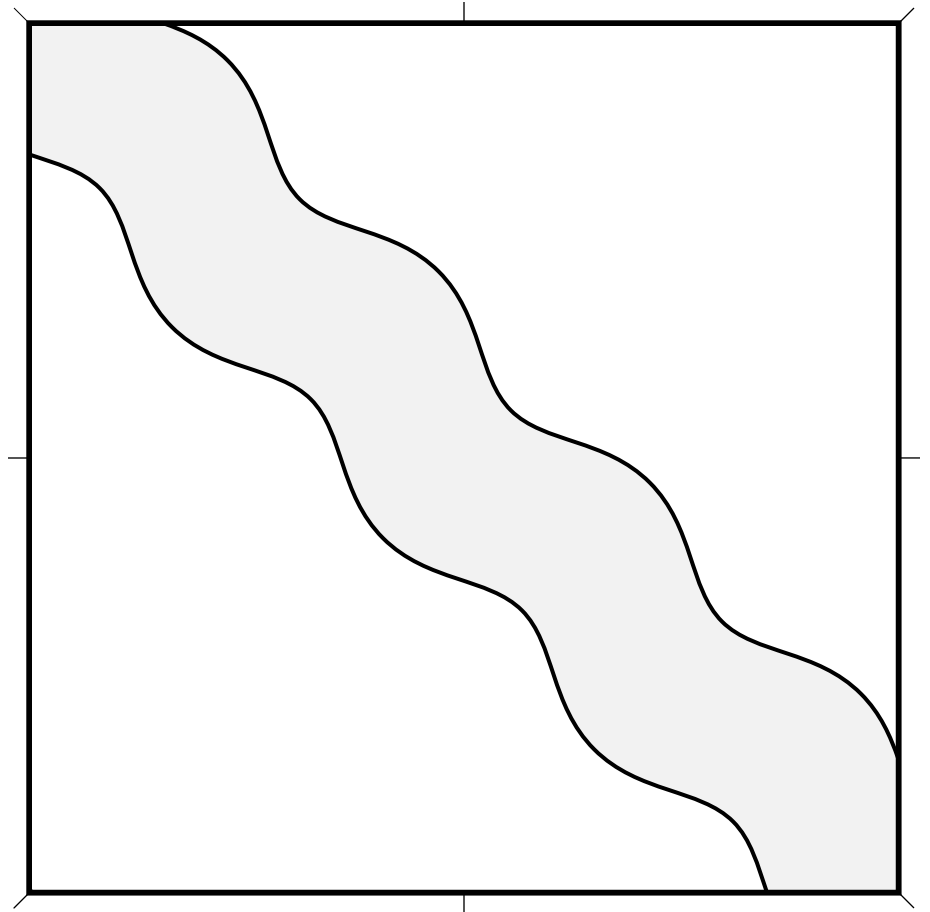
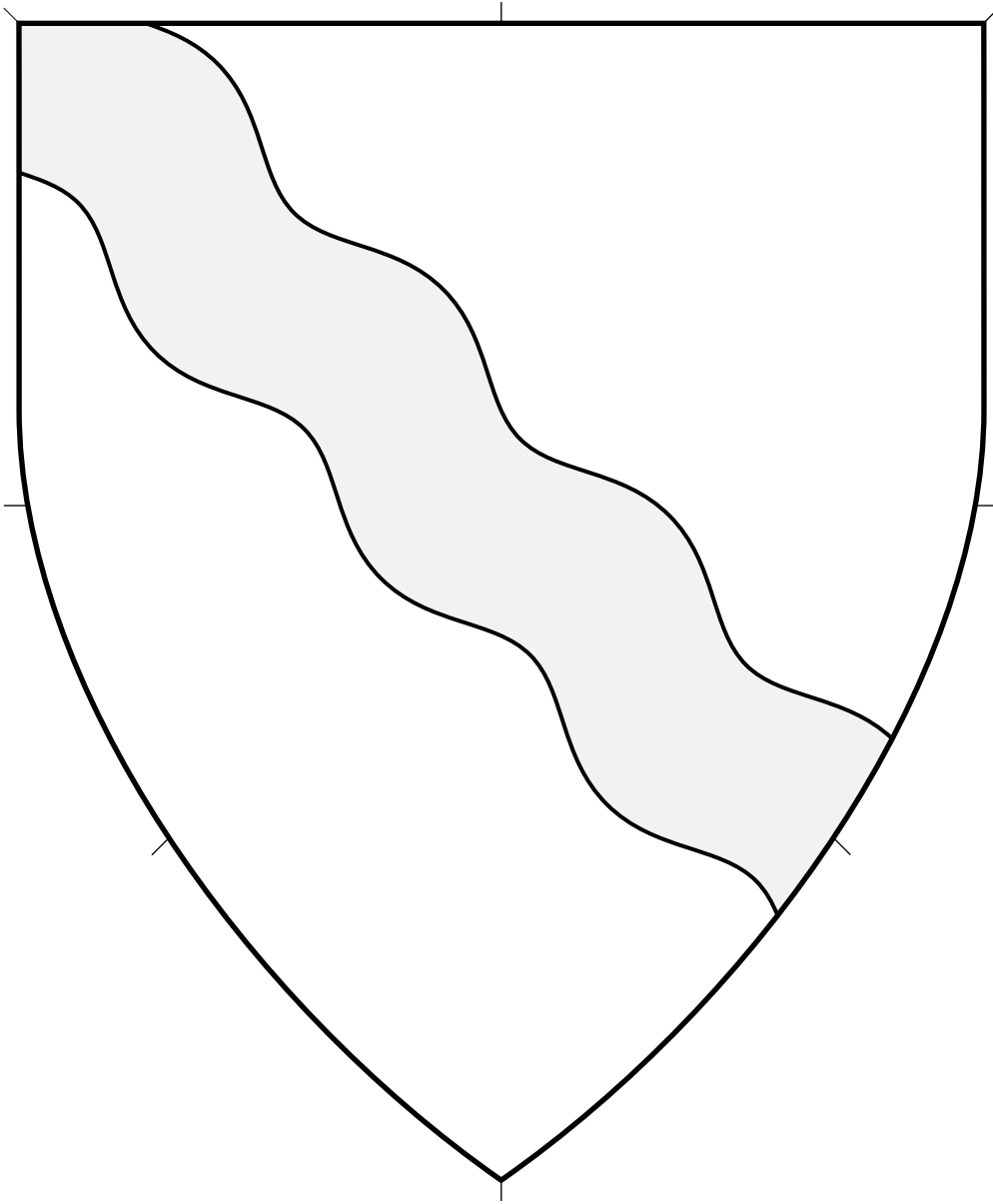

Central ordinary.

Bend Wavy (7) 4.105

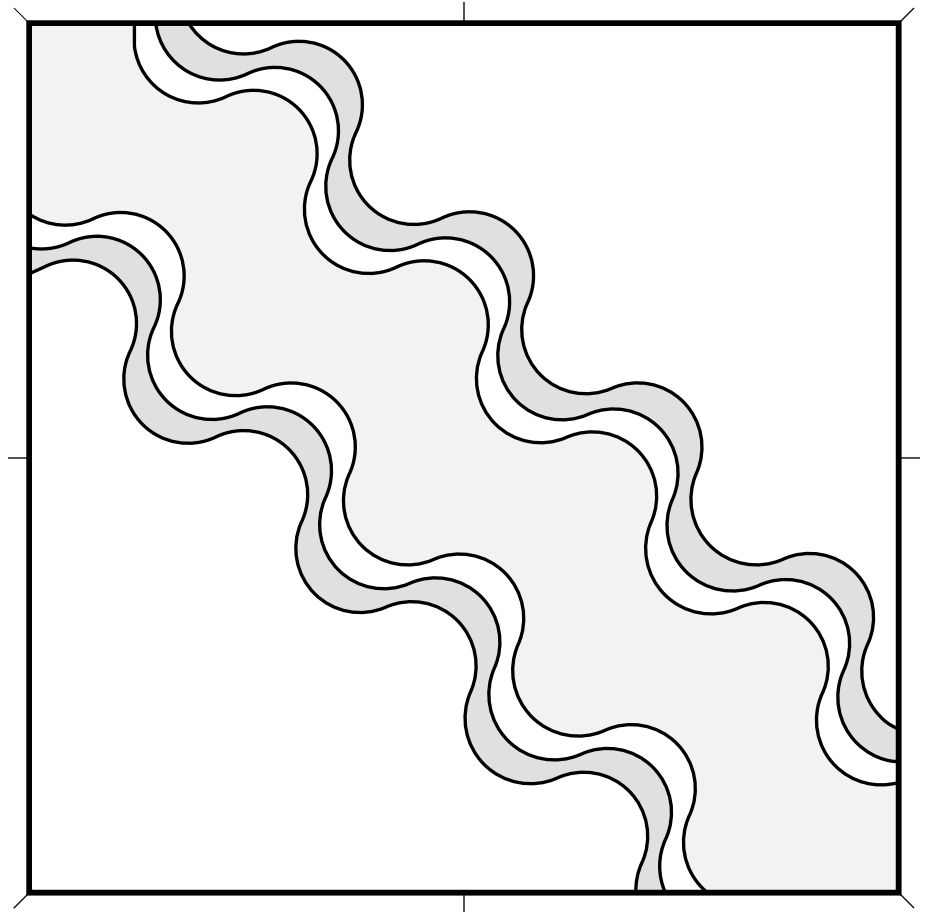
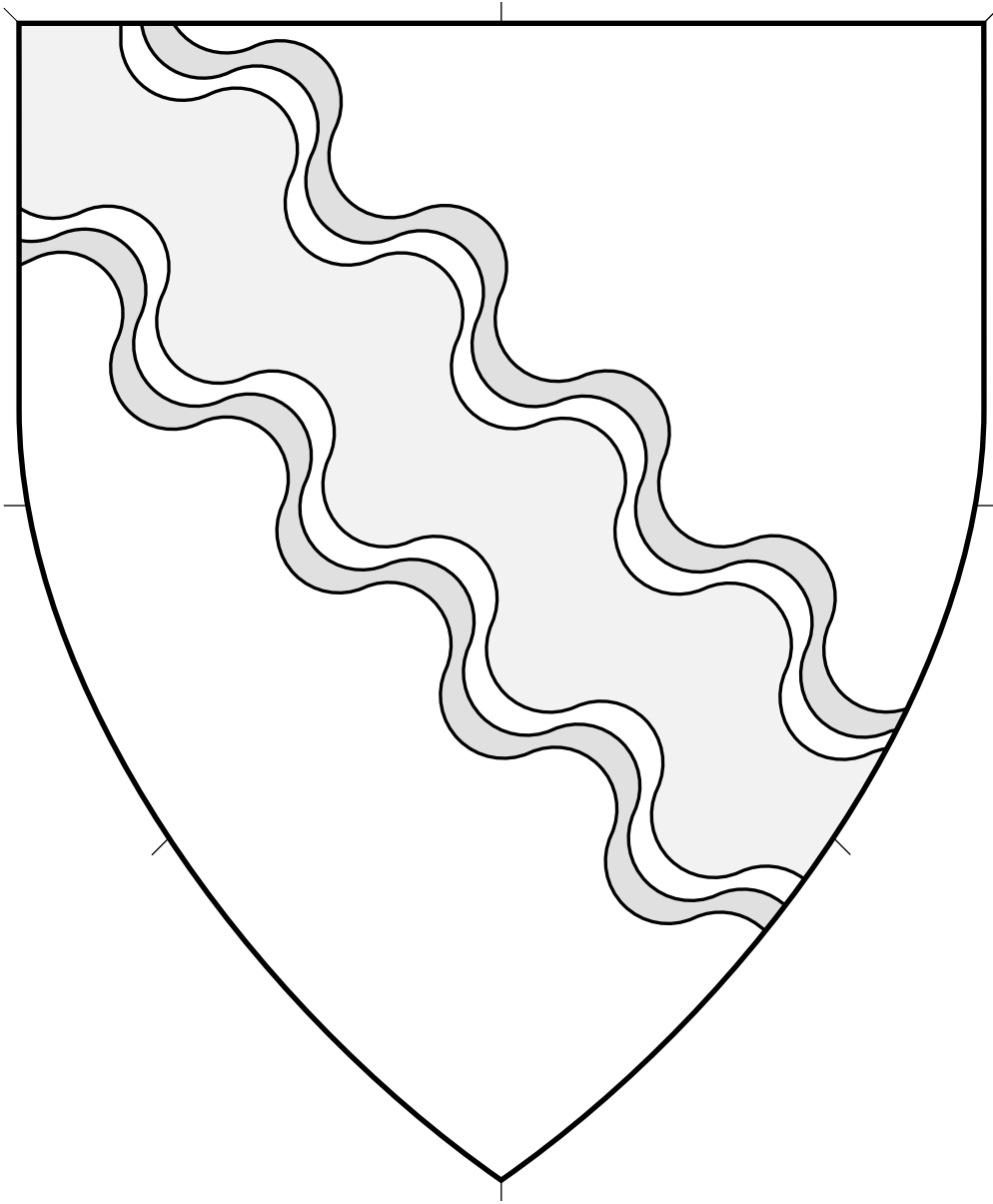

Central ordinary.
Artist: Vémundr Syvursson.

Bend Wavy Cotised 4.106

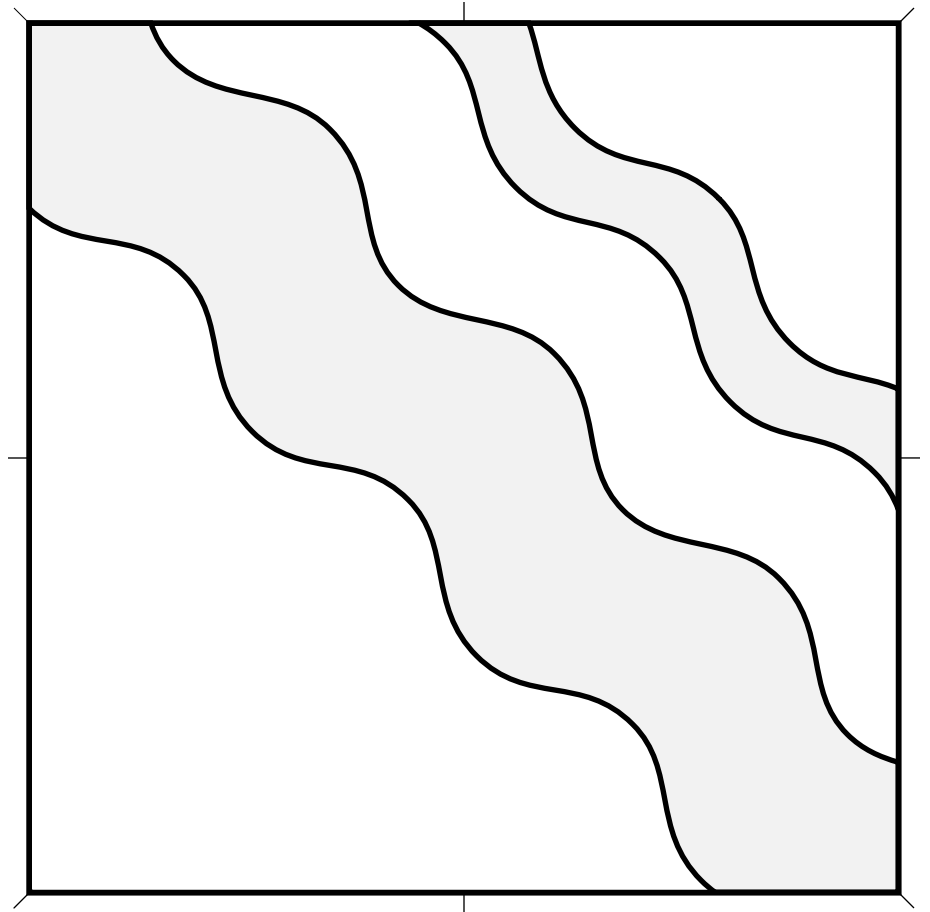
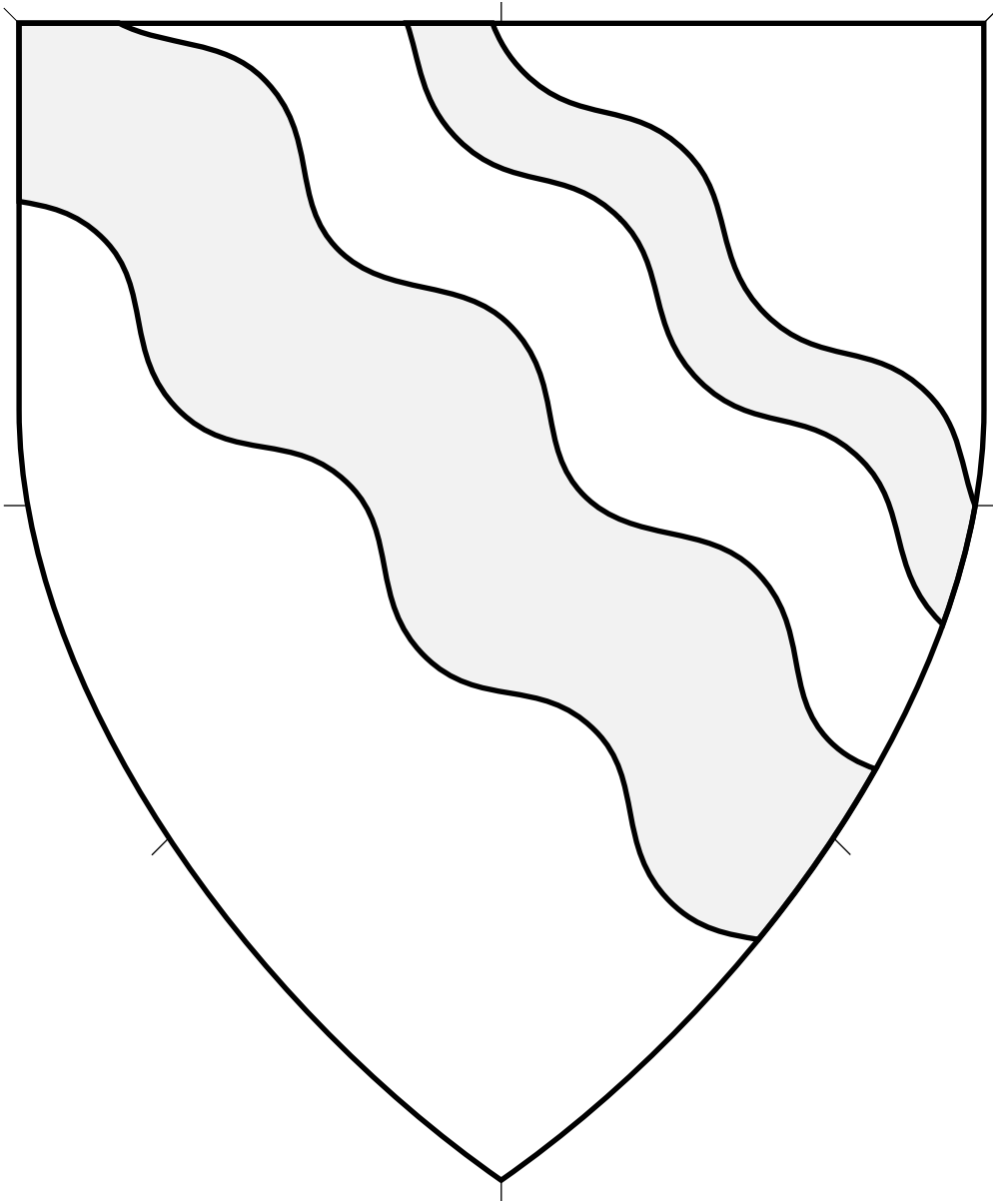

Central ordinary.

Source: Sammelband Mehrerer Wappenbücher.
Artist unknown. (Folio 18v.)

Bend Wavy Singly Cotised 4.107

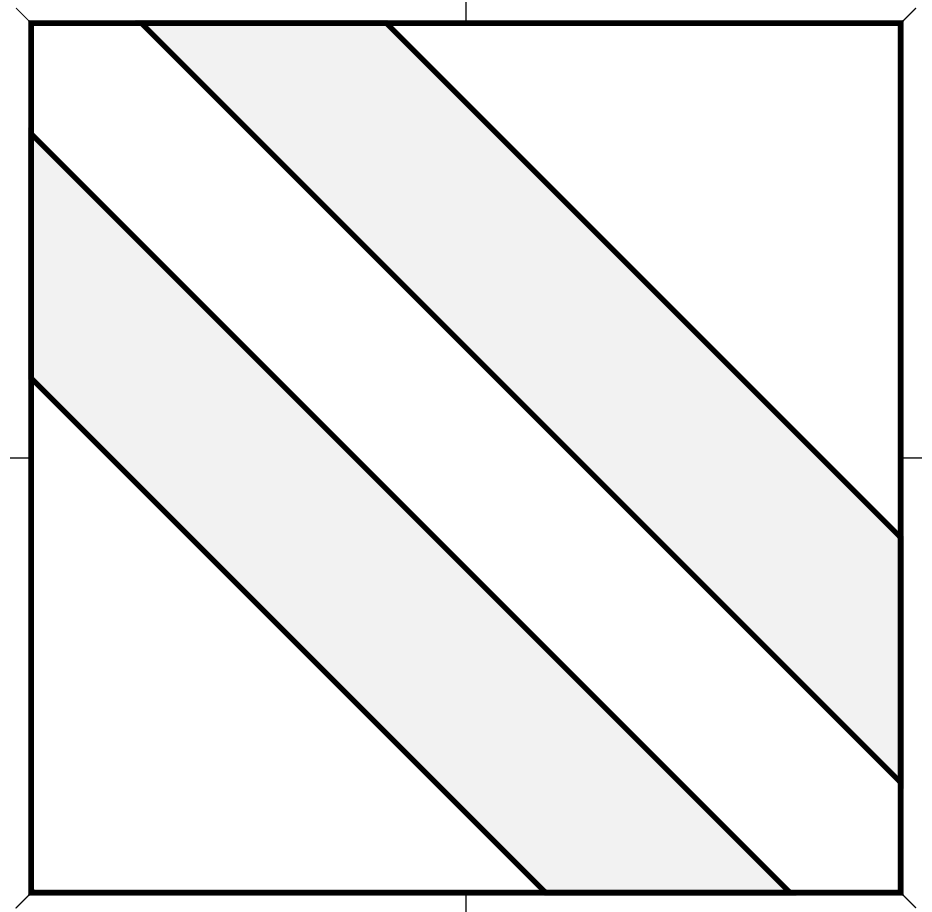
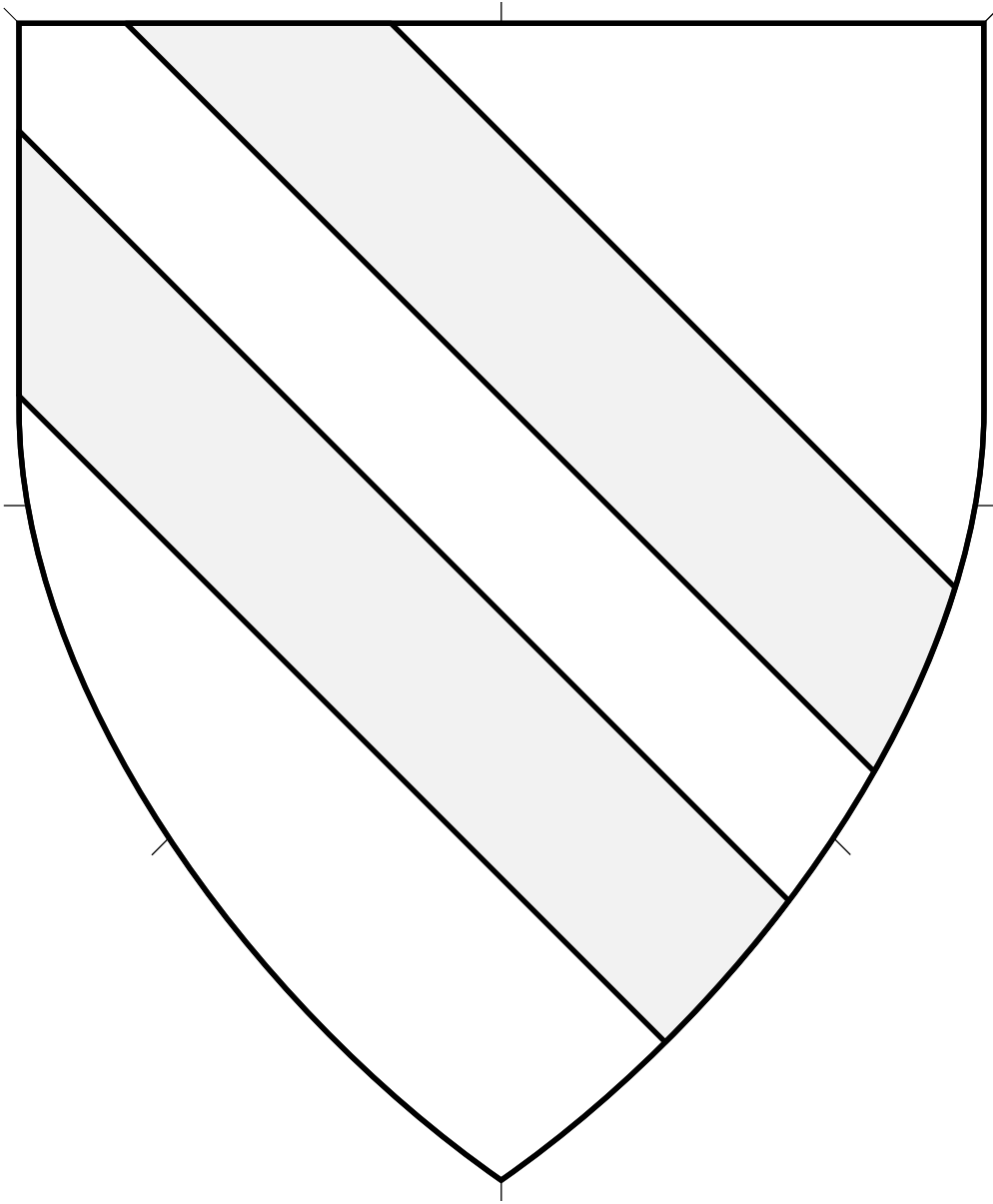

Central ordinary. Diminutive of the bend.

Bendlets, 2 (1) 4.108

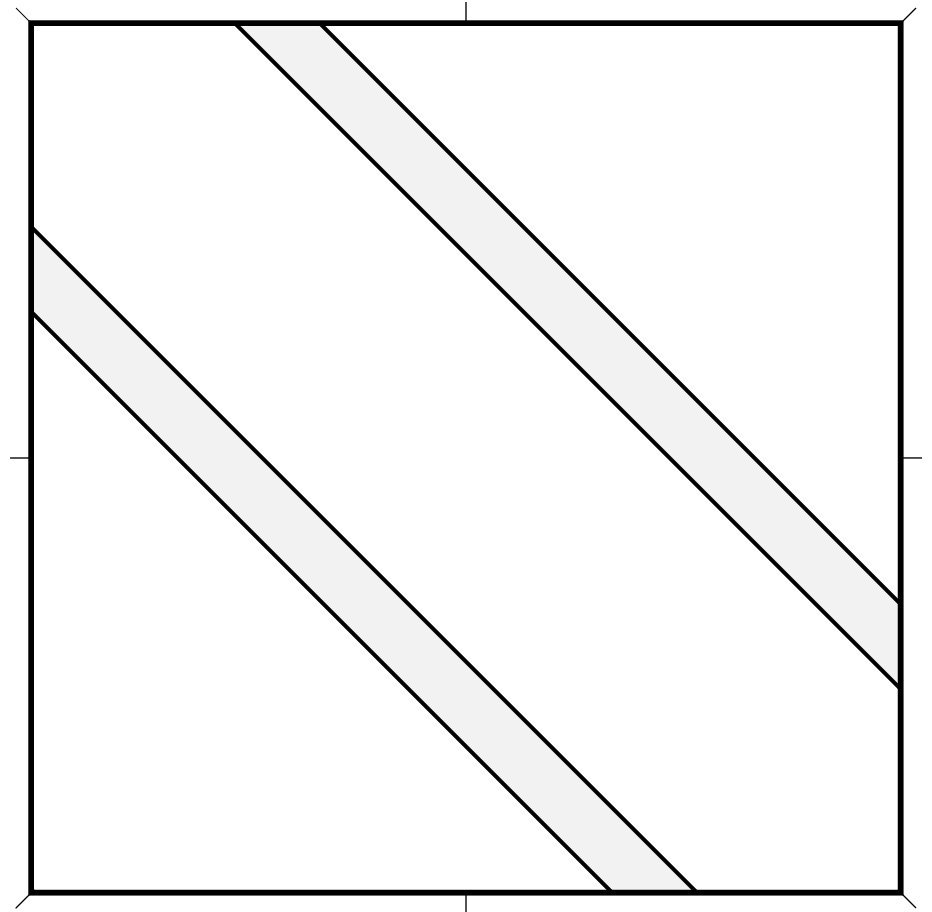
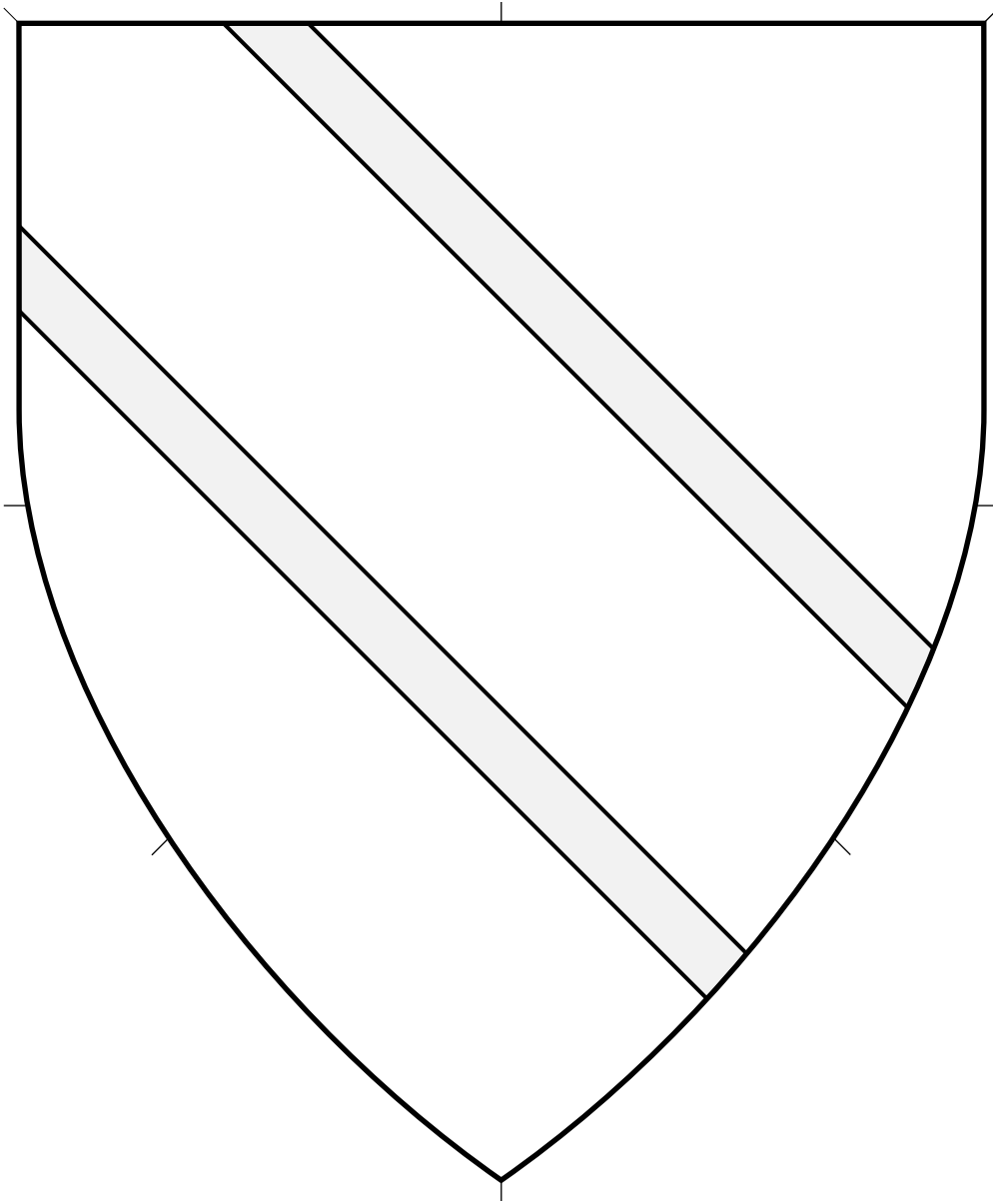

Central ordinary. Diminutive of the bend.

Source: Insignia Urbium Italiae Septentrionalis.
Artist unknown. (Folio 237, arms of De Medalia.)

Bendlets, 2 (2) • 4.109

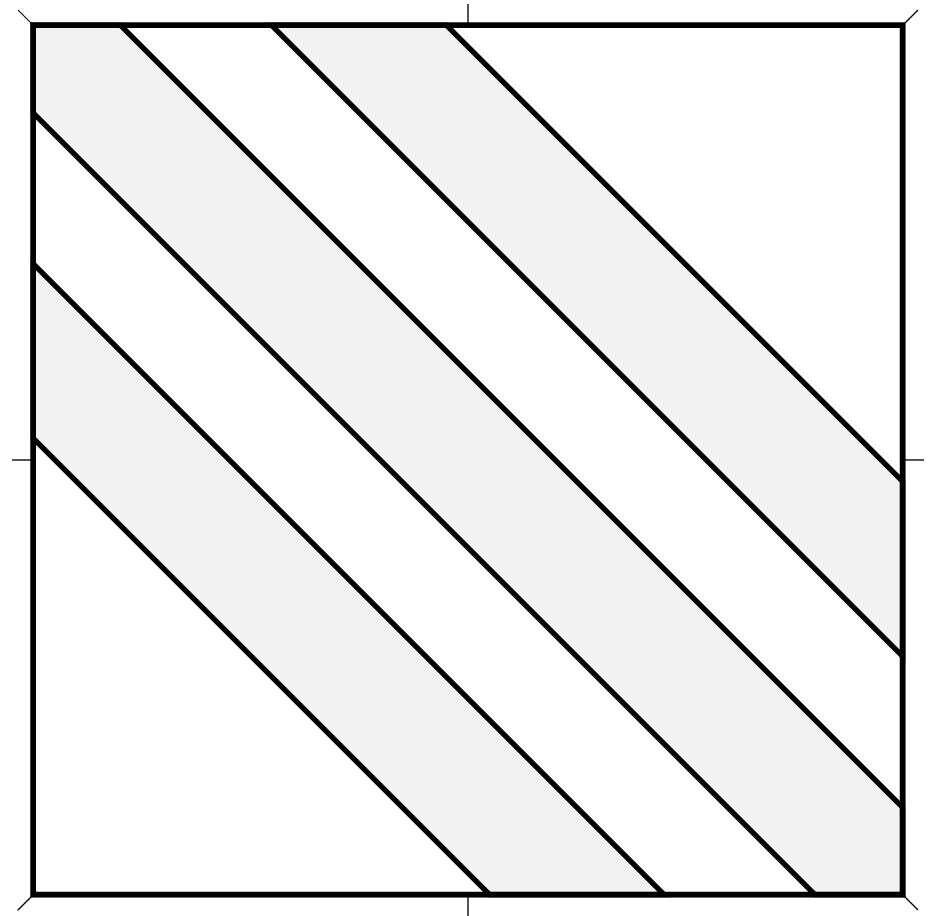
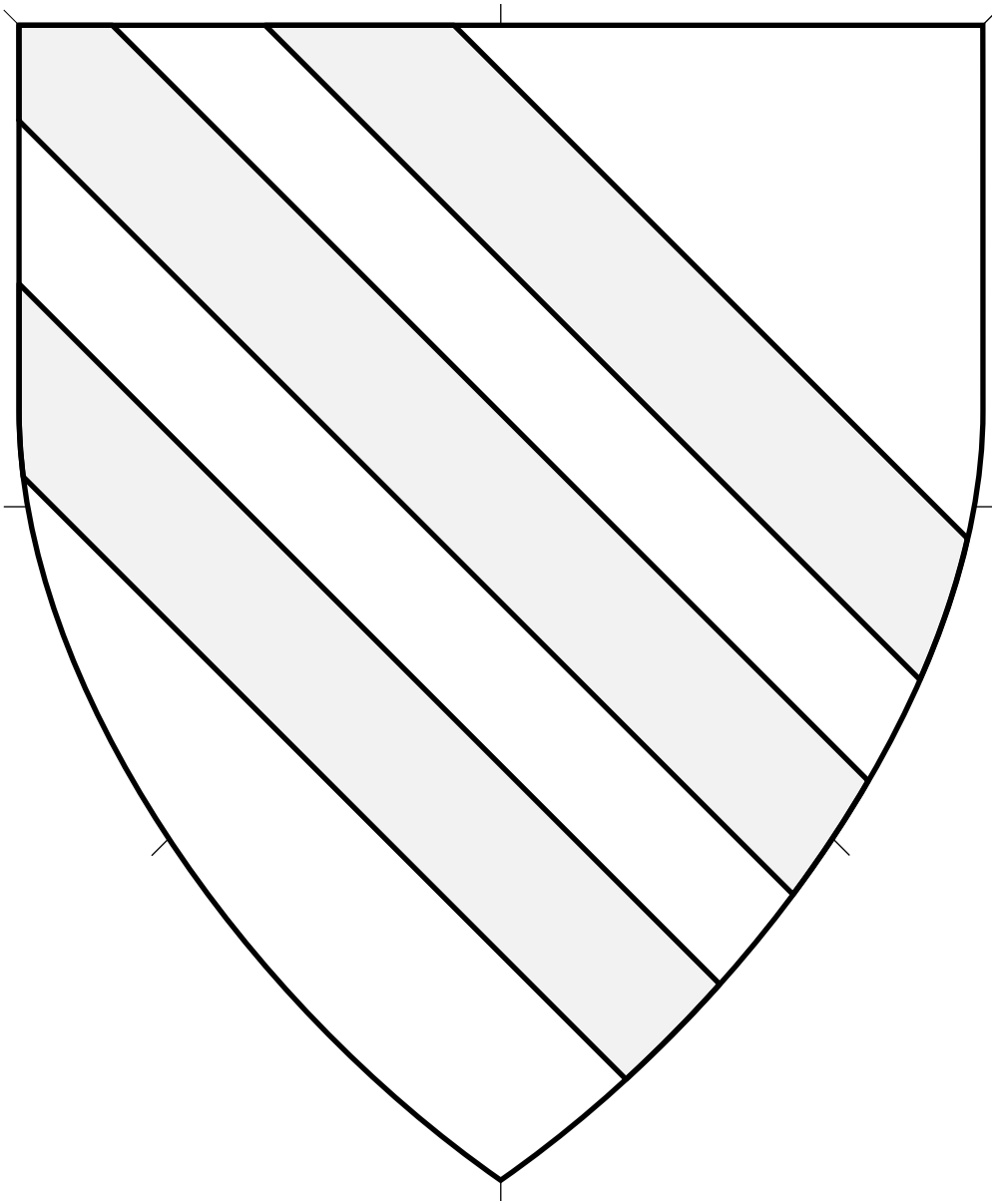

Central ordinary. Diminutive of the bend.

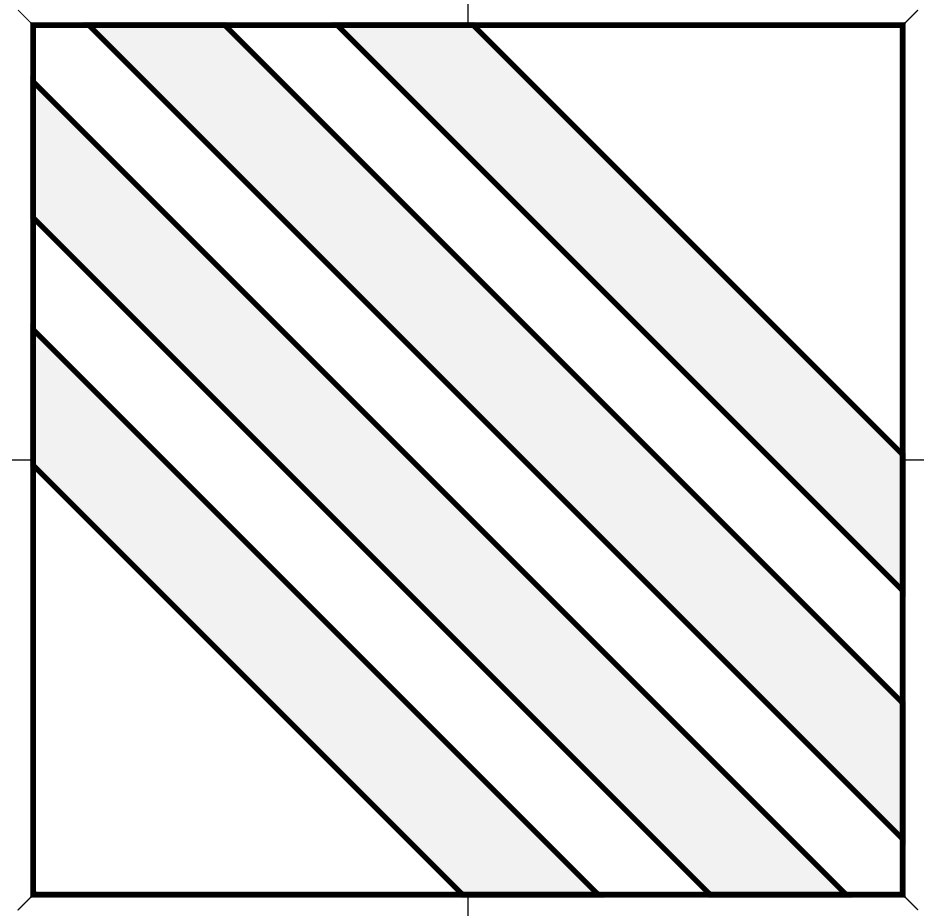
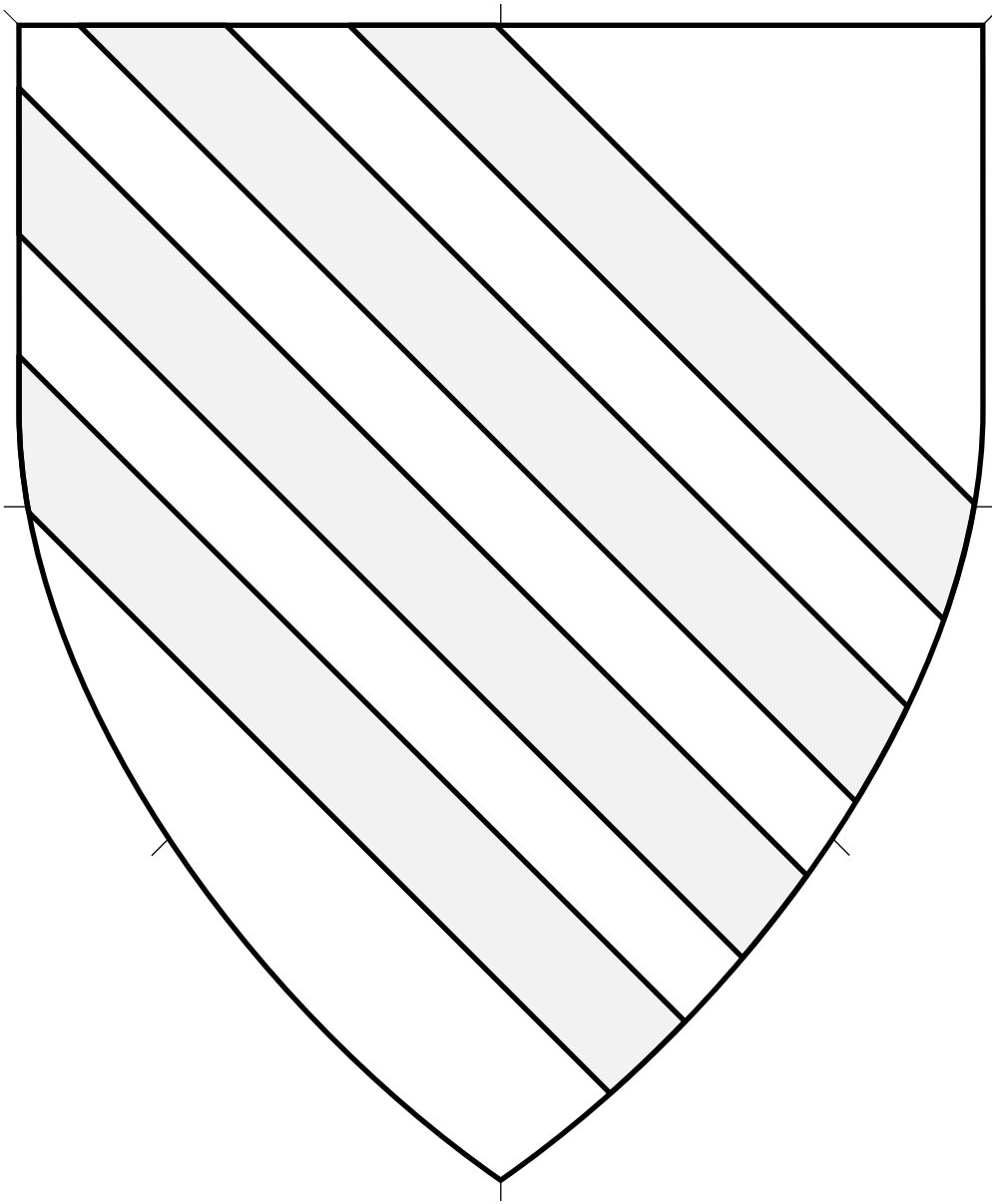

Central ordinary. Diminutive of the bend.

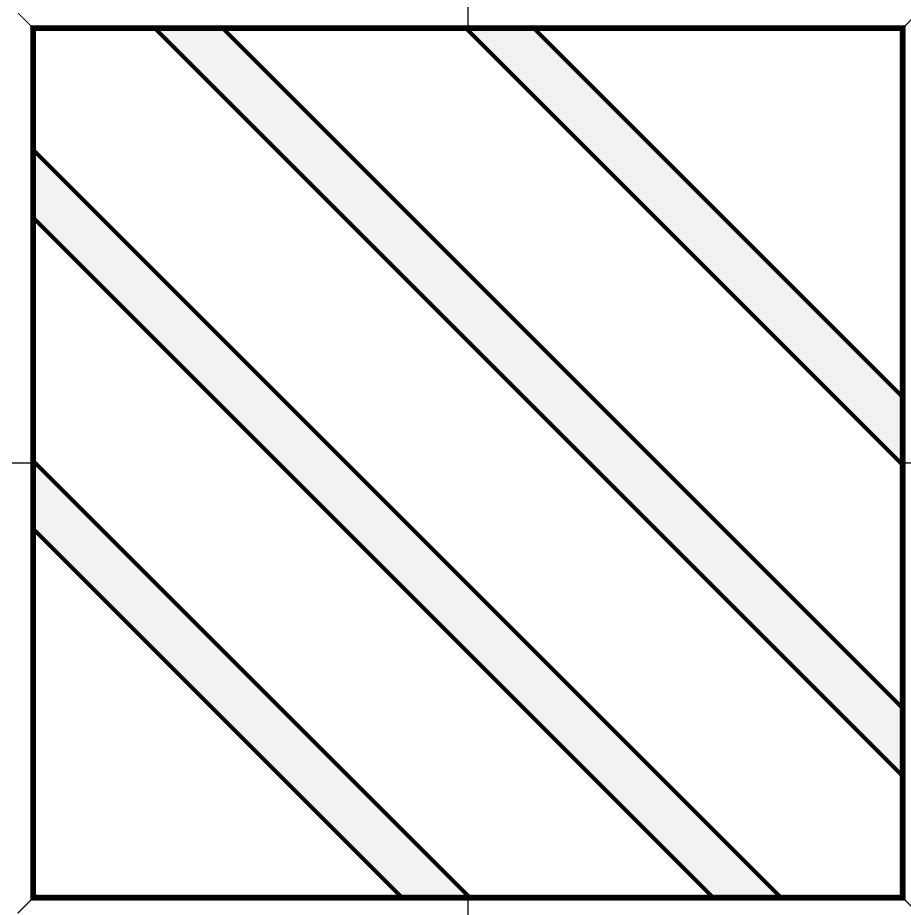
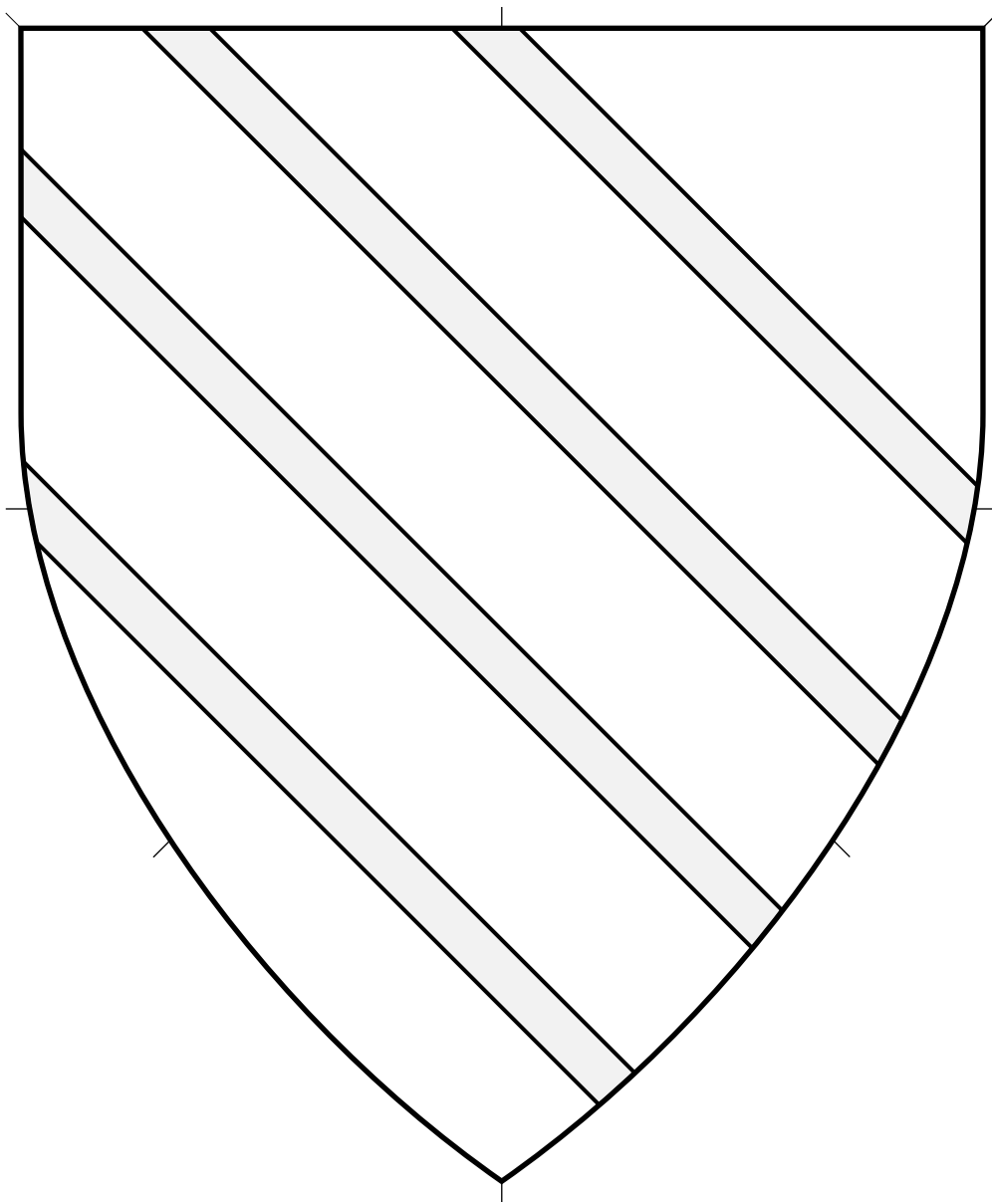

Central ordinary. Diminutive of the bend.

Source: Insignia Urbium Italiae Septentrionalis.
Artist unknown. (Folio 127r, arms of De Caretis.)

Bendlets, 4 (2) 4.112

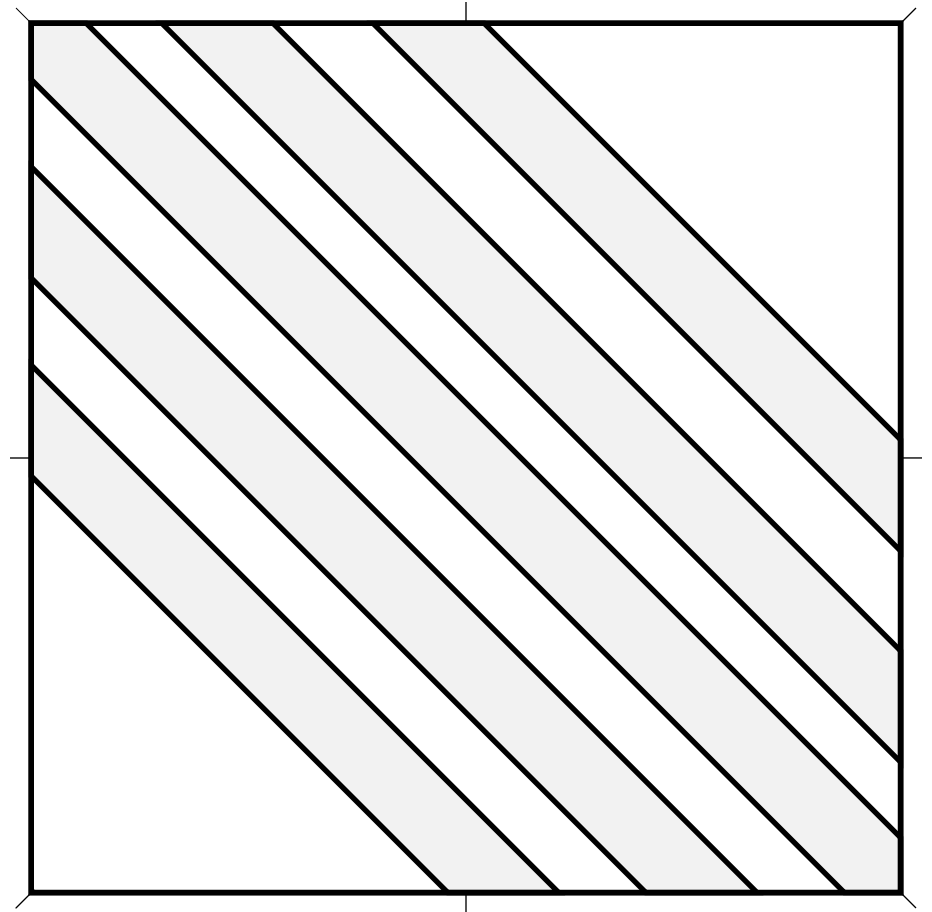
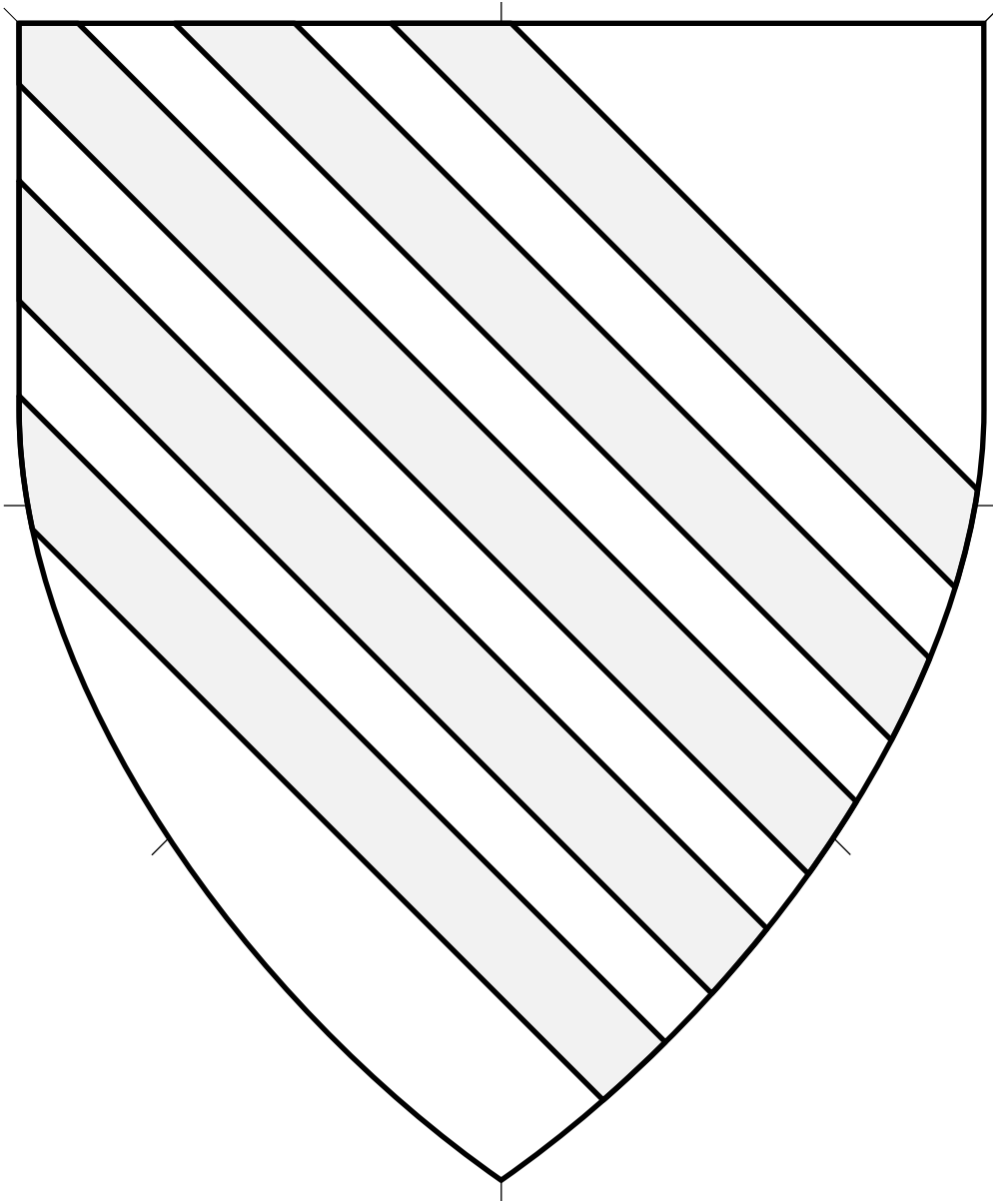

Central ordinary. Diminutive of the bend.

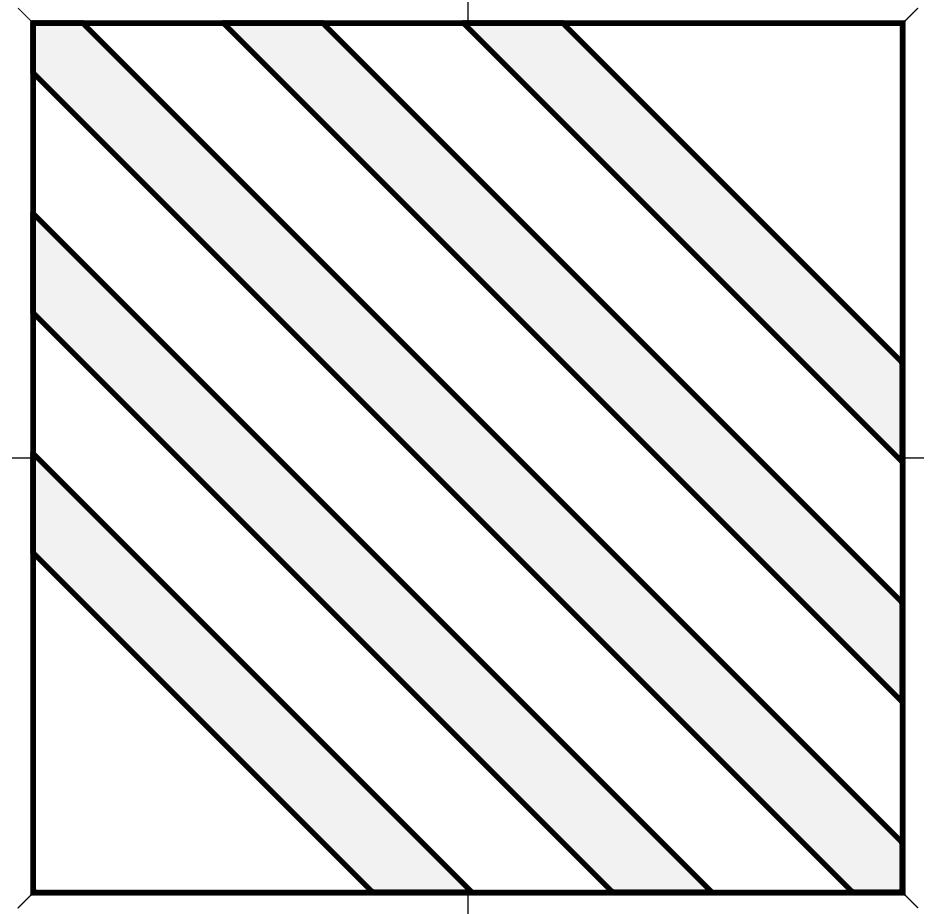
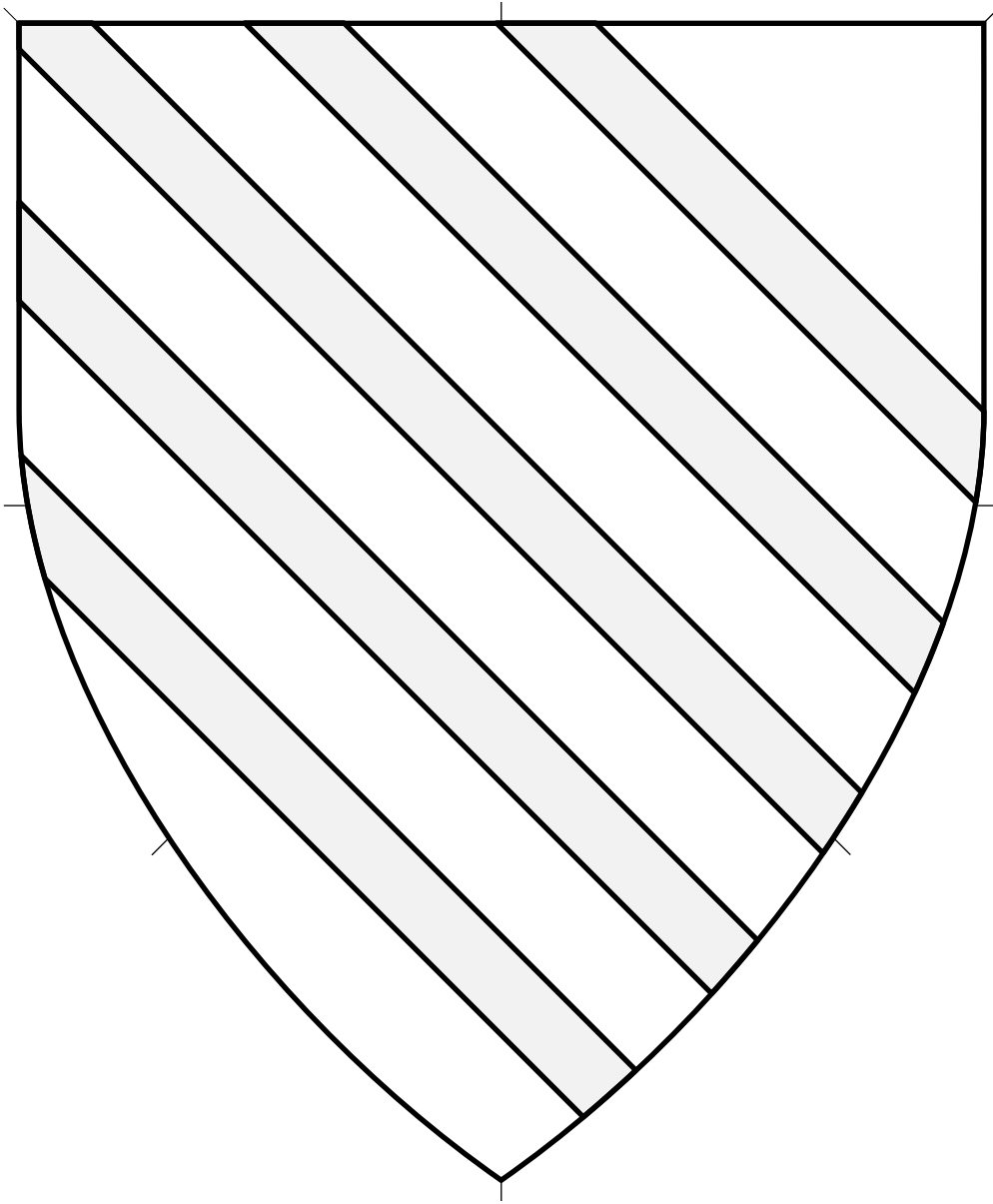

Central ordinary. Diminutive of the bend.

Source: Le Blason des Armes of Claude Nourry. Artist: Claude Nourry.

Bendlets, 5 (2) 4.114

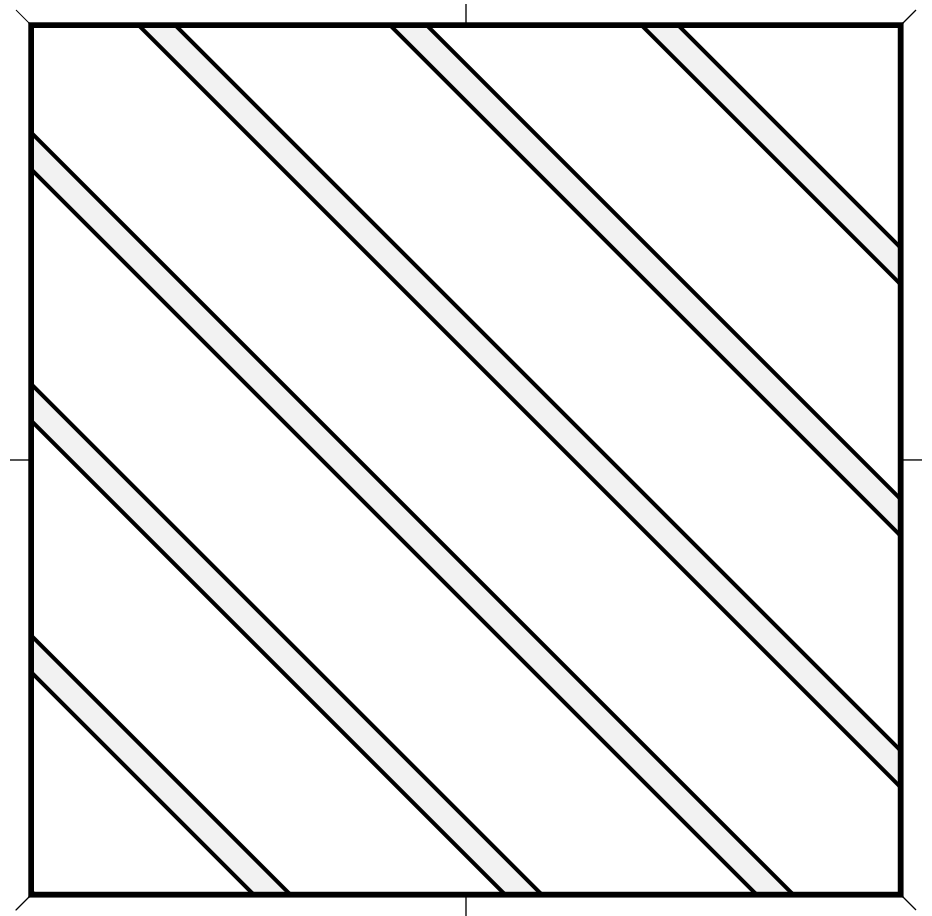
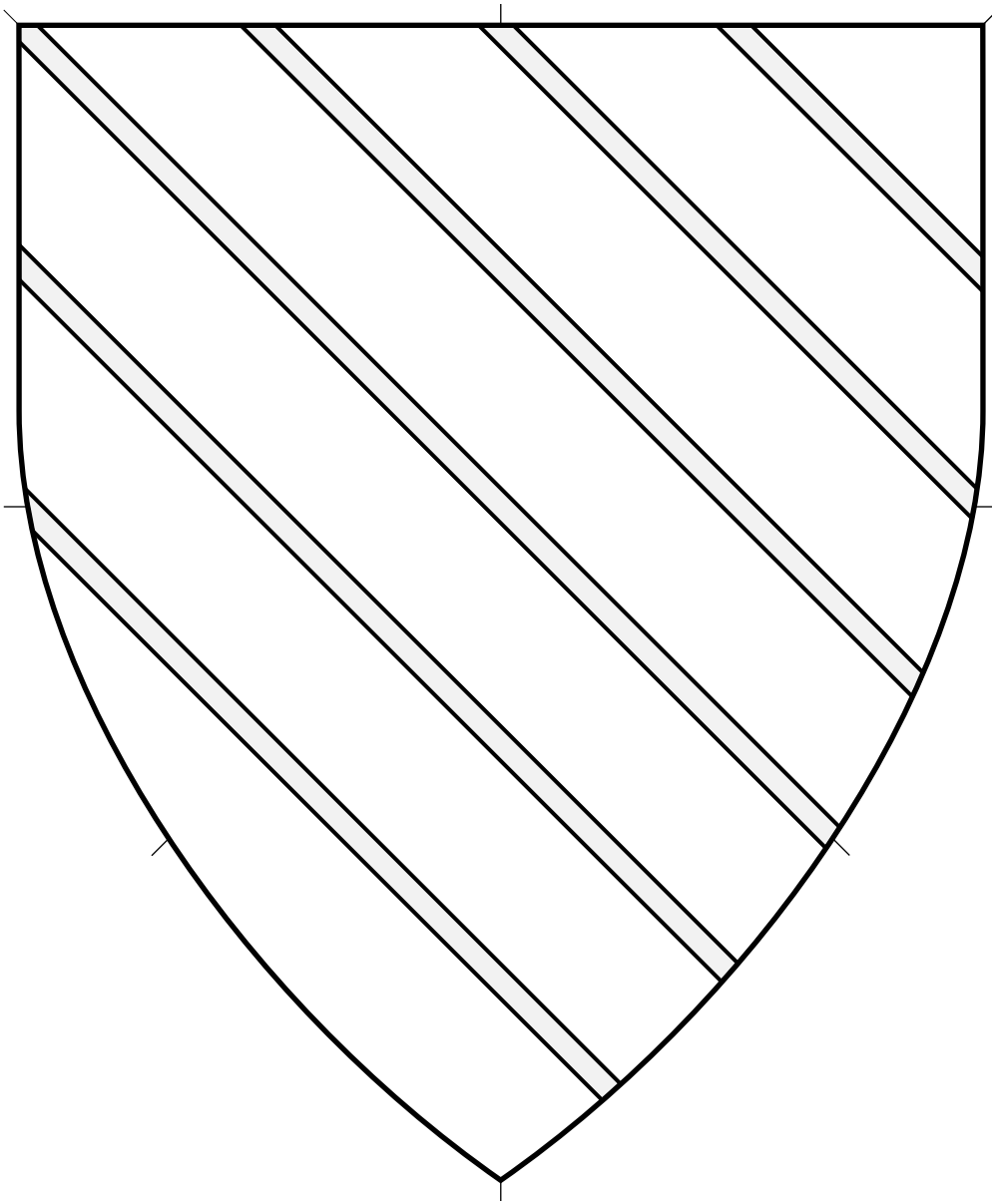

Central ordinary. Diminutive of the bend.

Source: Insignia Equitum Gallici Ordinis Sancti Michaelis.
Artist unknown. (Page 168.)

Bendlets, 6 • 4.115

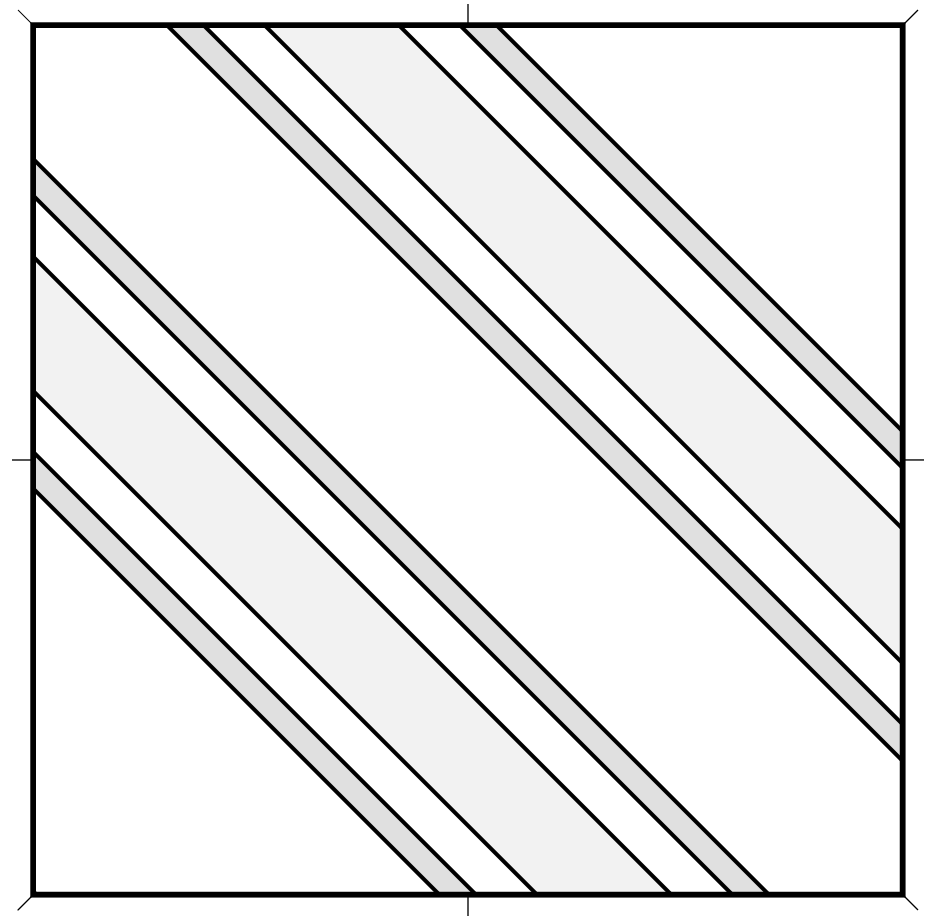
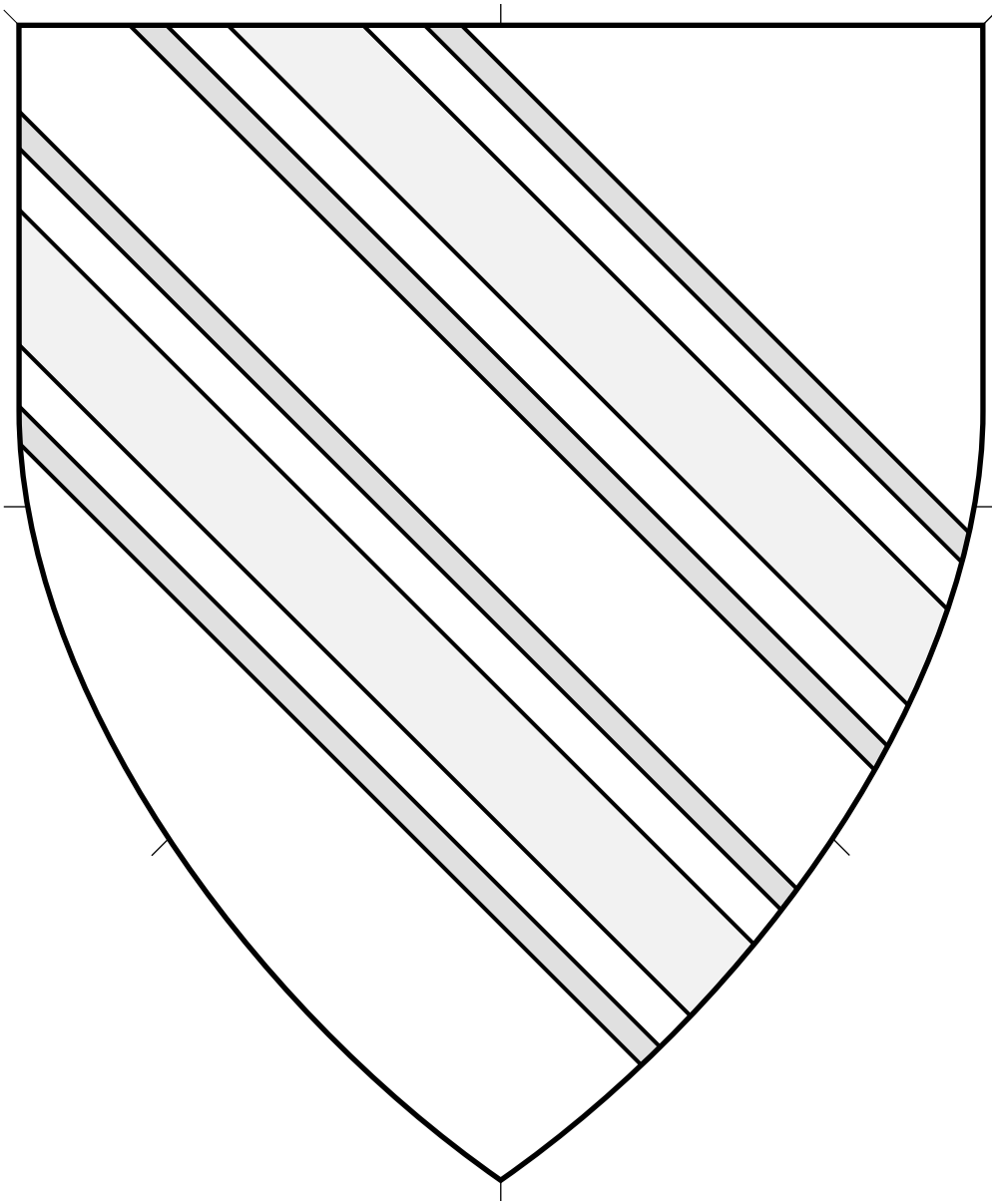

Central ordinary.

Source: Commonplace Book of Heraldry. (Folio 30r.)

Artist: Jean Faucket. Adapted by Mathghamhain Ua Ruadháin.

Bendlets Cotised, Two 4.116

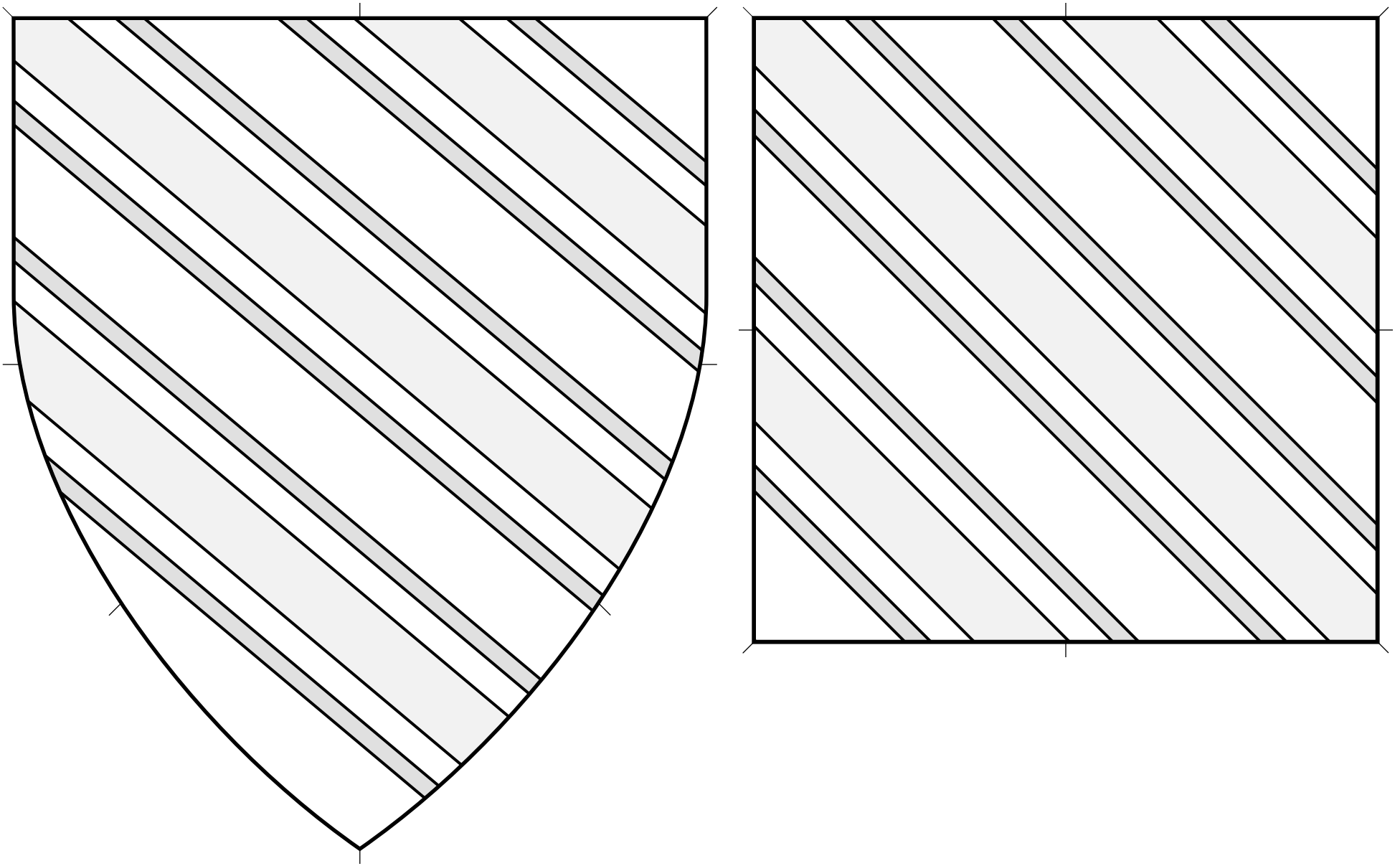

Central ordinary.

Source: Commonplace Book of Heraldry. (Folio 30r.)

Artist: Jean Faucket. Adapted by Mathghamhain Ua Ruadháin.

Bendlets Cotised, Three (1) 4.117

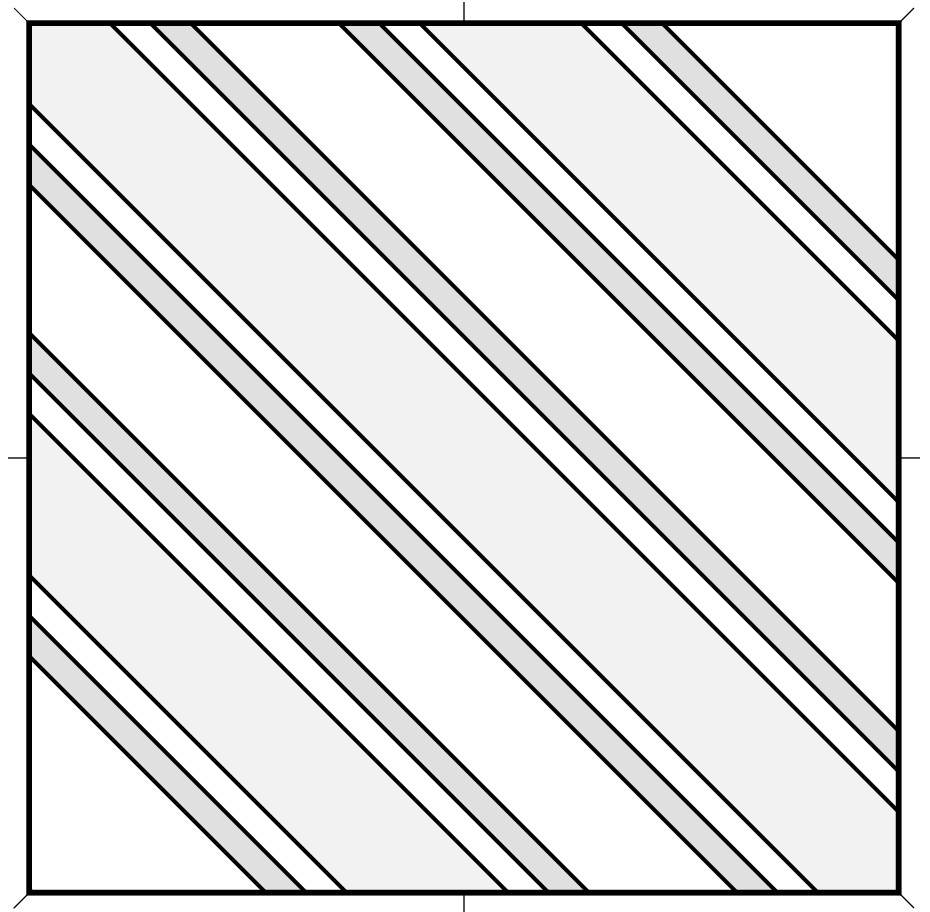
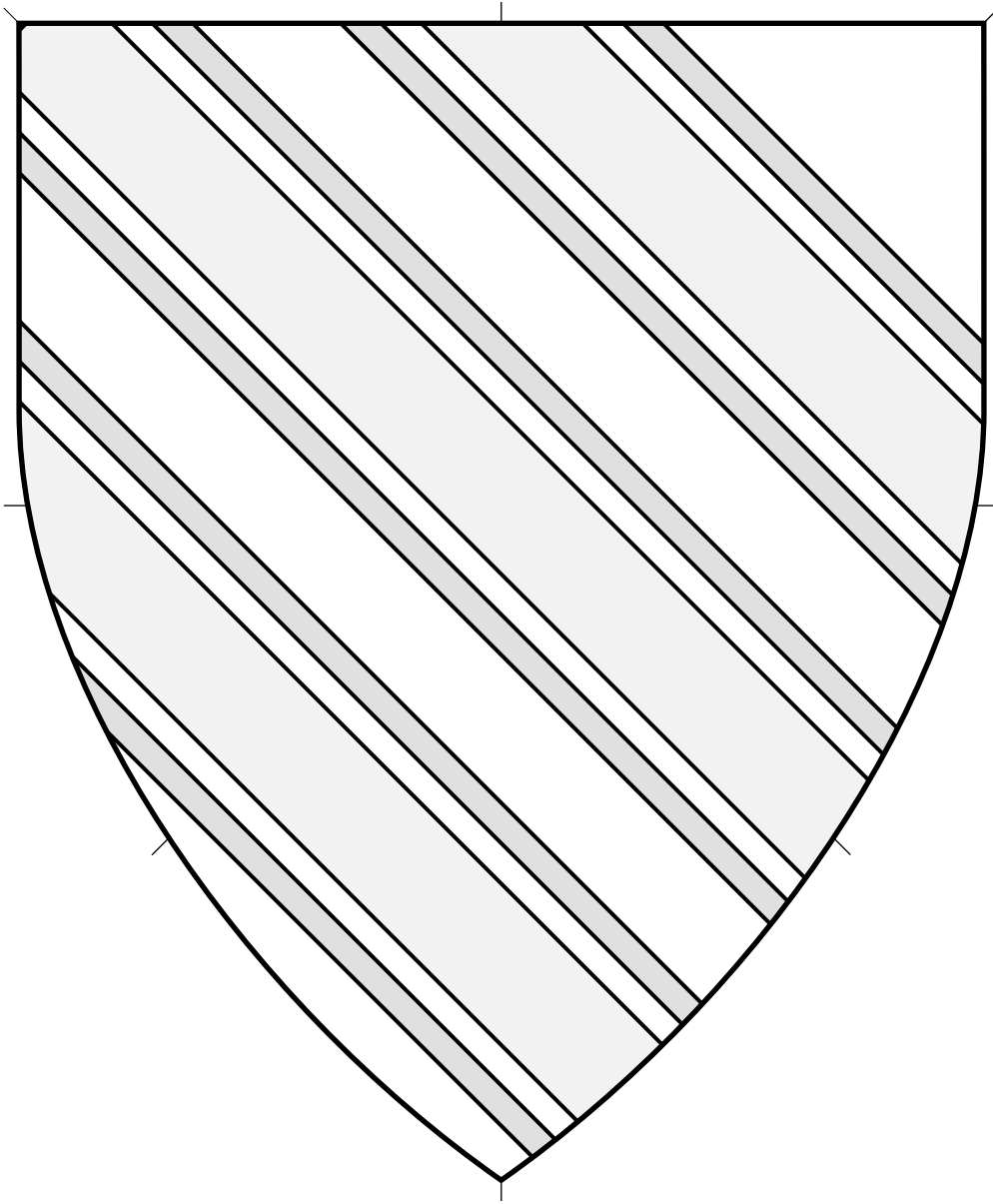

Central ordinary.

Source: Le Grand Armorial Équestre de la Toison d'Or.
Artist unknown. (Folio 76r.)

Bendlets Cotised, Three (2) 4.118

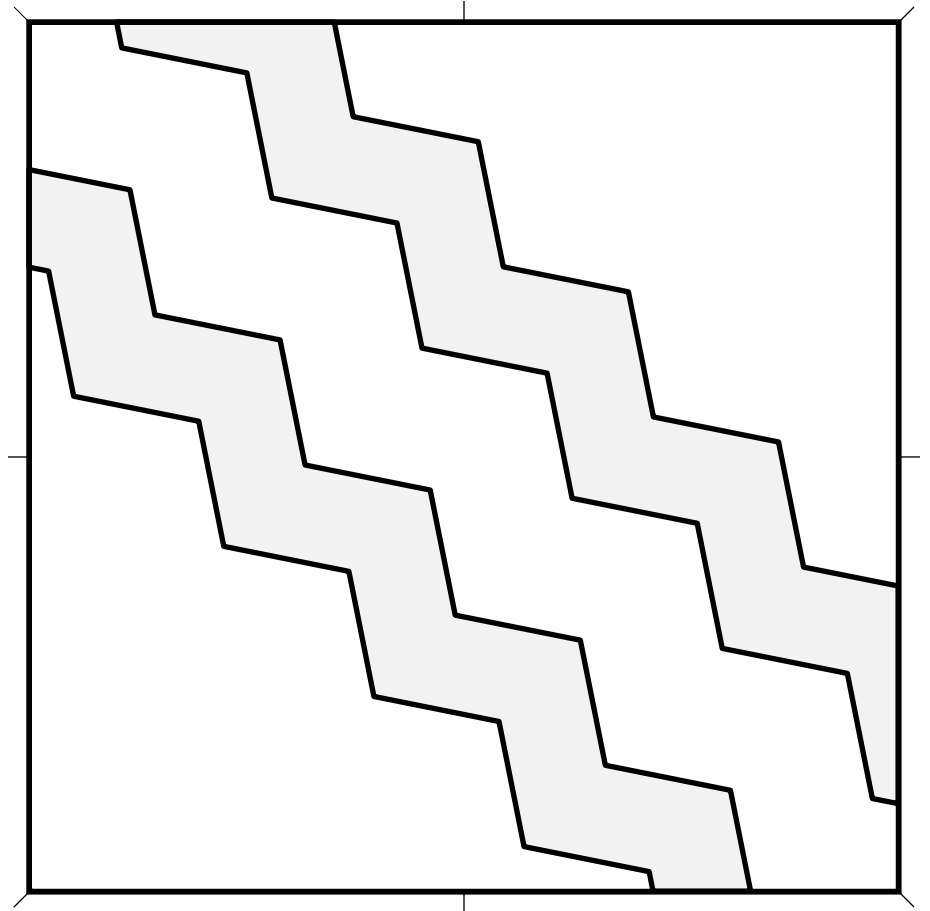
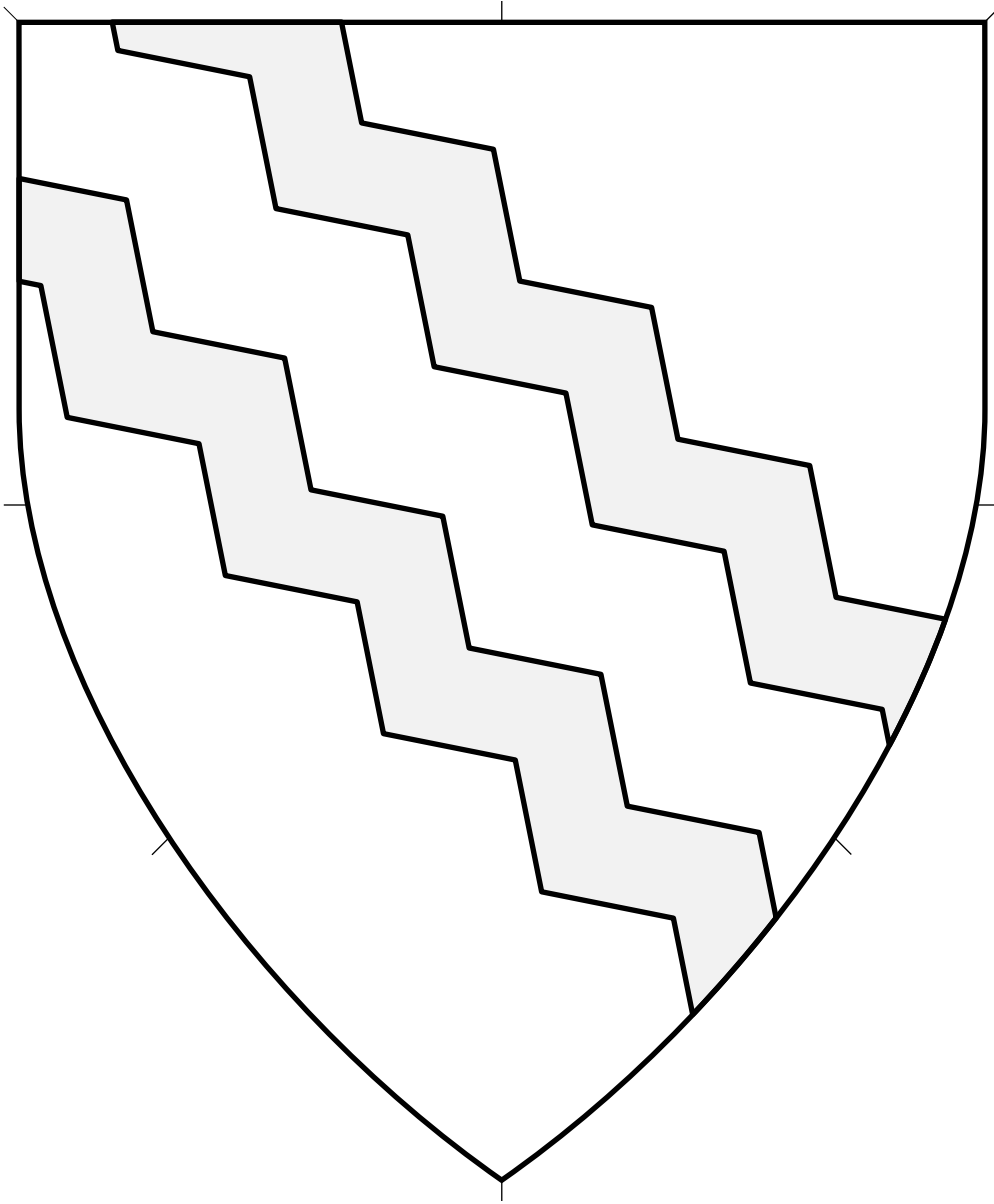

Central ordinary.

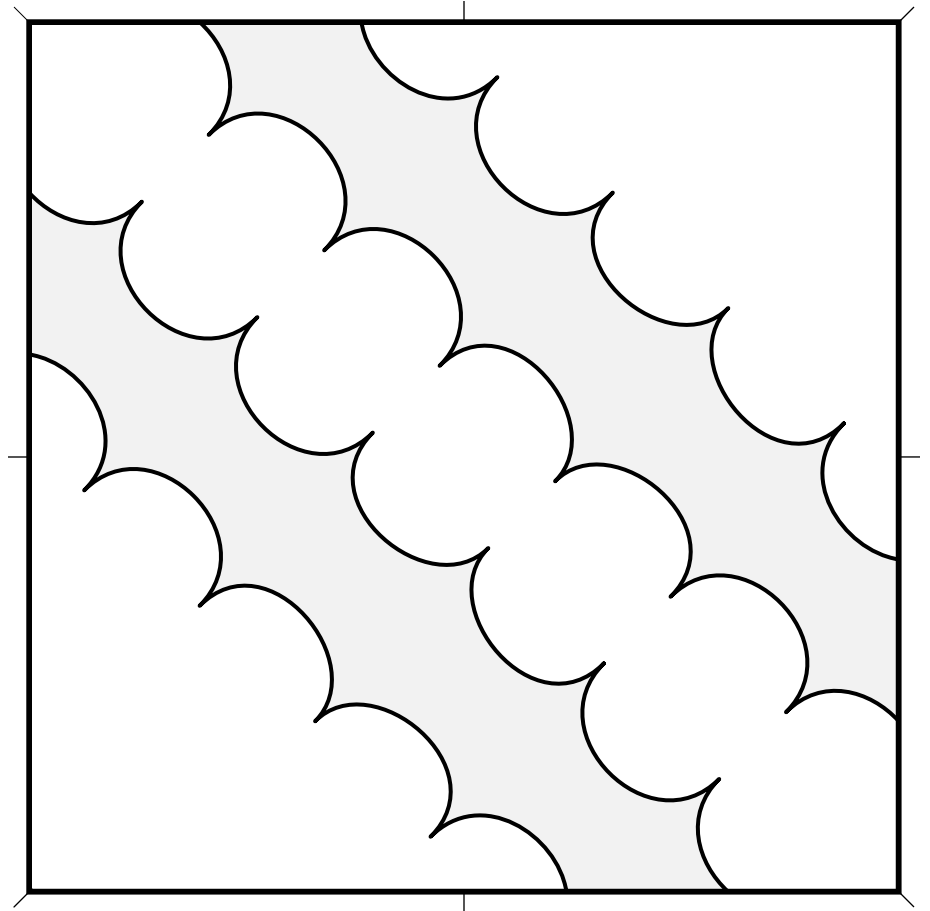
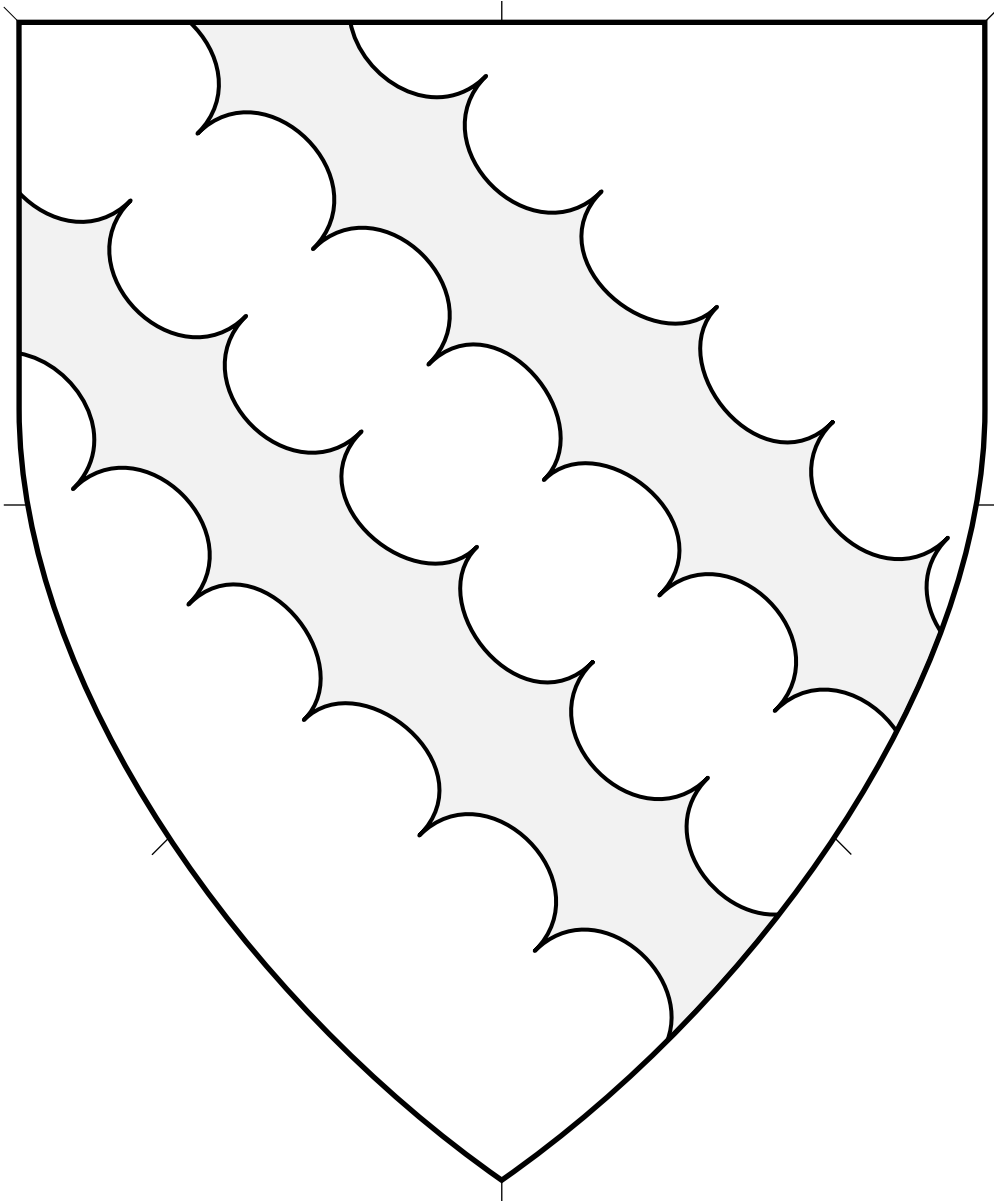

Central ordinary.

Bendlets Engrailed, 2 (1) 4.120

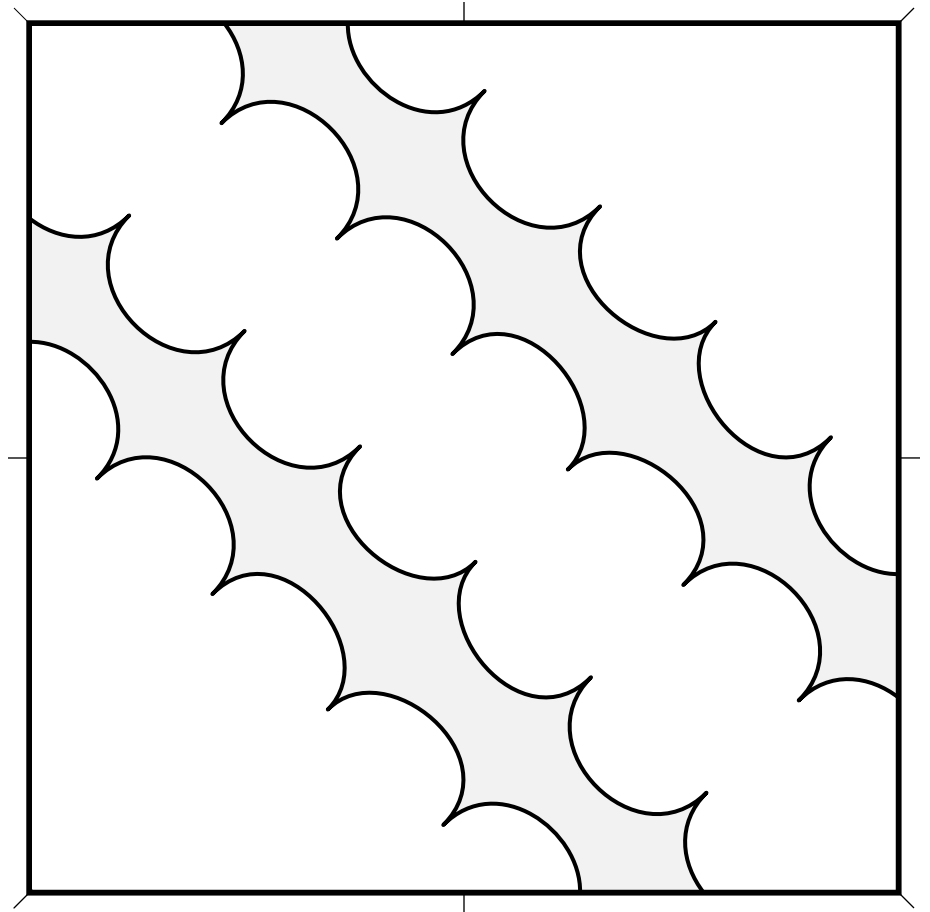
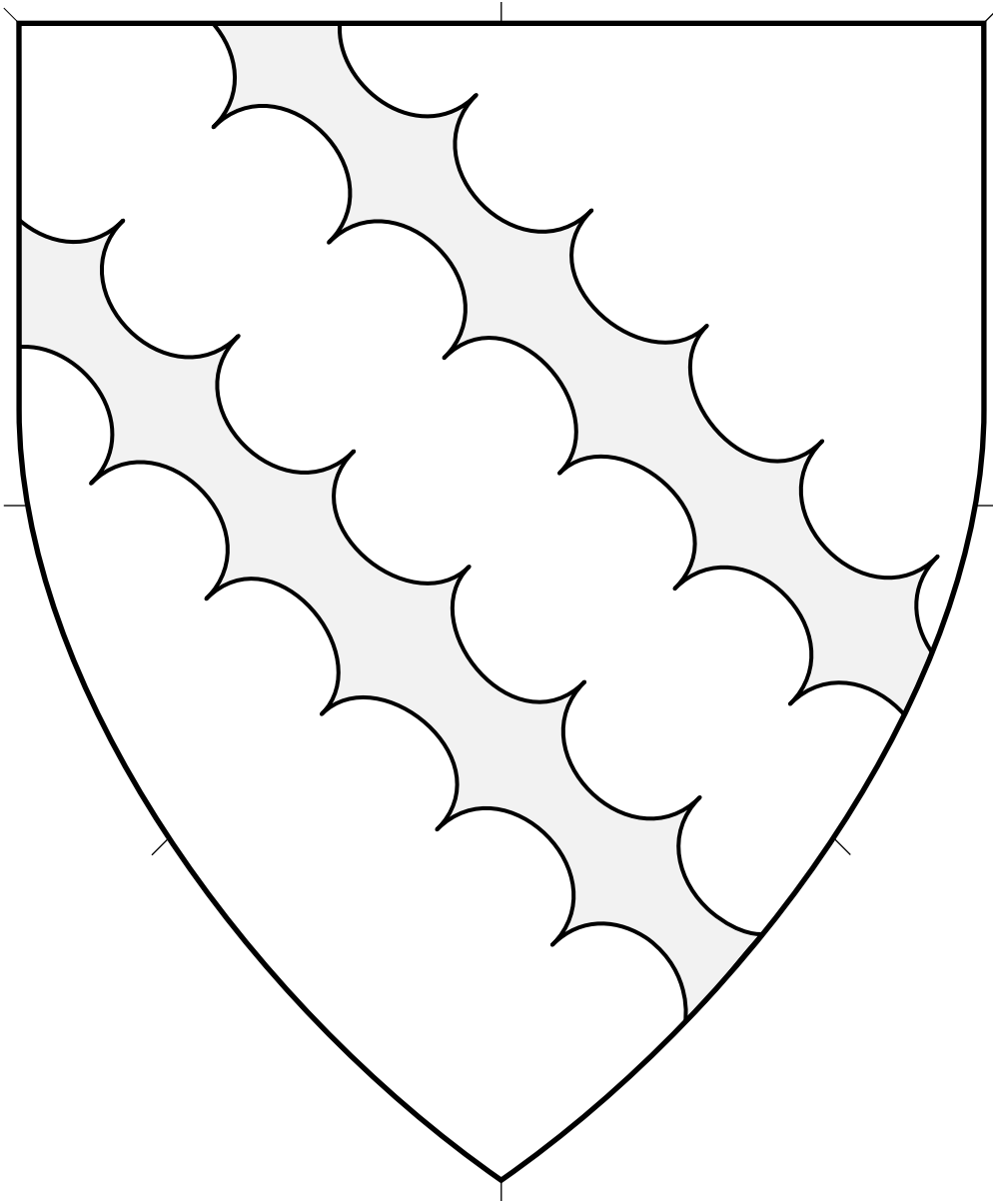

Central ordinary.

Bendlets Engrailed, 2 (2) 4.121

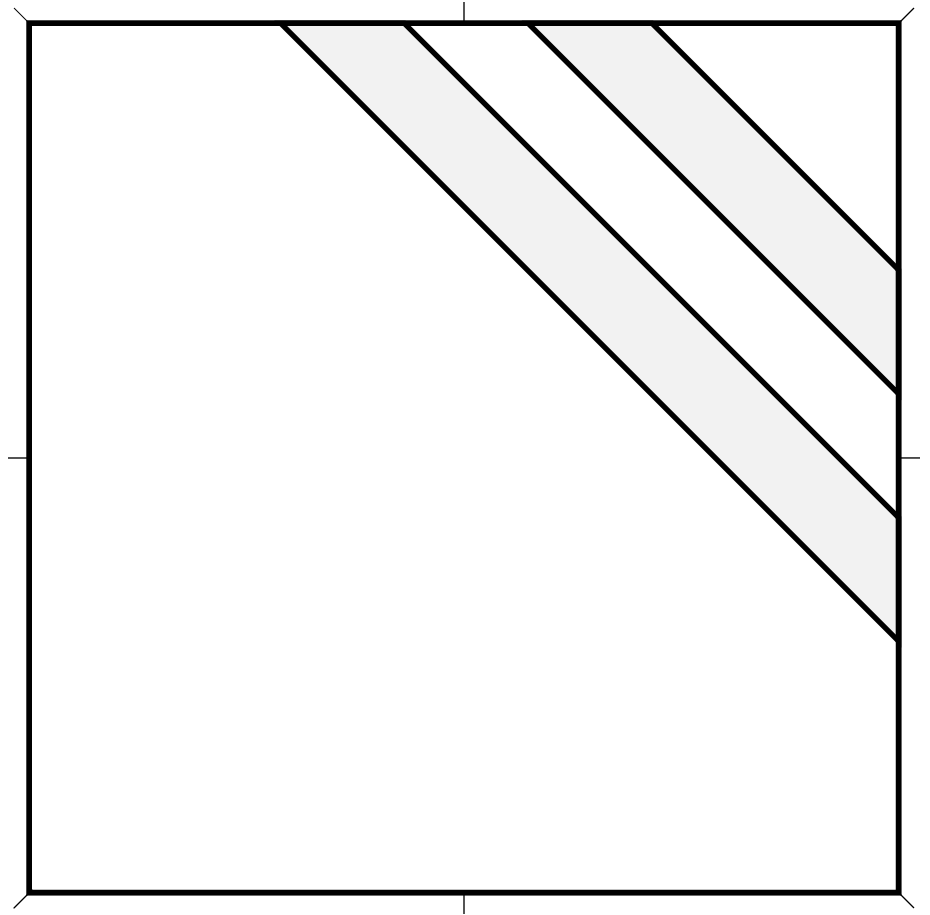
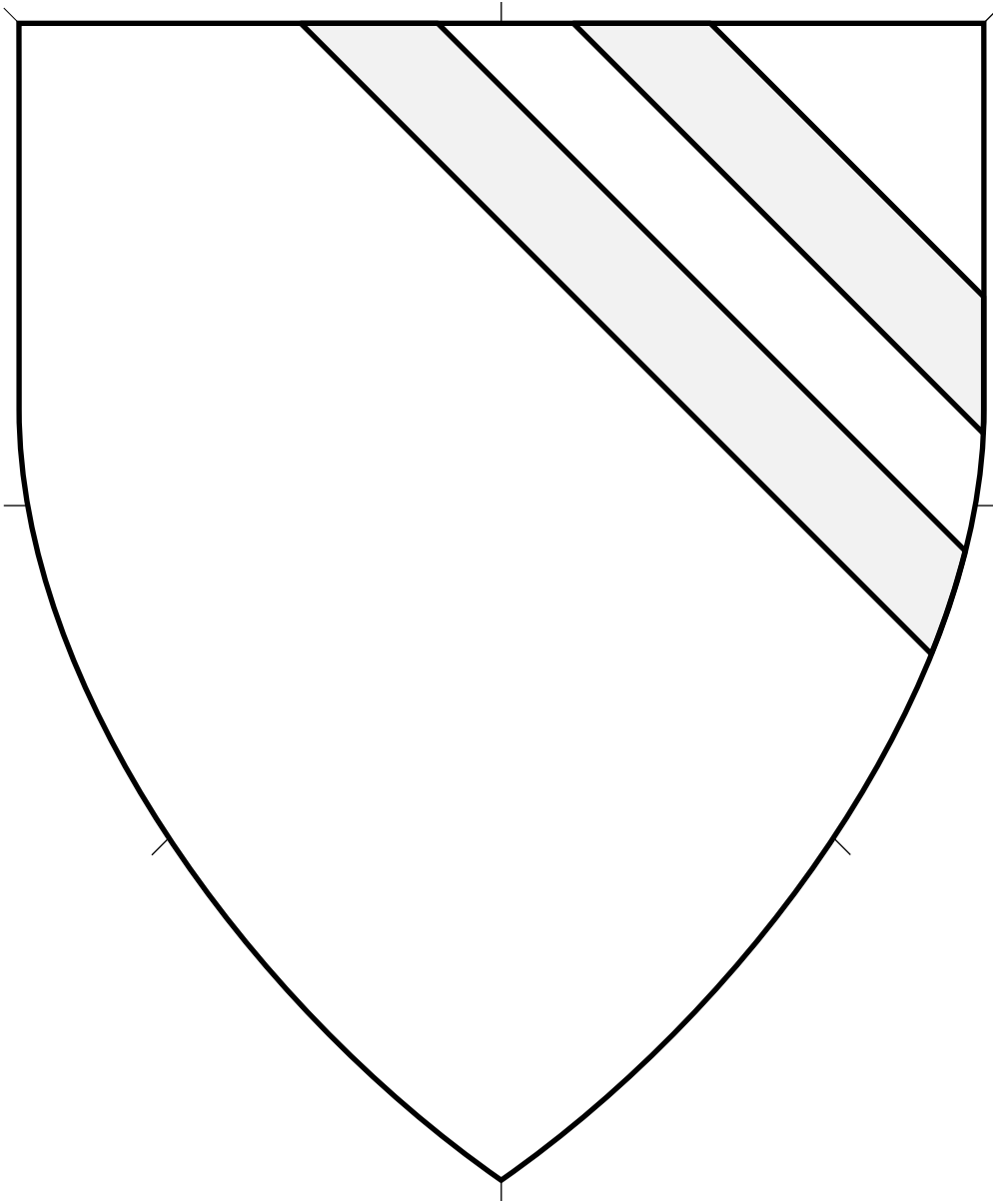

Central ordinary. Diminutive of the bend.

Use of bendlets enhanced with any other charge would be considered a step from core practice (SFCP).

Bendlets Enhanced, 2 (1) 4.122

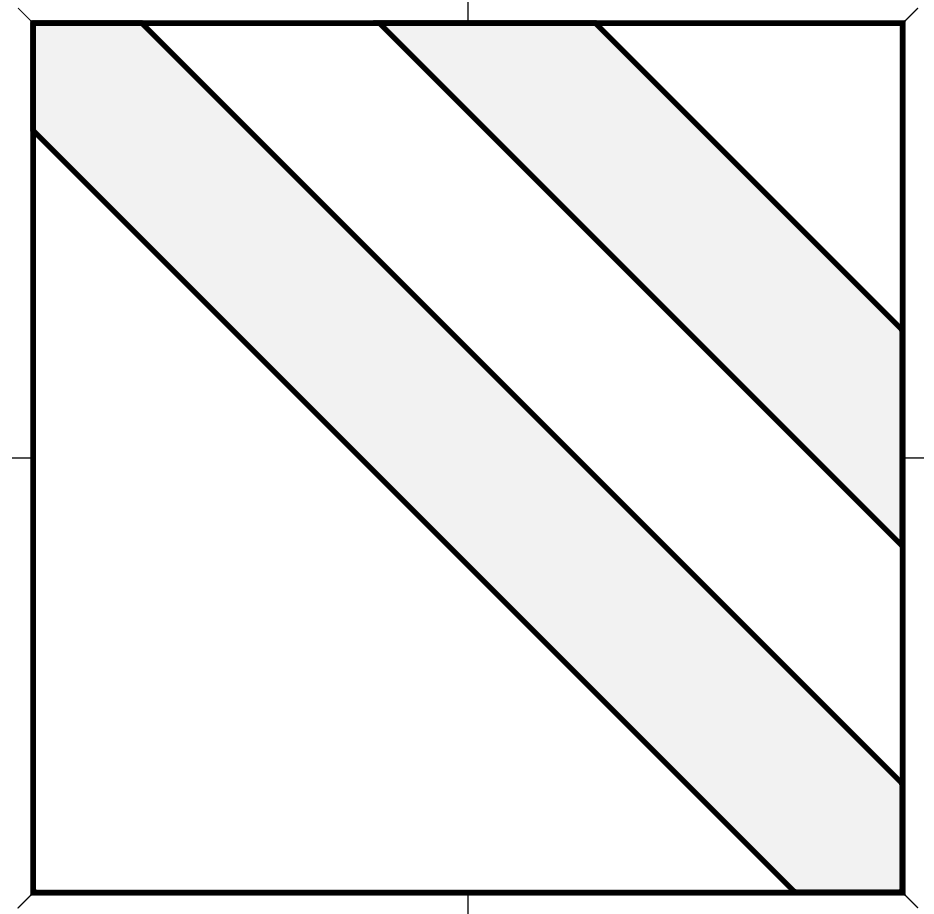
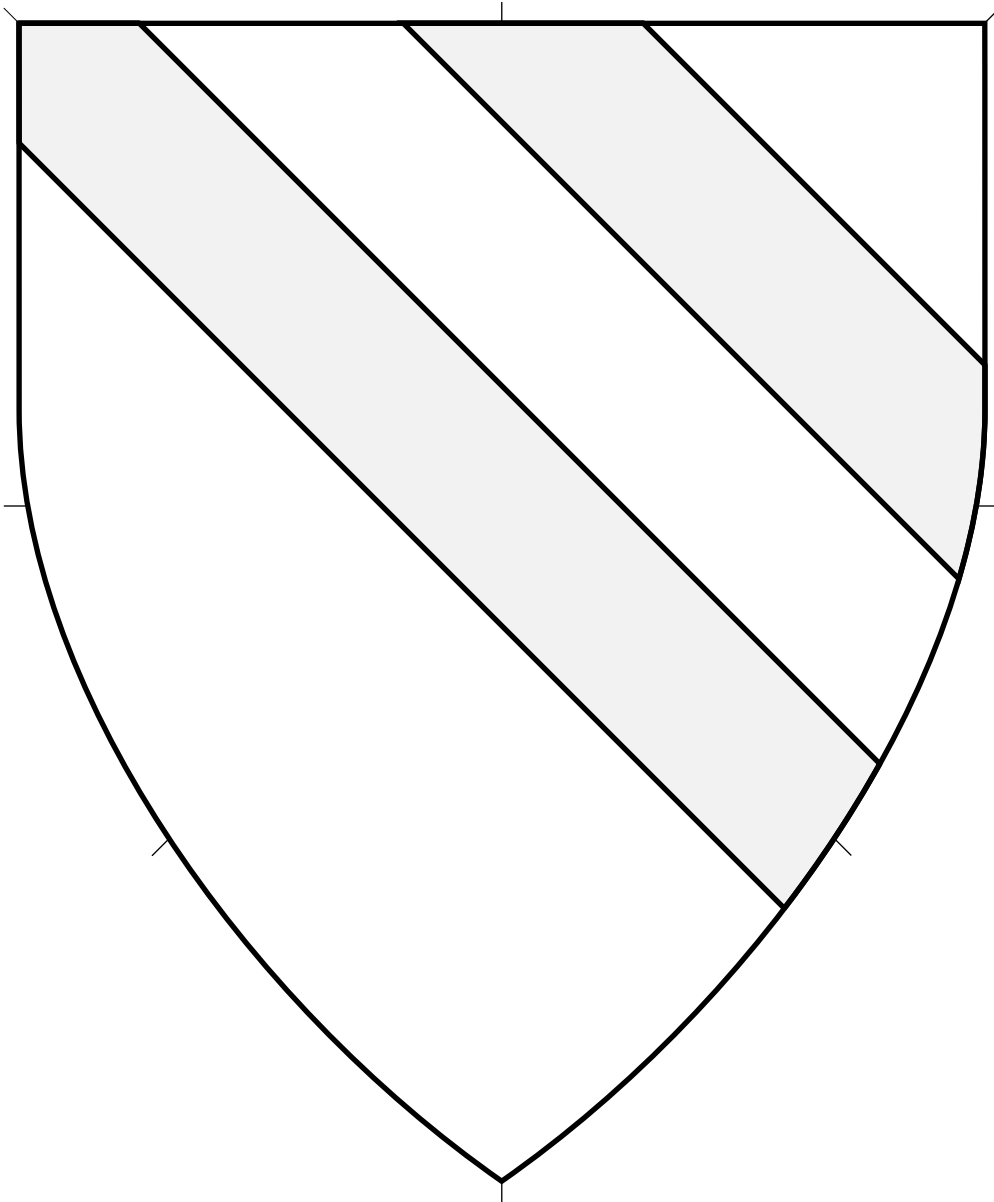

Central ordinary. Diminutive of the bend.

Use of bendlets enhanced with any other charge would be considered a step from core practice (SFCP).

Source: Armas de los Cavalleros de Venecia.
Artist unknown. (Folio 56r.)

Bendlets Enhanced, 2 (2) 4.123

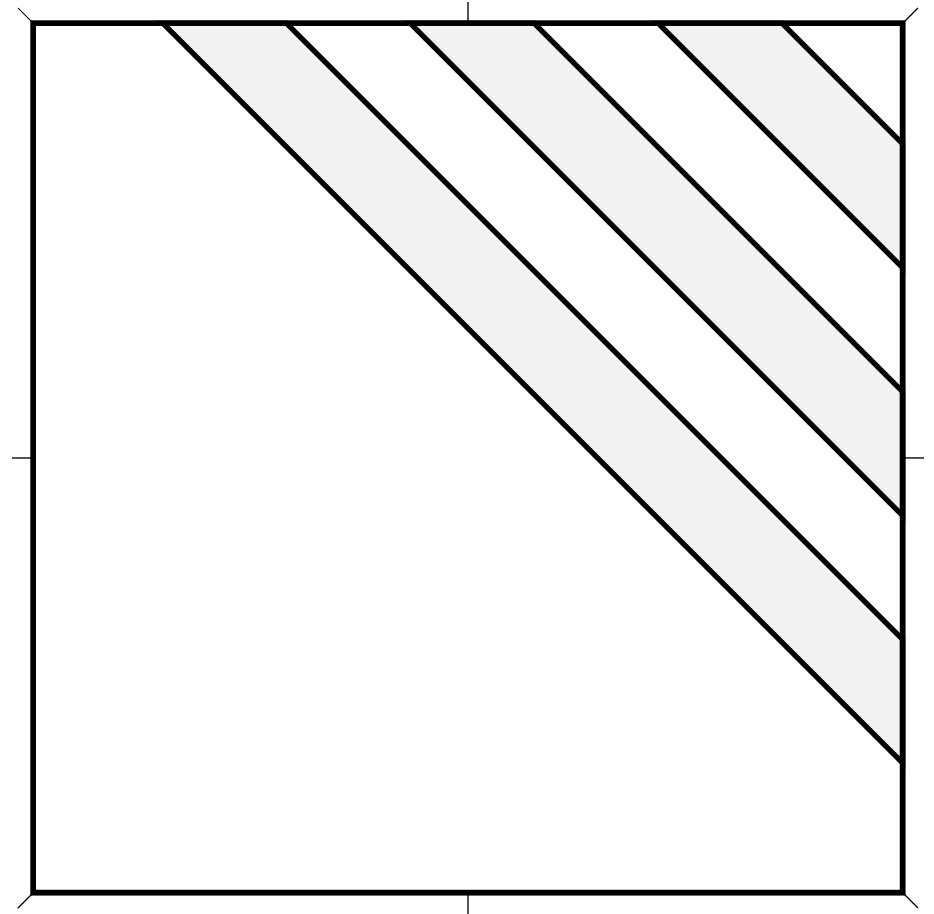
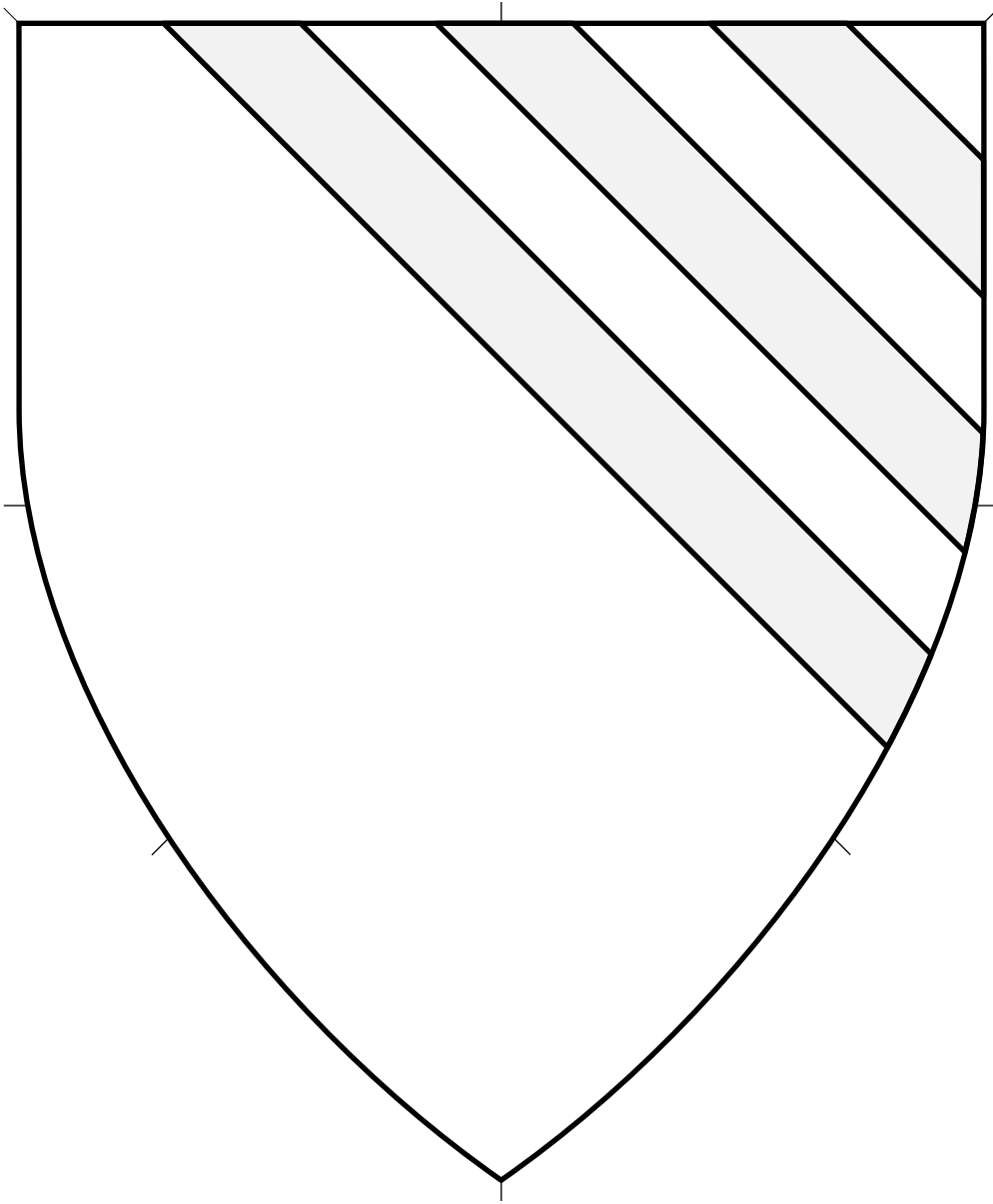

Central ordinary. Diminutive of the bend.

Use of bendlets enhanced with any other charge would be considered a step from core practice (SFCP).

Bendlets Enhanced, 3 4.124

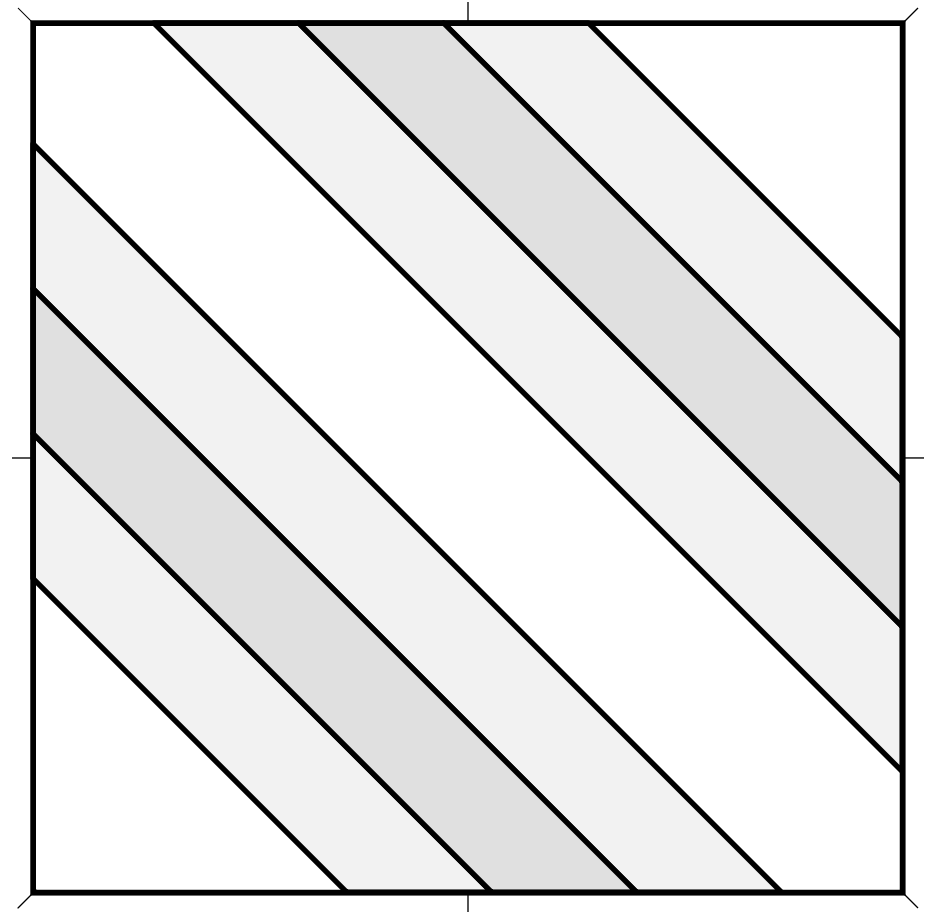
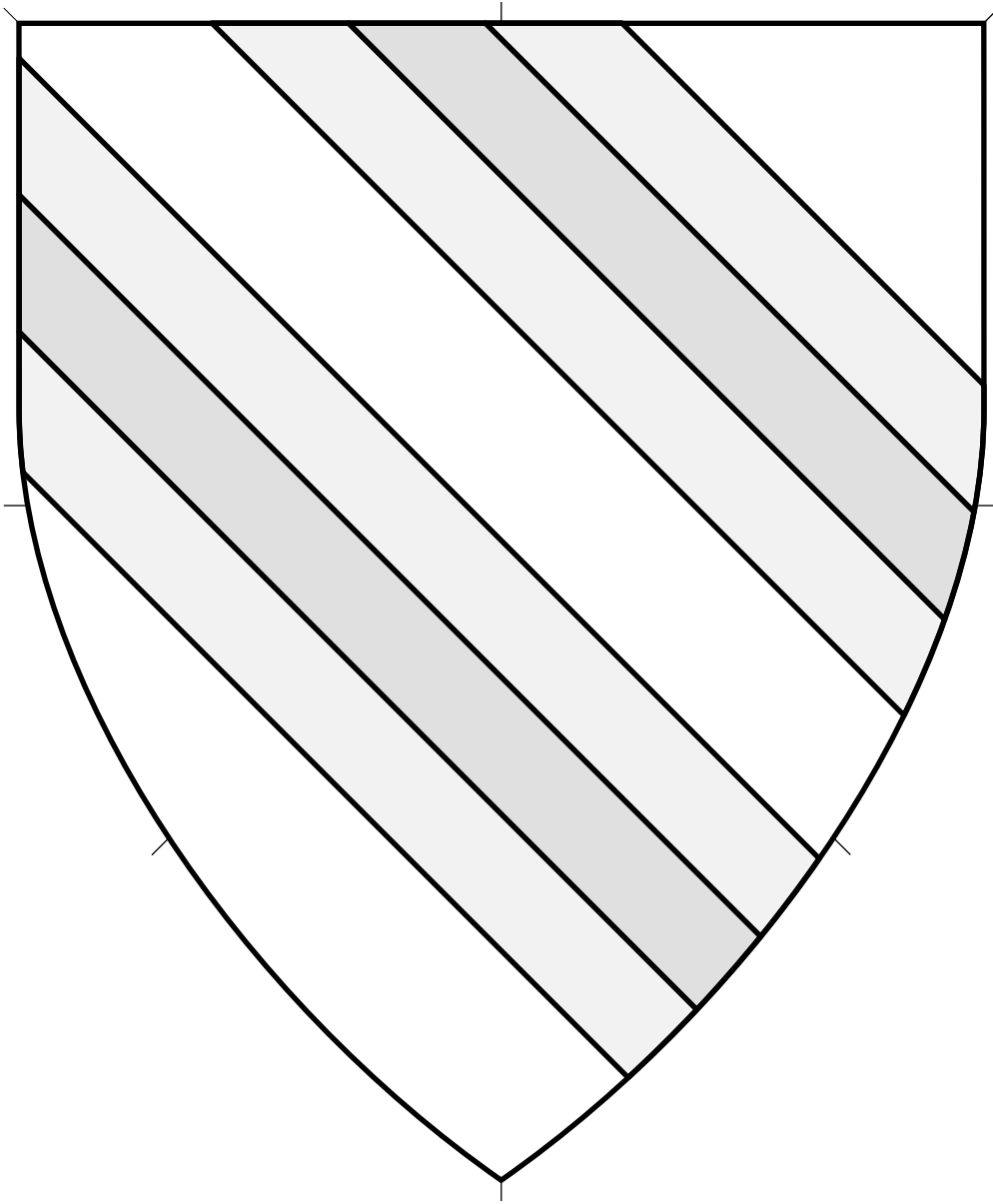

Central ordinary.

Source: Armorial Français et Plus Particulièrement Poitevin. Artist unknown. (Folio 33r.)

Bendlets Fimbriated, Two (1) 4.125

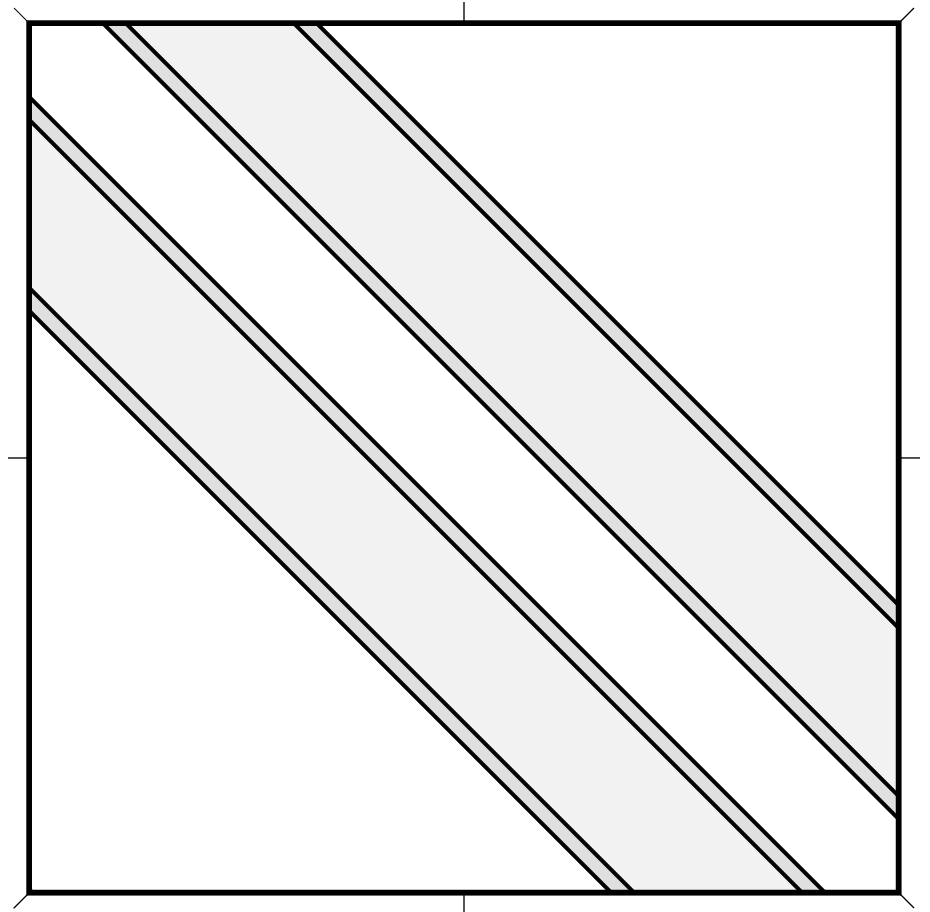
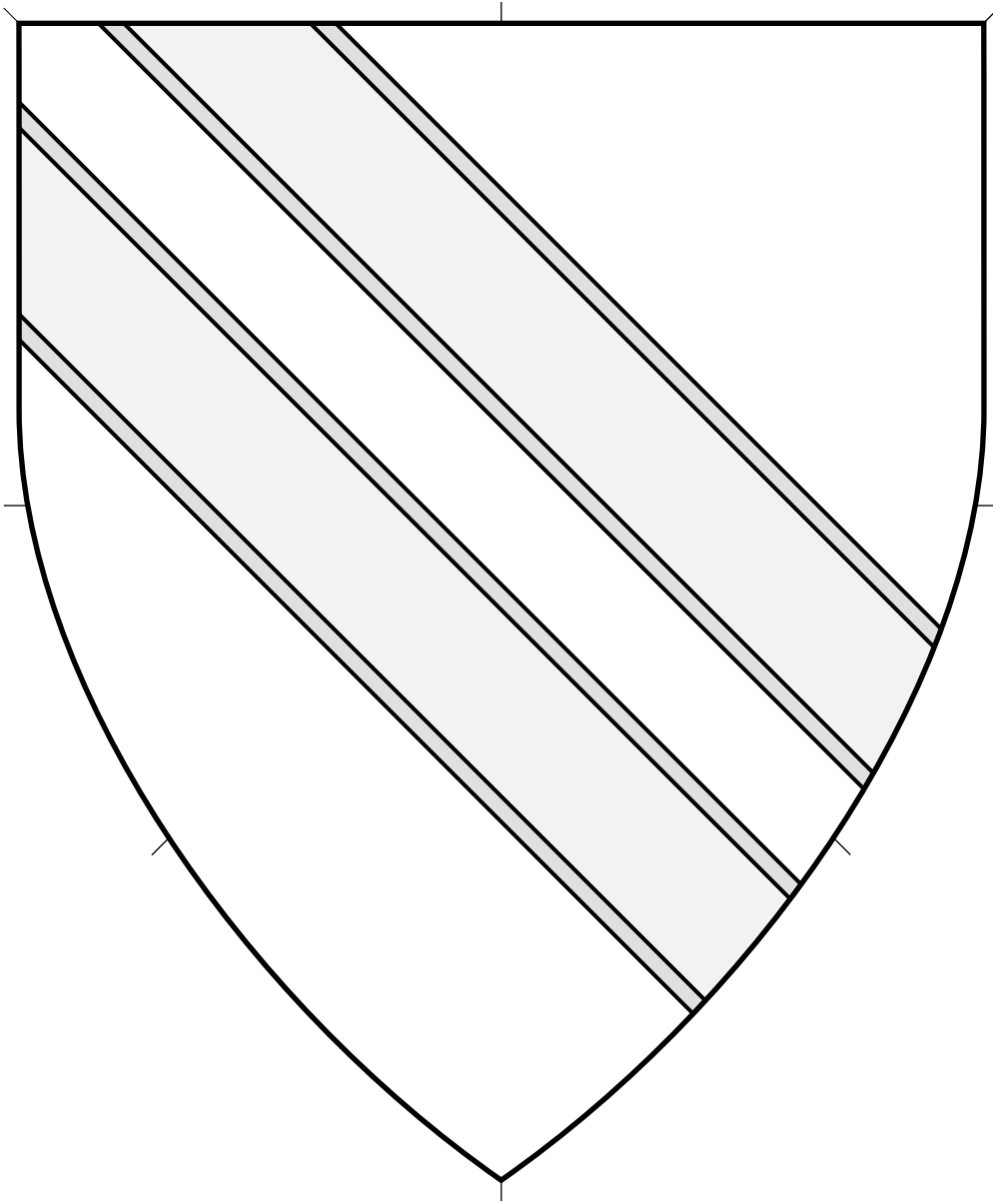

Central ordinary.

Bendlets Fimbriated, Two (2) 4.126

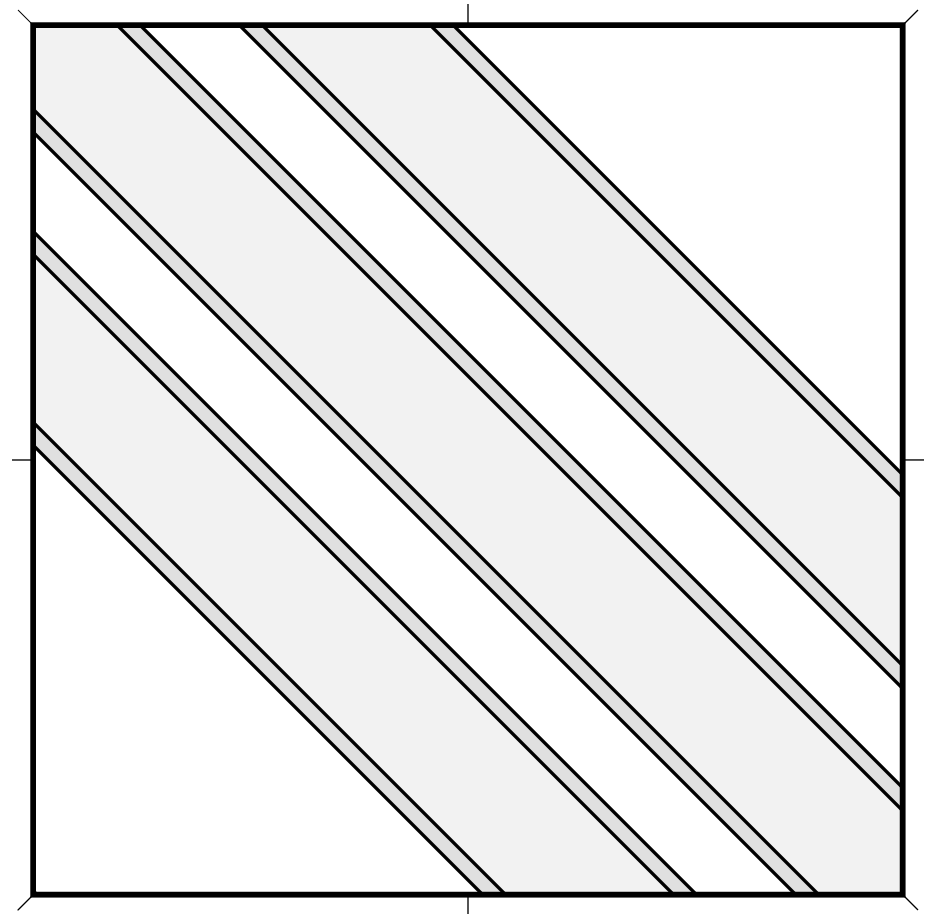
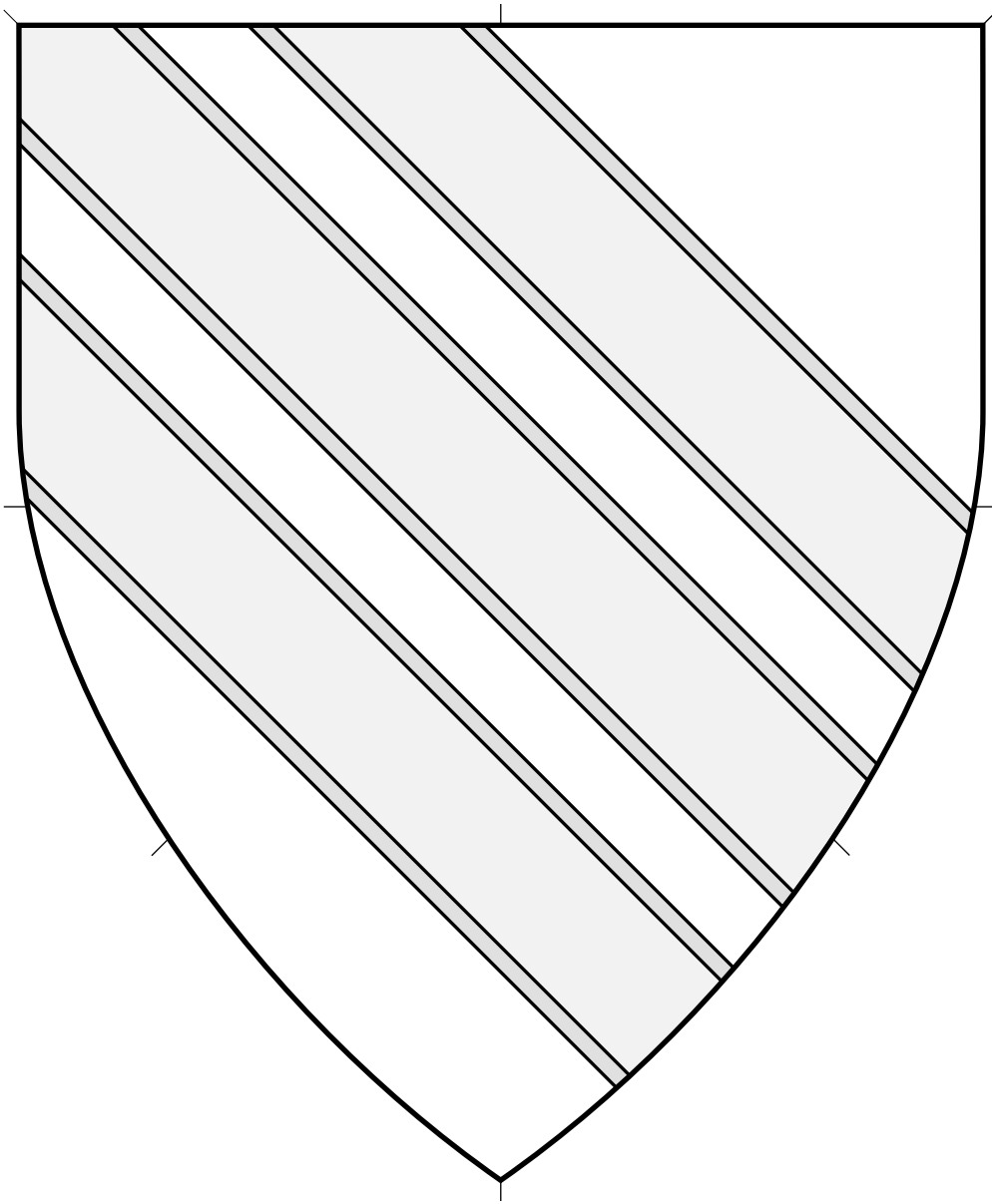

Central ordinary.

Bendlets Fimbriated, Three 4.127

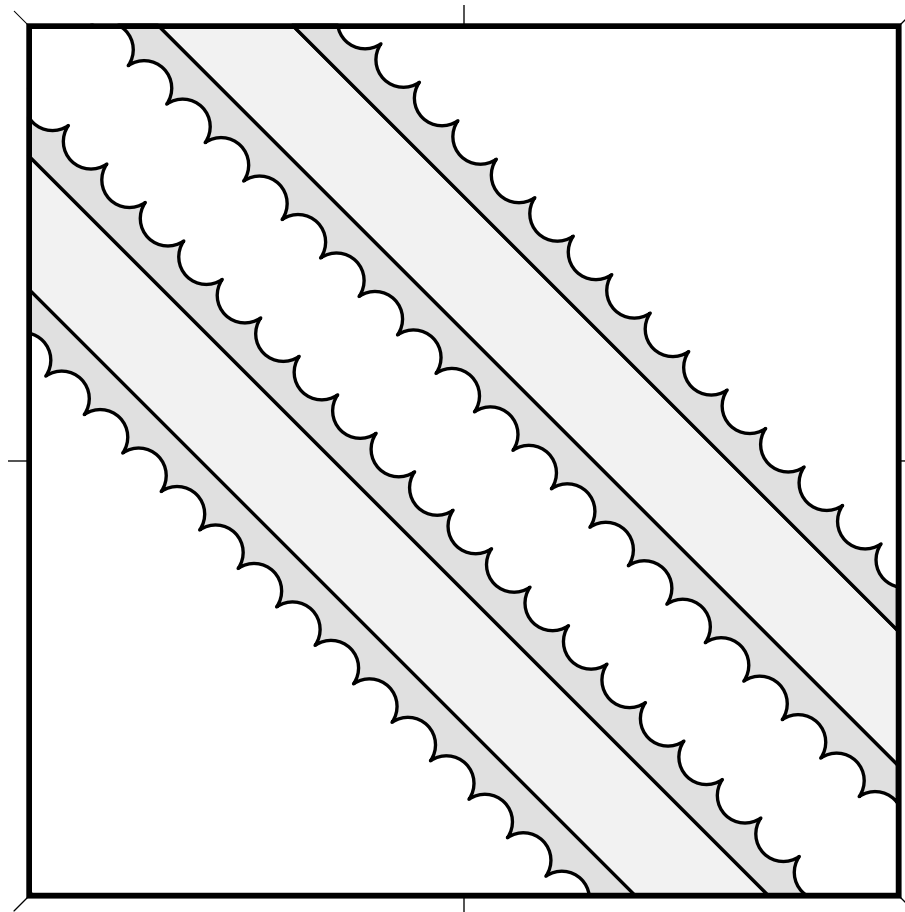
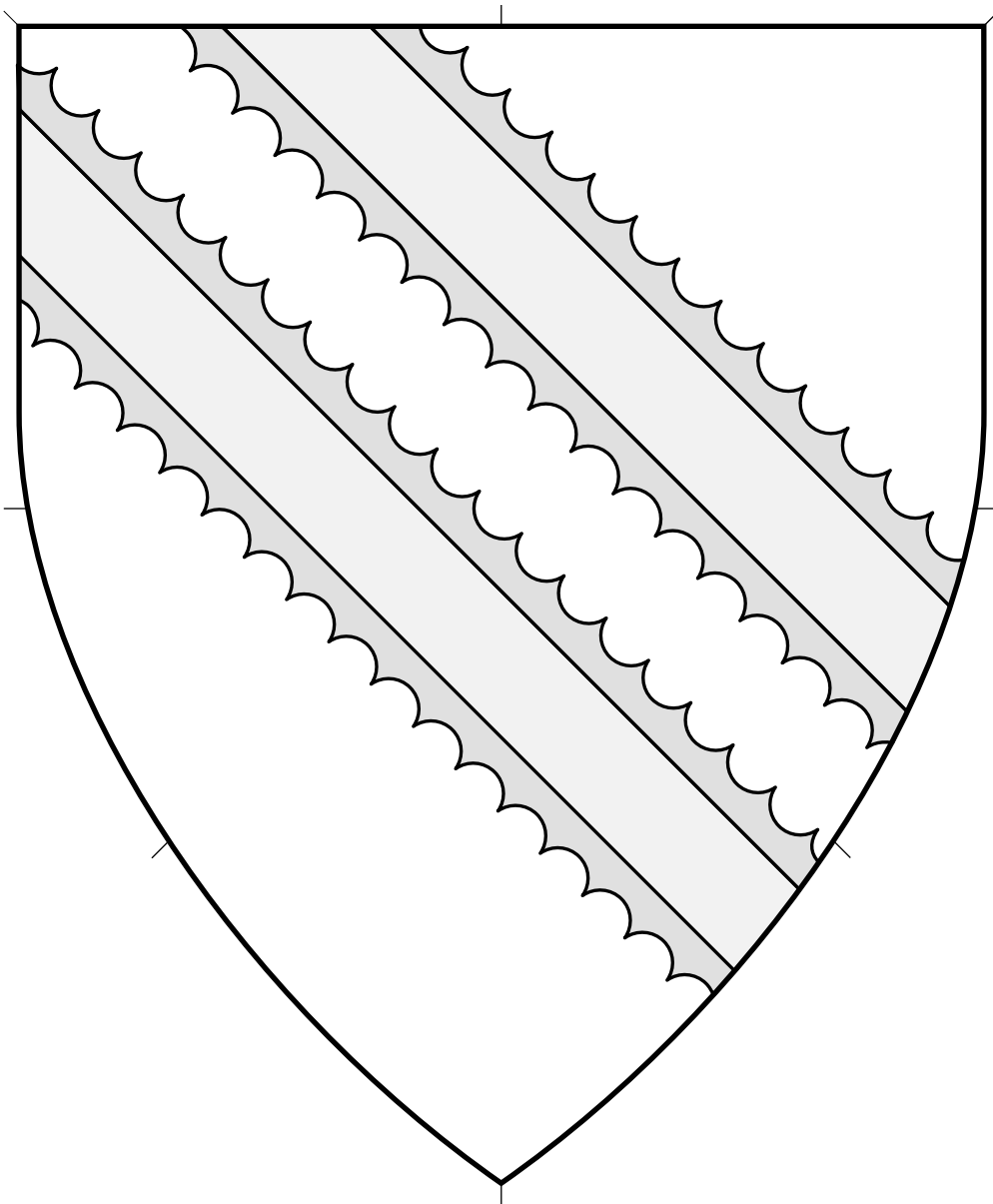

Central ordinary.

Source: BnF MS Fr 18649.

Artist unknown.

Bendlets Fimbriated Engrailed, Two (1) 4.128

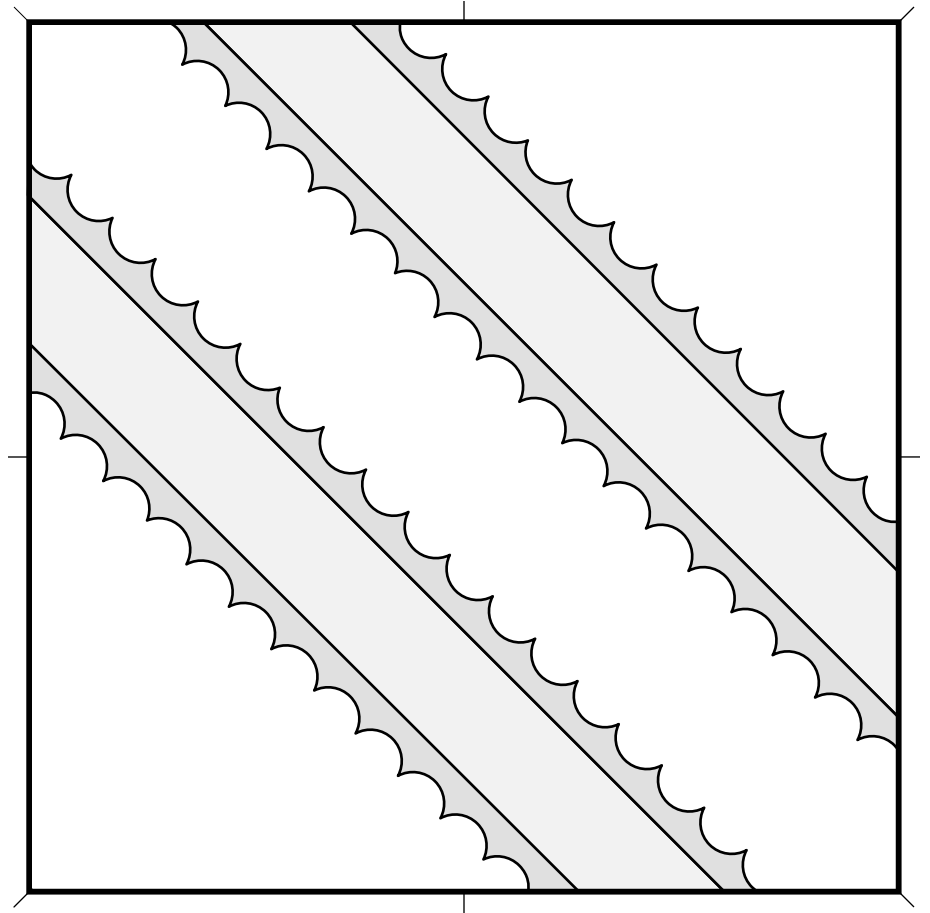
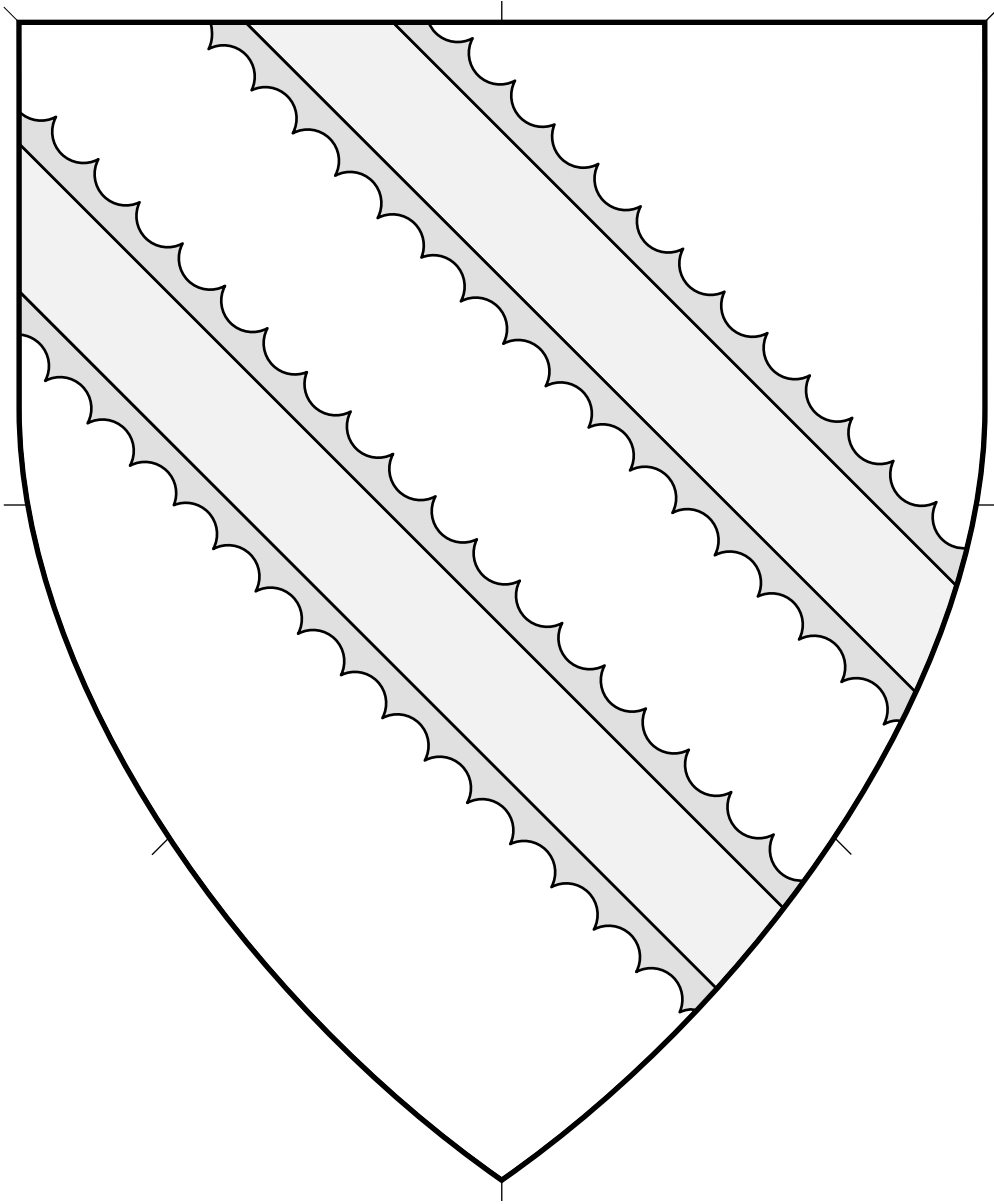

Central ordinary.

Source: Armorial Lorrain de la Première Moitié du XVIe Siècle. (Page 150.) Artist unknown.

Bendlets Fimbriated Engrailed, Two (2) 4.129

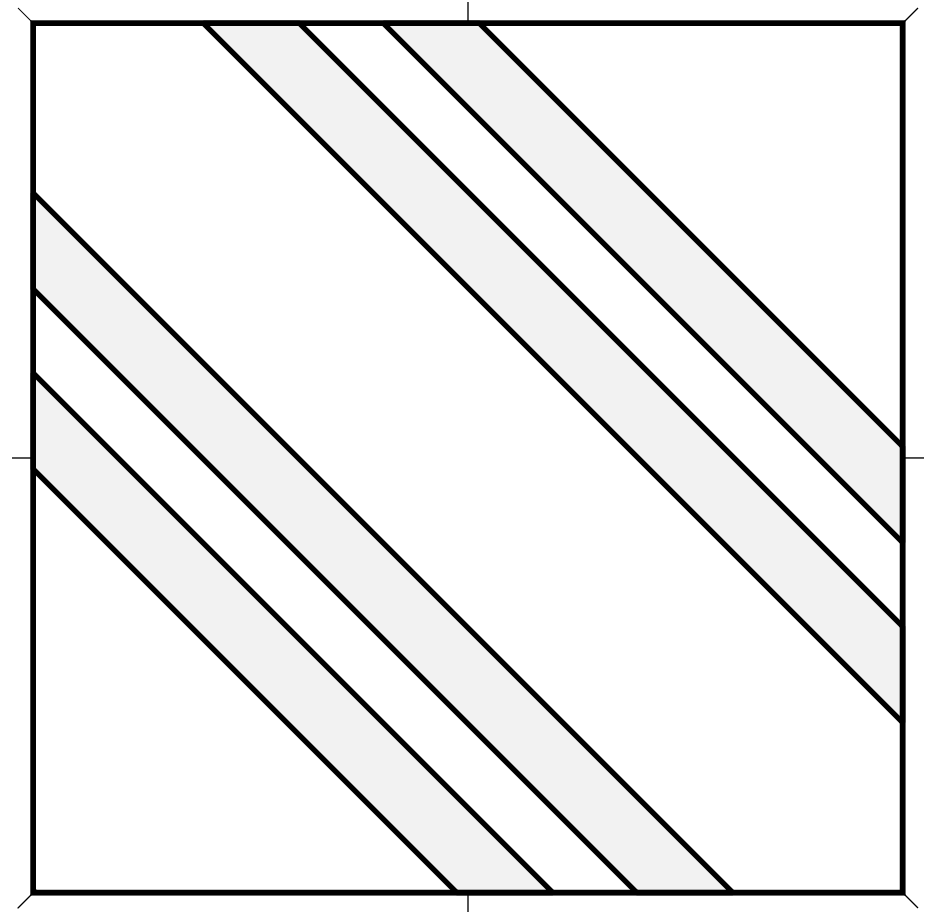
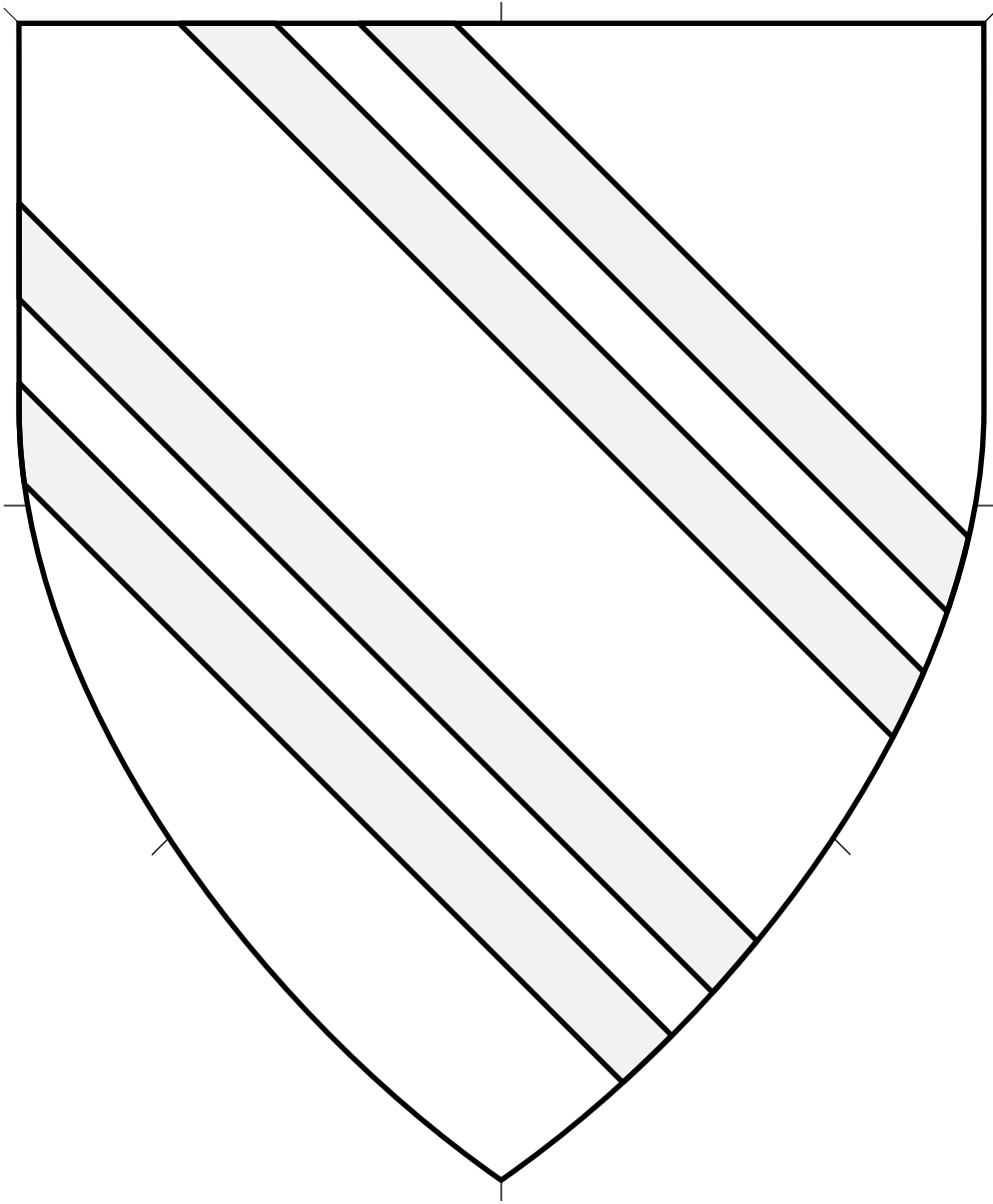

Central ordinary.
Two pairs of bendlets separated by a gap.

Bendlets Gemel, Two (1) 4.130

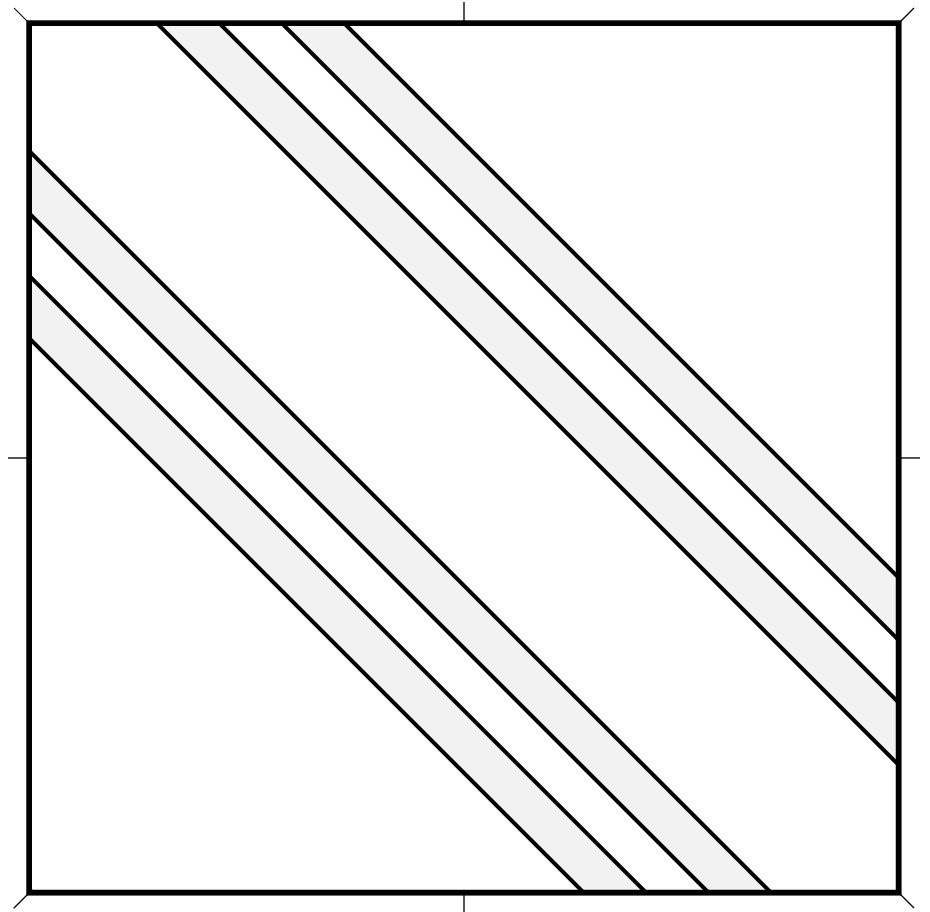
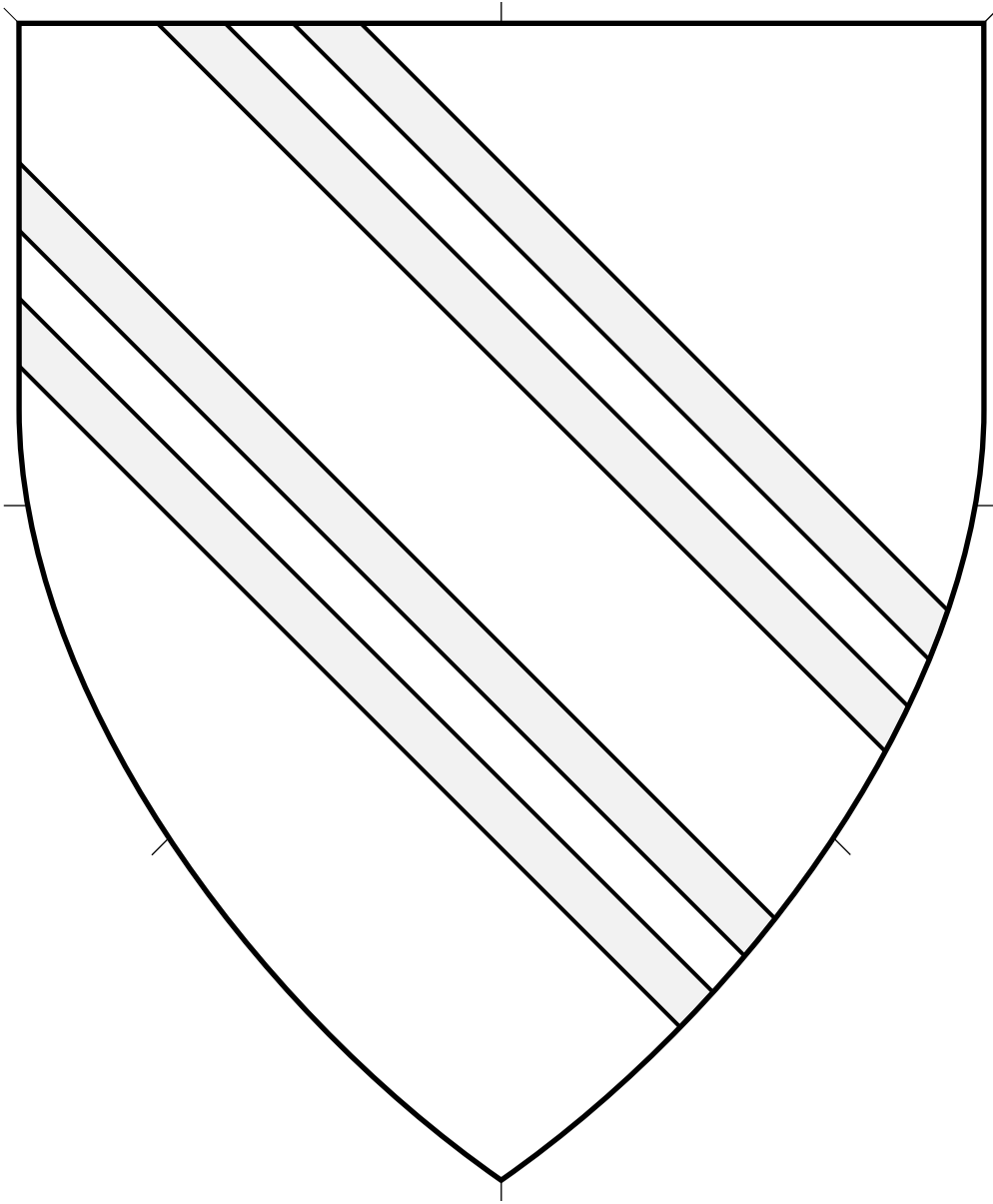

Central ordinary.

Source: Insignia Anglica. Artist unknown.

Bendlets Gemel, Two (2) 4.131

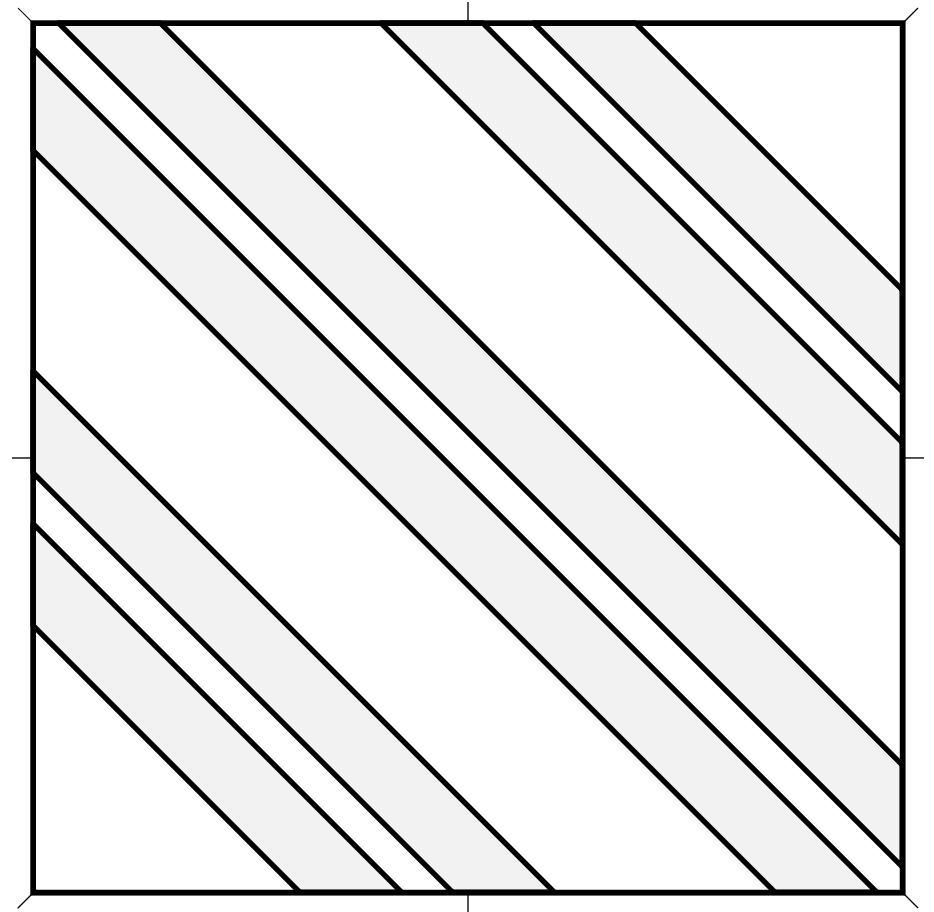
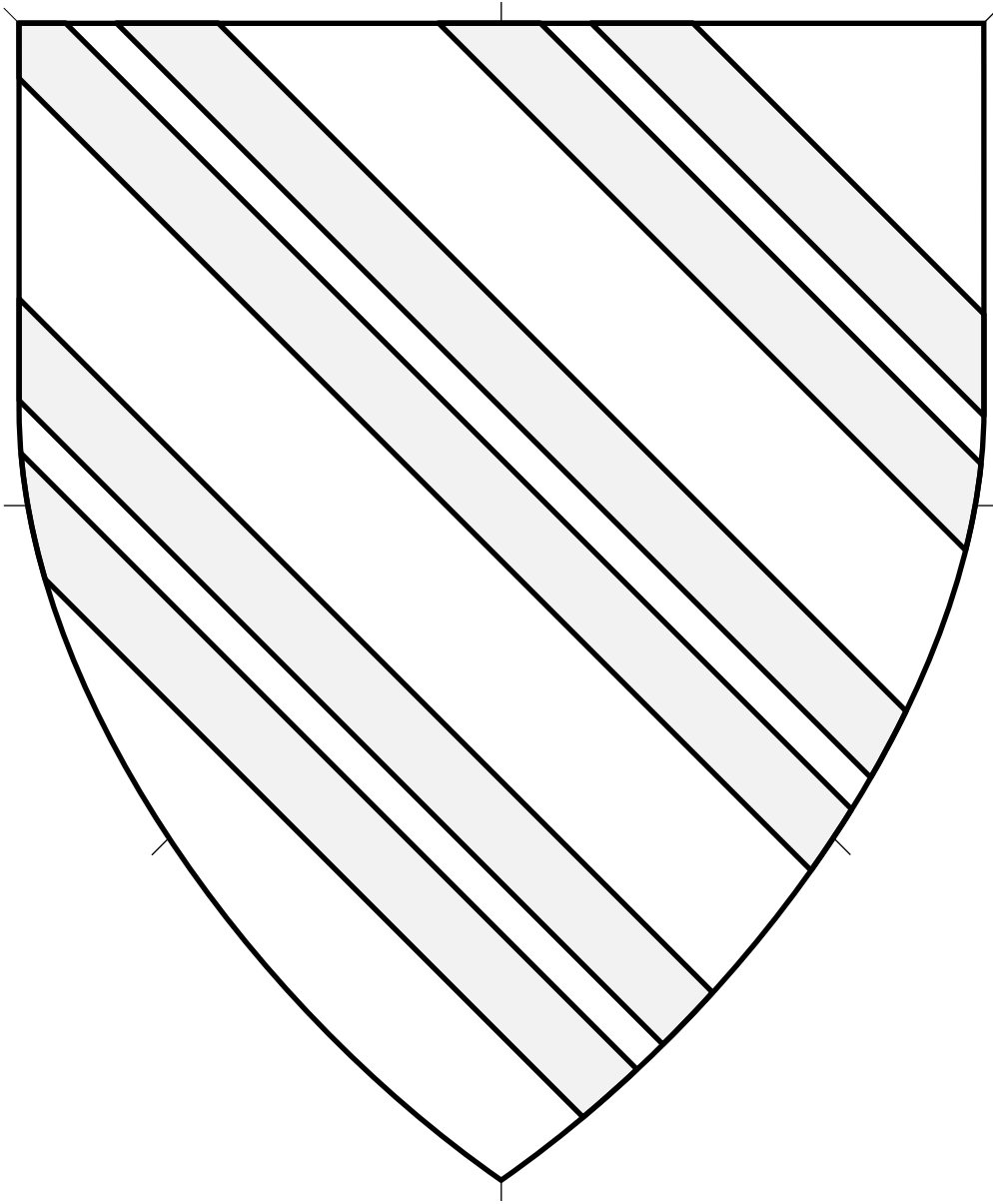

Central ordinary.

Source: Nobiliario de Armas de Valencia, Aragón y Cataluña.
Artist unknown. (Folio 69v.)

Bendlets Gemel, Three 4.132

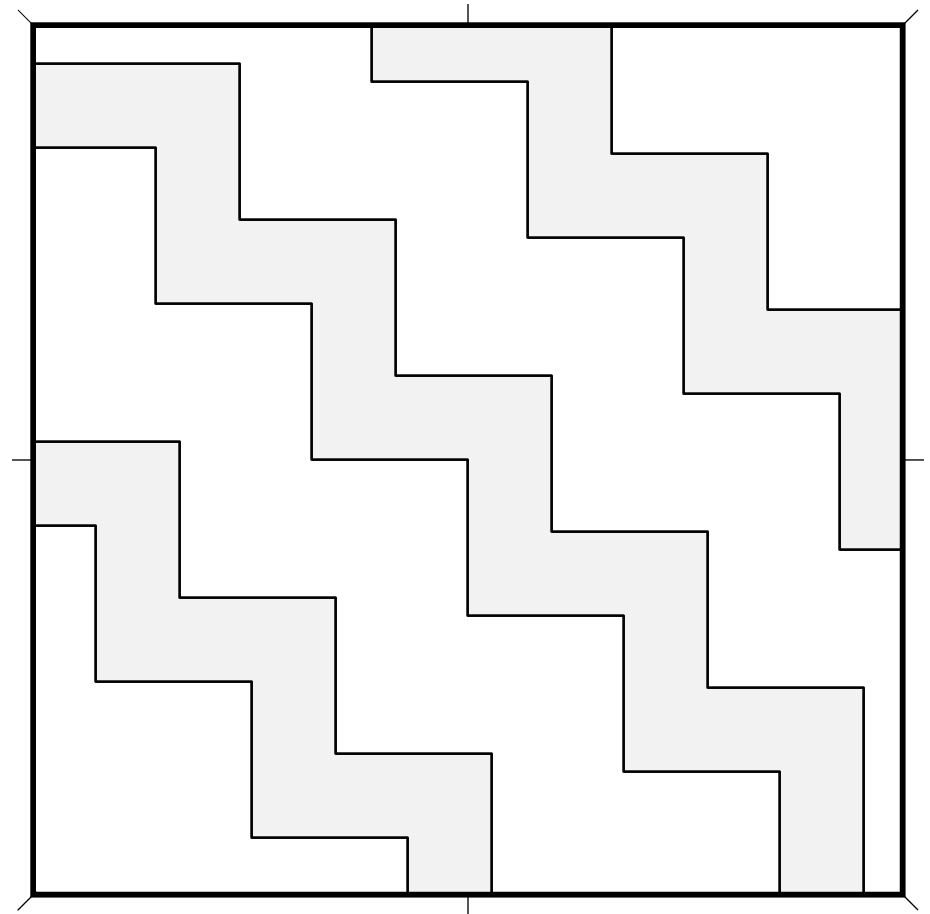
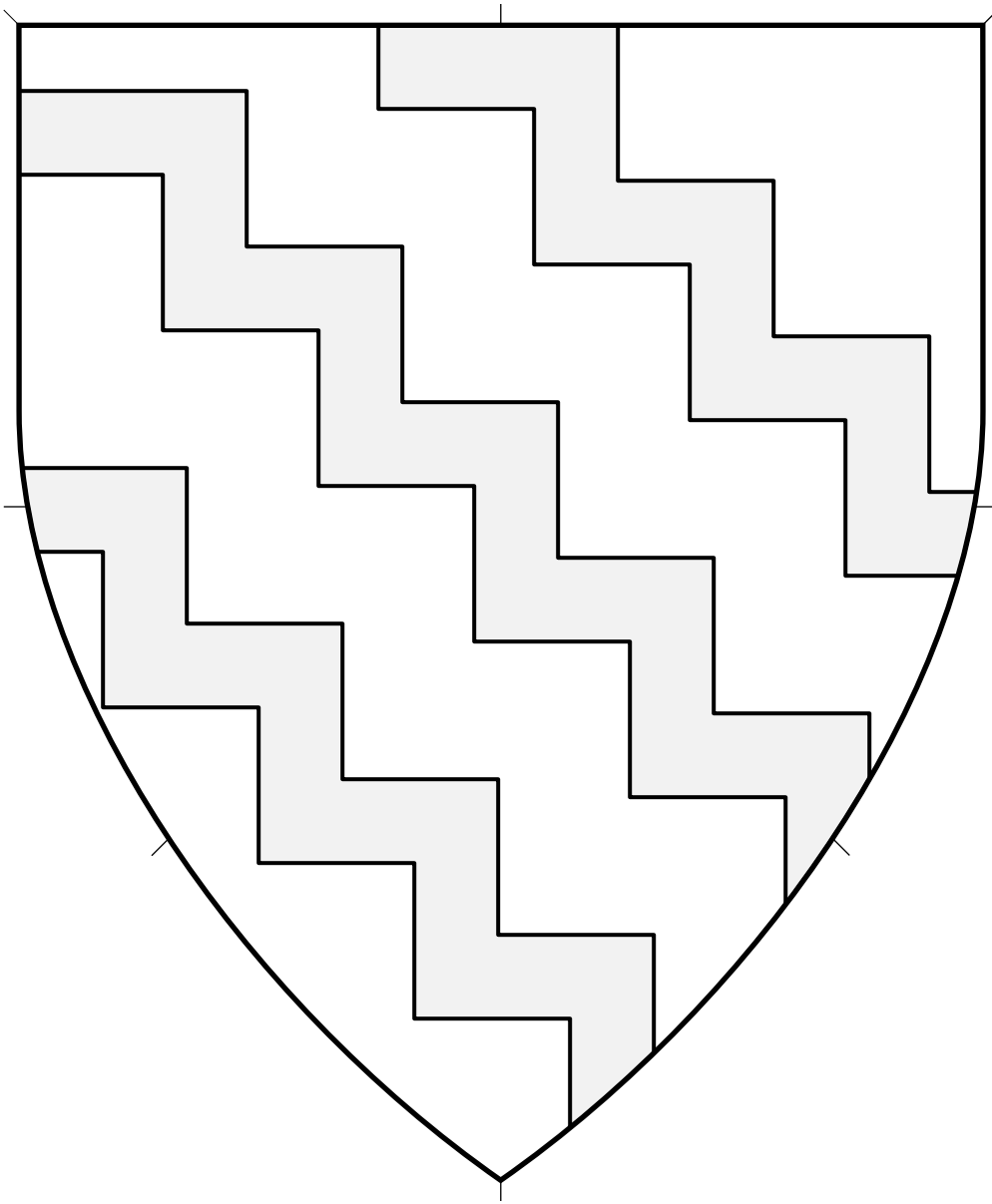

Central ordinary.

Source: Araldo Nel Quale si Vedono Delineate e Colorite le Armi de' Potentati e Sovrani d'Europa. Artist unknown. (Page 49.)

Bendlets Indented, 3 4.133

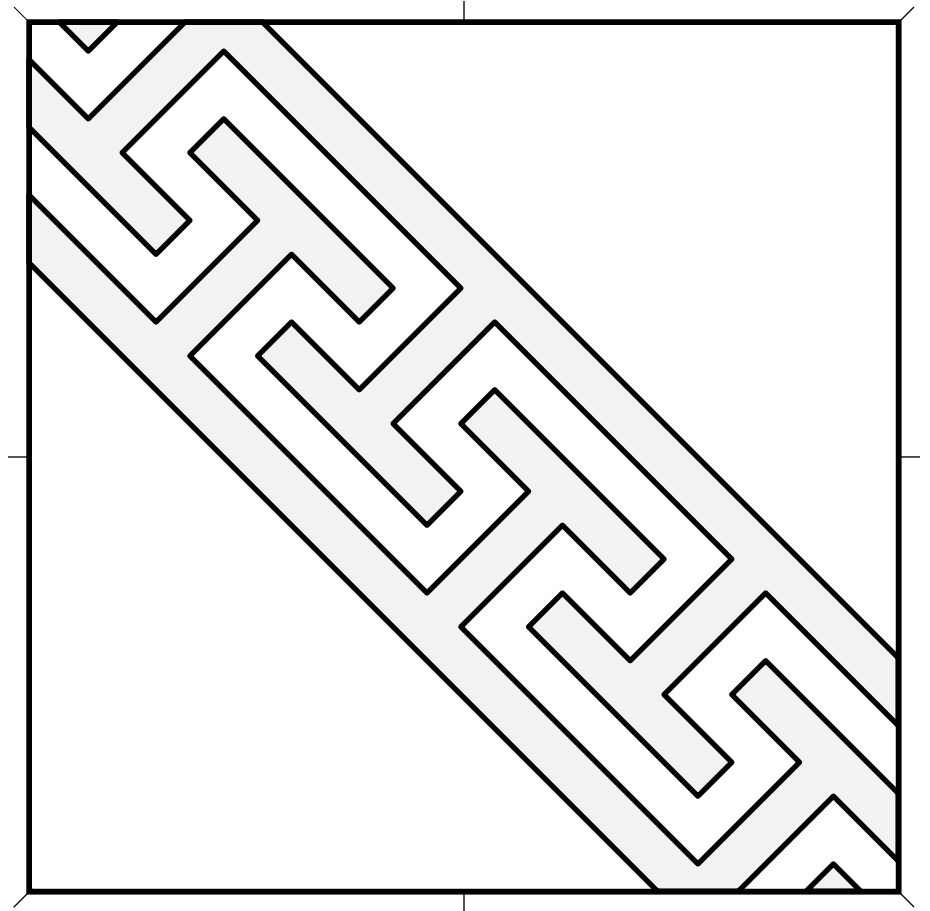
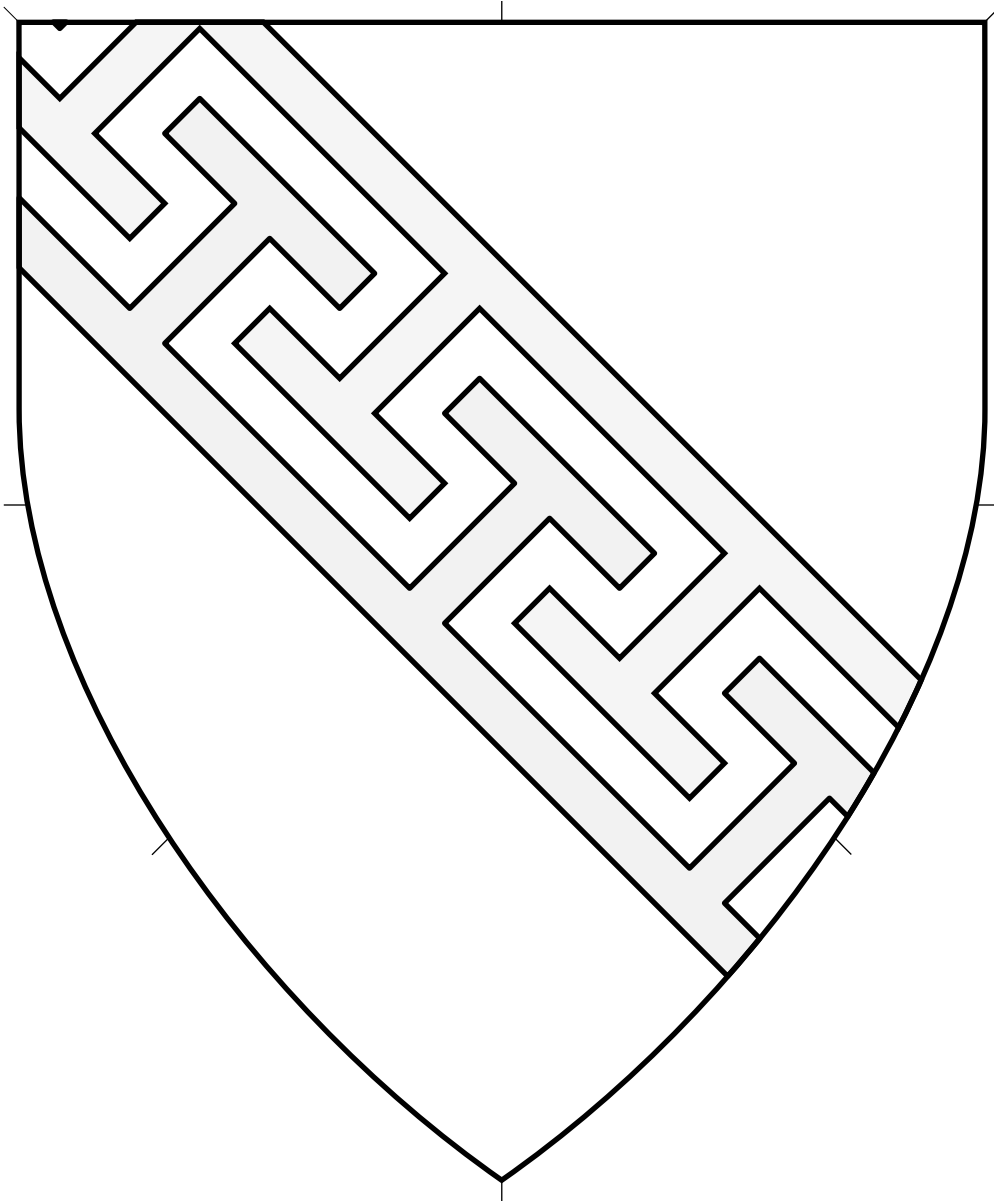

Central ordinary.

Source: Universeel Wapenboek. Artist unknown. (Folio 4v.)

Bendlets Interiors Potent Counter-potent, 2 4.134

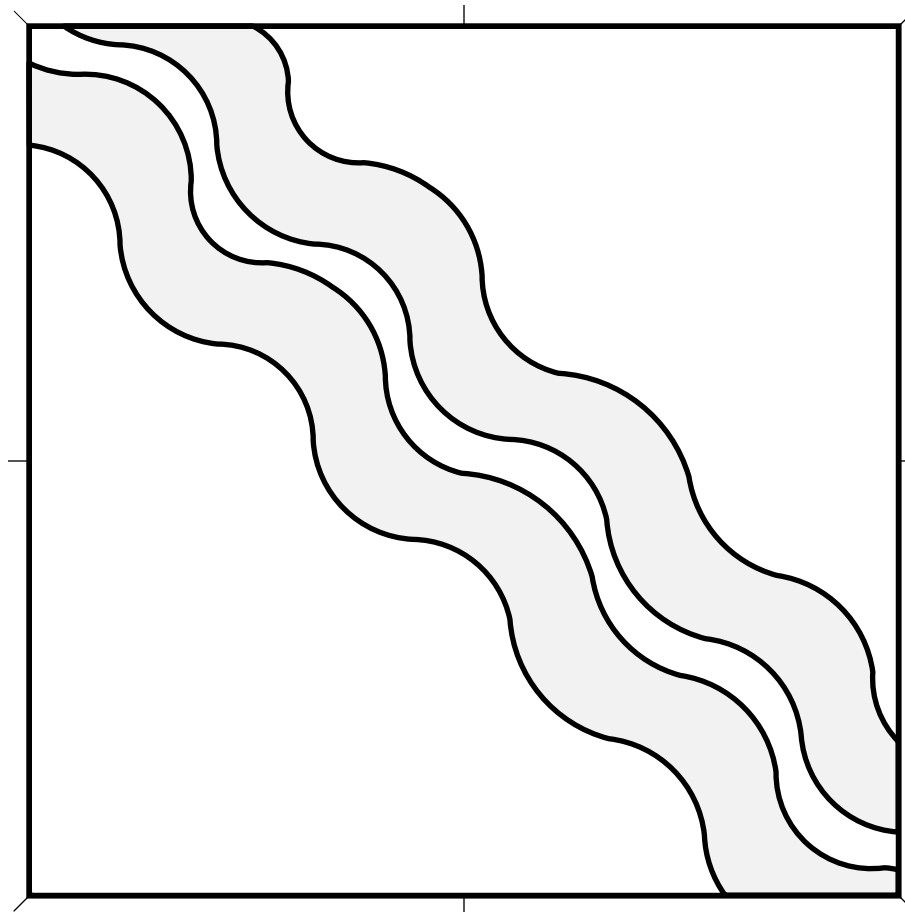
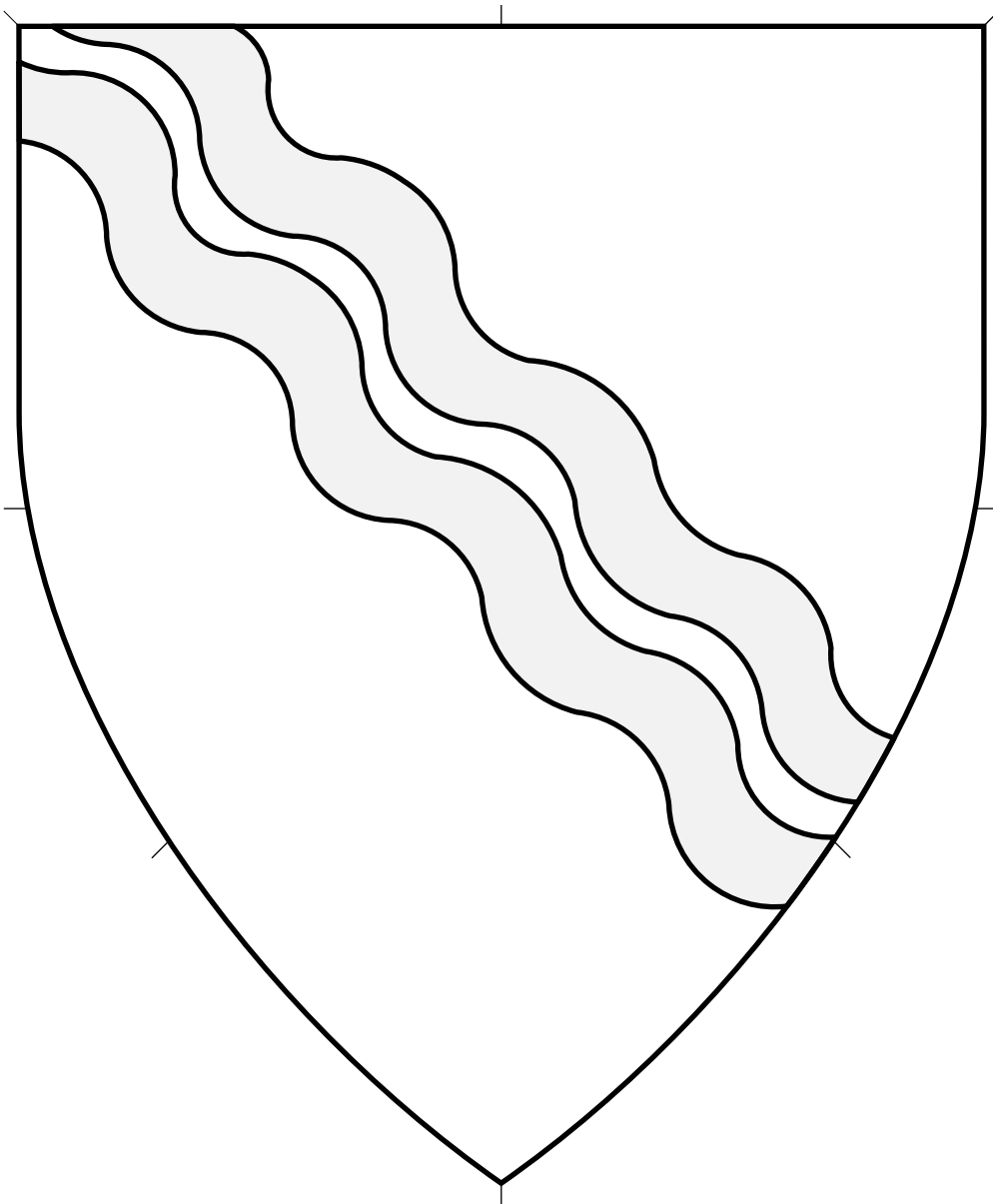

Central ordinary.

Source: Viking Answer Lady SVG Images For Heraldry.
Artist: Gunnvôr silfrahárr. Adapted by Mathghamhain Ua Ruadháin.

Bendlets Wavy, 2 4.135

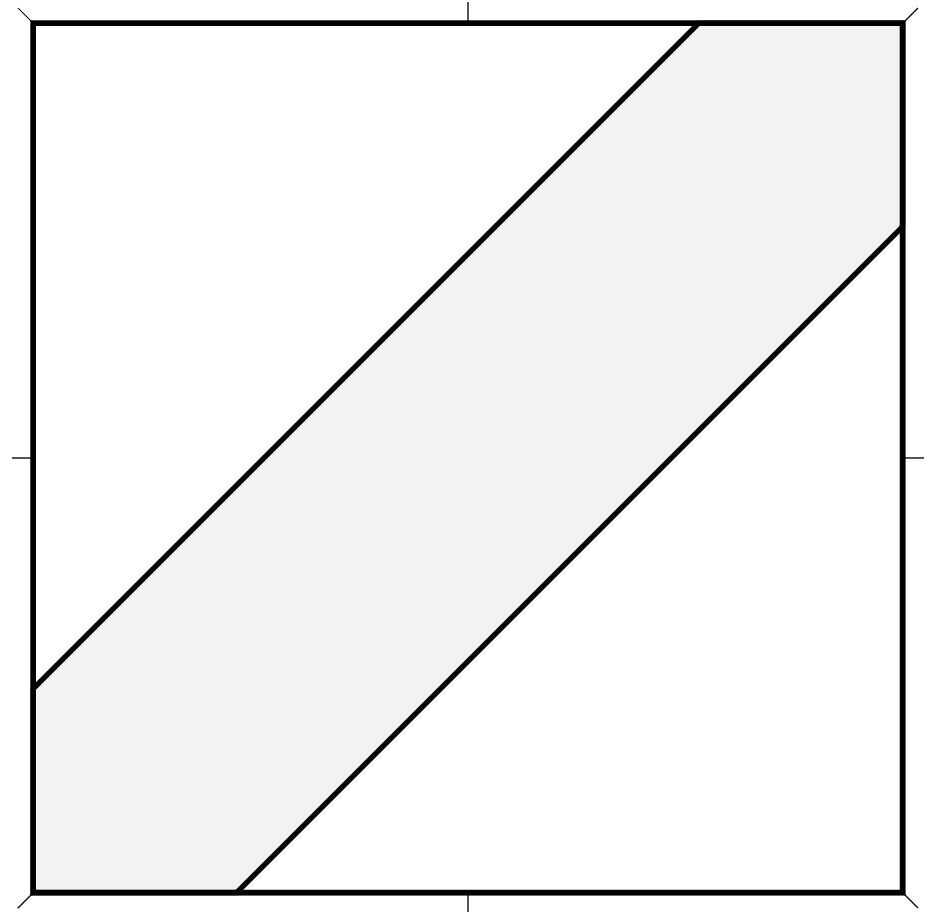
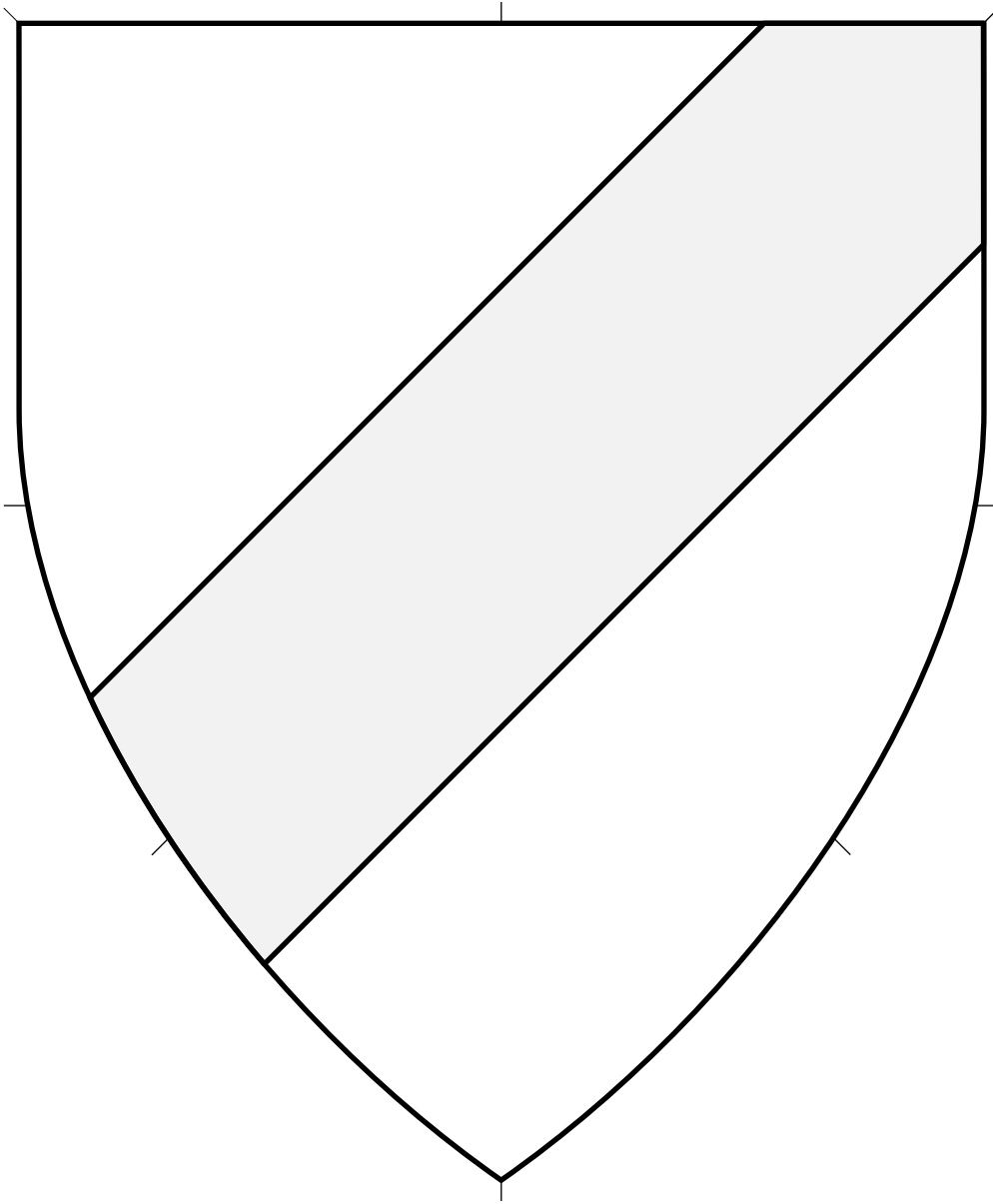

Central ordinary. The width may be a third of the width of the device or a bit narrower.

This is a wider bend, suitable for bearing a charge.

Bend Sinister (1) 4.136

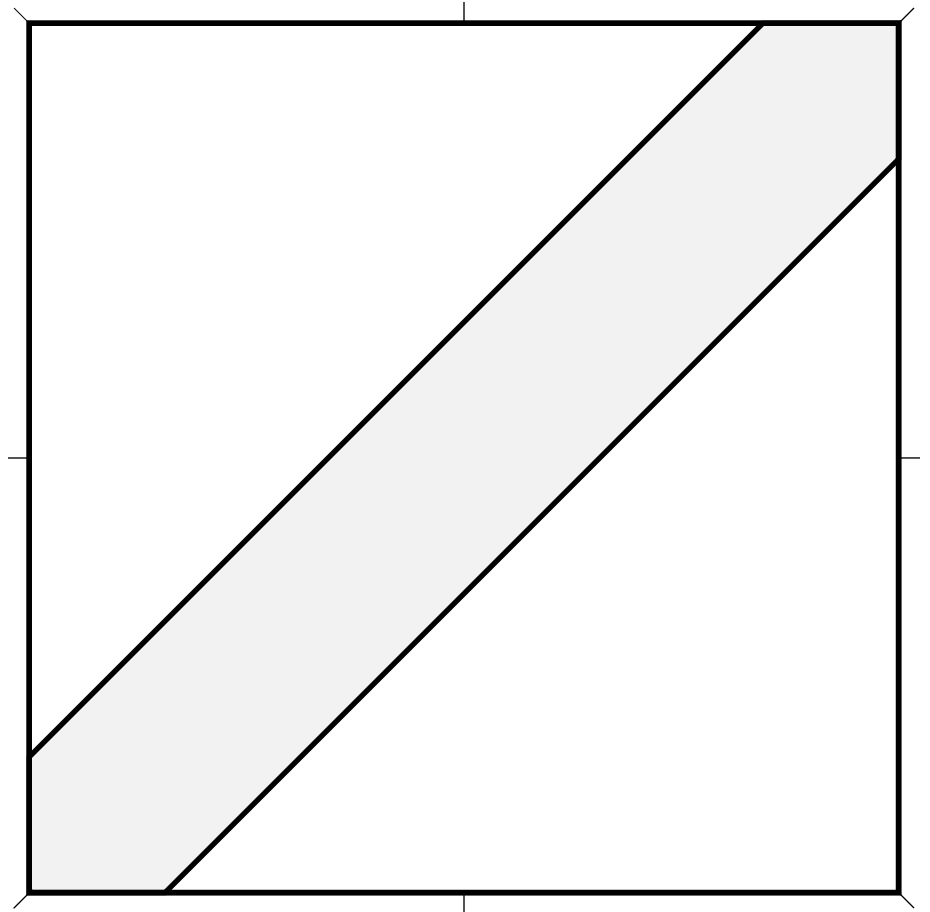
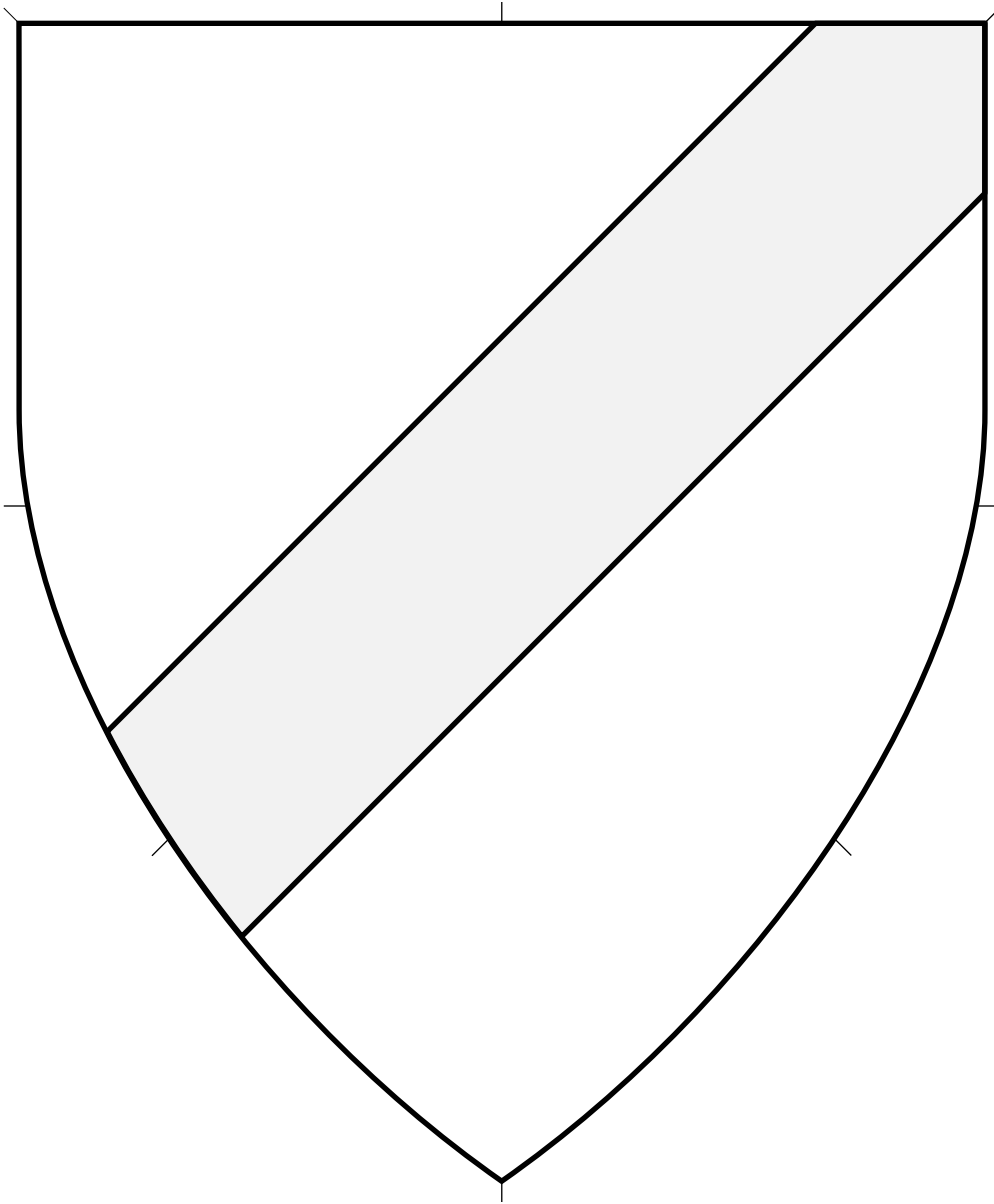

Central ordinary. The width may be a third of the width of the device or a bit narrower.

This is a thinner bend.

Bend Sinister (2) 4.137

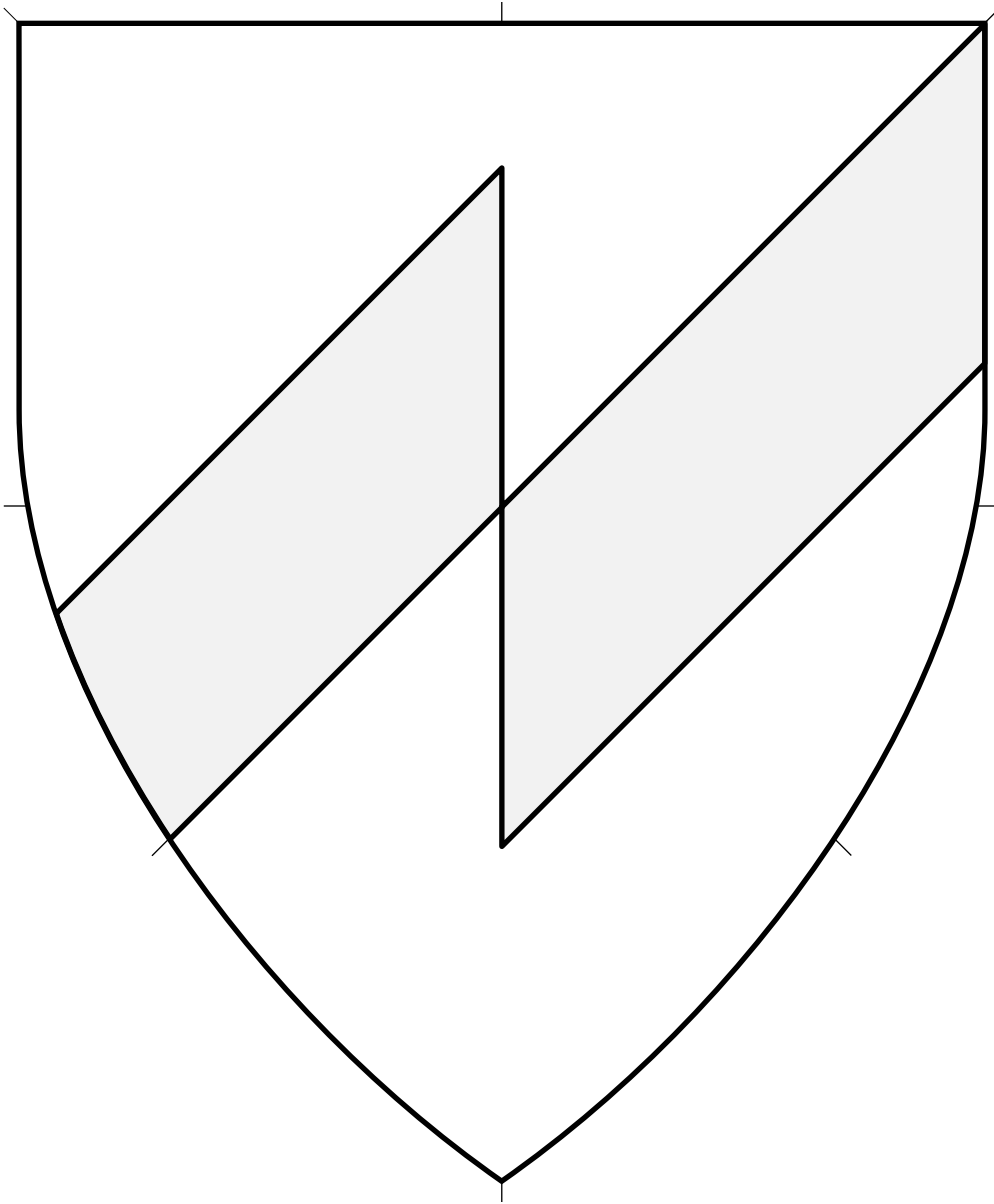

Central ordinary.

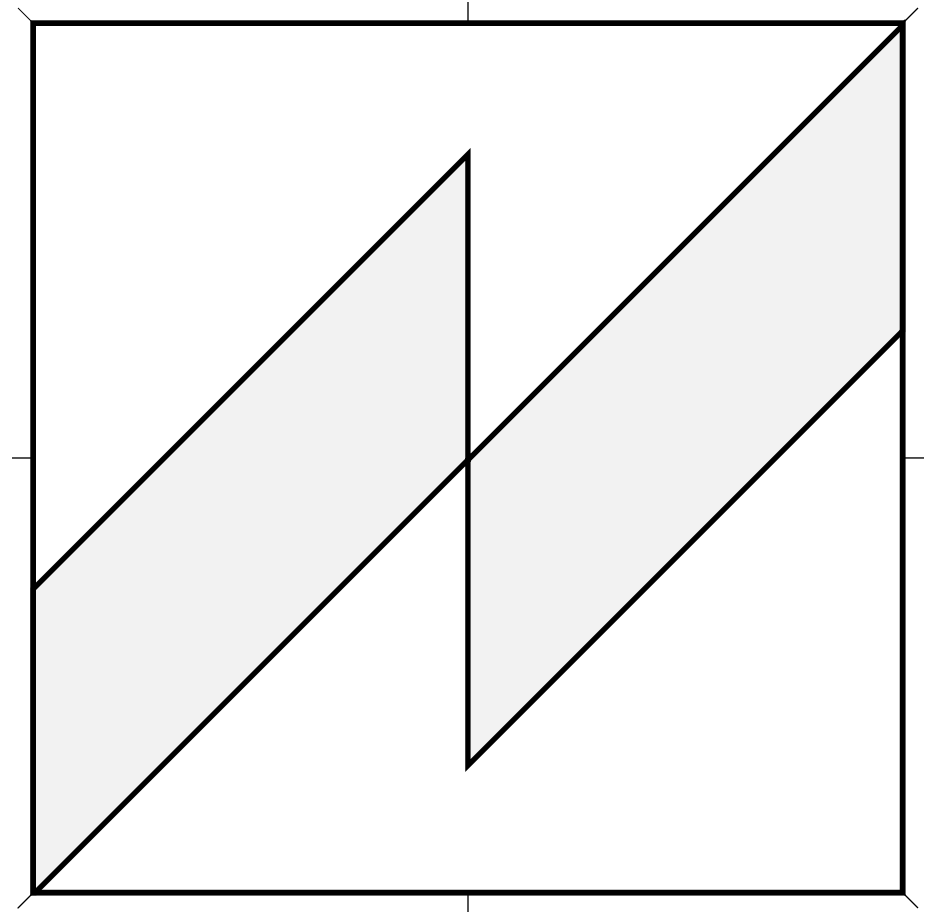

Bend Sinister Bevilled 4.138

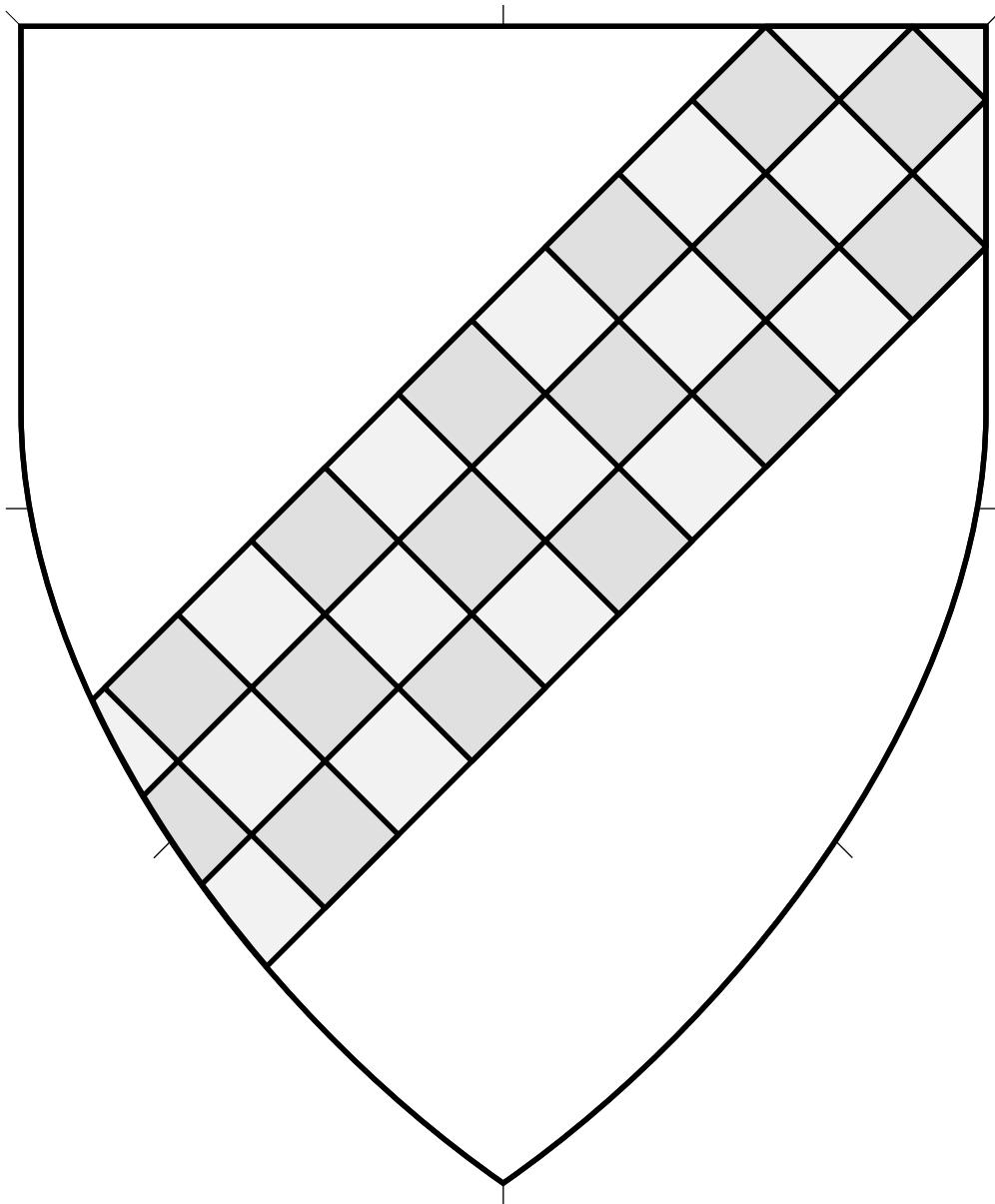

Central ordinary. Two contrasting tinctures.

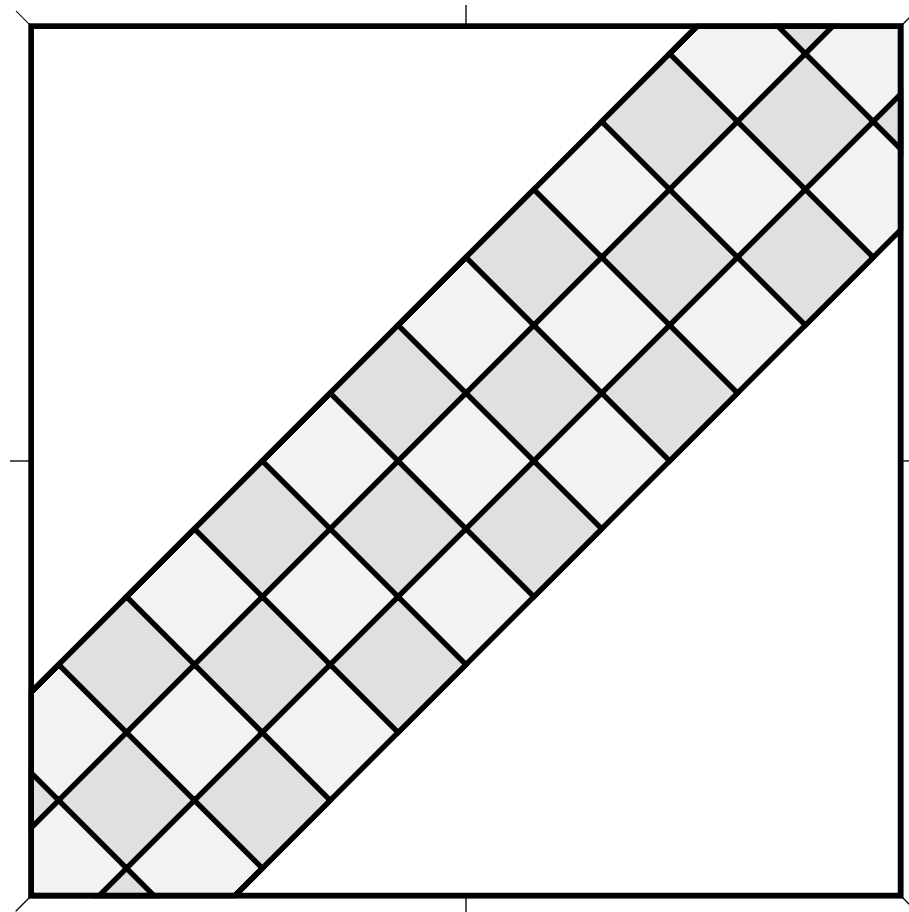

Bend Sinister Checky 4.139

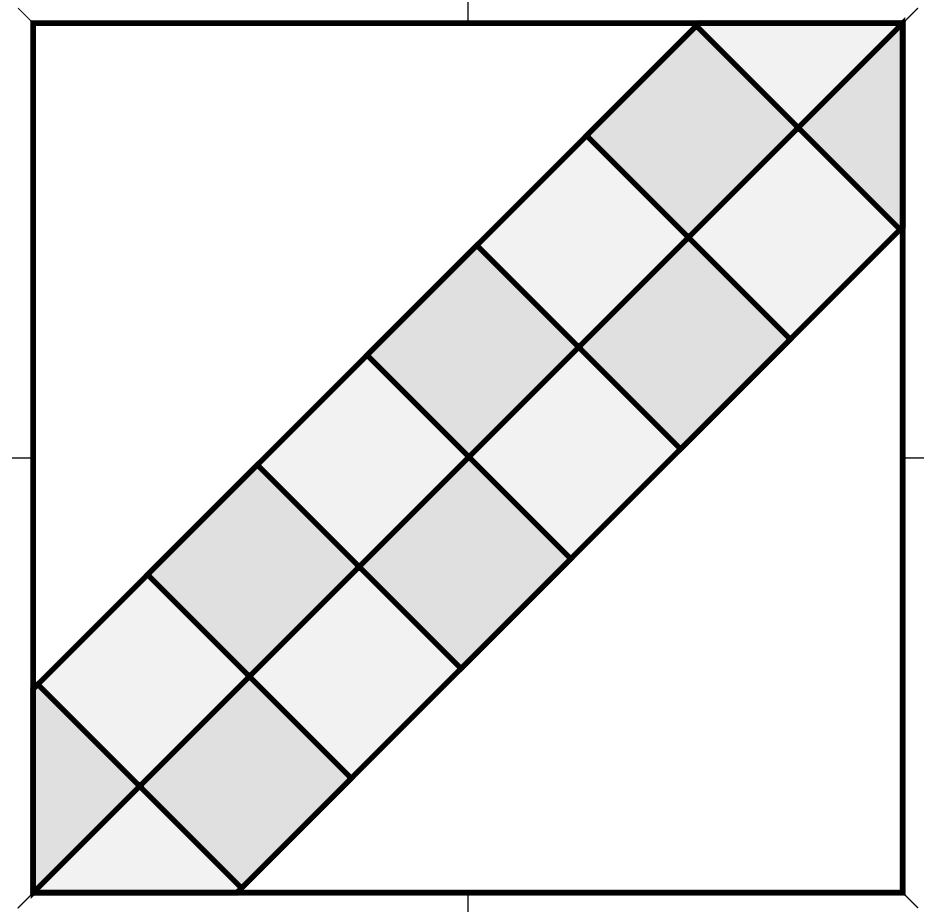
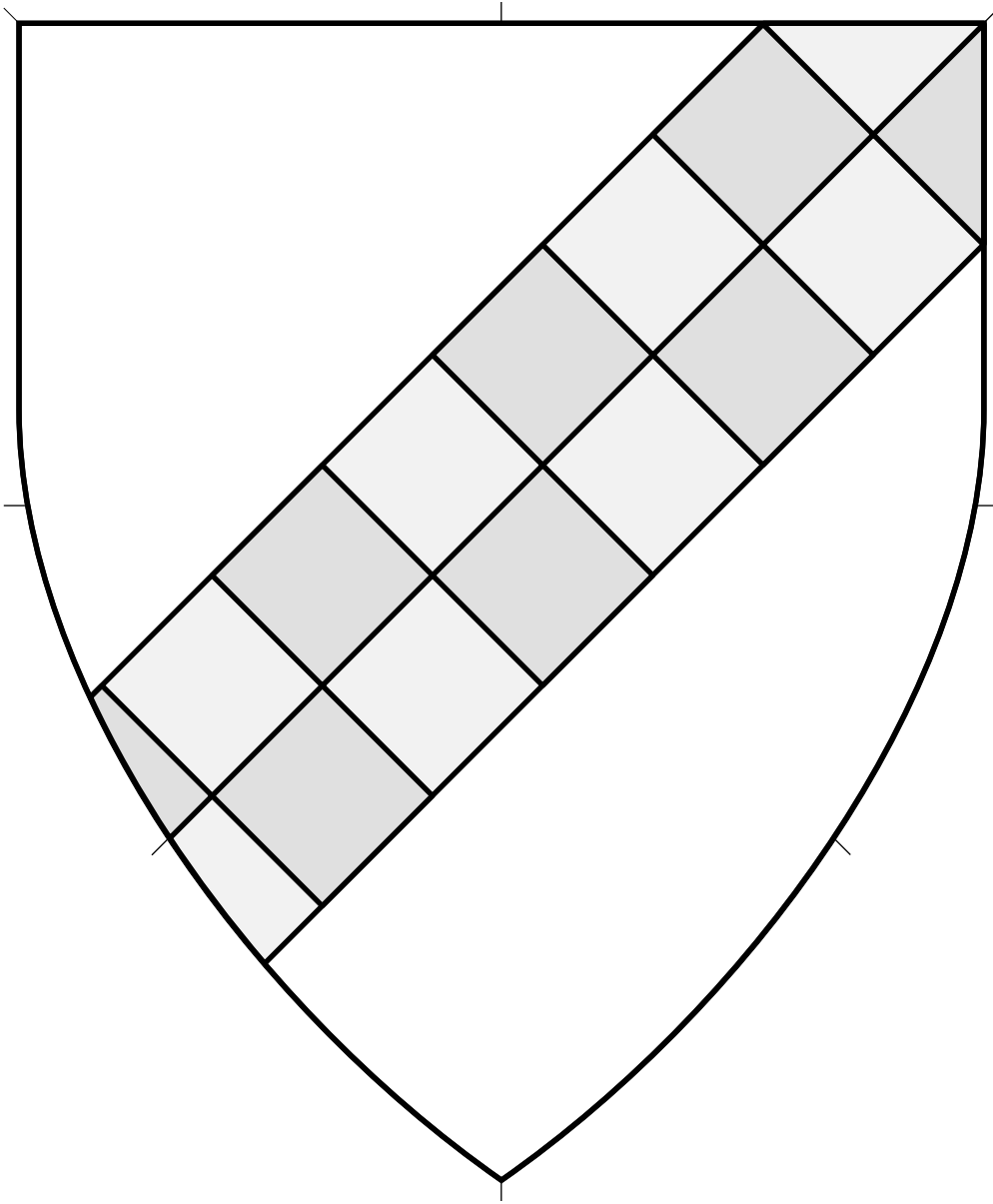

Central ordinary. Two contrasting tinctures.

Bend Sinister Counter-compony 4.140

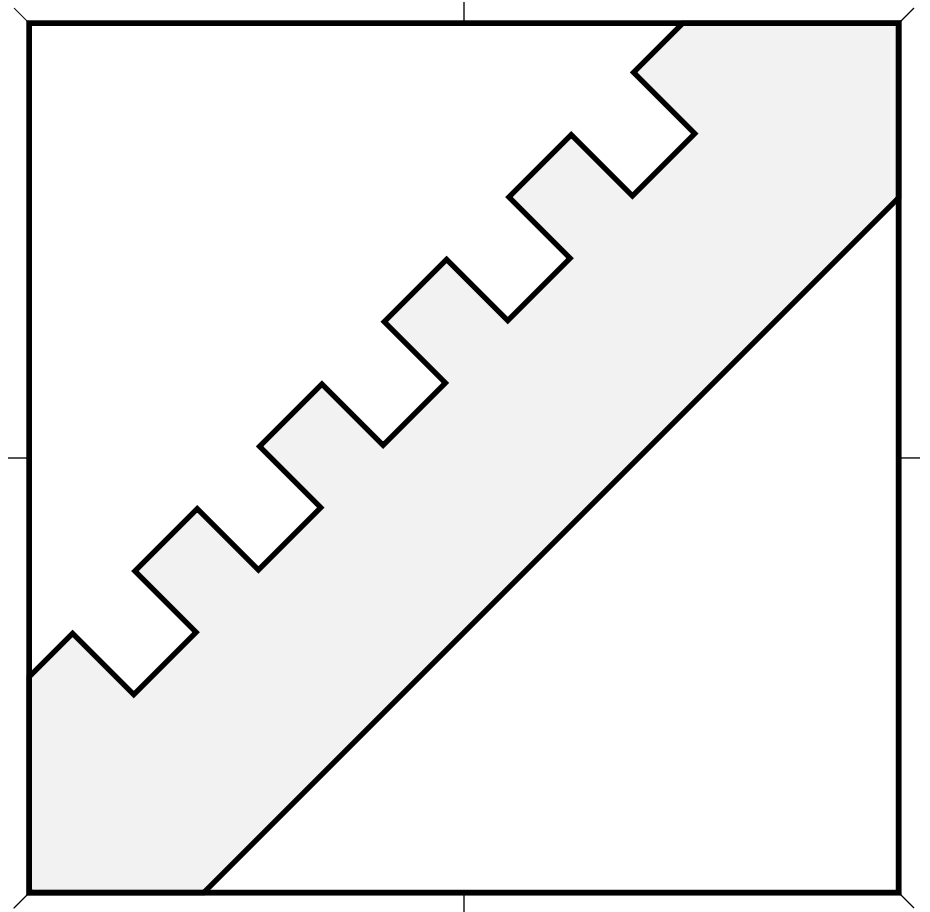
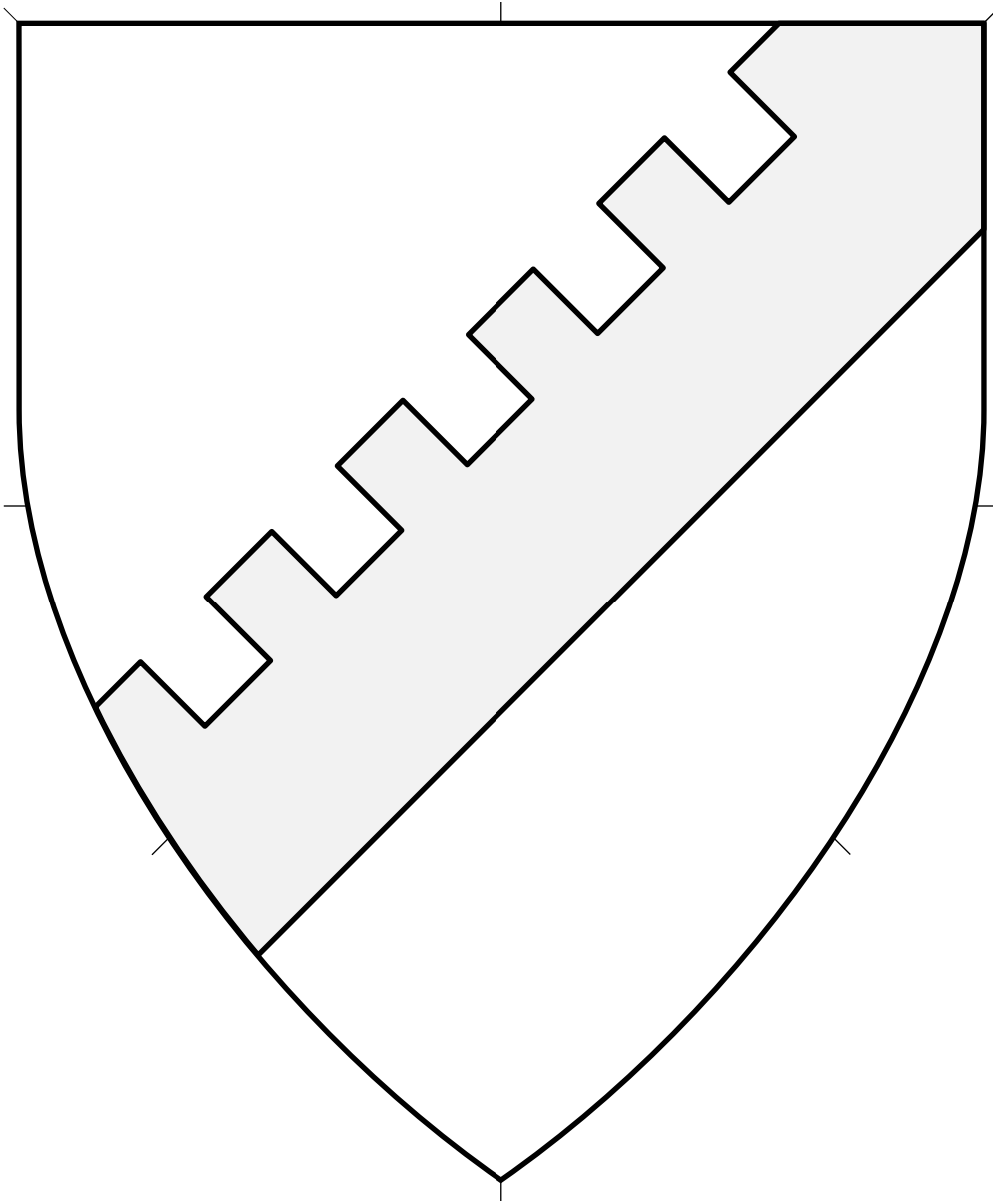

Central ordinary.

Bend Sinister Embattled 4.141

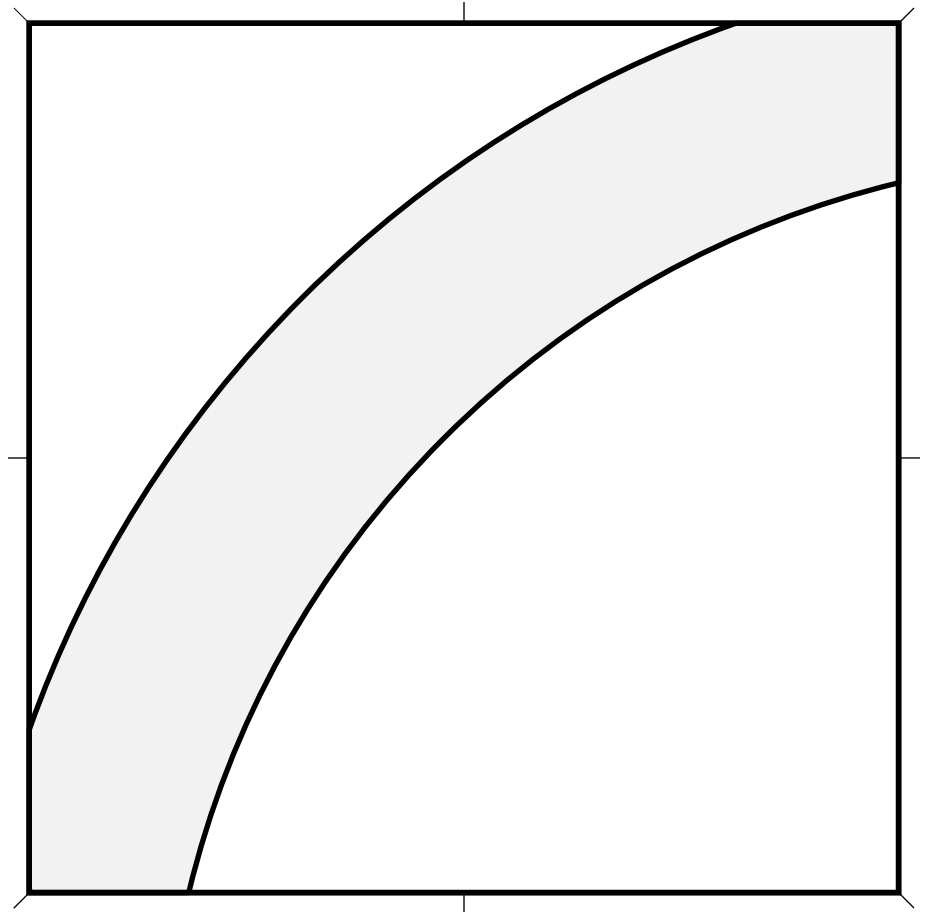
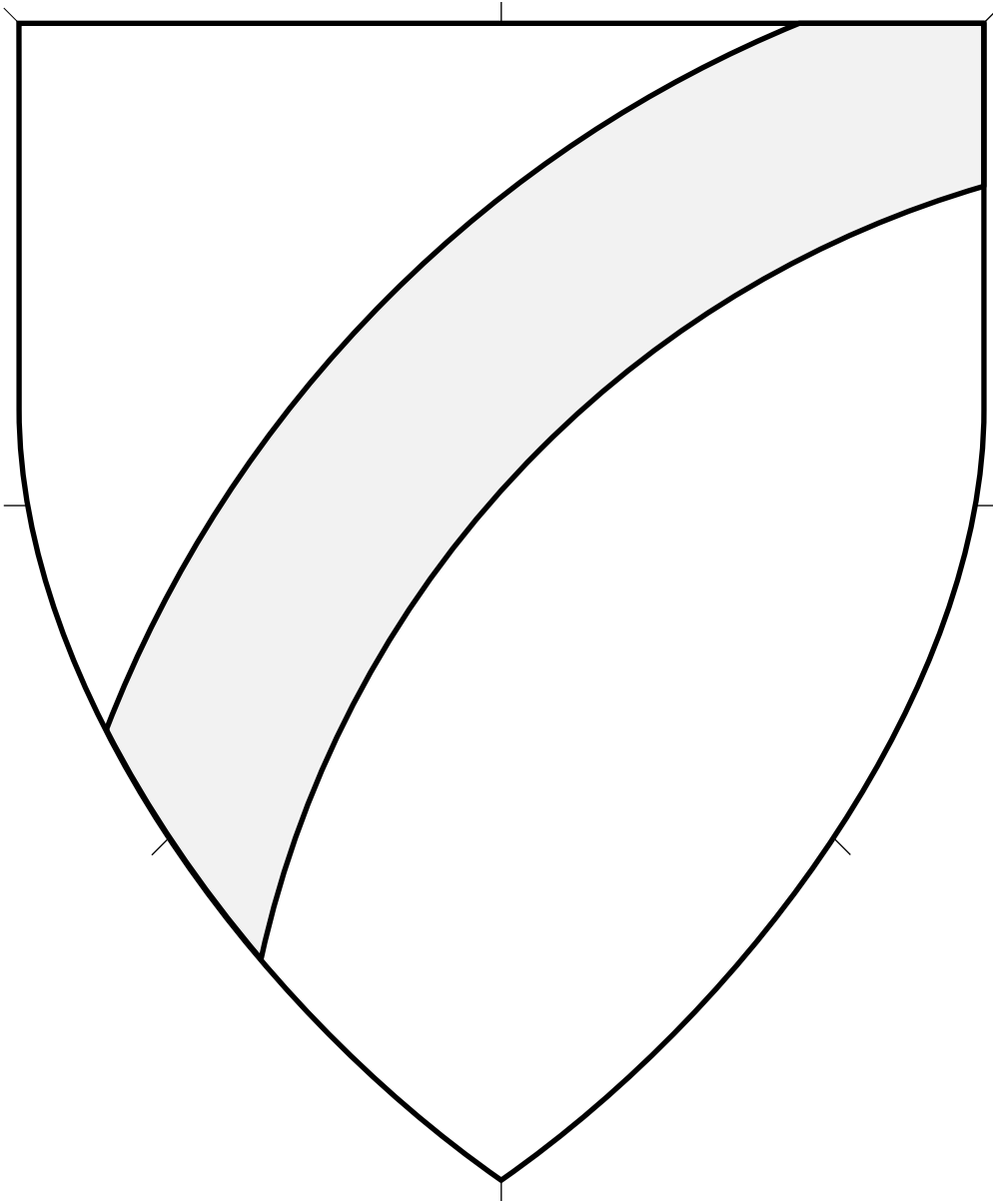

Central ordinary. A bend embowed to chief.

Bend Sinister Enarched 4.142

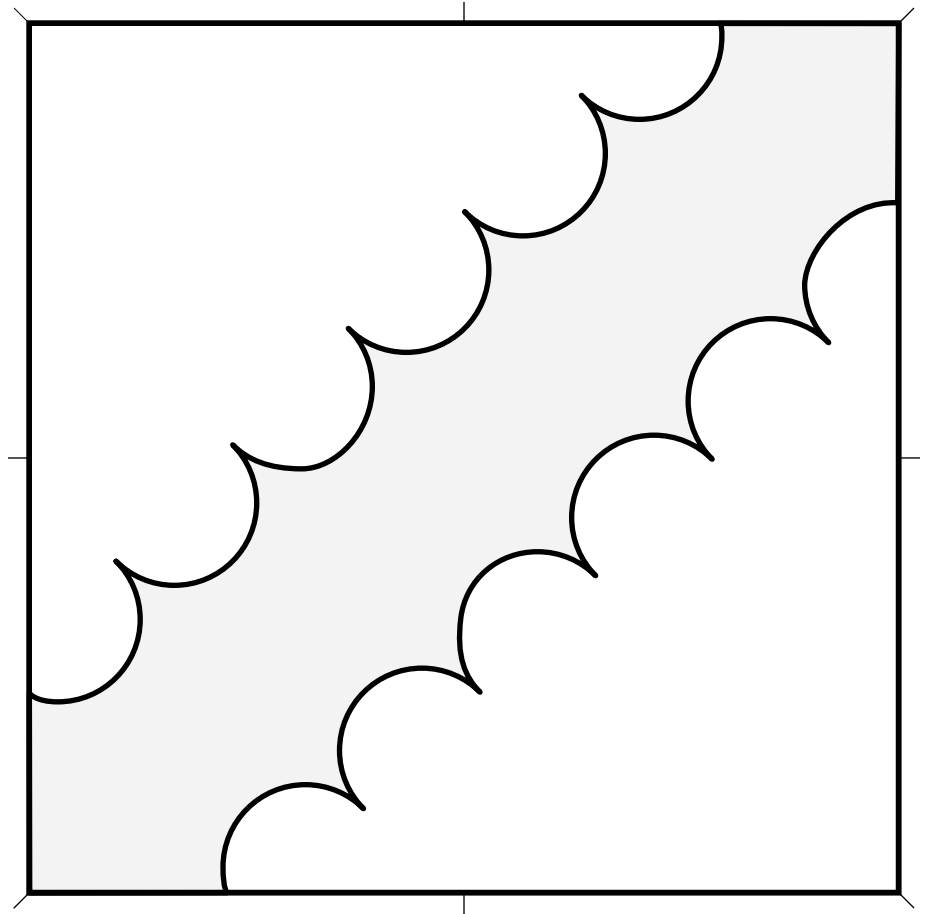
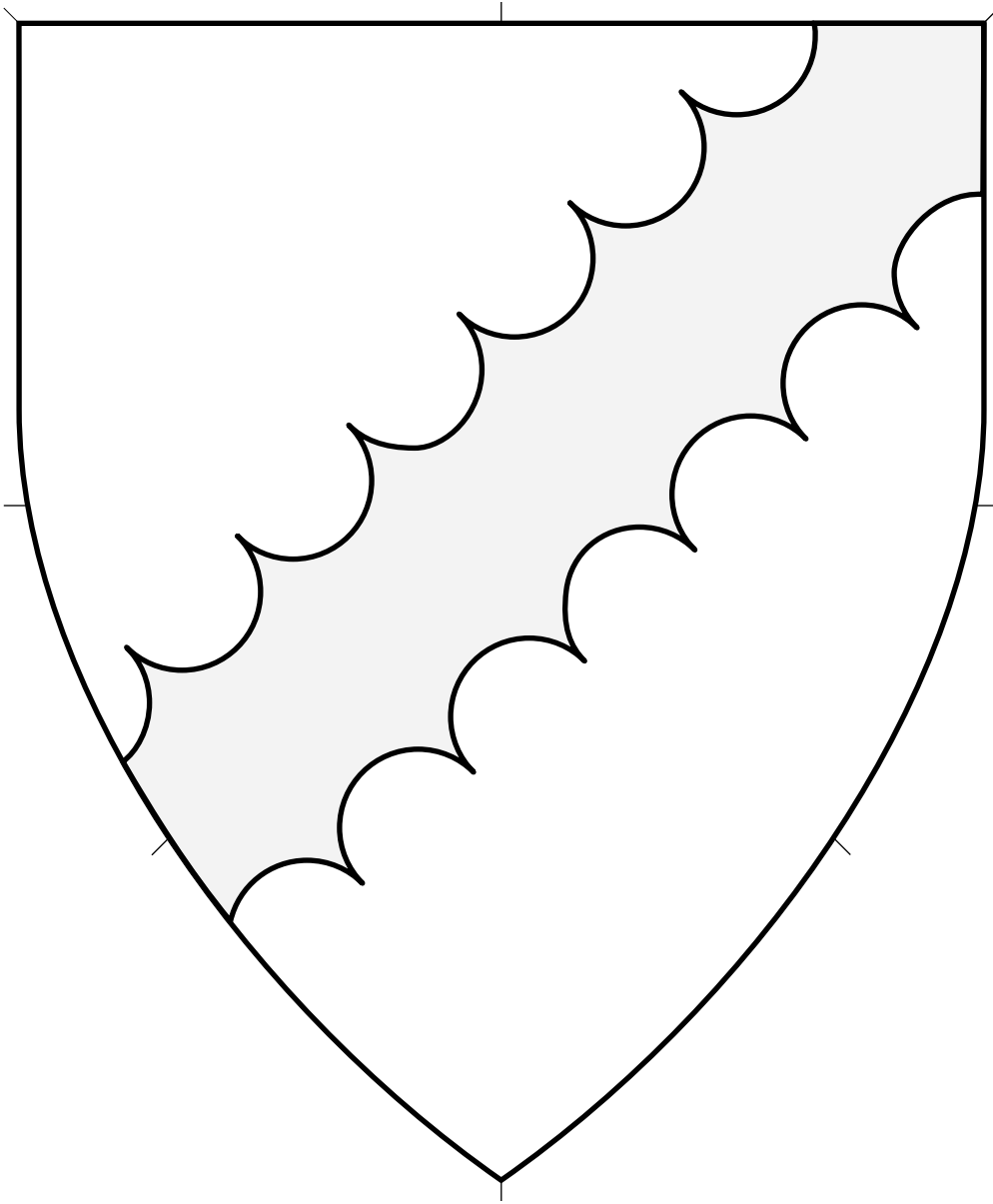

Central ordinary.

Artist: Elionora inghean Ui Cheallaigh.
Adapted by Mathghamhain Ua Ruadháin.

Bend Sinister Engrailed 4.143

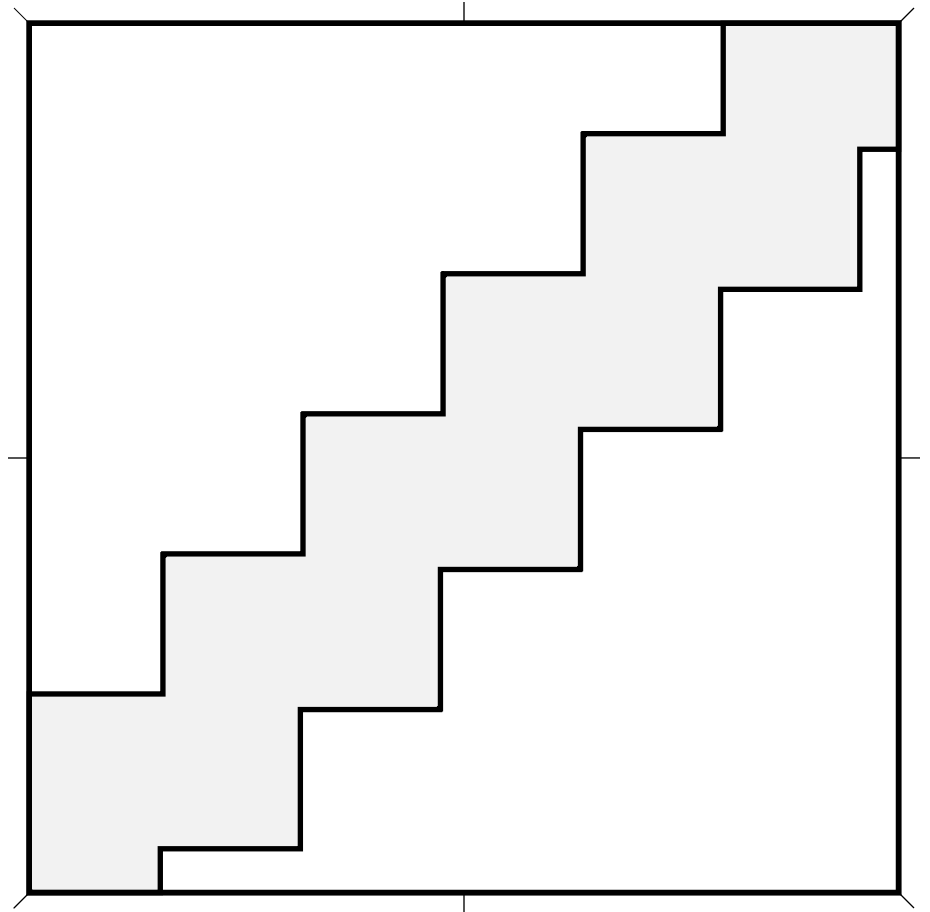
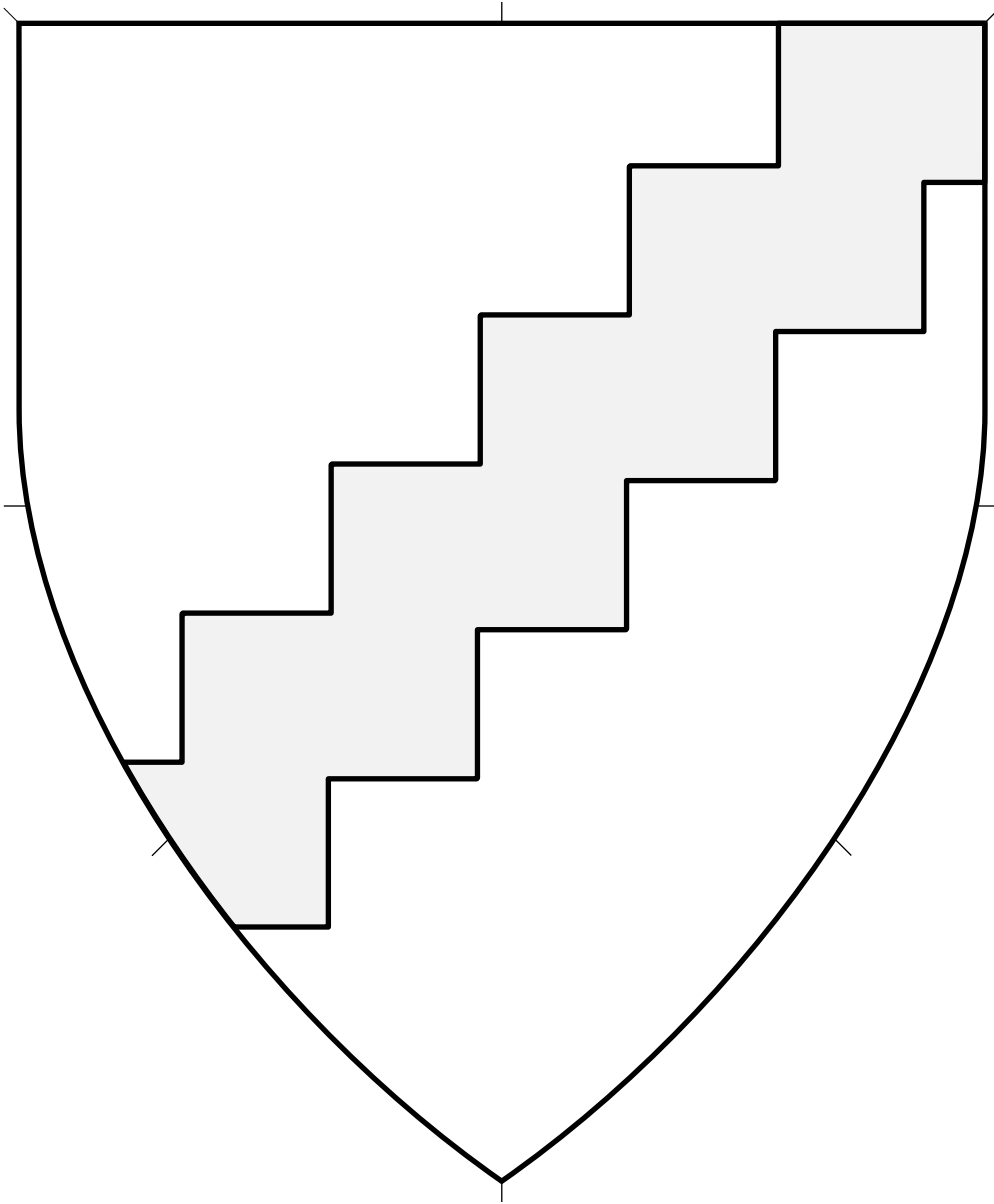

Central ordinary.

Bend Sinister Indented 4.144

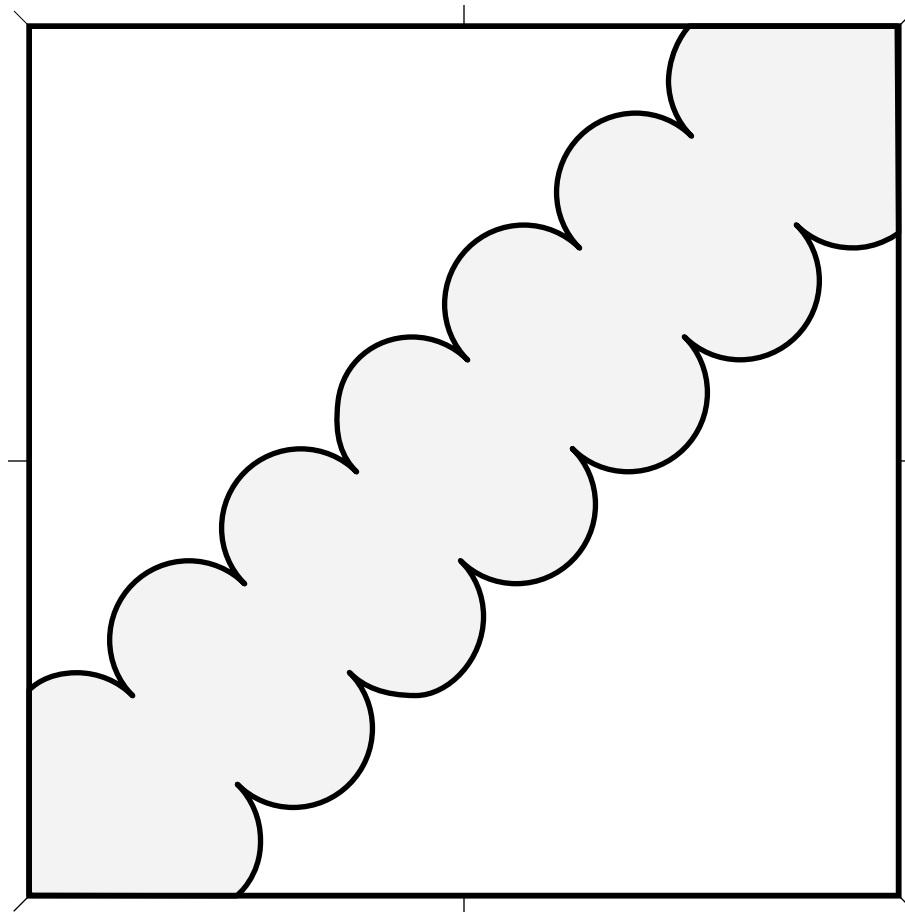
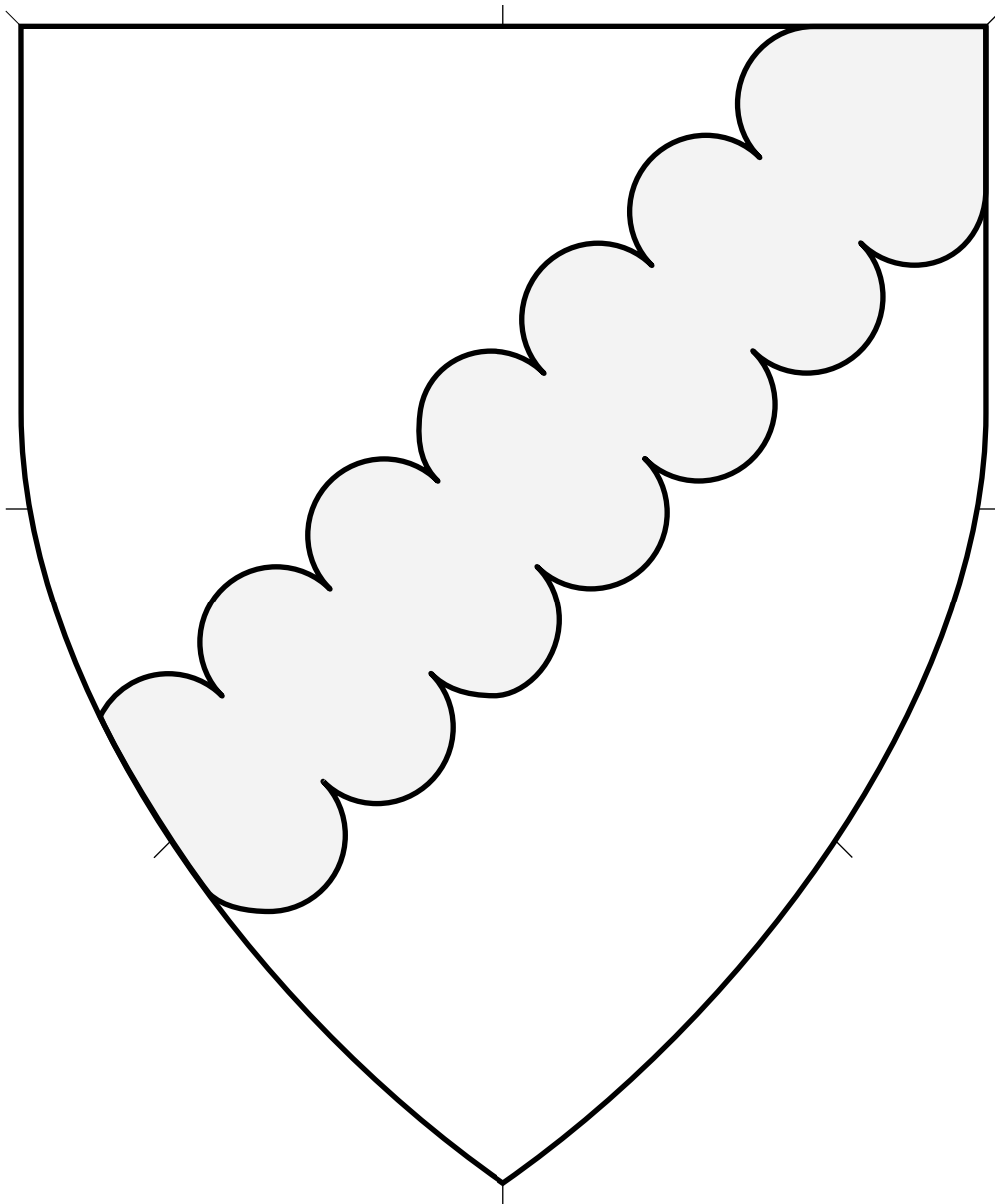

Central ordinary.

Artist: Elionora inghean Ui Cheallaigh.
Adapted by Mathghamhain Ua Ruadháin.

Bend Sinister Inverted 4.145

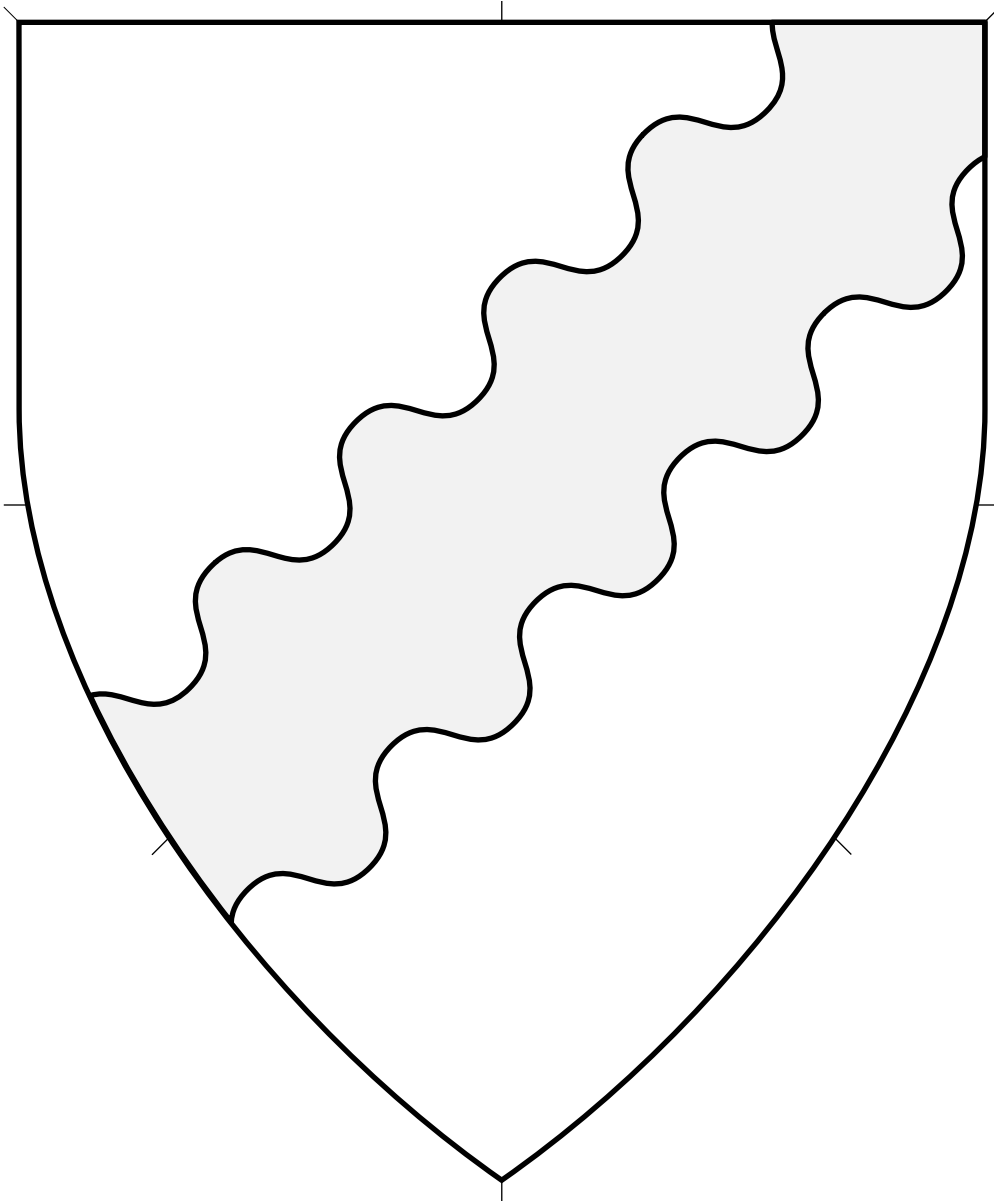

Central ordinary.

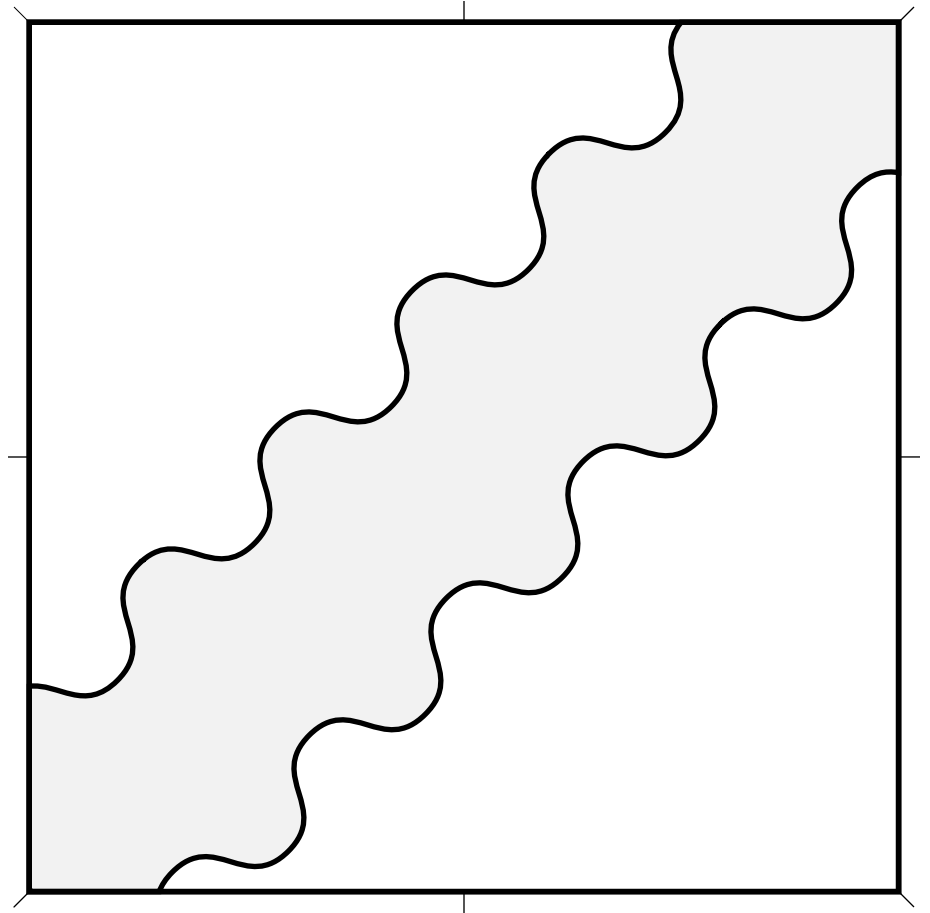

Bend Sinister Wavy 4.146

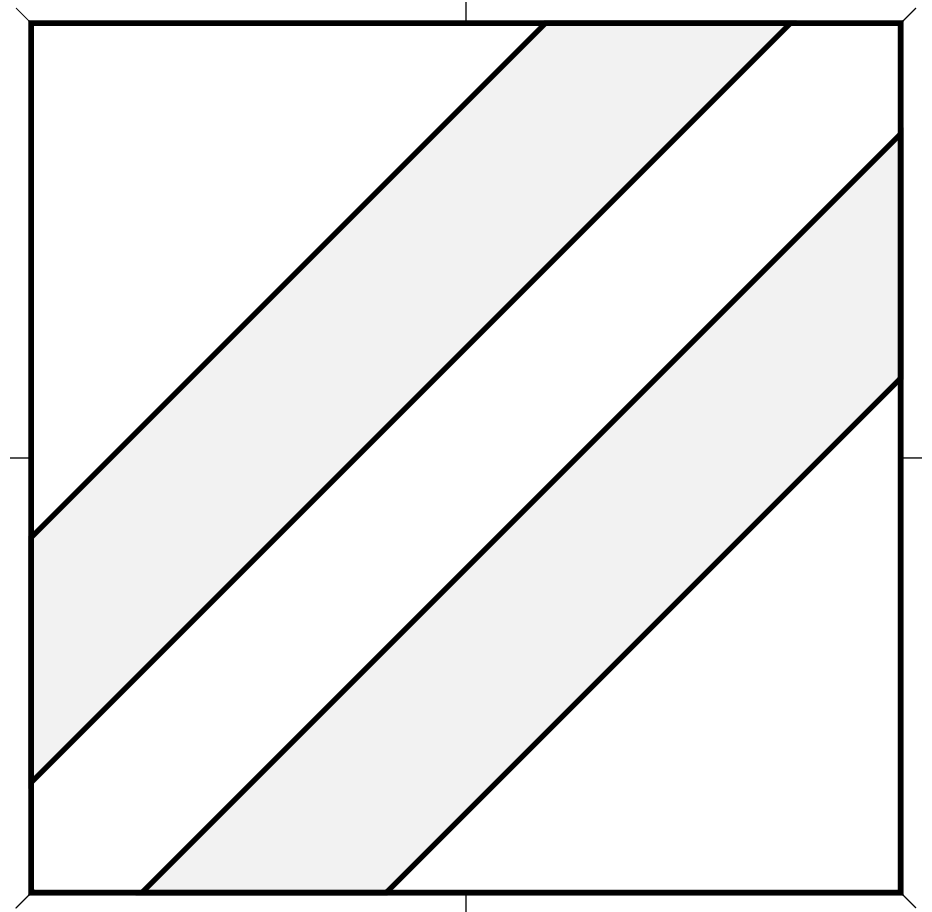
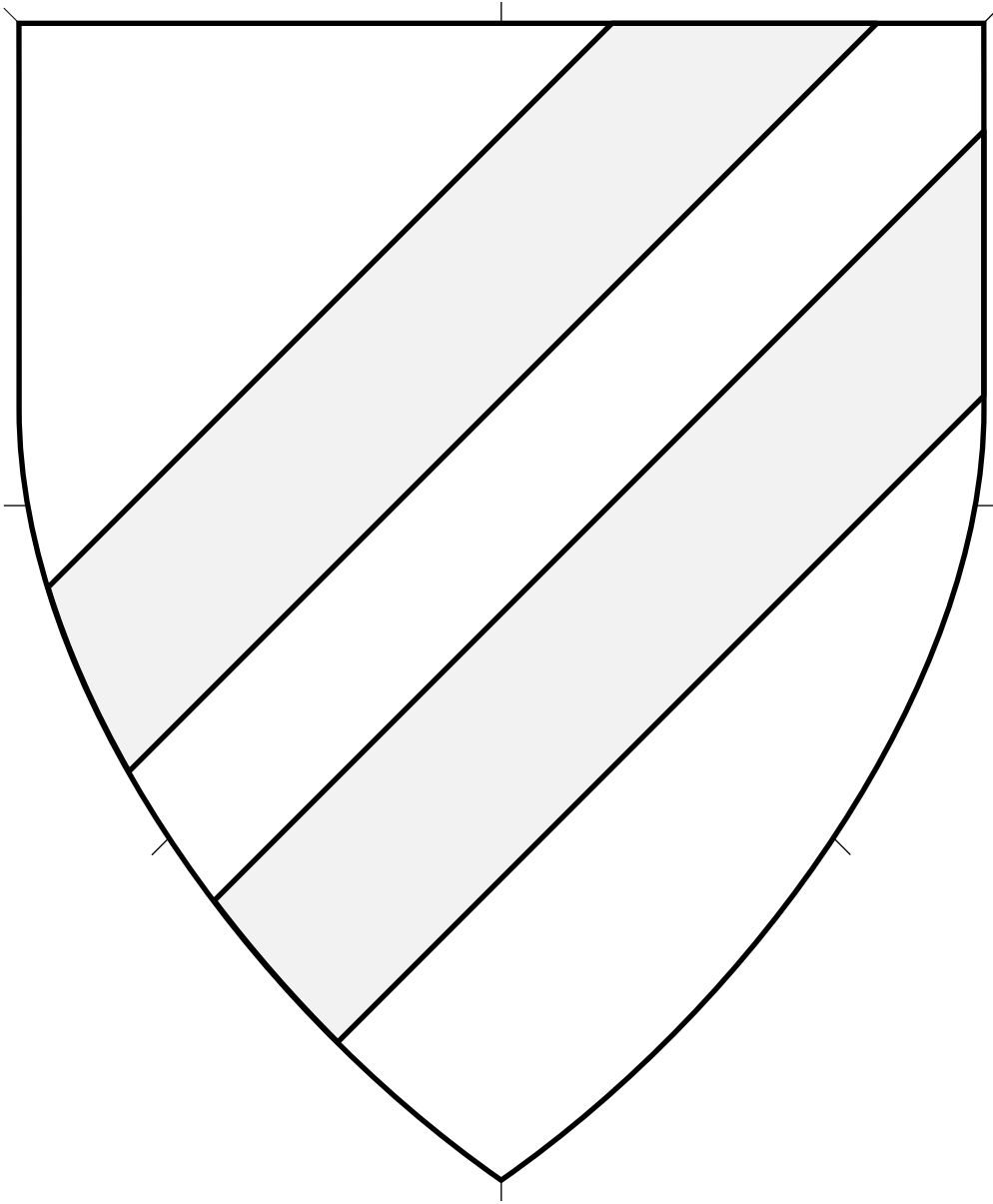

Central ordinary. Diminutive of the bend sinister.

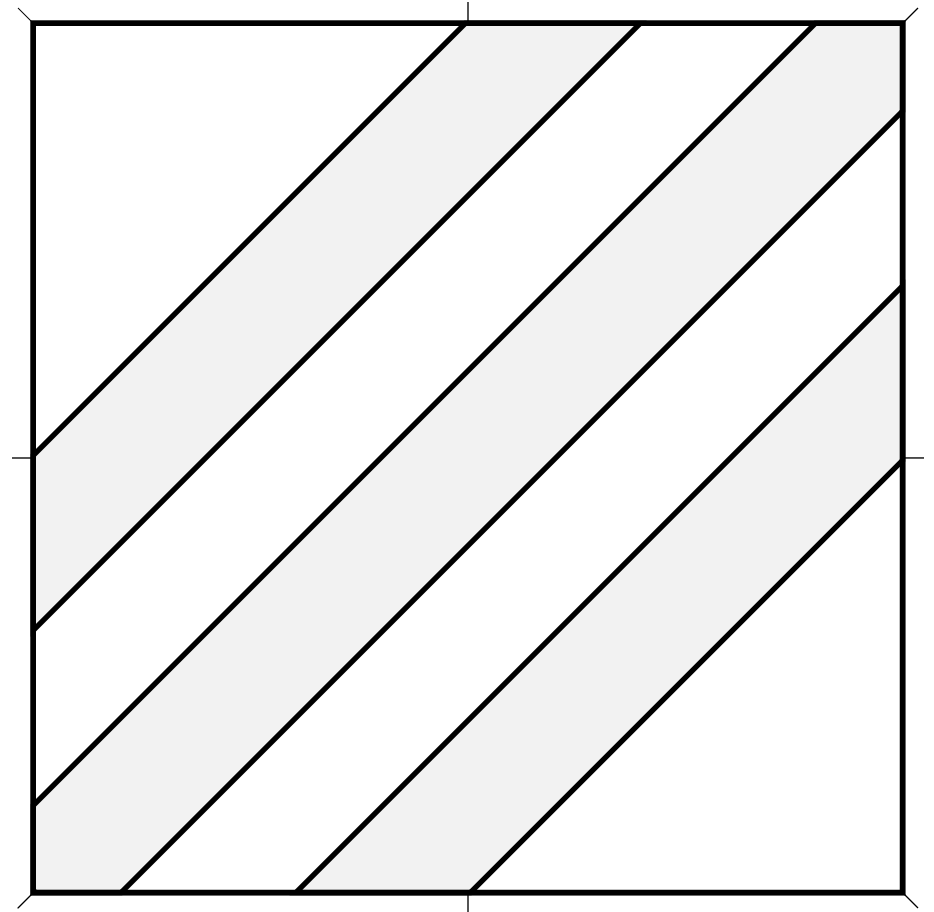
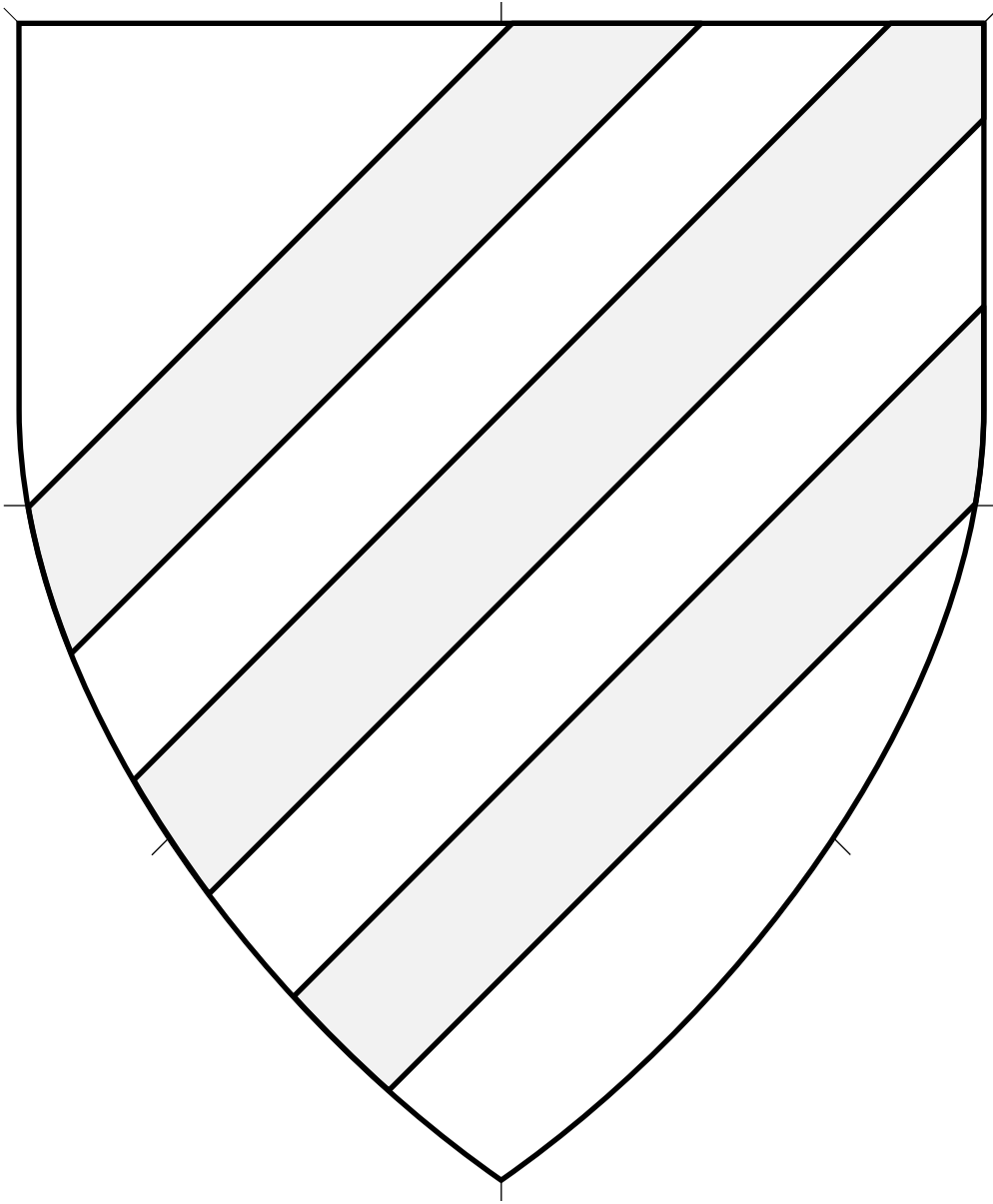

Central ordinary. Diminutive of the bend sinister.

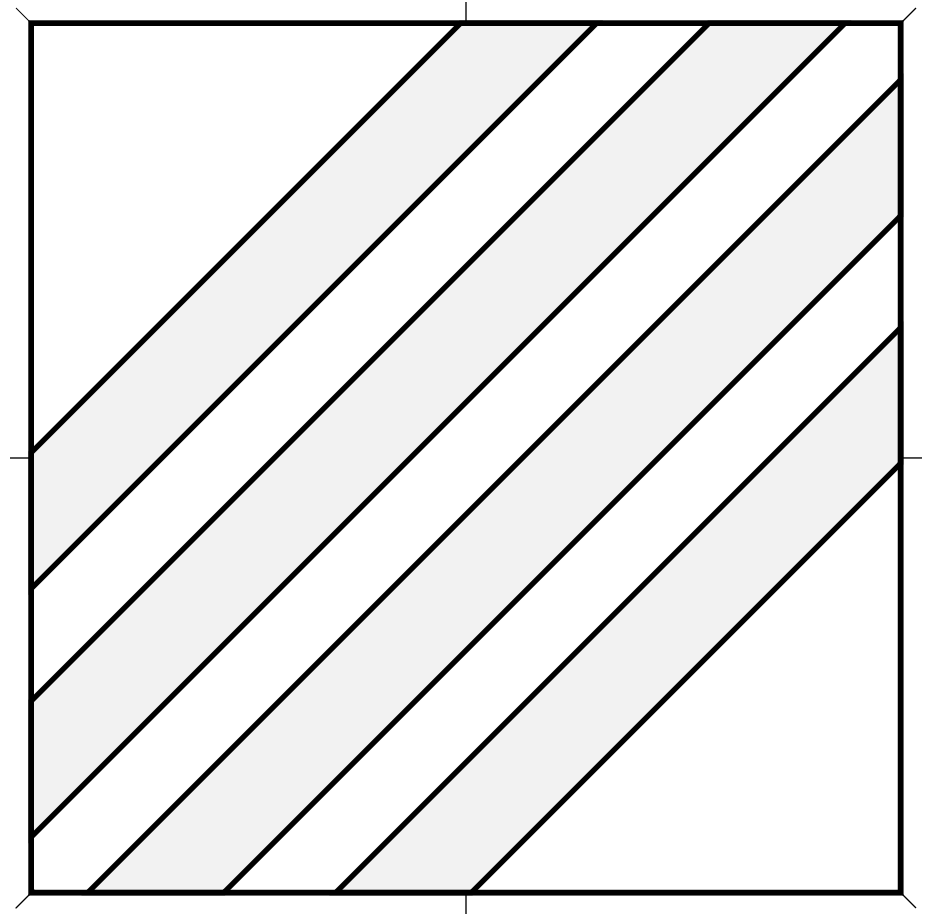
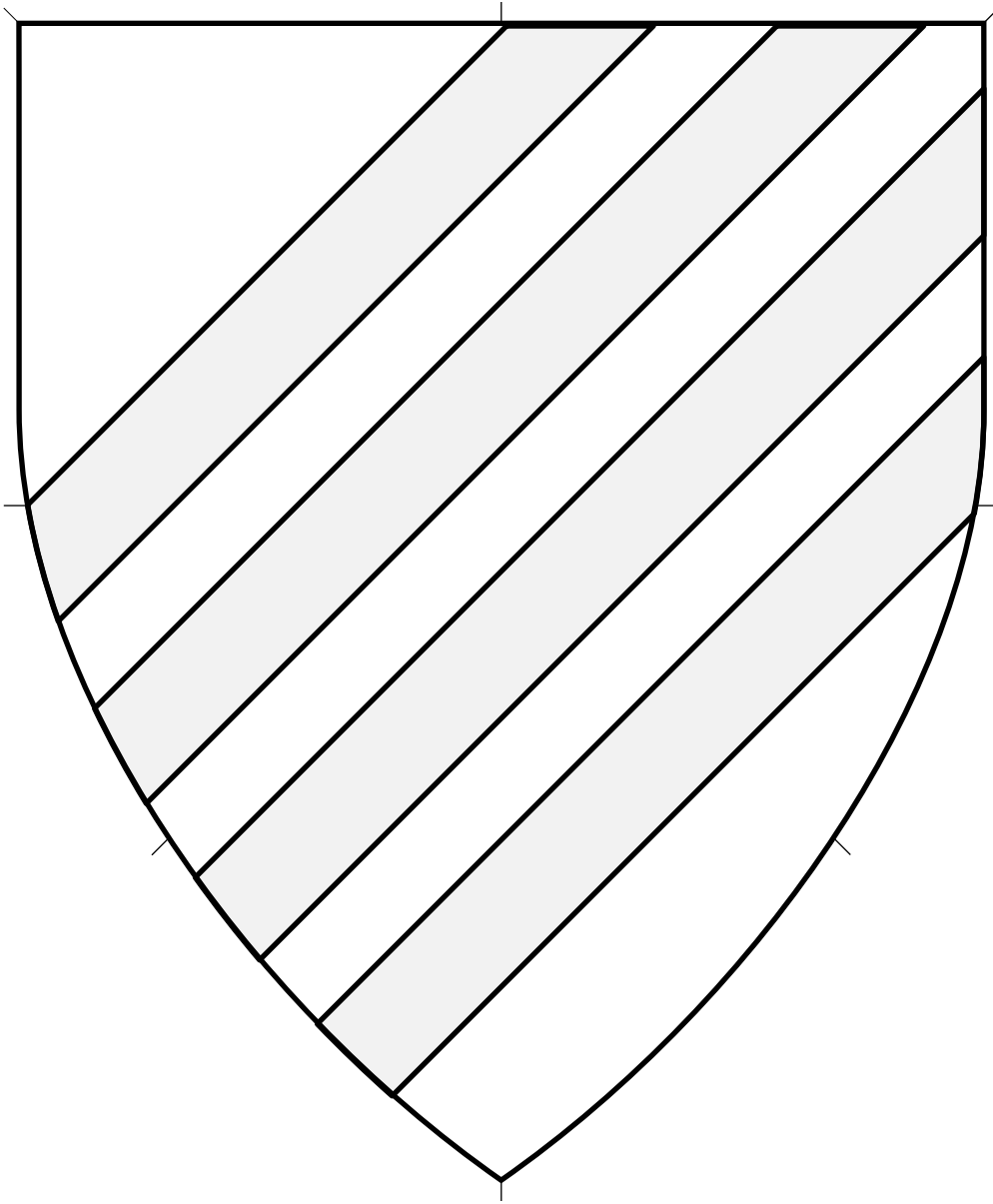

Central ordinary. Diminutive of the bend sinister.

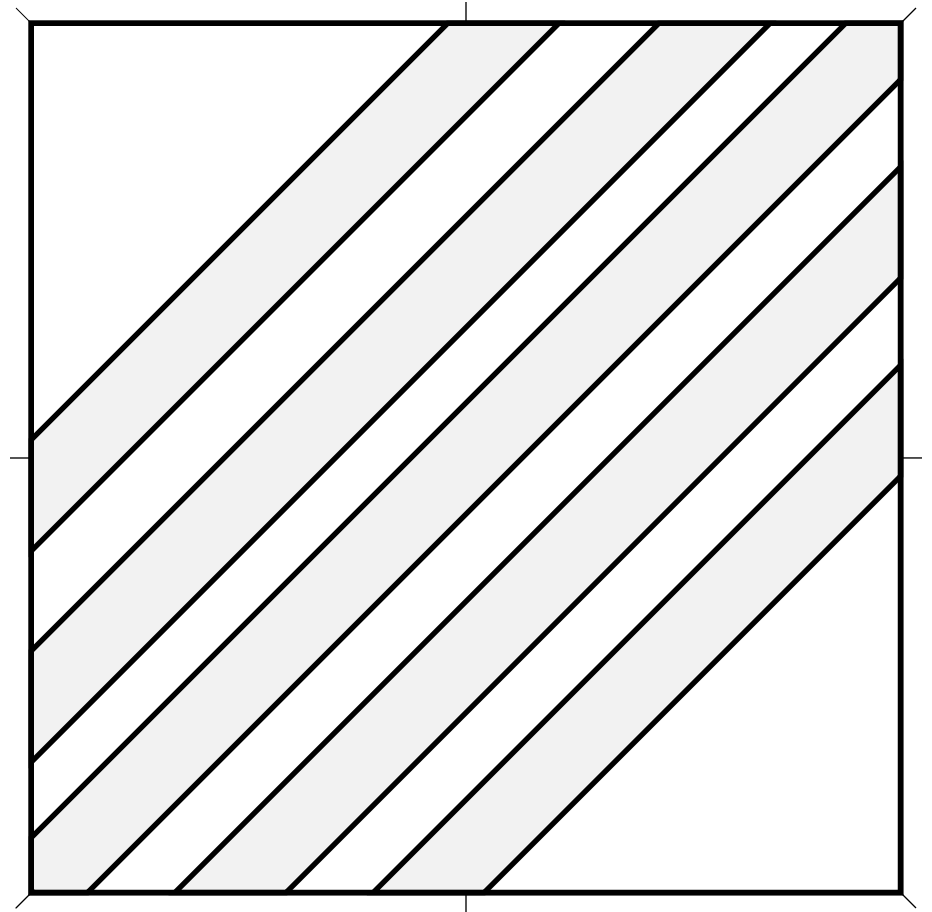
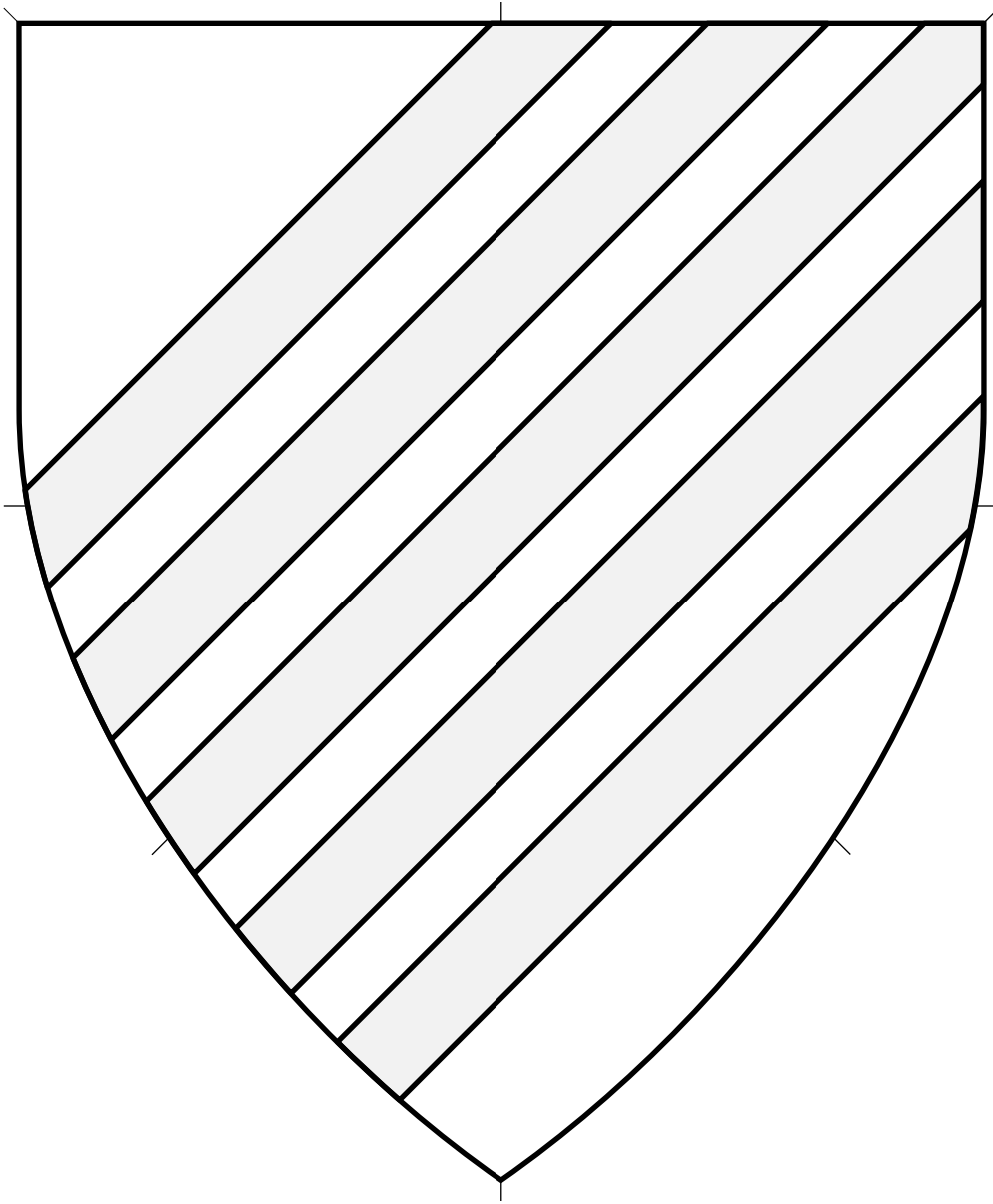

Central ordinary. Diminutive of the bend sinister.

Scarpes, 5 4.150

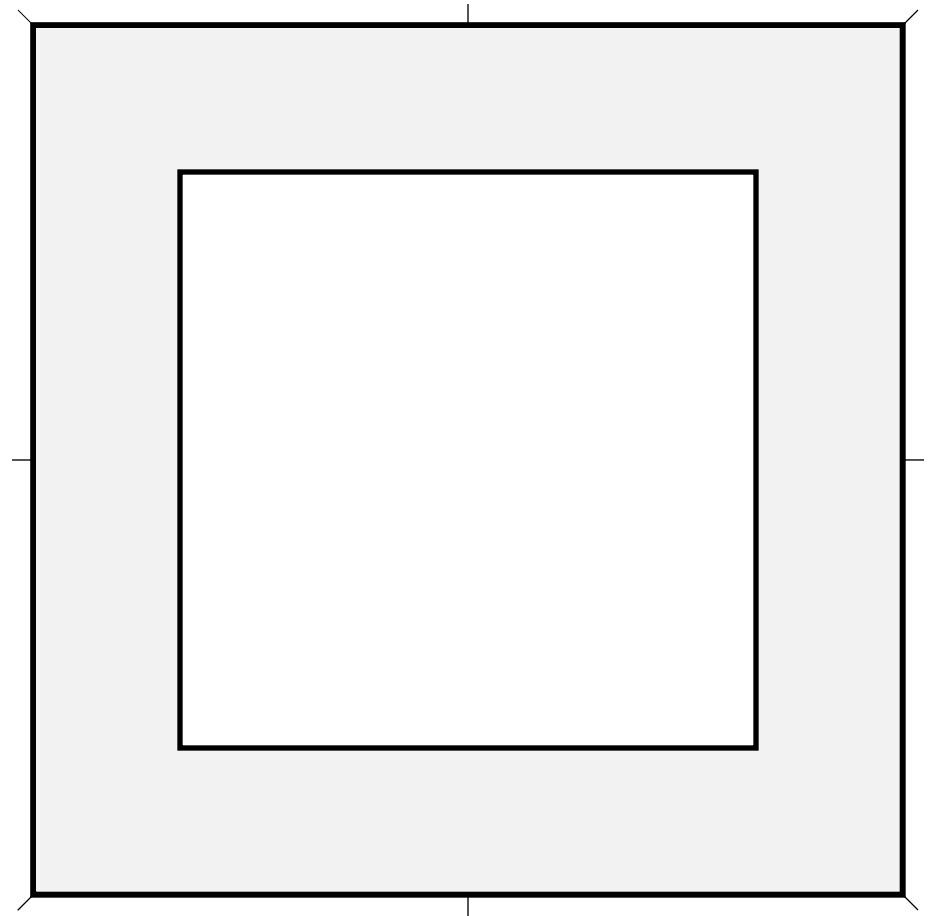
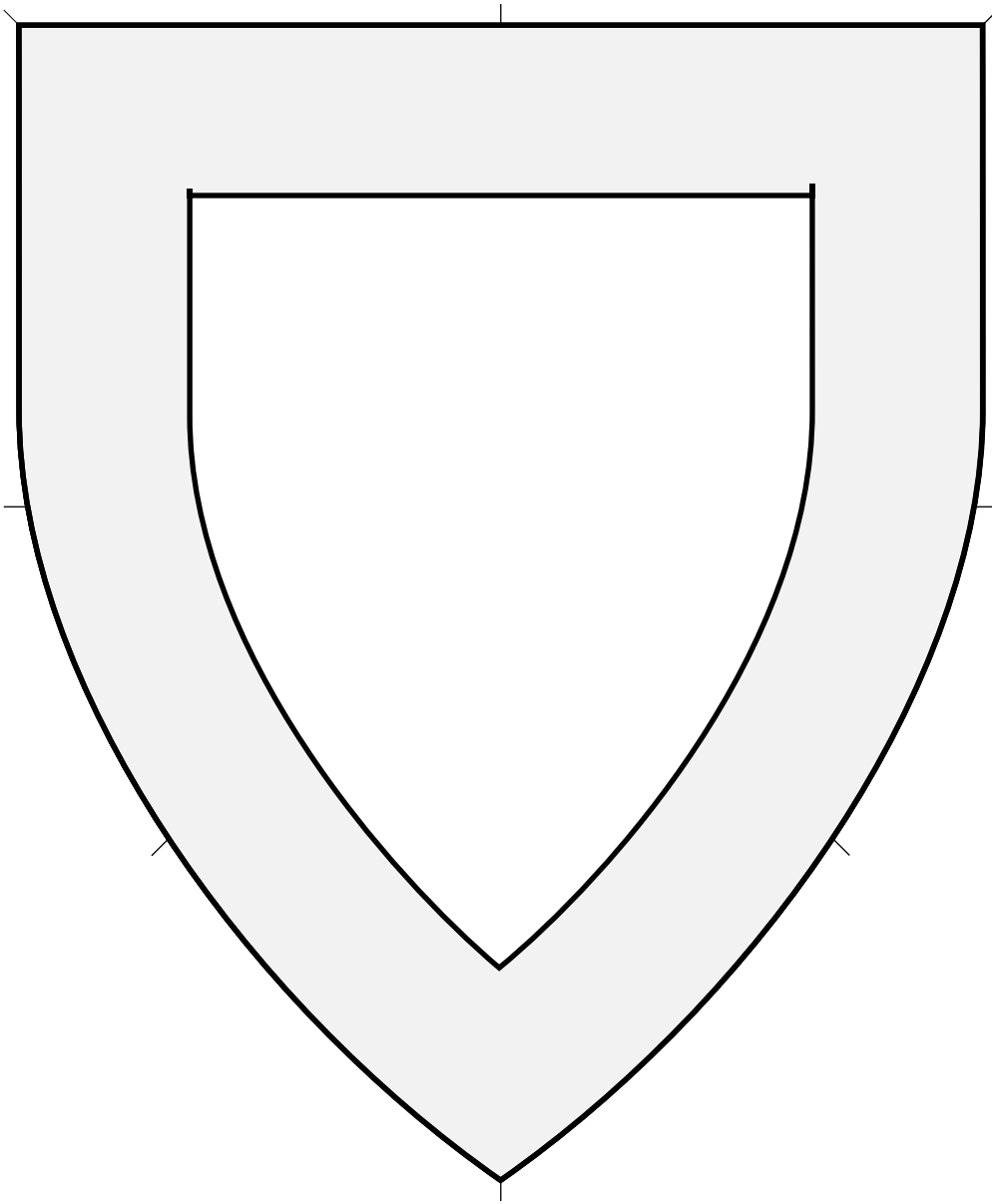

Peripheral ordinary. The thickness of the stripe can be as thin as a twelfth of the width of the device, or as wide as a sixth if charged or if drawn with a complex line. This is a full-size bordure suitable for bearing charges.

Bordure (1) 4.151

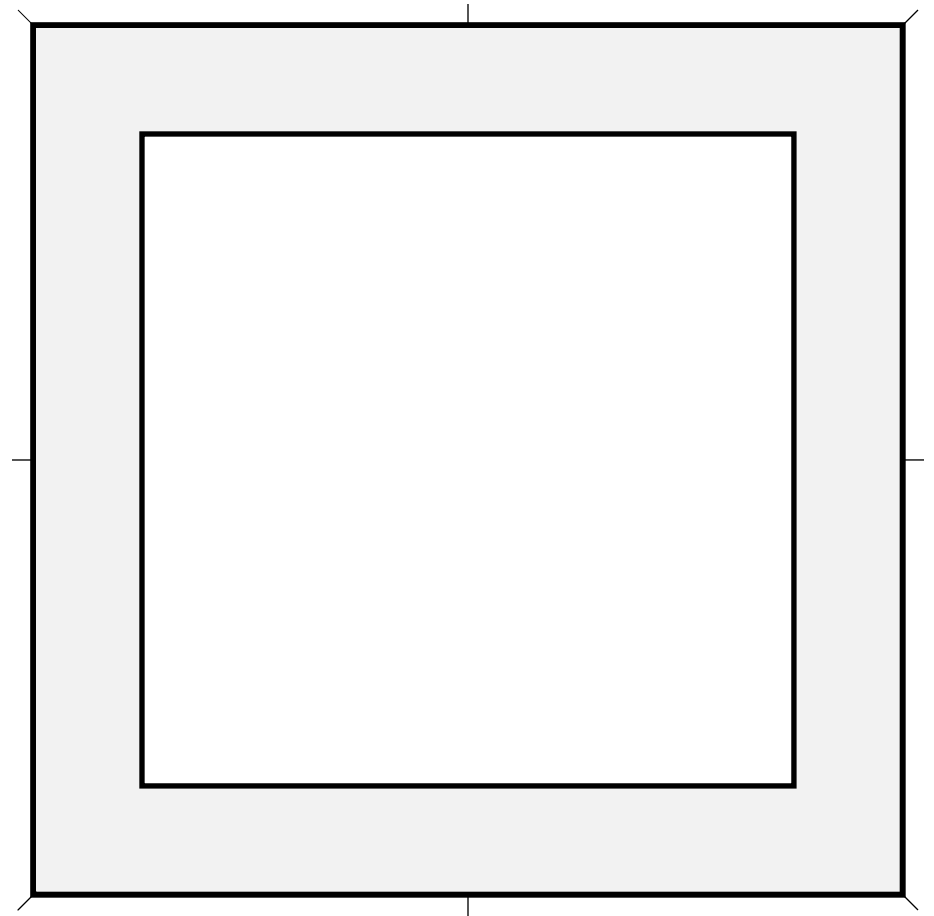
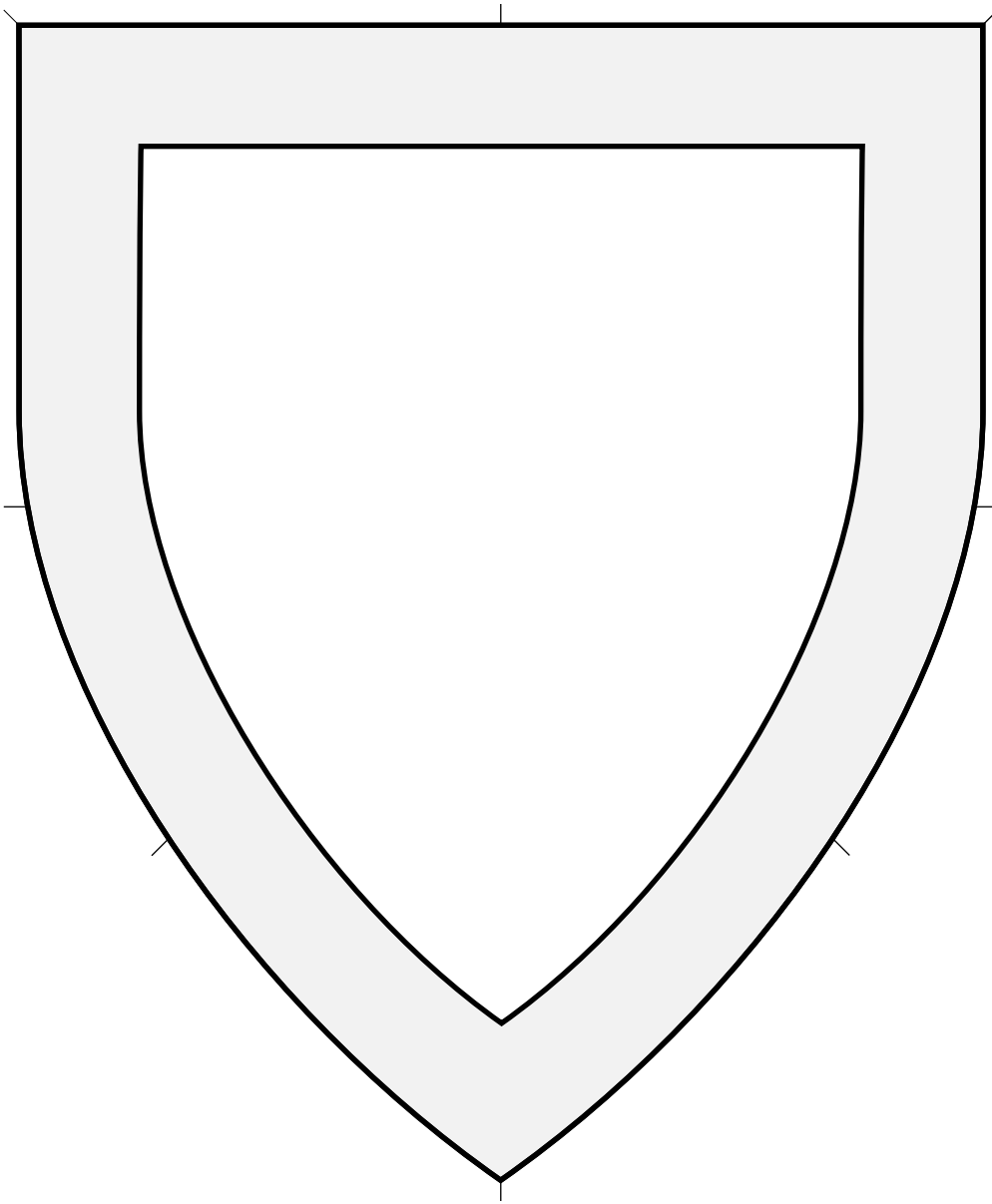

Peripheral ordinary. The thickness of the stripe can be as thin as a twelfth of the width of the device, or as wide as a sixth if charged or if drawn with a complex line. This is a medium-size bordure.

Bordure (2) • 4.152

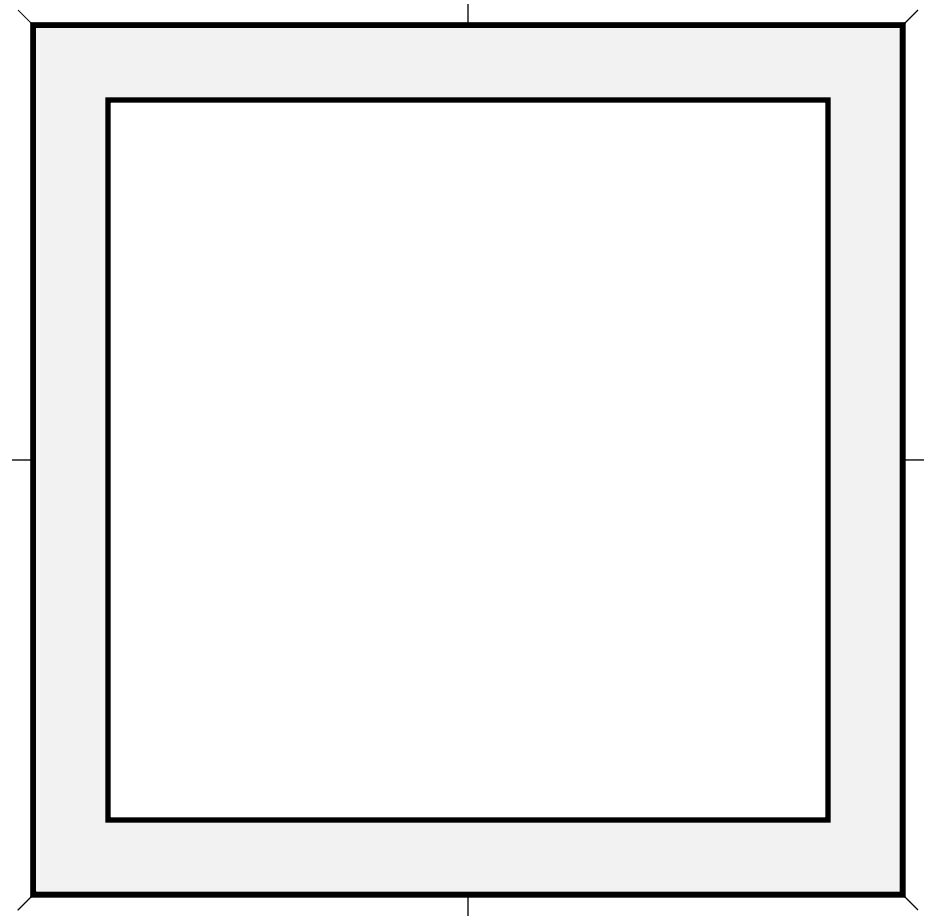
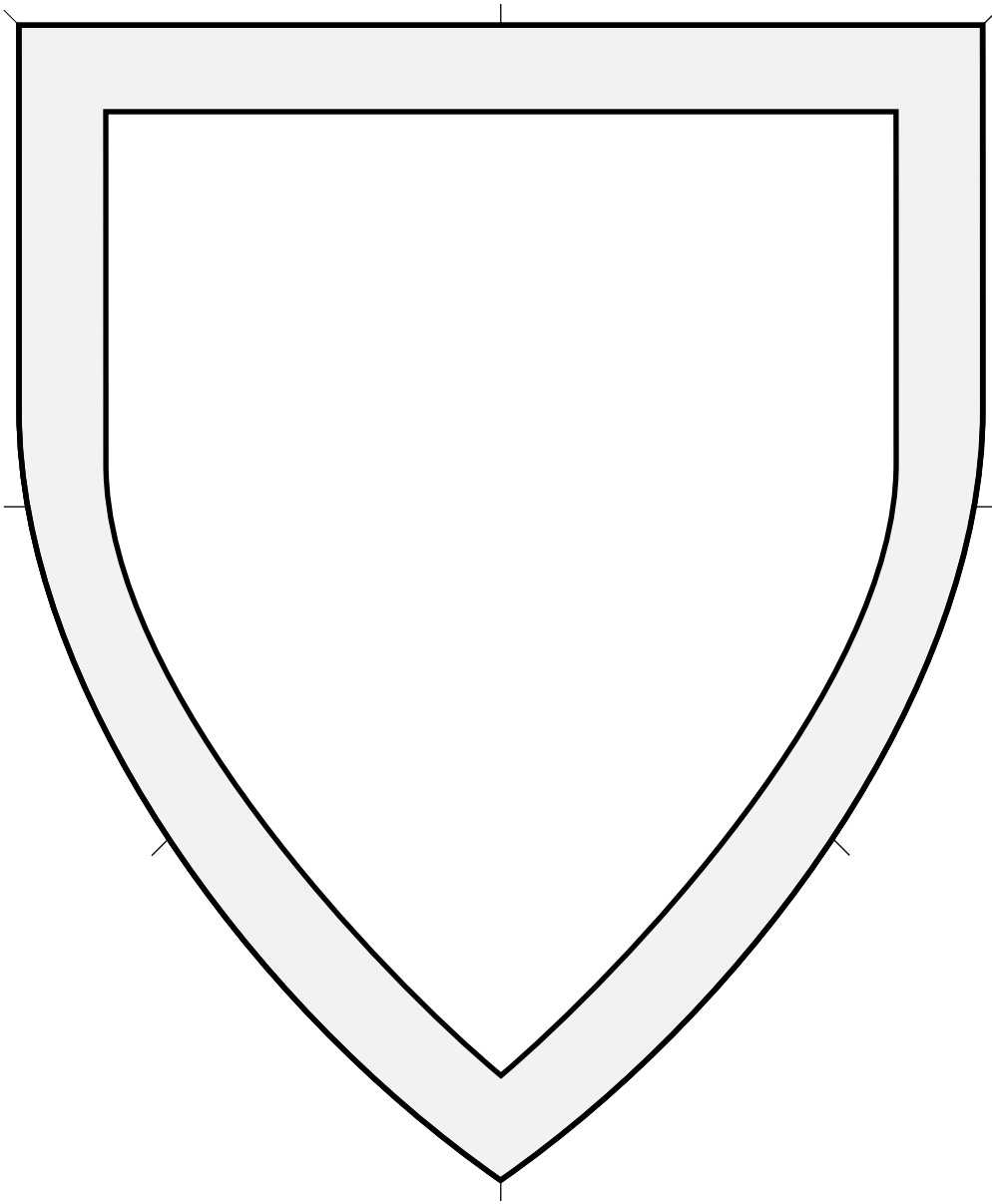

Peripheral ordinary. The thickness of the stripe can be as thin as a twelfth of the width of the device, or as wide as a sixth if charged or drawn with a complex line. This is a thin bordure.

Bordure (3) 4.153

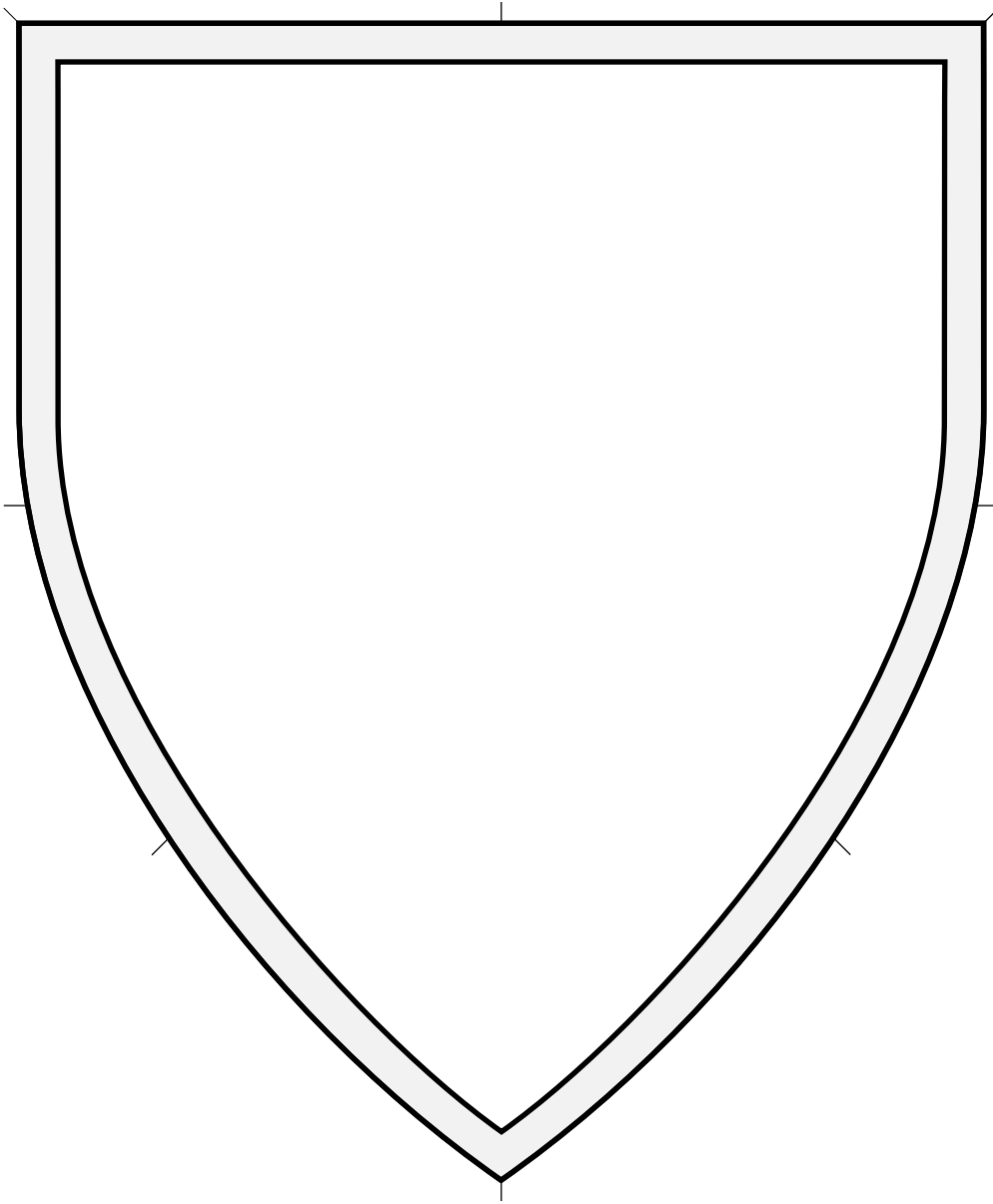

Peripheral ordinary.

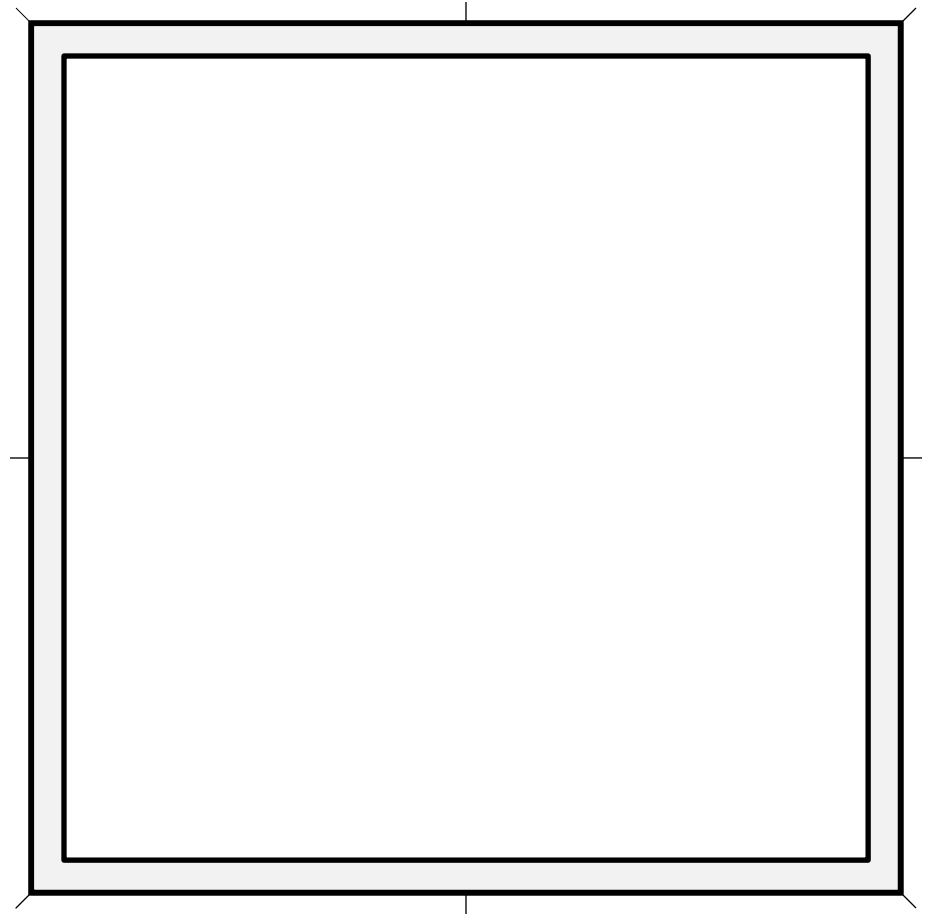

Bordure (4) 4.154

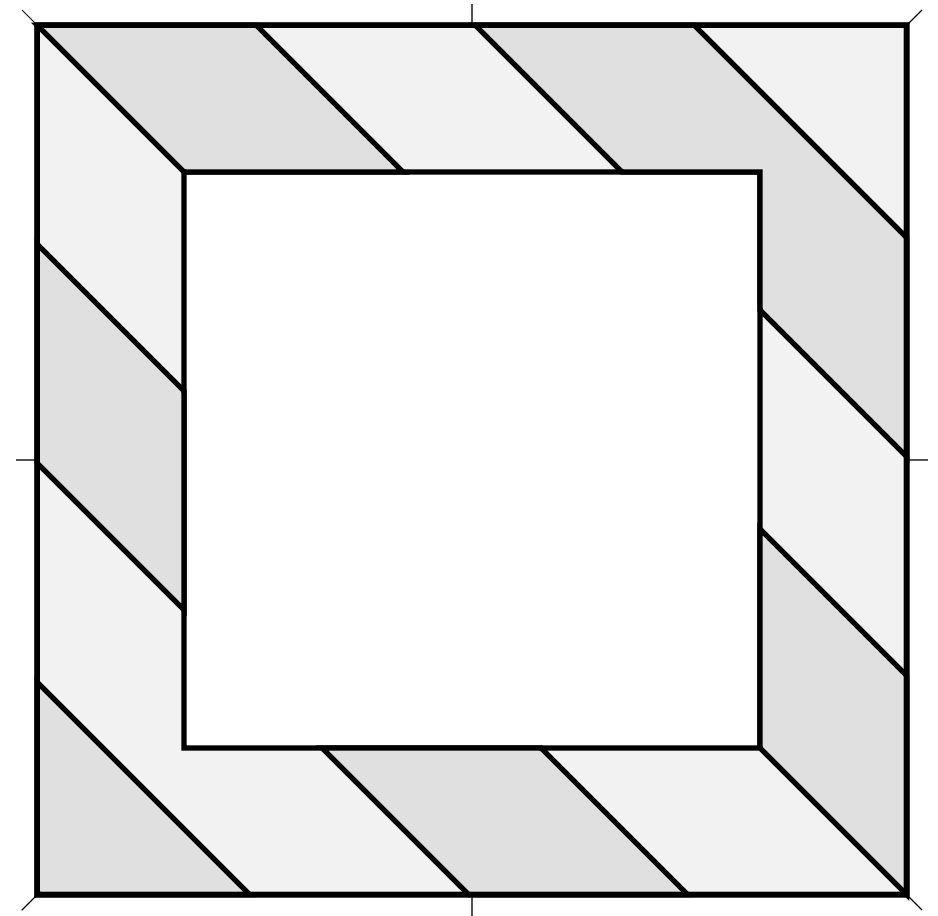
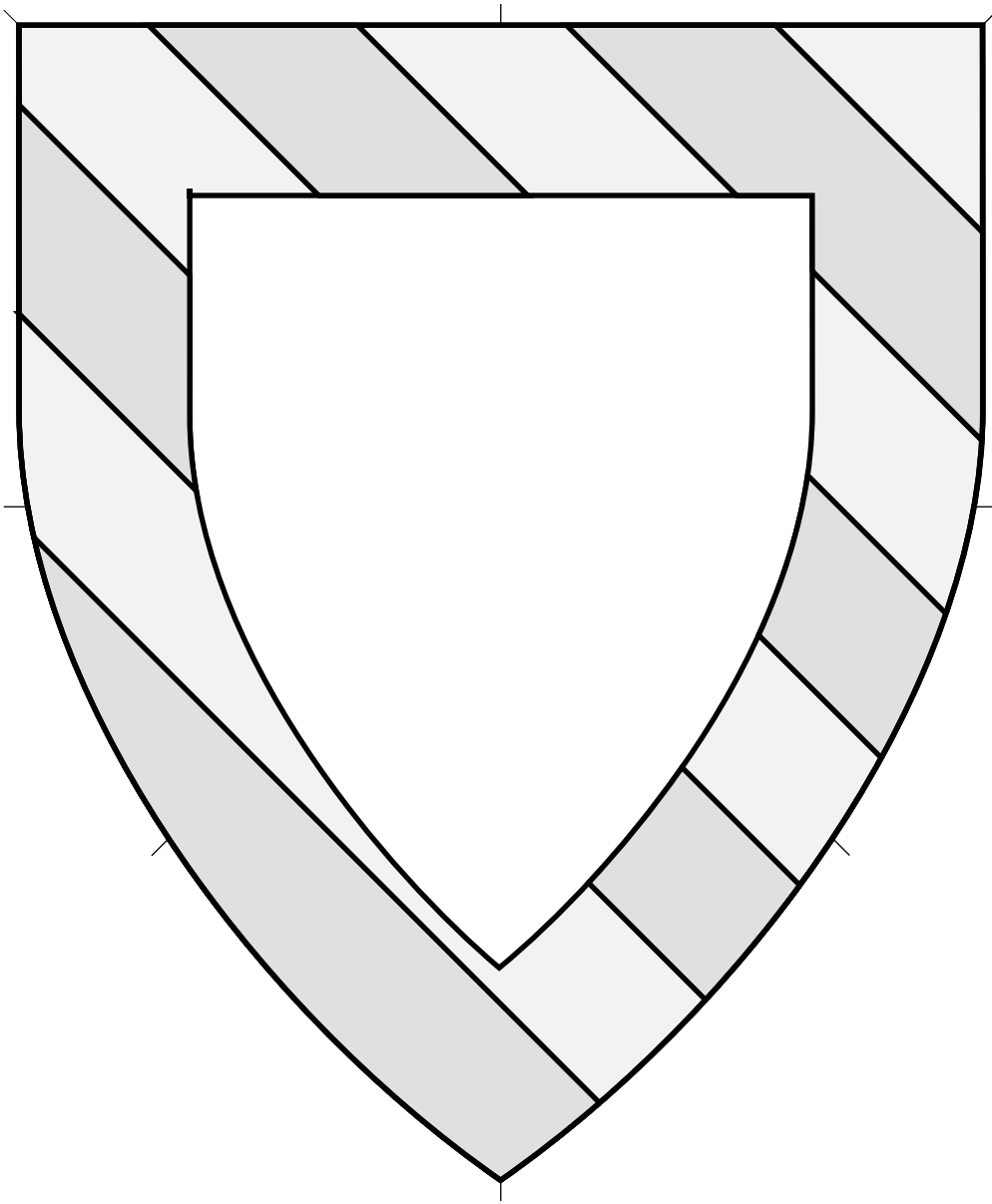

Peripheral ordinary. This bordure is separated into alternating stripes of contrasting tinctures.

Bordure Bendy • 4.155

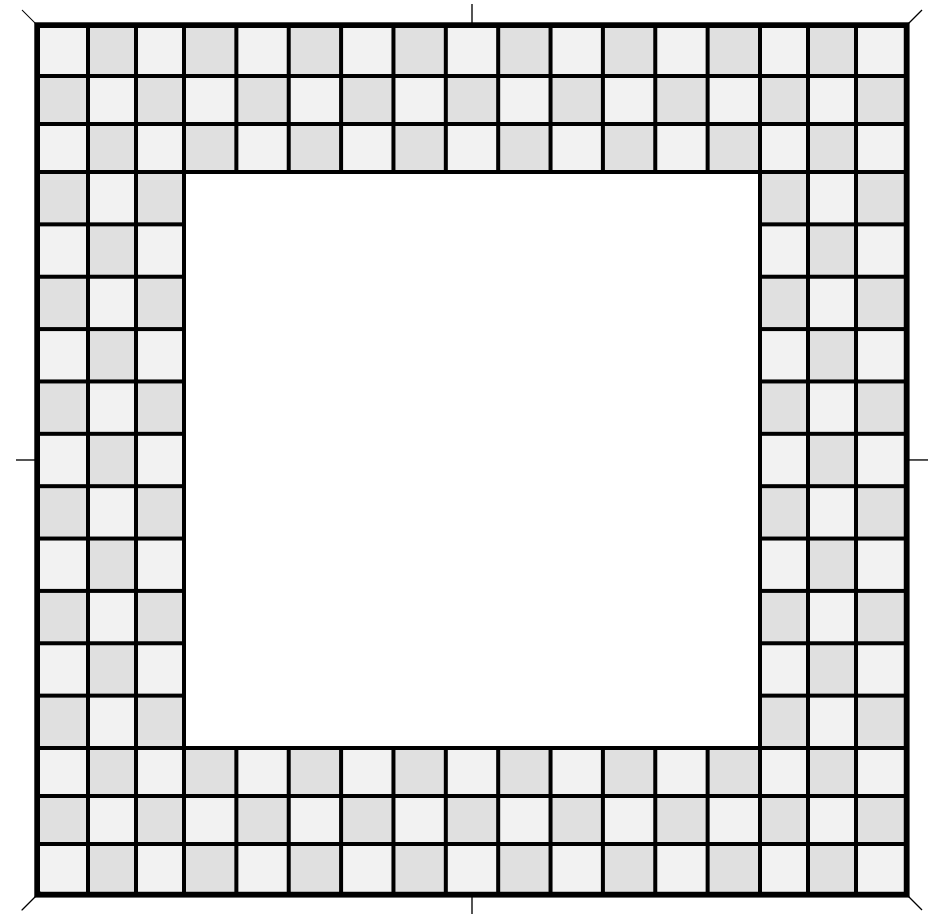
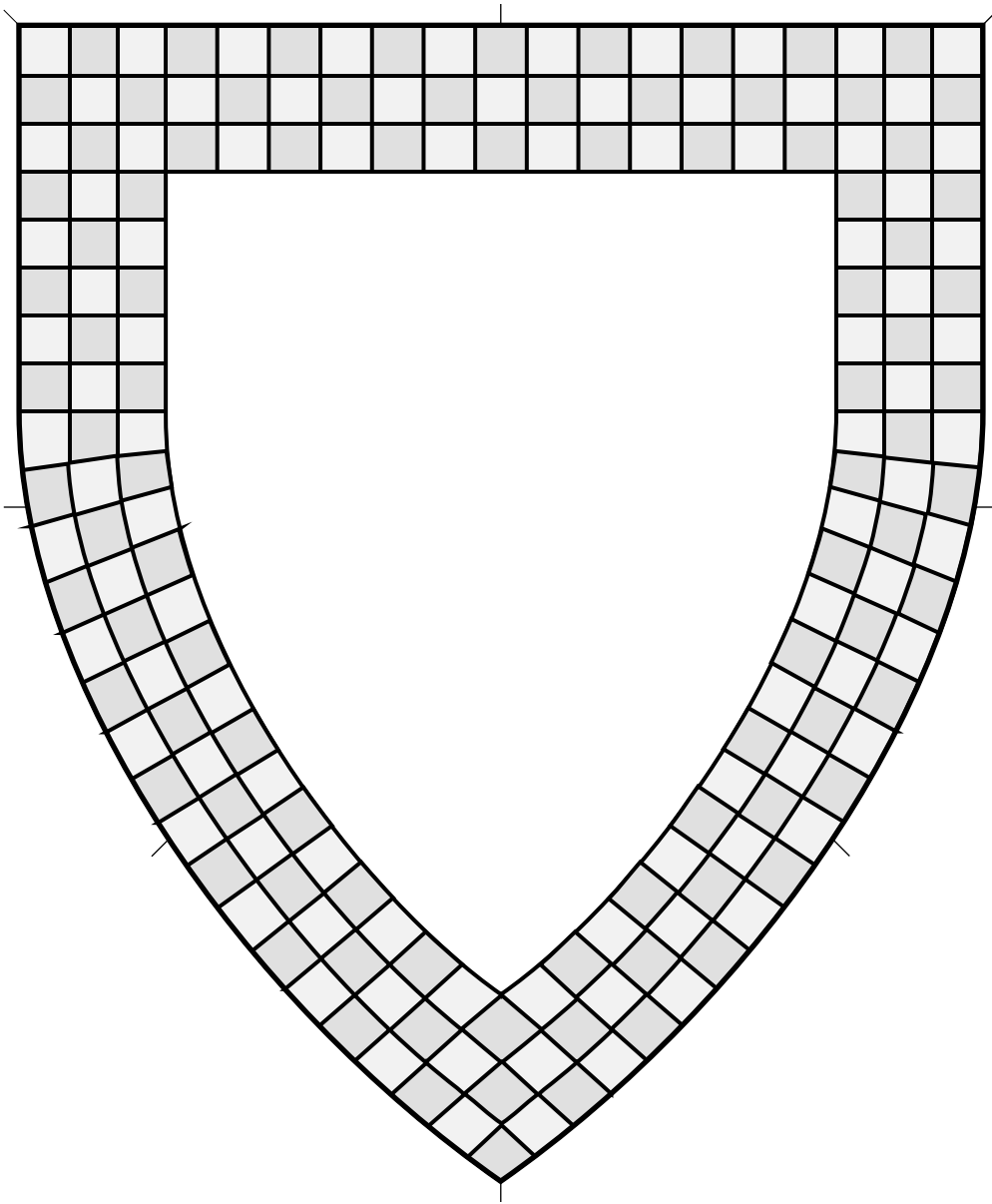

Peripheral ordinary. This bordure is separated into alternating squares of contrasting tinctures.

Bordure Checky (1) • 4.156

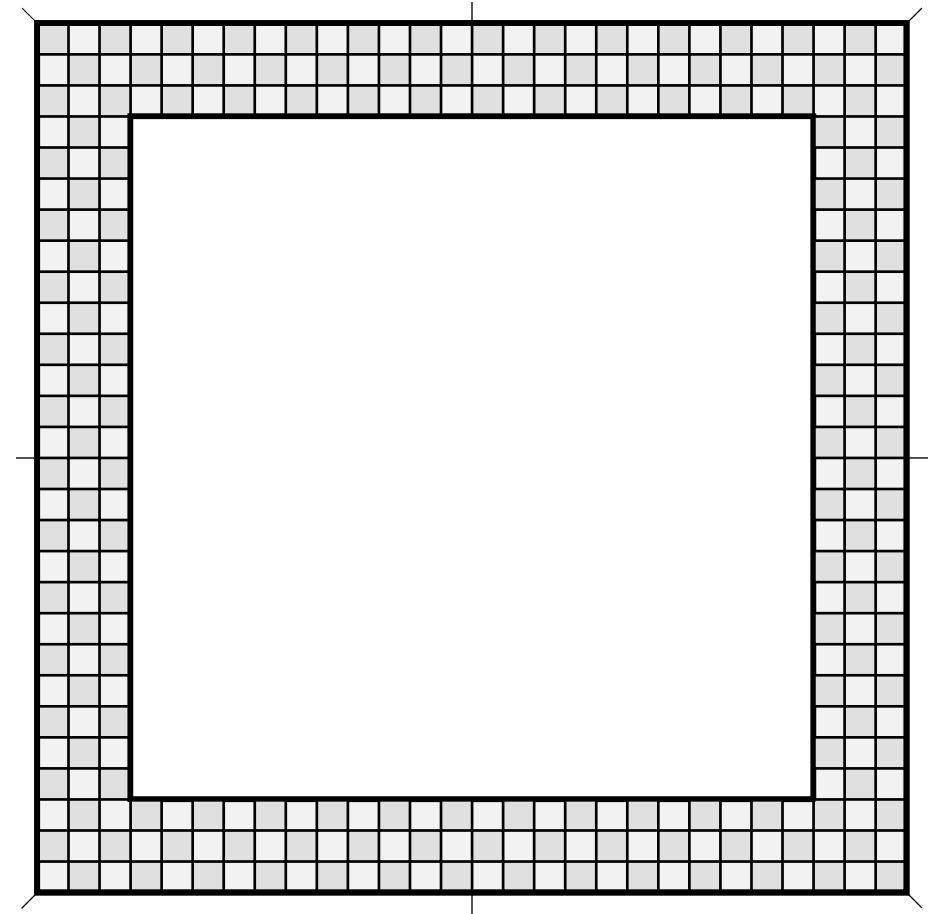
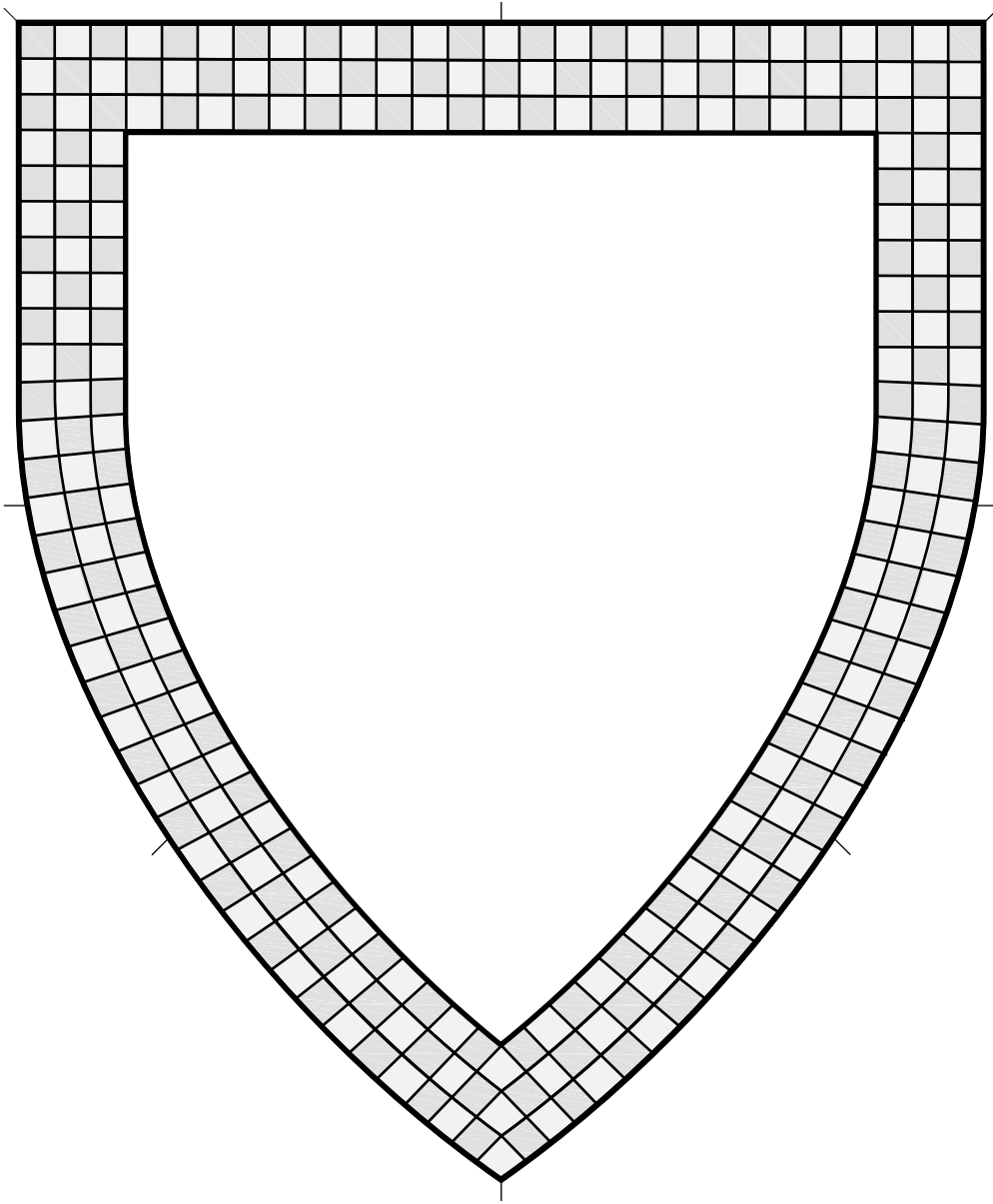

Peripheral ordinary. This bordure is separated into alternating squares of contrasting tinctures.
Artist: Niccolo da Palermo.

Bordure Checky (2) 4.157

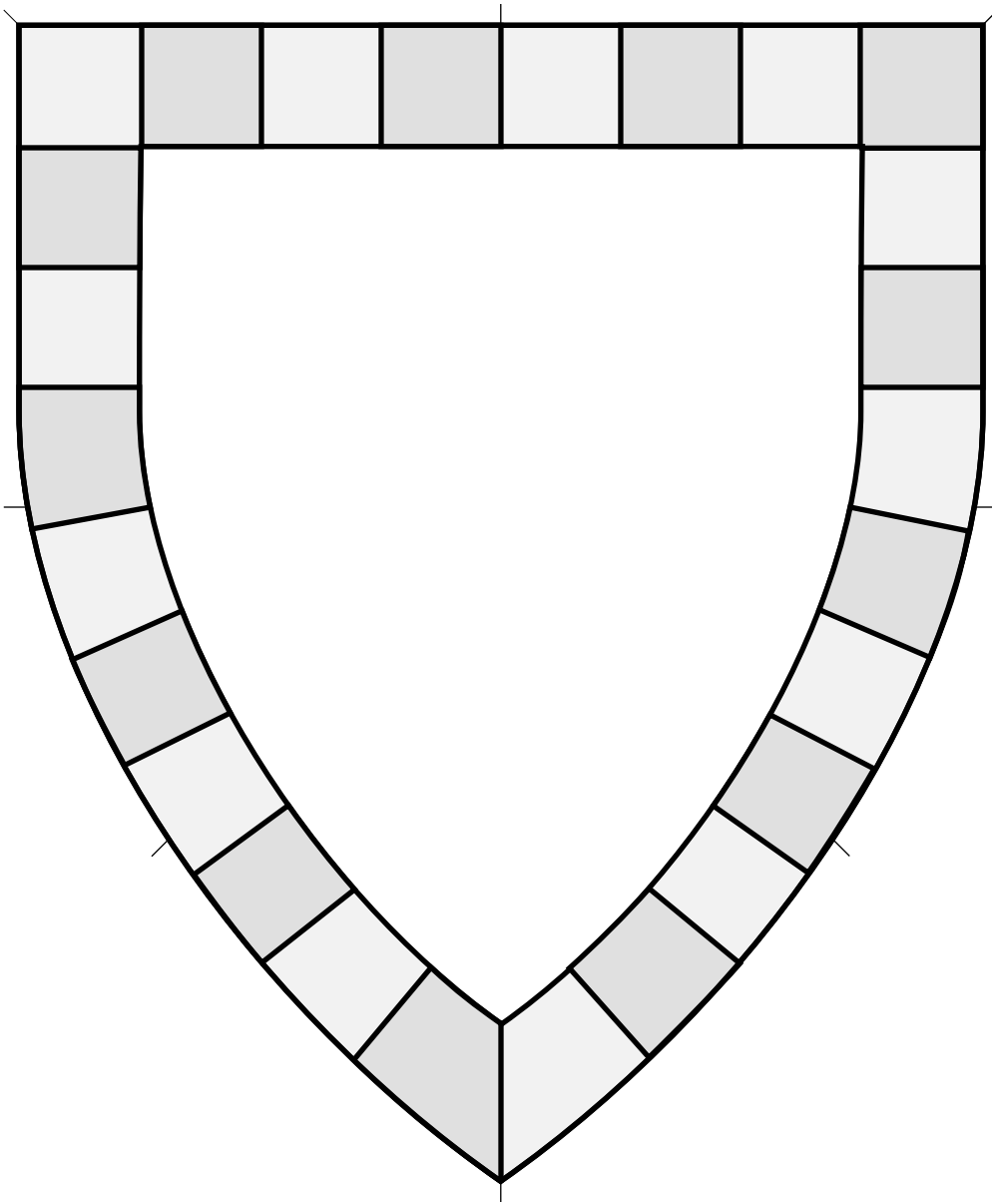

Peripheral ordinary. This bordure is separated into alternating squares of contrasting tinctures.

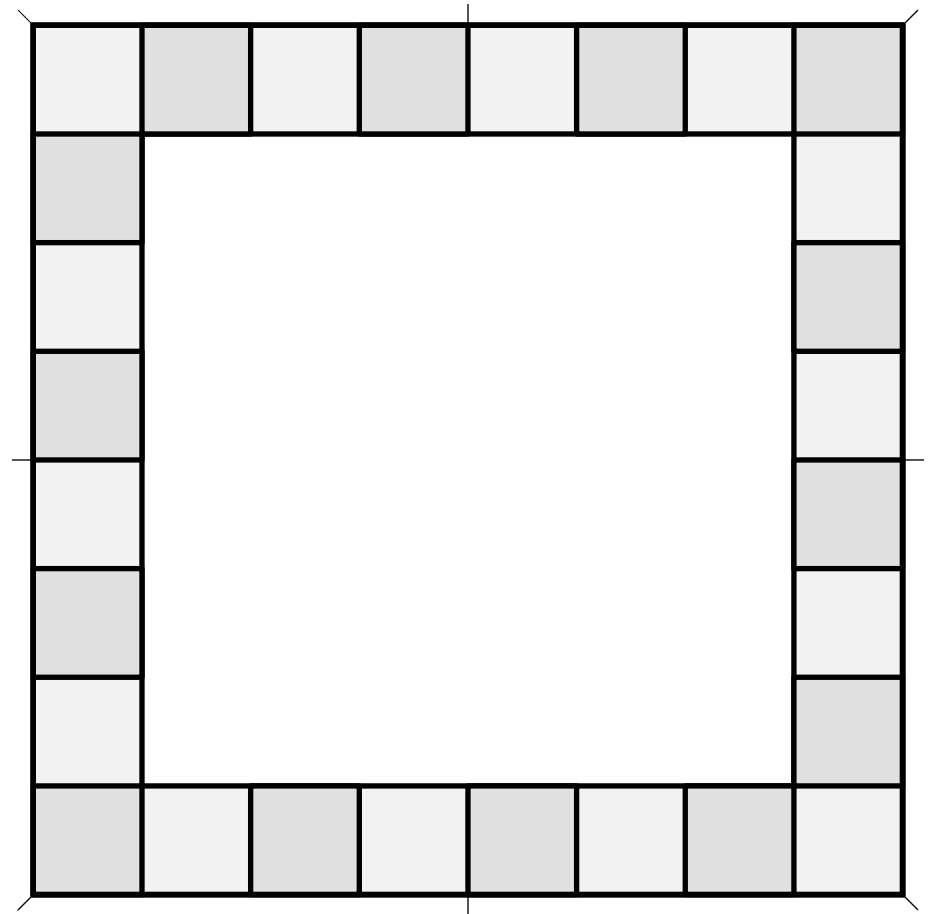

Bordure Compony (1) 4.158

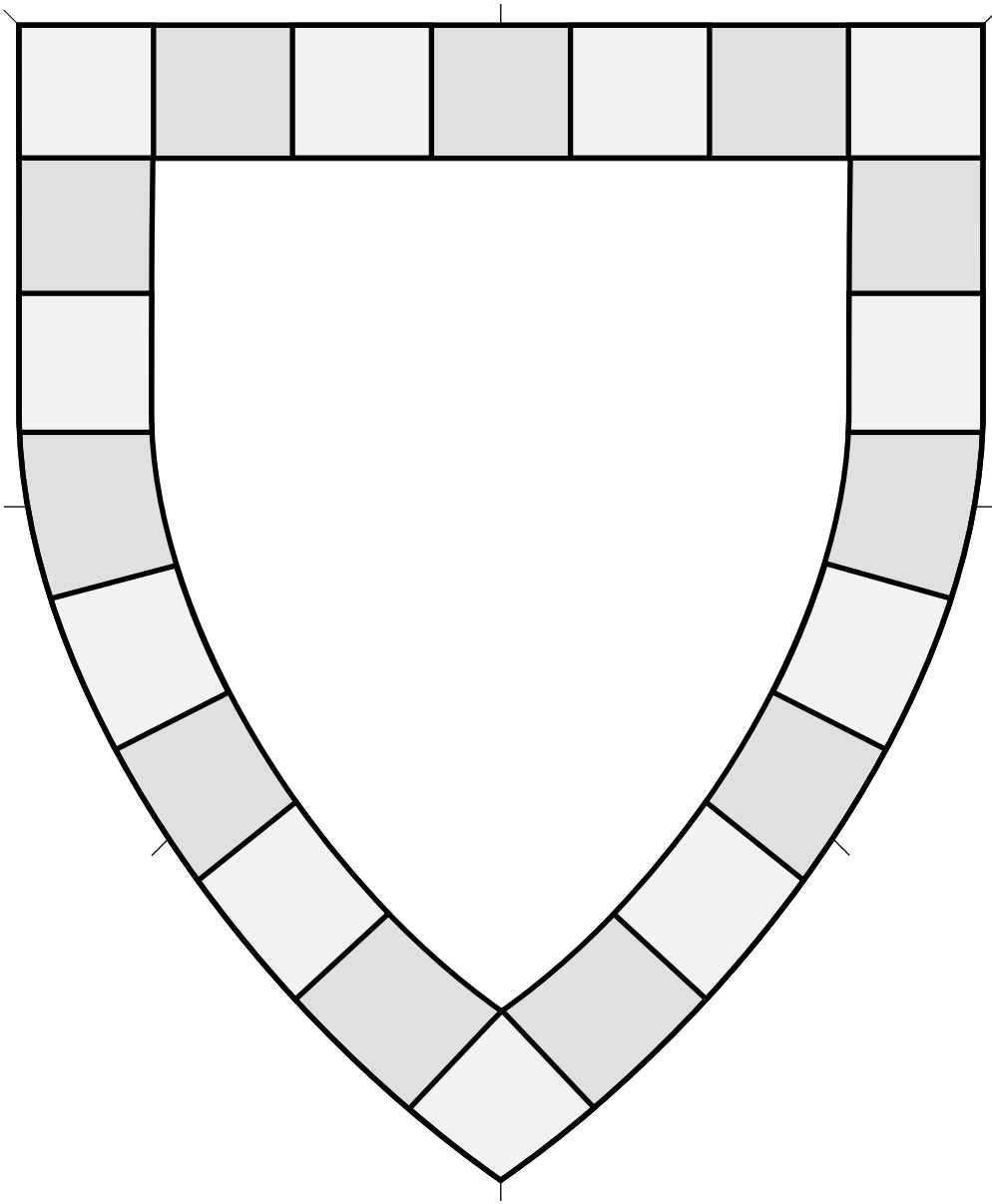

Peripheral ordinary. This bordure is separated into alternating squares of contrasting tinctures.

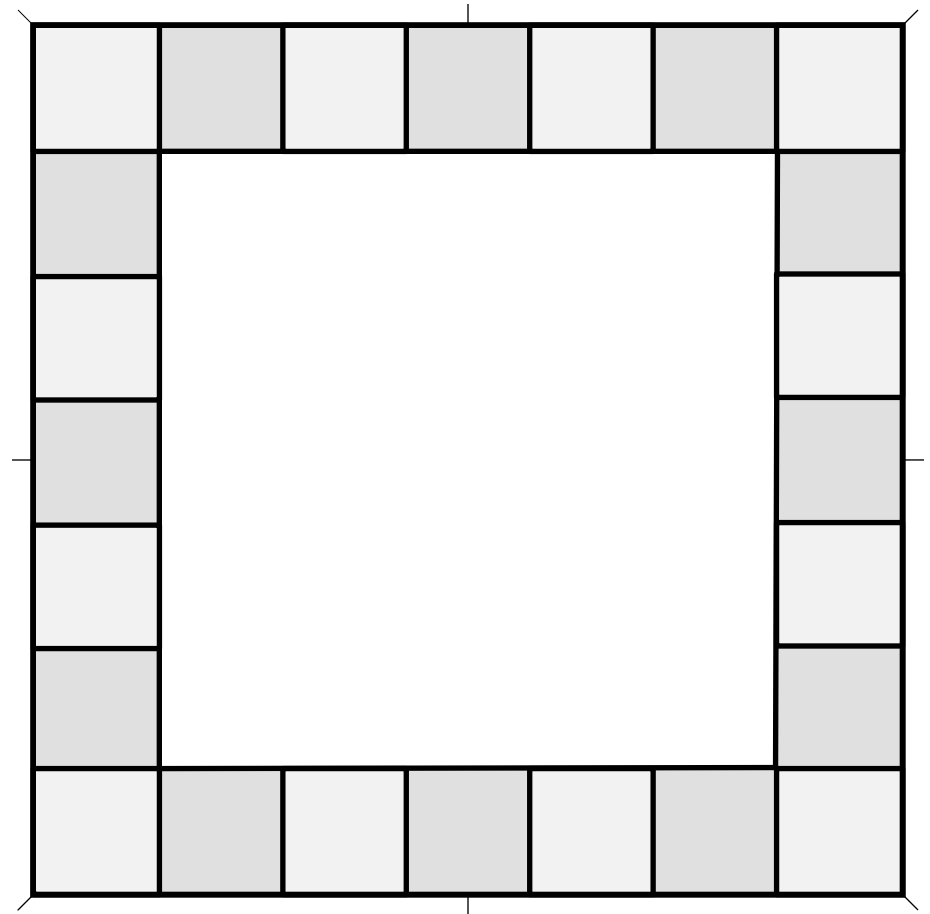

Bordure Compony (2) 4.159

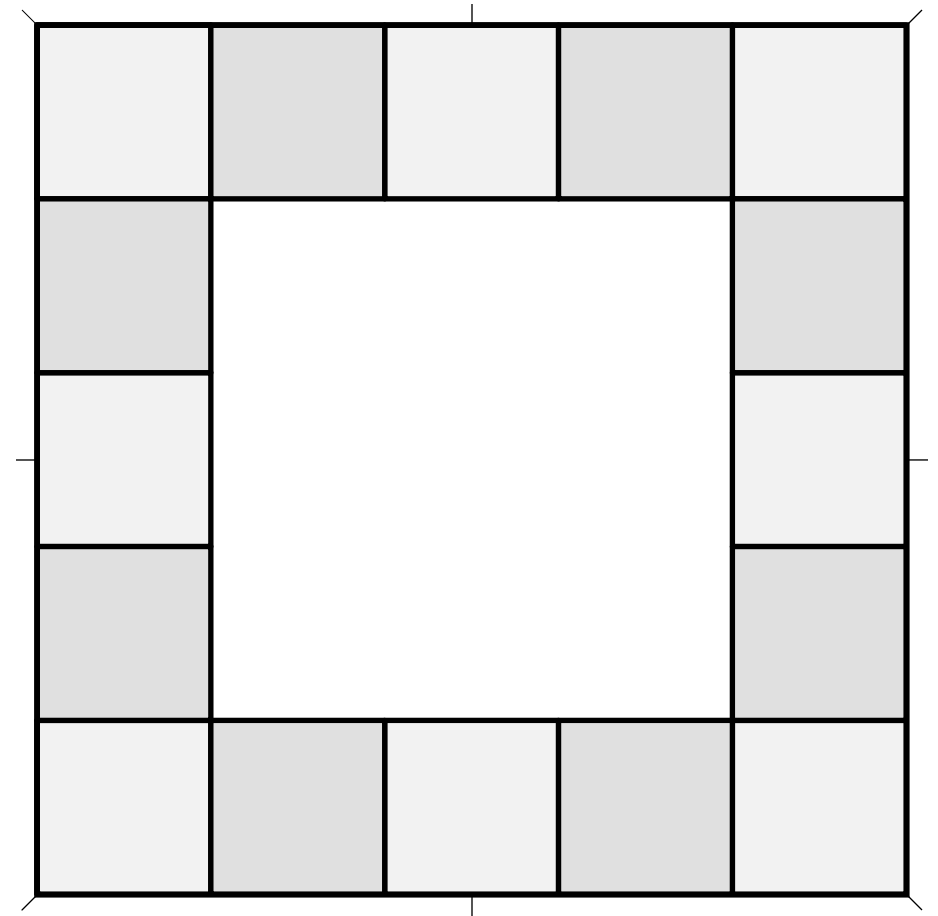
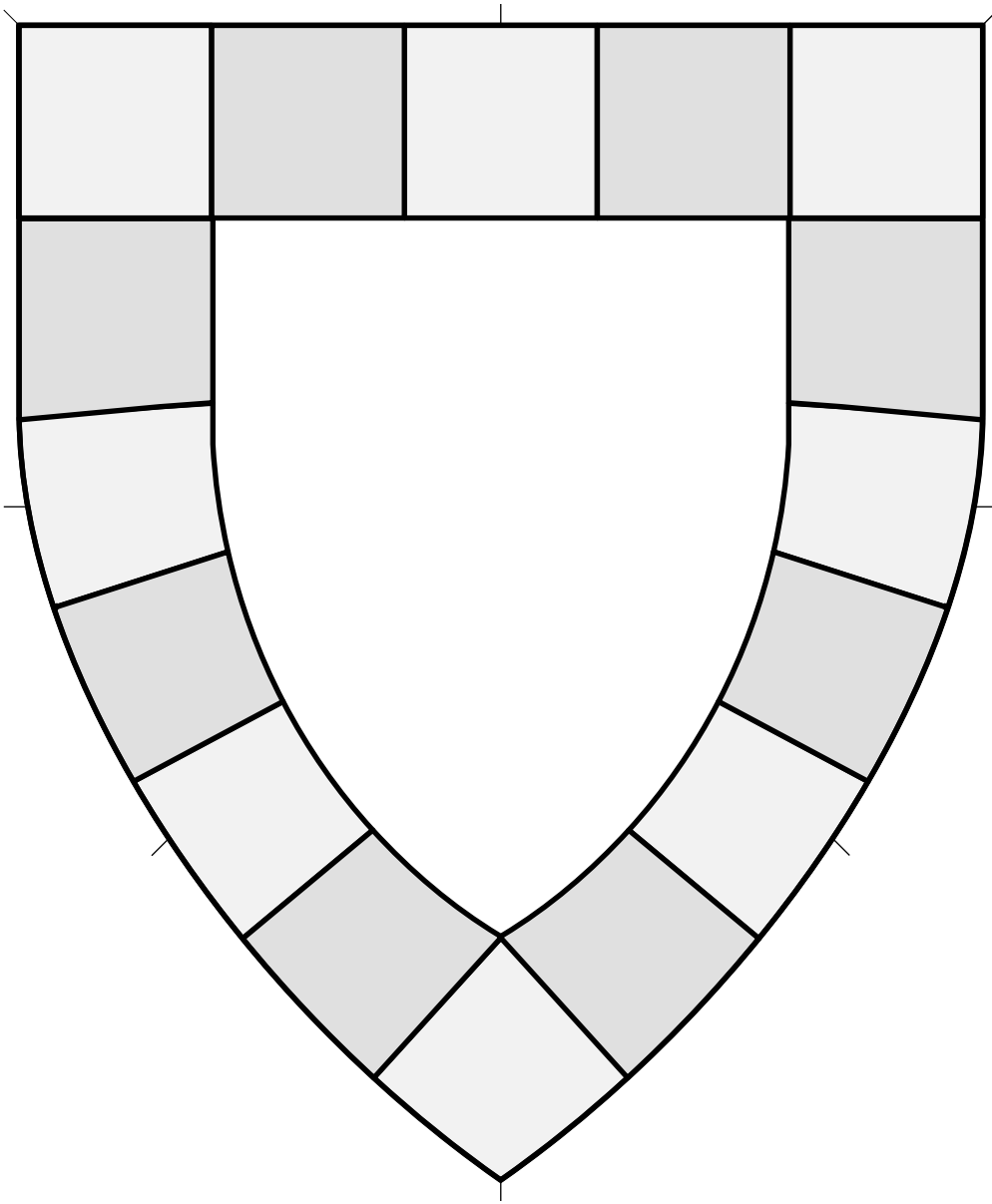

Peripheral ordinary.

Source: Viking Answer Lady SVG Images For Heraldry.
Artist: Gunnvôr silfrahárr. Adapted by Mathghamhain Ua Ruadháin.

Bordure Compony (3) 4.160

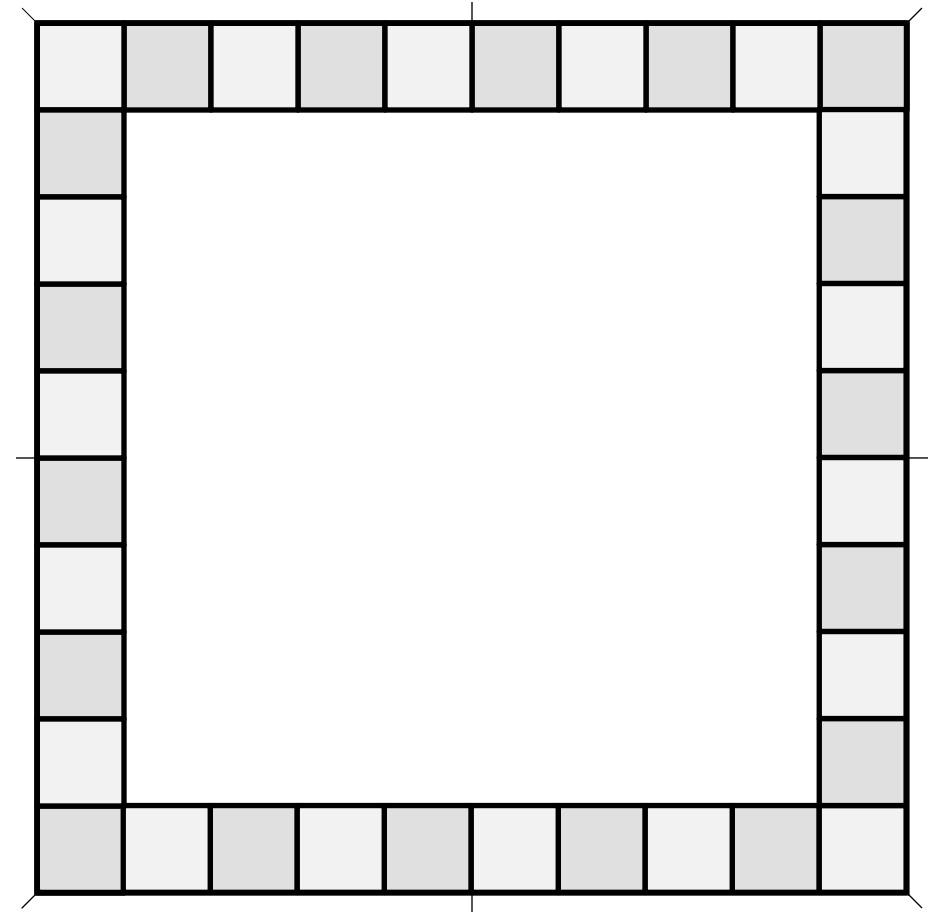
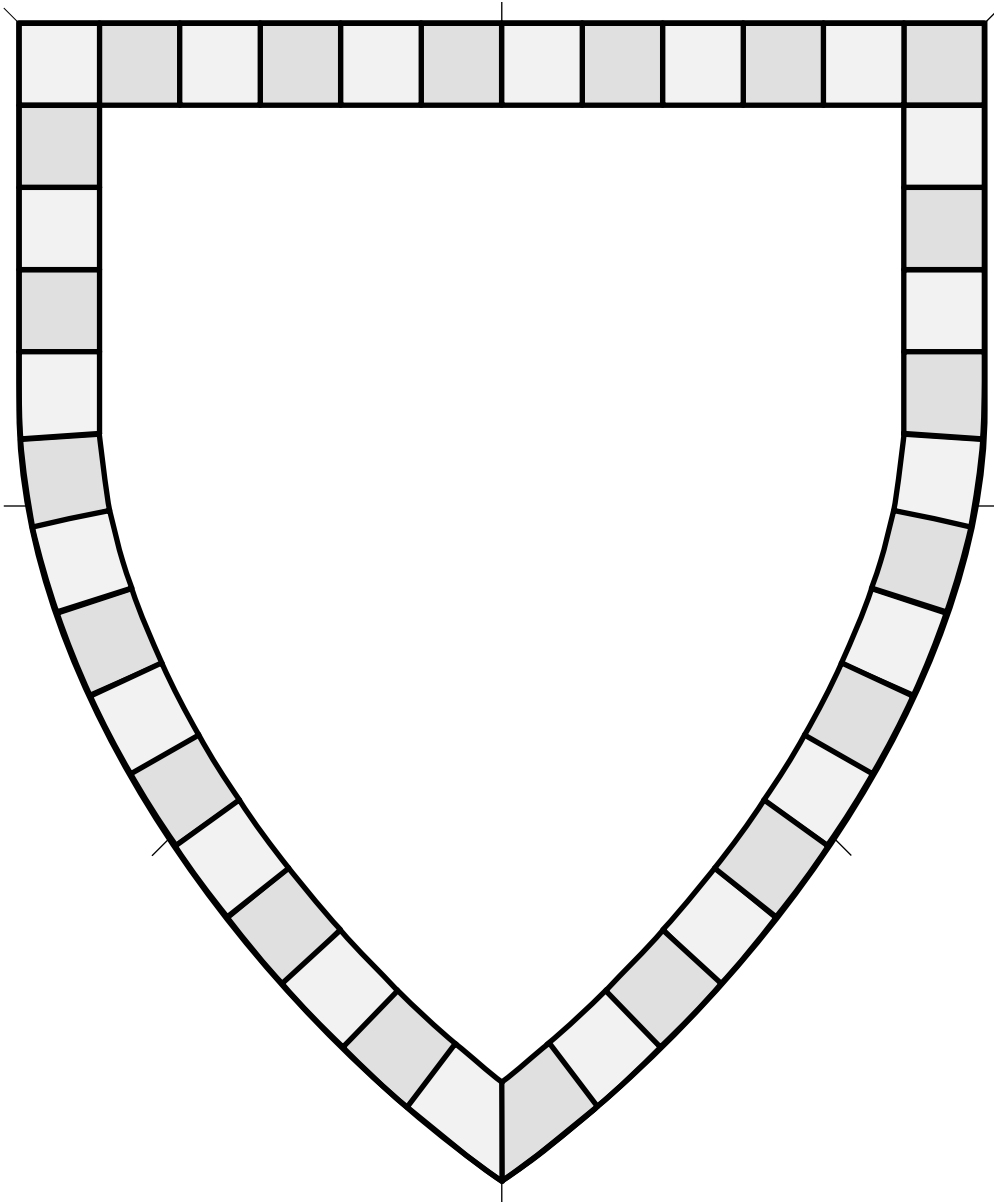

Peripheral ordinary.

Source: Viking Answer Lady SVG Images For Heraldry.
Artist: Gunnvôr silfrahárr. Adapted by Mathghamhain Ua Ruadháin.

Bordure Compony (4) 4.161

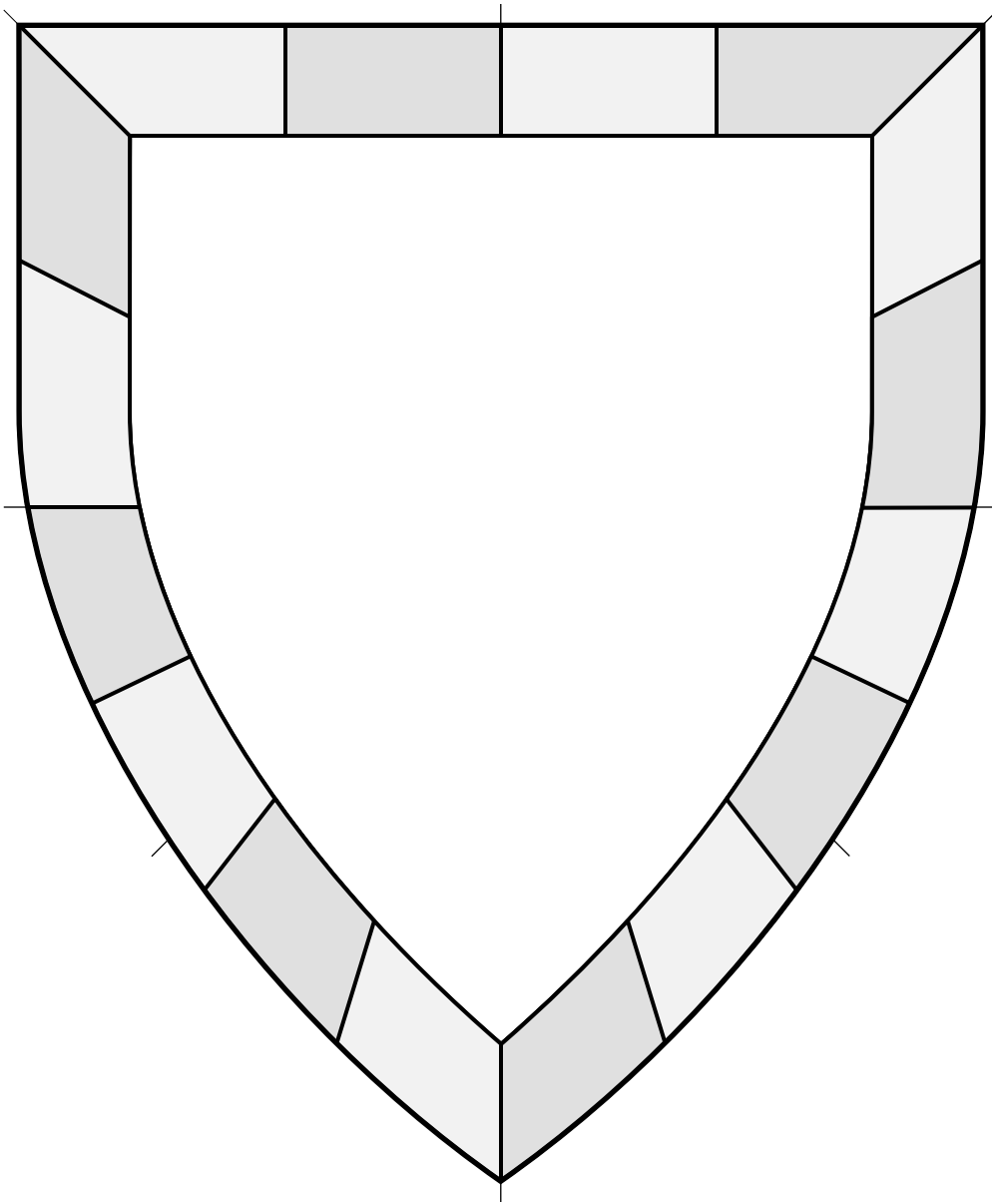

Peripheral ordinary.

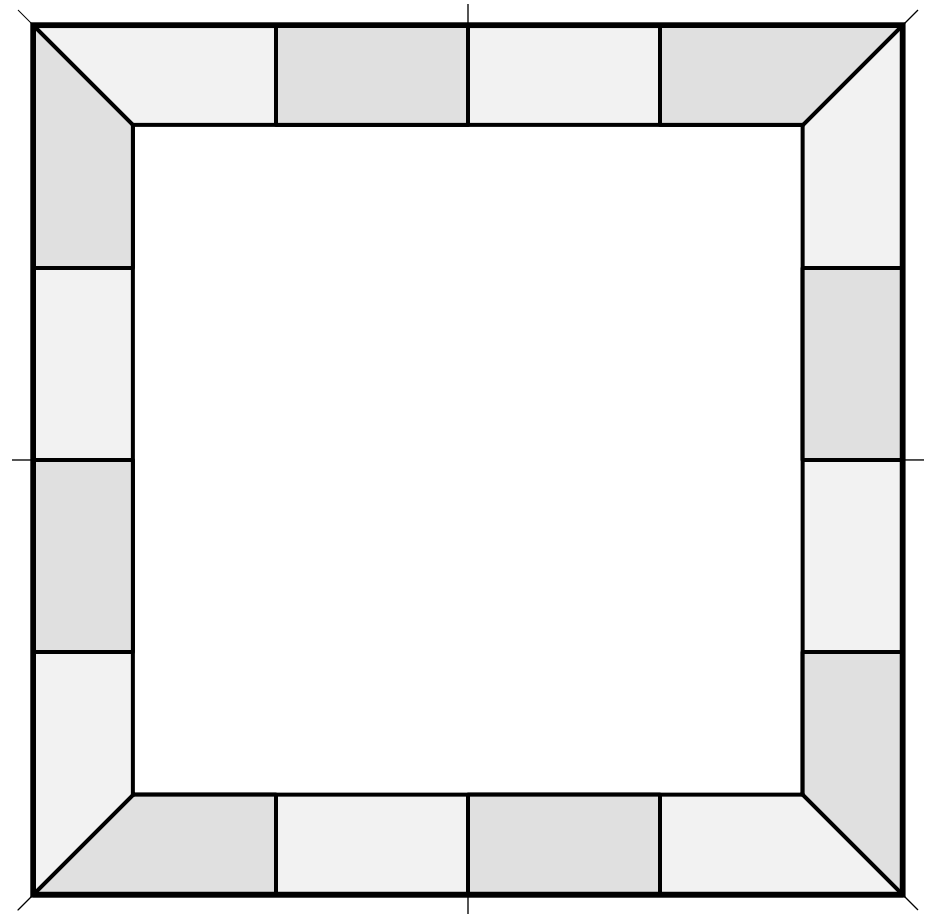

Bordure Compony (5) 4.162

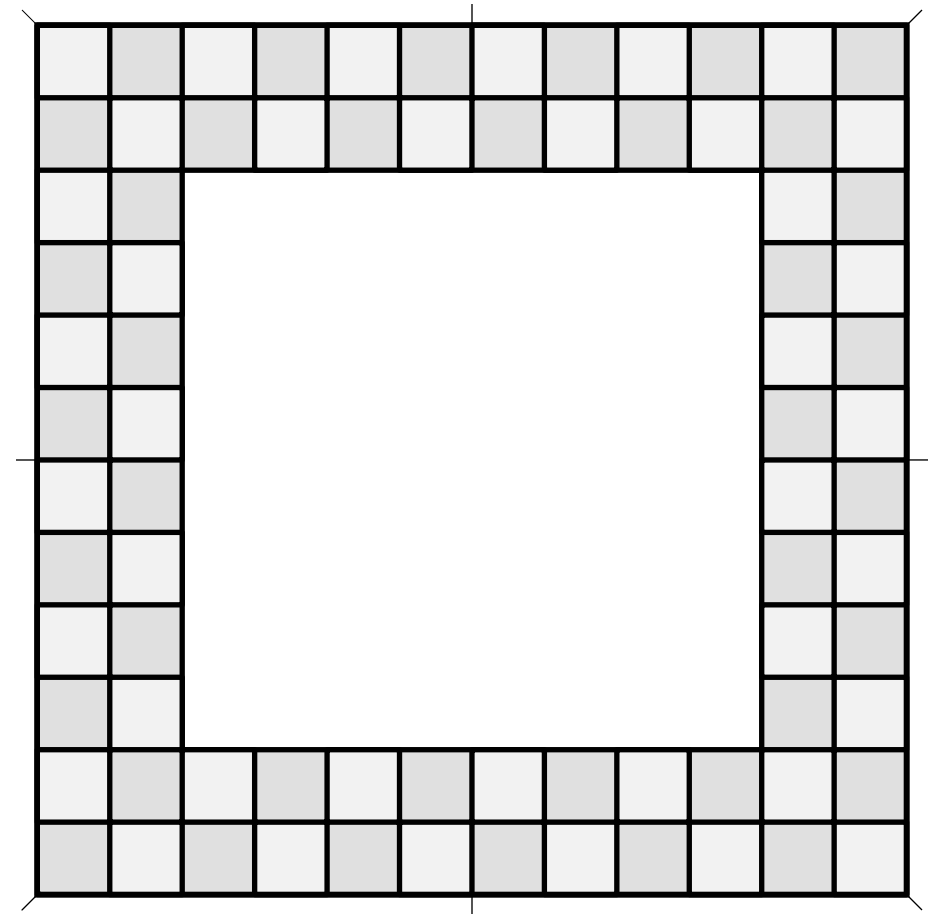
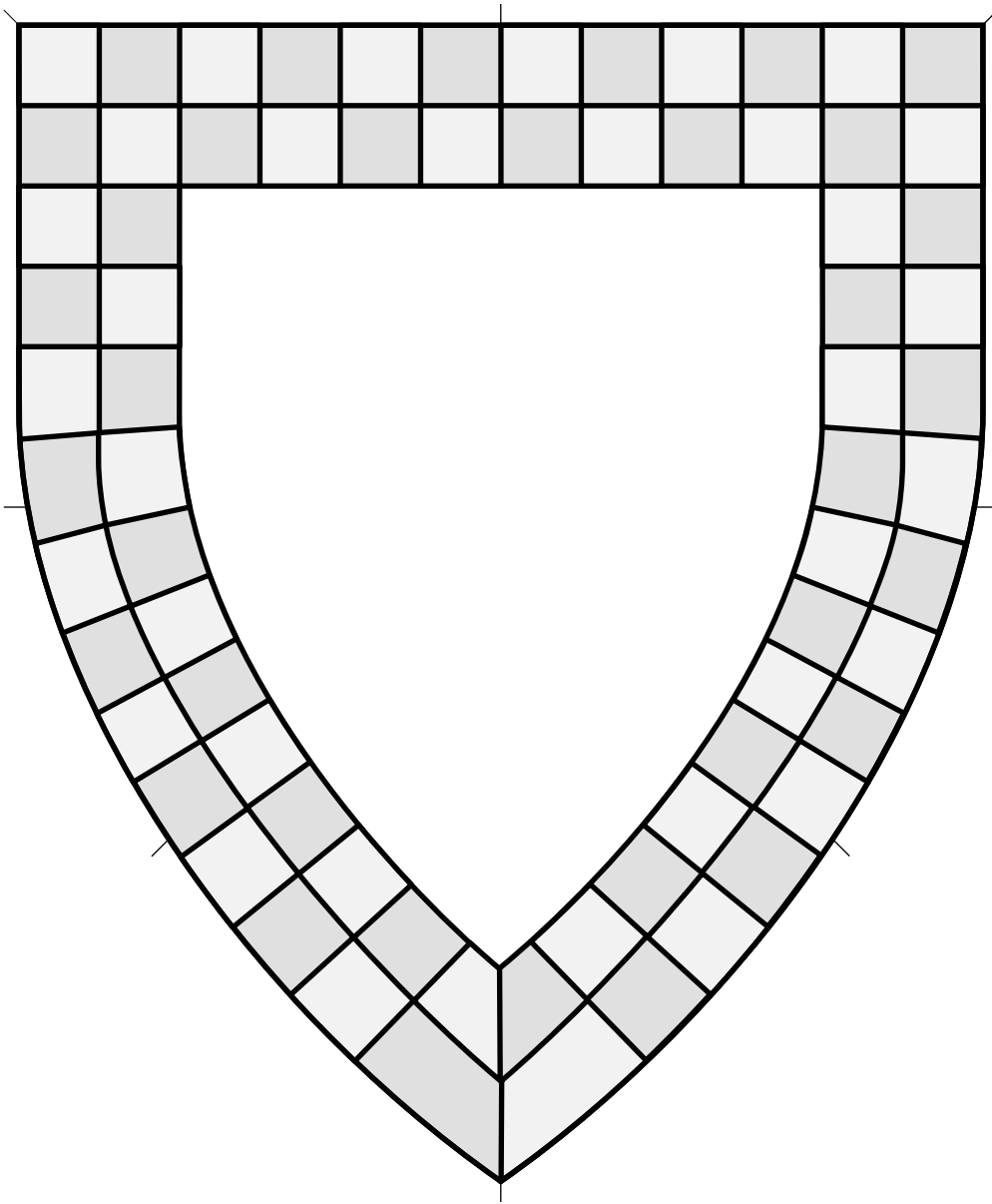

Peripheral ordinary. This bordure is separated into alternating squares of contrasting tinctures.

Bordure Counter-compony (1) 4.163

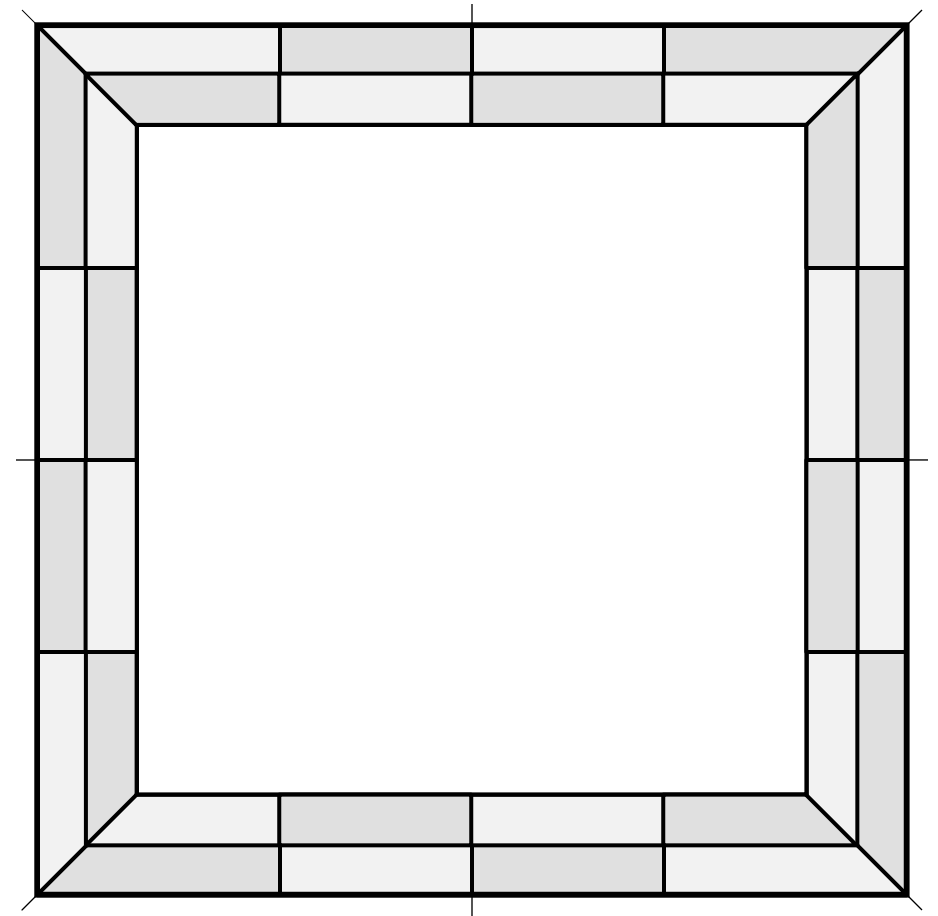
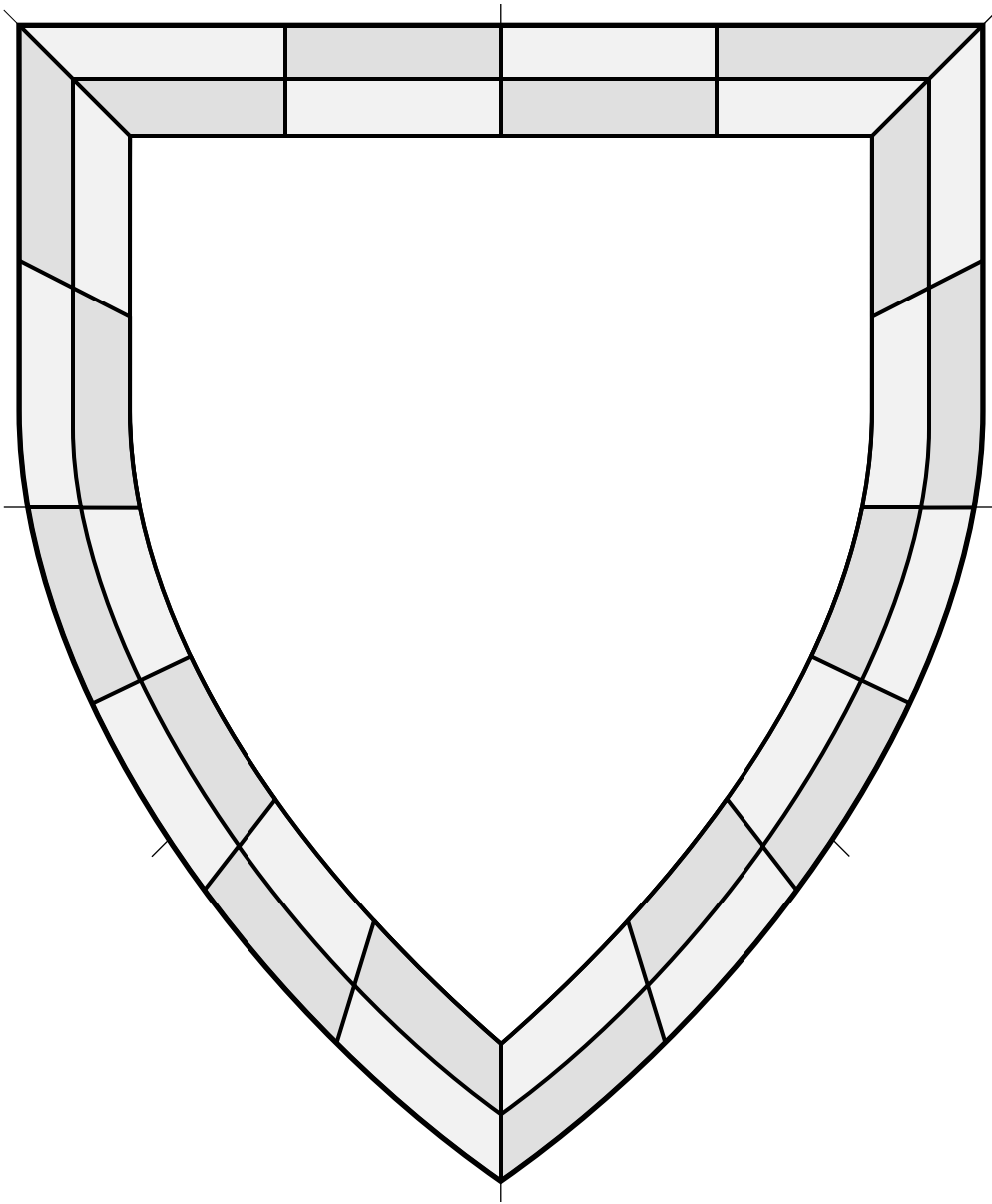

Peripheral ordinary. This bordure is separated into alternating squares of contrasting tinctures.

Bordure Counter-compony (2) 4.164

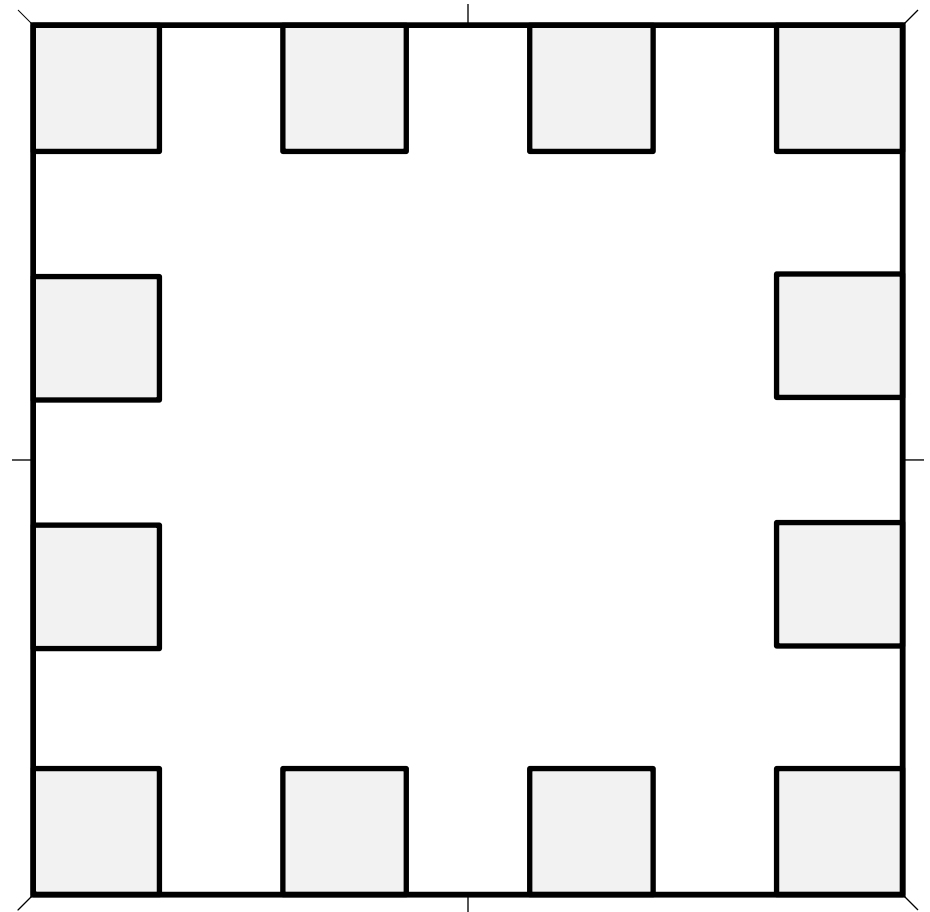
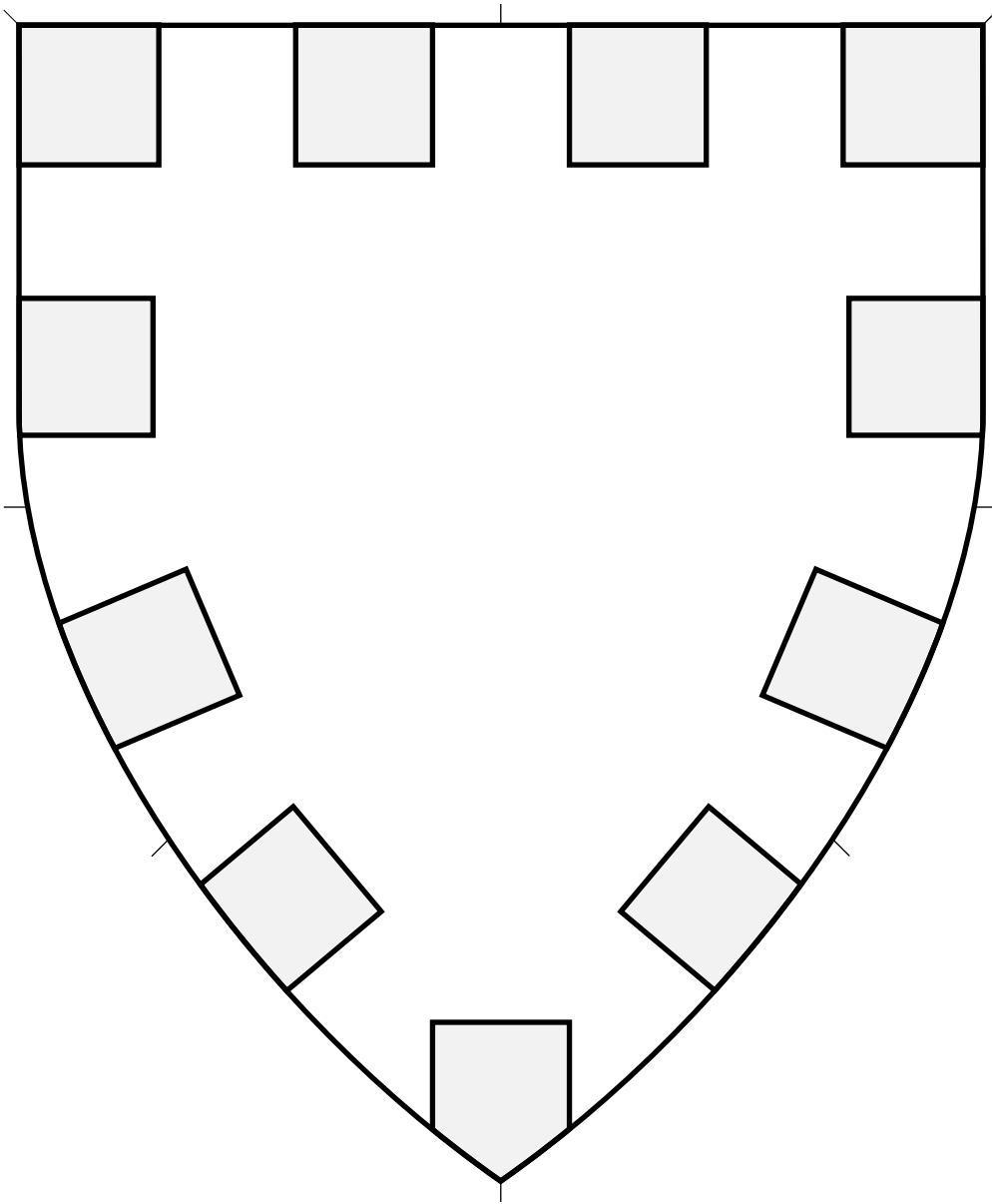

Peripheral ordinary. A bordure of "teeth," found in Iberian heraldry.
Source: Viking Answer Lady SVG Images For Heraldry.
Artist: Gunnvôr silfrahárr. Adapted by Mathghamhain Ua Ruadháin.

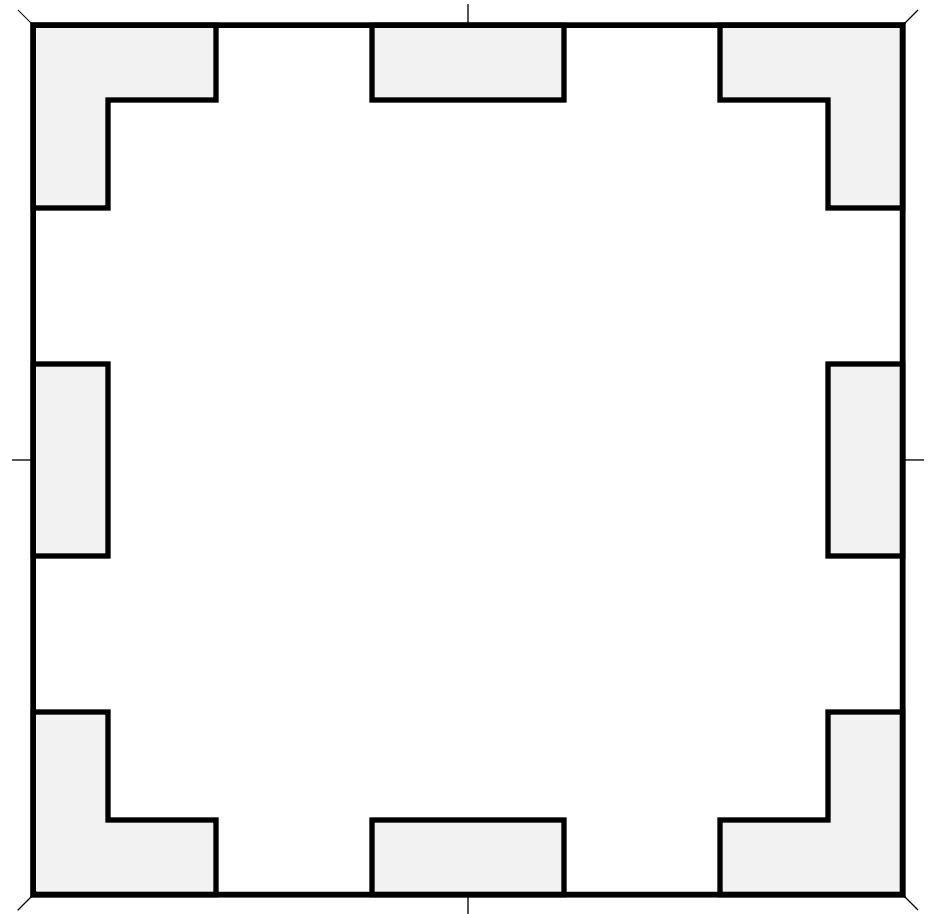
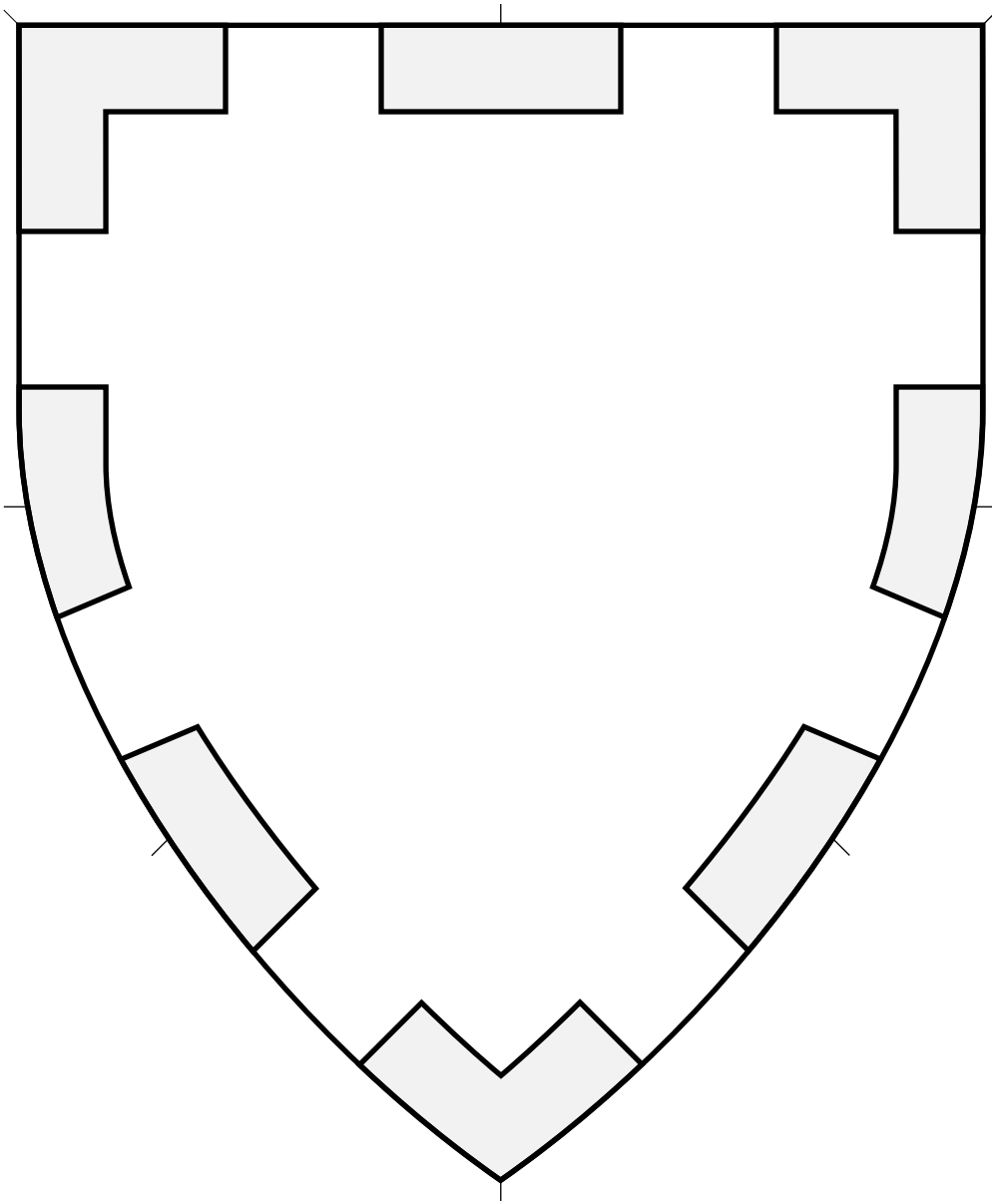

Peripheral ordinary. A bordure of "teeth," found in Iberian heraldry.
Source: Armas de los Condes. Artist unknown.
(Arms of Vesconte de Cabrera.)

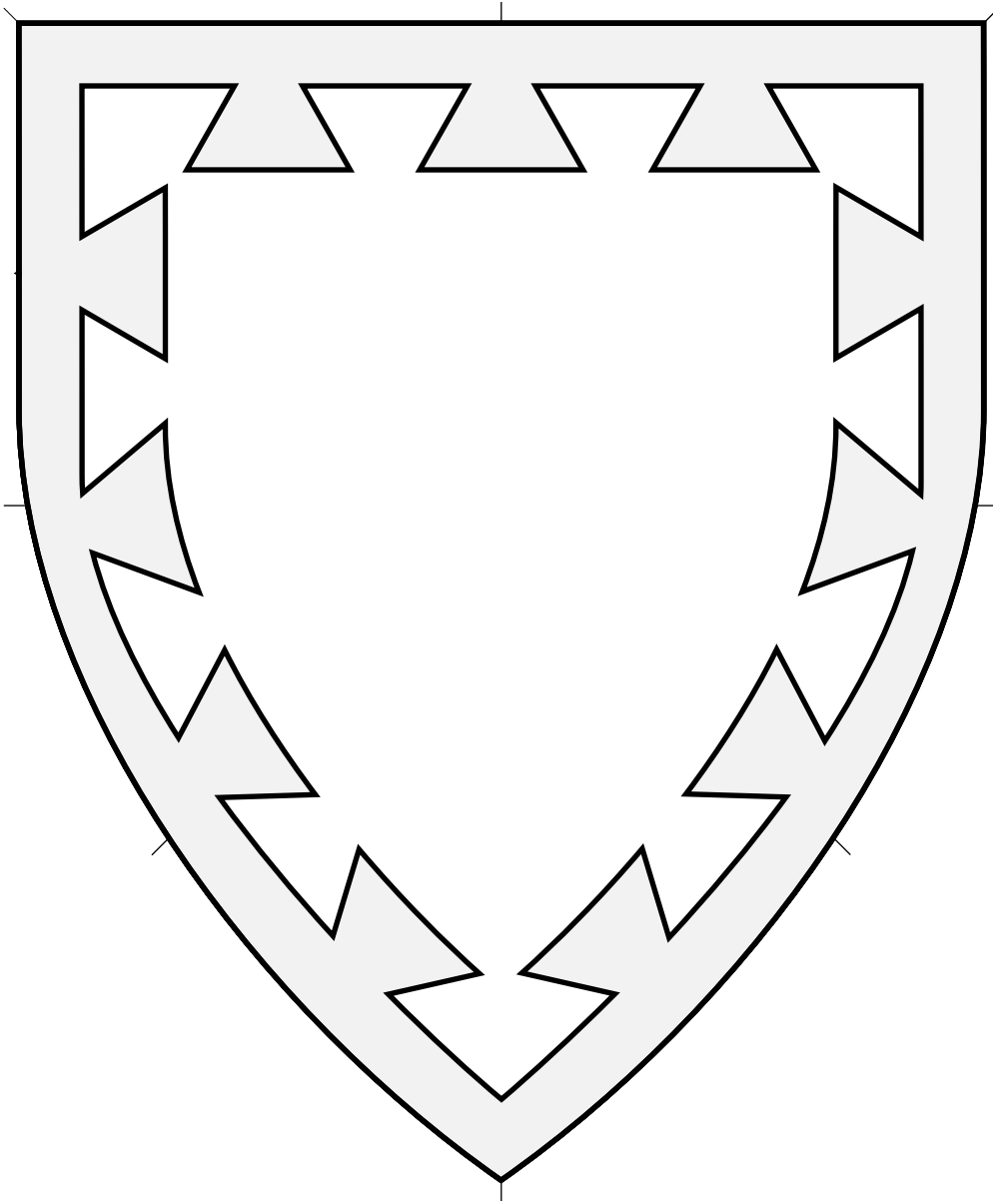

Peripheral ordinary.

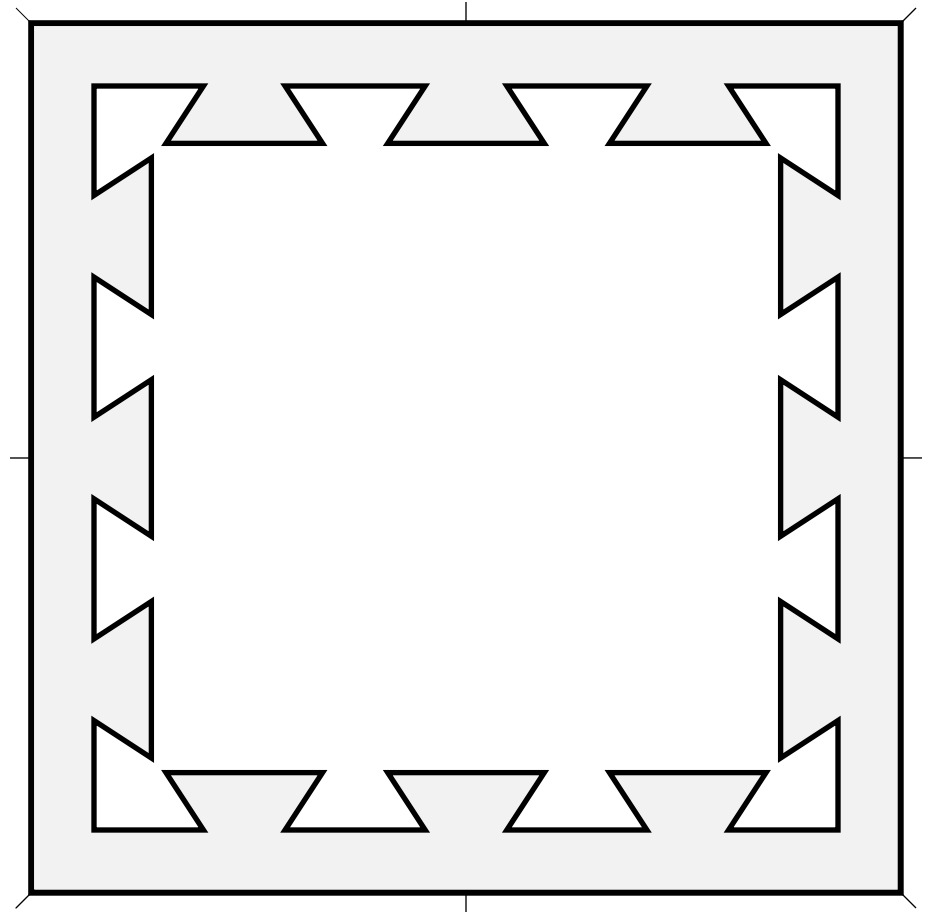

Bordure Dovetailed 4.167

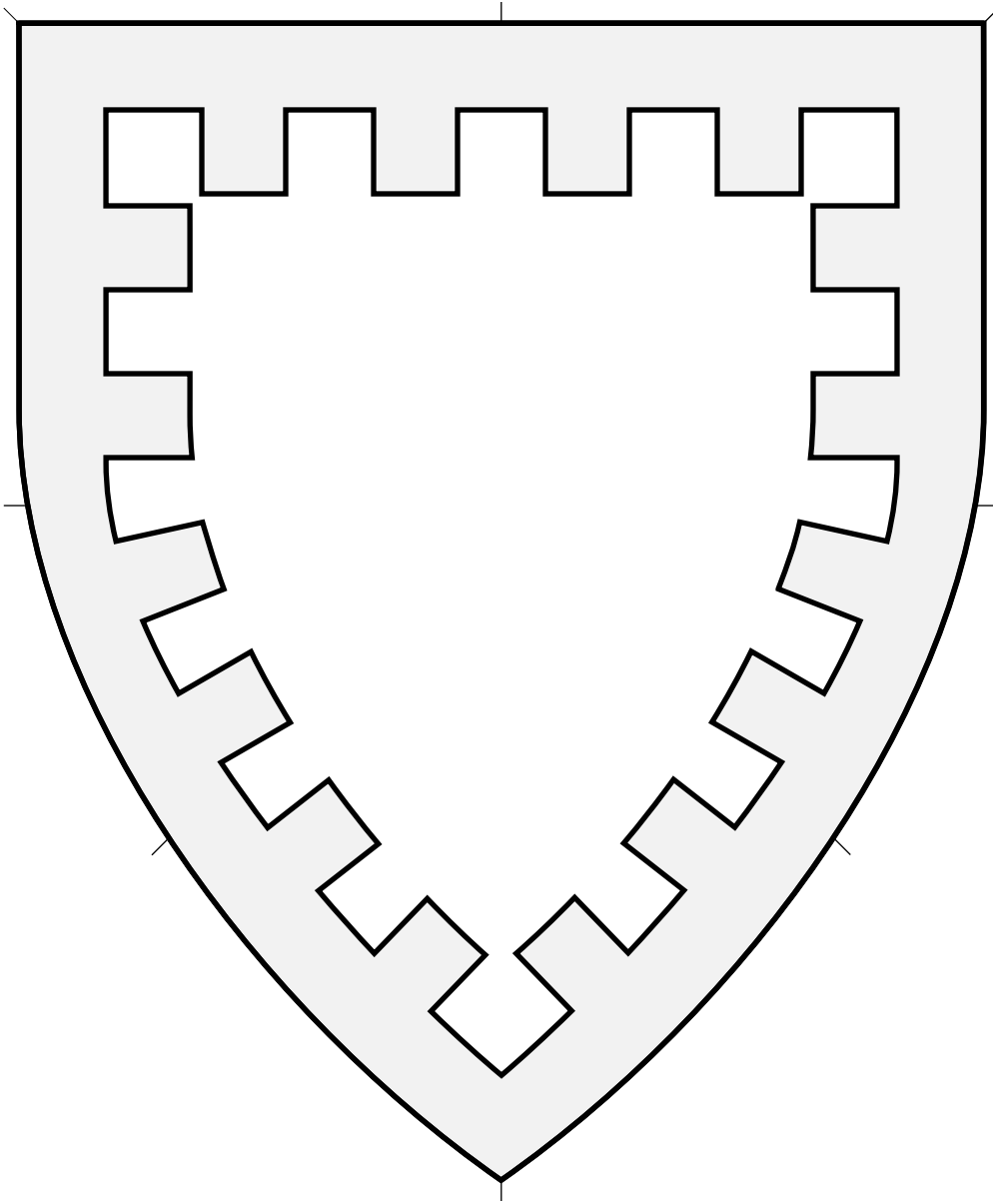

Peripheral ordinary.

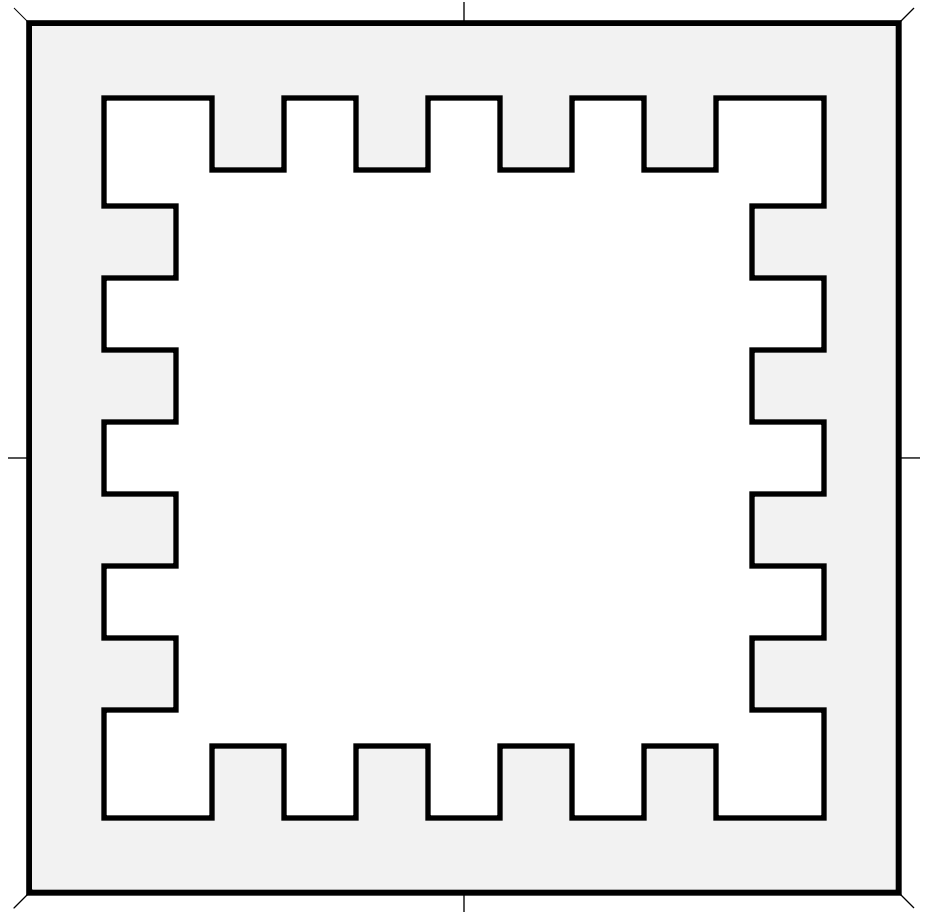

Bordure Embattled (1) 4.168

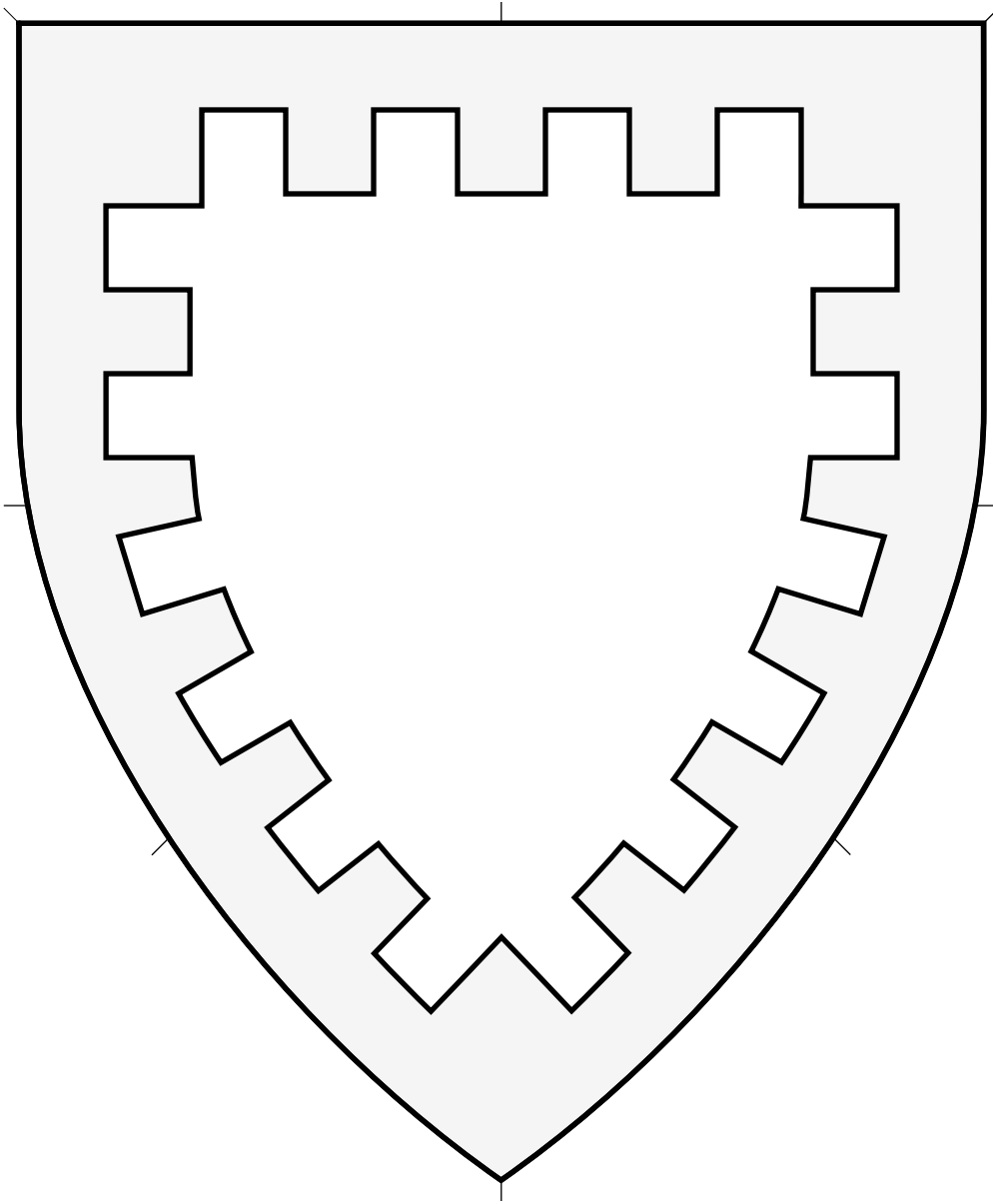

Peripheral ordinary.

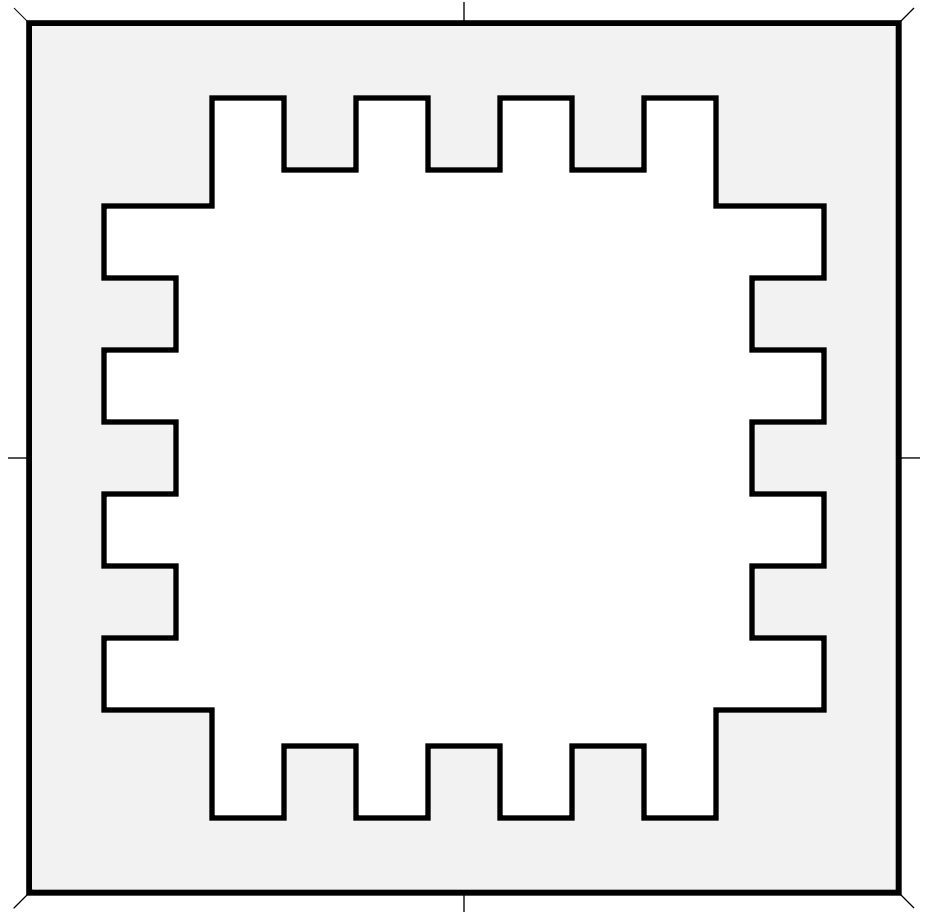

Bordure Embattled (2) 4.169

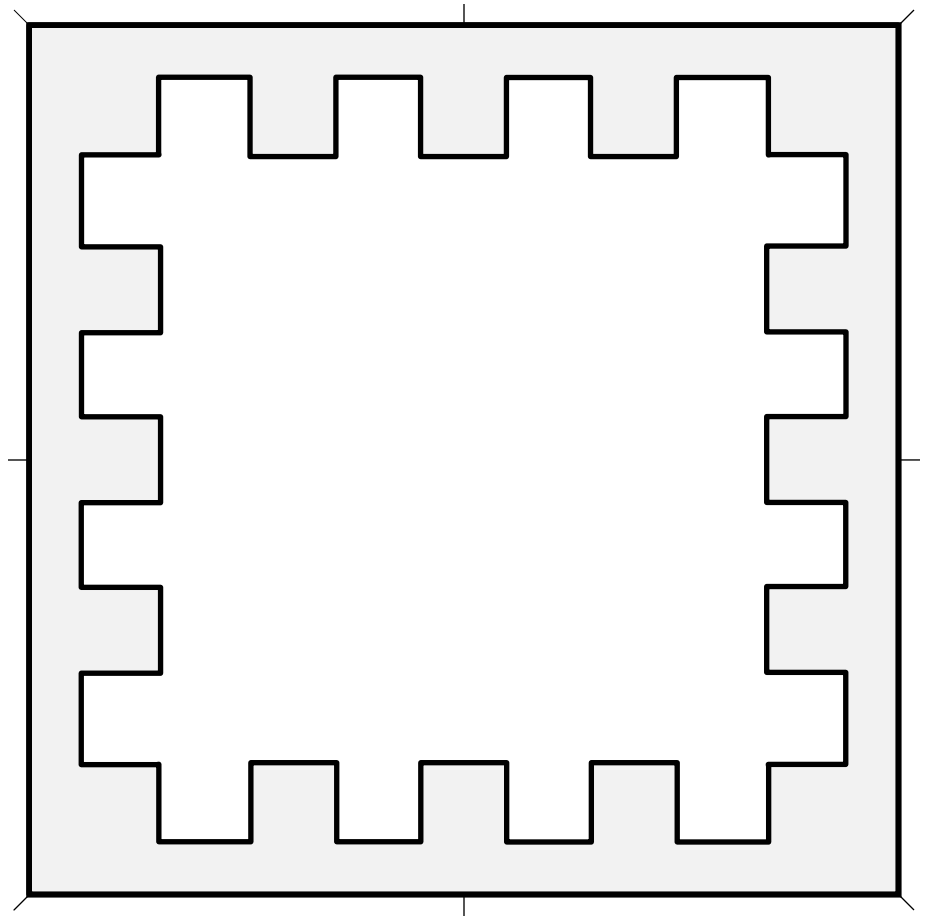
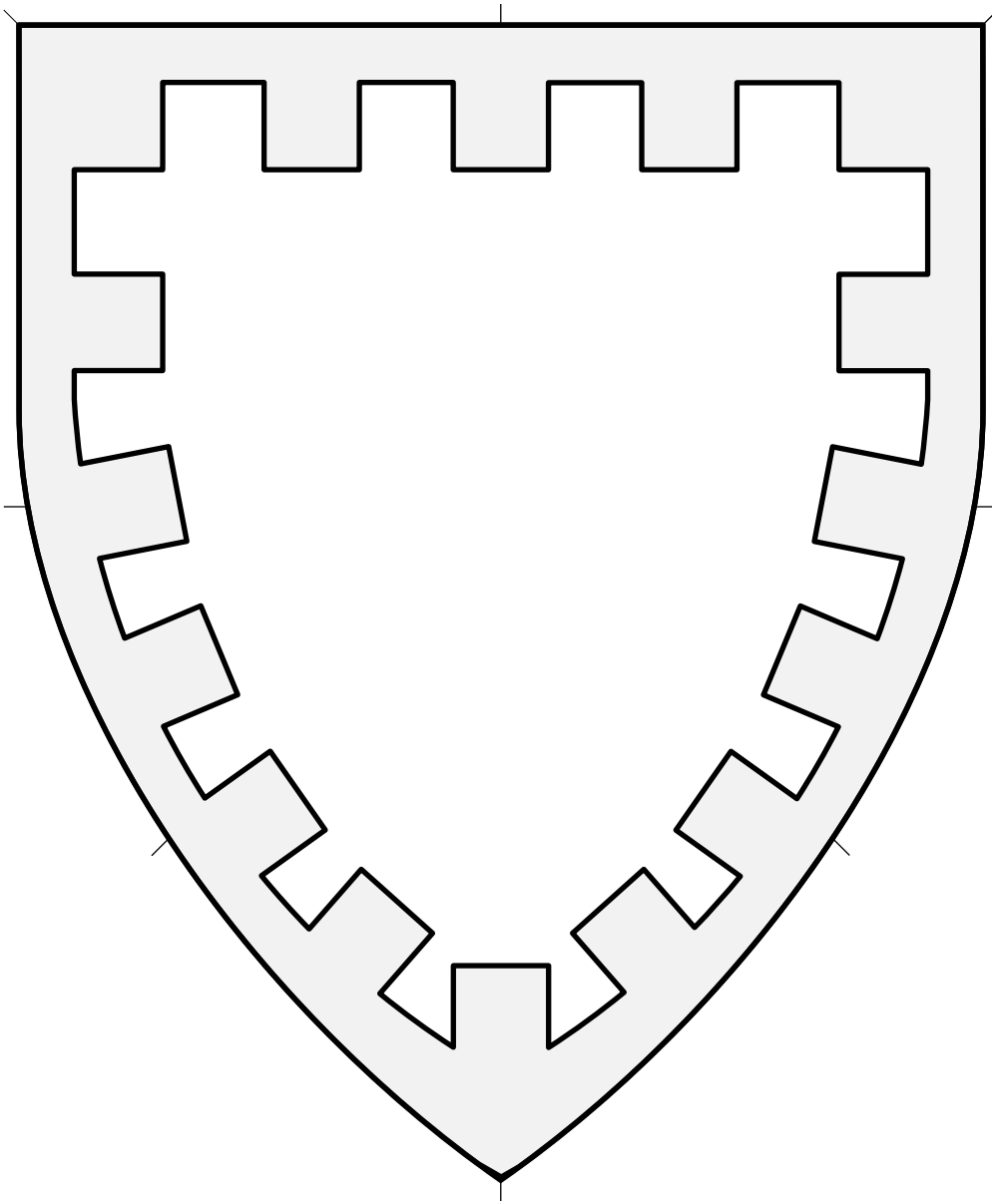

Peripheral ordinary.

Source: Viking Answer Lady SVG Images For Heraldry.
Artist: Gunnvôr silfrahárr. Adapted by Mathghamhain Ua Ruadháin.

Bordure Embattled (3) 4.170

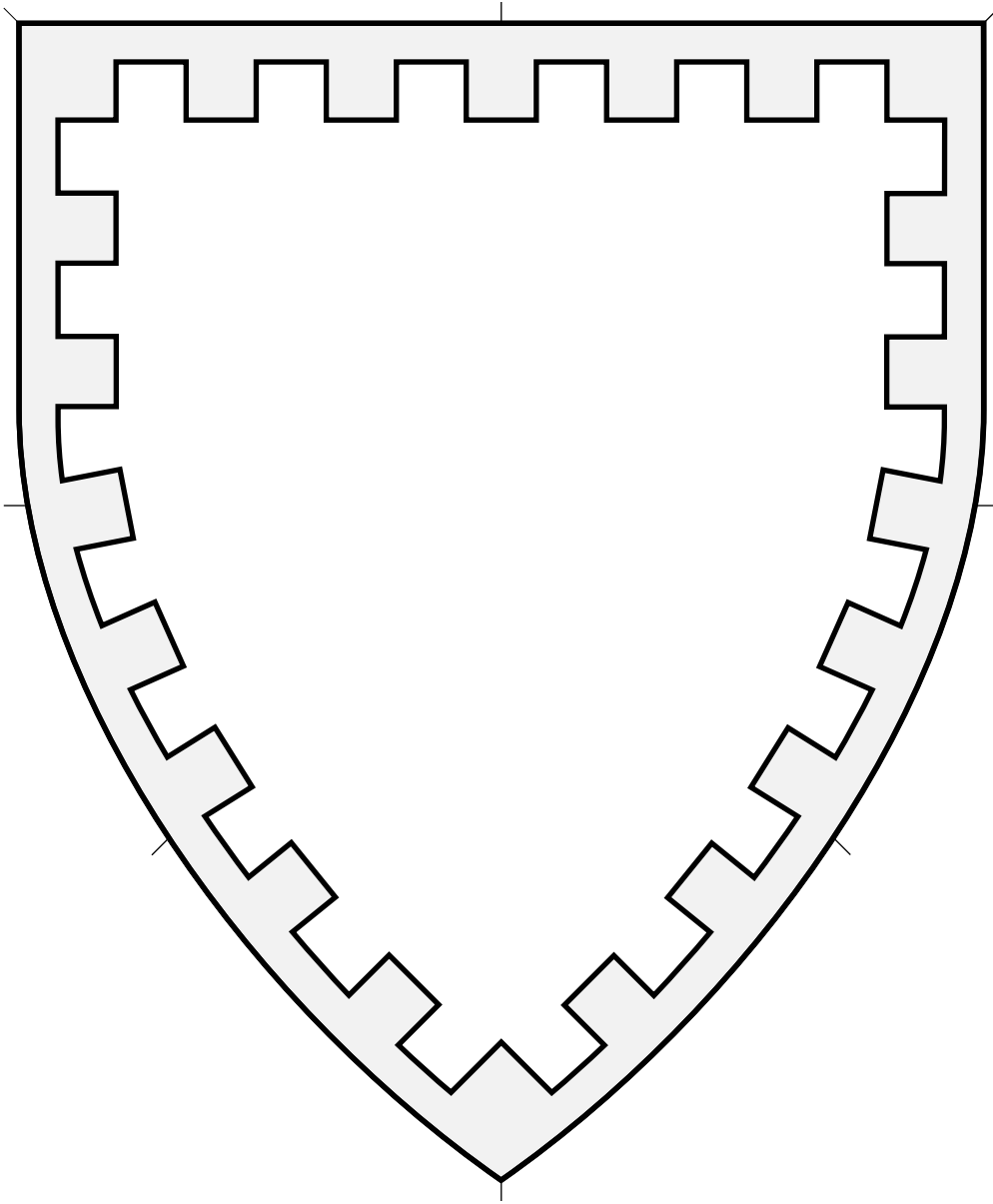

Peripheral ordinary.

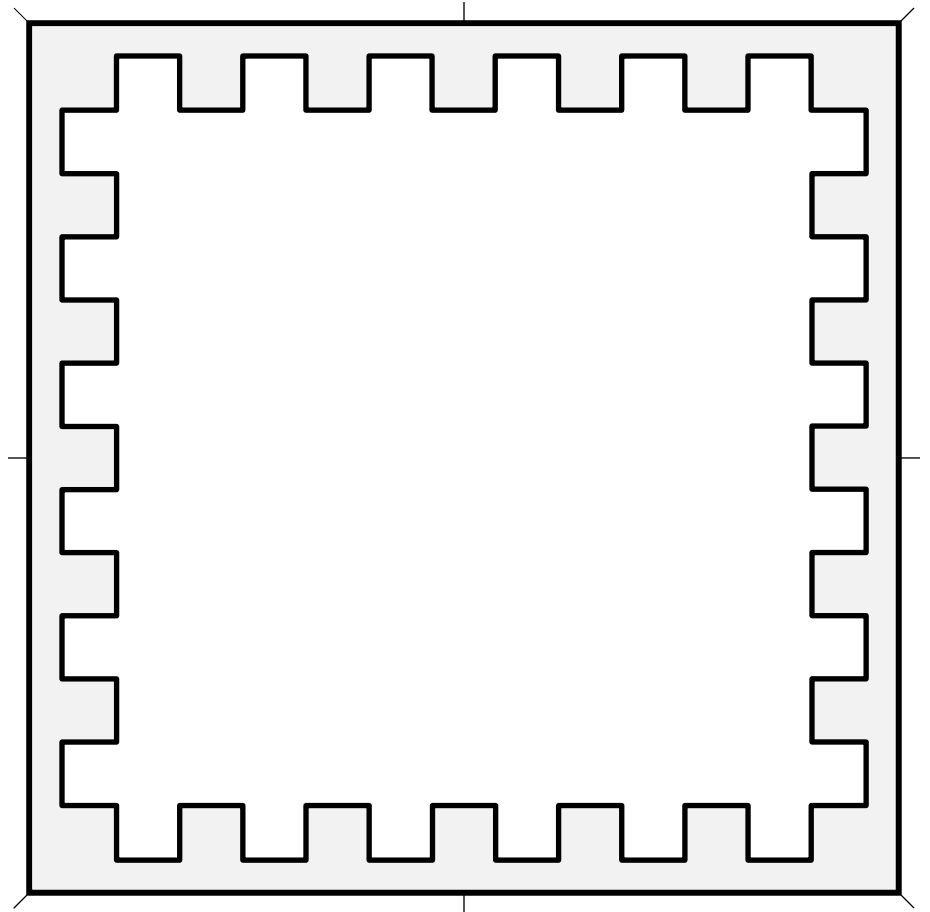

Bordure Embattled (4) 4.171

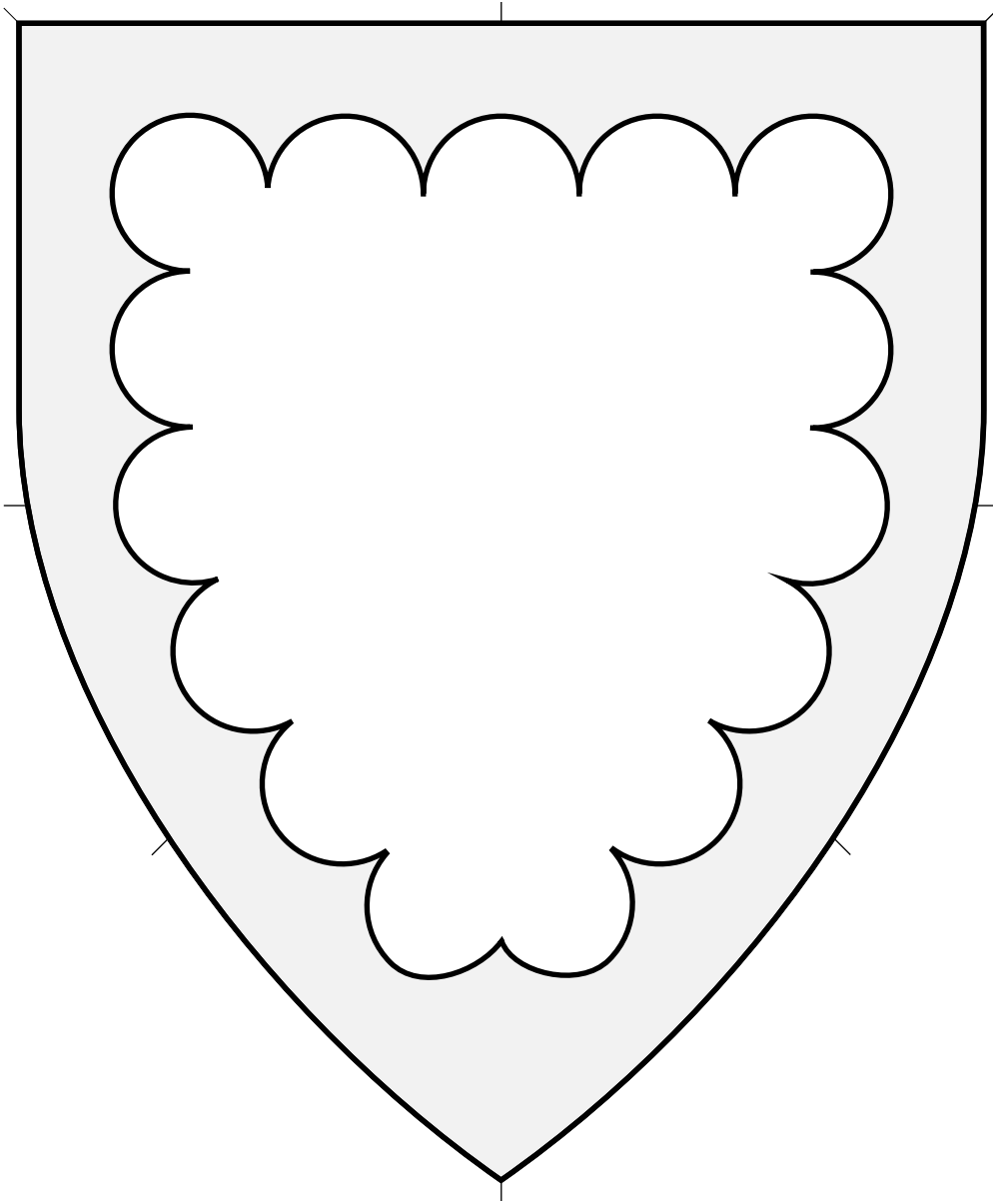

Peripheral ordinary.

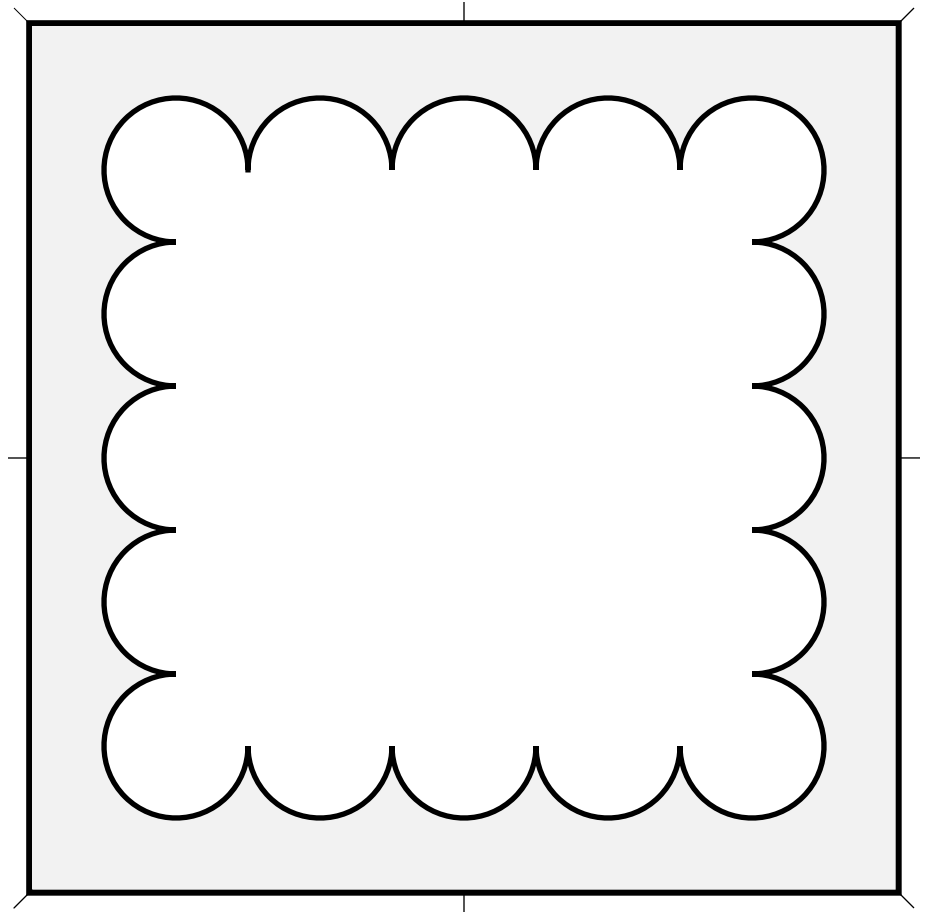

Bordure Engrailed (1) 4.172

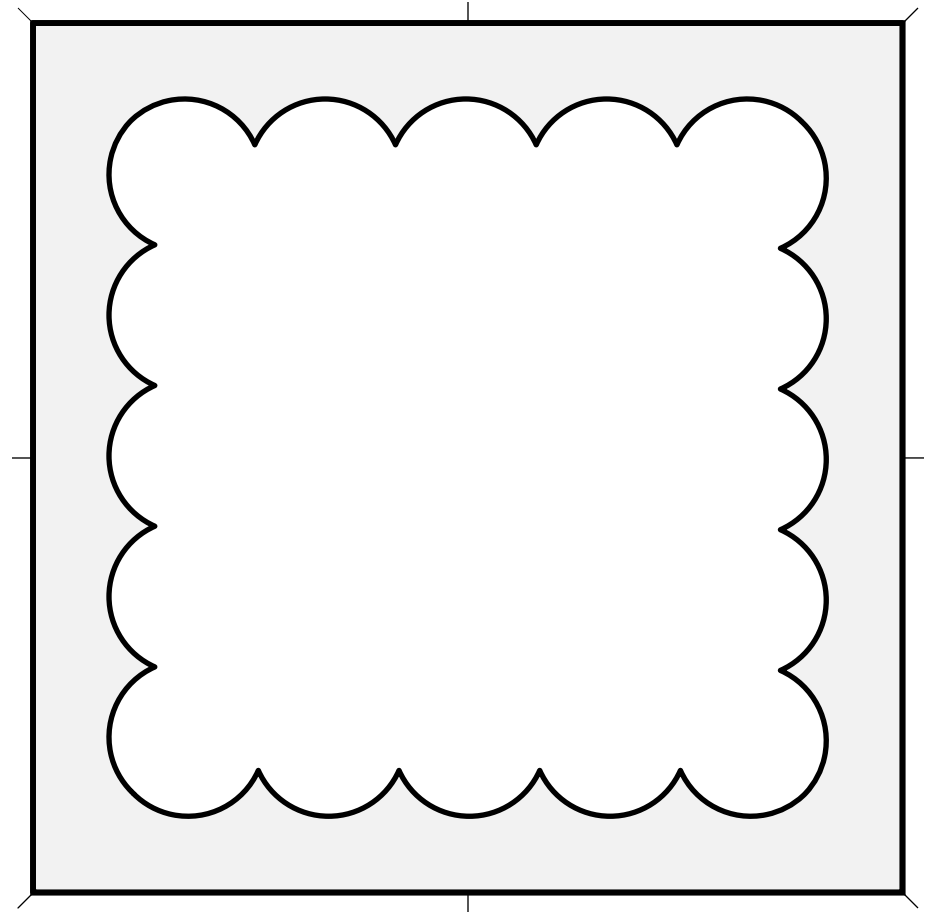
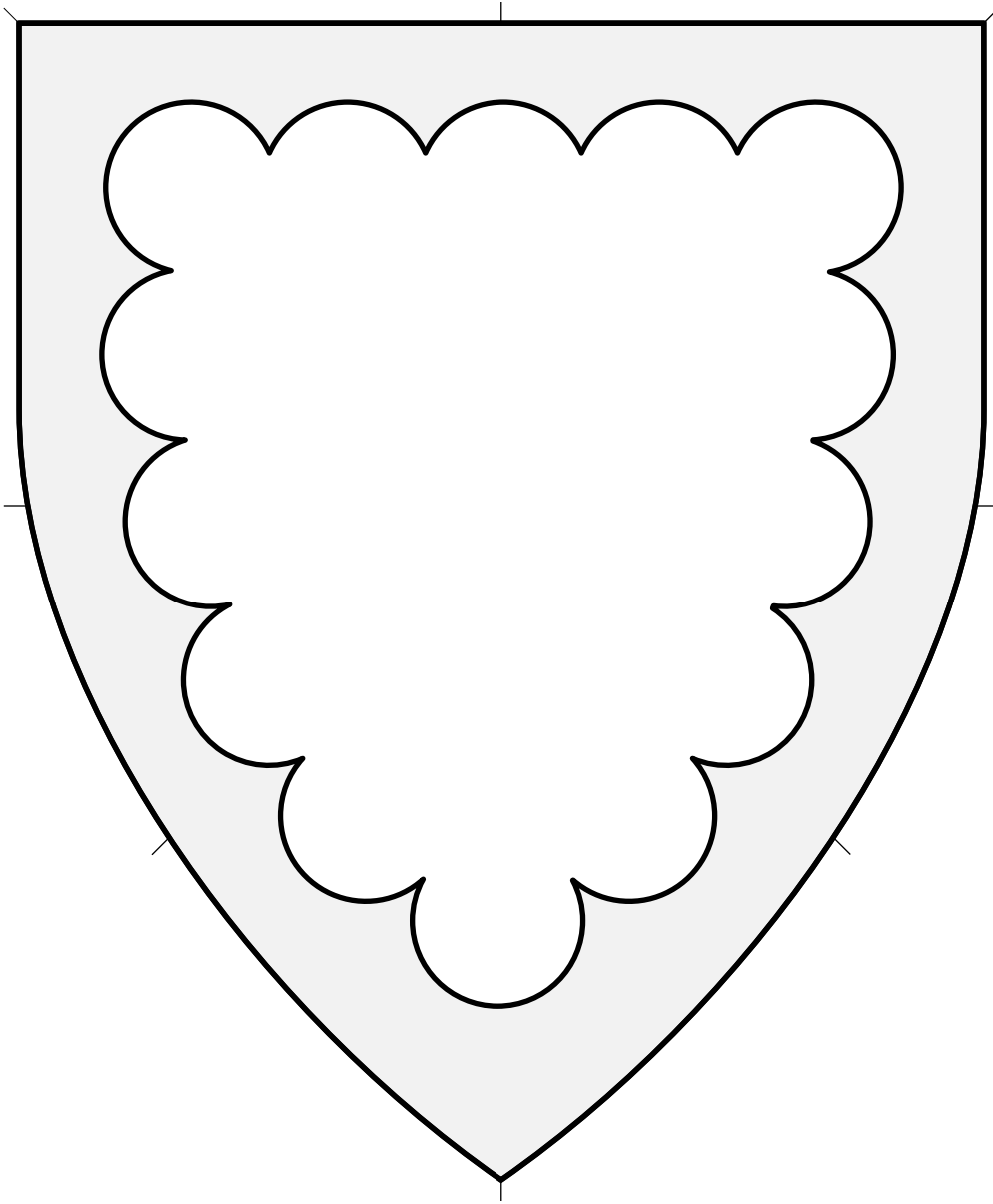

Peripheral ordinary.

Source: Viking Answer Lady SVG Images For Heraldry.
Artist: Gunnvôr silfrahárr. Adapted by Mathghamhain Ua Ruadháin.

Bordure Engrailed (2) 4.173

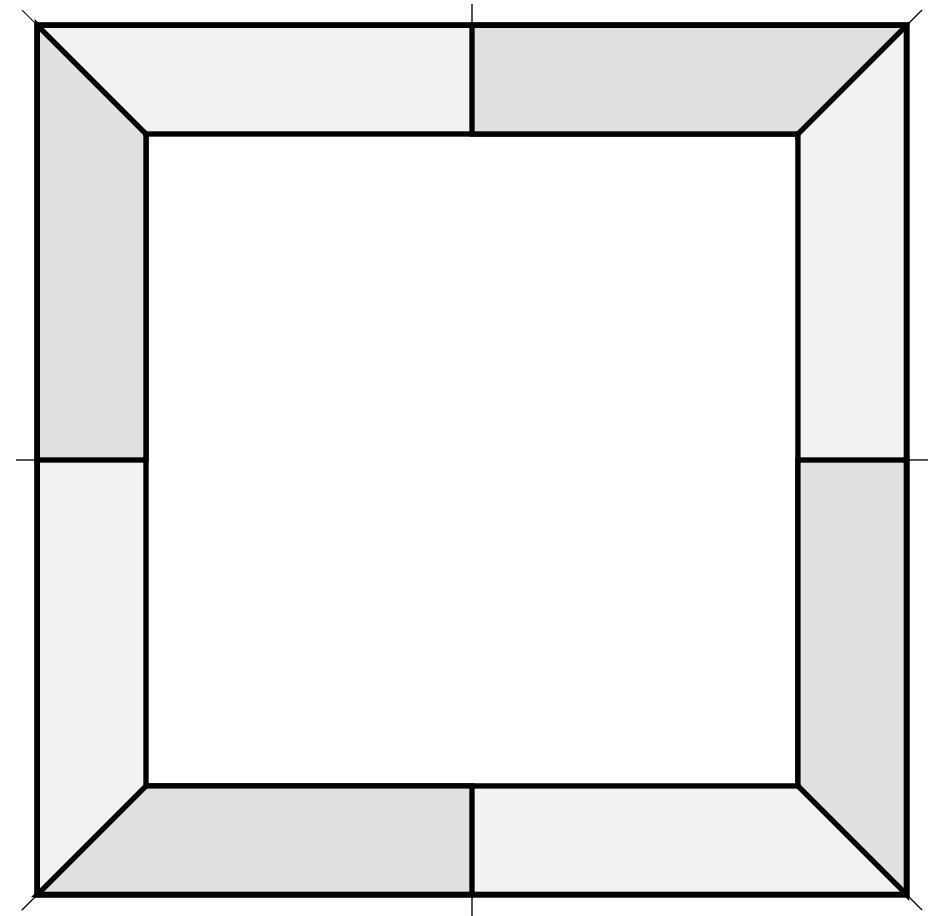
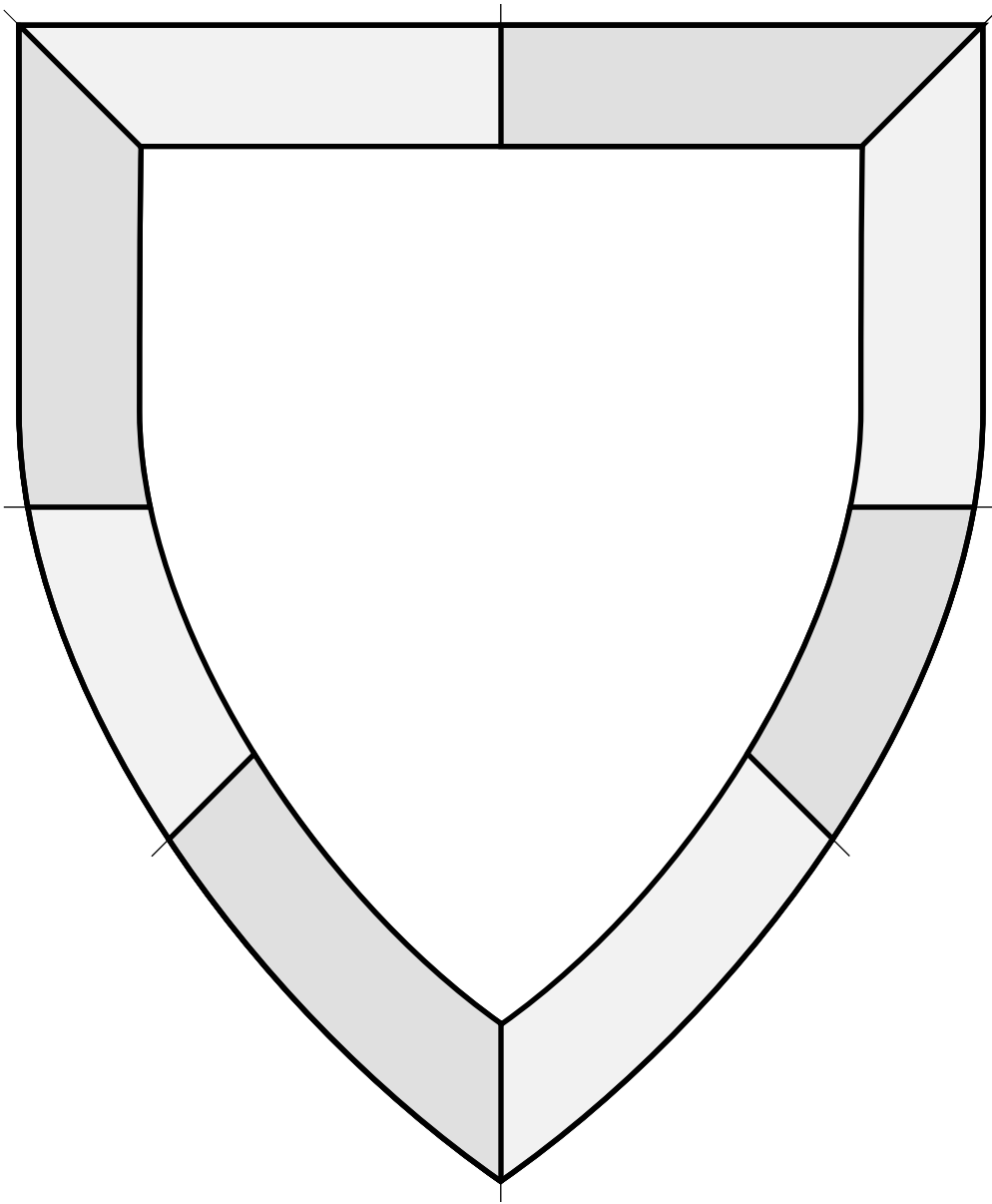

Peripheral ordinary. This bordure is separated into eight equally-sized segments of contrasting tinctures.

Bordure Gyronny 4.174

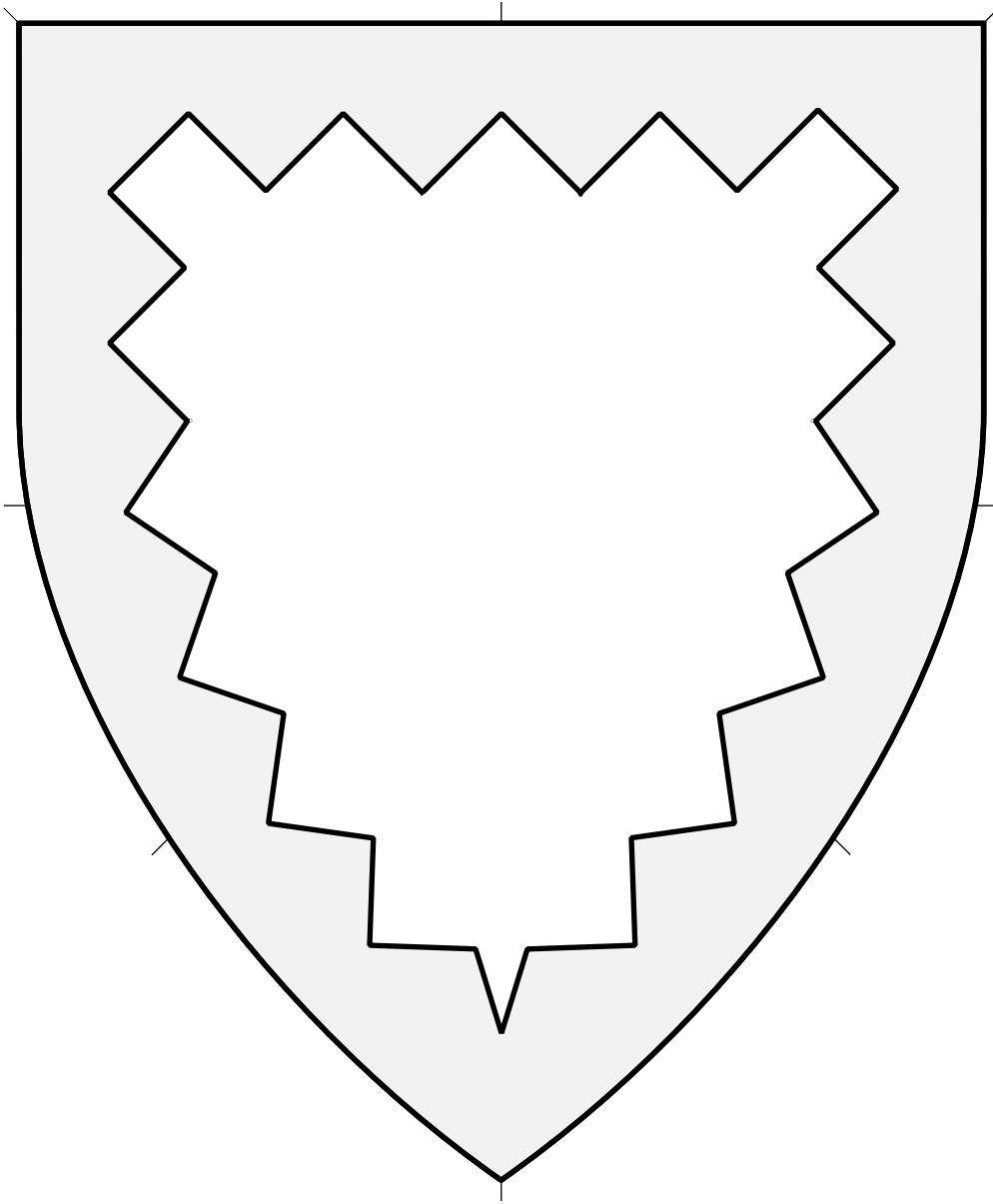

Peripheral ordinary.

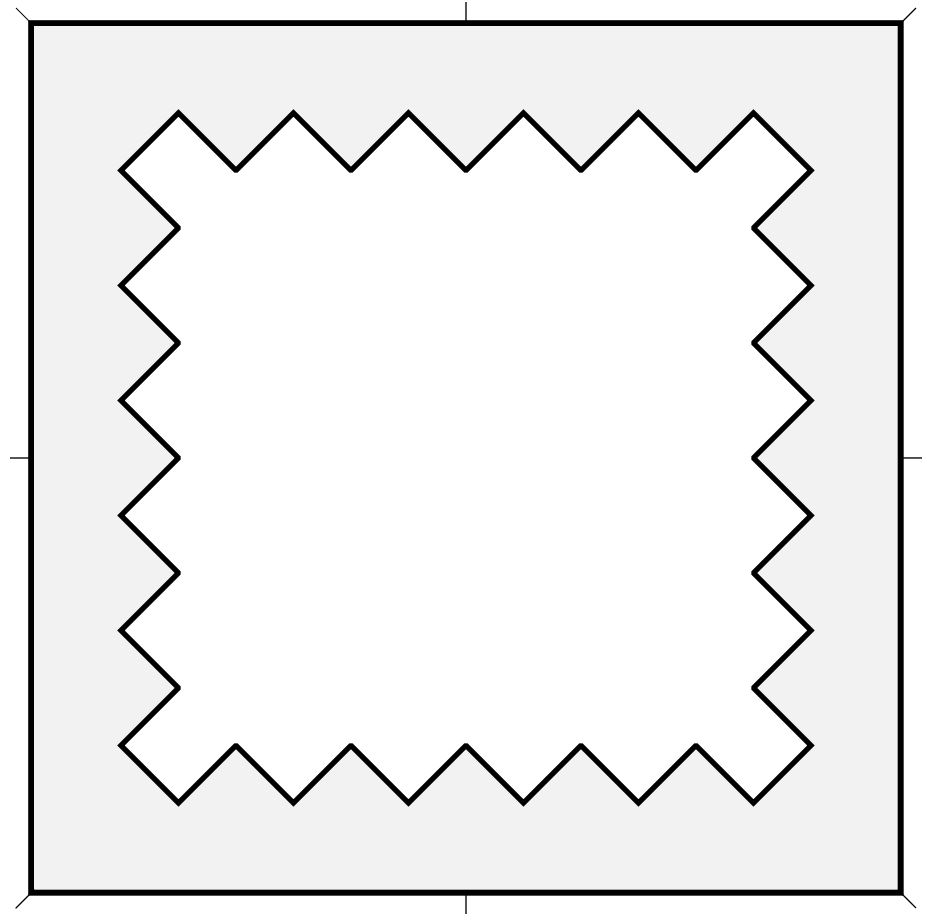

Bordure Indented 4.175

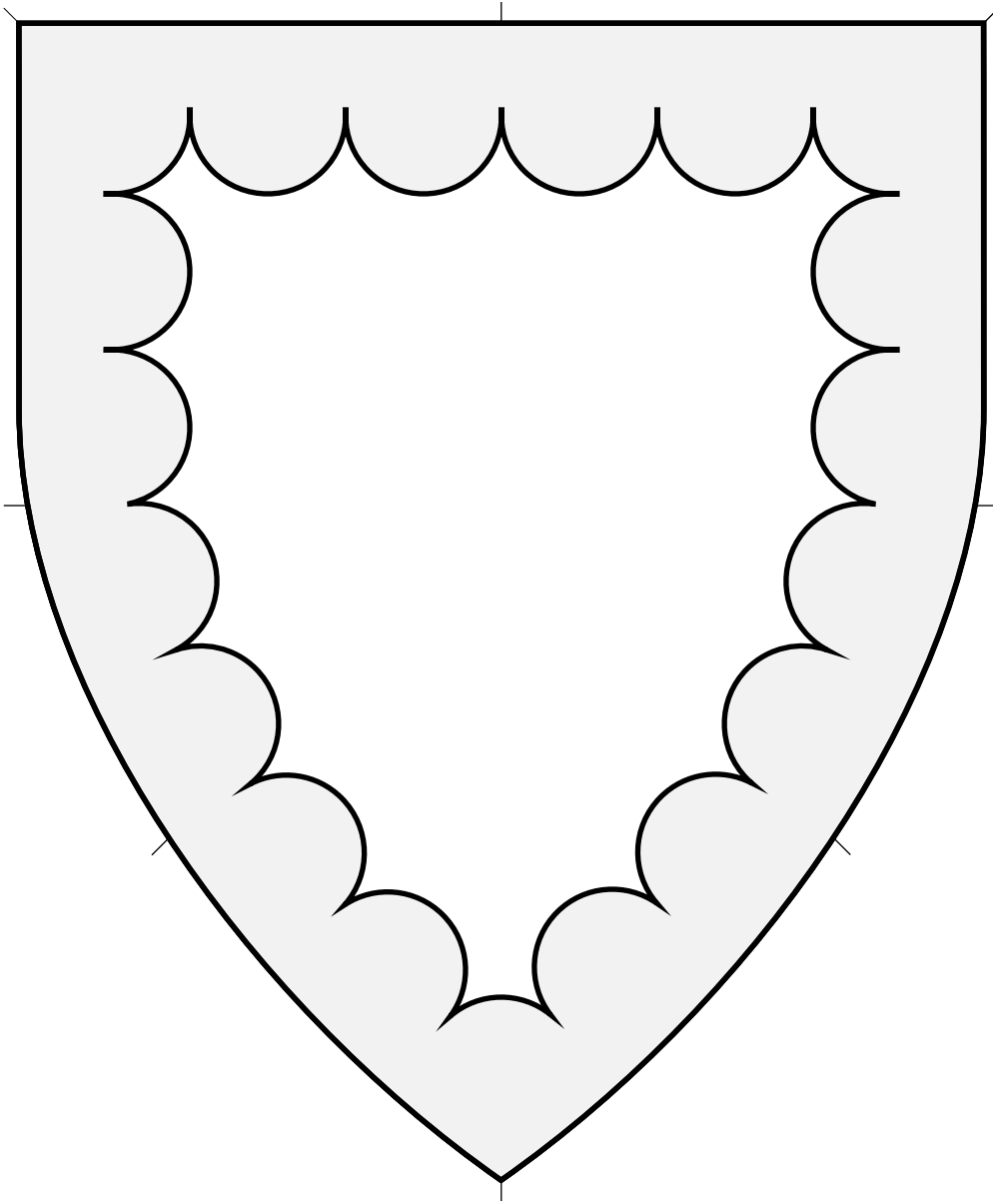

Peripheral ordinary.

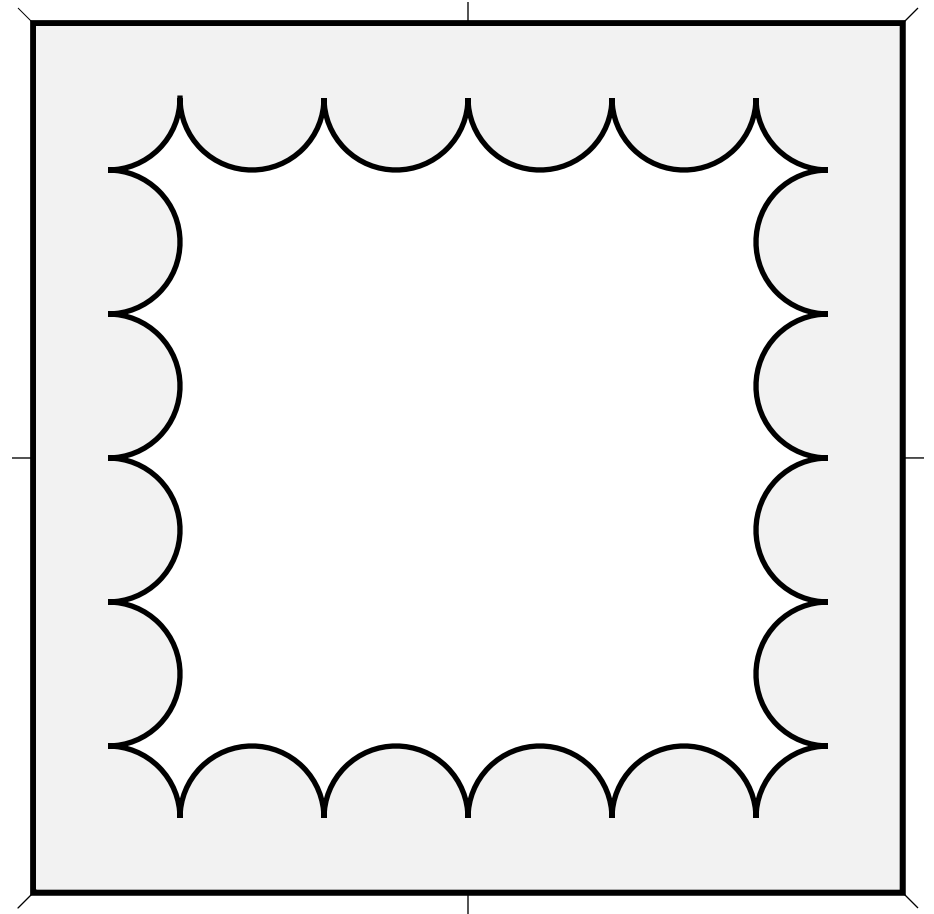

Bordure Invected (1) 4.176

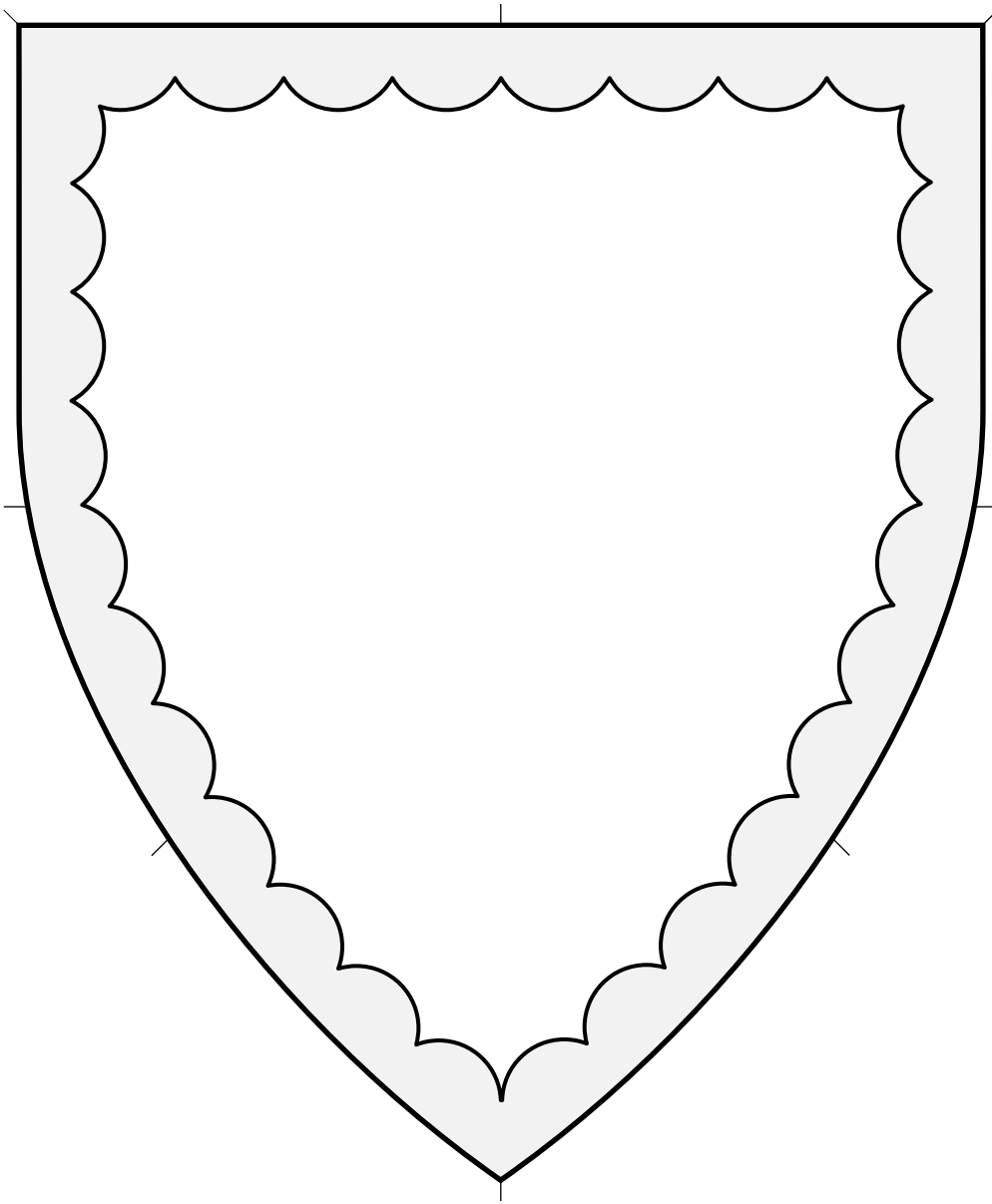

Peripheral ordinary.

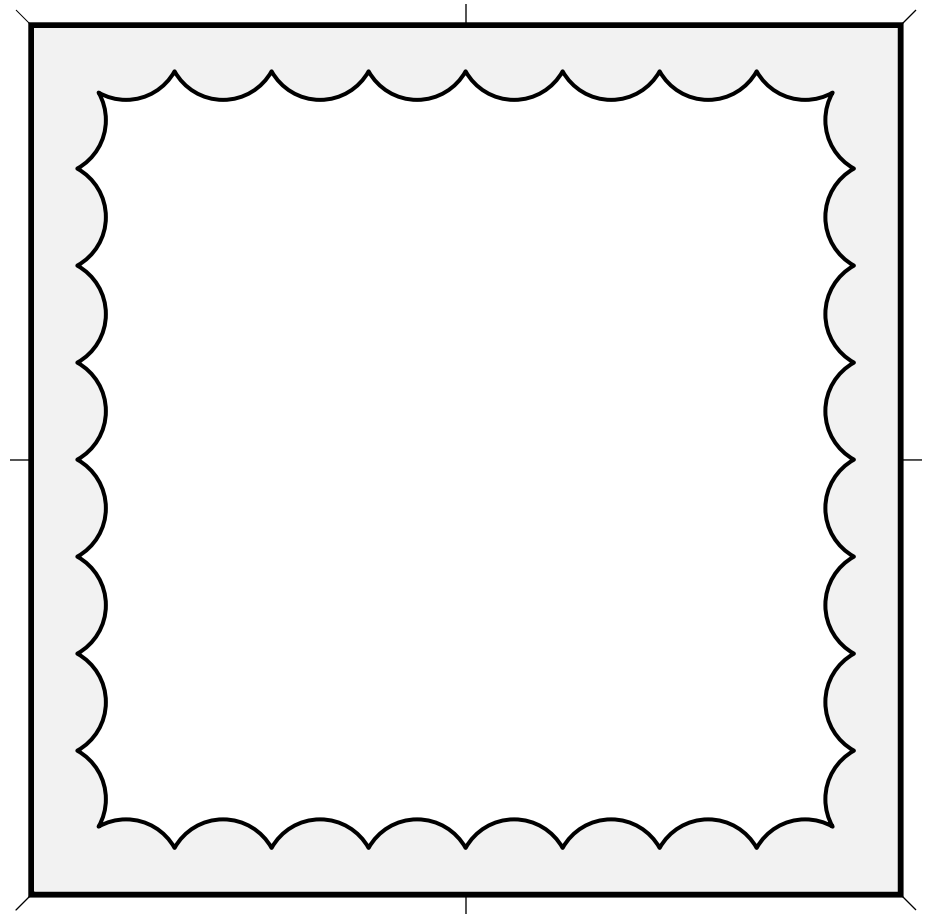

Bordure Invected (2) 4.177

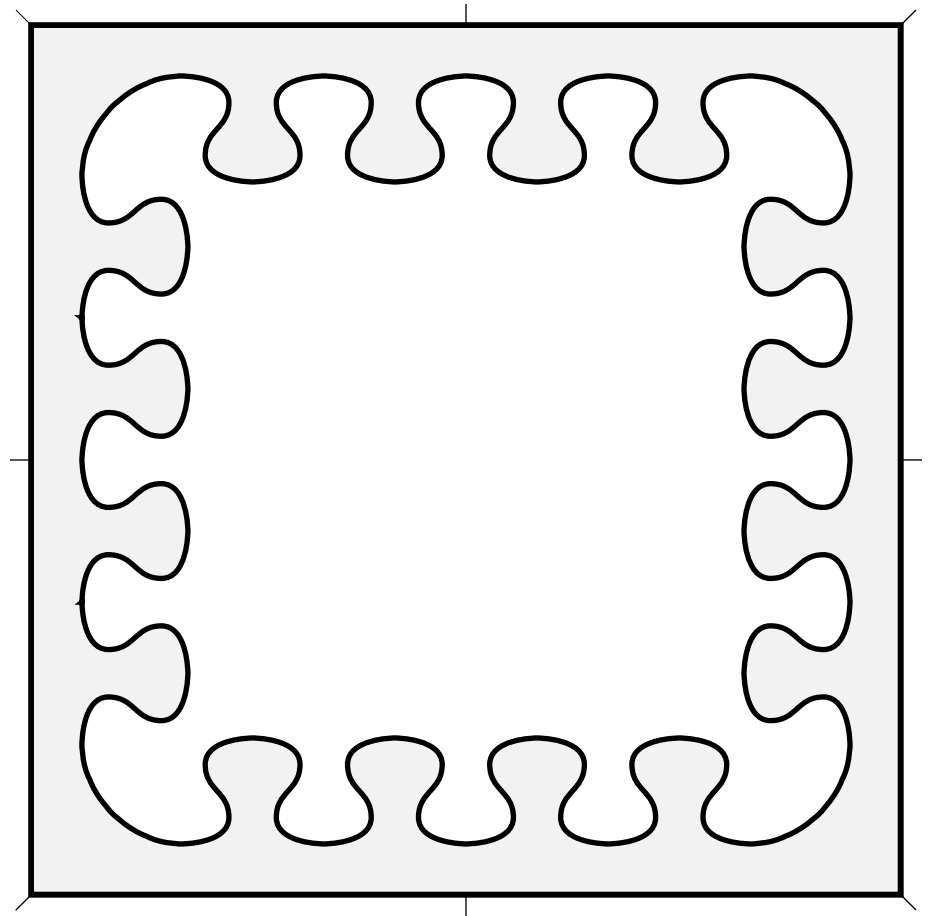
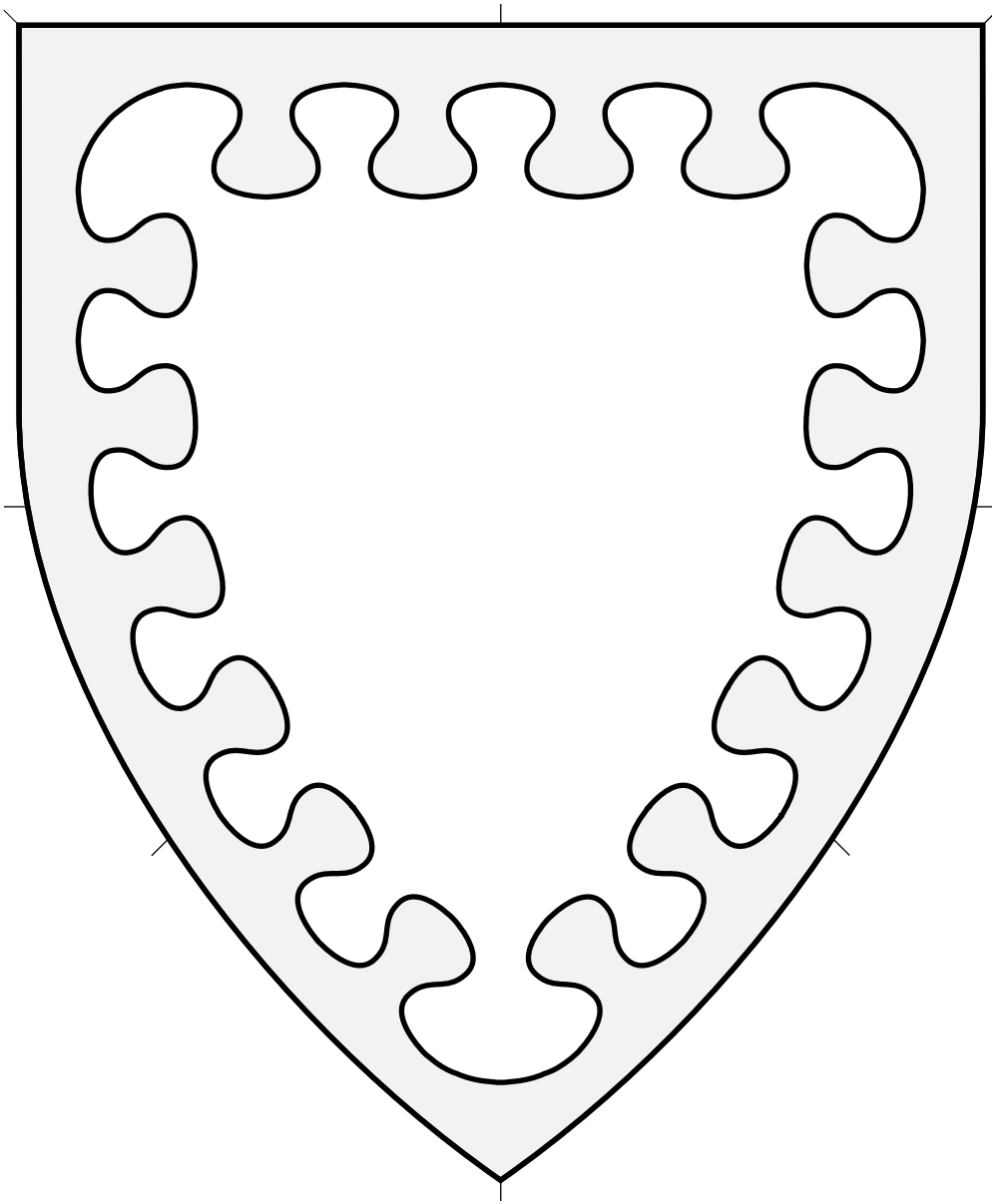

Peripheral ordinary.

Bordure Nebuly 4.178

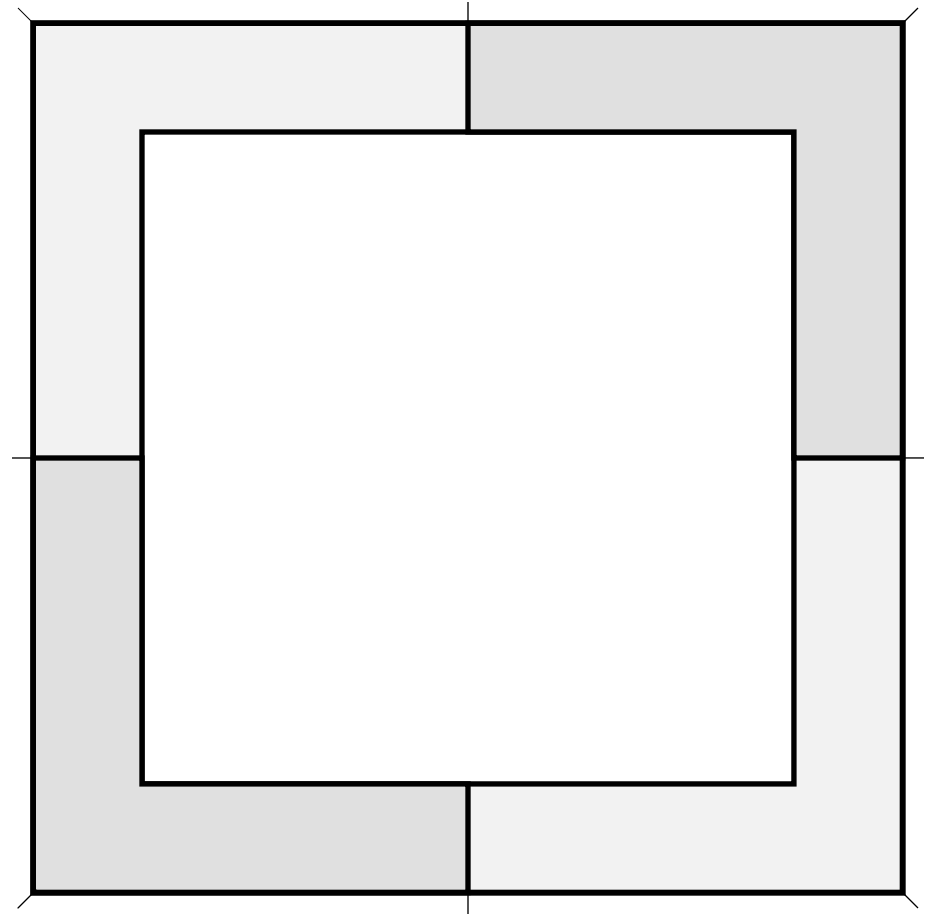
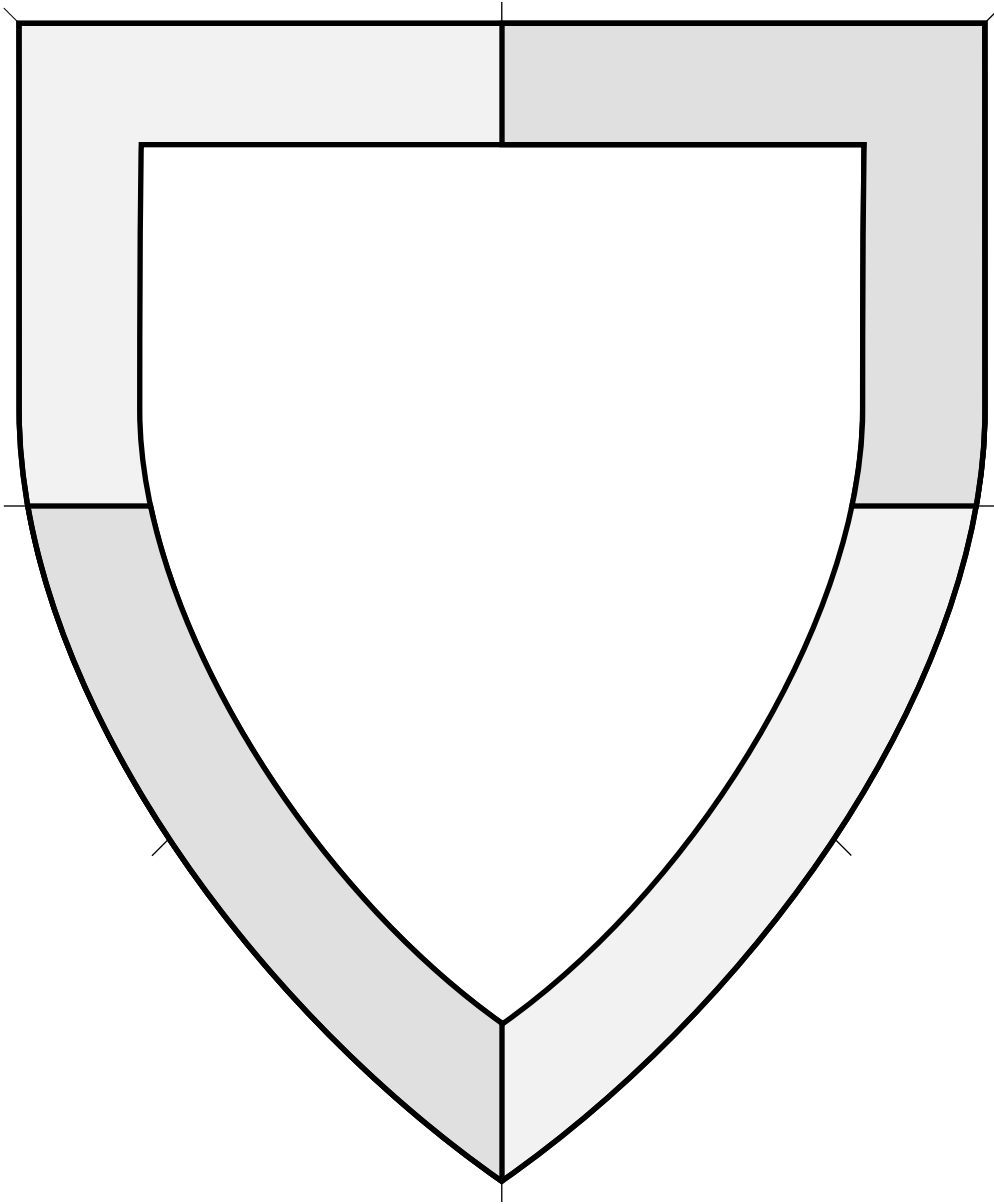

Peripheral ordinary. This bordure is separated into four equally-sized segments of contrasting tinctures.

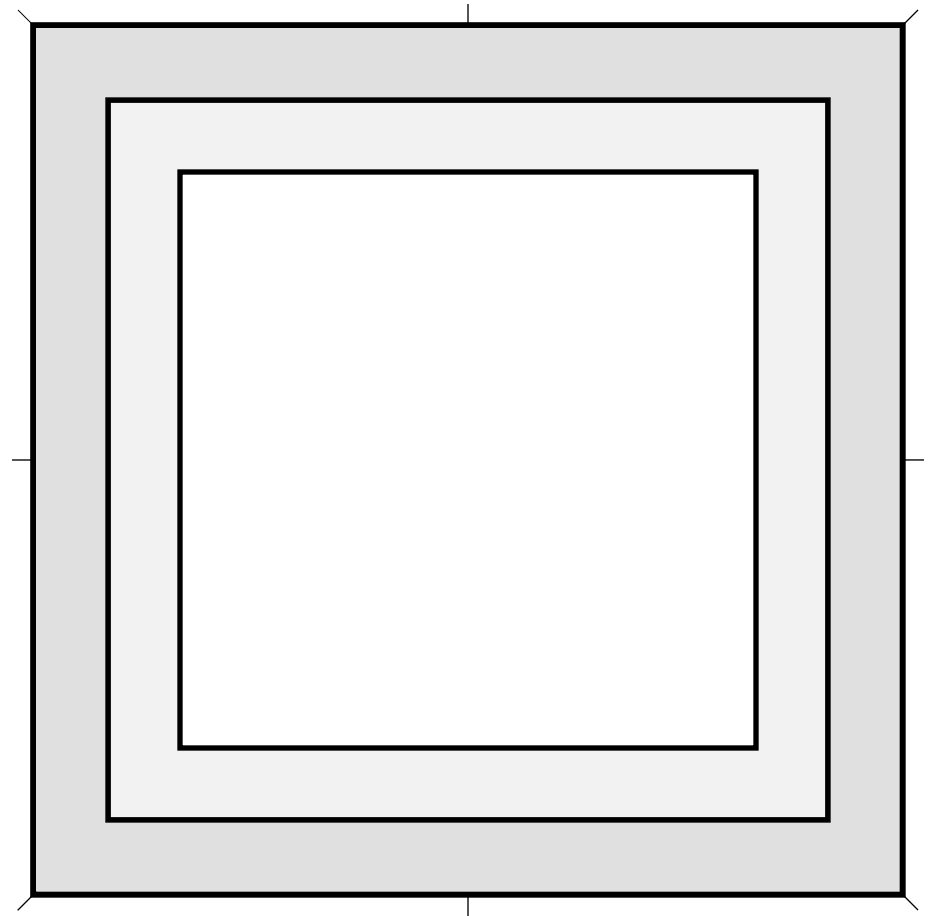
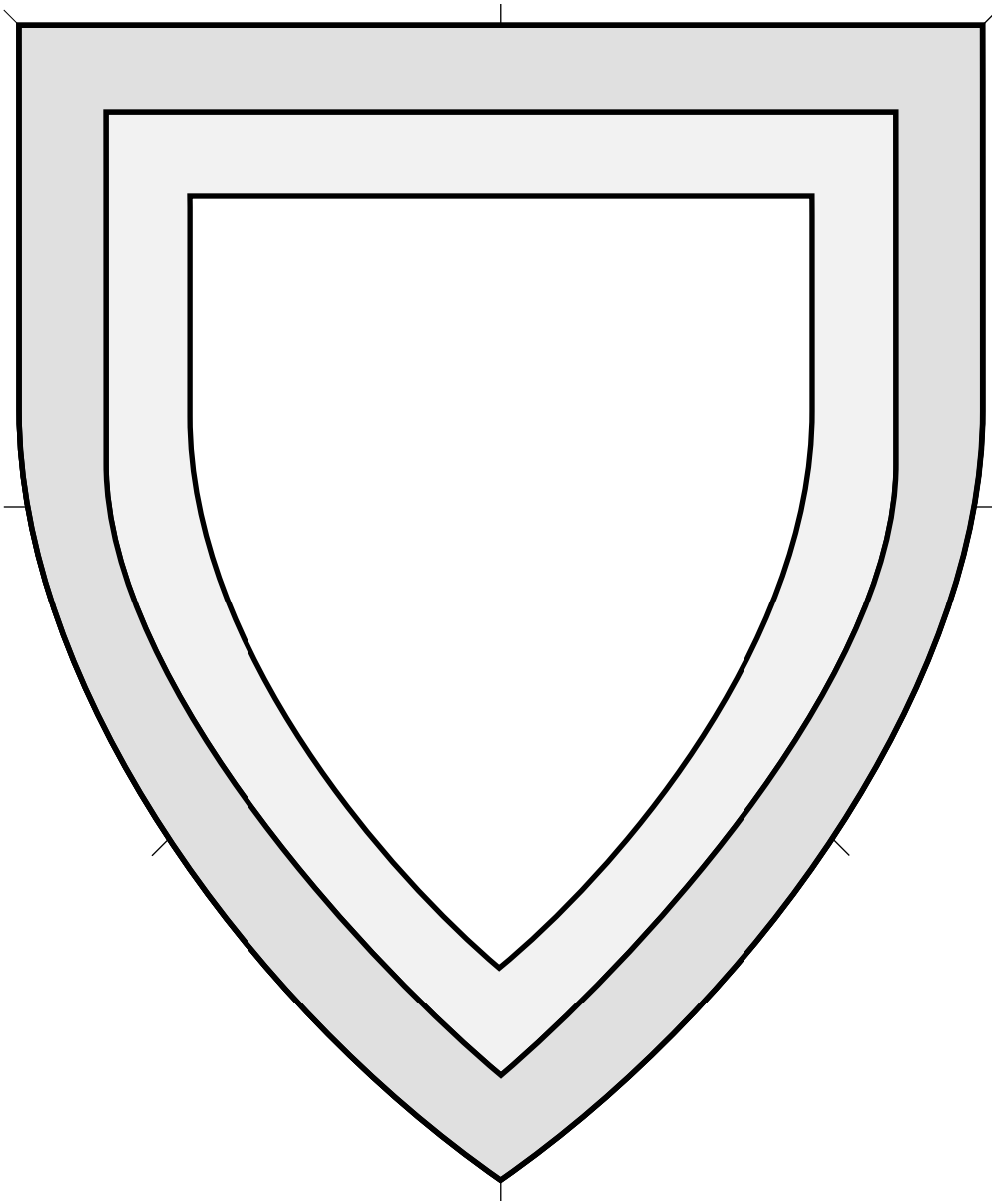

Peripheral ordinary. This bordure is separated into two equally-sized bands of contrasting tinctures.

The inner tincture is blazoned first, "a bordure parted bordurewise, *tincture* and *tincure*."

Bordure Parted Bordurewise 4.180

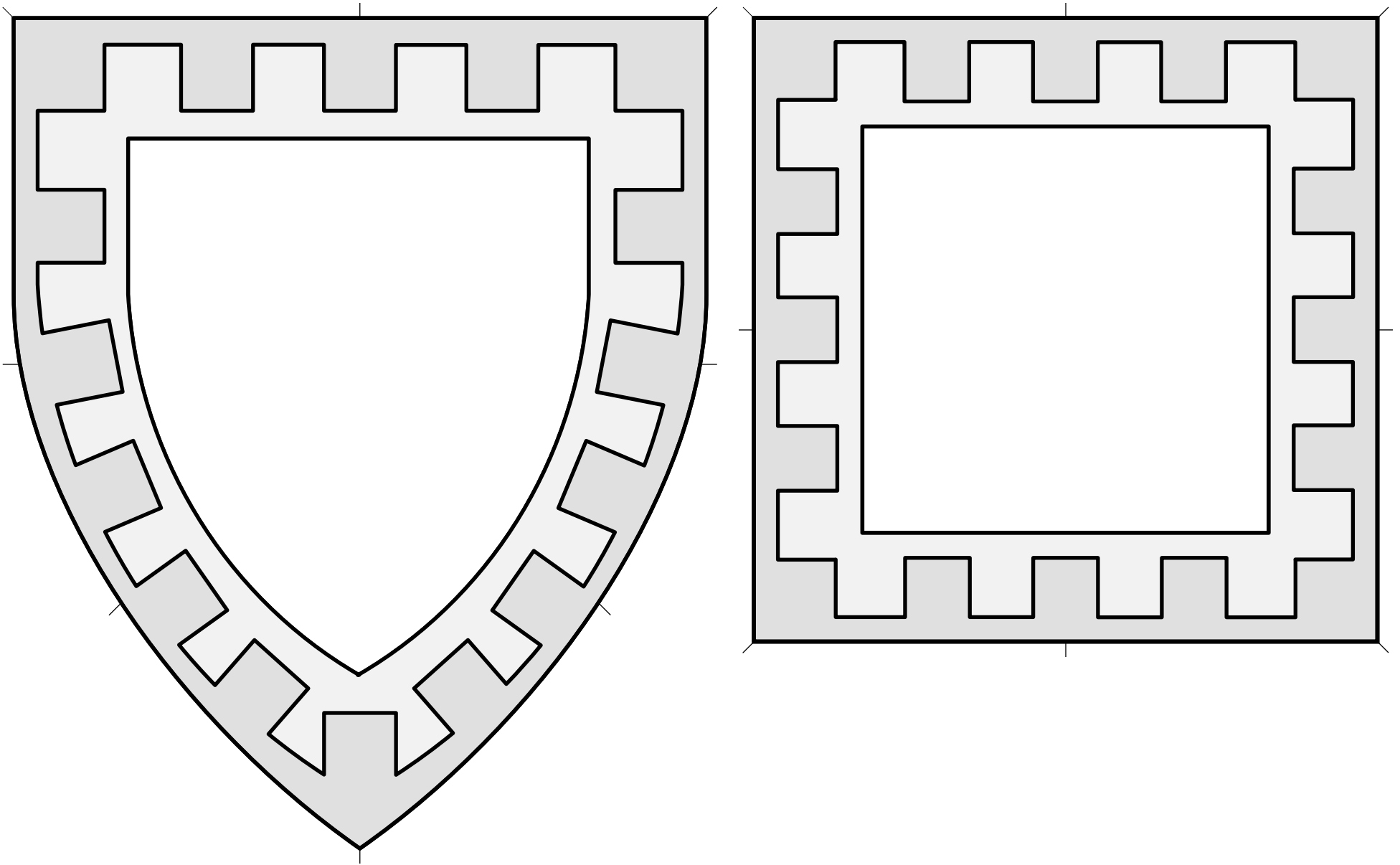

Peripheral ordinary. This bordure is separated into two equally-sized bands of contrasting tinctures, divided by a complex line.

Source: Viking Answer Lady SVG Images For Heraldry. Artist: Gunnvôr silfrhárr. Adapted by Mathghamhain Ua Ruadháin.

Bordure Parted Bordurewise Embattled 4.181

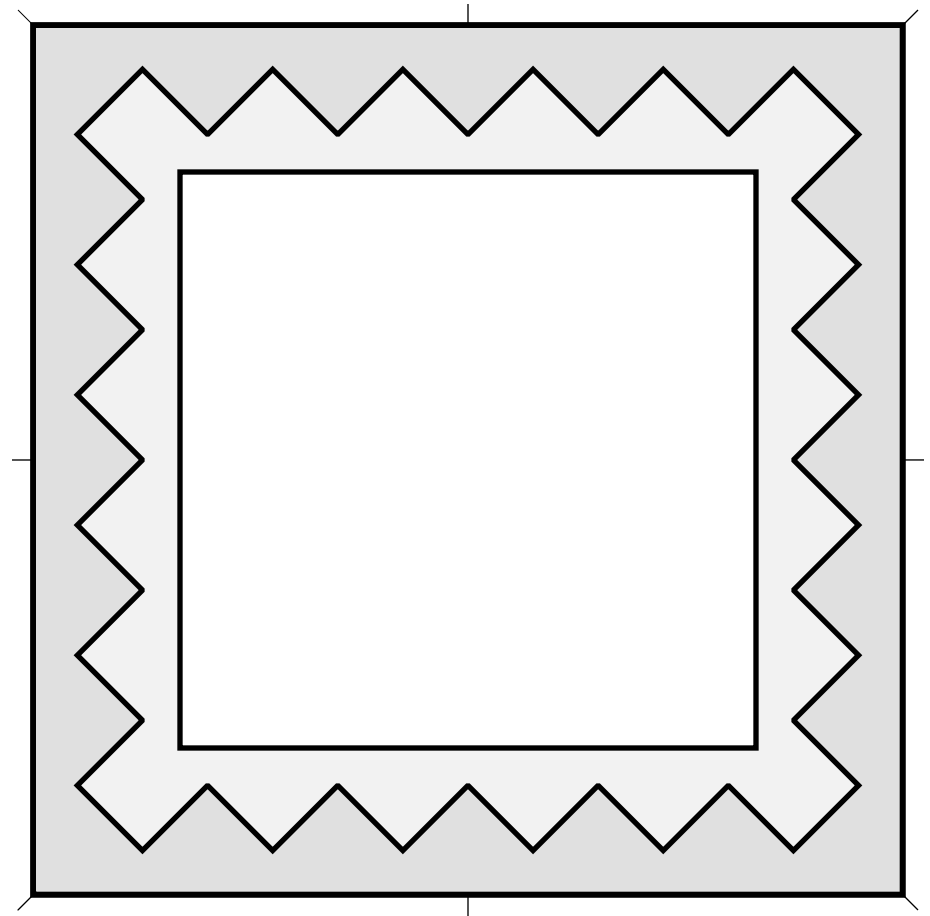
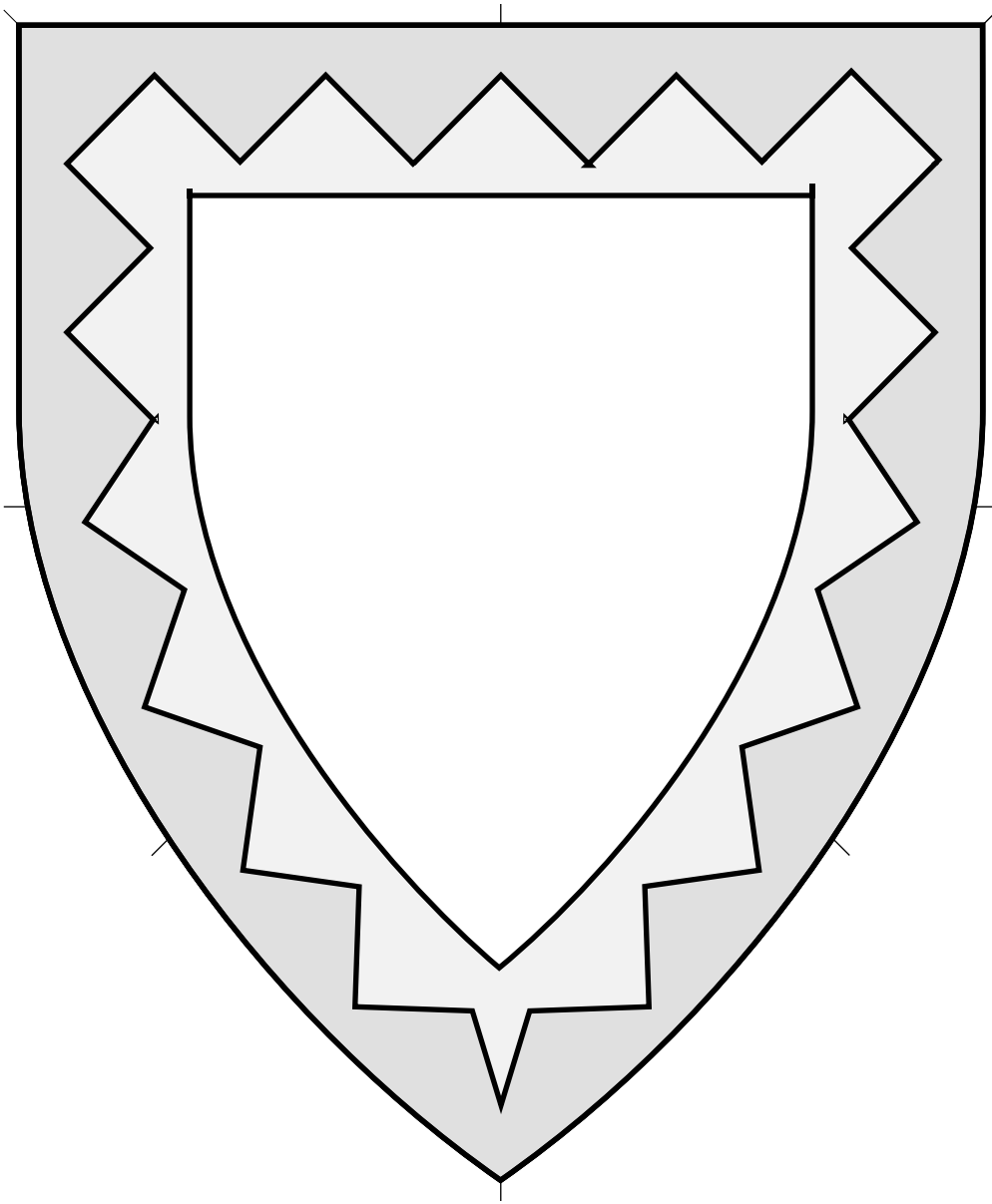

Peripheral ordinary. This bordure is separated into two equally-sized bands of contrasting tinctures, divided by a complex line.

The inner tincture is blazoned first, “a bordure parted bordurewise indented, *tincture* and *tincure*.”

Bordure Parted Bordurewise Indented (1) 4.182

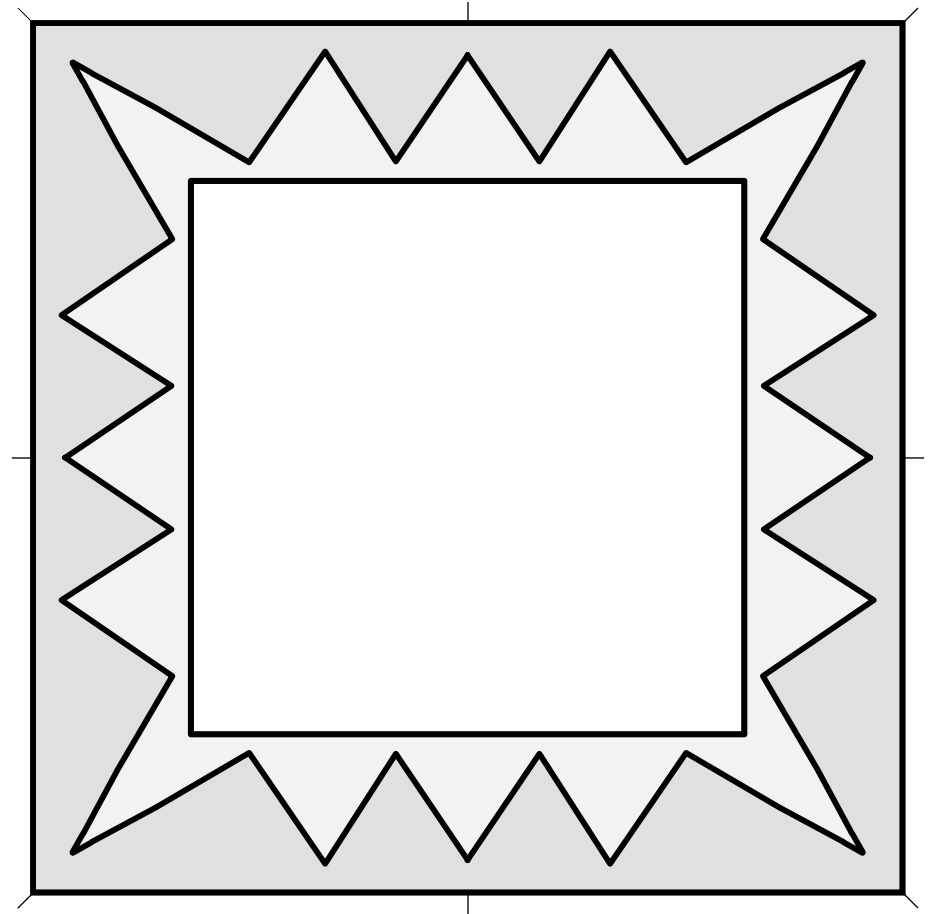
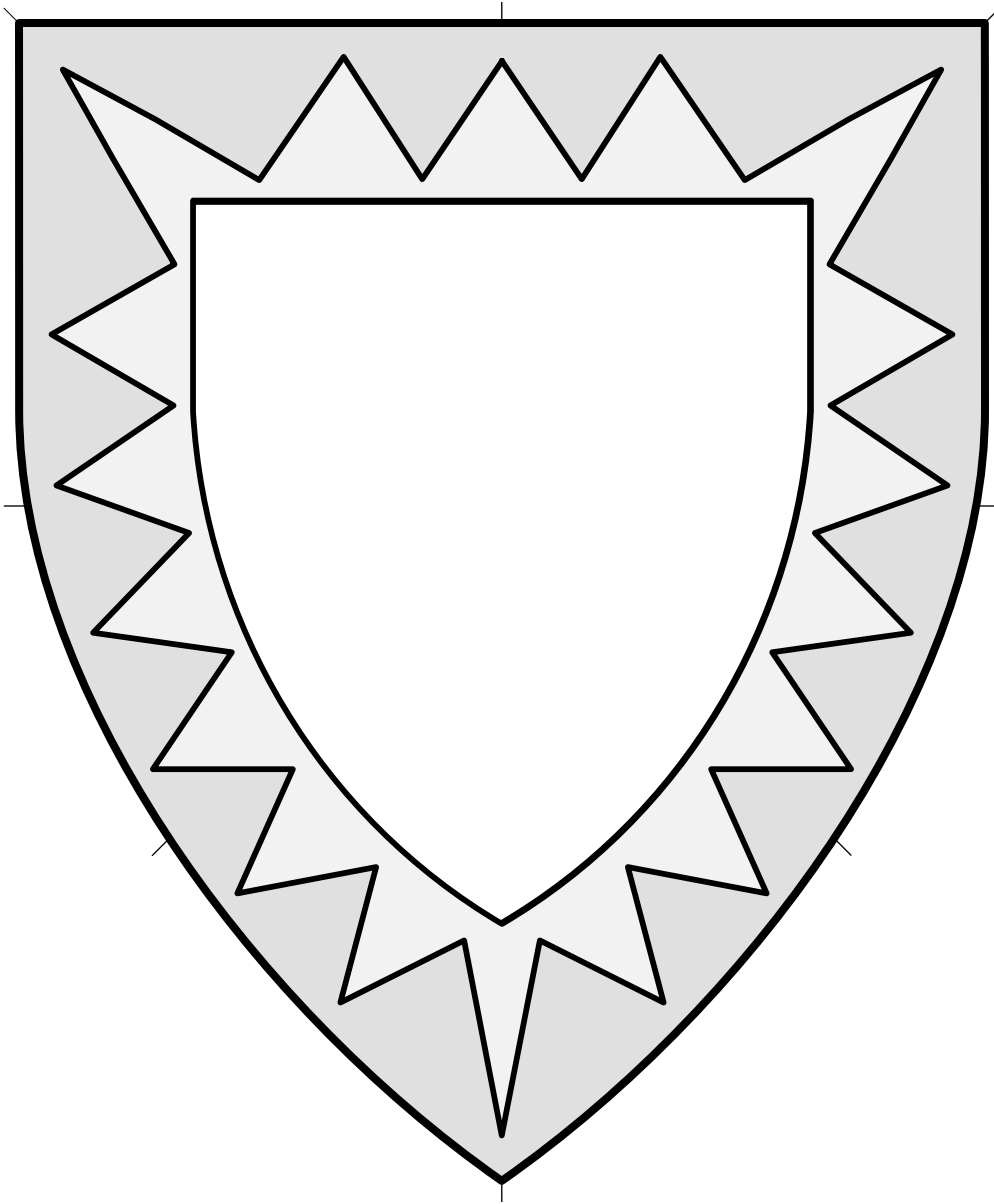

Peripheral ordinary. This bordure is separated into two equally-sized bands of contrasting tinctures, divided by a complex line.

Source: Viking Answer Lady SVG Images For Heraldry. Artist: Gunnvôr silfrhárr. Adapted by Mathghamhain Ua Ruadháin.

Bordure Parted Bordurewise Indented (2) 4.183

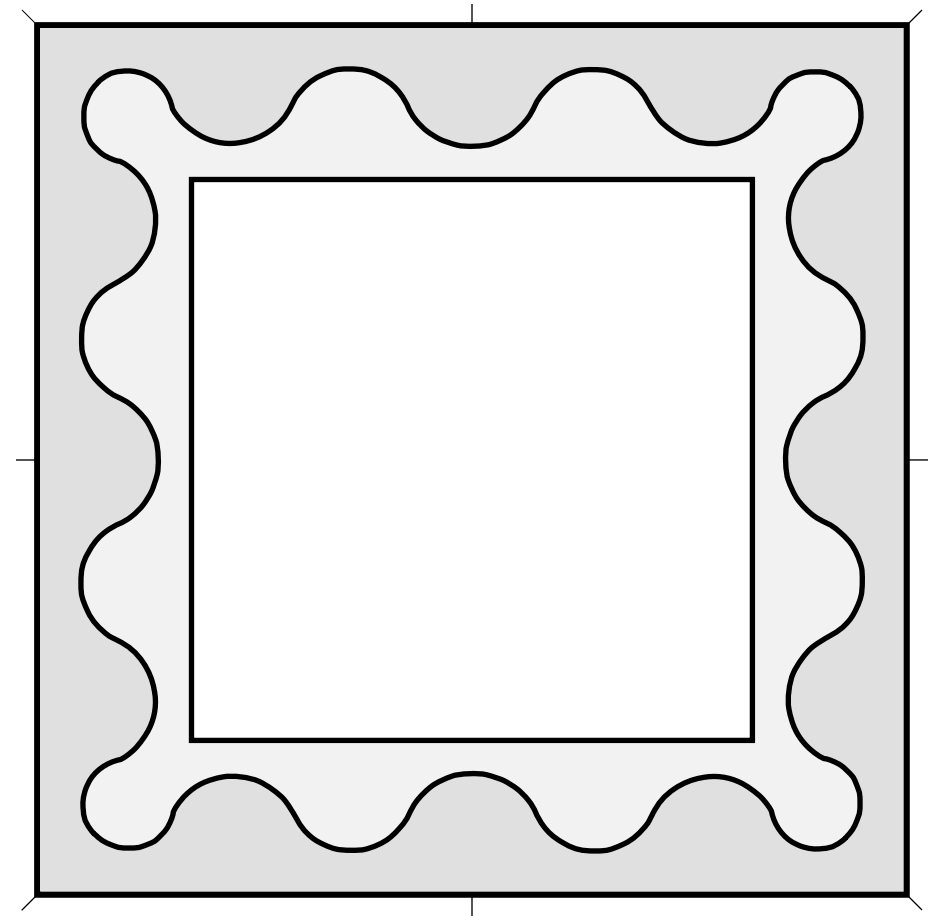
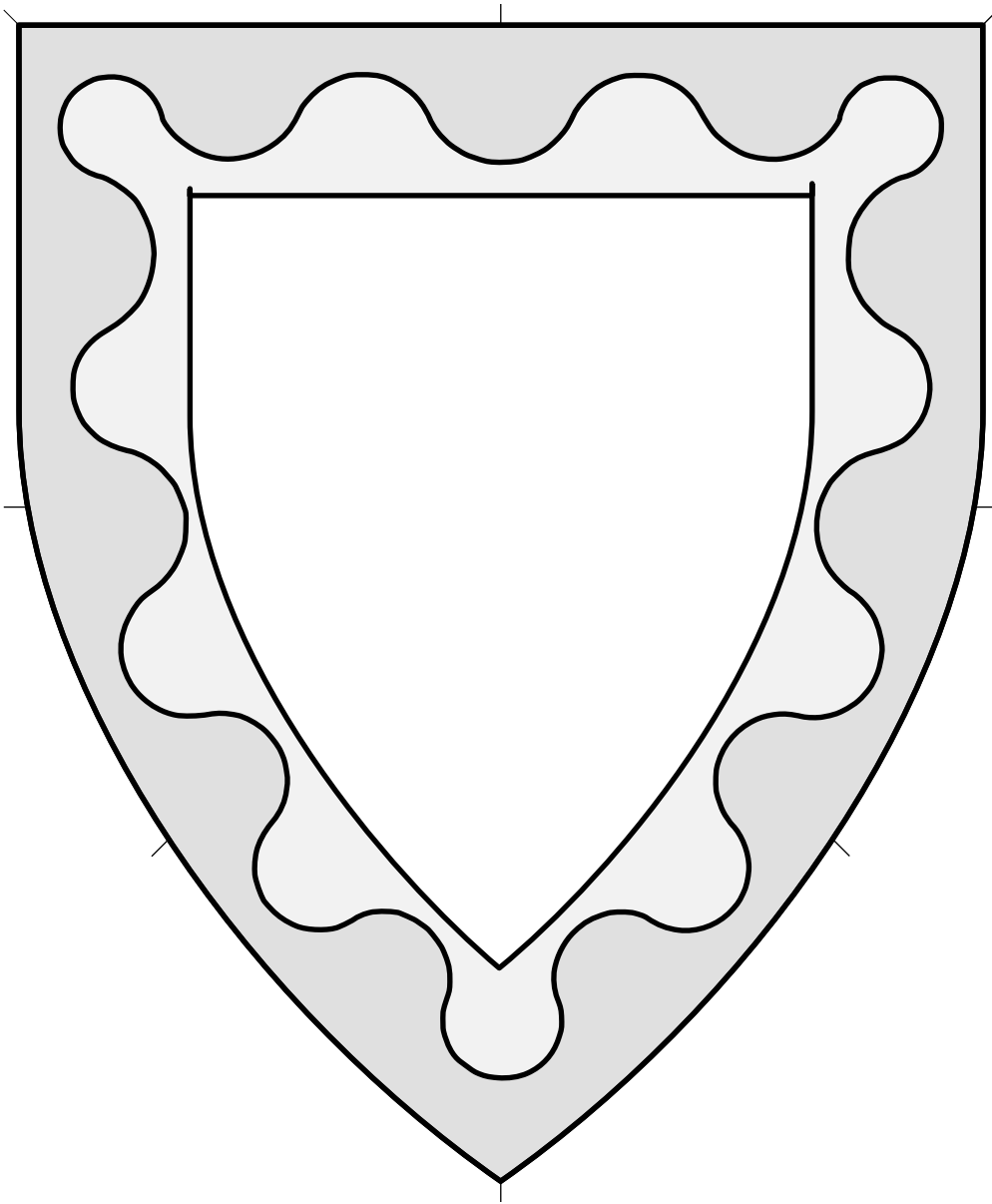

Peripheral ordinary. This bordure is separated into two equally-sized bands of contrasting tinctures, divided by a complex line. The inner tincture is blazoned first, “a bordure parted bordurewise wavy, *tincture* and *tincture*.”

Artist: Vémundr Syvursson.

Bordure Parted Bordurewise Wavy (1) 4.184

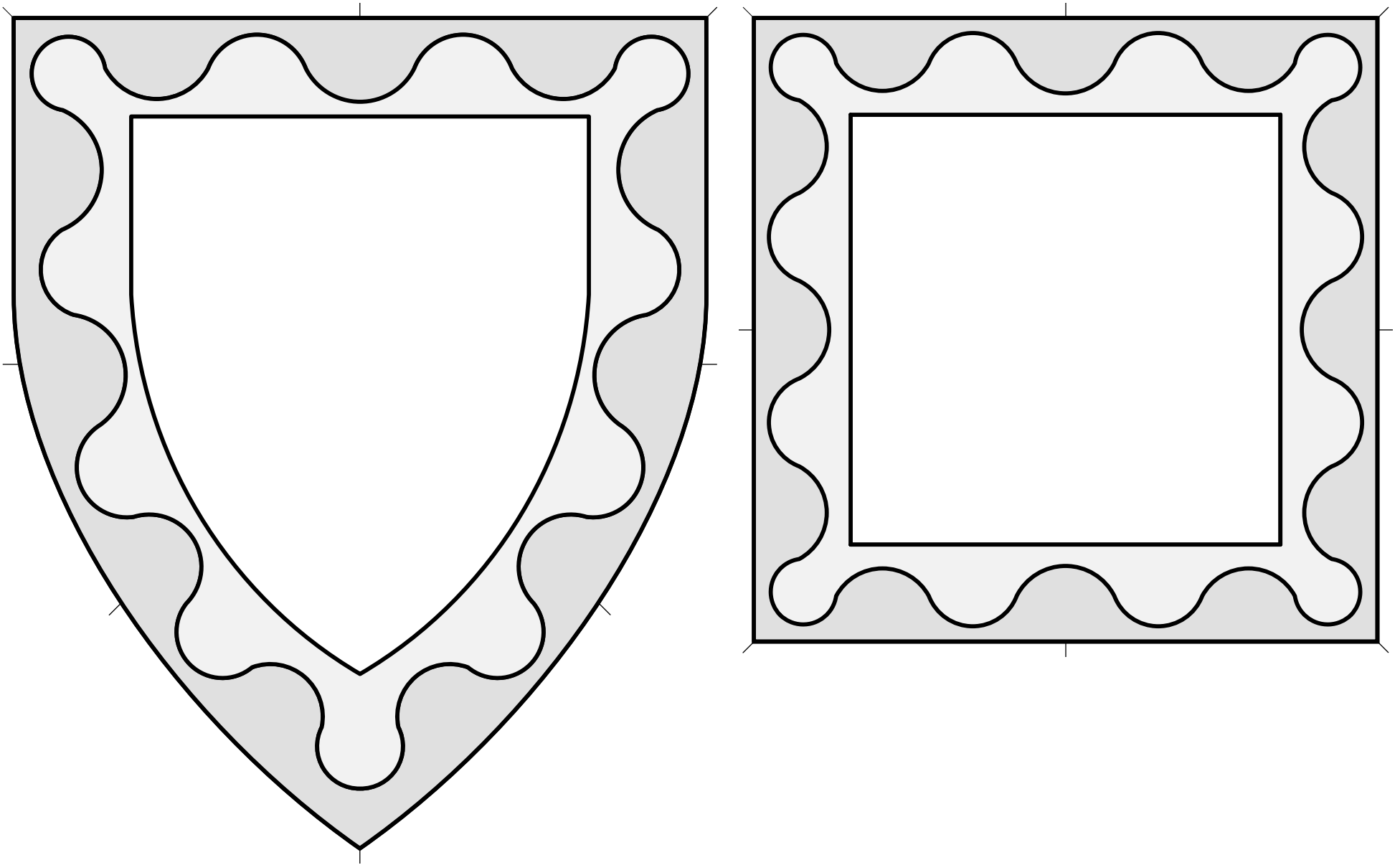

Peripheral ordinary. This bordure is separated into two equally-sized bands of contrasting tinctures, divided by a complex line.

Source: Viking Answer Lady SVG Images For Heraldry. Artist: Gunnvôr silfrhárr. Adapted by Mathghamhain Ua Ruadháin.

Bordure Parted Bordurewise Wavy (2) 4.185

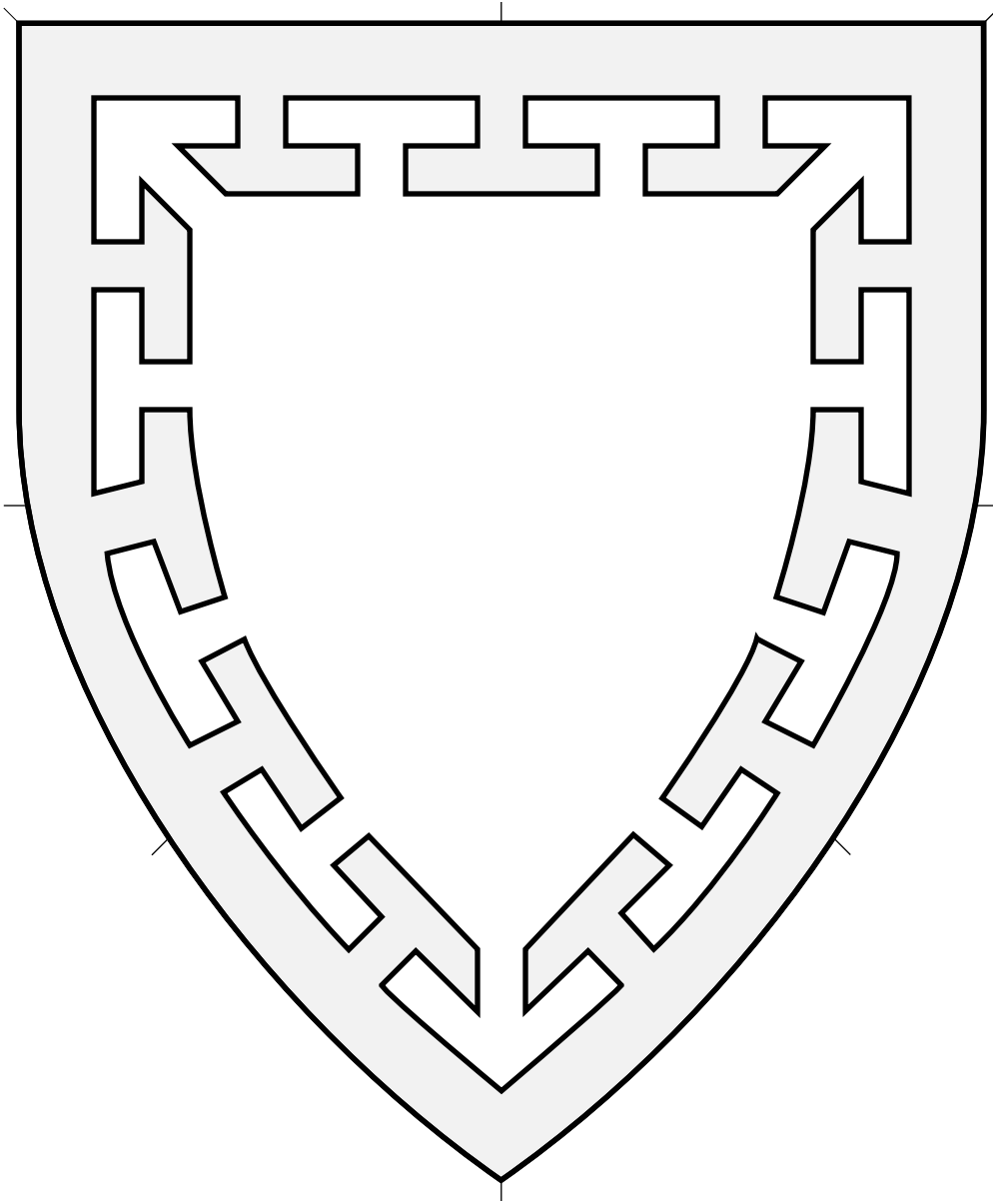

Peripheral ordinary.

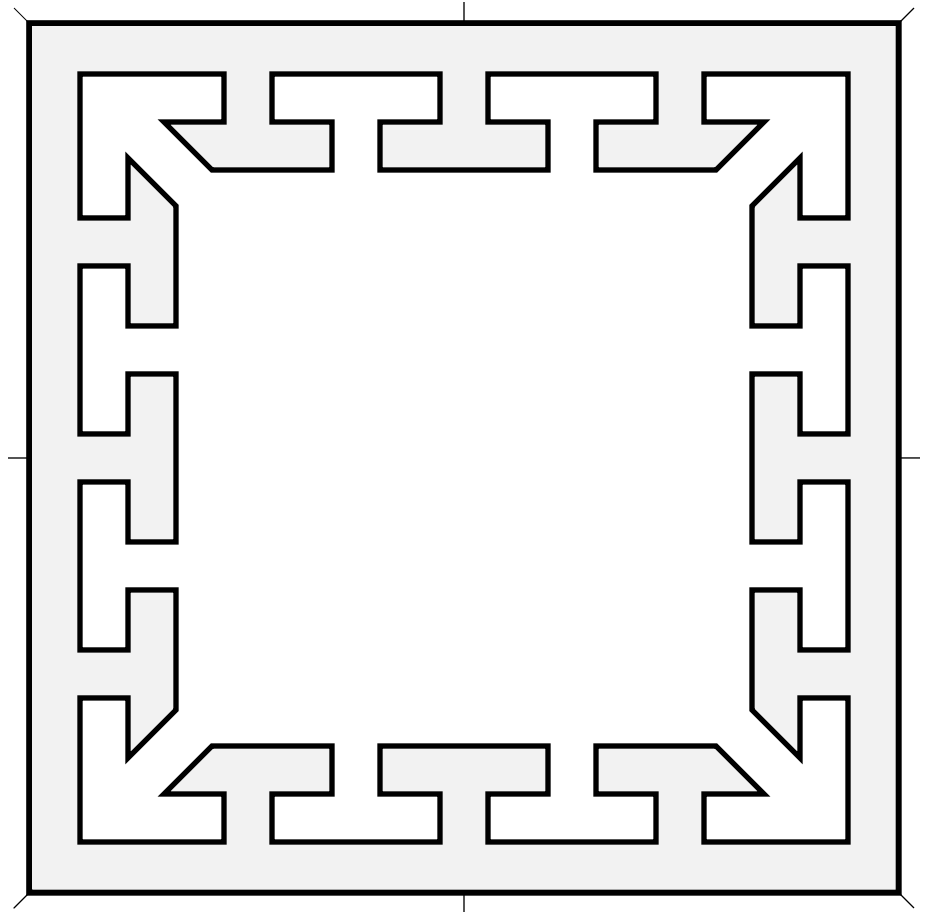

Bordure Potenty 4.186

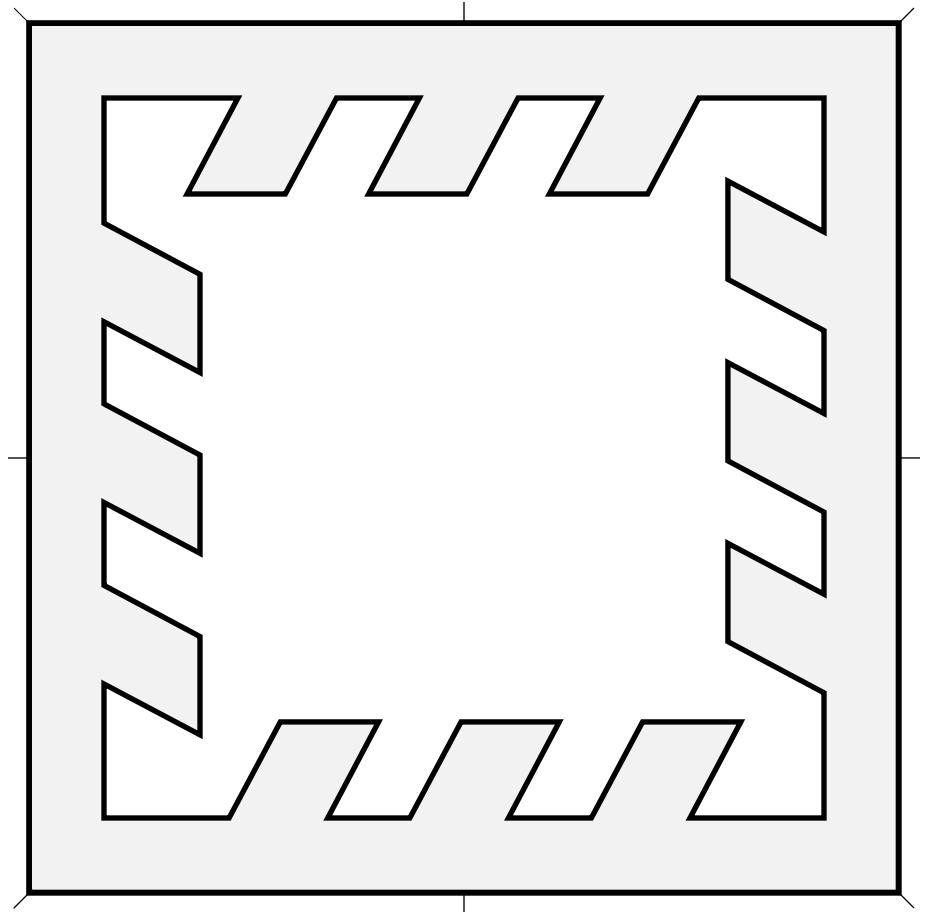
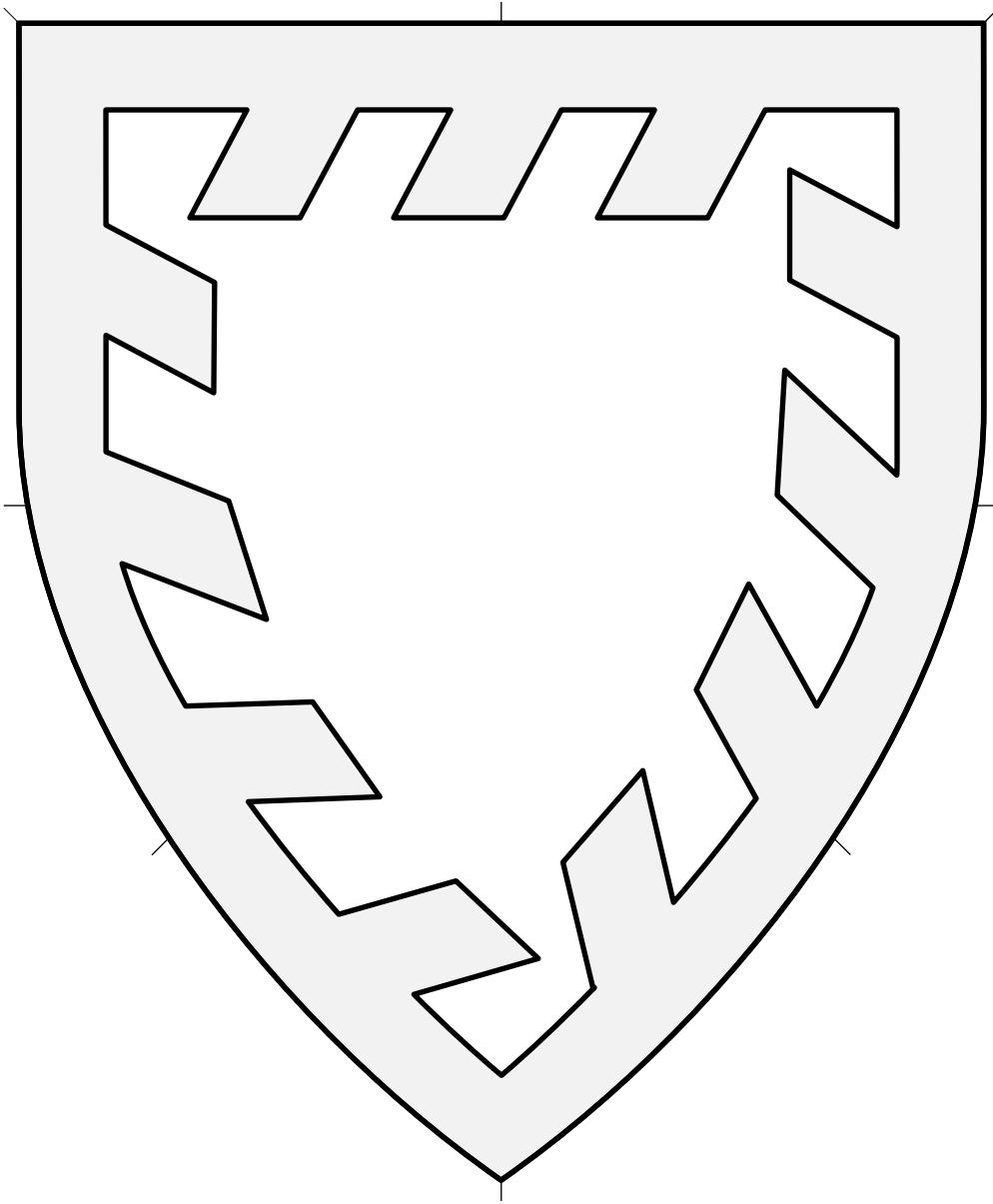

Peripheral ordinary.

Source: Heraldic Templates. Artist: Torric inn Björn.
Adapted by Mathghamhain Ua Ruadháin.

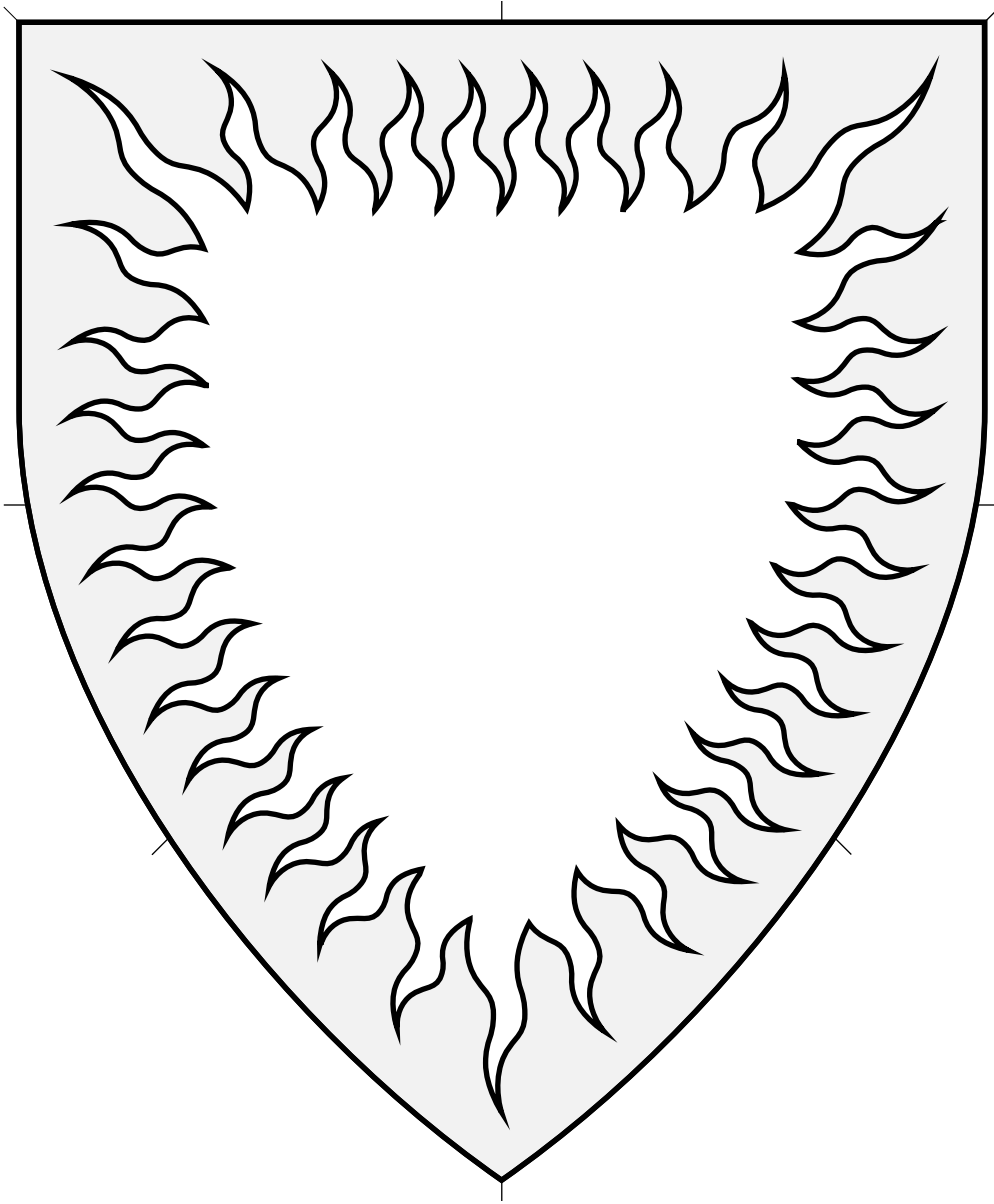

Peripheral ordinary.

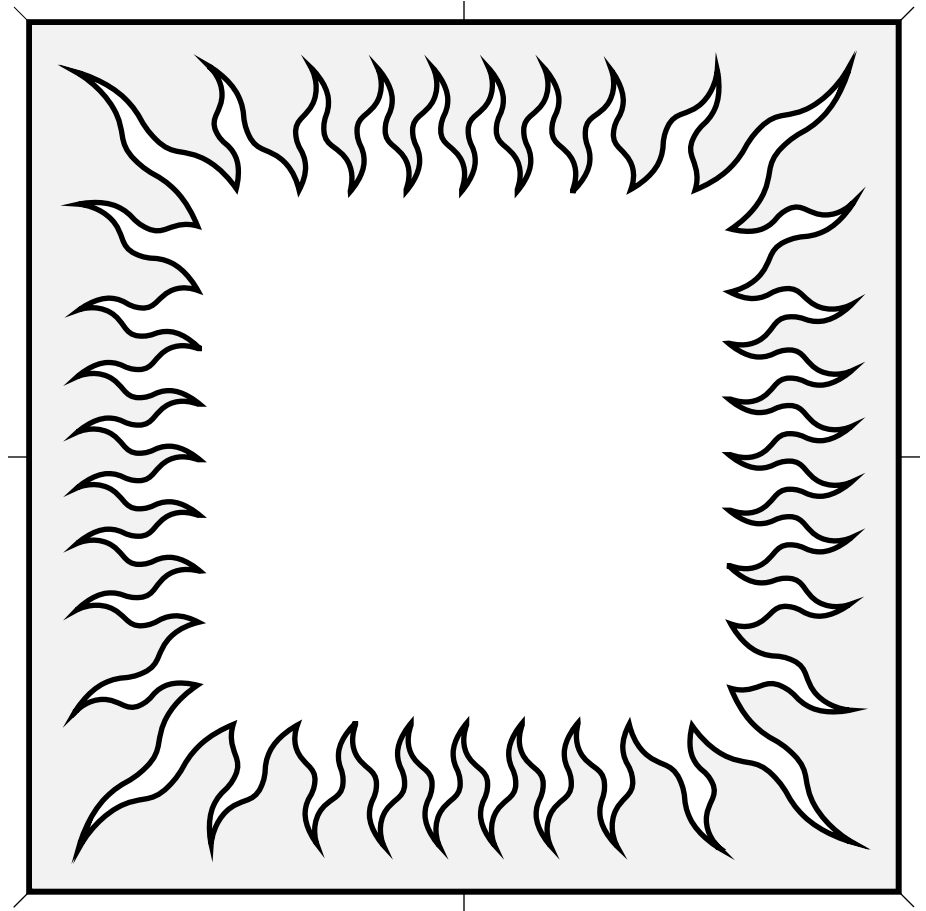

Bordure Rayonny (1) 4.188

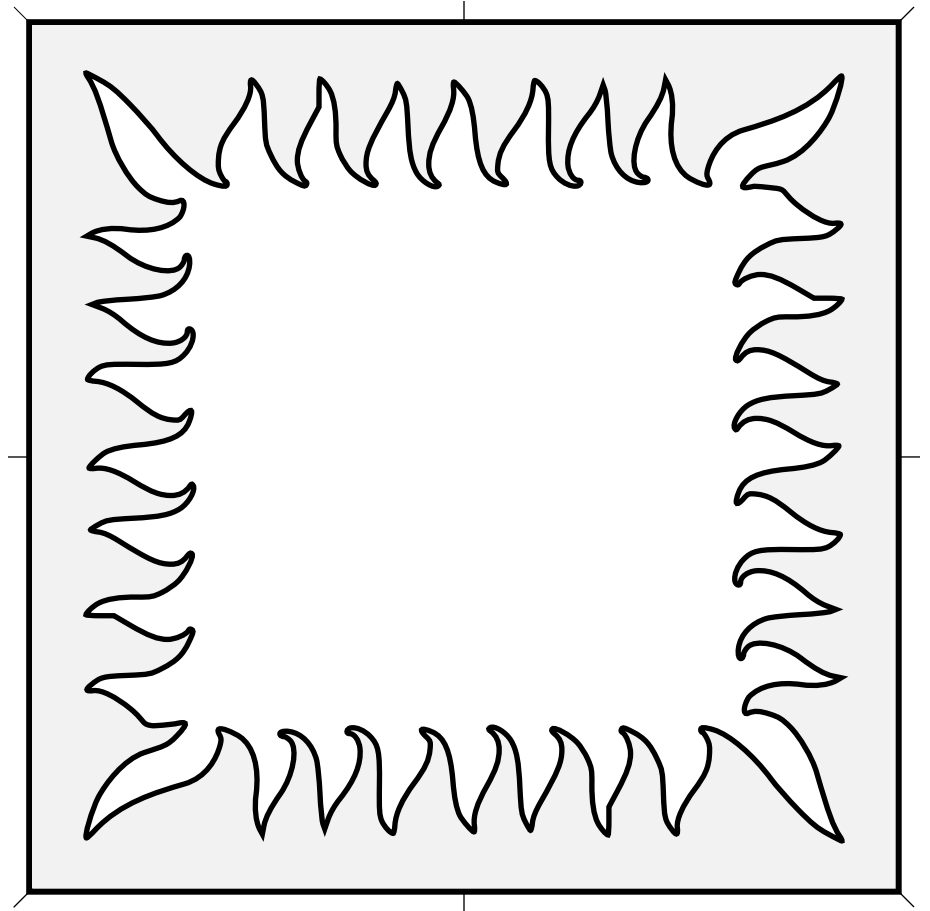
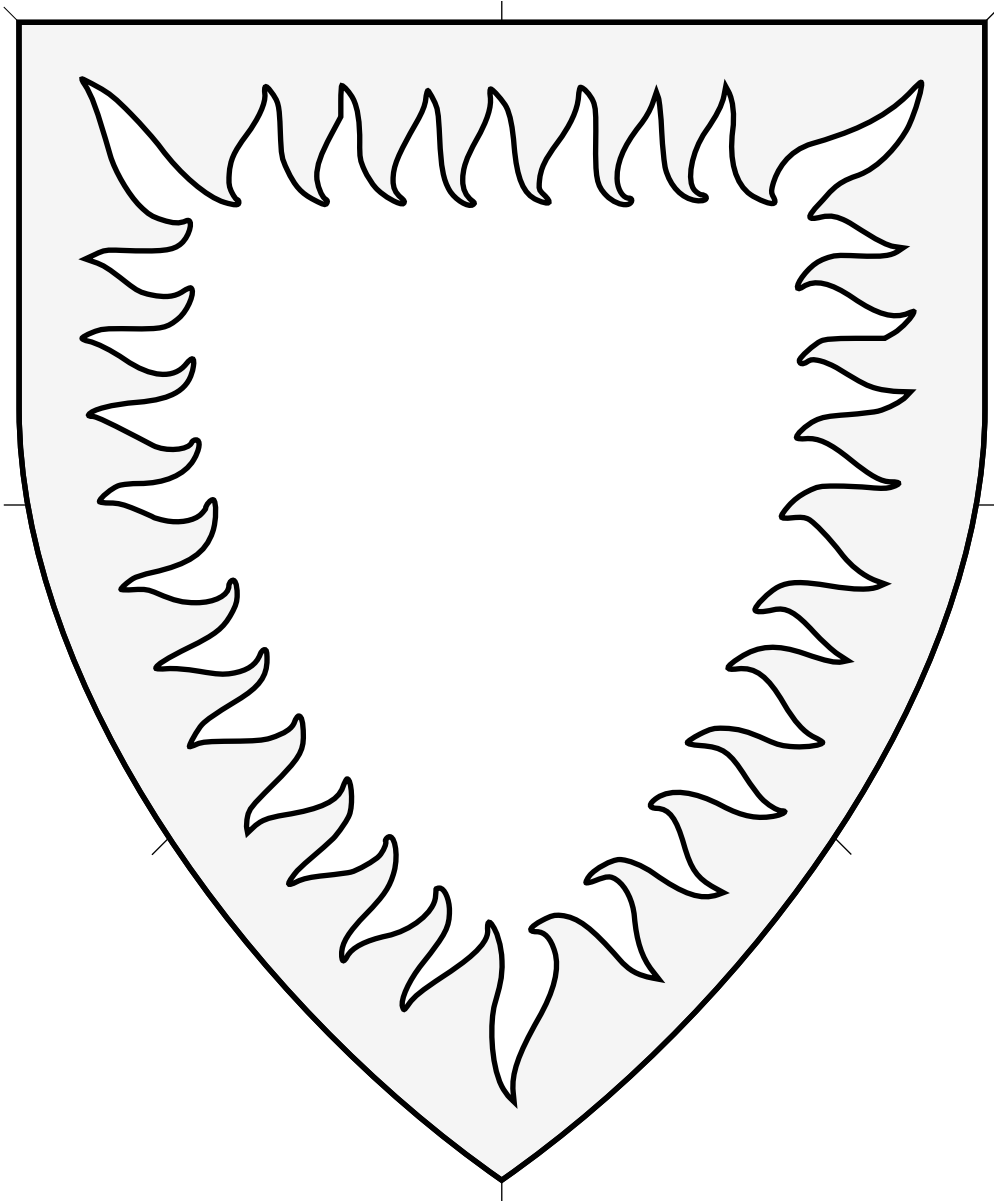

Peripheral ordinary.

Source: Heraldic Templates. Artist: Torric inn Björn.
Adapted by Mathghamhain Ua Ruadháin.

Bordure Rayonny (2) 4.189

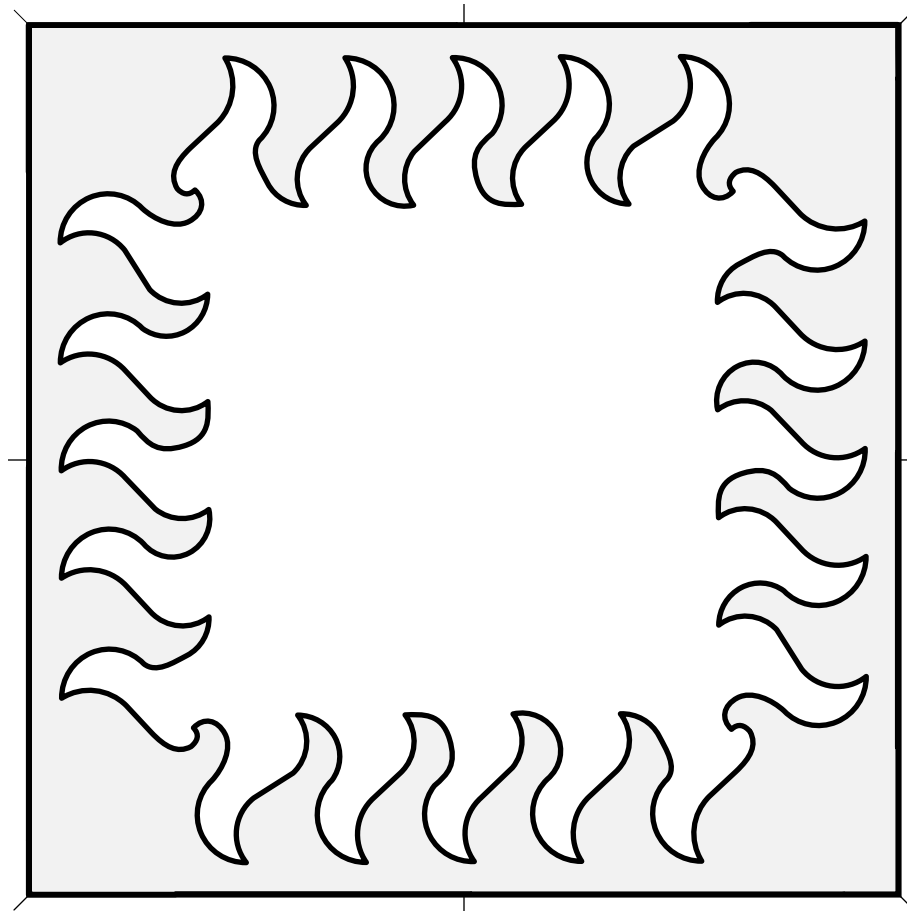
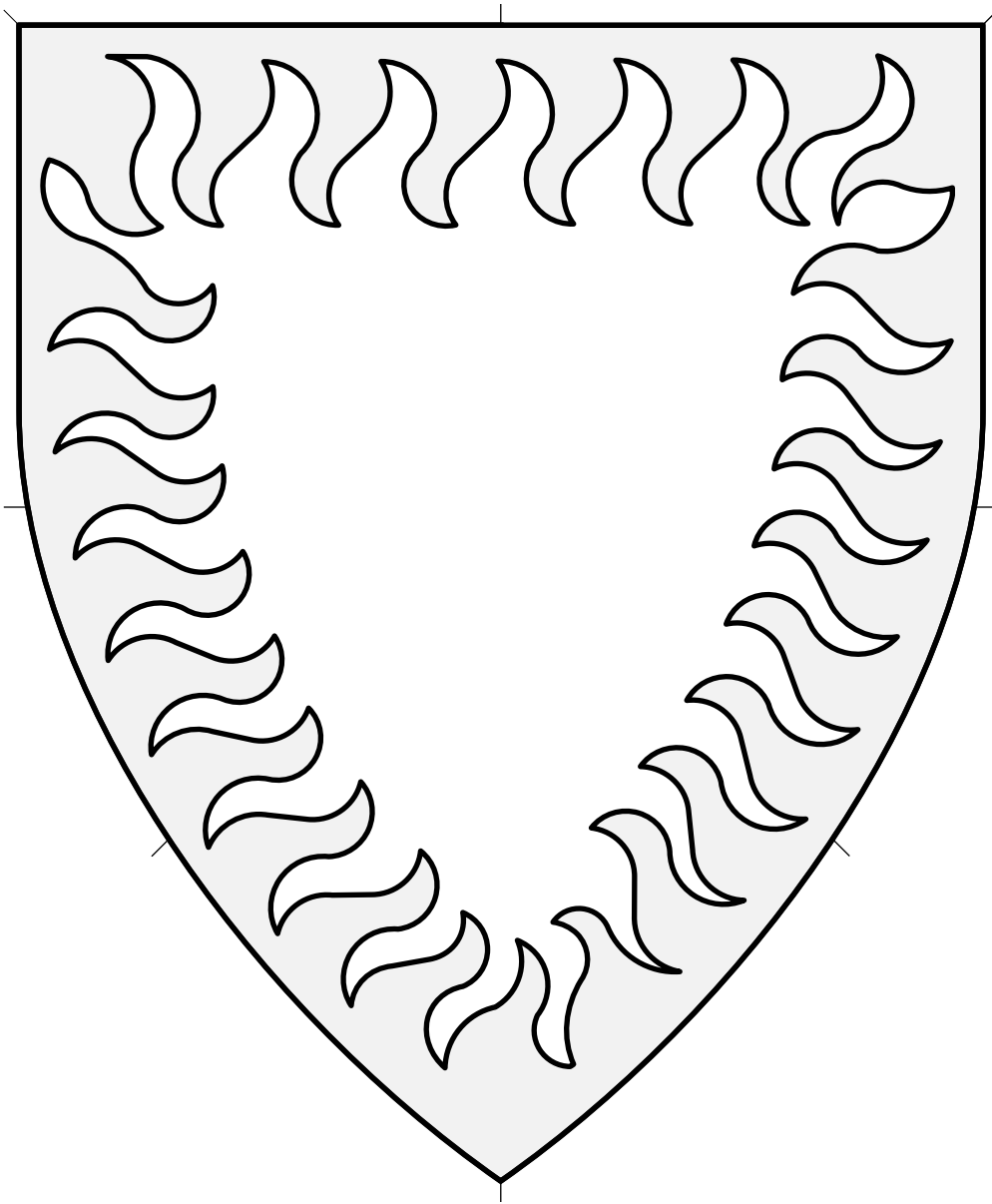

Peripheral ordinary.

Source: Viking Answer Lady SVG Images For Heraldry.
Artist: Gunnvôr silfrahárr. Adapted by Mathghamhain Ua Ruadháin.

Bordure Rayonny (3) 4.190

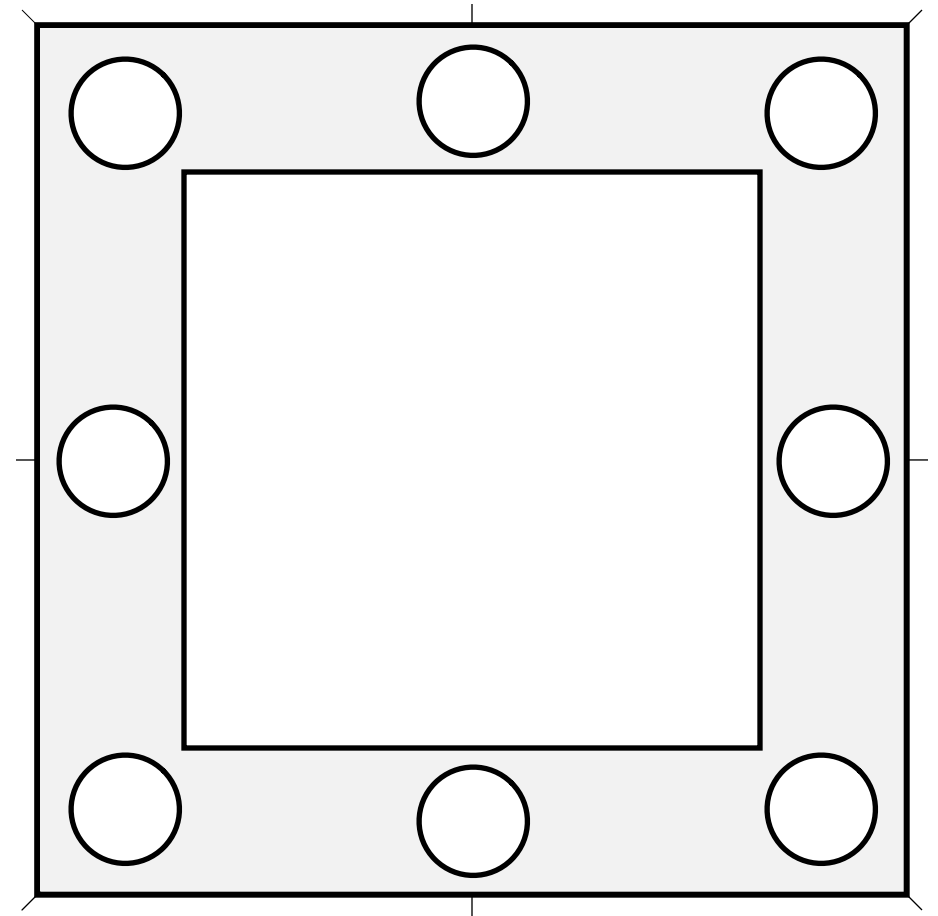
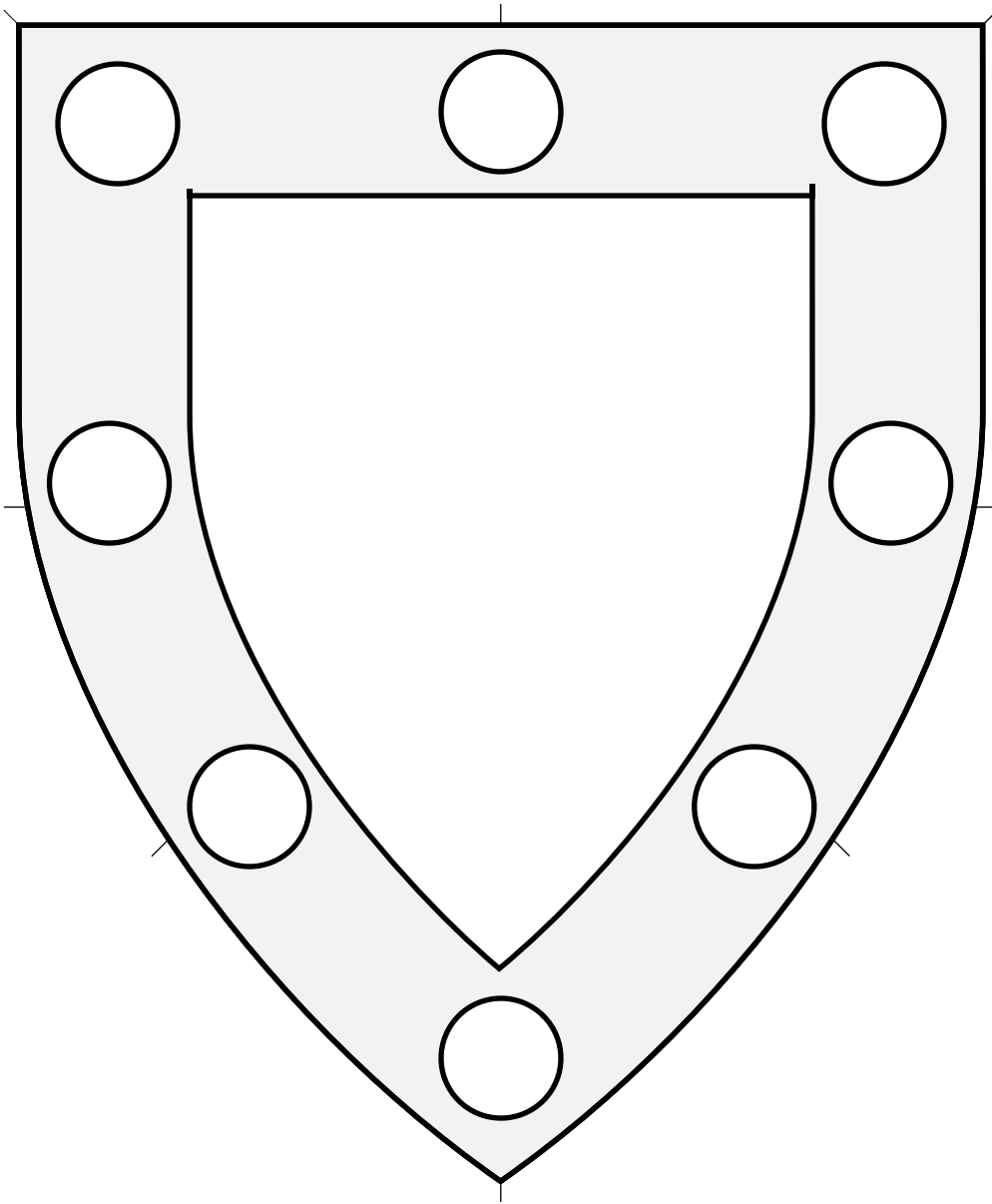

Peripheral ordinary. A bordure semy has a ring of whole charges evenly distributed around it.
This version uses roundels but you can replace them with any simple charge.

Bordure Semy (1) 4.191

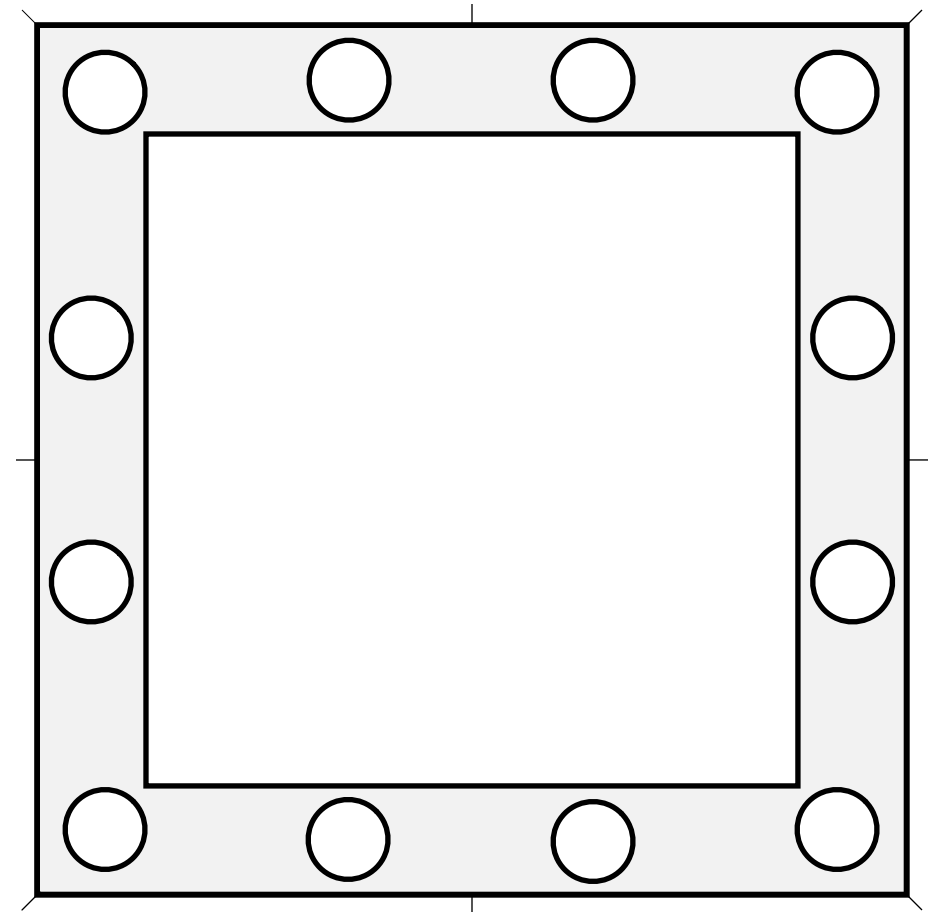
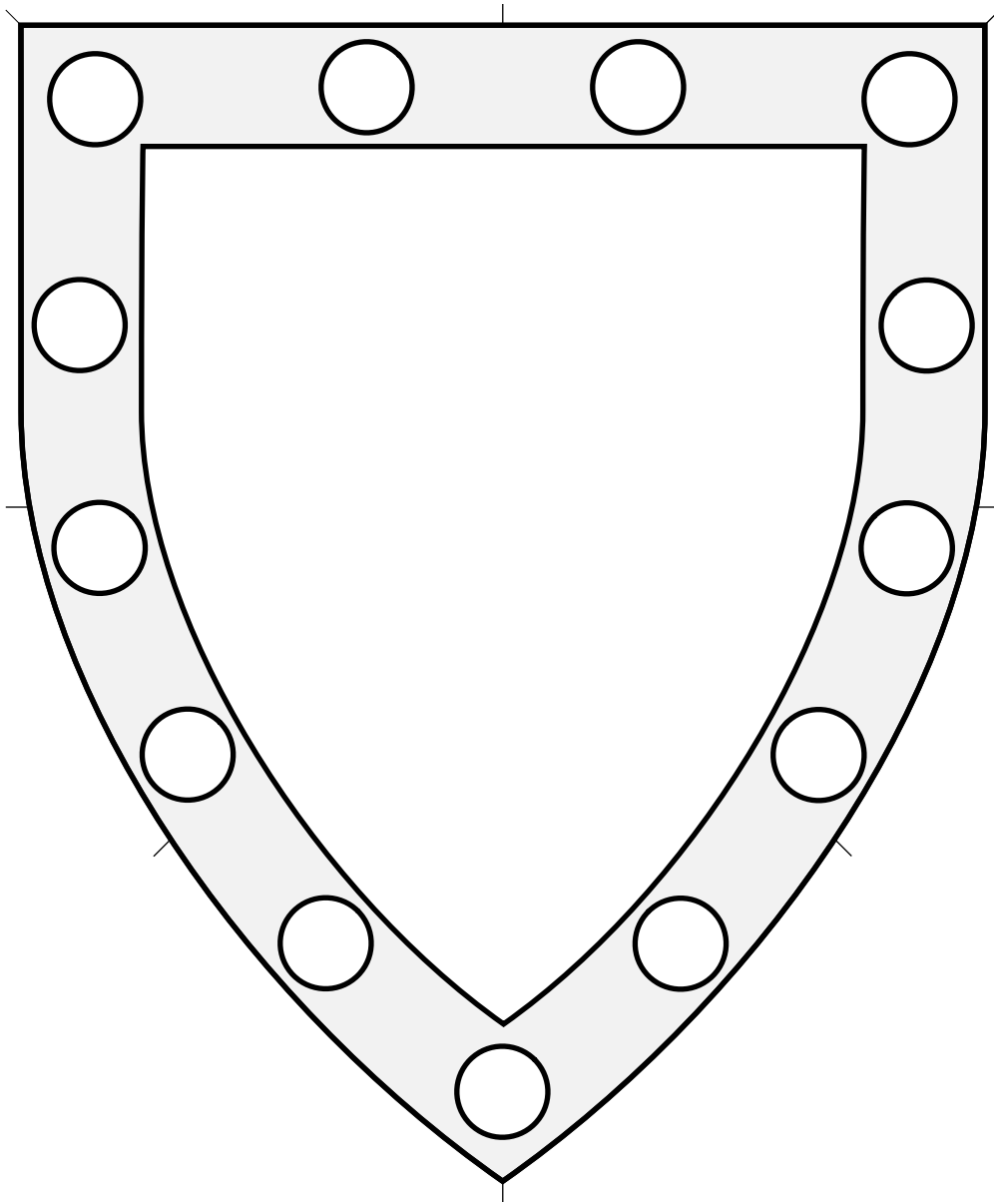

Peripheral ordinary. A bordure semy has a ring of whole charges evenly distributed around it.
This version uses roundels but you can replace them with any simple charge.

Bordure Semy (2) 4.192

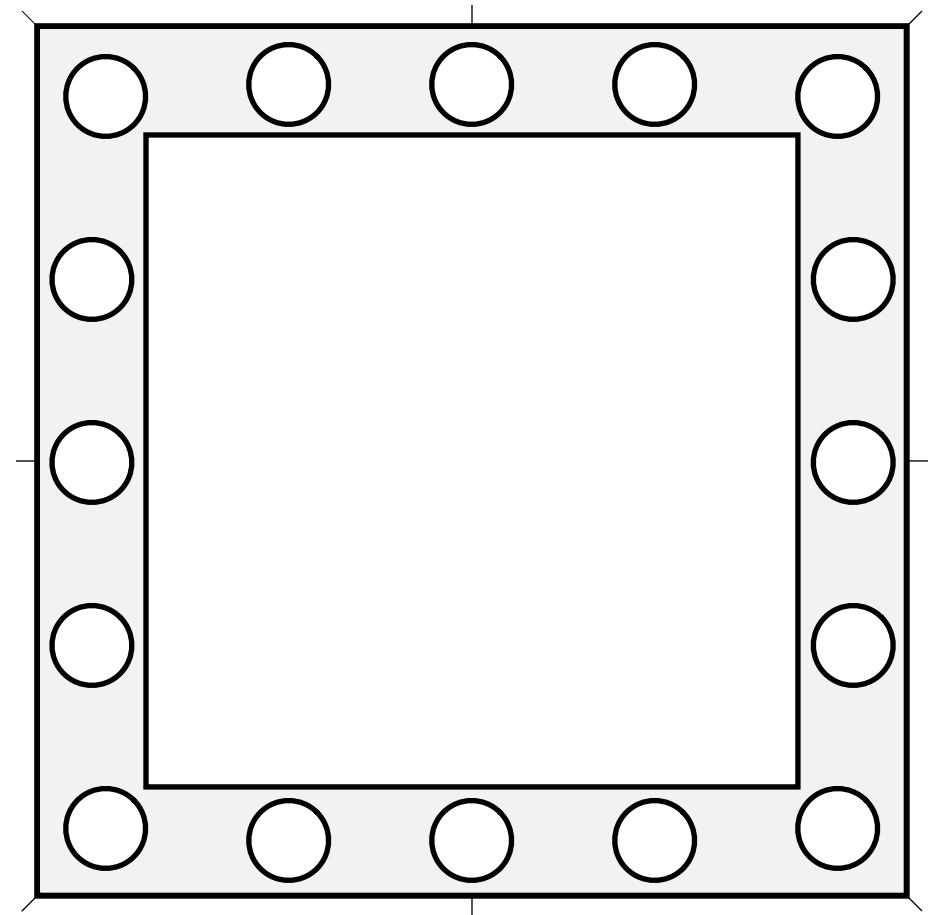
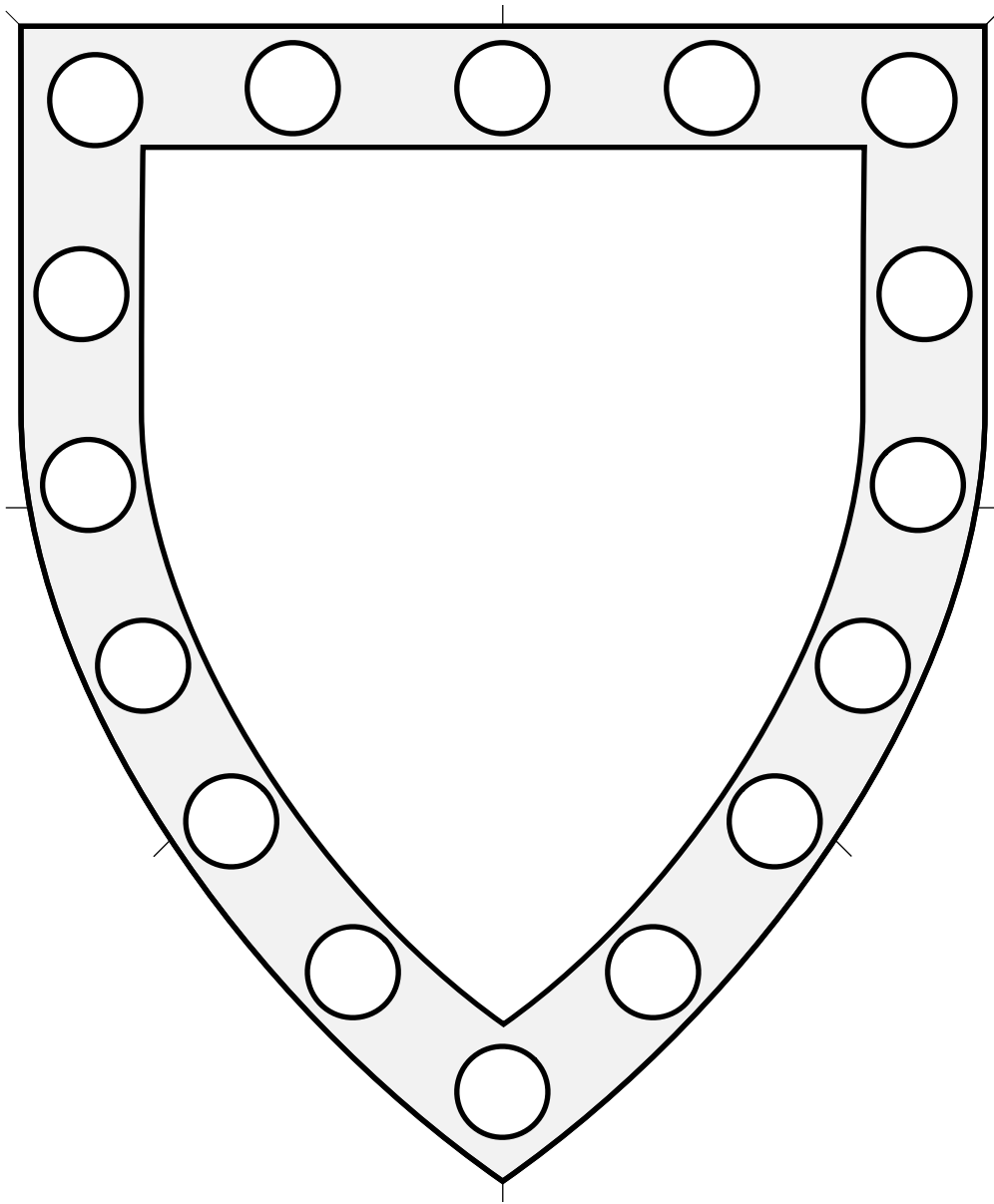

Peripheral ordinary. A bordure semy has a ring of whole charges evenly distributed around it.
This version uses roundels but you can replace them with any simple charge.

Bordure Semy (3) 4.193

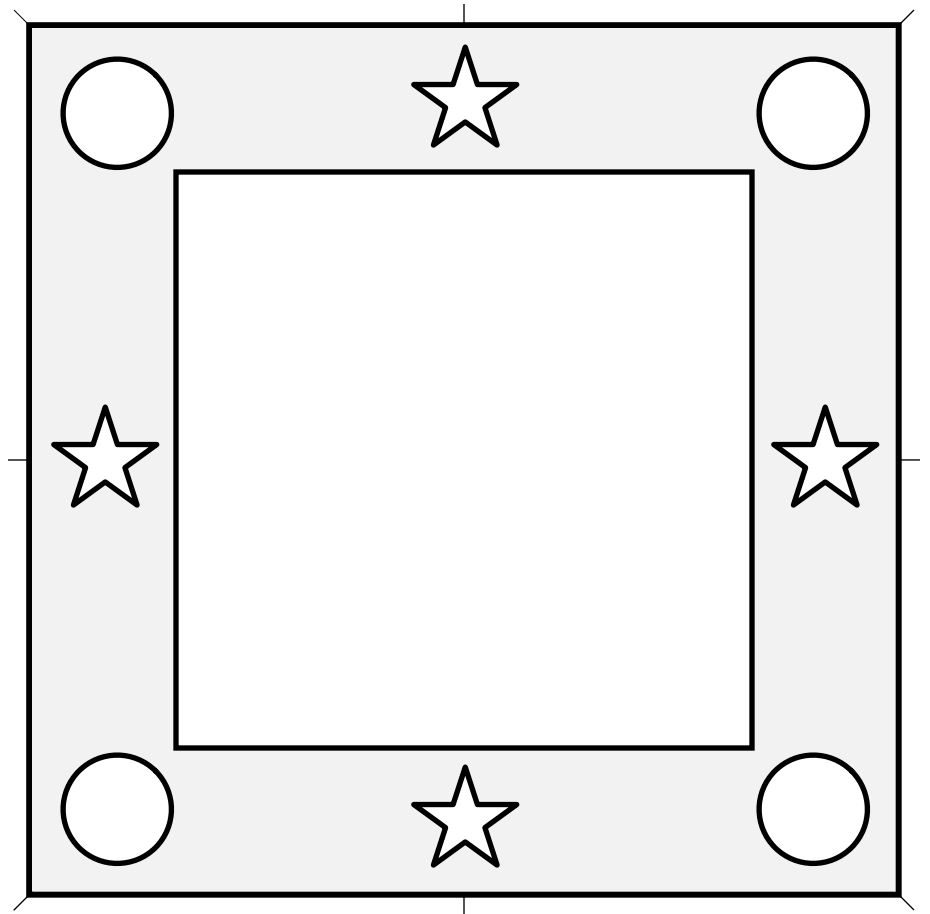
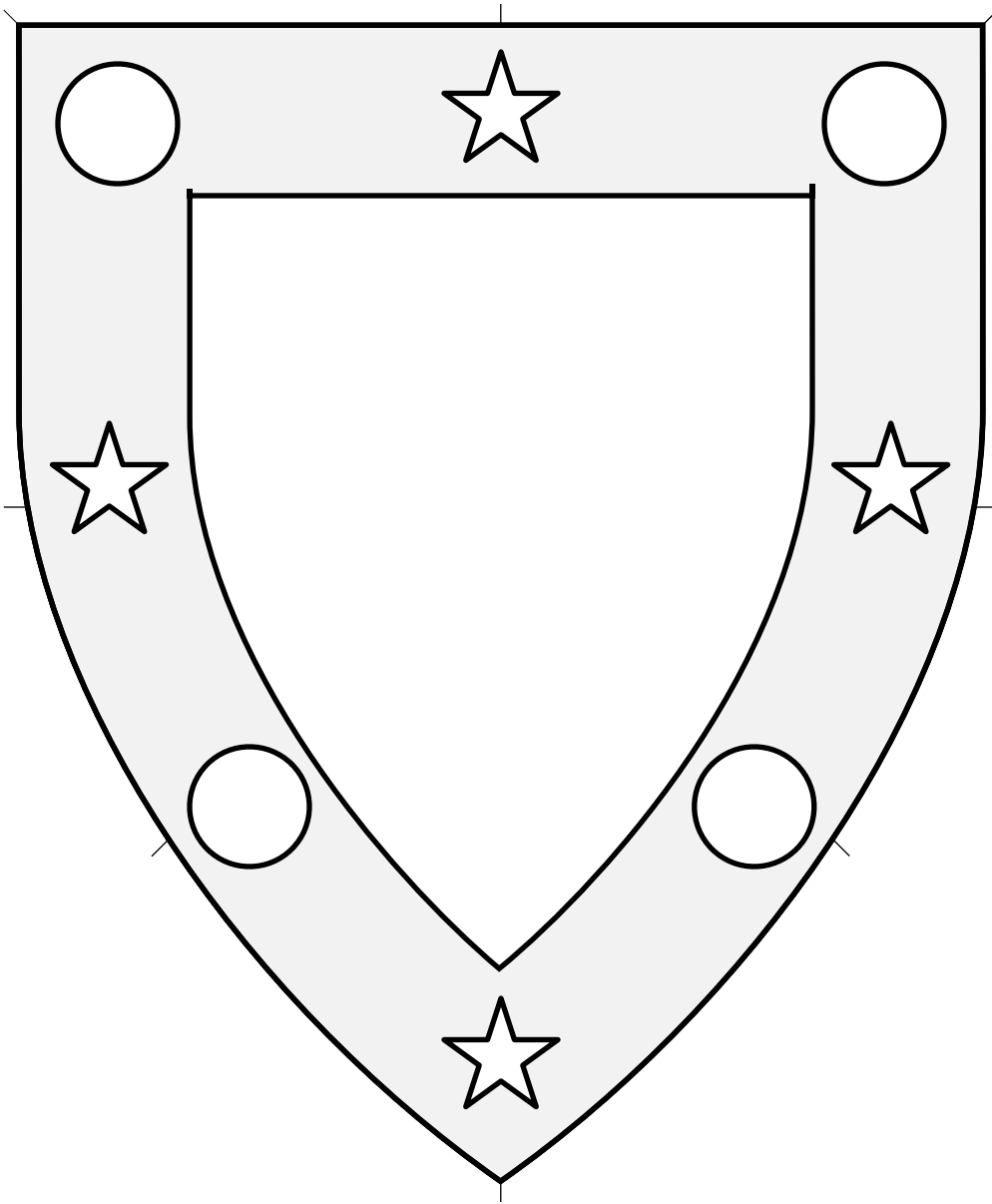

Peripheral ordinary. Bordures semy of two alternating charges are attested but extremely rare in period.

Bordure Semy Alternating 4.194

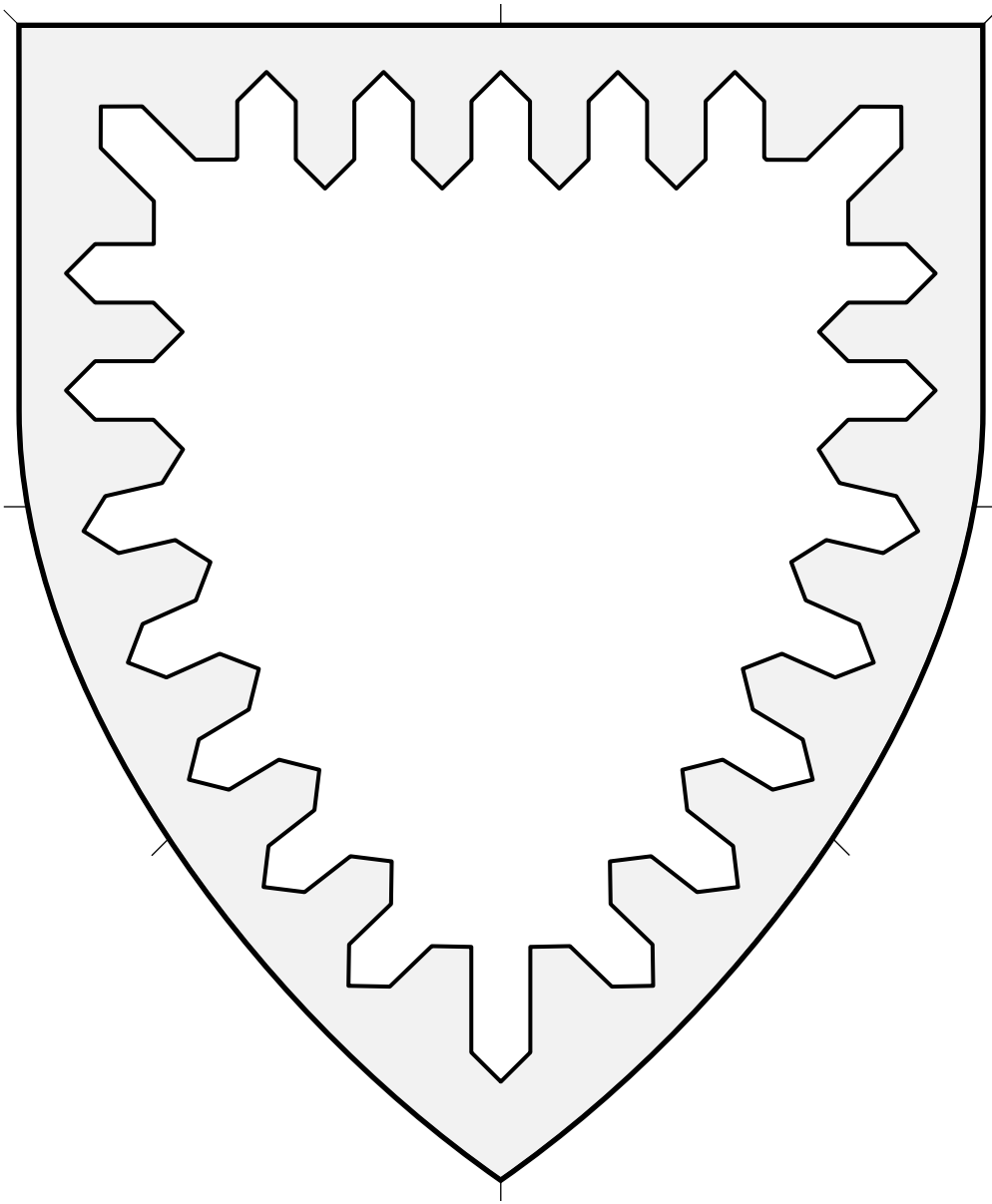

Peripheral ordinary.

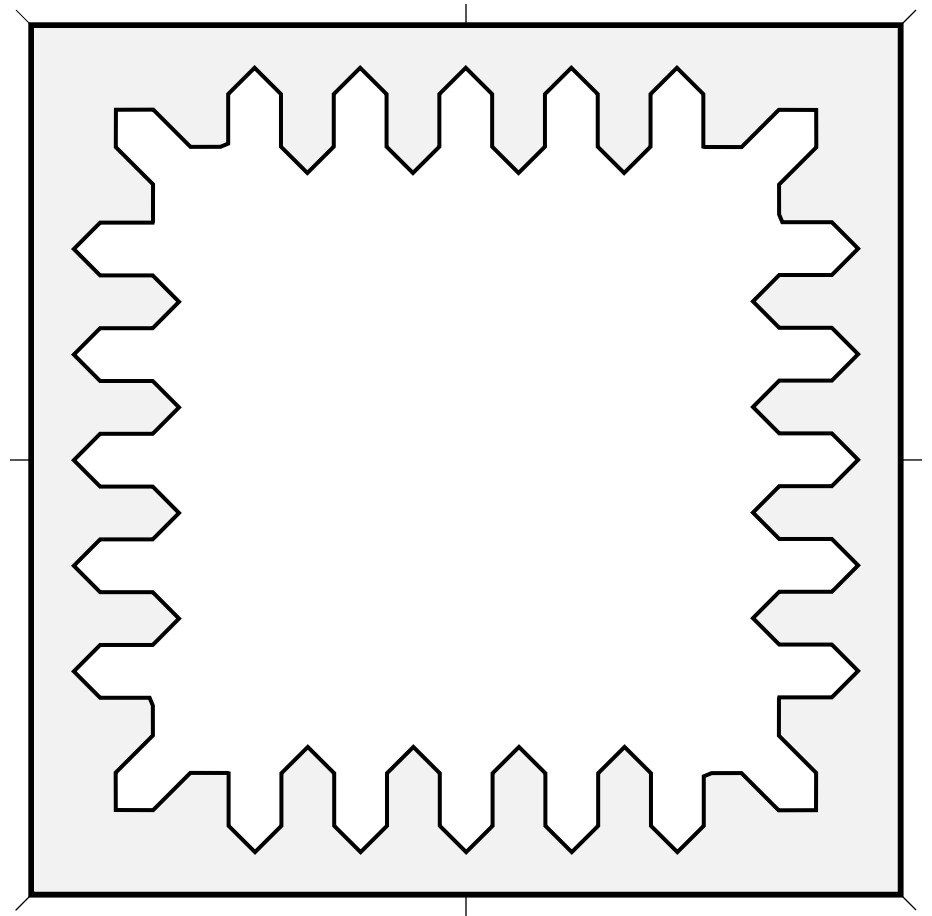

Bordure Urdy • 4.195

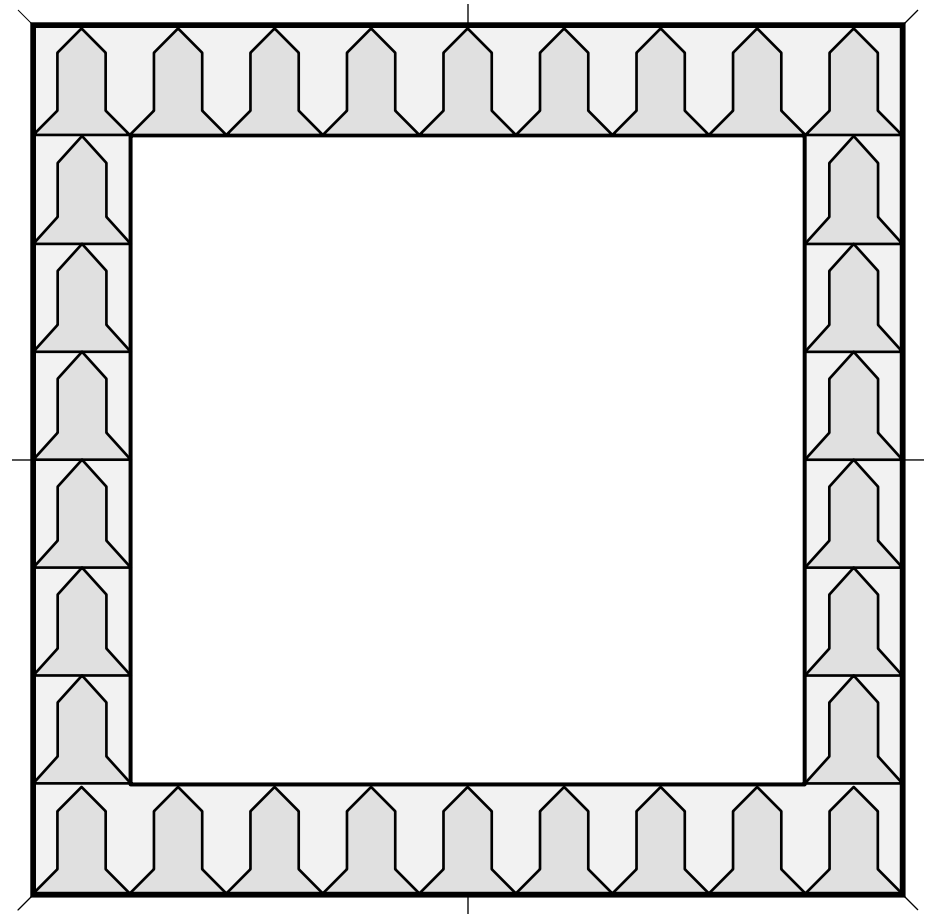
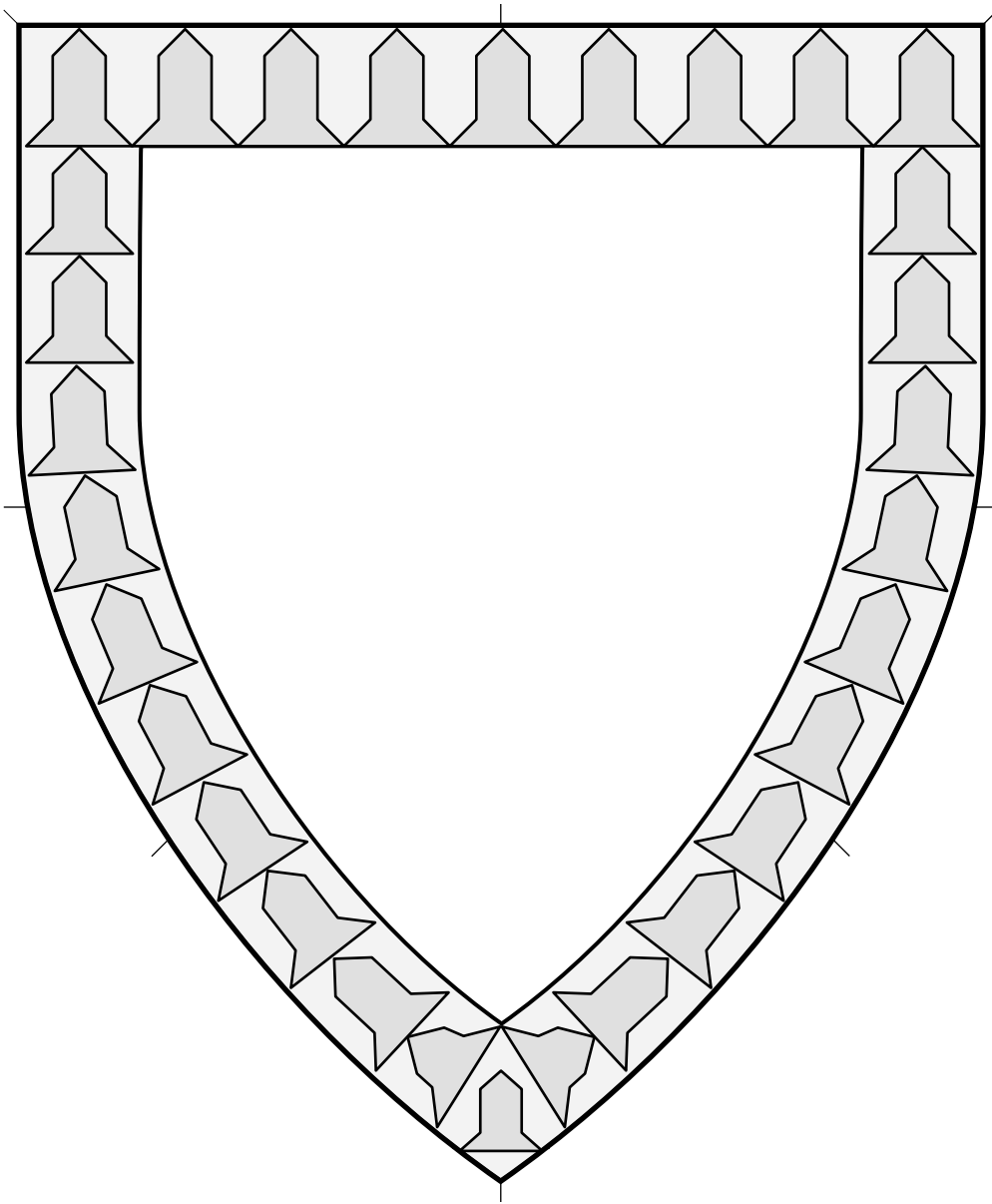

Peripheral ordinary.

Artist: Vémundr Syvursson. Adapted by Mathghamhain Ua Ruadháin.

Bordure Vair 4.196

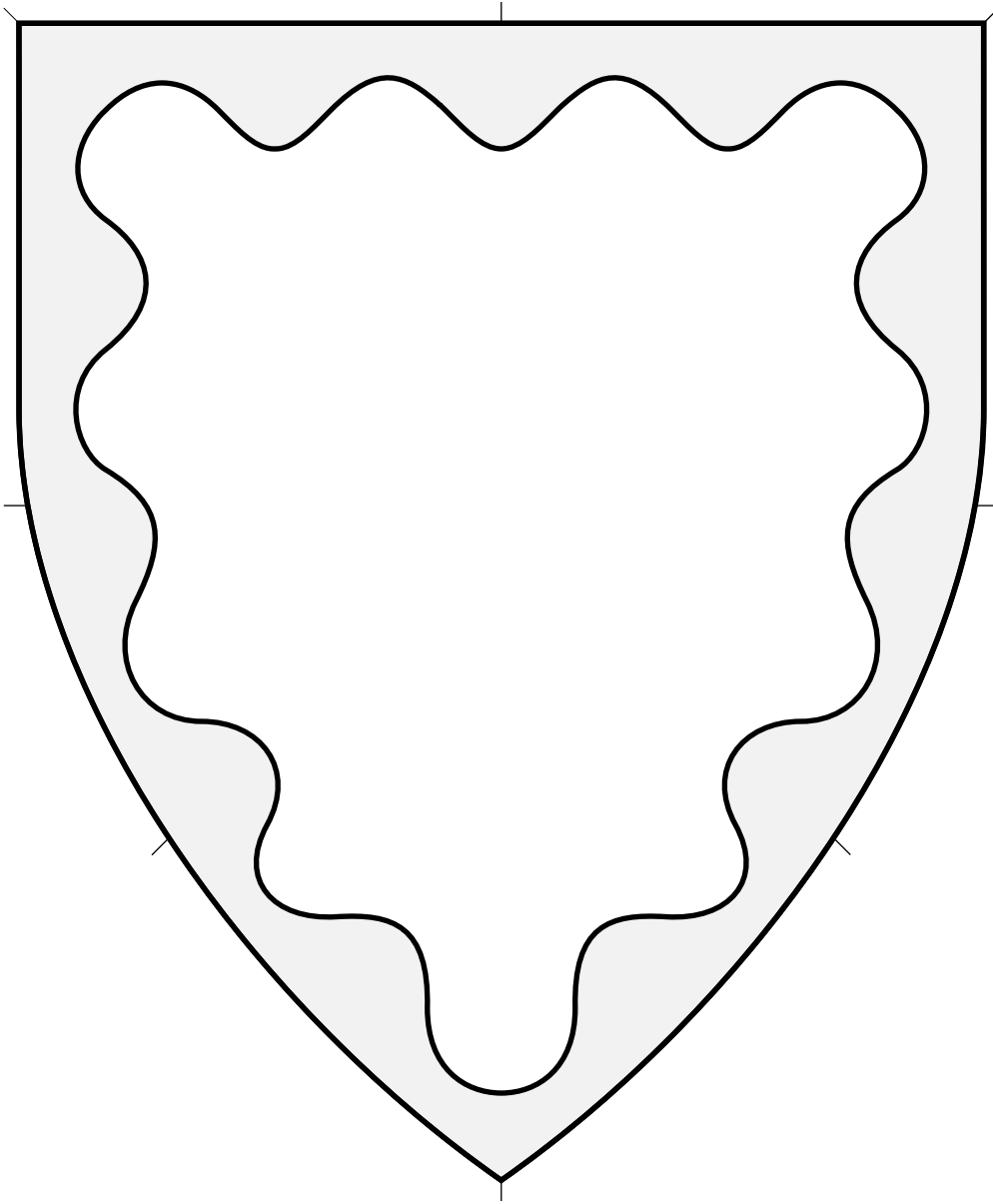

Peripheral ordinary.

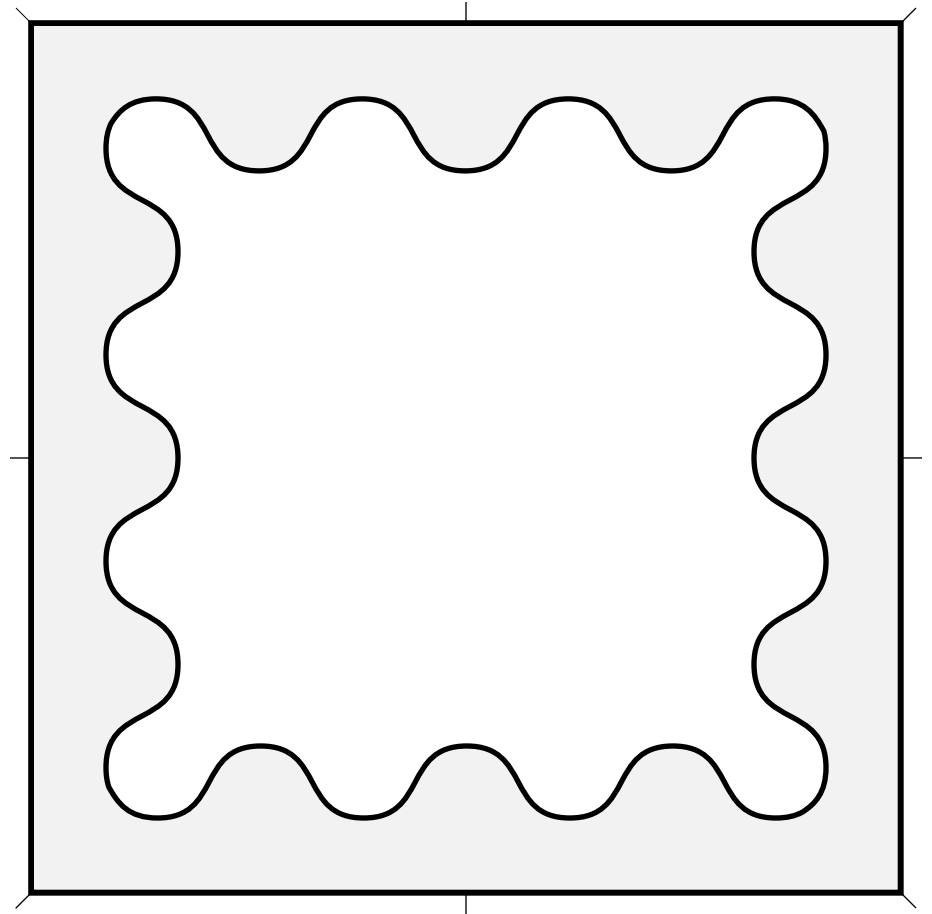

Bordure Wavy (1) 4.197

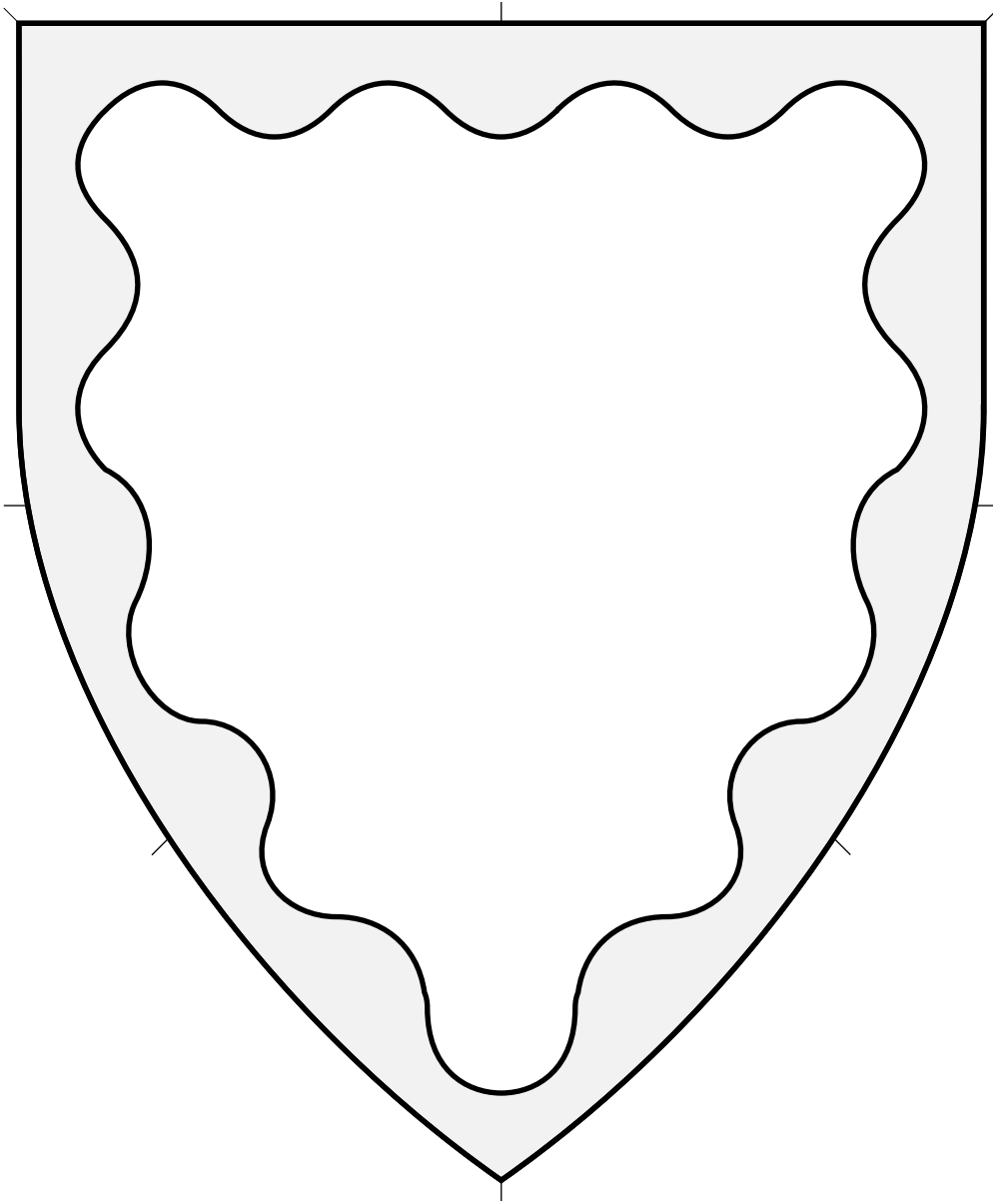

Peripheral ordinary.

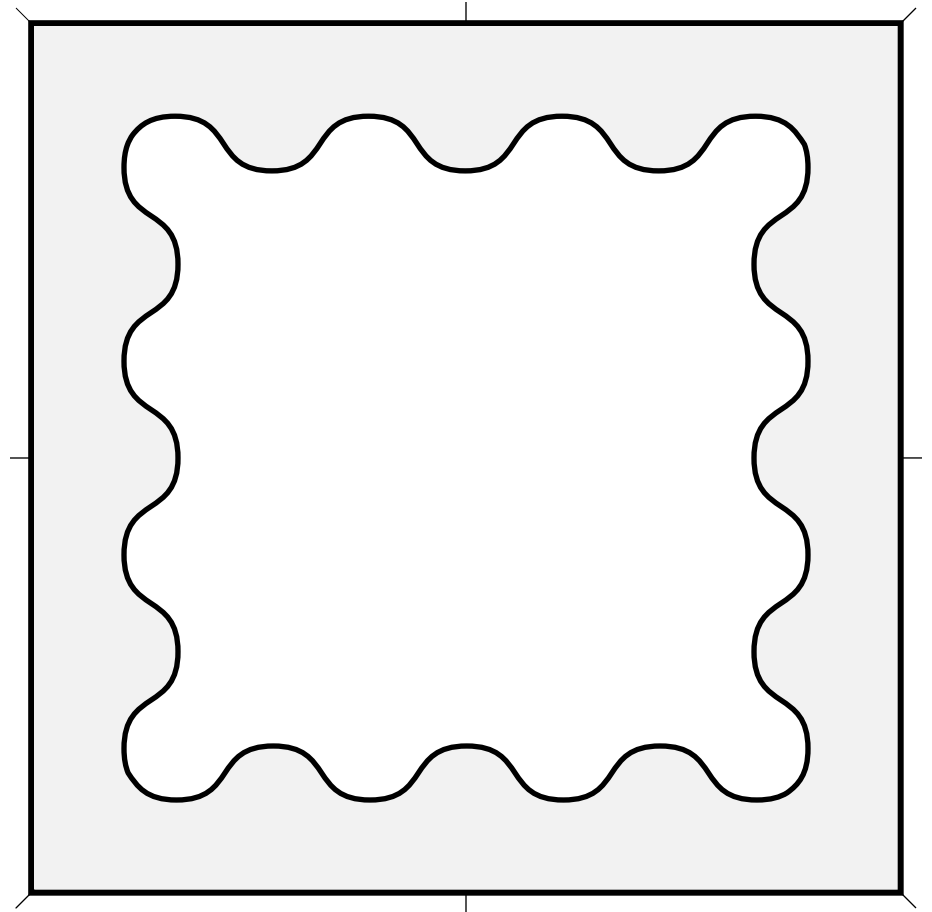

Bordure Wavy (2) 4.198

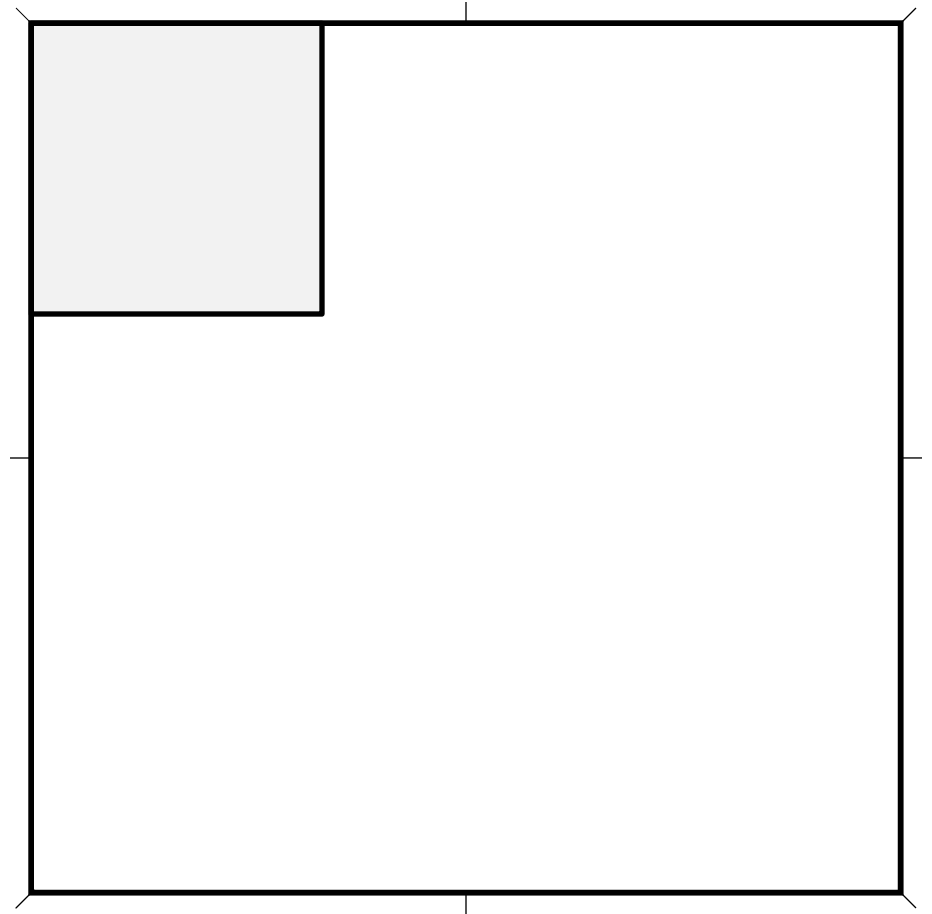
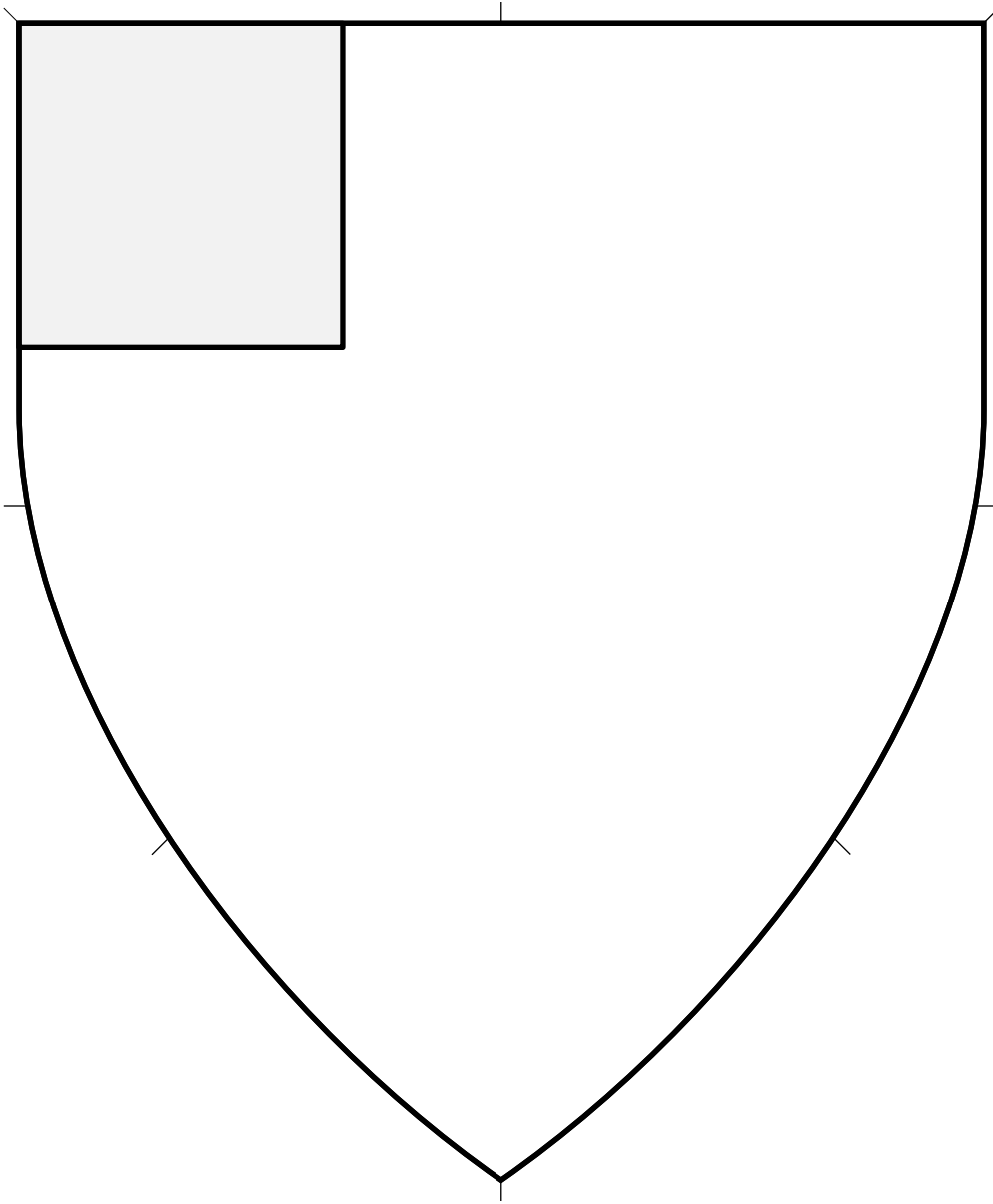

Peripheral ordinary. An upper corner of the device. Typically a third of the overall width but can be as large as a half.

Canton (1) 4.199

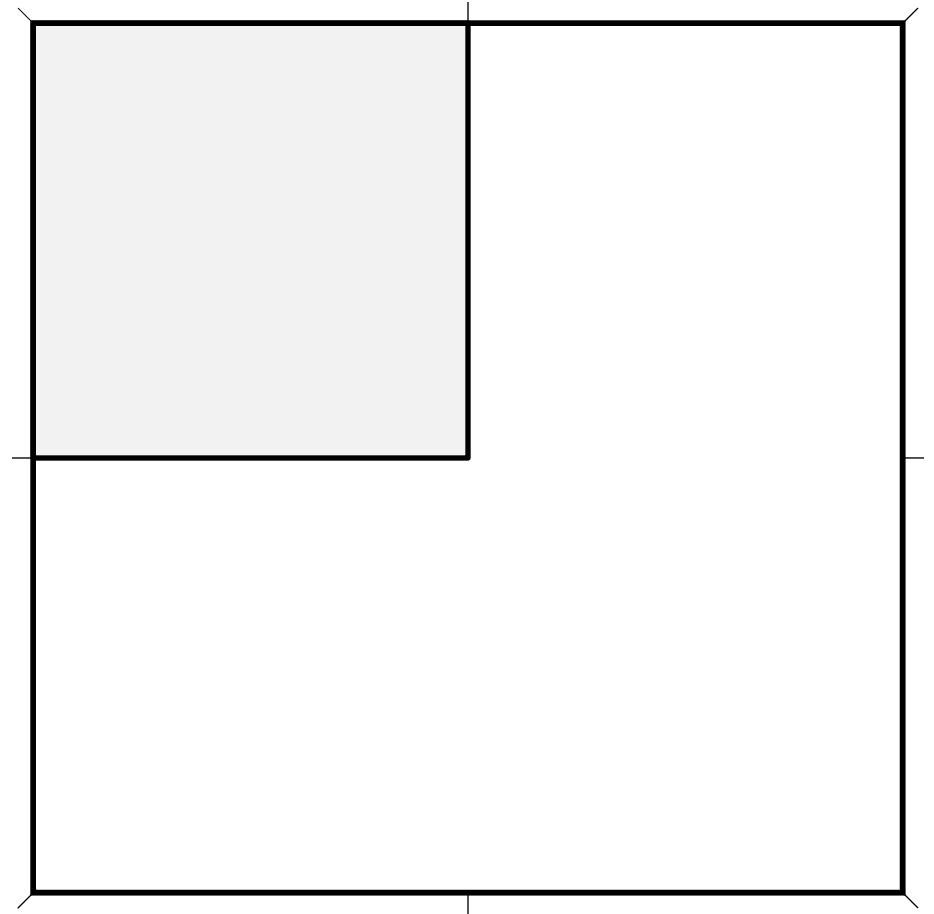
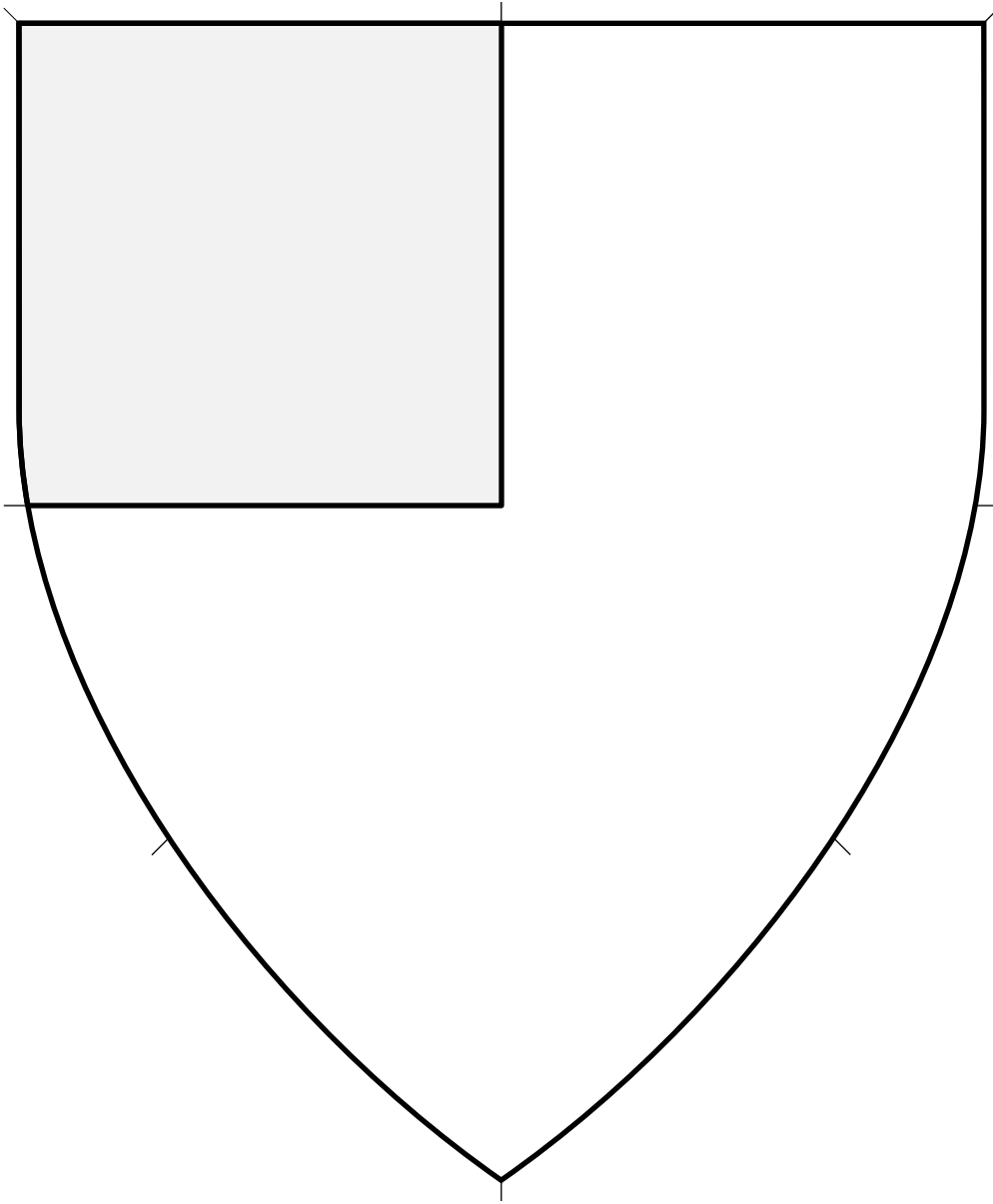

Peripheral ordinary. An upper corner of the device. Typically a third of the overall width but can be as large as a half. A larger canton such as this is sometimes blazoned a “quarter.”

Canton (2) 4.200

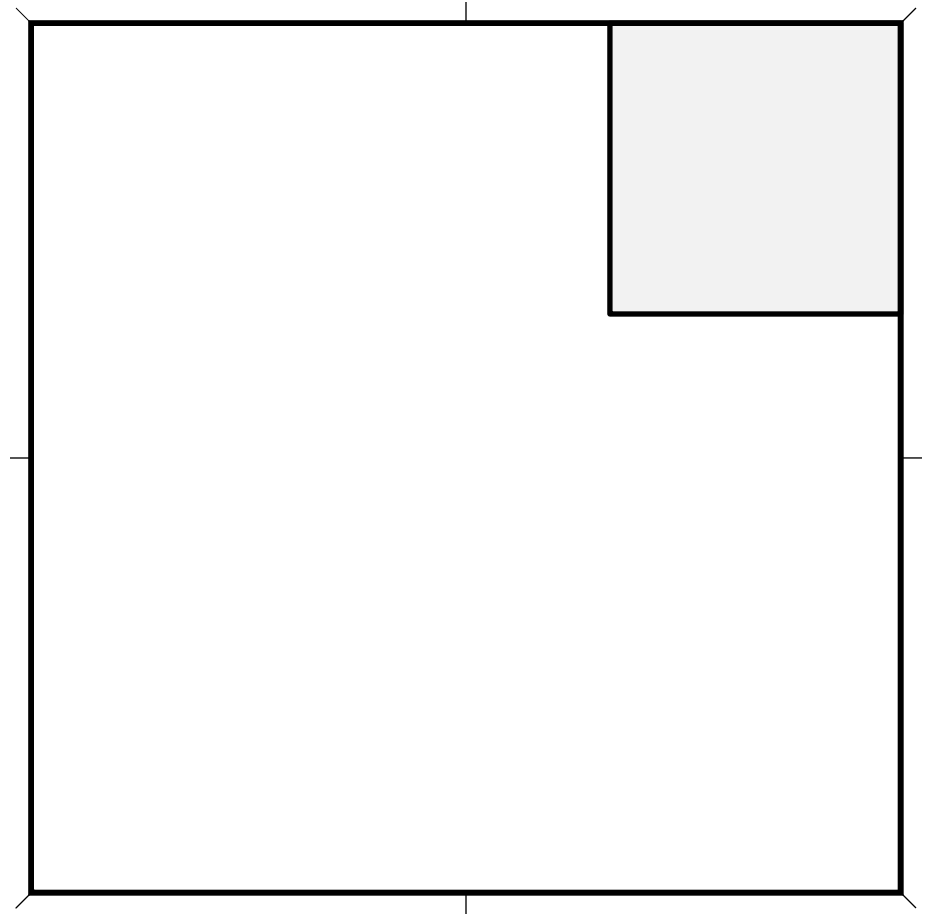
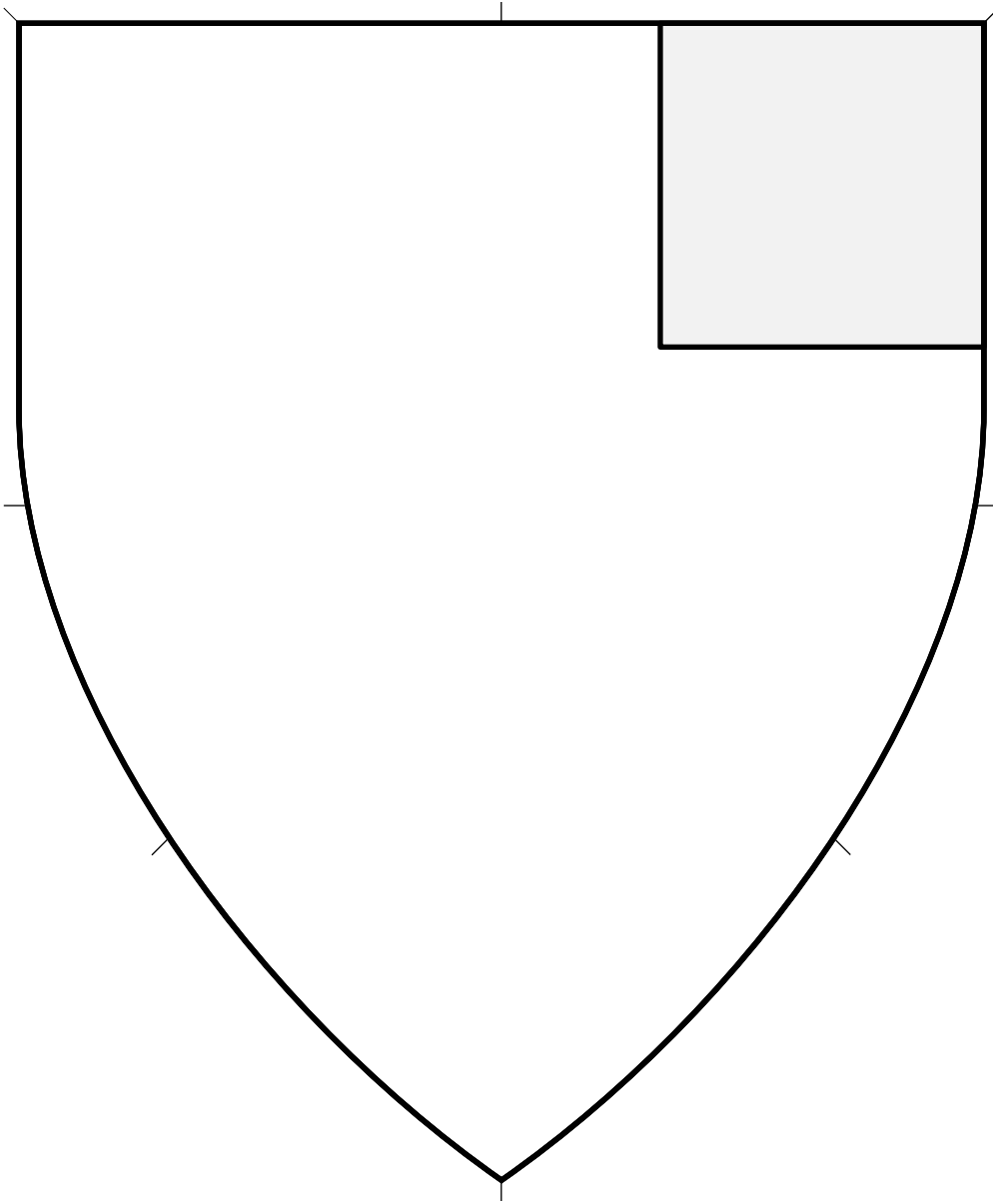

Peripheral ordinary. An upper corner of the device. Typically a third of the overall width but can be as large as a half.

Canton, Sinister (1) 4.201

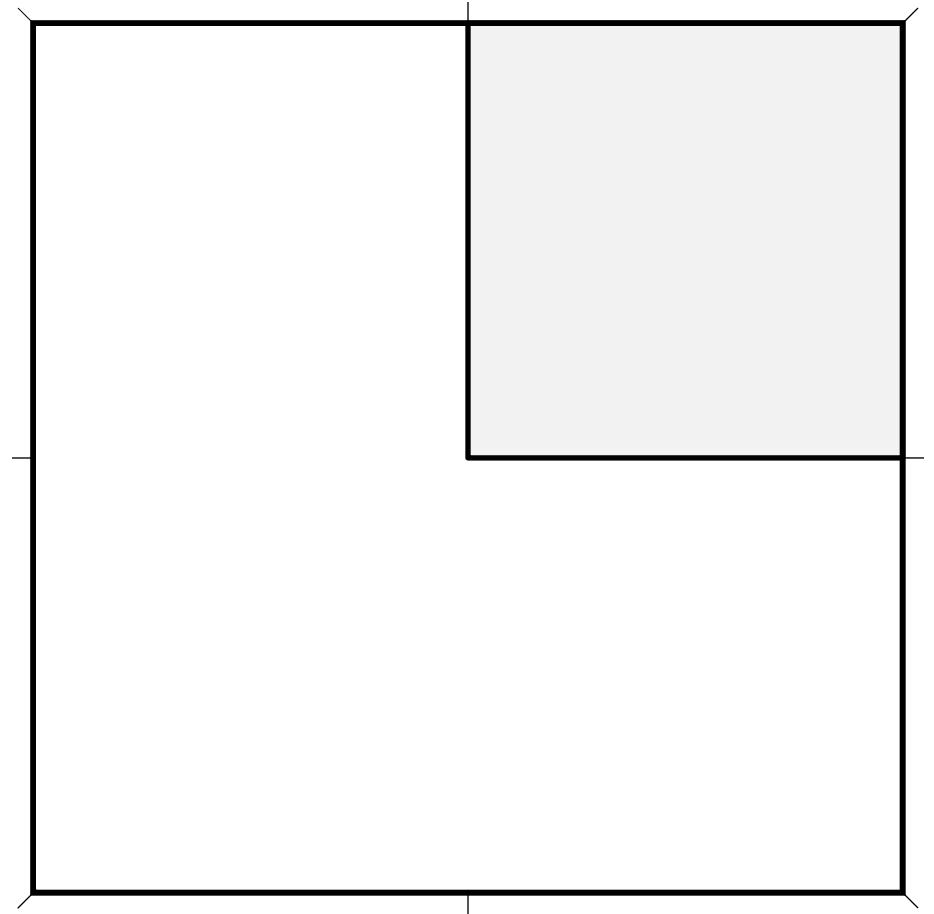
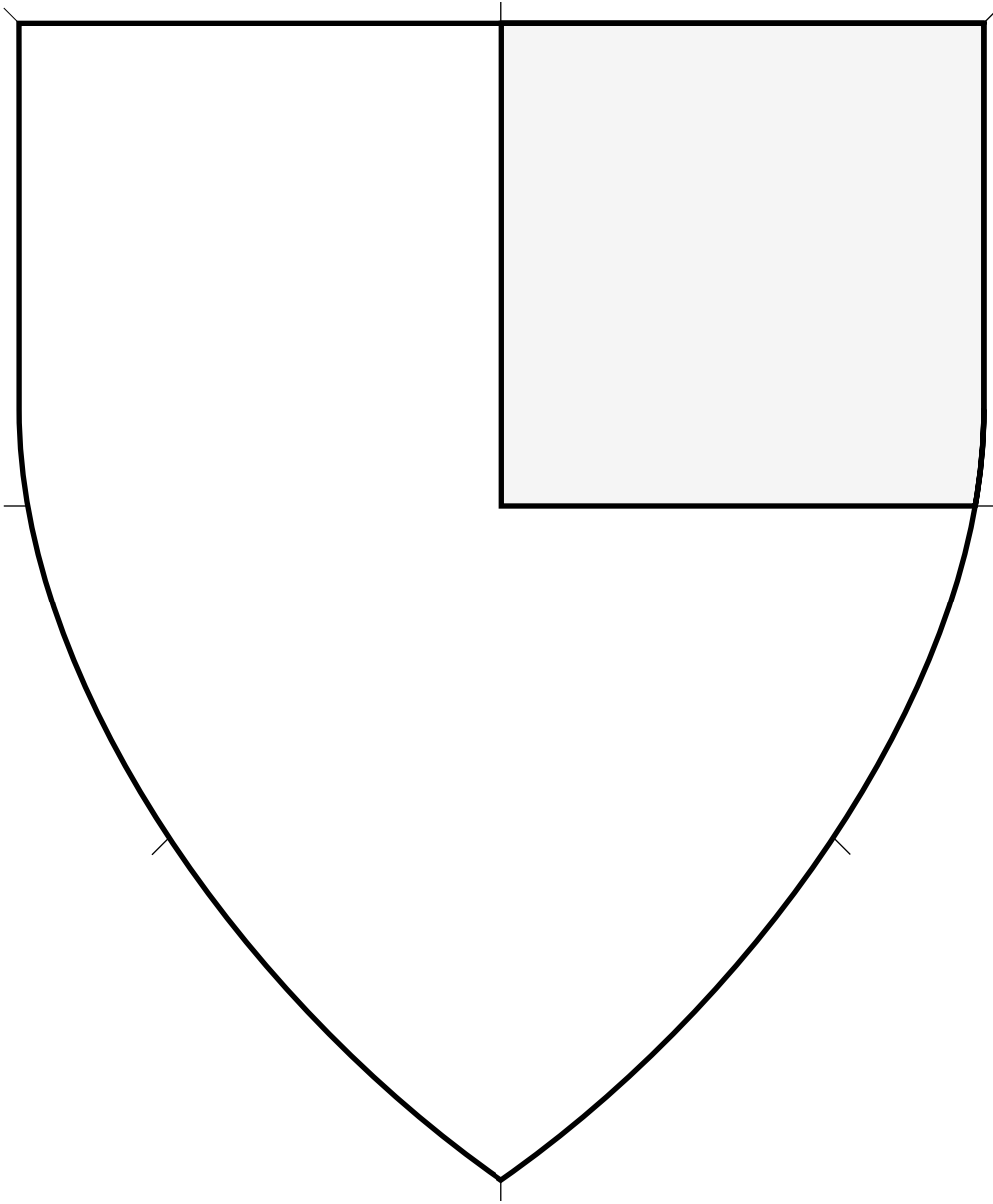

Peripheral ordinary. An upper corner of the device. Typically a third of the overall width but can be as large as a half. A larger canton such as this is sometimes blazoned a “quarter.”

Canton, Sinister (2) • 4.202

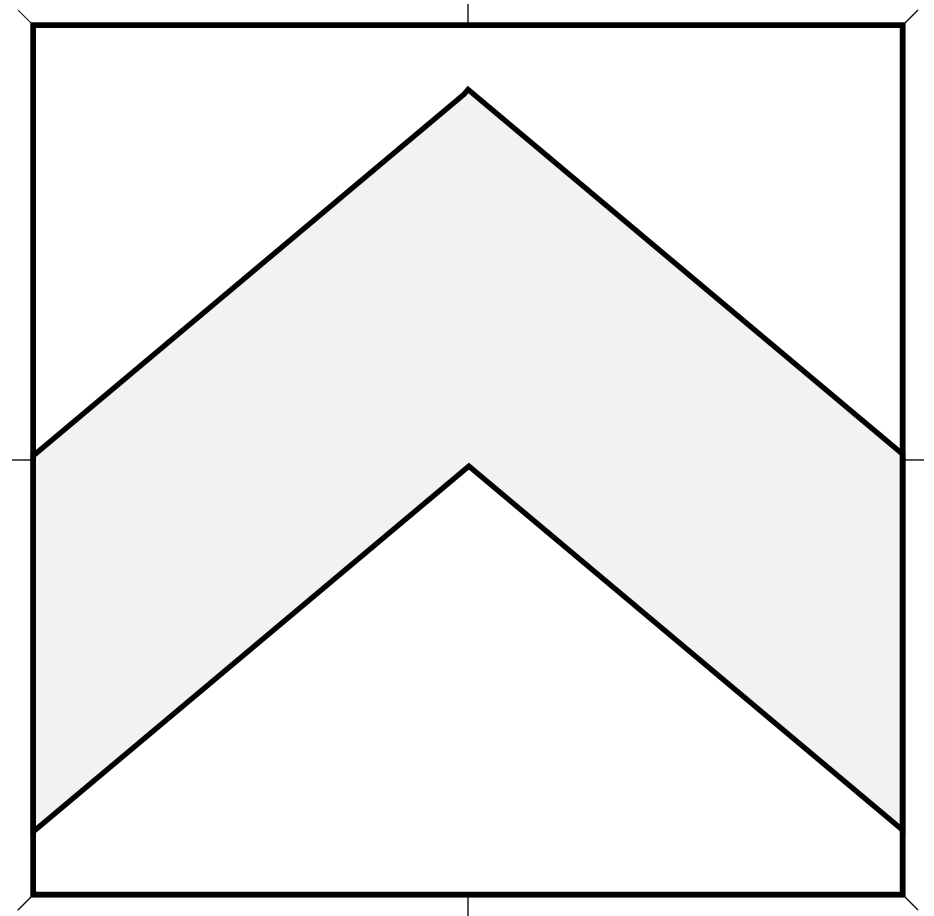
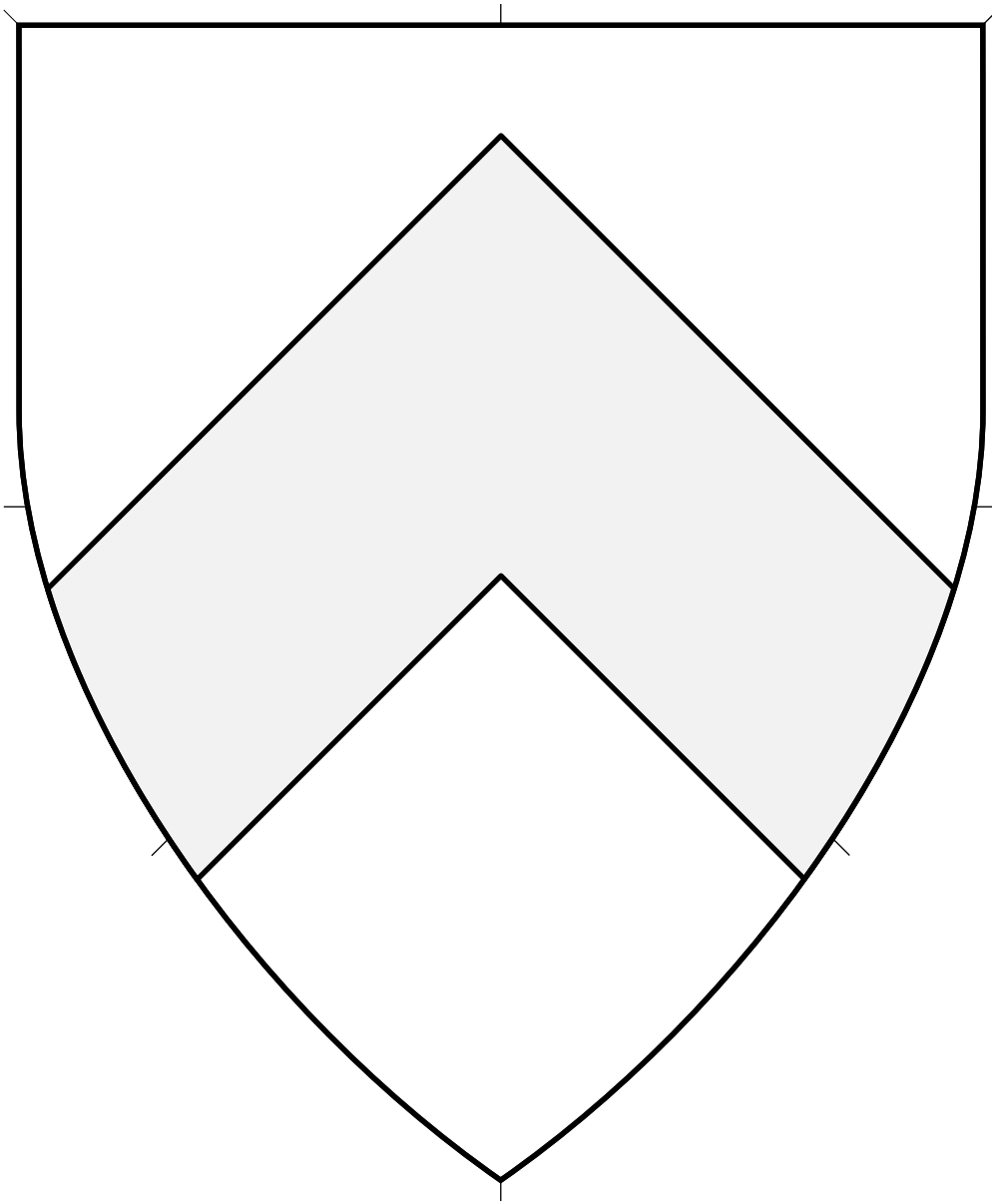

Central ordinary. Must issue from sides of device. Must be centered on the fess line, except if shifted up or down to accommodate secondary charges. Angle may be narrower or wider than 90° . The thickness of each arm is typically between a third to a fifth of the width of the device. This is a thick chevron suitable for bearing charges.

Chevron (1) • 4.203

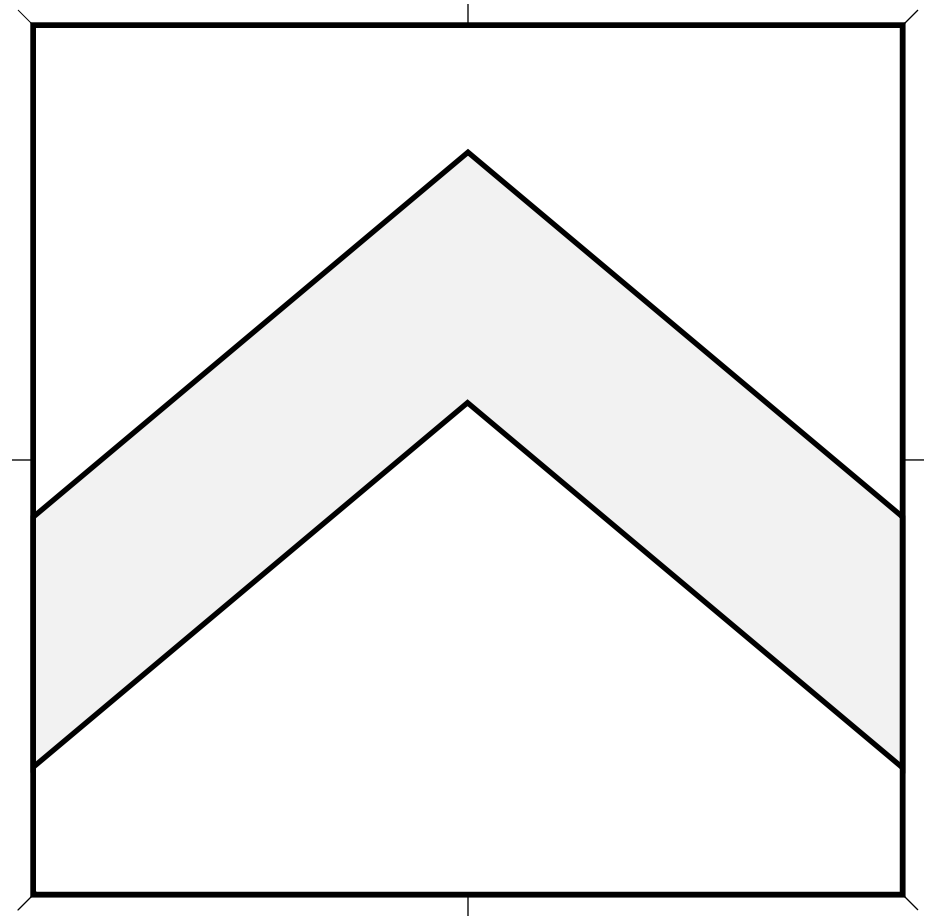
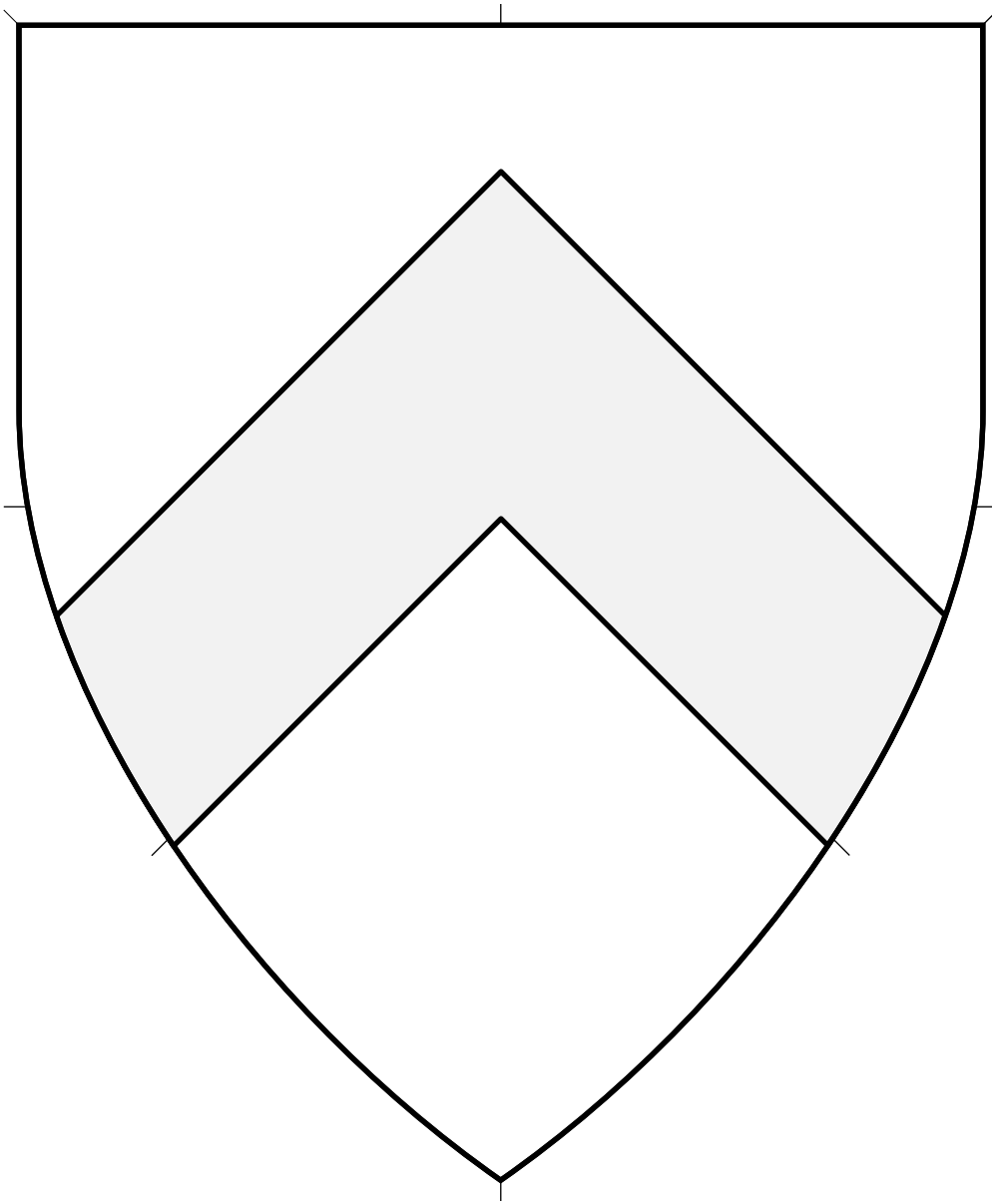

Central ordinary. Must issue from sides of device. Must be centered on the fess line, except if shifted up or down to accommodate secondary charges. Angle may be narrower or wider than 90°. The thickness of each arm is typically between a third to a fifth of the width of the device. This is a medium-width chevron.

Chevron (2) 4.204

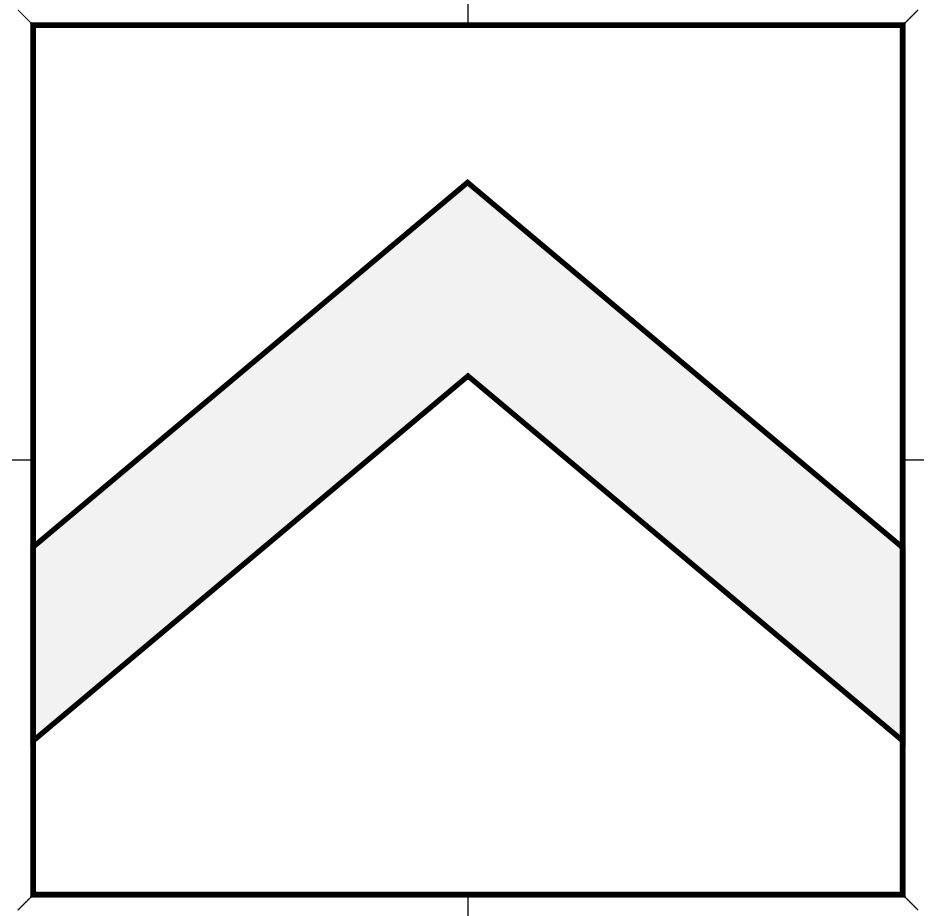
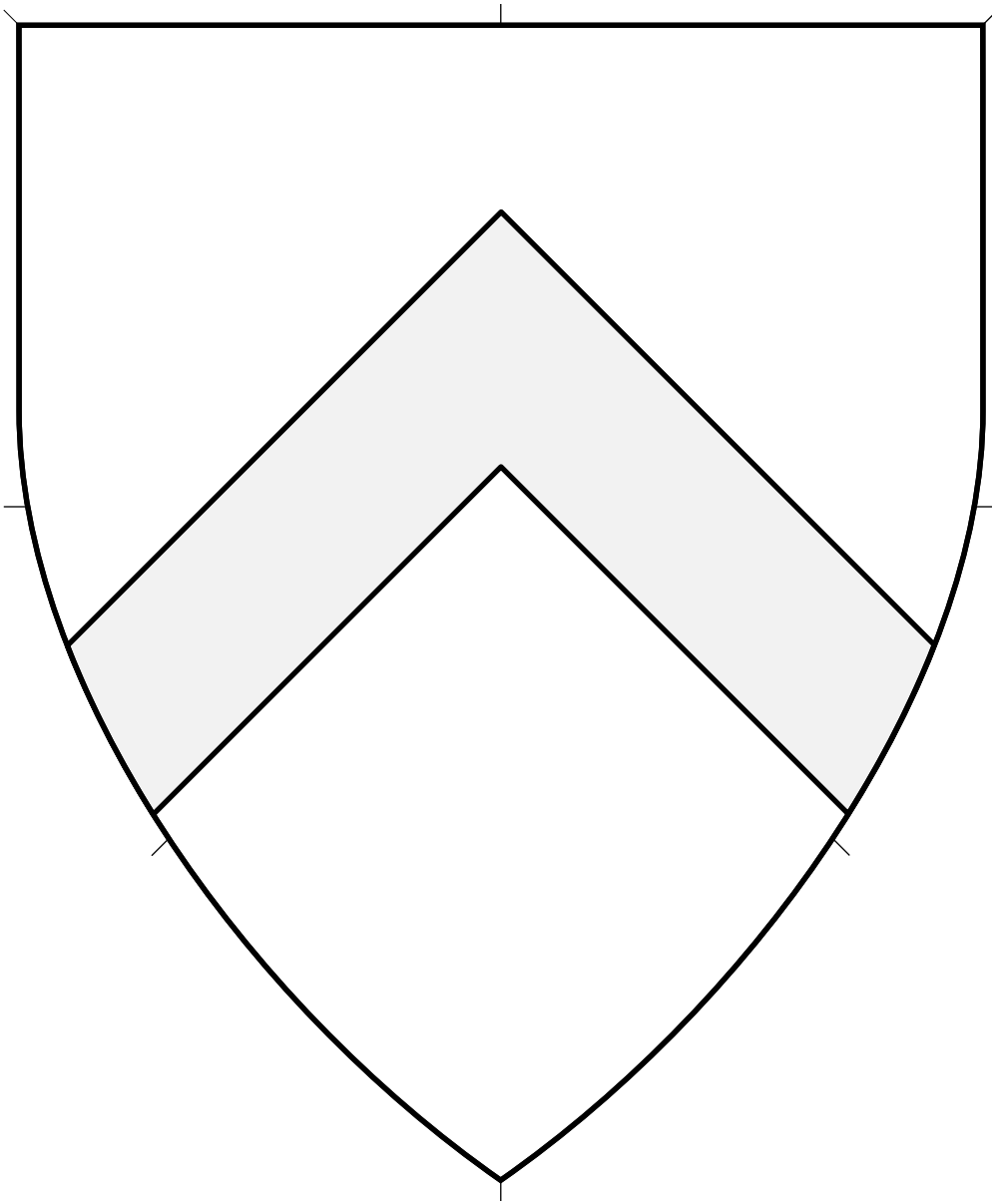

Central ordinary. Must issue from sides of device. Must be centered on the fess line, except if shifted up or down to accommodate secondary charges. Angle may be narrower or wider than 90°. The thickness of each arm is typically between a third to a fifth of the width of the device. This is a skinny chevron.

Chevron (3) • 4.205

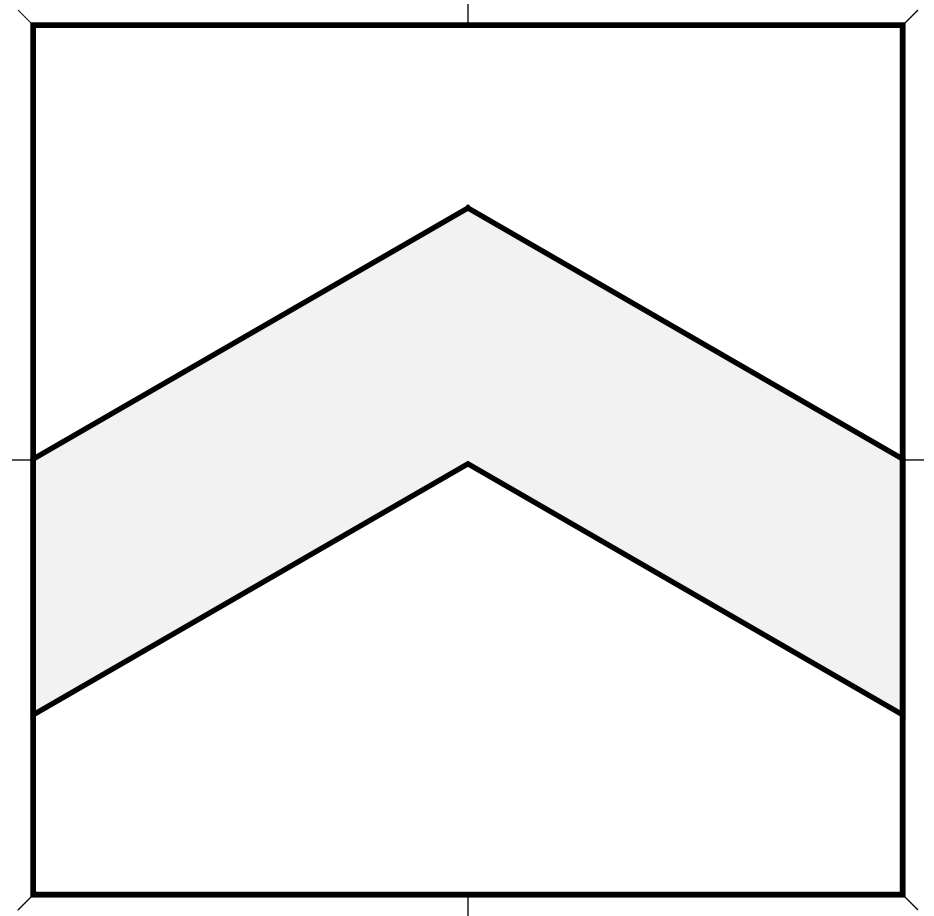
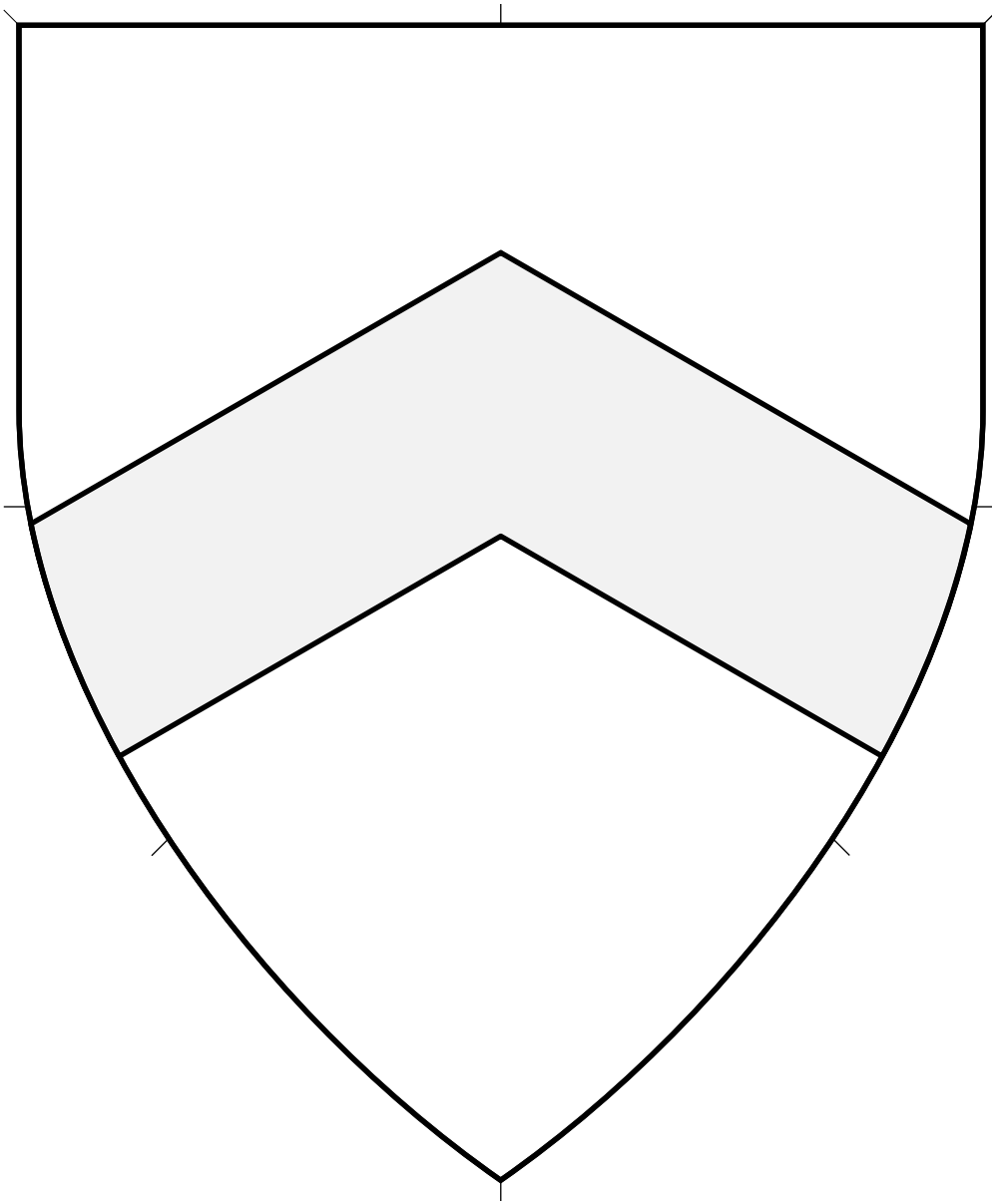

Central ordinary. Must issue from sides of device. Must be centered on the fess line, except if shifted up or down to accommodate secondary charges. Angle may be narrower or wider than 90° . The thickness of each arm is typically between a third to a fifth of the width of the device. This is a flatter chevron.

Chevron (4) • 4.206

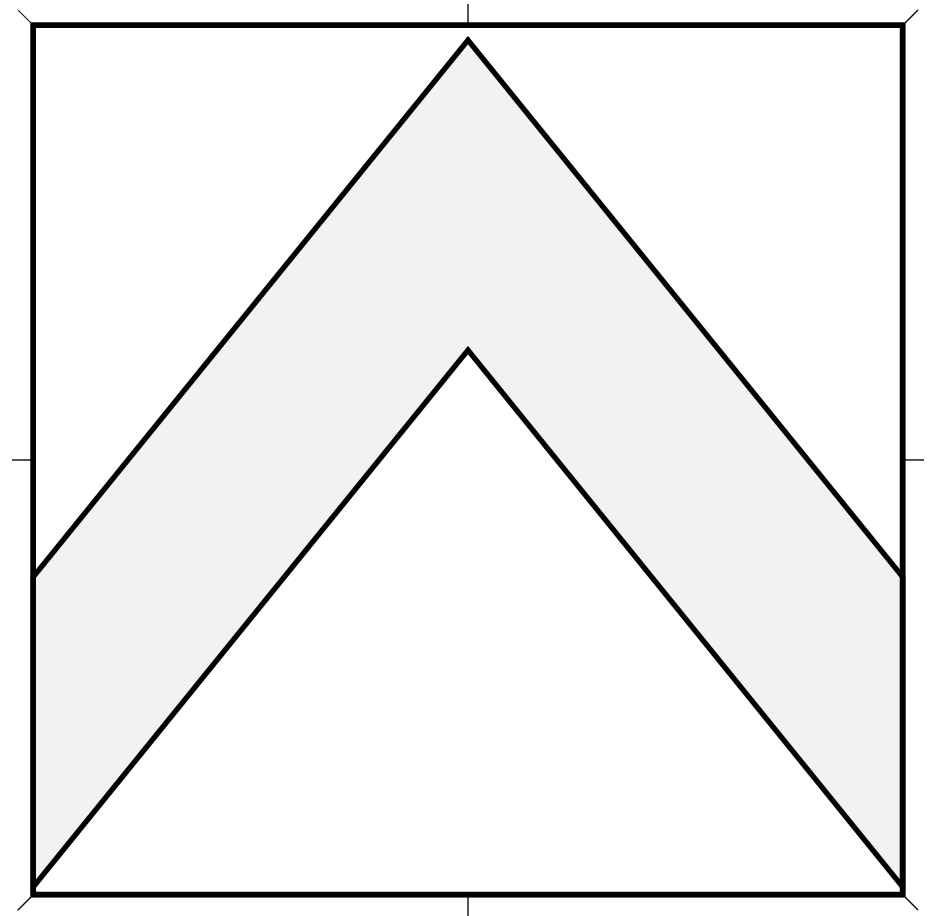
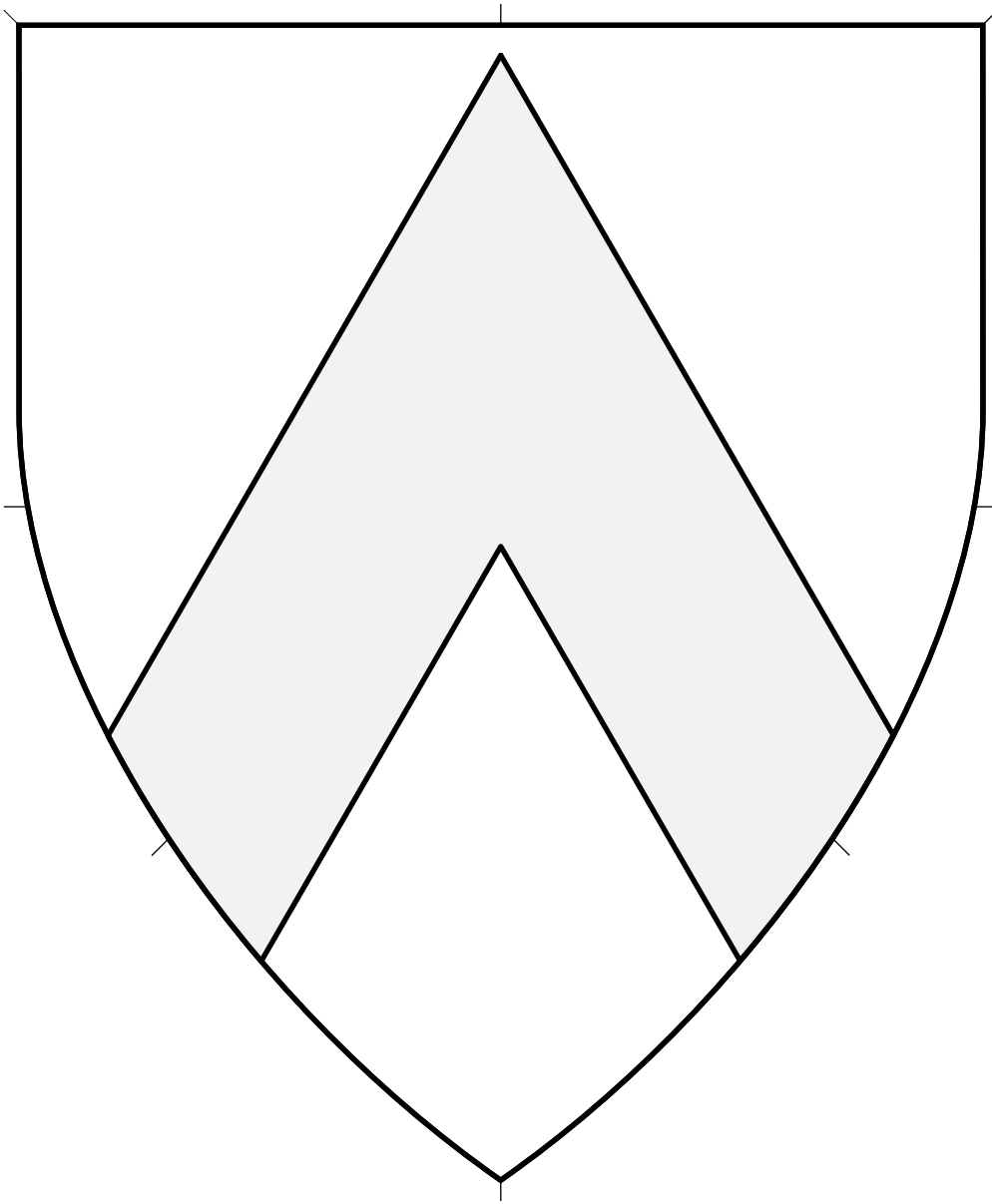

Central ordinary. Must issue from sides of device. Must be centered on the fess line, except if shifted up or down to accommodate secondary charges. Angle may be narrower or wider than 90° . The thickness of each arm is typically between a third to a fifth of the width of the device. This is a steeper chevron.

Chevron (5) • 4.207

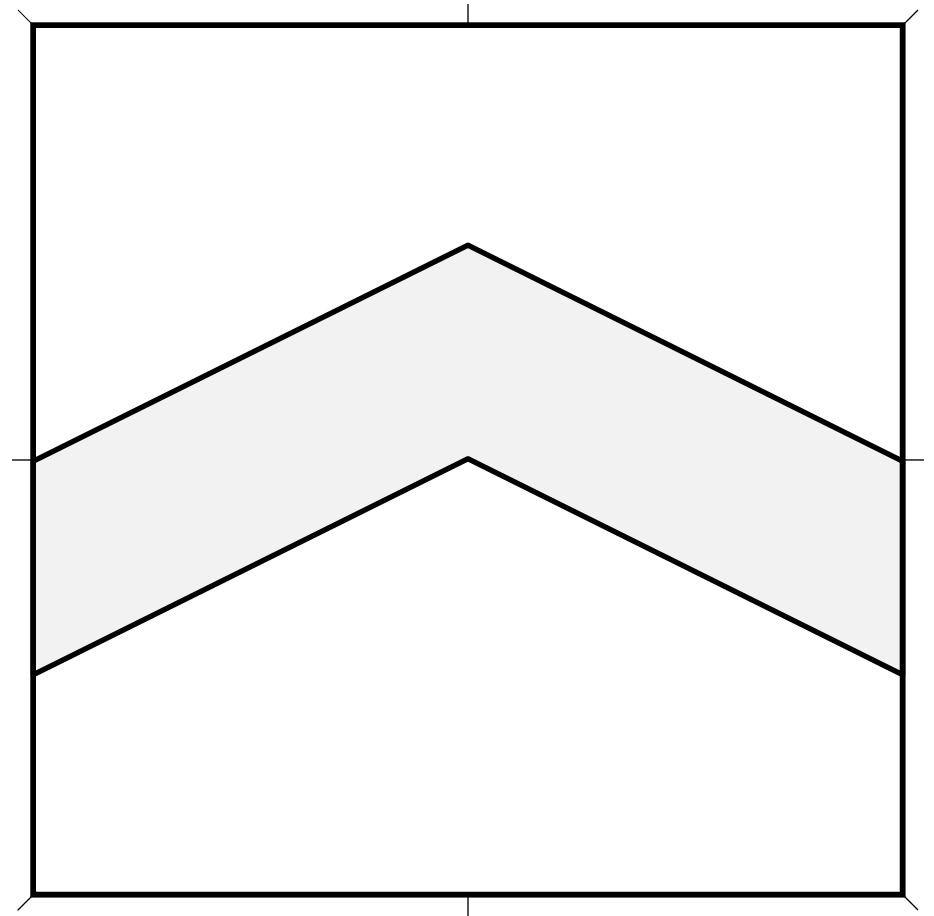
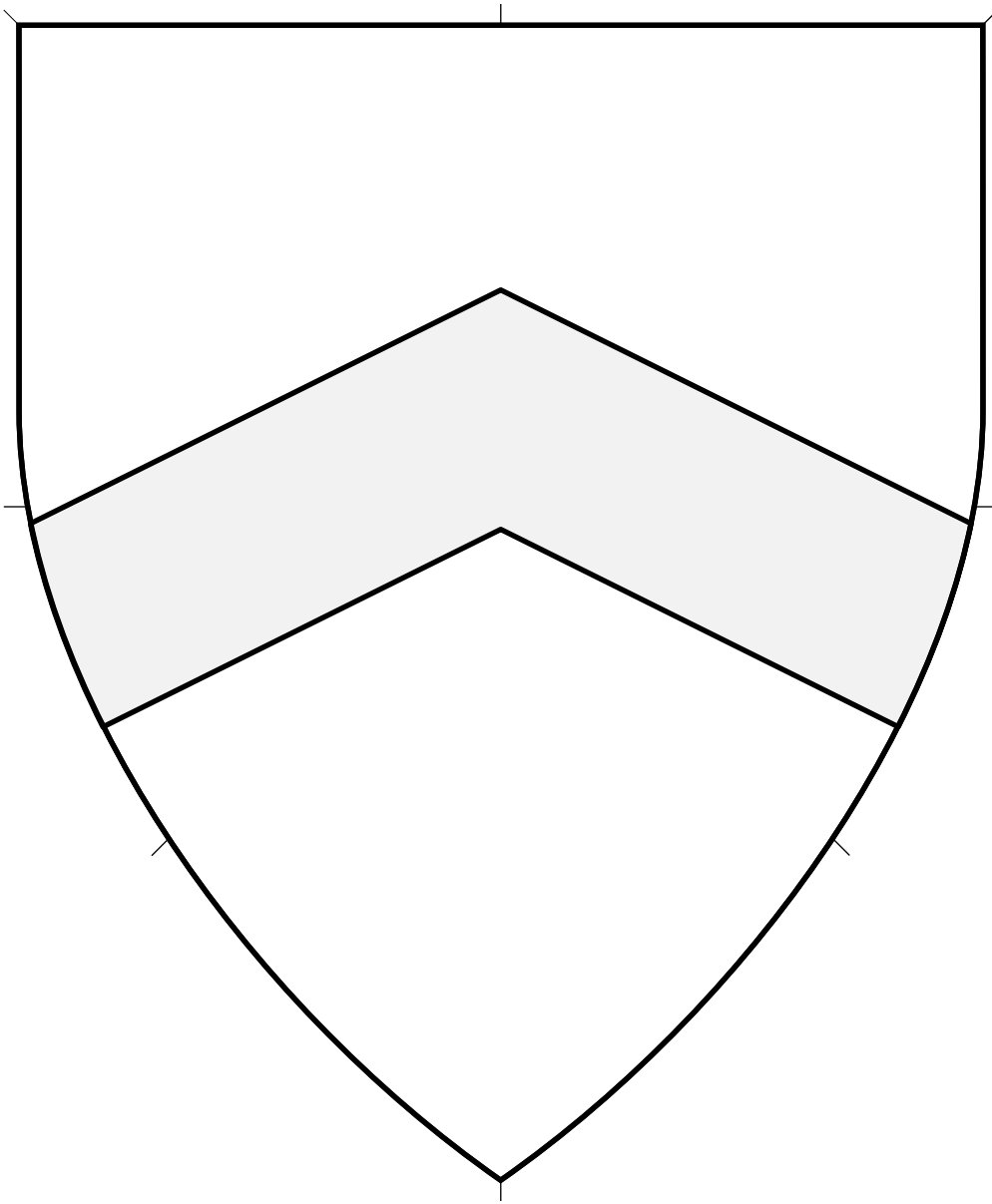

Central ordinary. Must issue from sides of device. Must be centered on the fess line, except if shifted up or down to accommodate secondary charges. Angle may be narrower or wider than 90° . The thickness of each arm is typically between a third to a fifth of the width of the device. This is a flatter chevron.

Chevron (6) 4.208

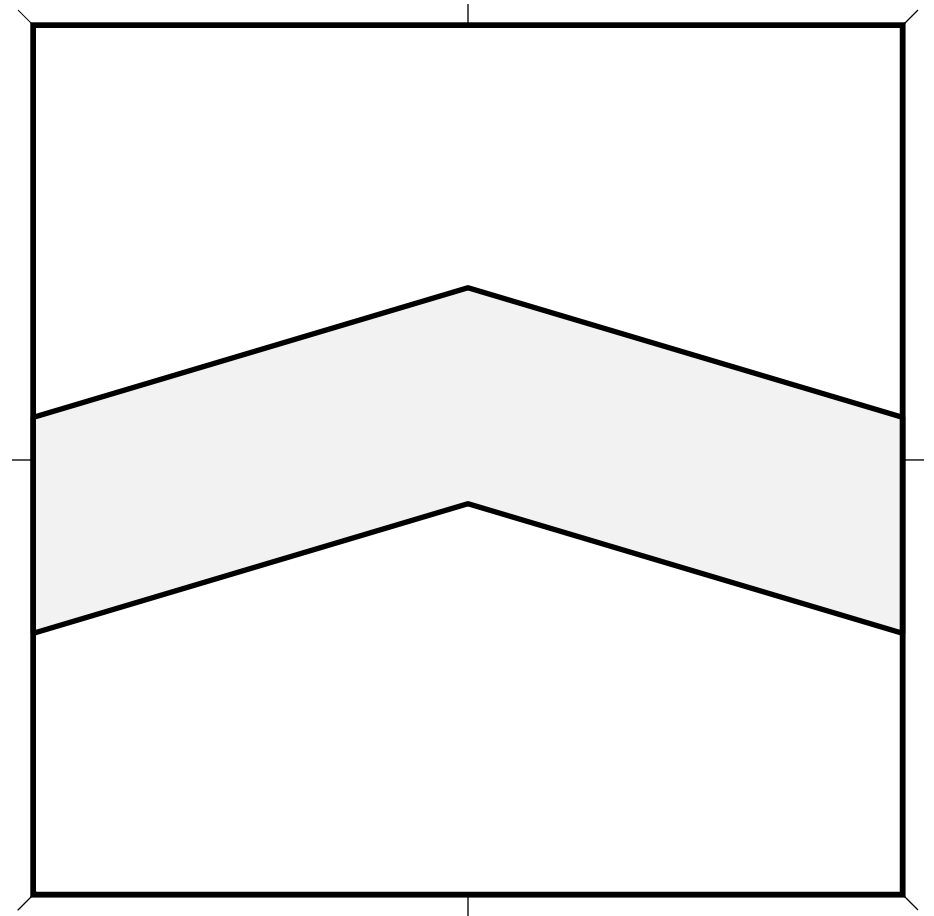
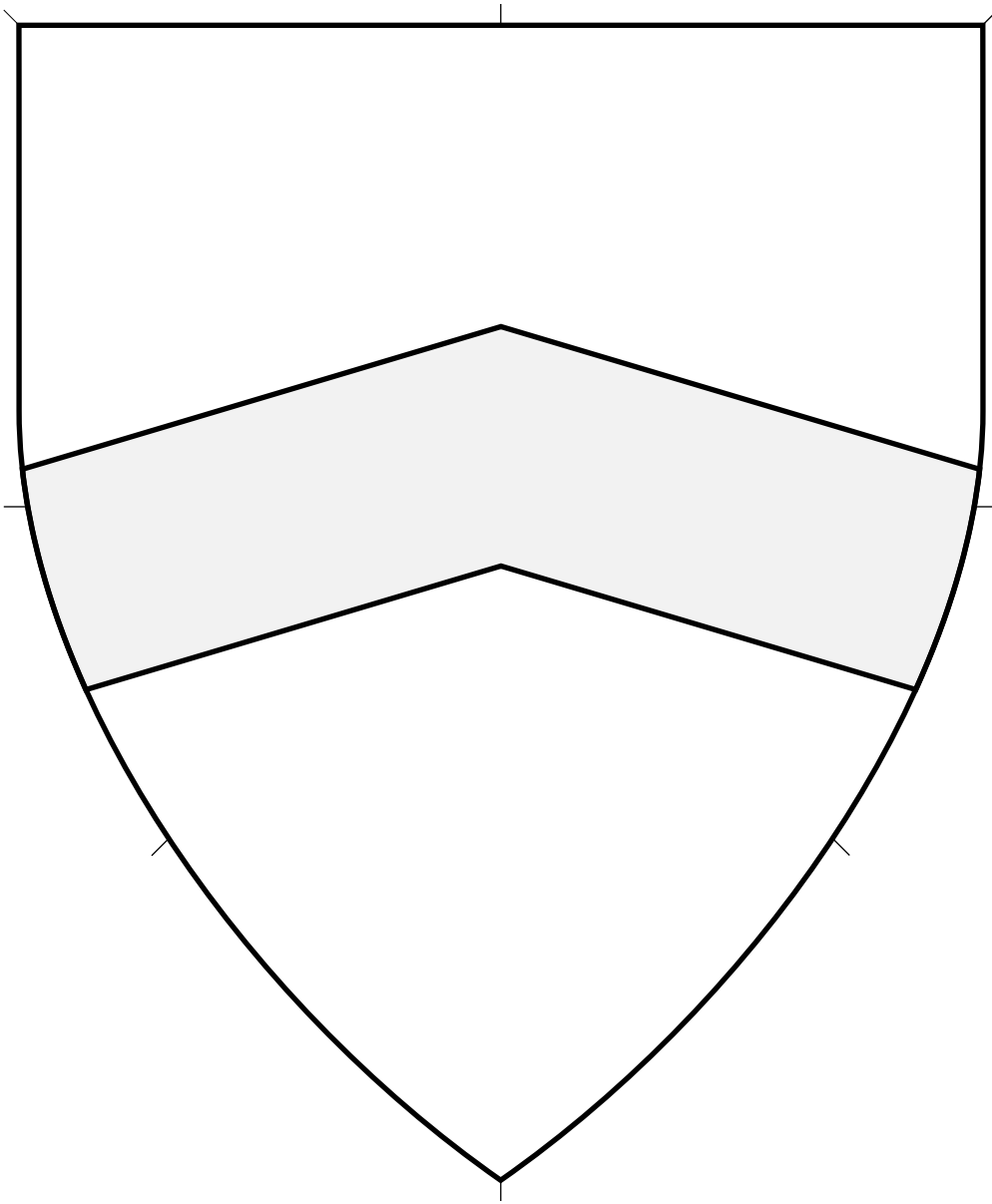

Central ordinary. Must issue from sides of device. Must be centered on the fess line, except if shifted up or down to accommodate secondary charges. Angle may be narrower or wider than 90° . The thickness of each arm is typically between a third to a fifth of the width of the device. This is a flatter chevron.

Chevron (7) • 4.209

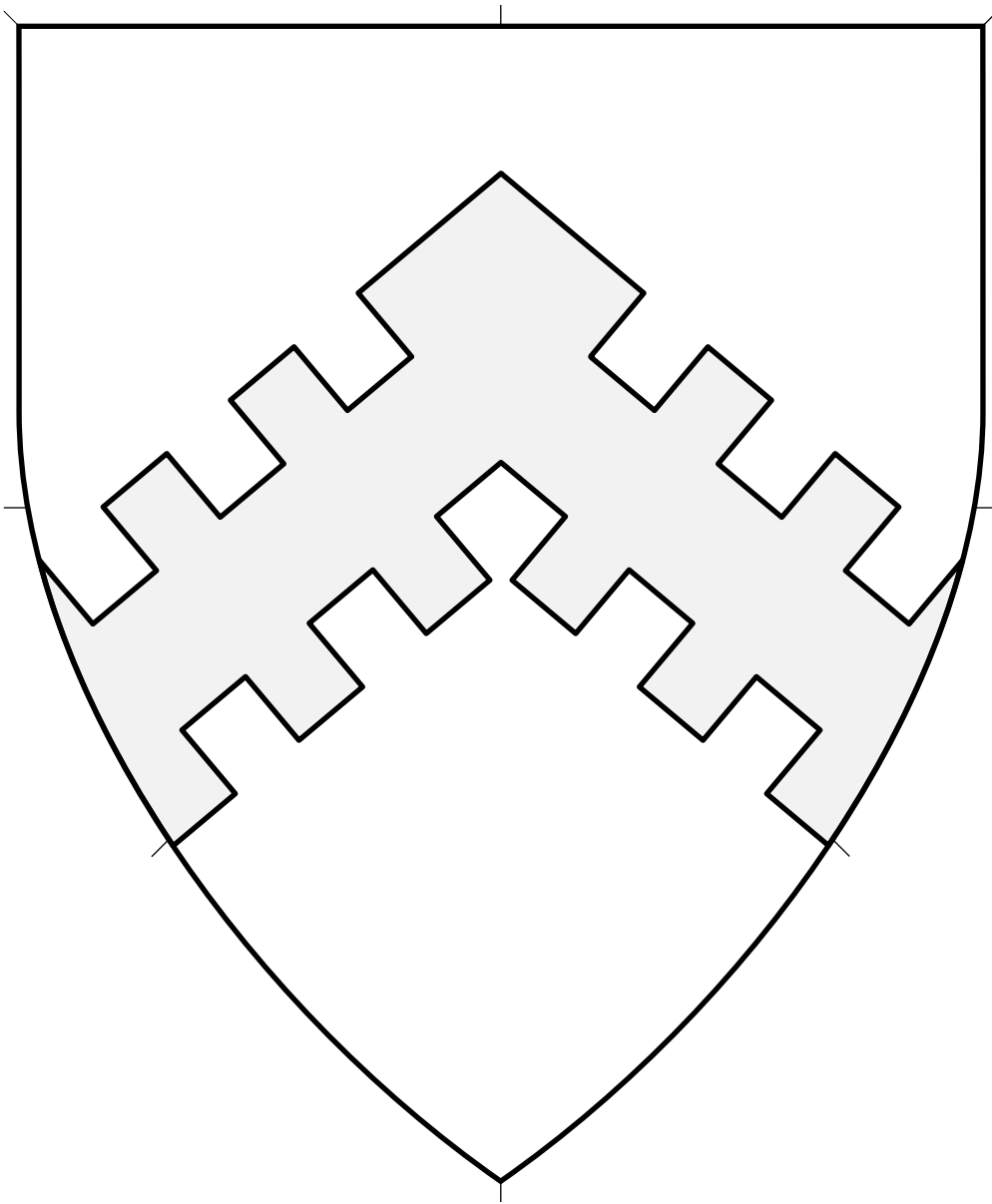

Central ordinary.

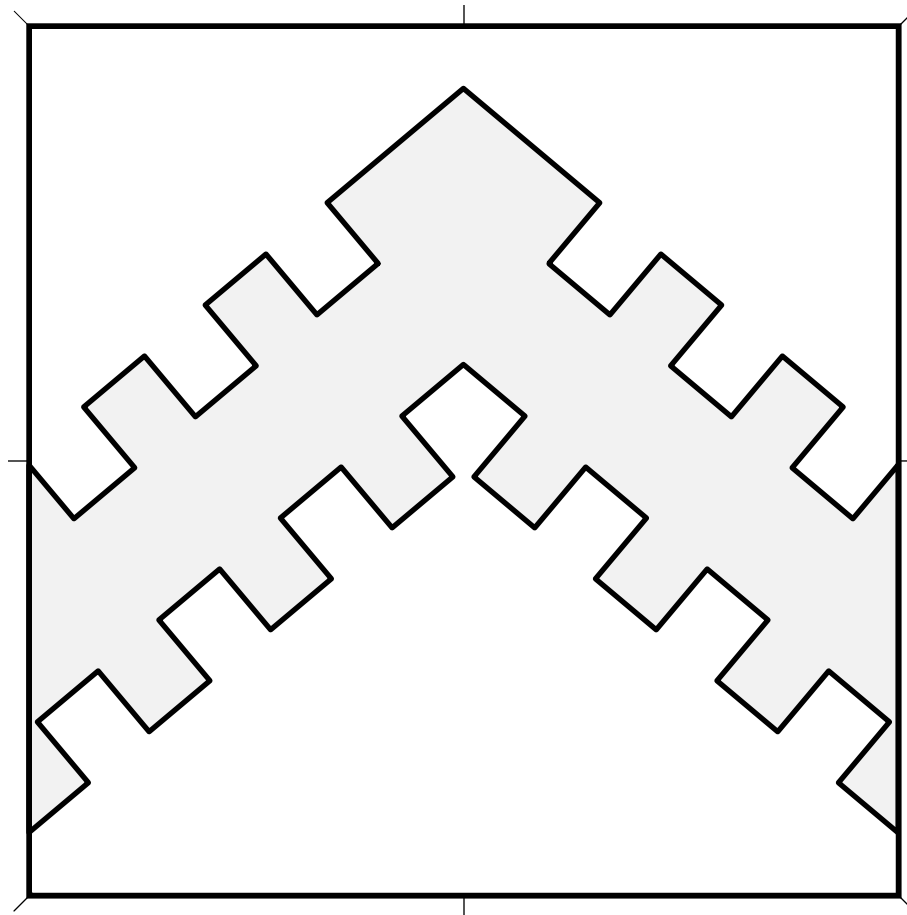

Chevron Breasted (1) 4.210

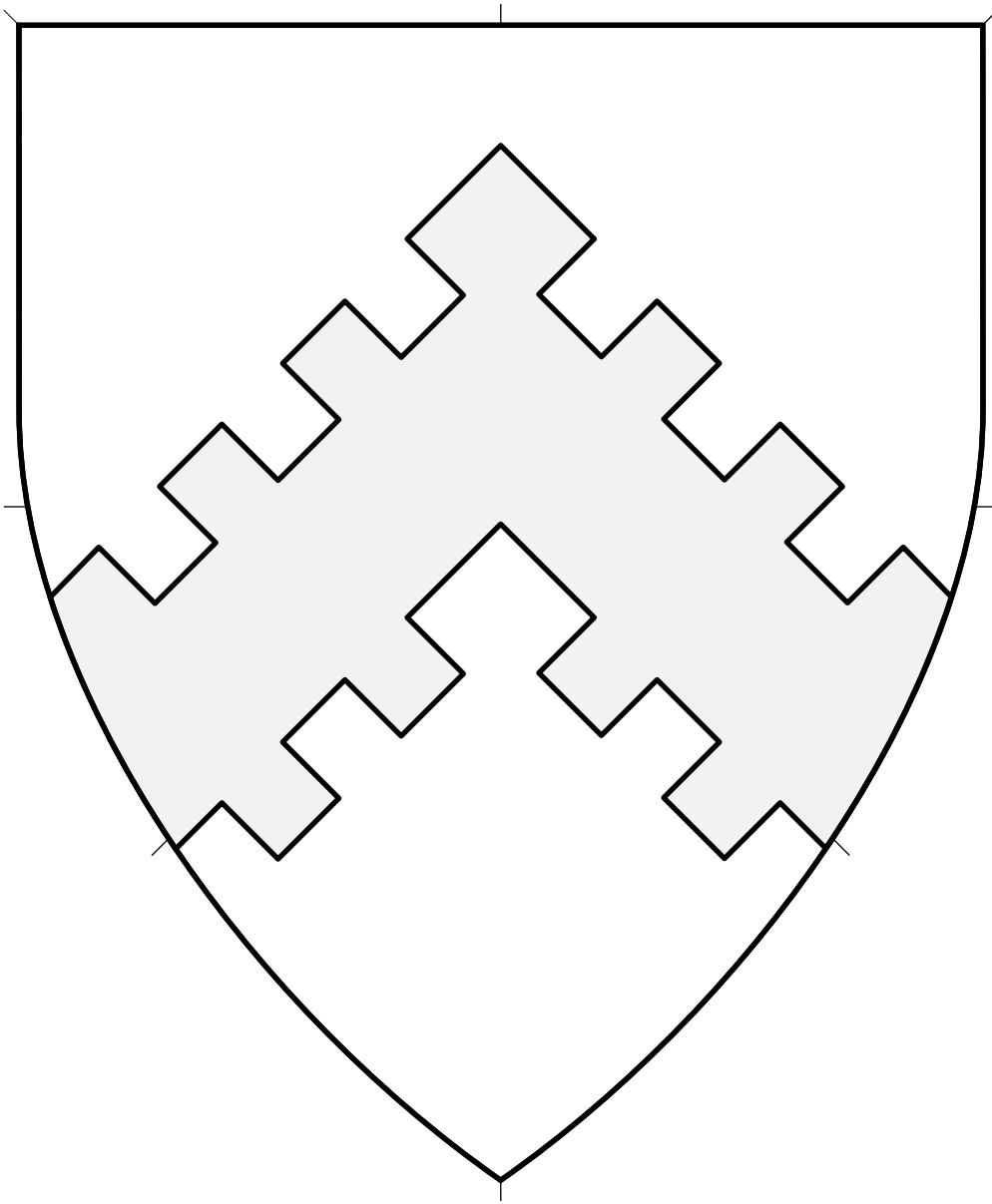

Central ordinary.

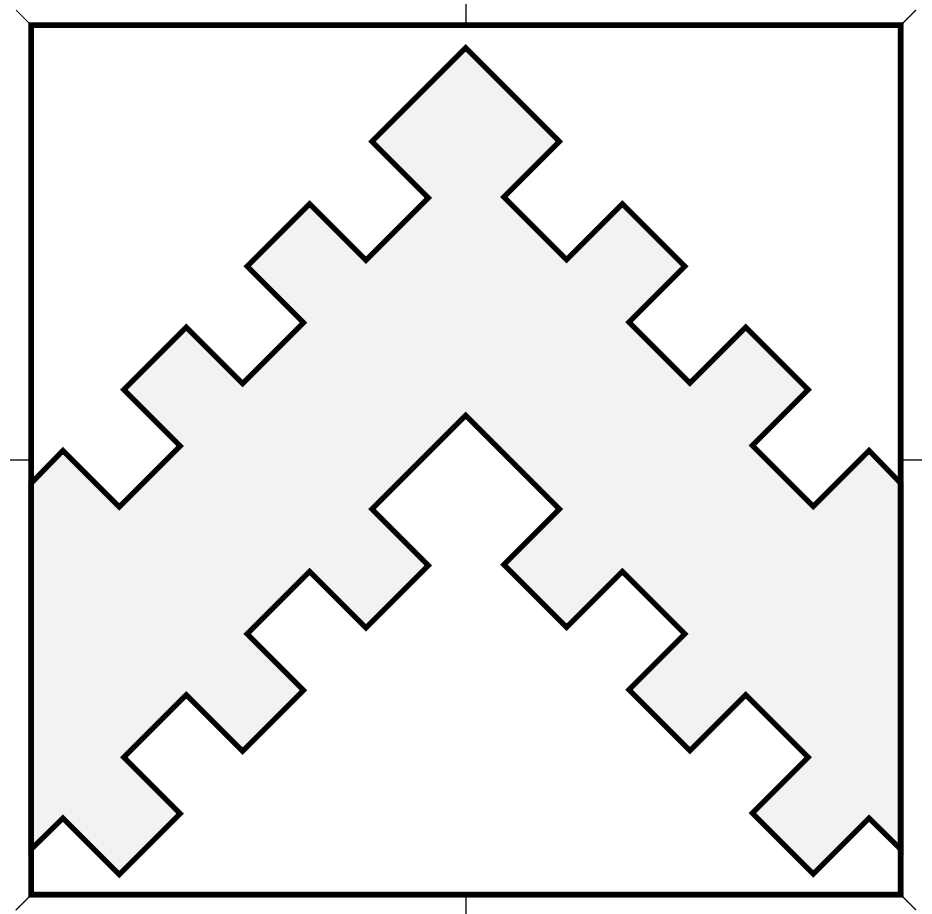

Chevron Breressed (2) 4.211

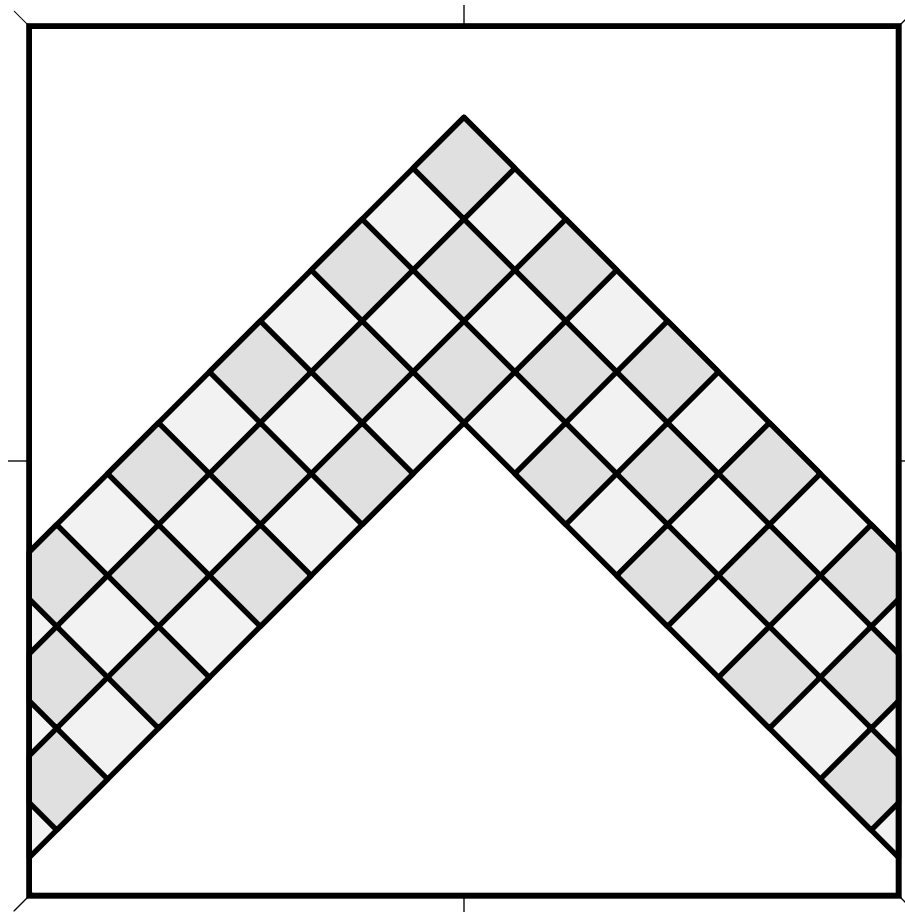
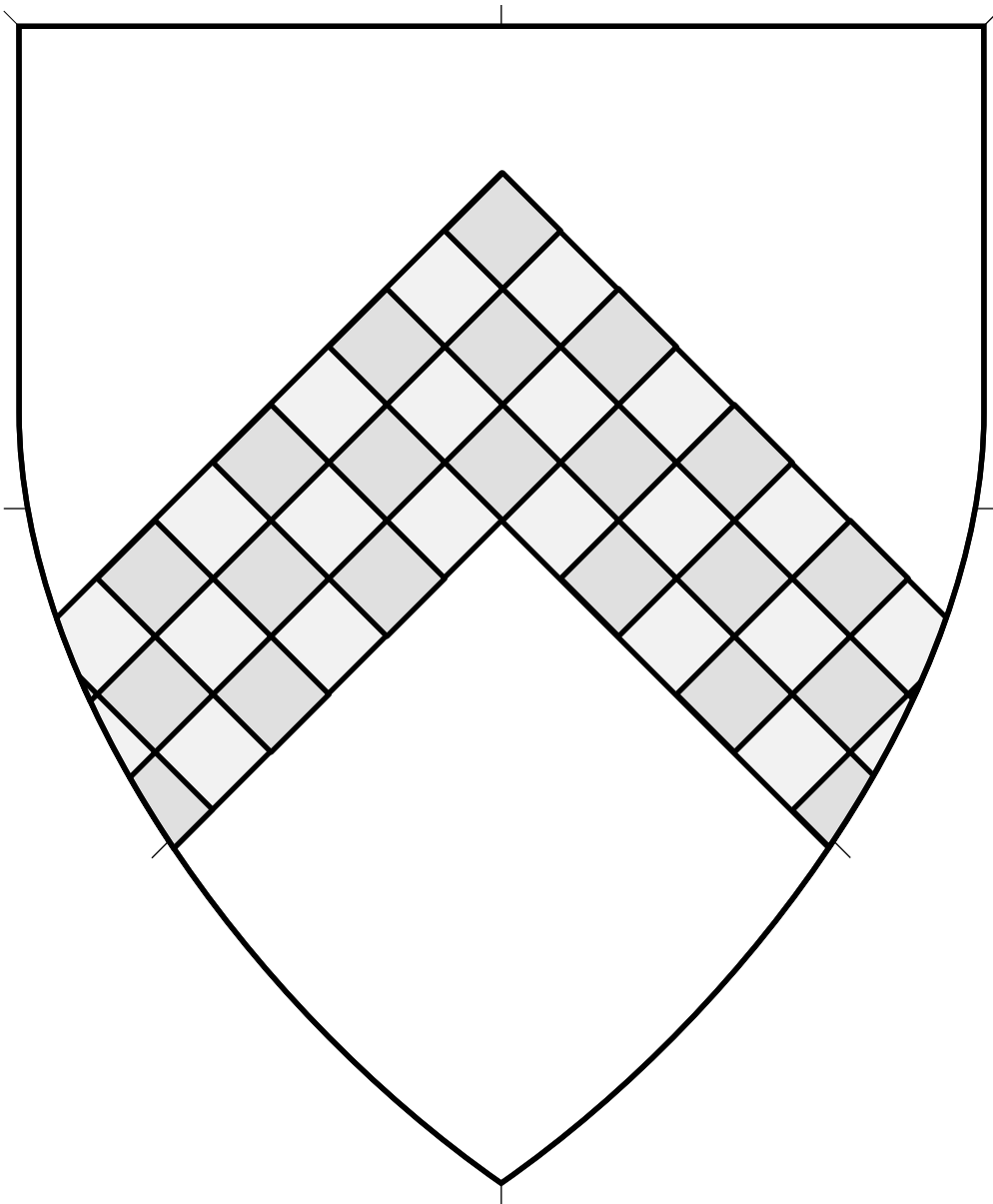

Central ordinary. This ordinary is separated into alternating squares of contrasting tinctures.

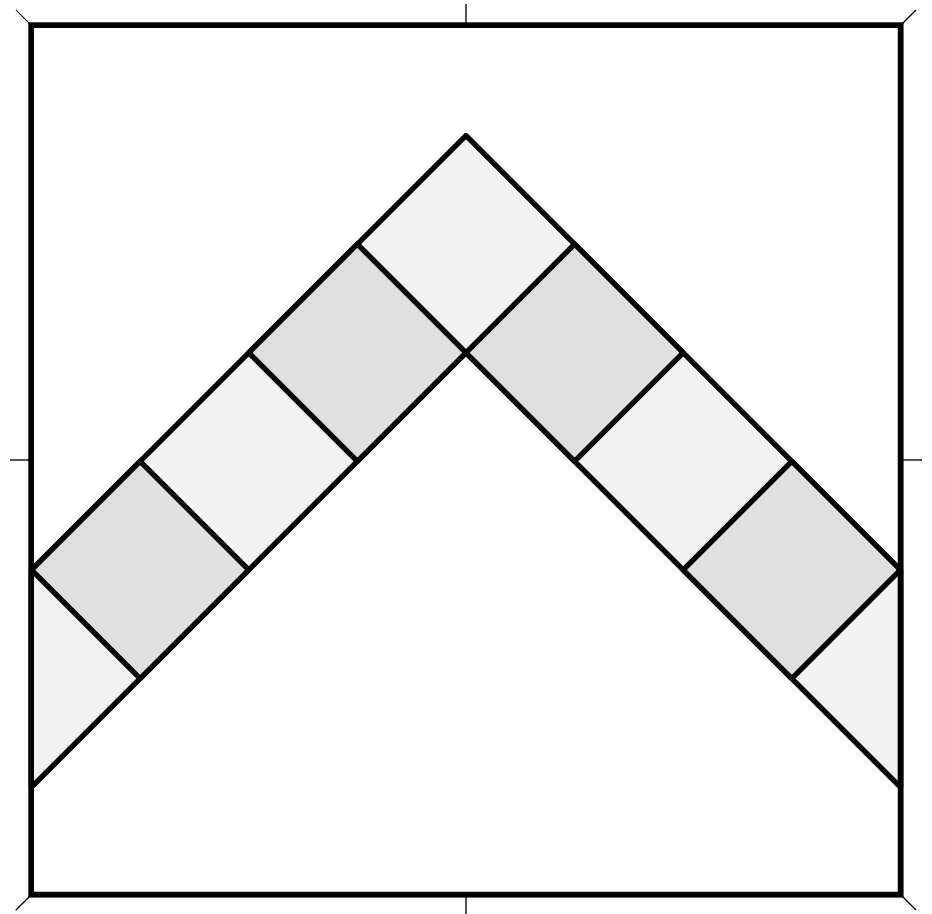
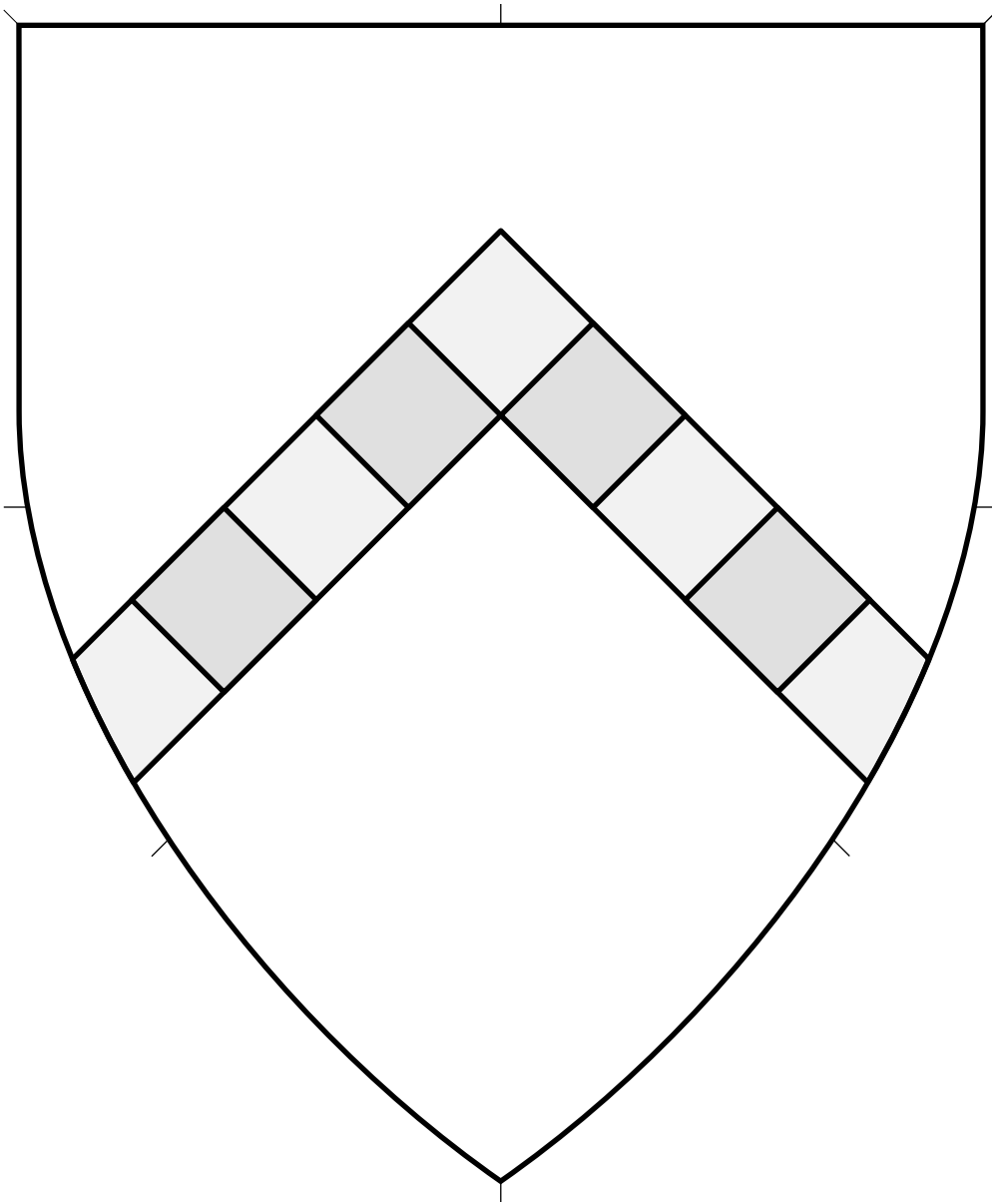

Central ordinary. This ordinary is separated into alternating squares of contrasting tinctures.

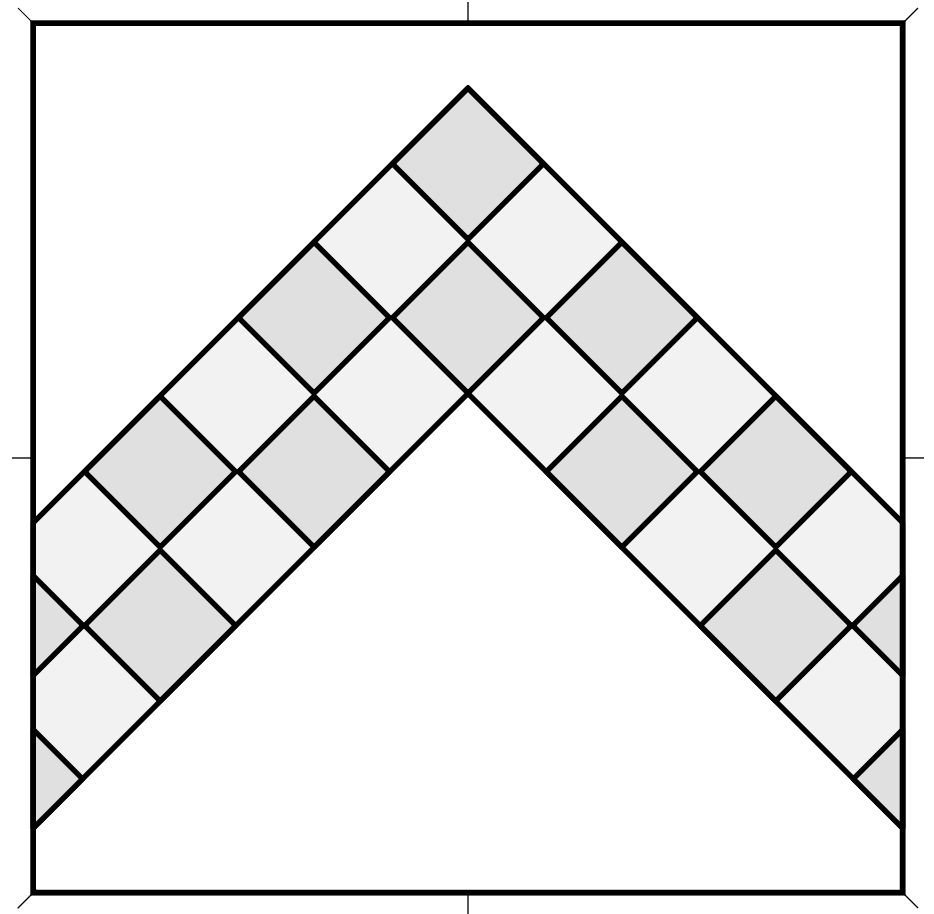
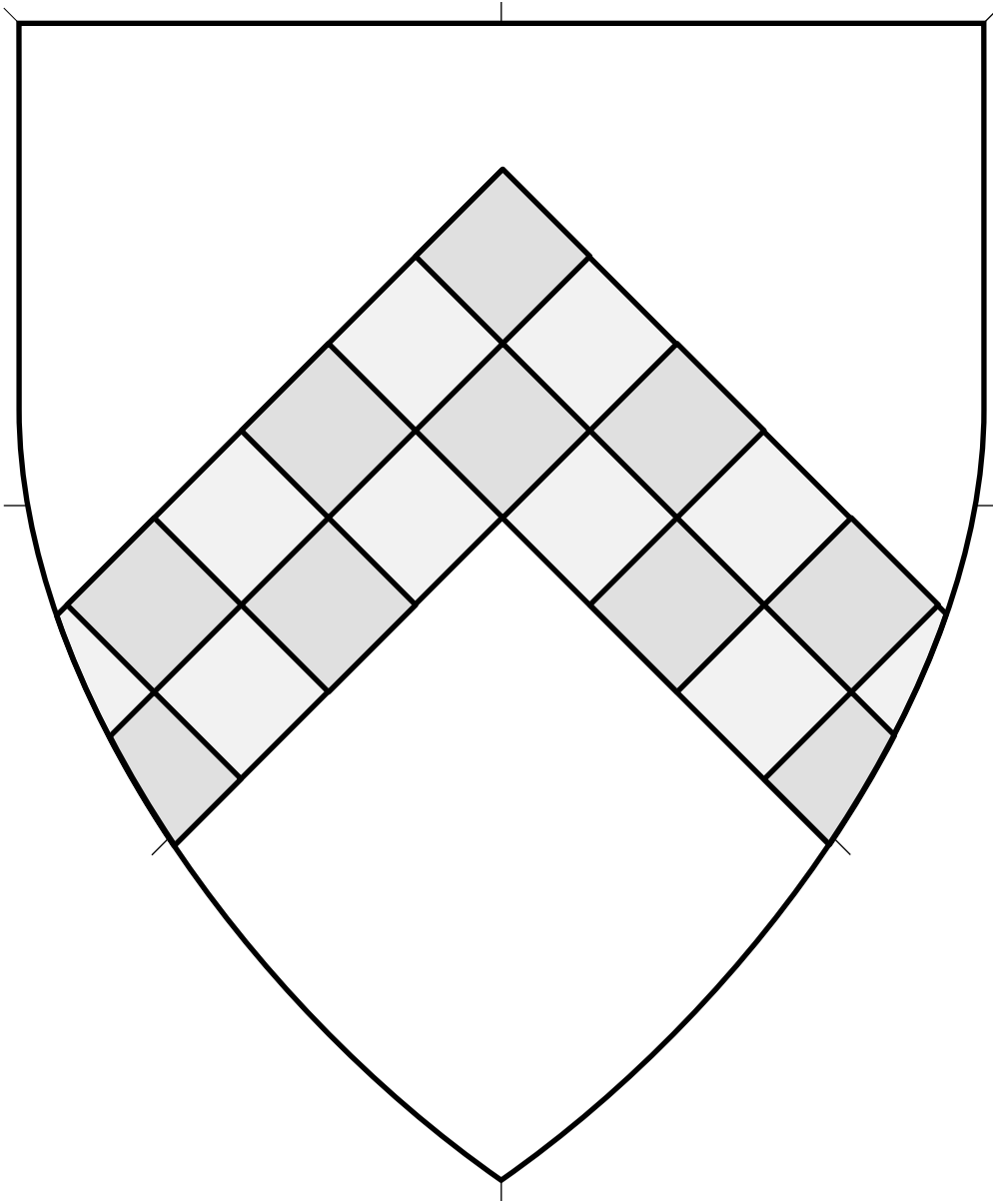

Central ordinary. This ordinary is separated into alternating squares of contrasting tinctures.

Chevron Counter-compony (1) 4.214

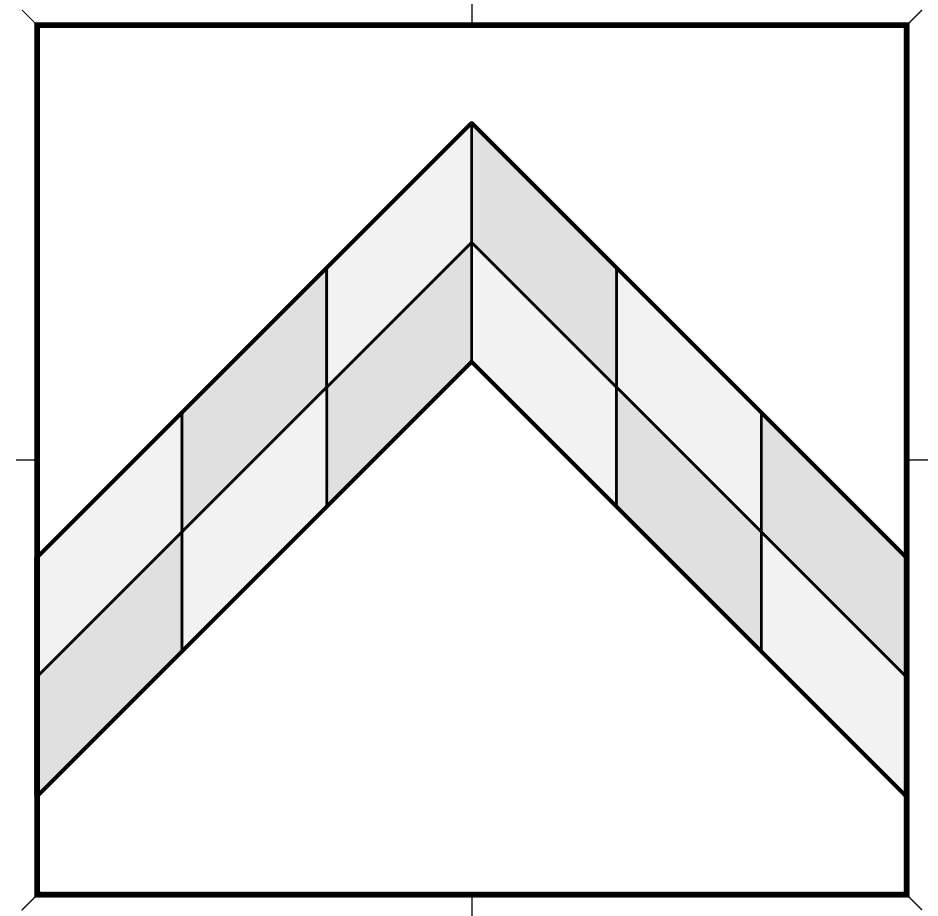
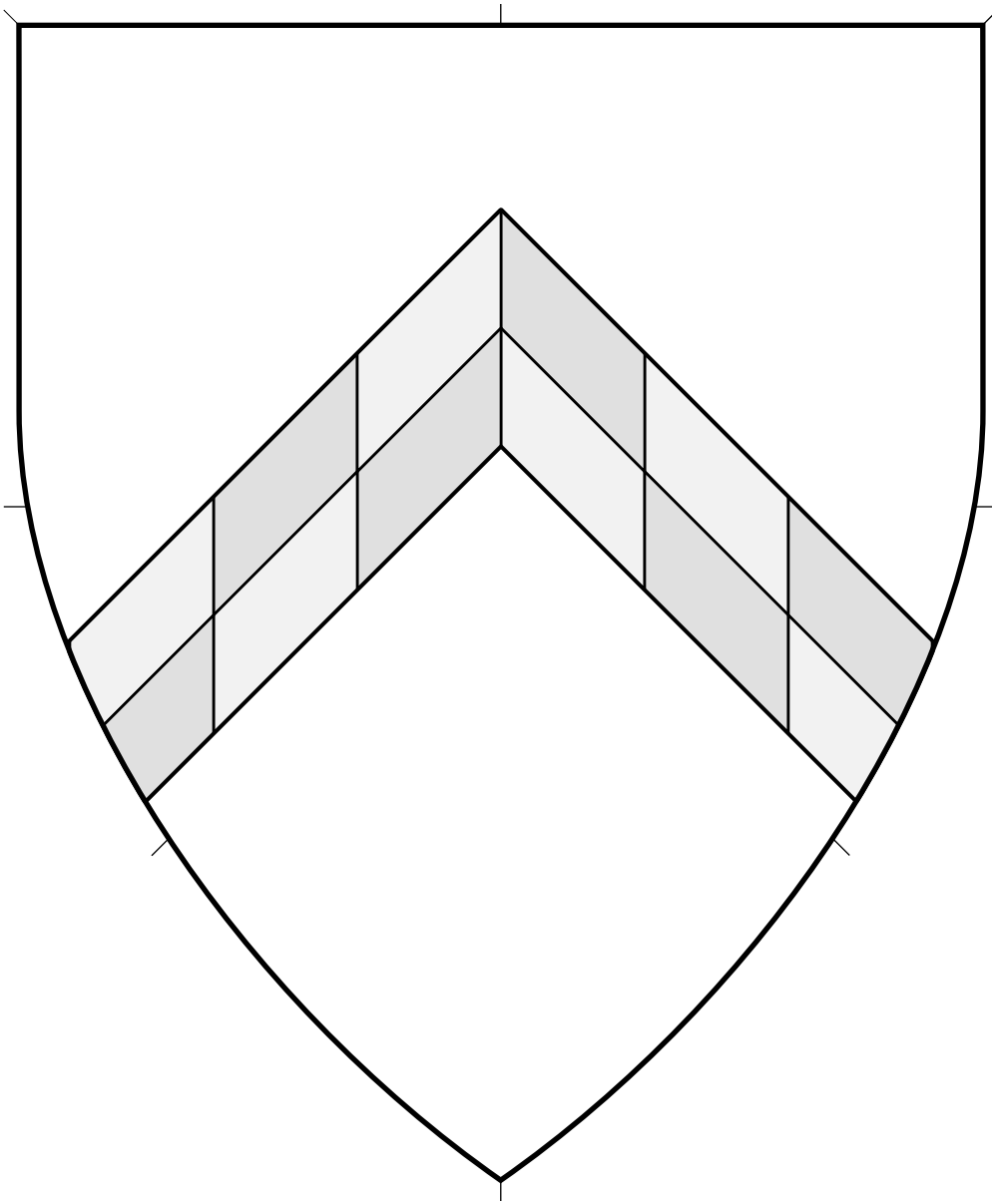

Central ordinary. This ordinary is separated into alternating squares of contrasting tinctures.

Chevron Counter-compony (2) • 4.215

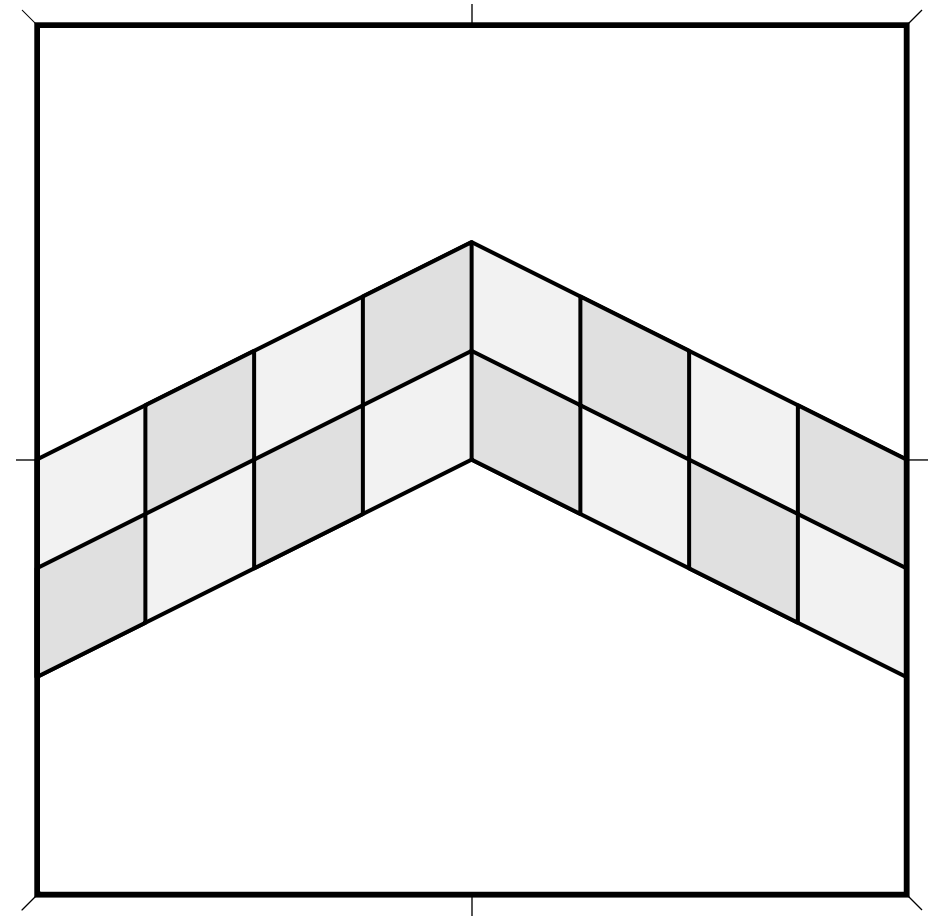
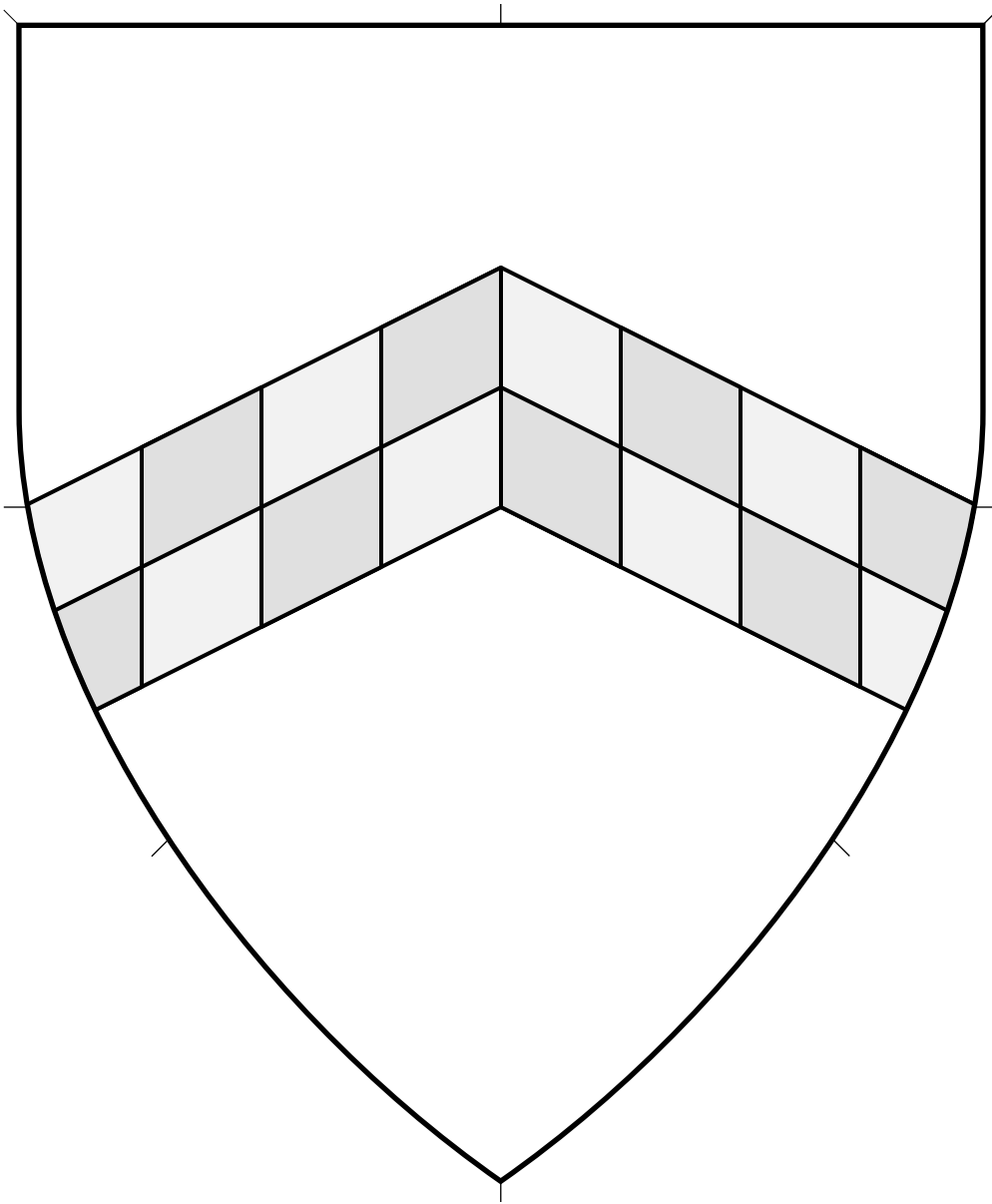

Central ordinary.

This ordinary is separated into alternating squares of contrasting tinctures.

Source: Insignia Anglica.
Artist unknown. (Folio 44r.)

Chevron Counter-compony (3) 4.216

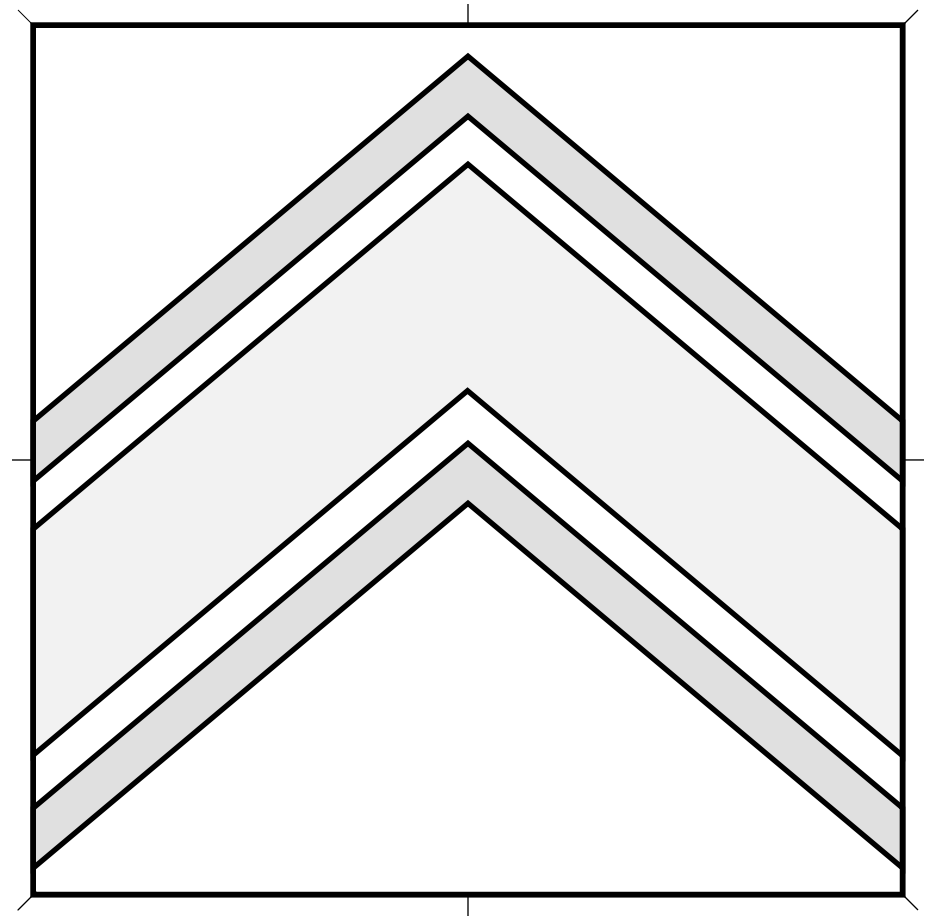
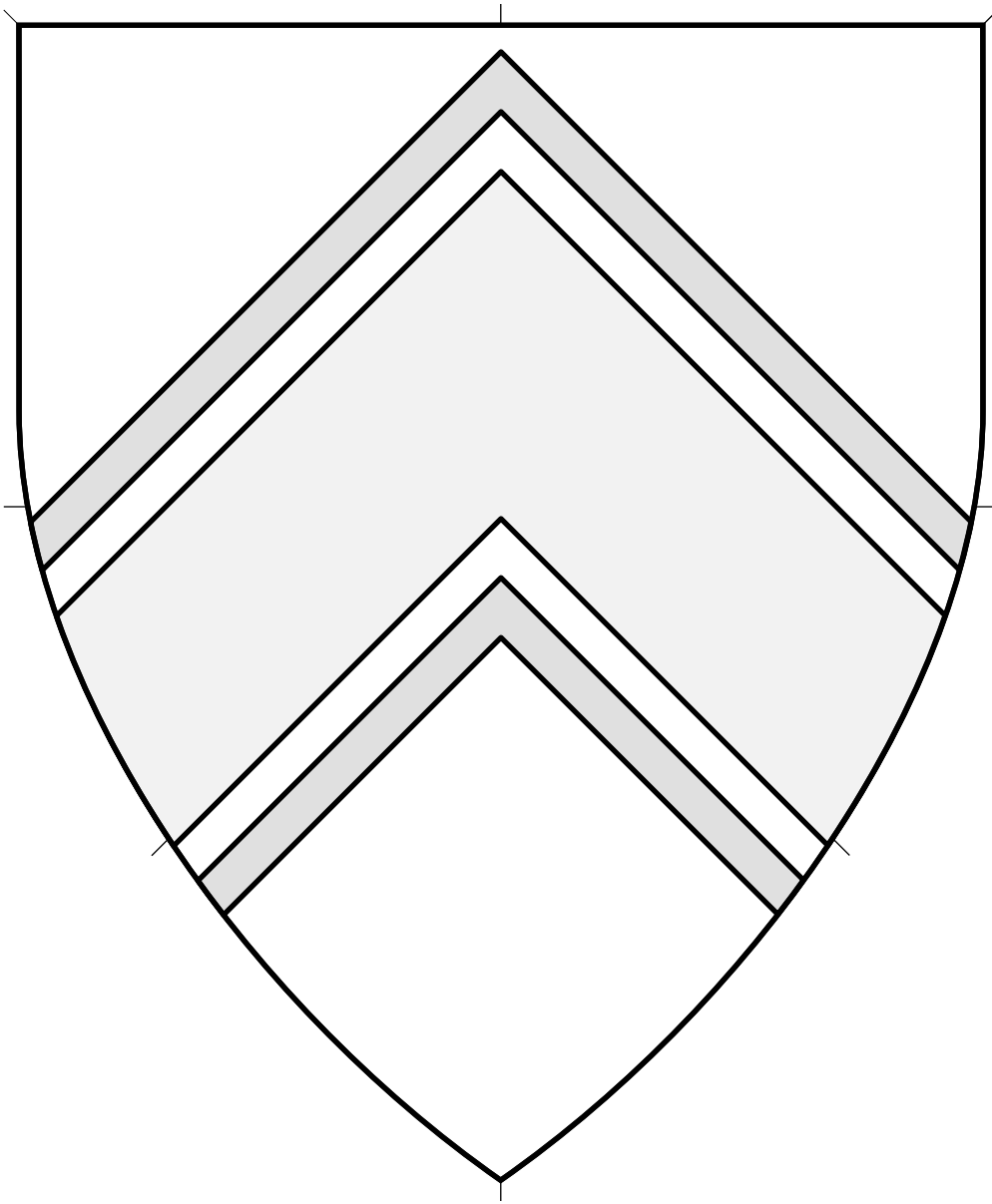

Central ordinary cotised. Also blazoned a “chevron between couple-closes.”

Chevron Cotised (1) 4.217

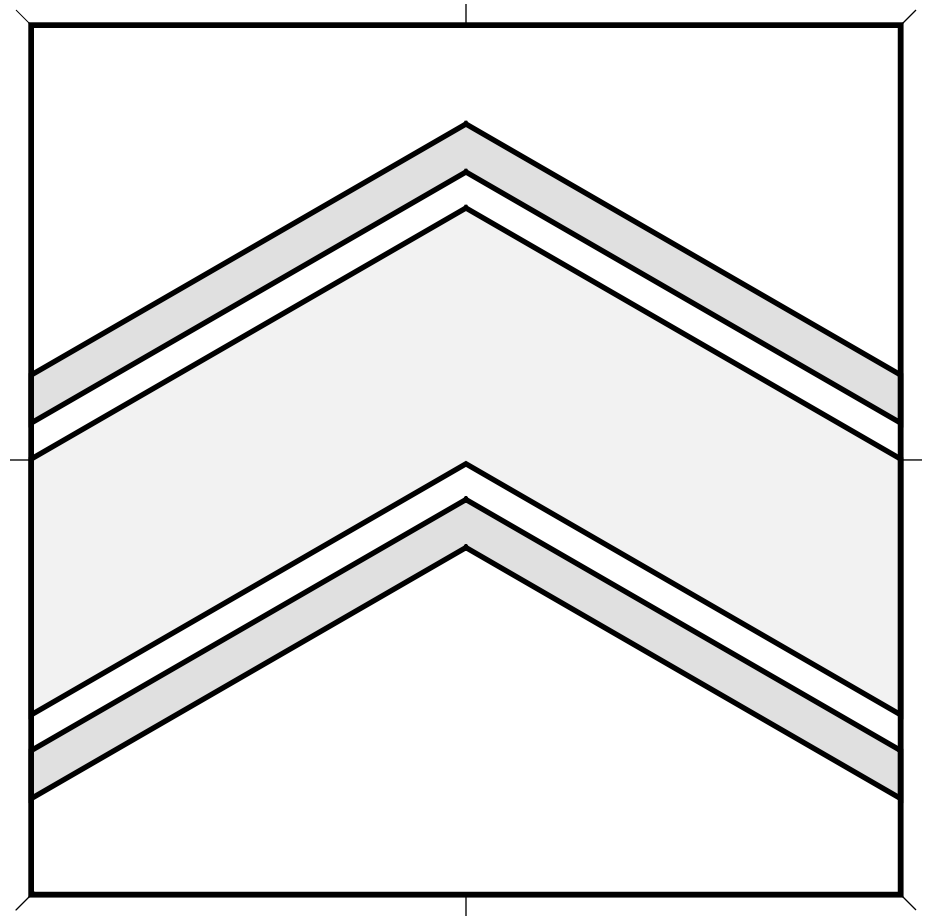
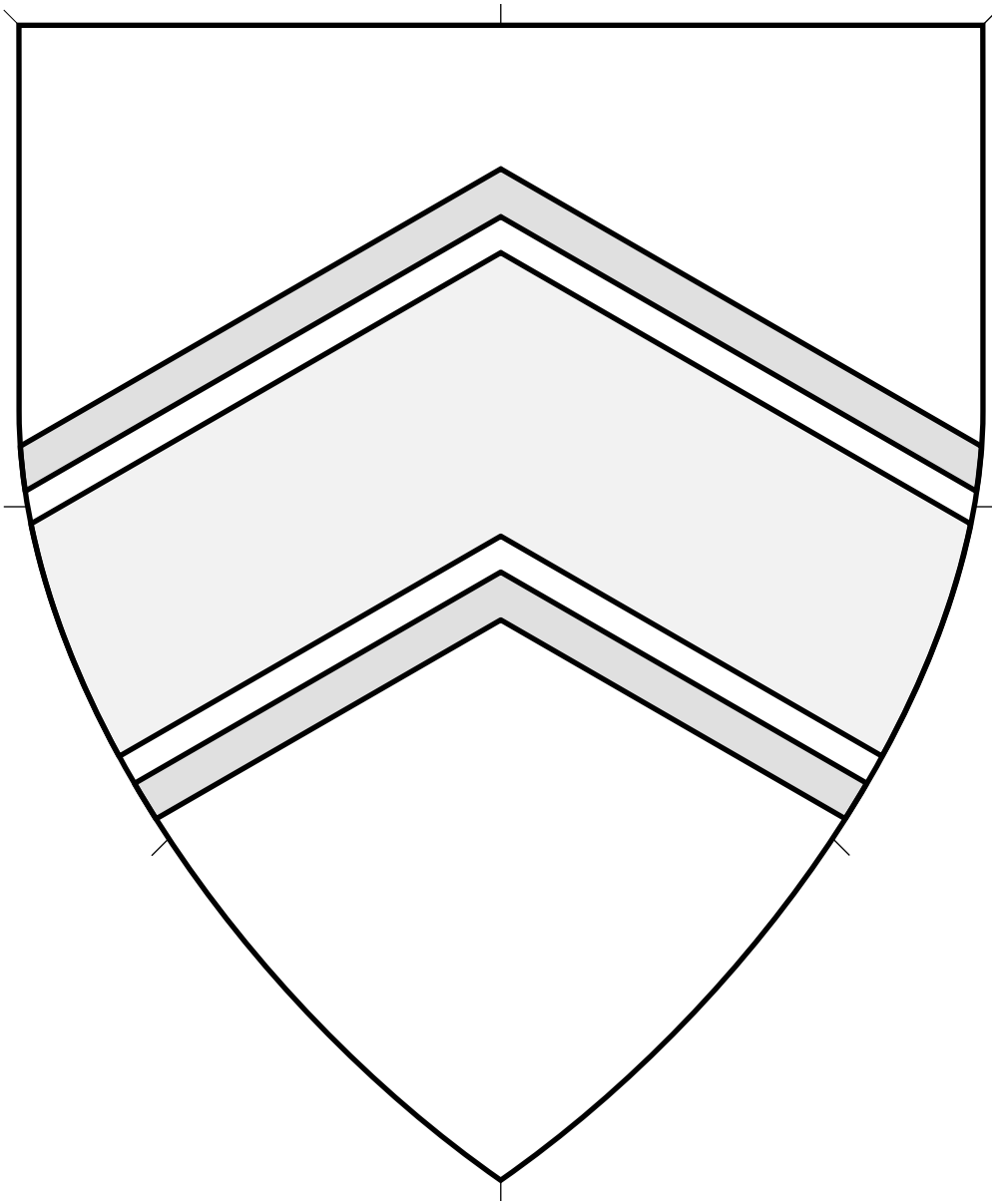

Central ordinary cotised. Also blazoned a “chevron between couple-closes.”

Chevron Cotised (2) 4.218

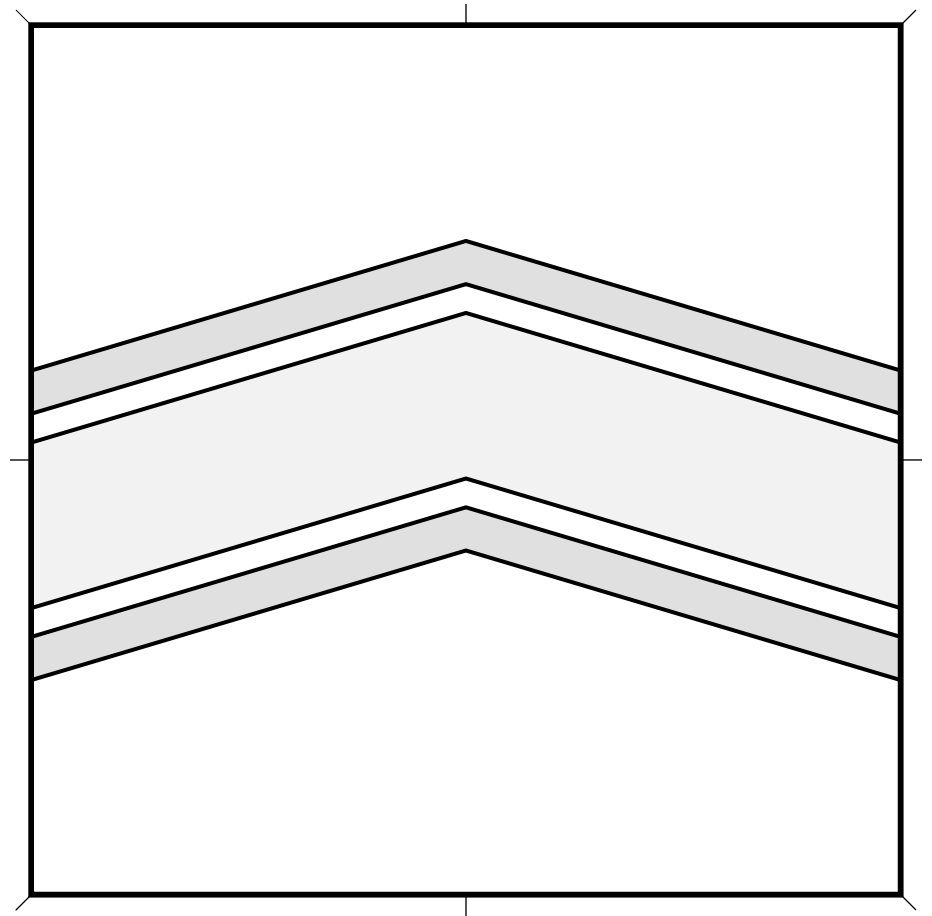
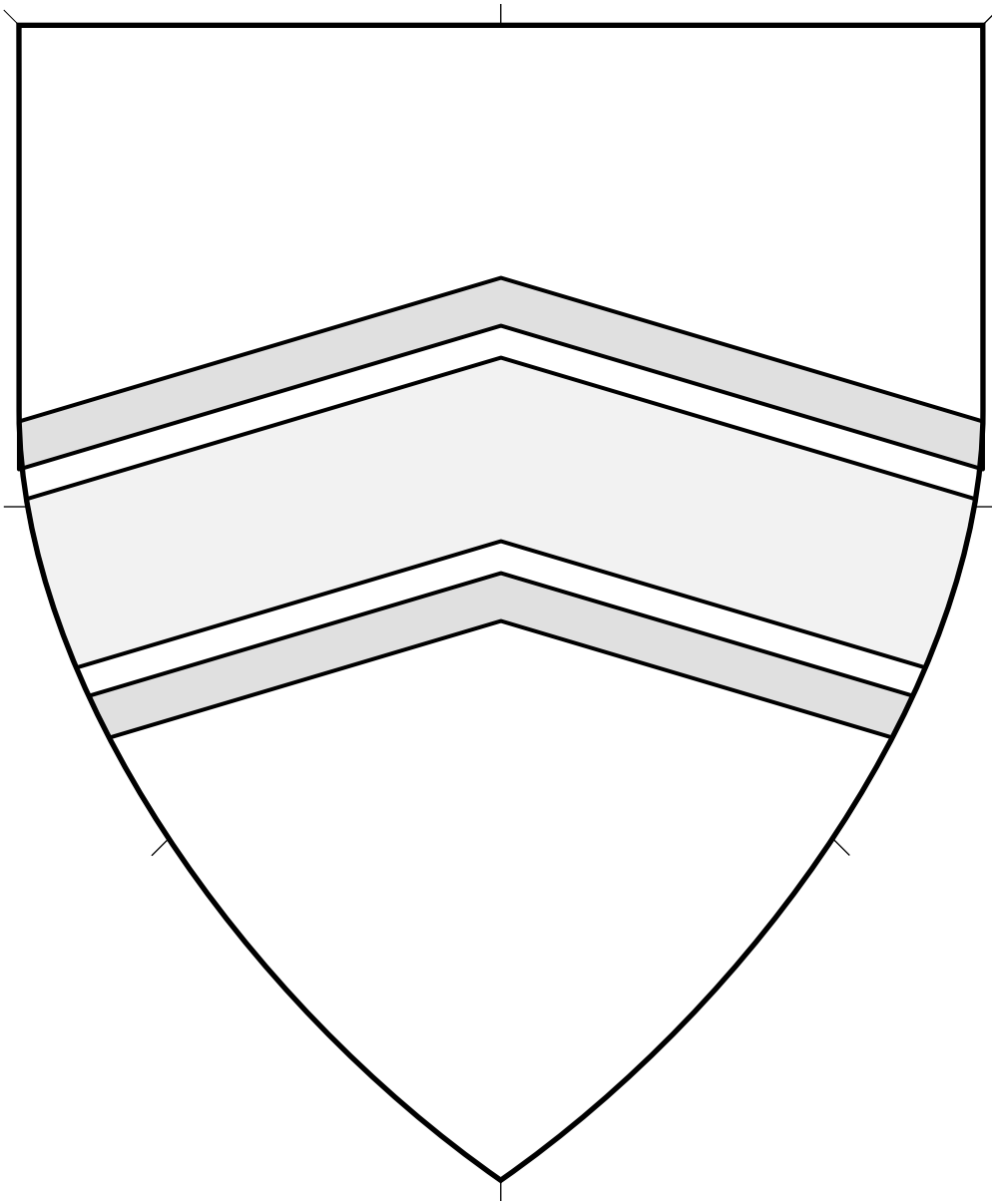

Central ordinary cotised. Also blazoned a “chevron between couple-closes.”

Chevron Cotised (3) 4.219

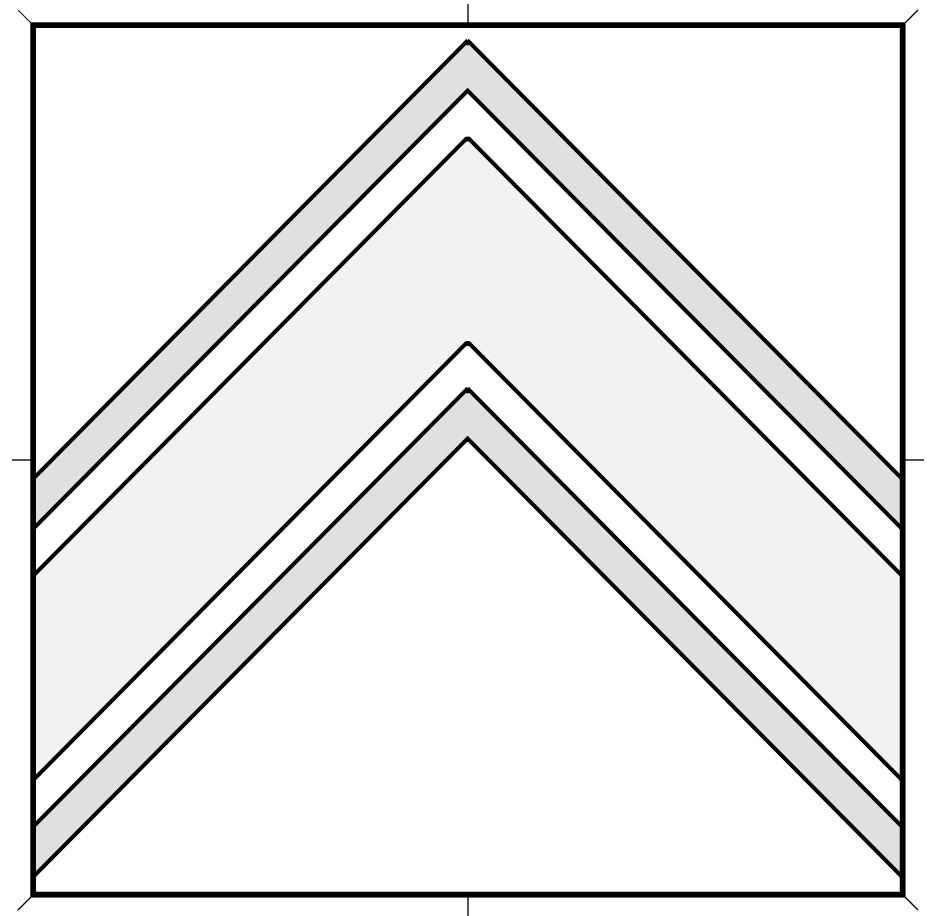
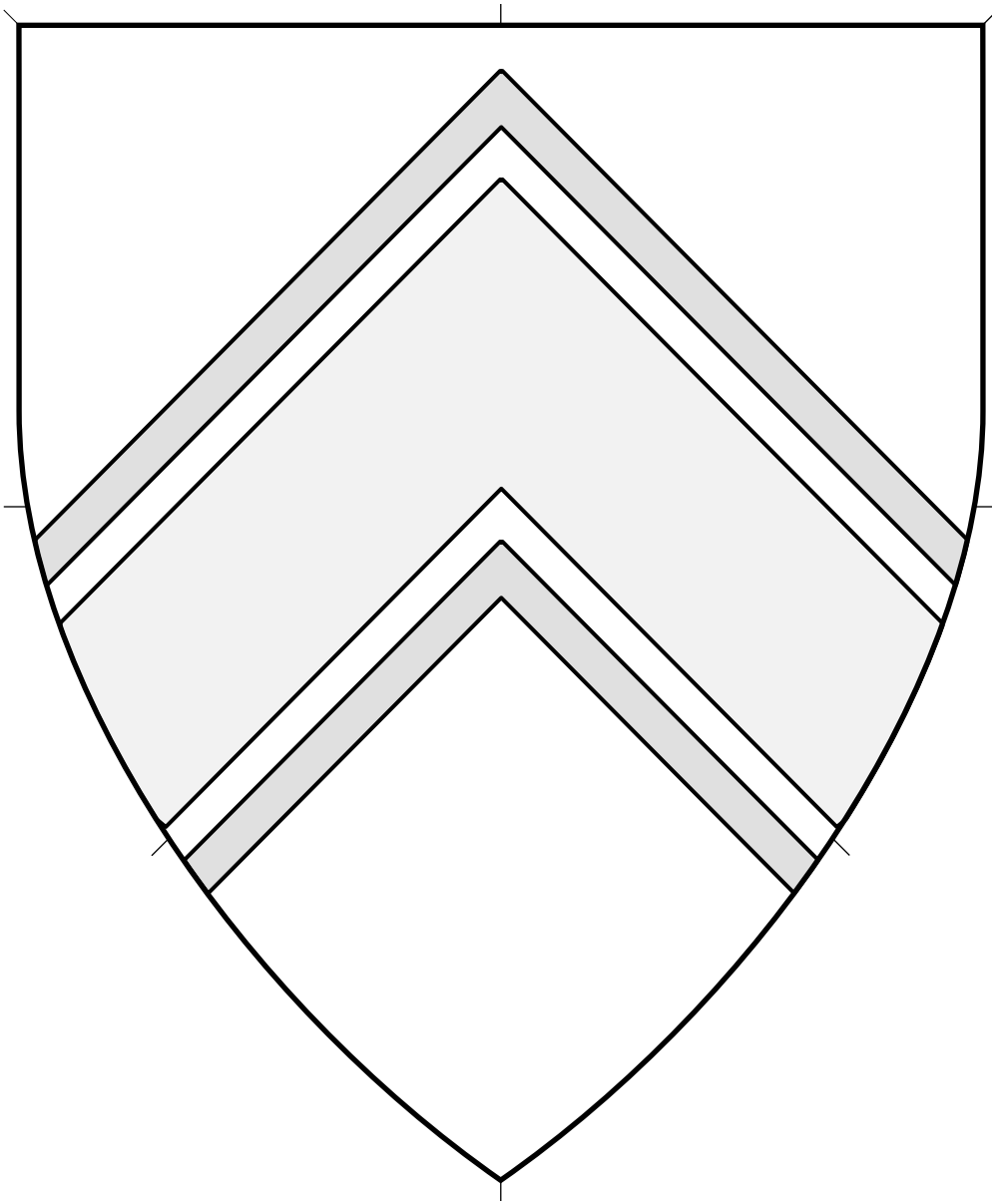

Central ordinary.

Source: Viking Answer Lady SVG Images For Heraldry. Artist: Gunnvôr silfrhárr. Adapted by Mathghamhain Ua Ruadháin.

Chevron Cotised (4) 4.220

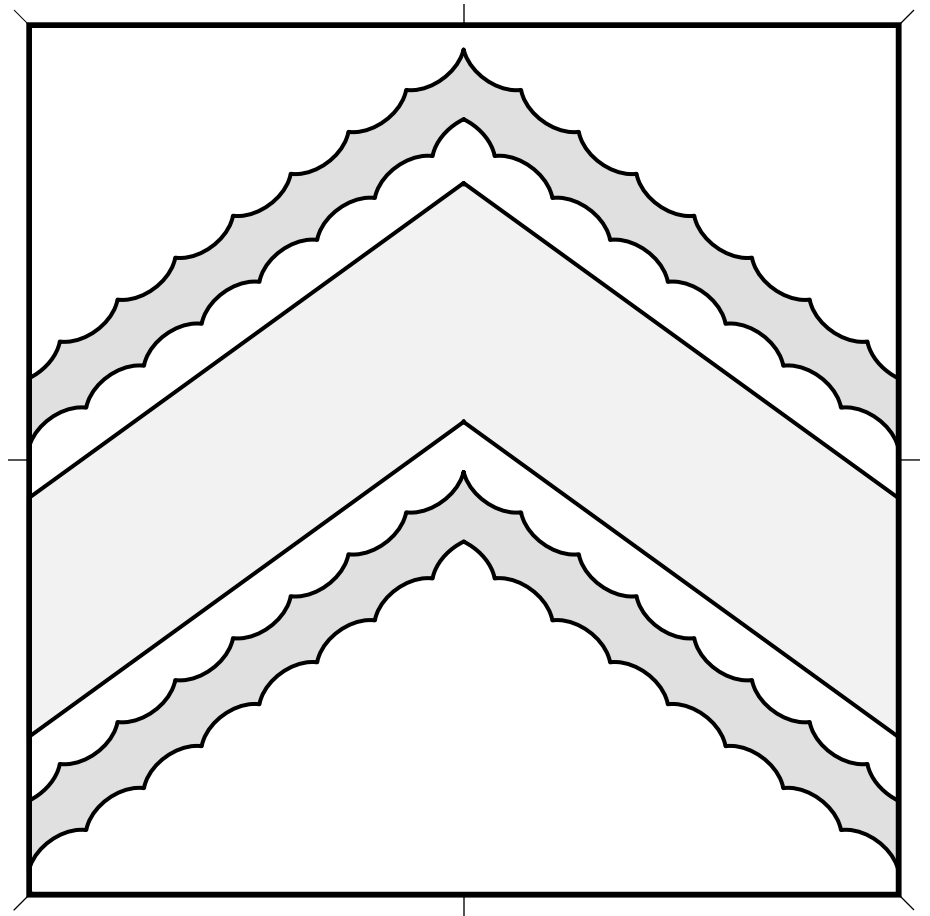
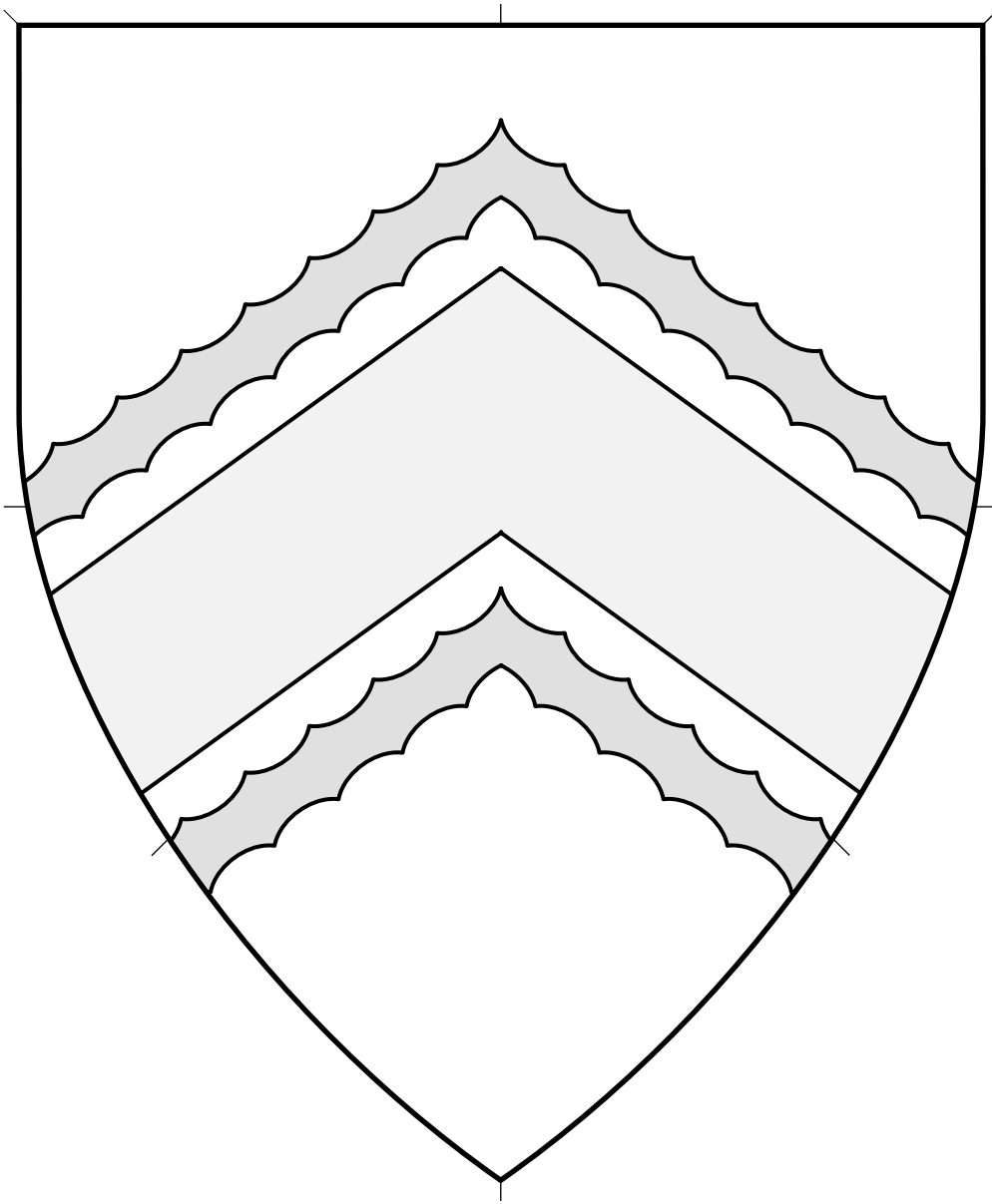

Central ordinary.

Source: *Insignia Anglica*. Artist unknown.
(Folio 44v.)

Chevron Coticised Engrailed 4.221

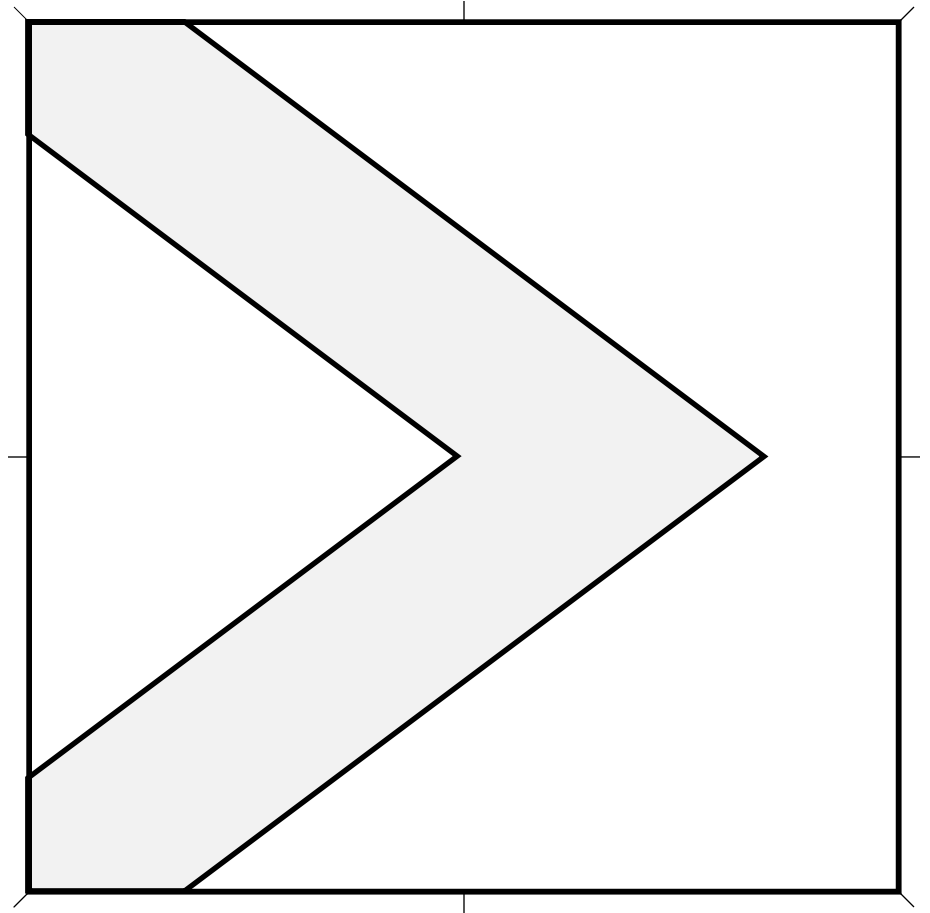
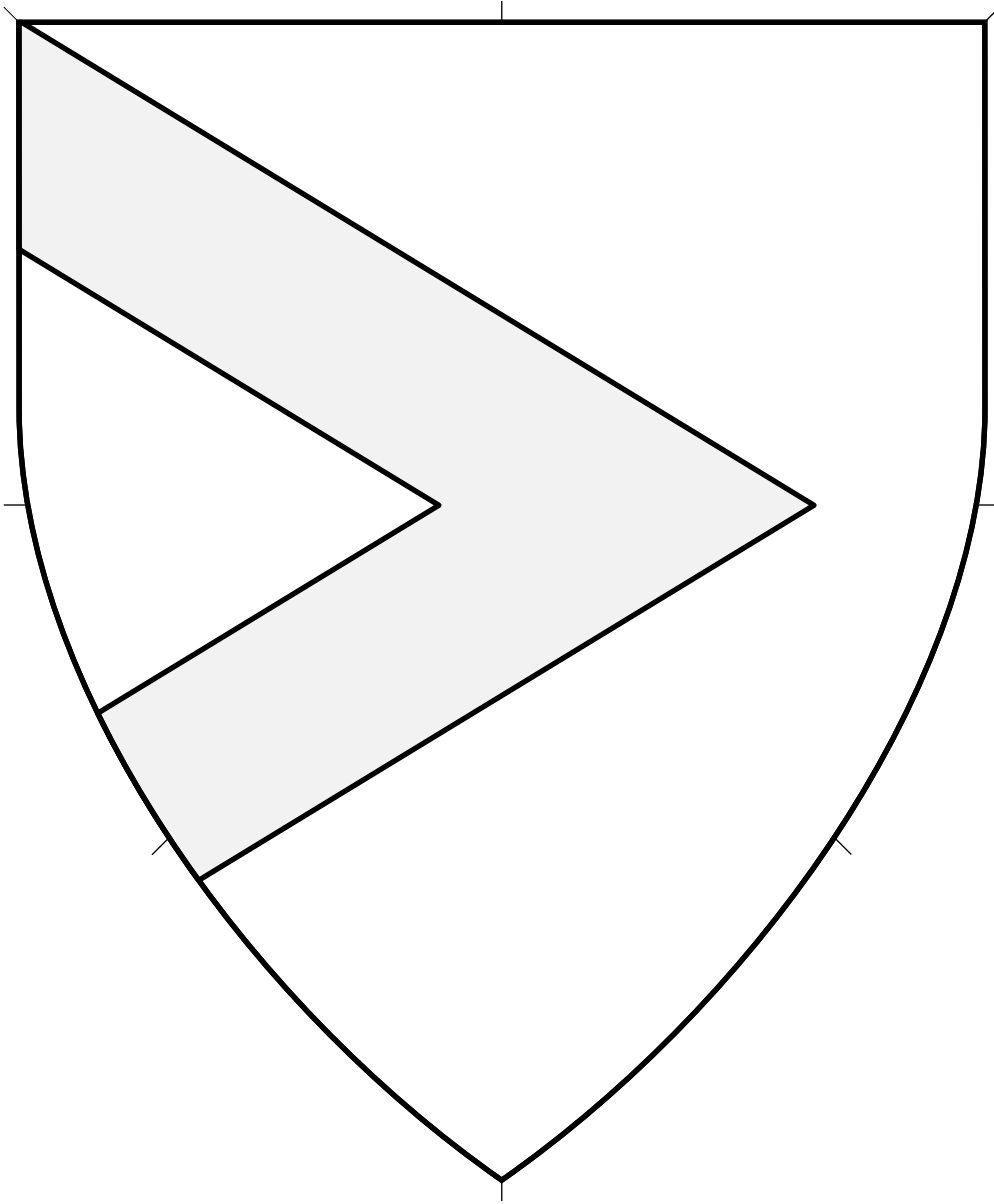

Central ordinary.

Chevron Couched From Dexter 4.222

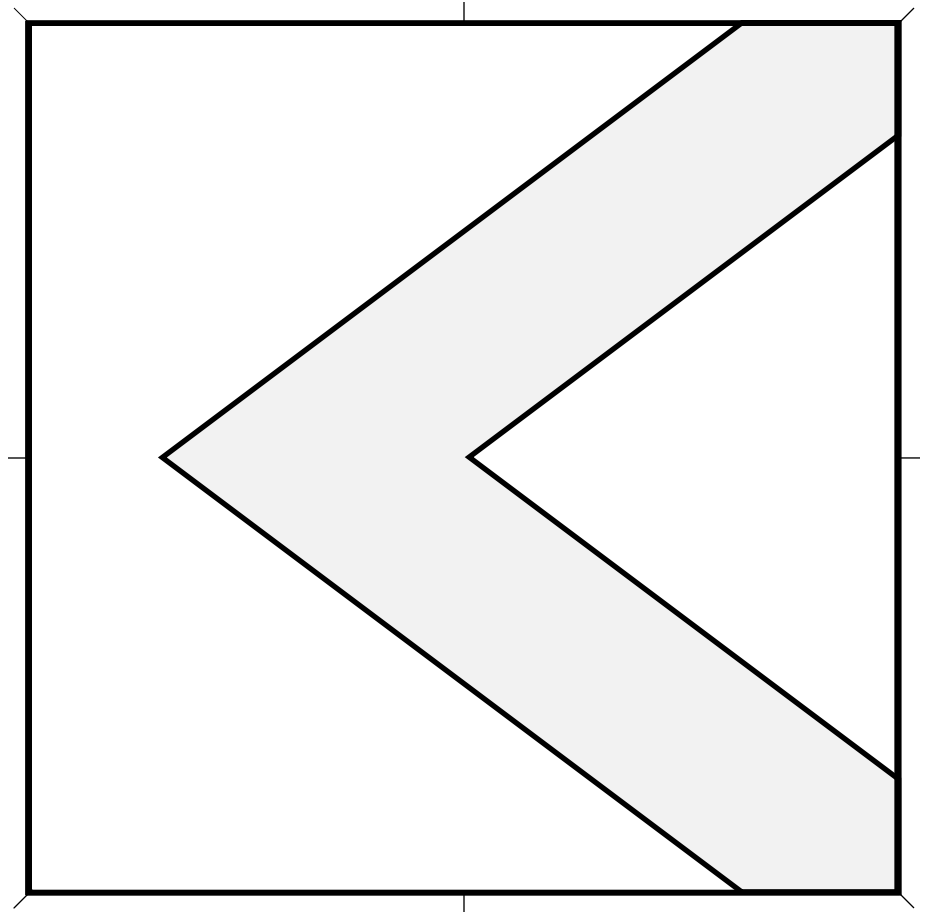
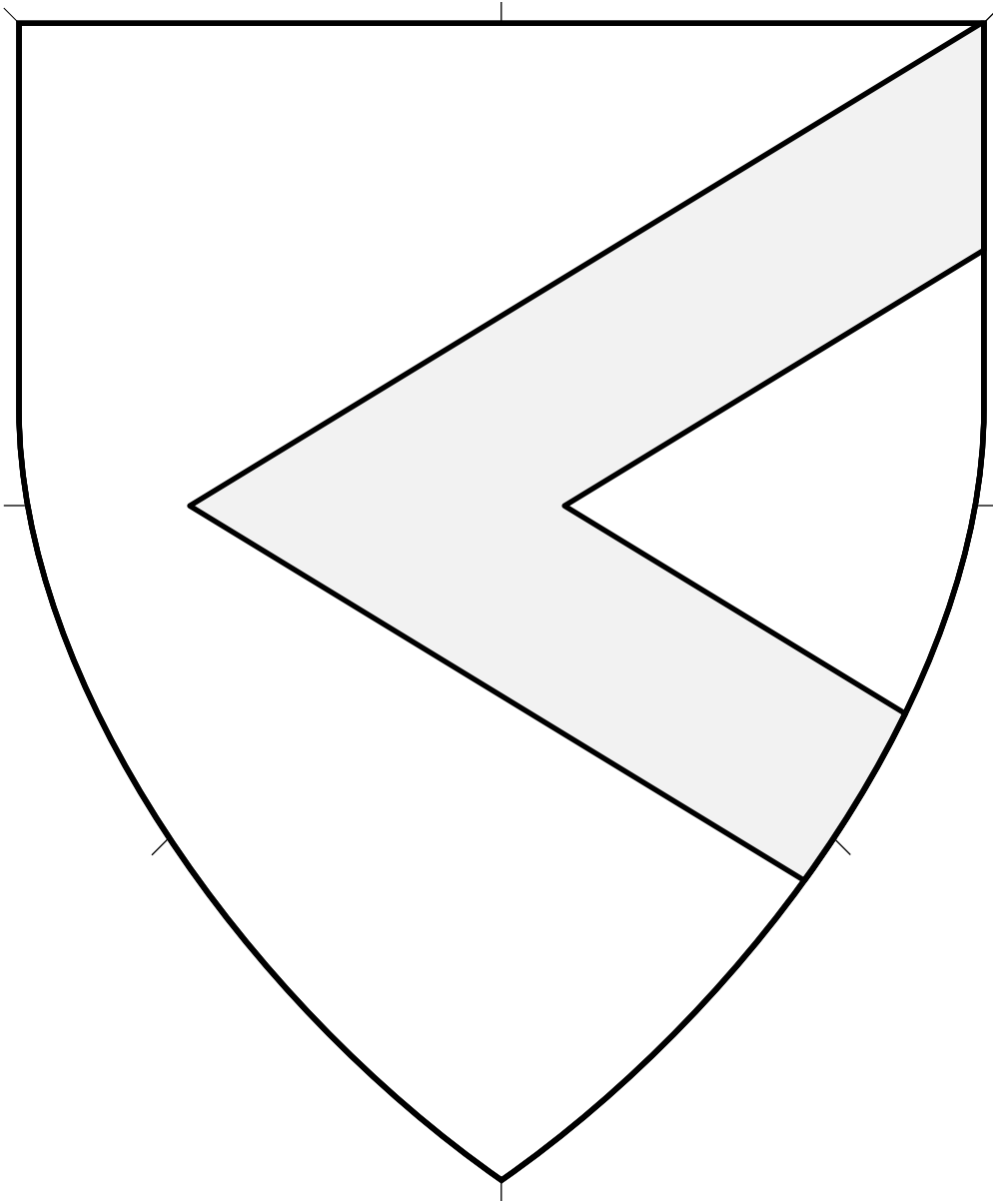

Central ordinary.

Chevron Couched From Sinister 4.223

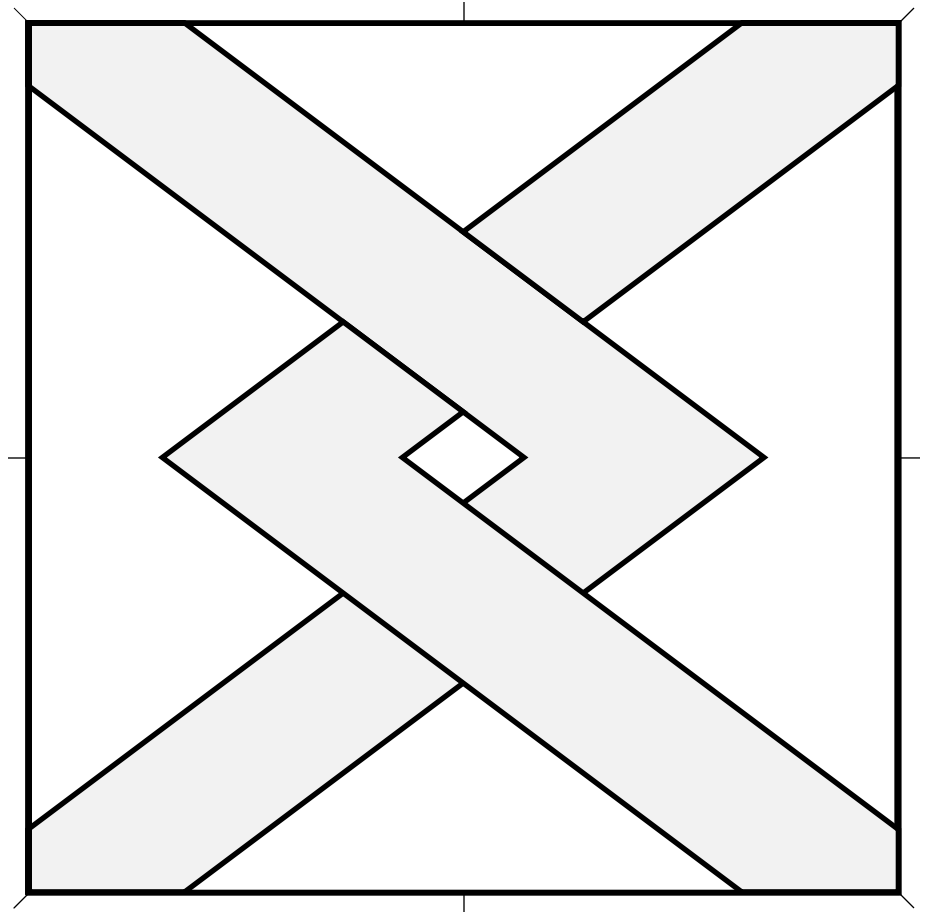
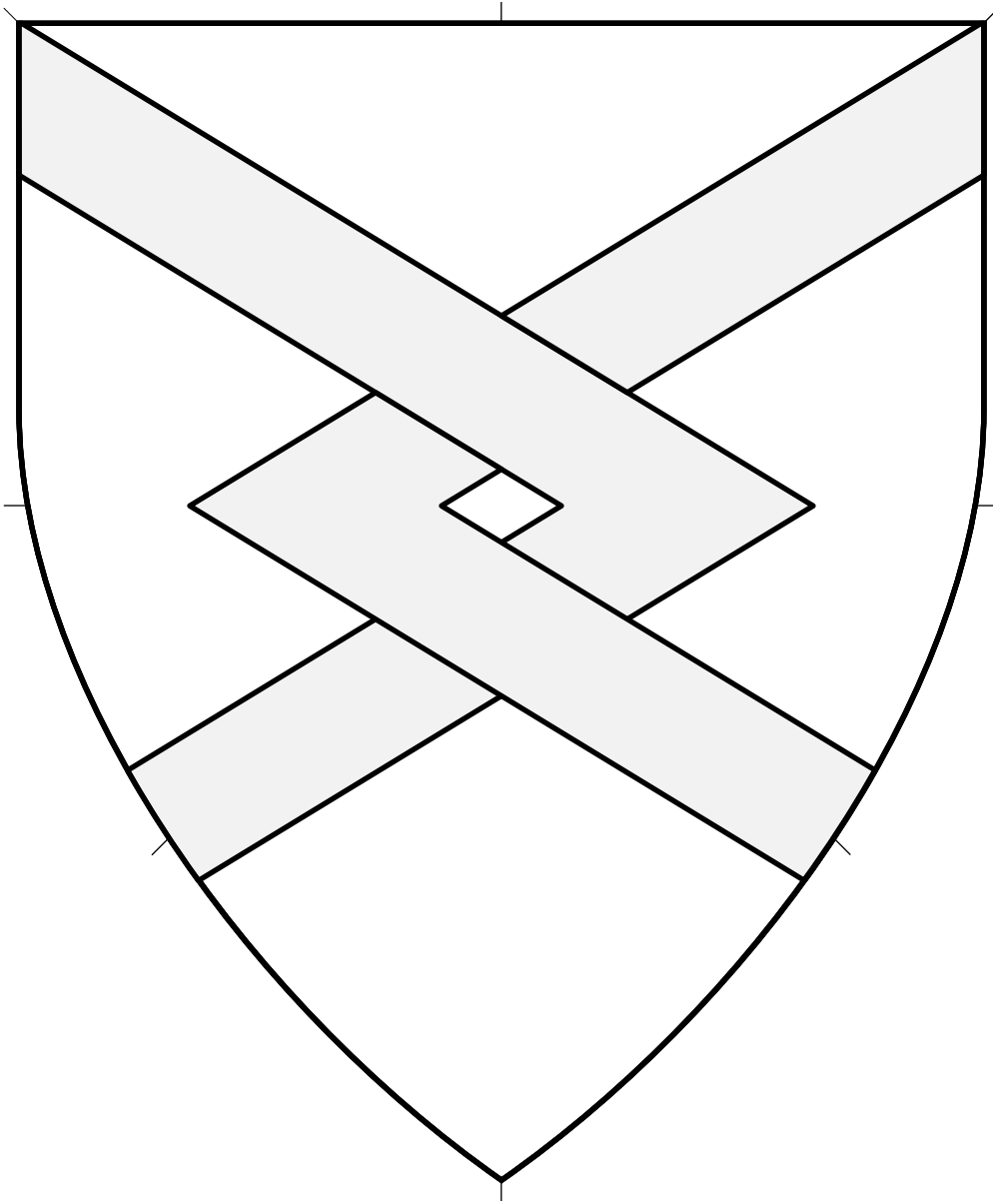

Central ordinary.

Chevrons, Two, Couched and Braced 4.224

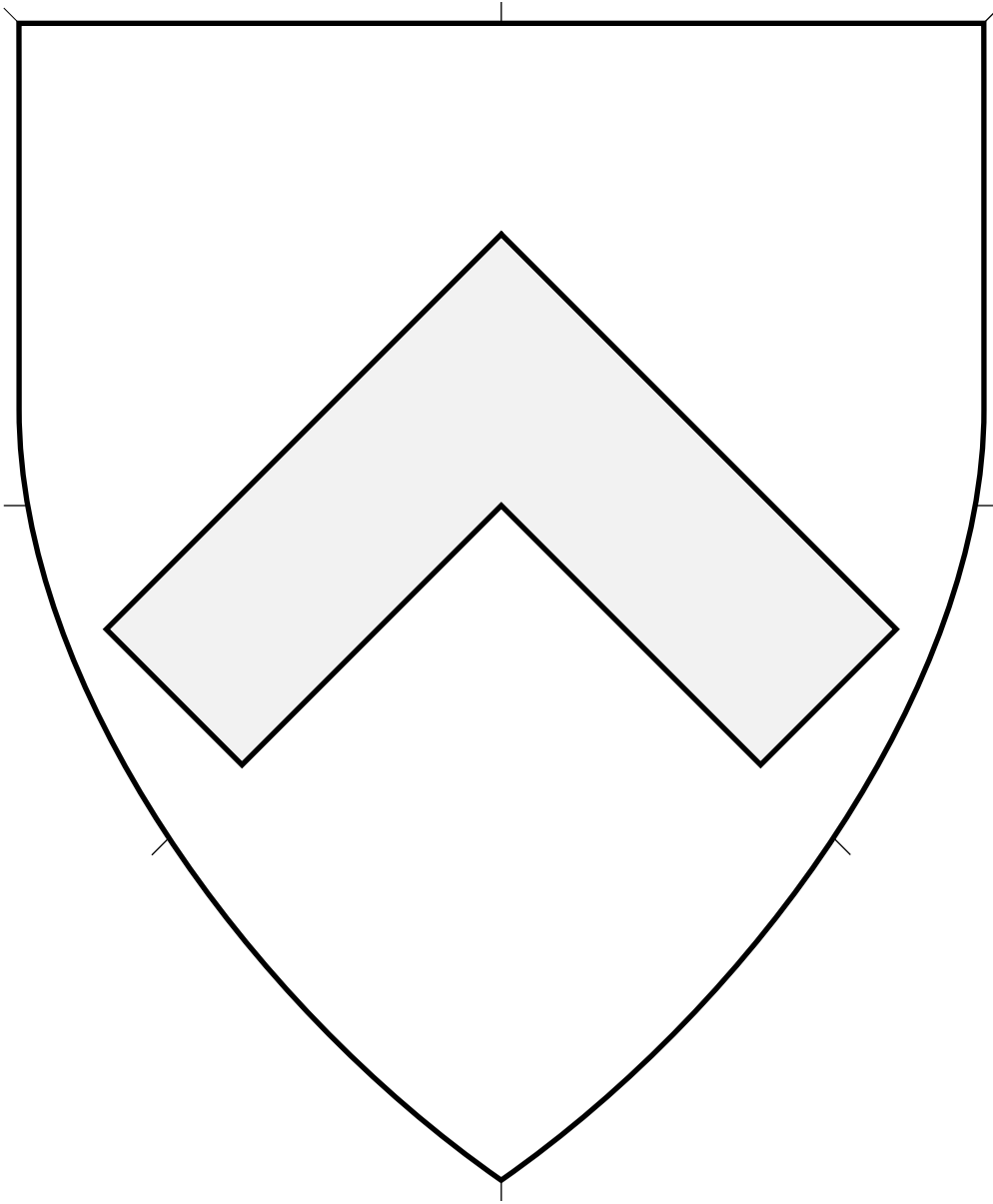

Couped ordinary.

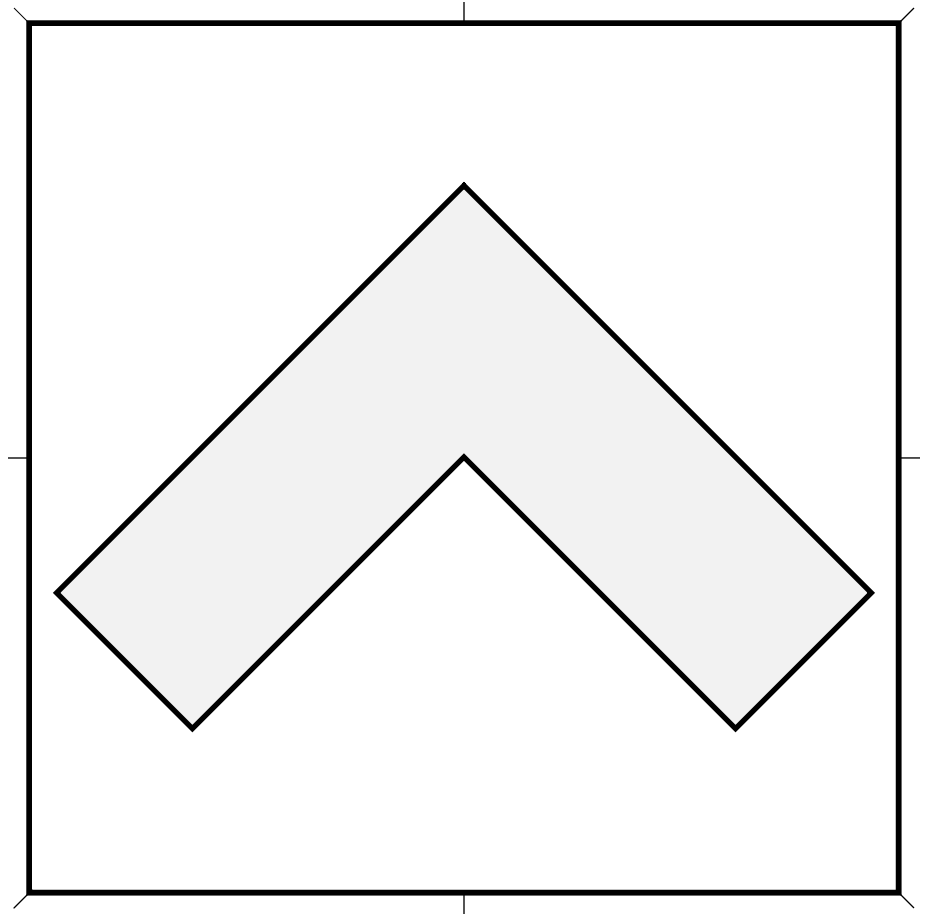

Chevron Couped (1) • 4.225

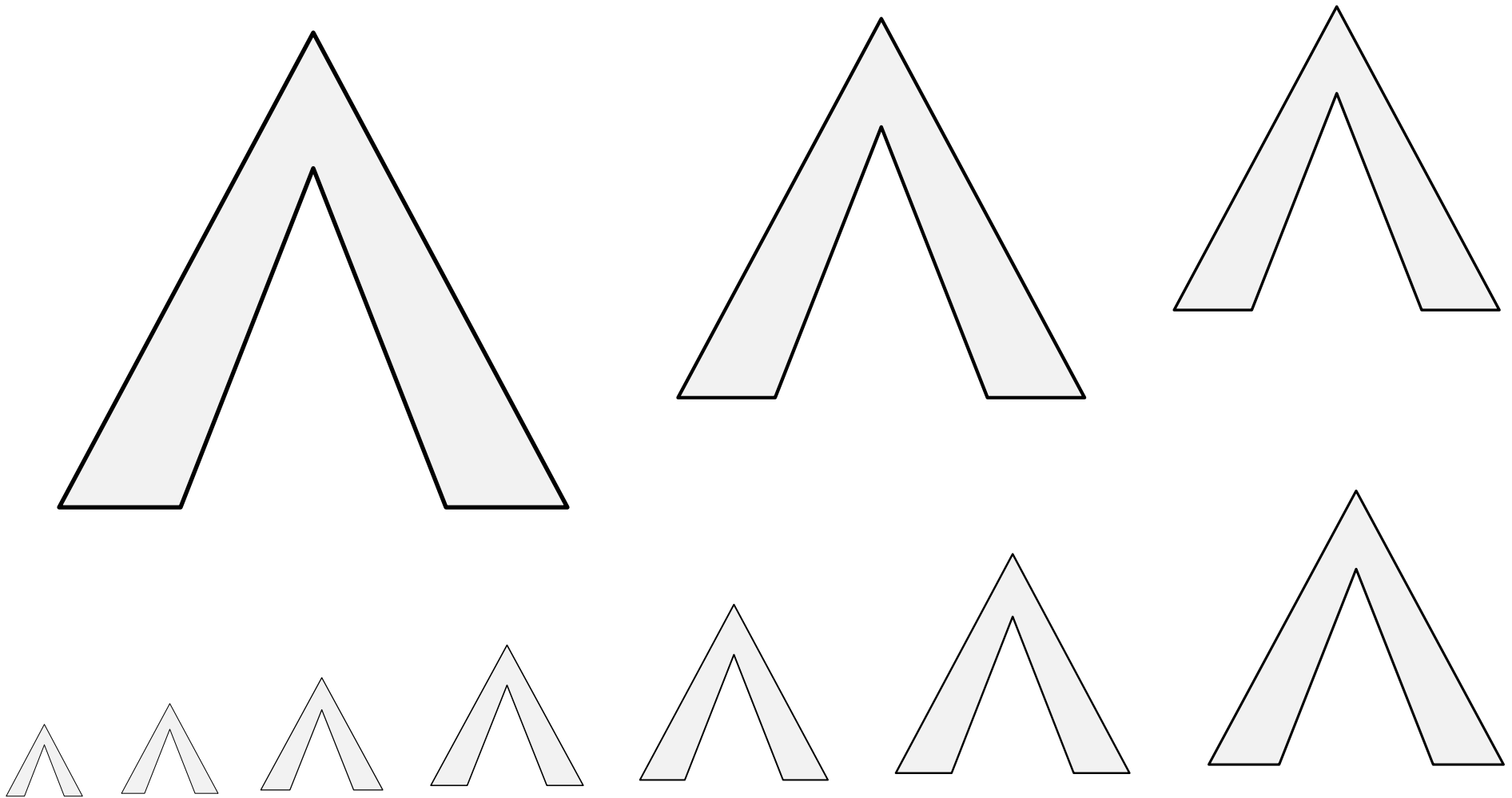

Couped ordinary.

Source: Florentine Codex. Artist unknown. (Book 12, folio 34r.)

Chevron Couped (2) • 4.226

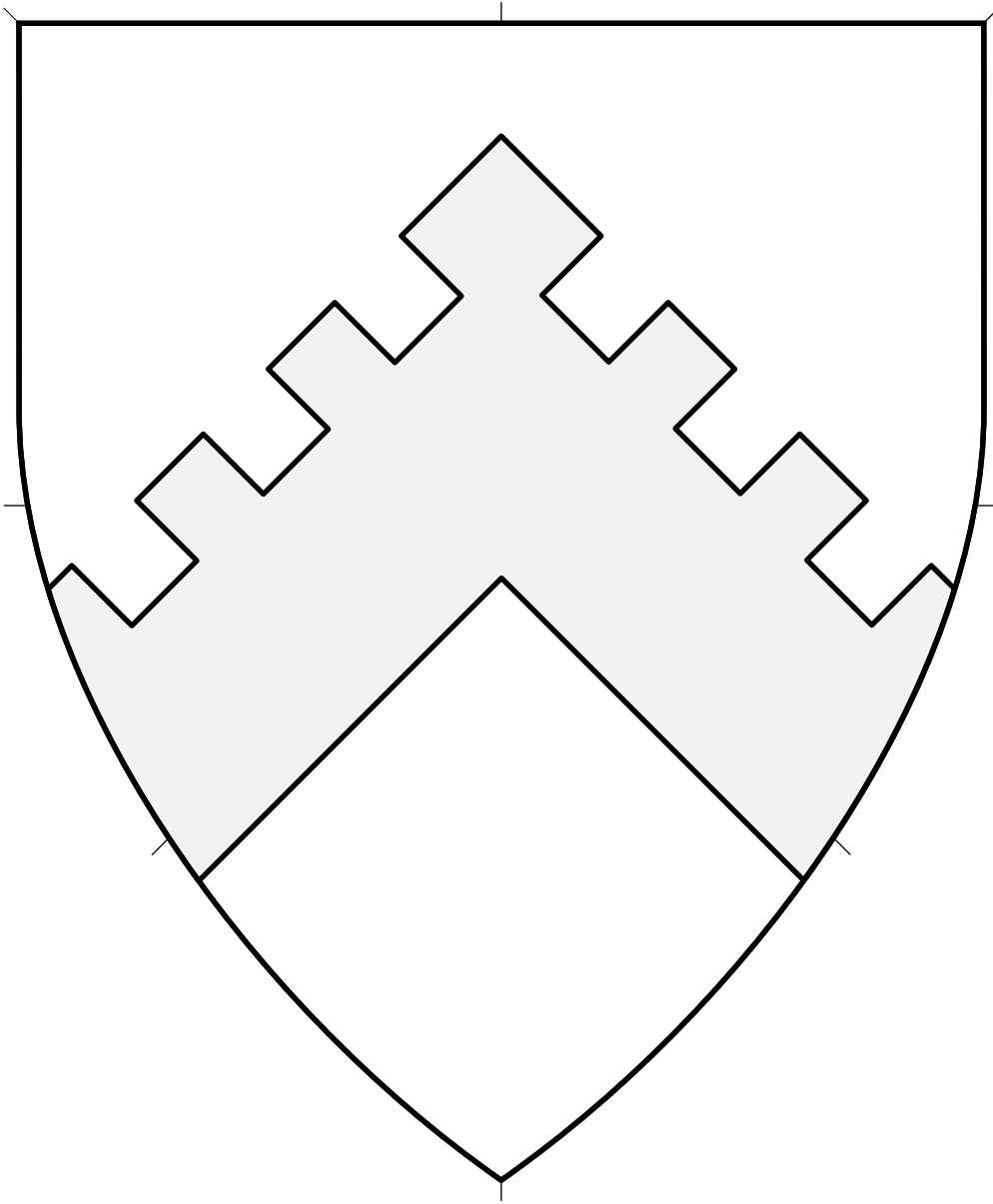

Central ordinary.

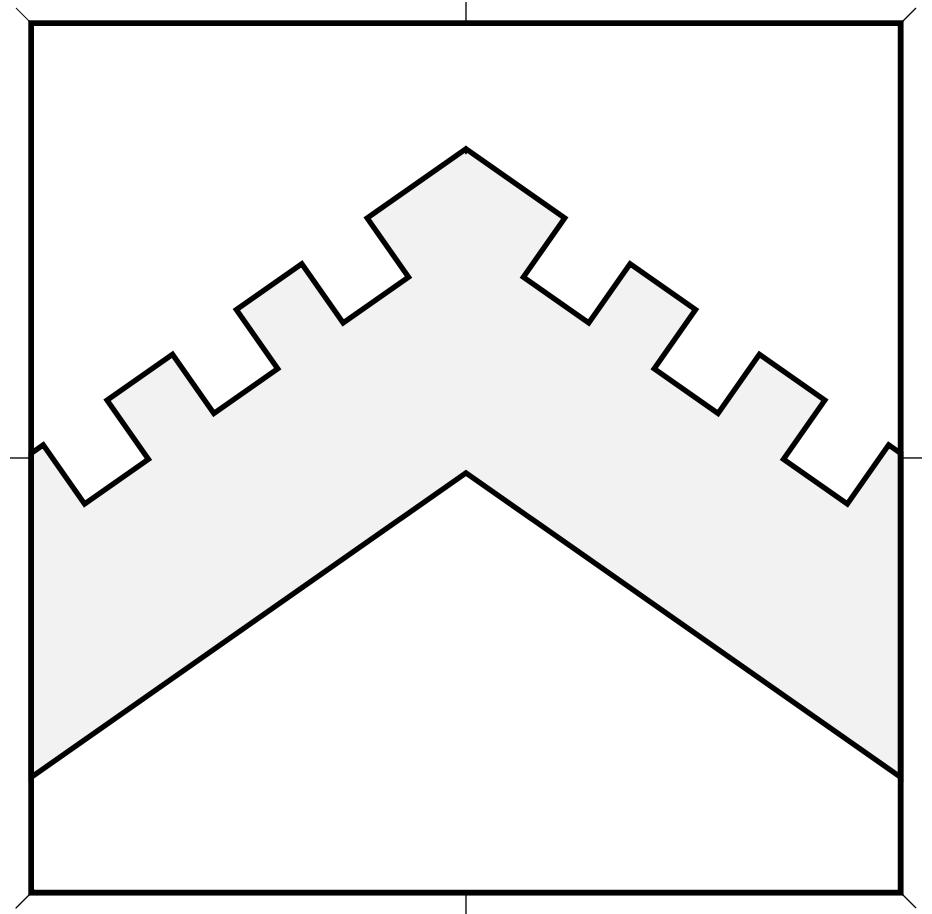

Chevron Embattled 4.227

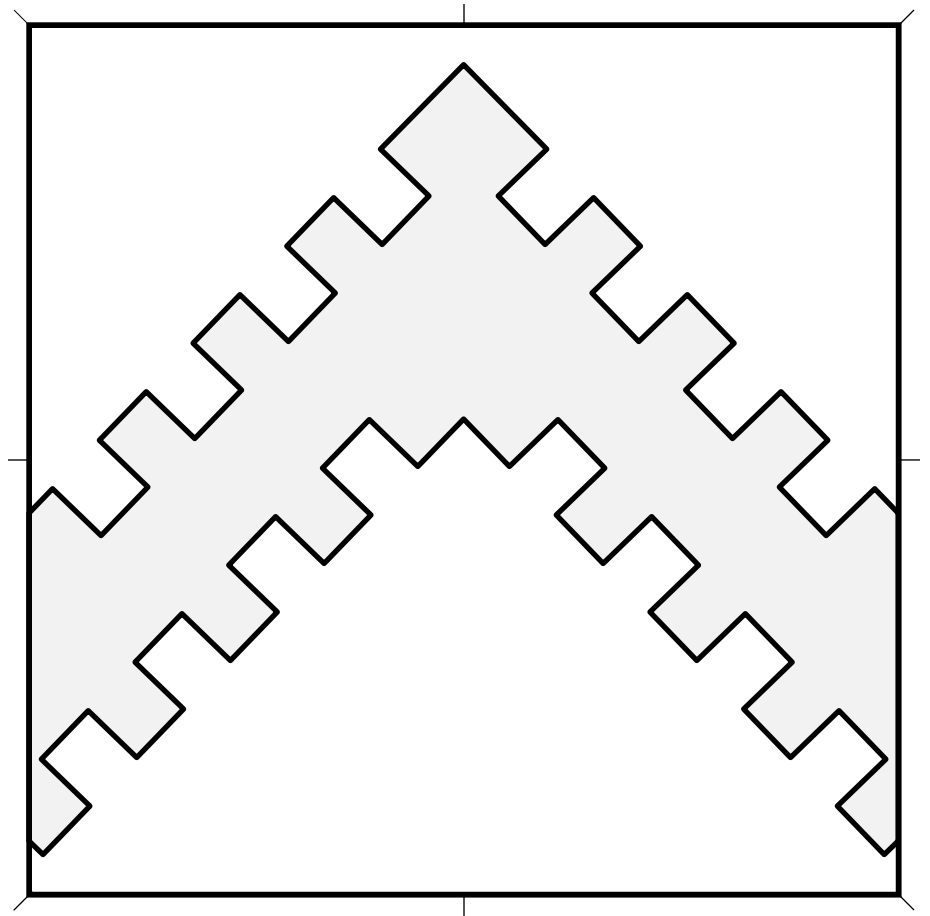
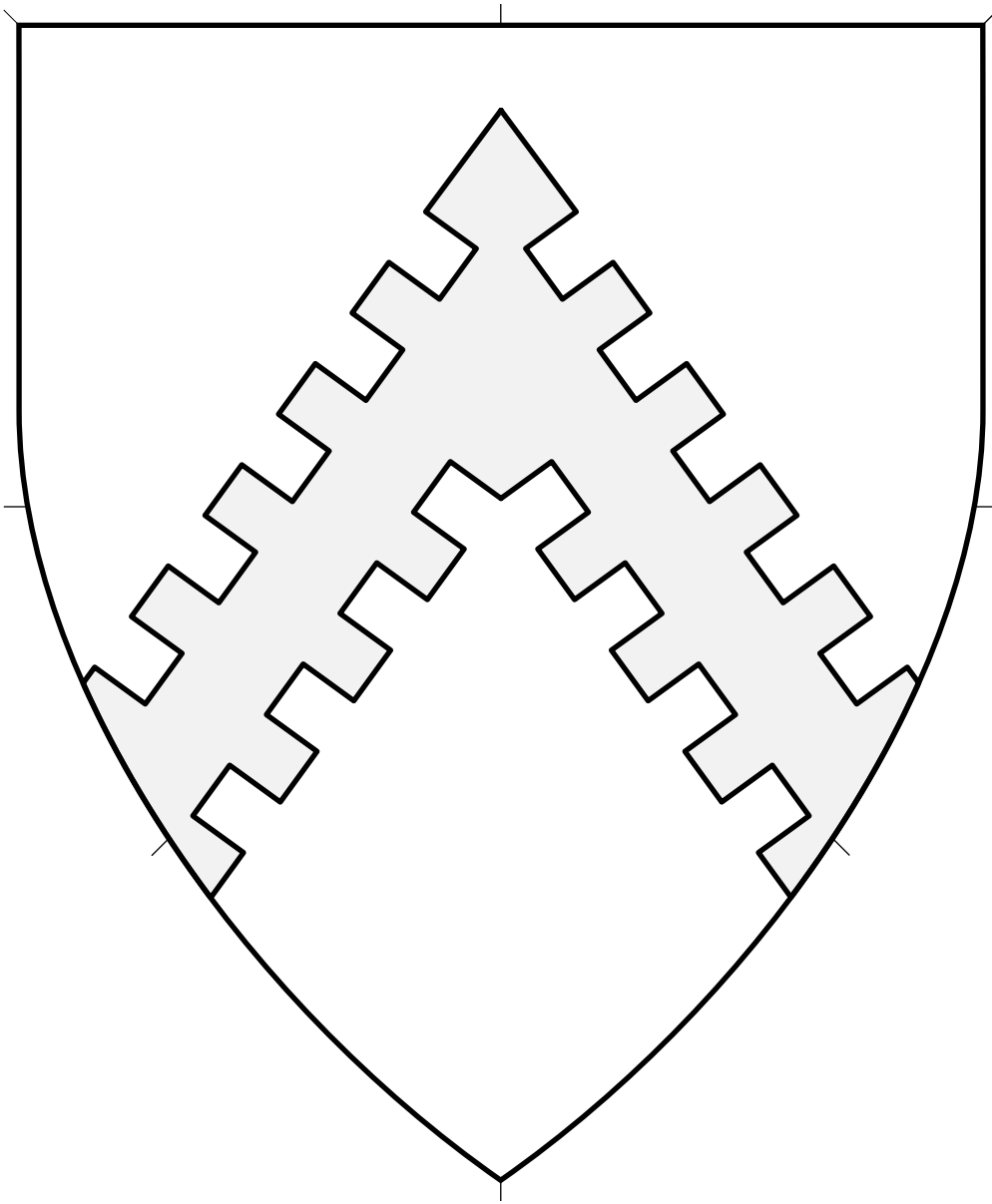

Central ordinary.

Source: Viking Answer Lady SVG Images For Heraldry. Artist: Gunnvôr silfráhr. Adapted by Mathghamhain Ua Ruadháin.

Chevron Embattled Counter-Embattled (1) 4.228

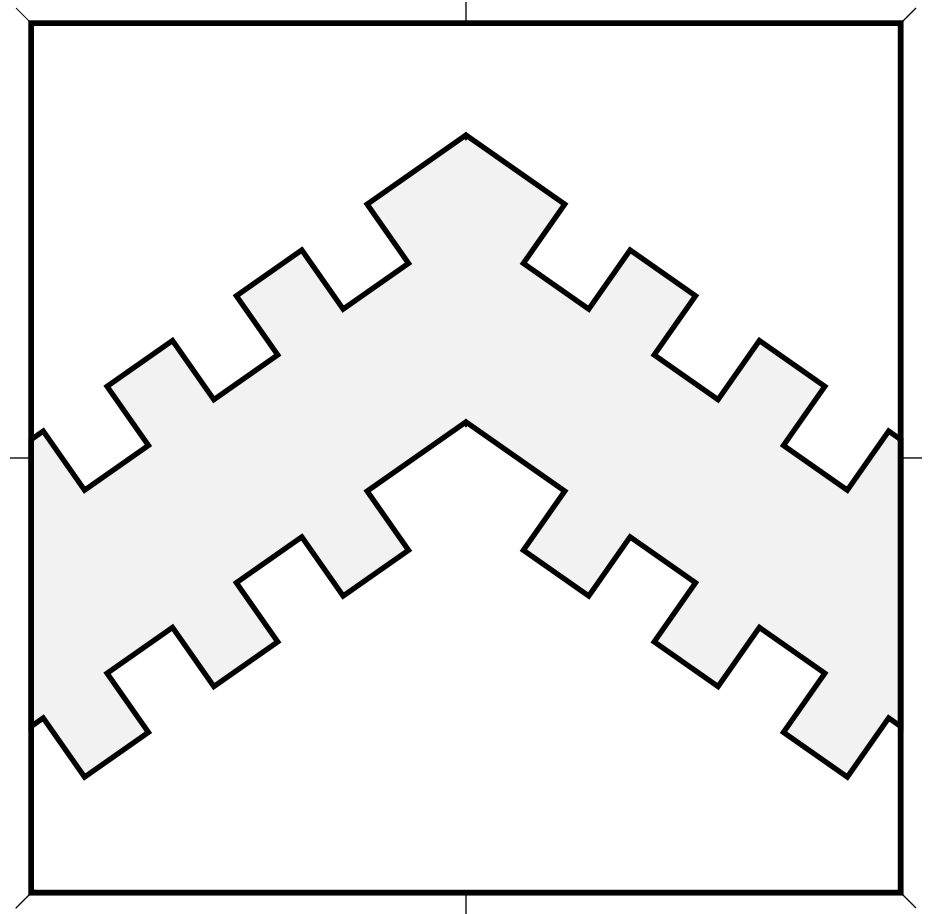
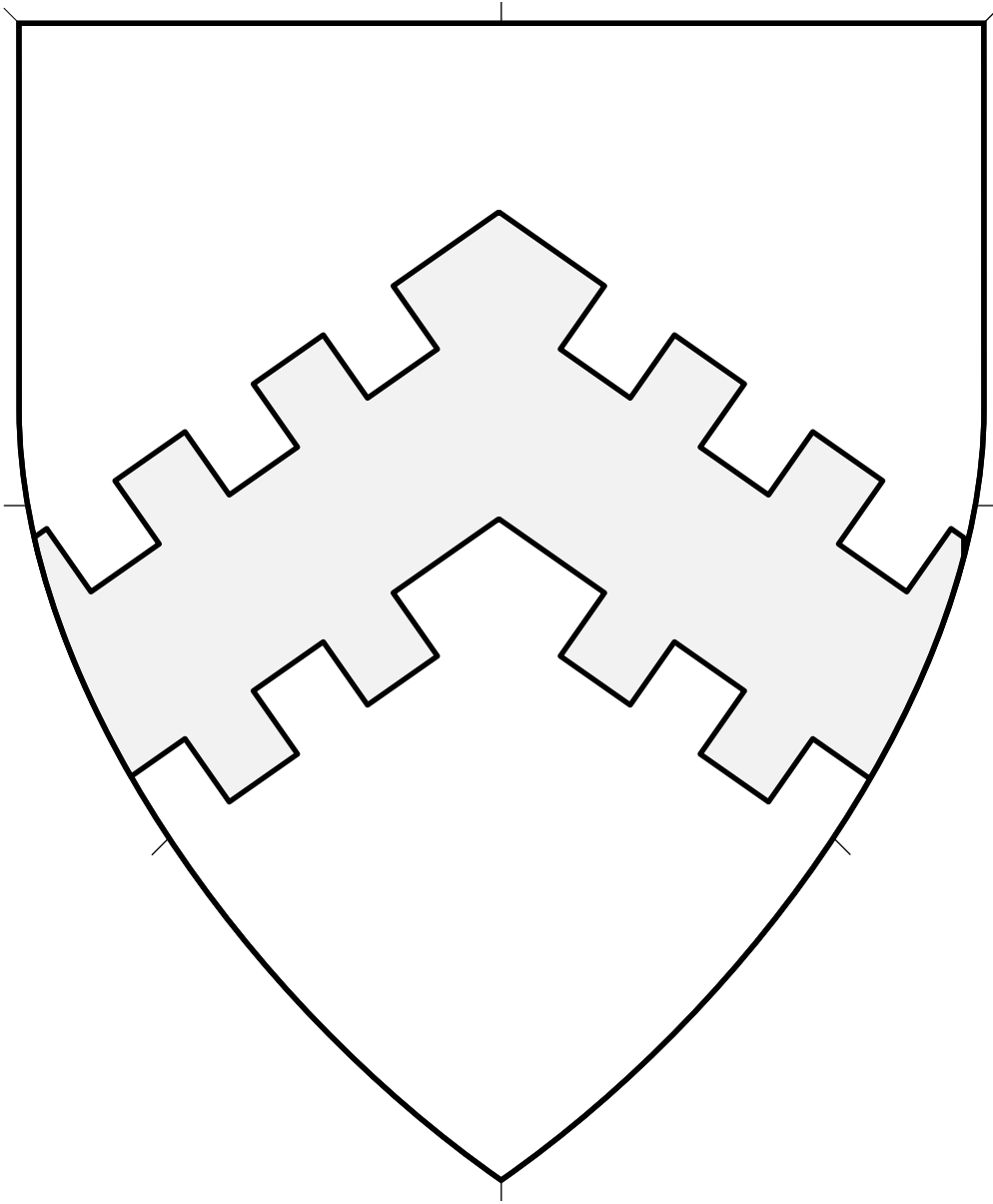

Central ordinary.

Chevron Embattled Counter-Embattled (2) 4.229

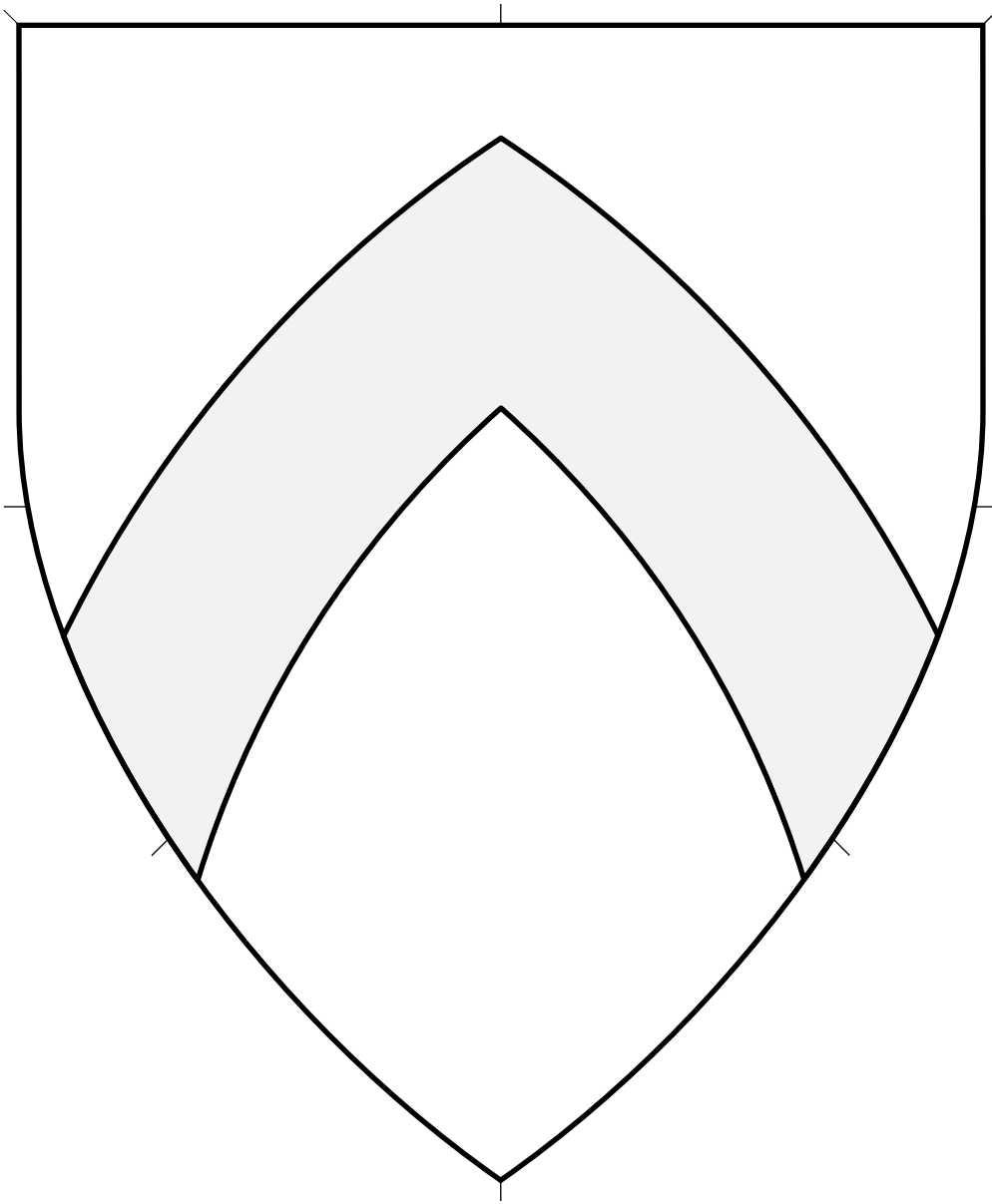

Central ordinary.

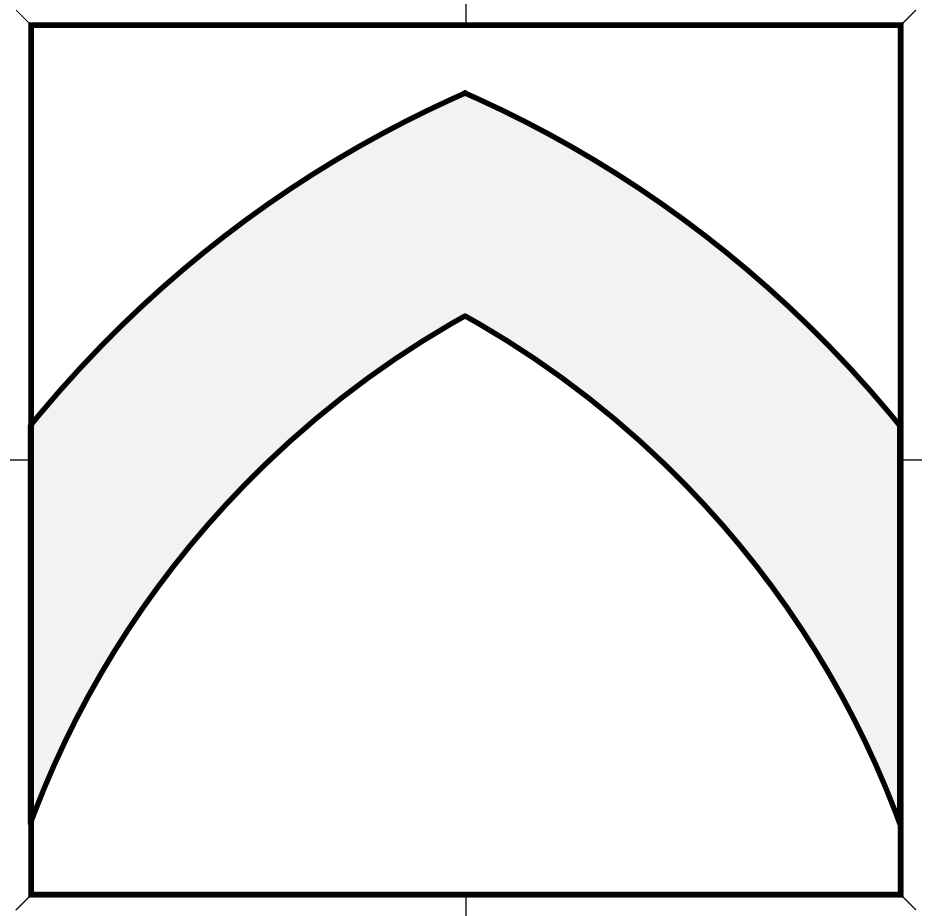

Chevron Enarched 4.230

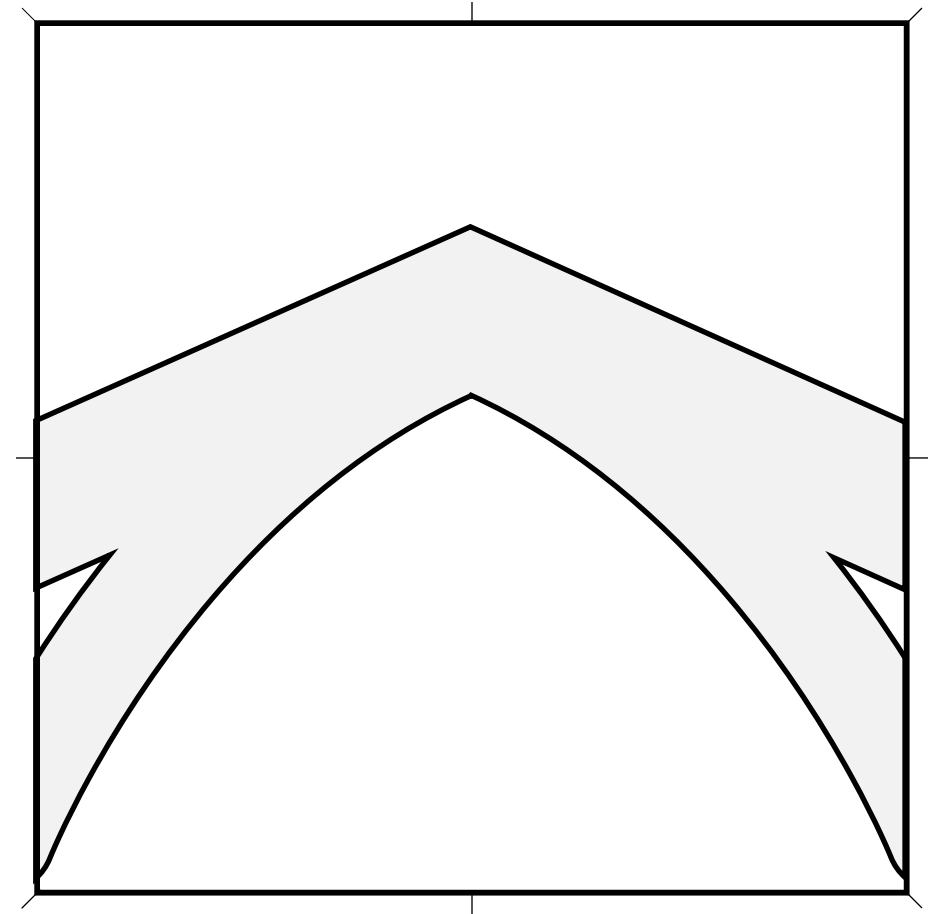
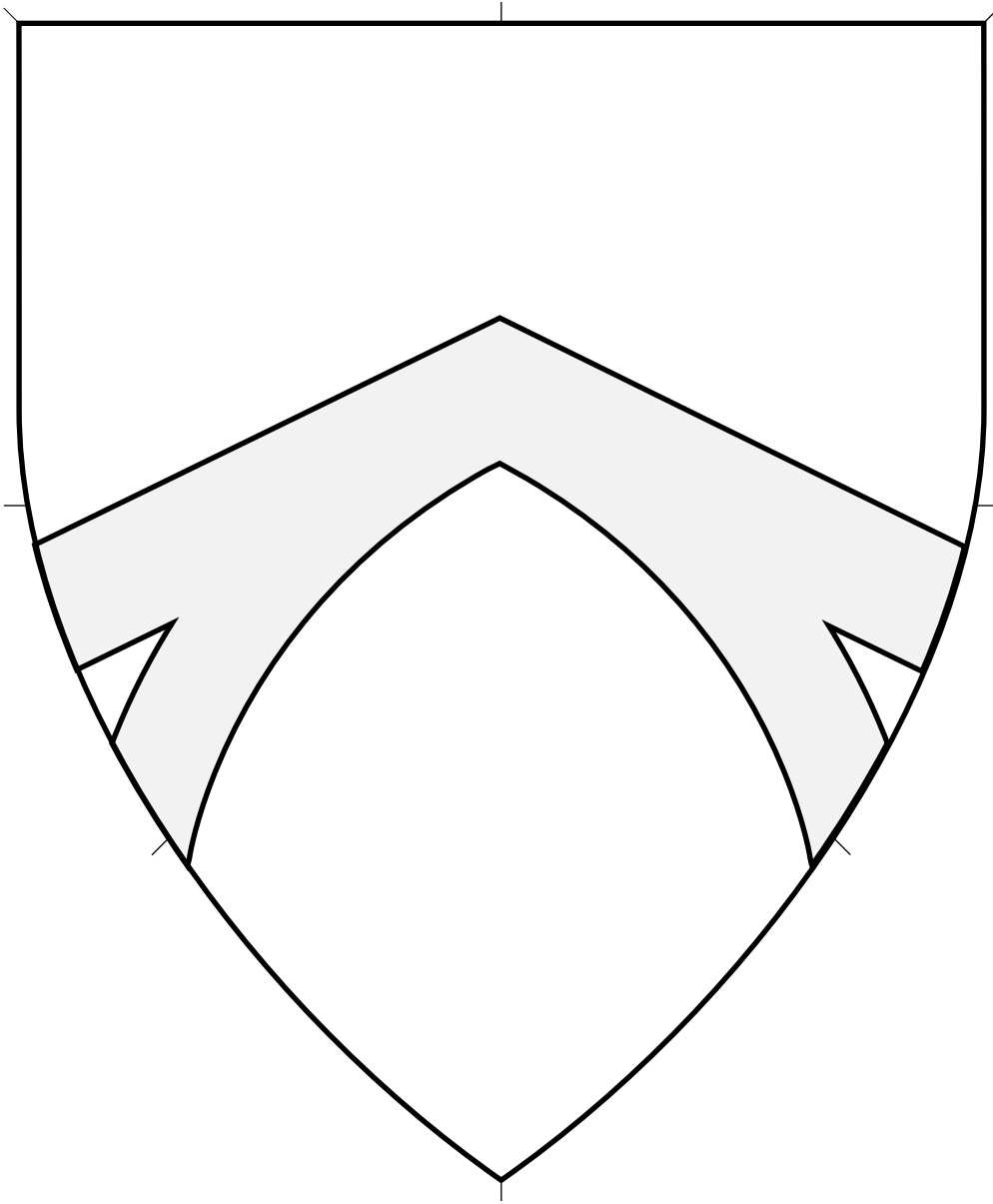

Central ordinary.

Source: The Accedence of Armorie. Artist unknown. (Folio 105v.)

Chevron Enarched Conjoined To A Chevron 4.231

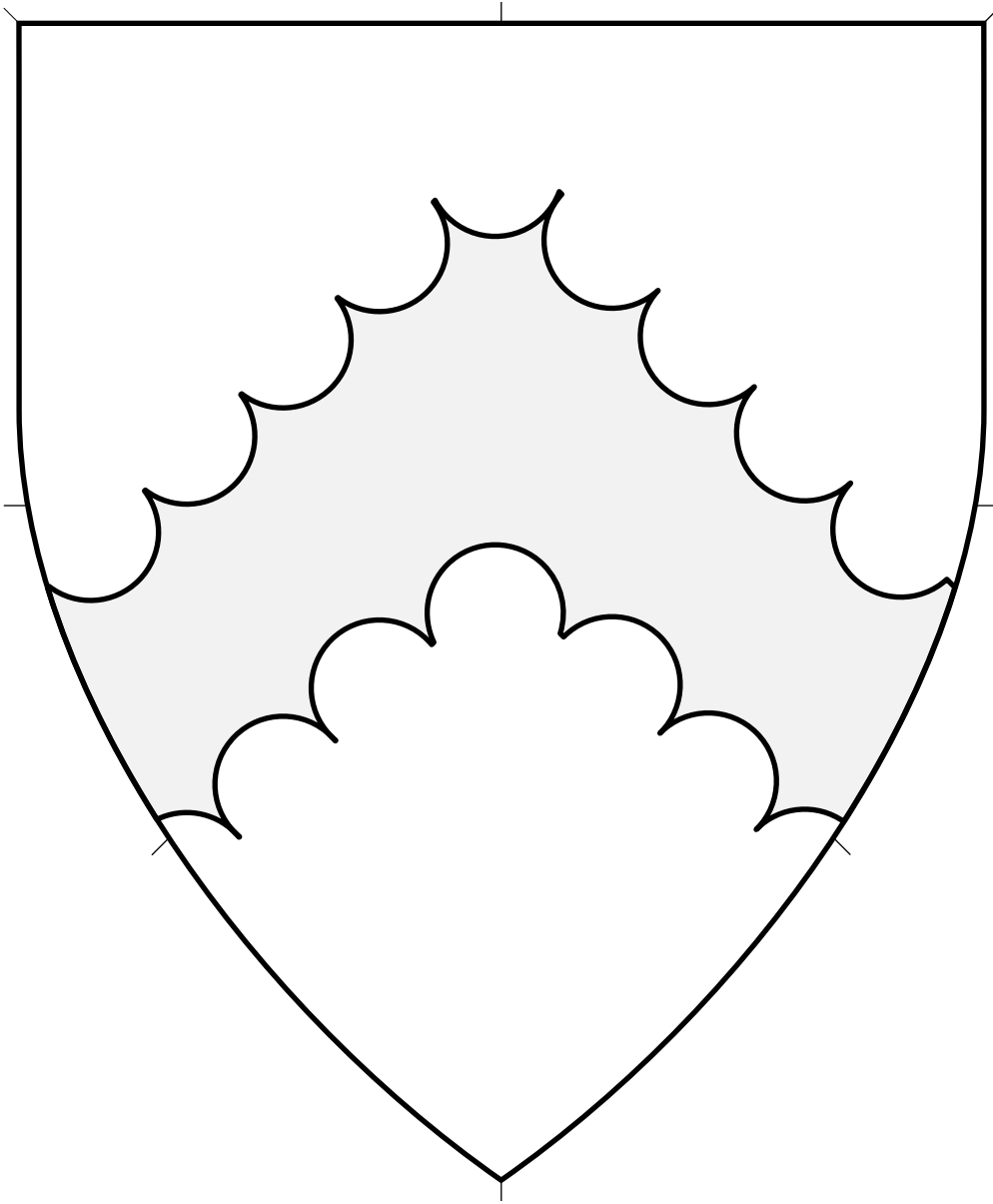

Central ordinary.

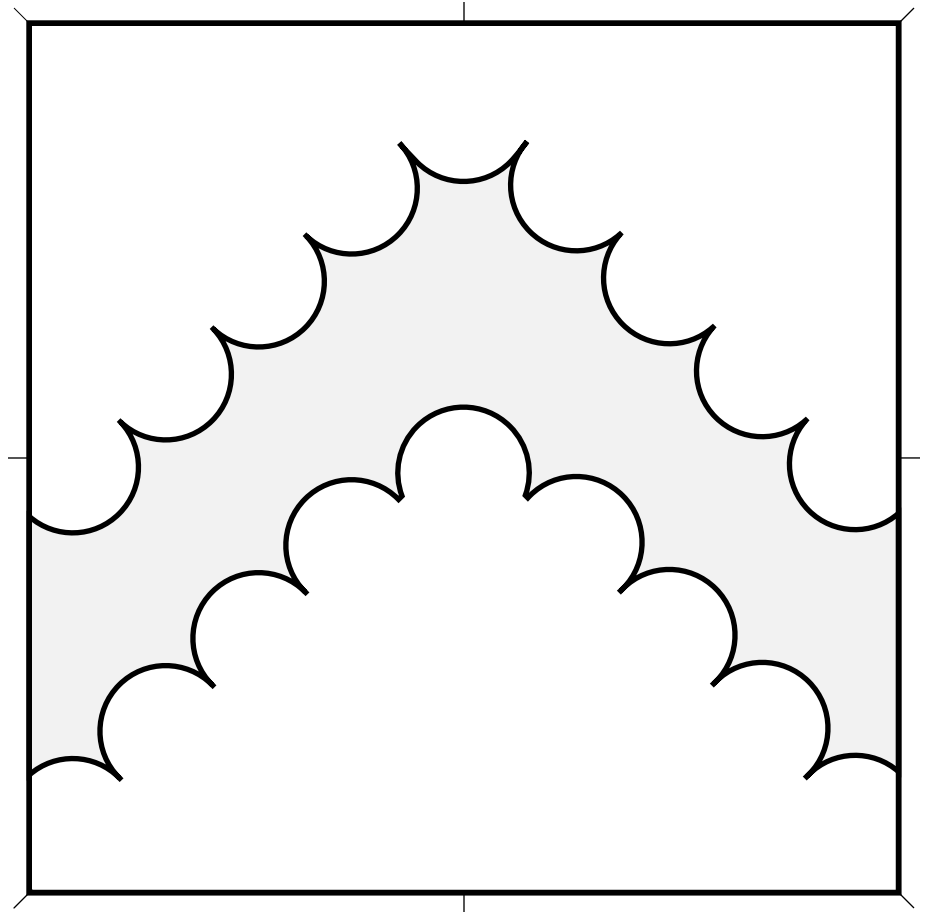

Chevron Engrailed (1) 4.232

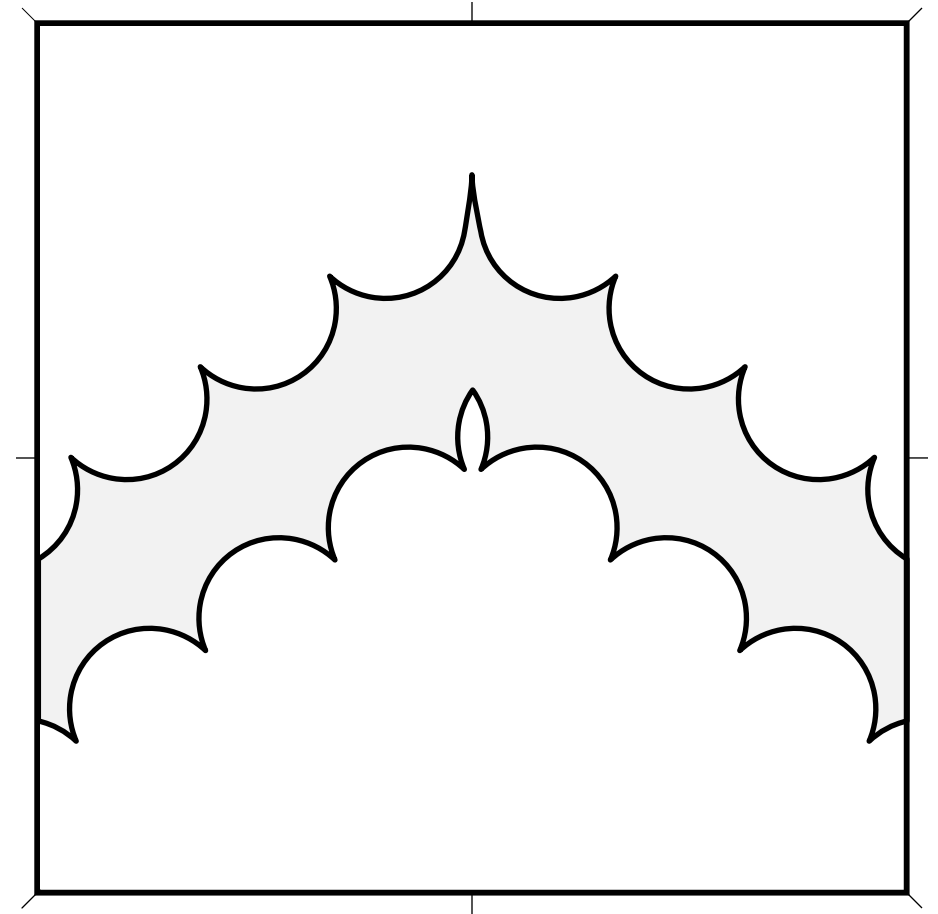
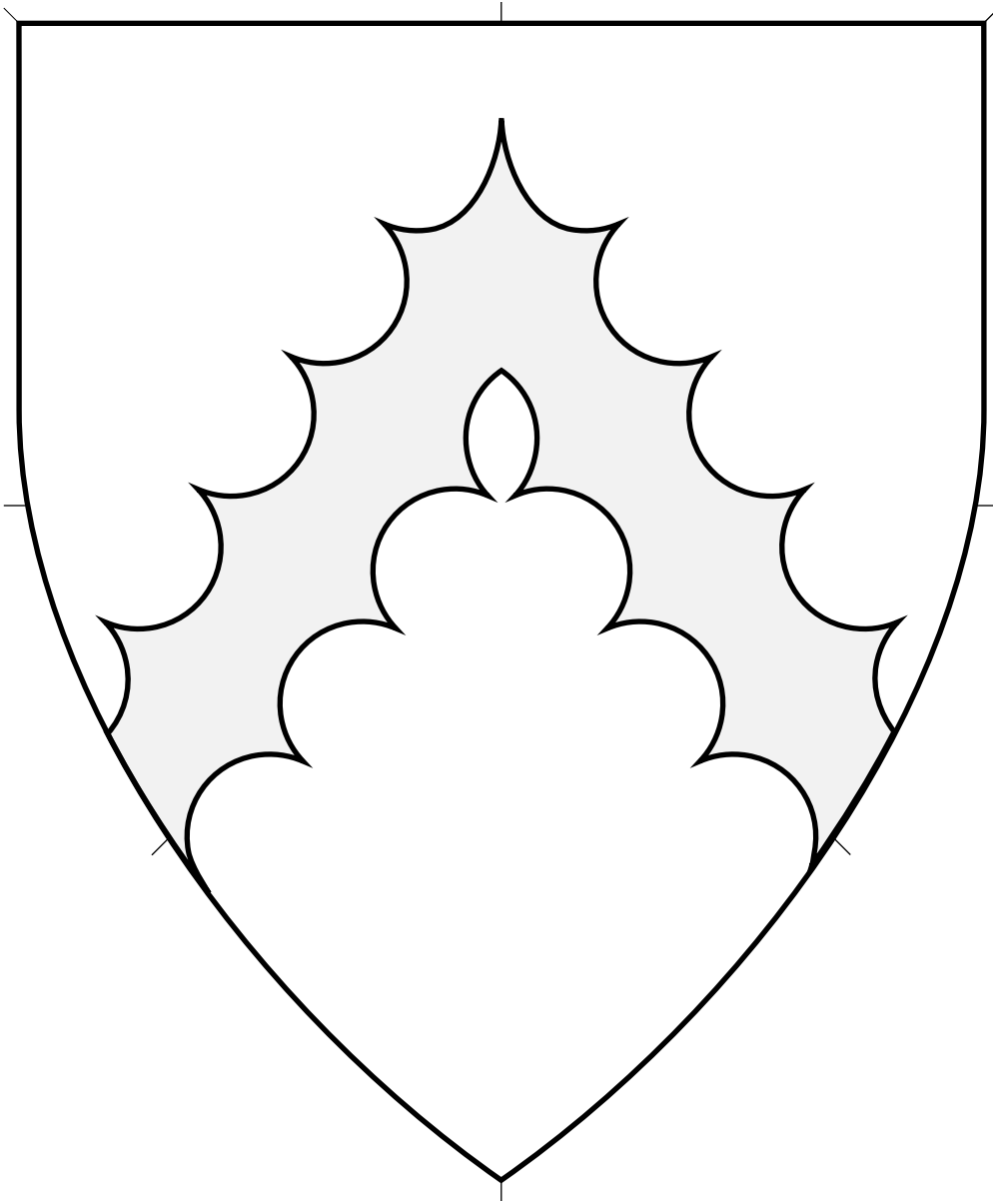

Central ordinary.

Source: Fenwick Roll. Artist unknown.
Adapted by Mathghamhain Ua Ruadháin.

Chevron Engrailed (2) 4.233

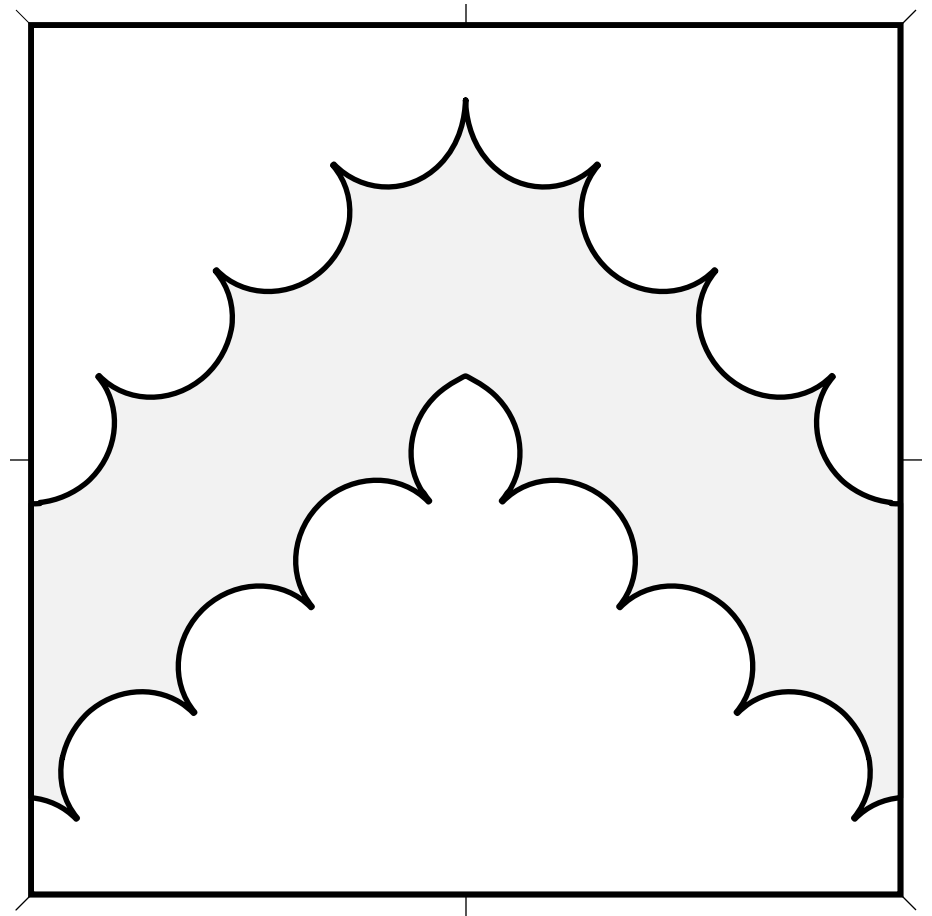
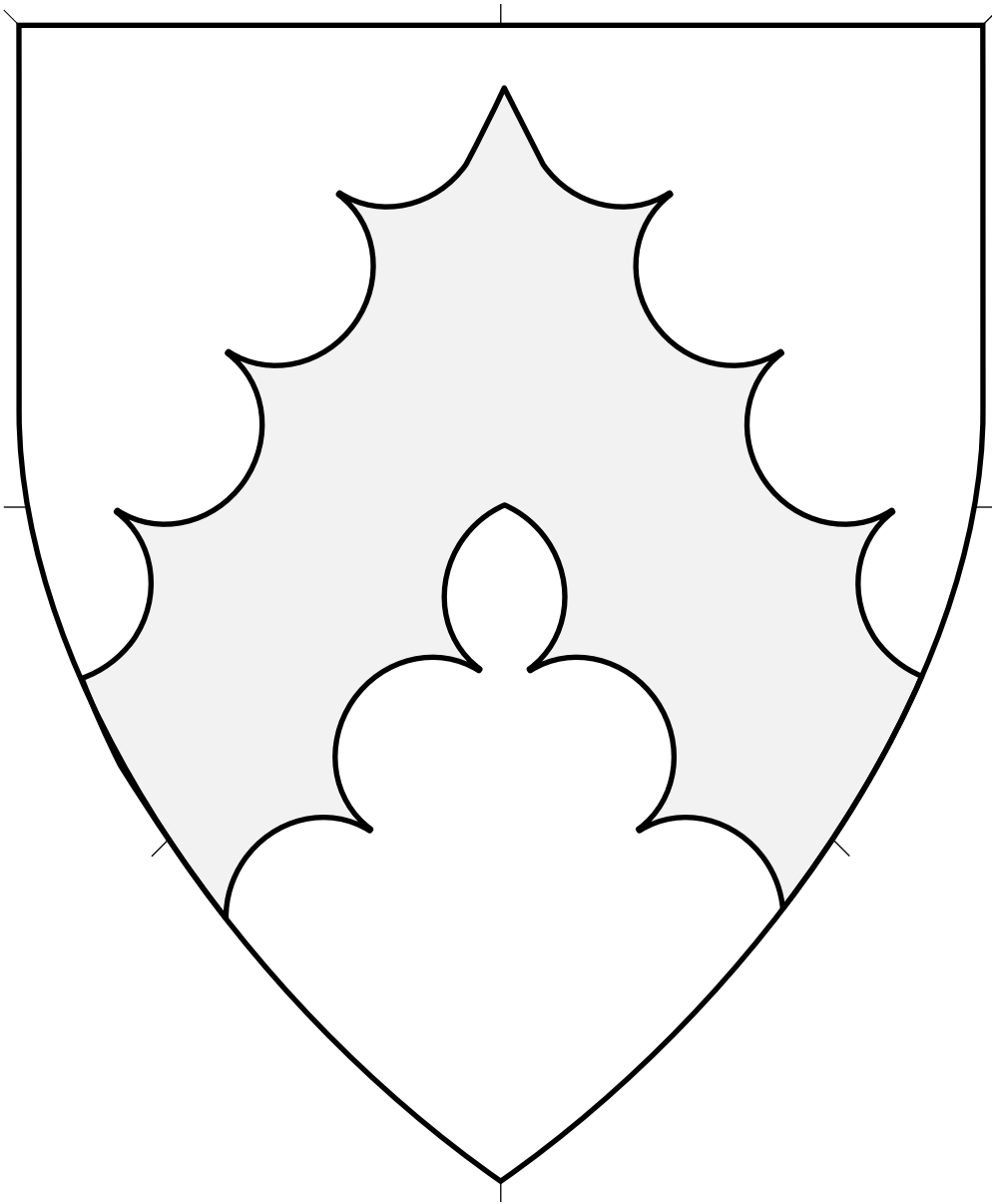

Central ordinary.

Source: Viking Answer Lady SVG Images For Heraldry. Artist: Gunnvôr silfráhr. Adapted by Mathghamhain Ua Ruadháin.

Chevron Engrailed (3) 4.234

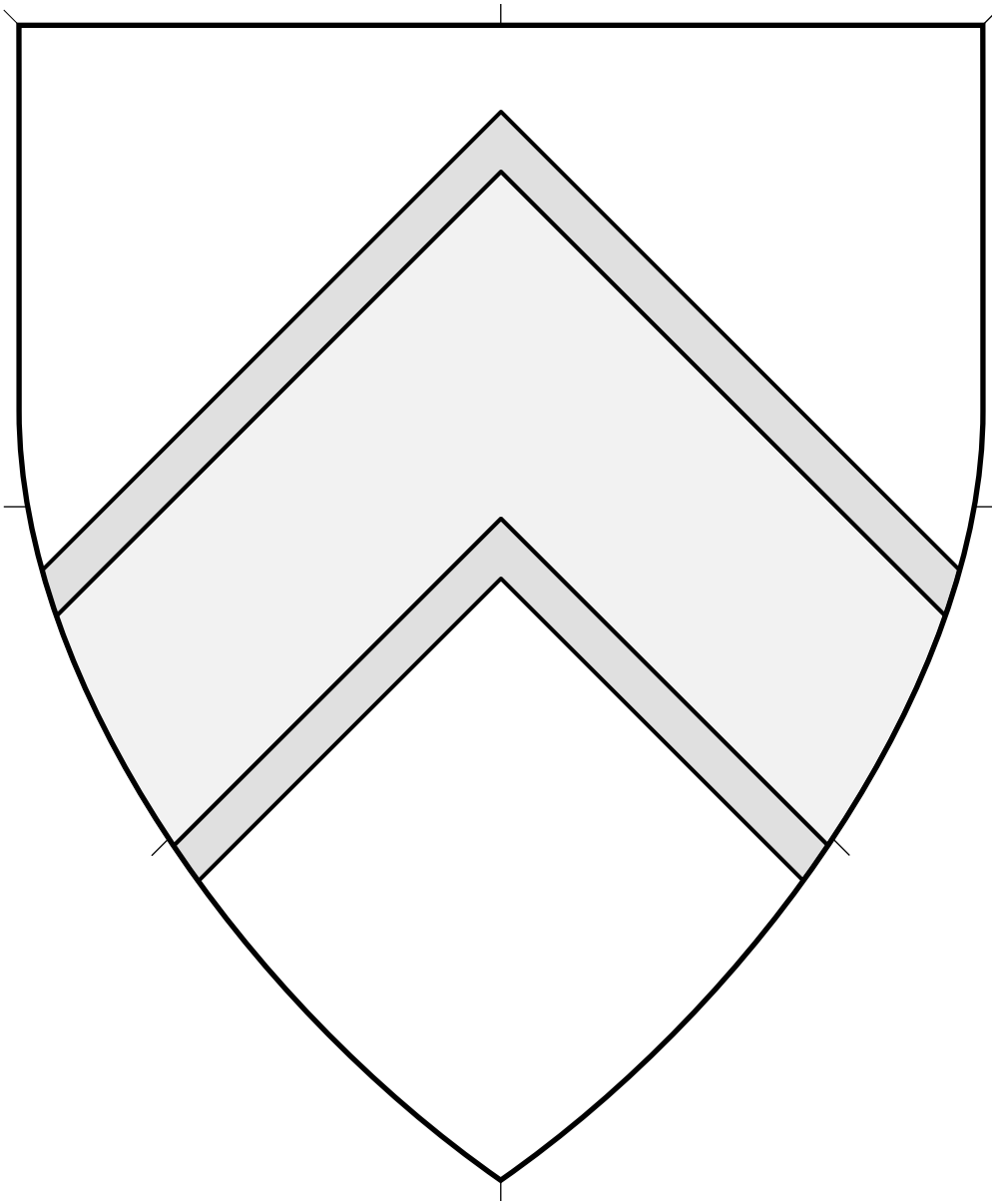

Central ordinary.

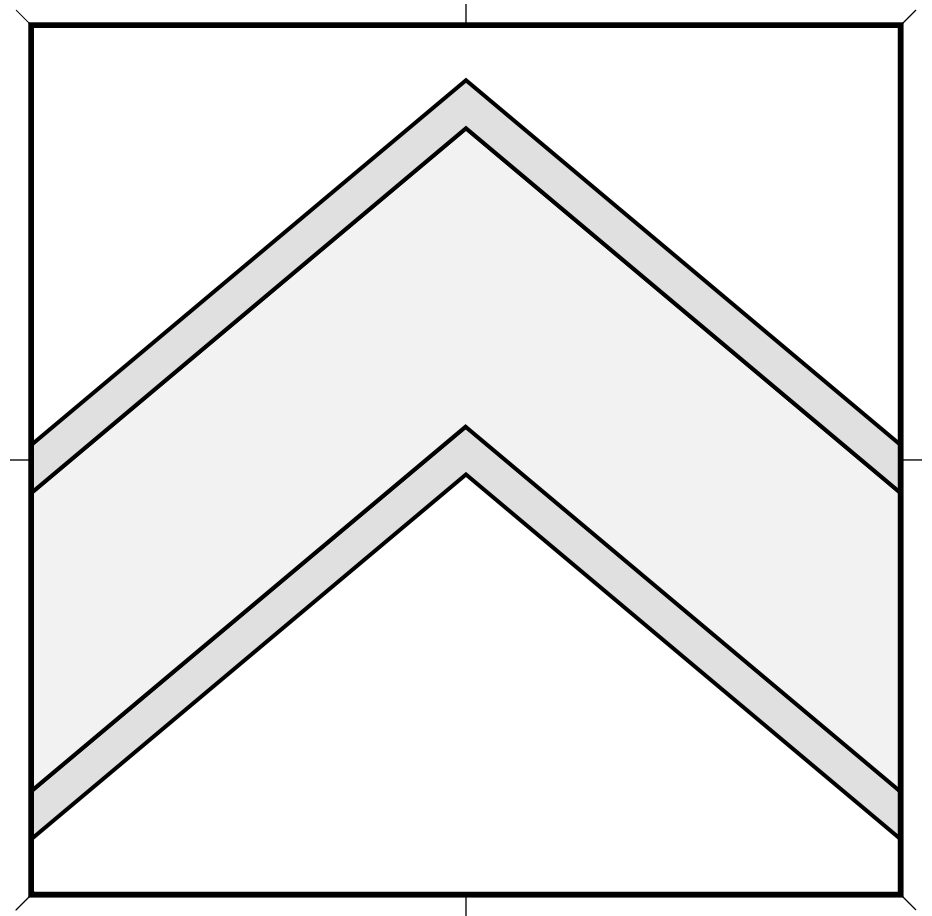

Chevron Fimbriated 4.235

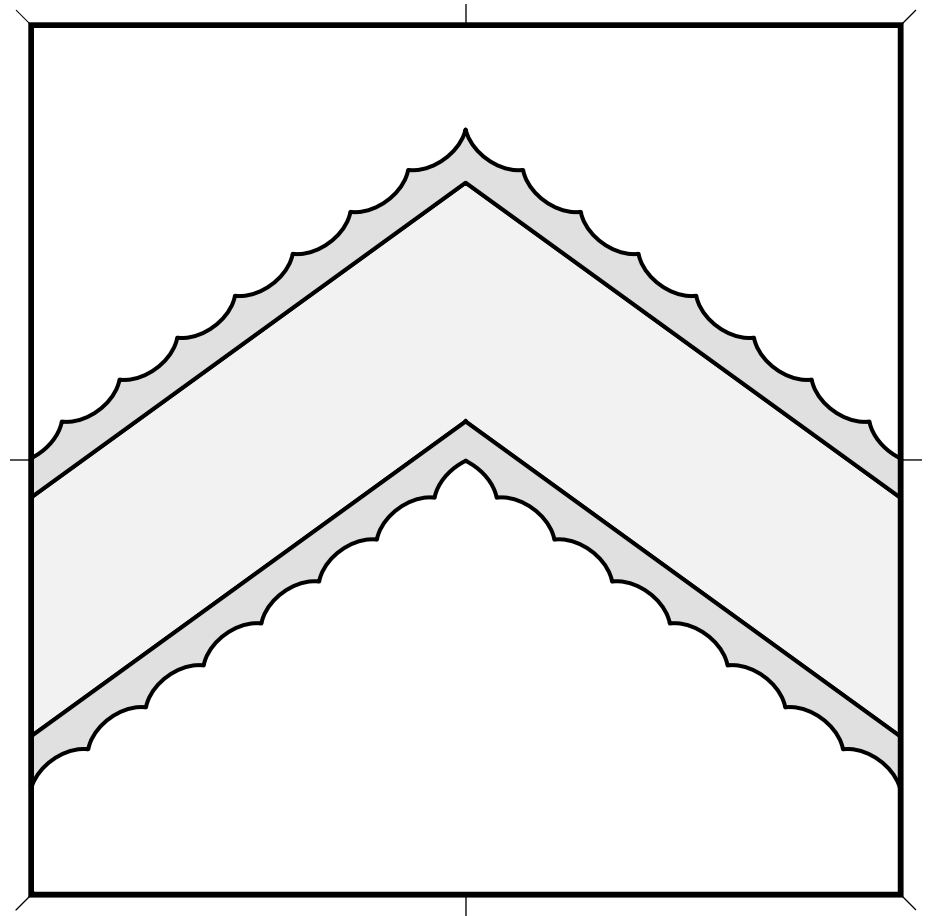
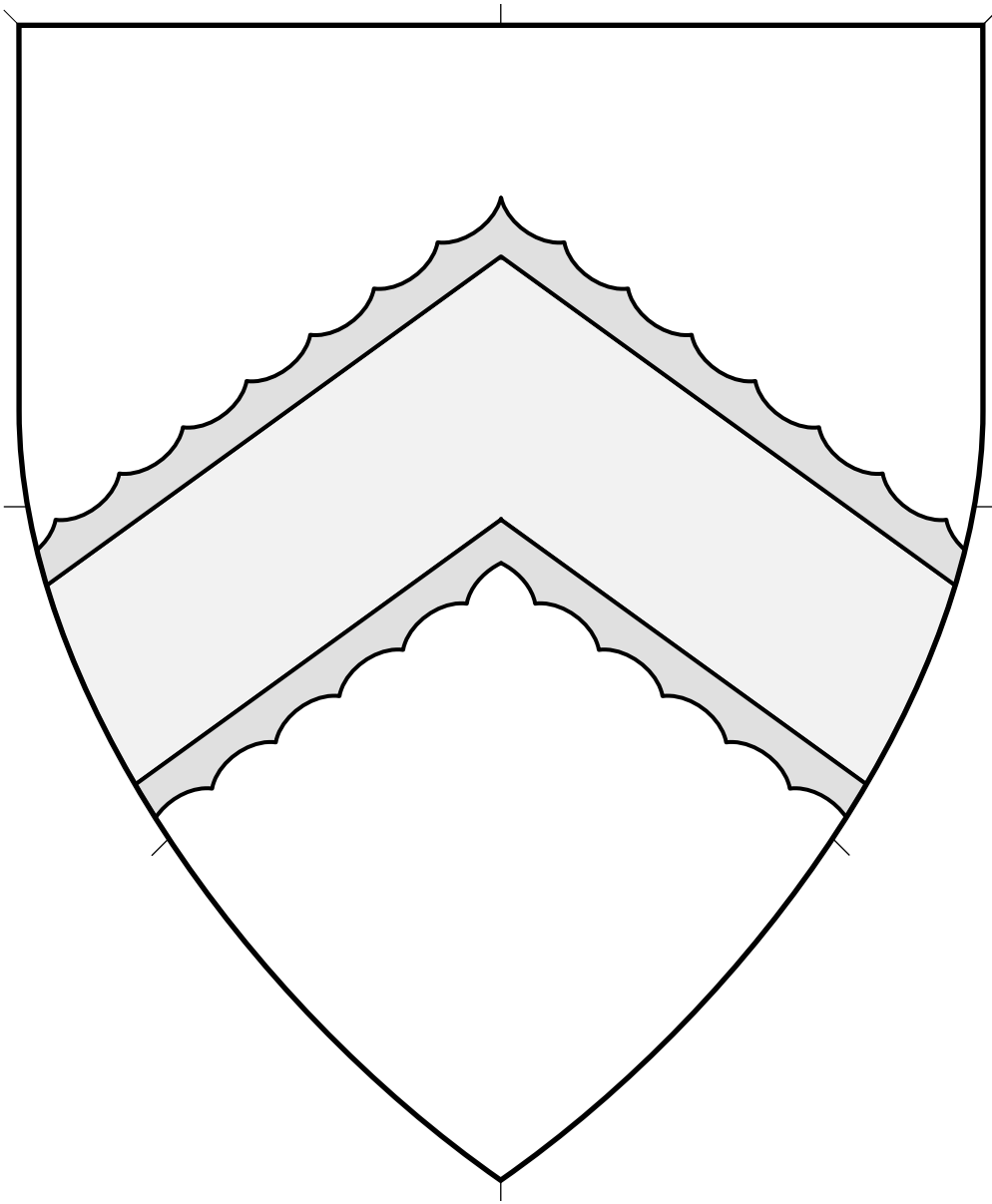

Central ordinary.

Source: Insignia Anglica. Artist unknown.

Chevron Fimbriated Engrailed 4.236

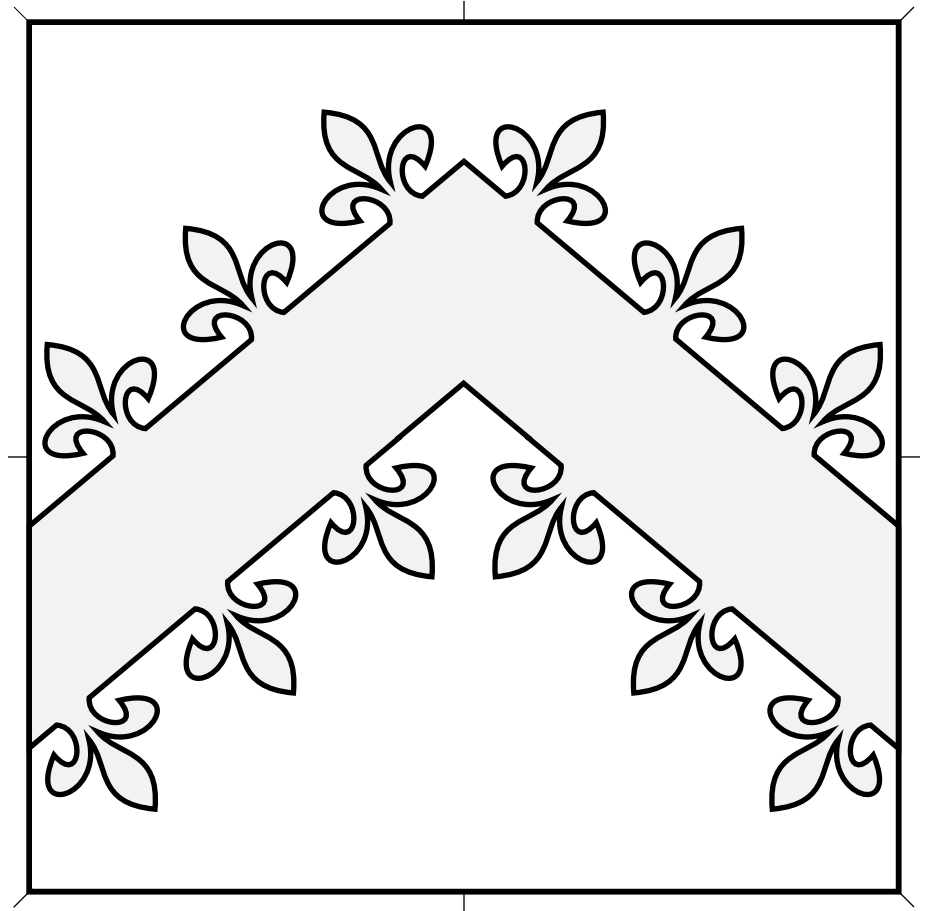
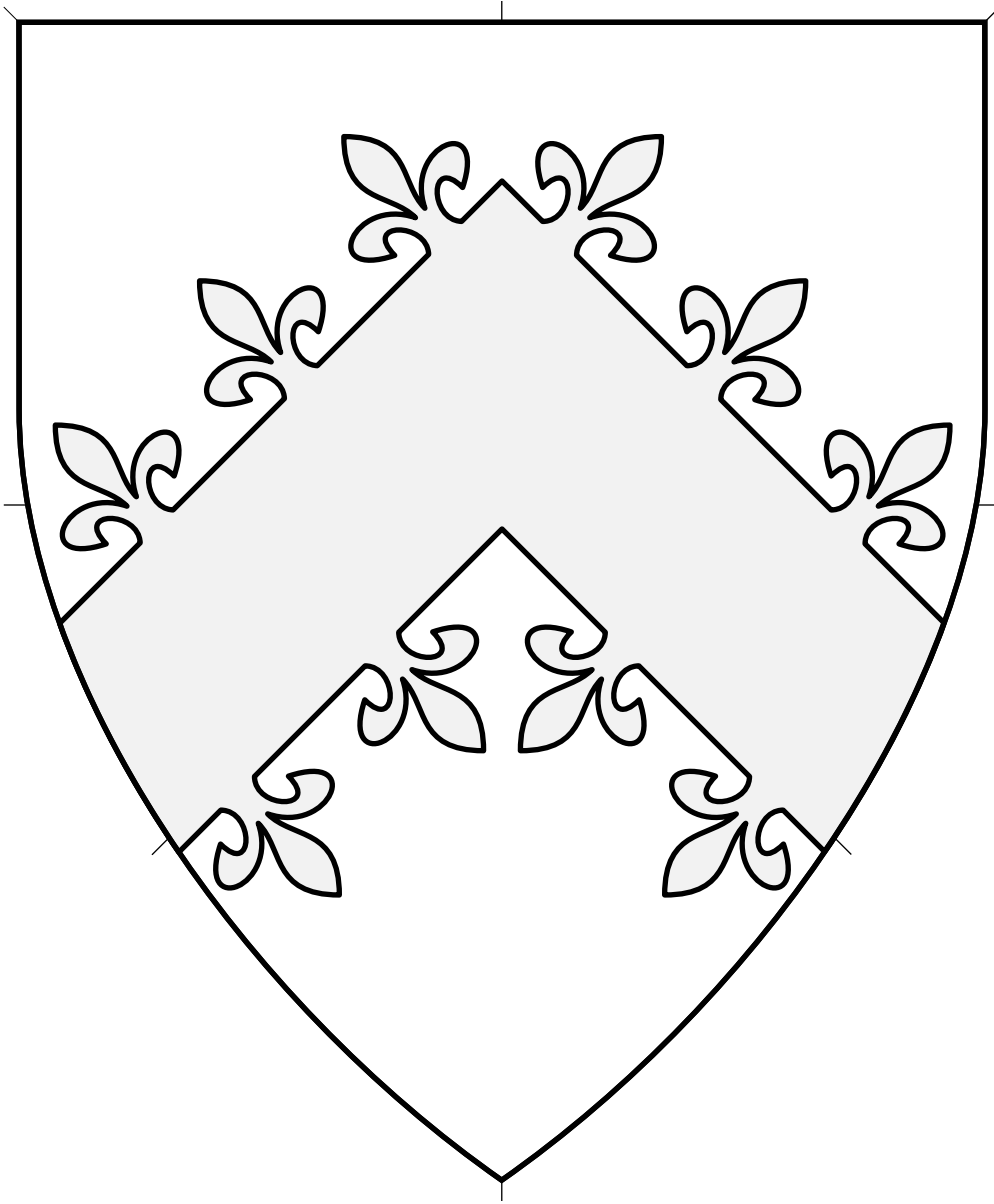

Central ordinary.

Combining a central ordinary flory with other charges would be a Step from Core Practice (SFCP).

Chevron Flory 4.237

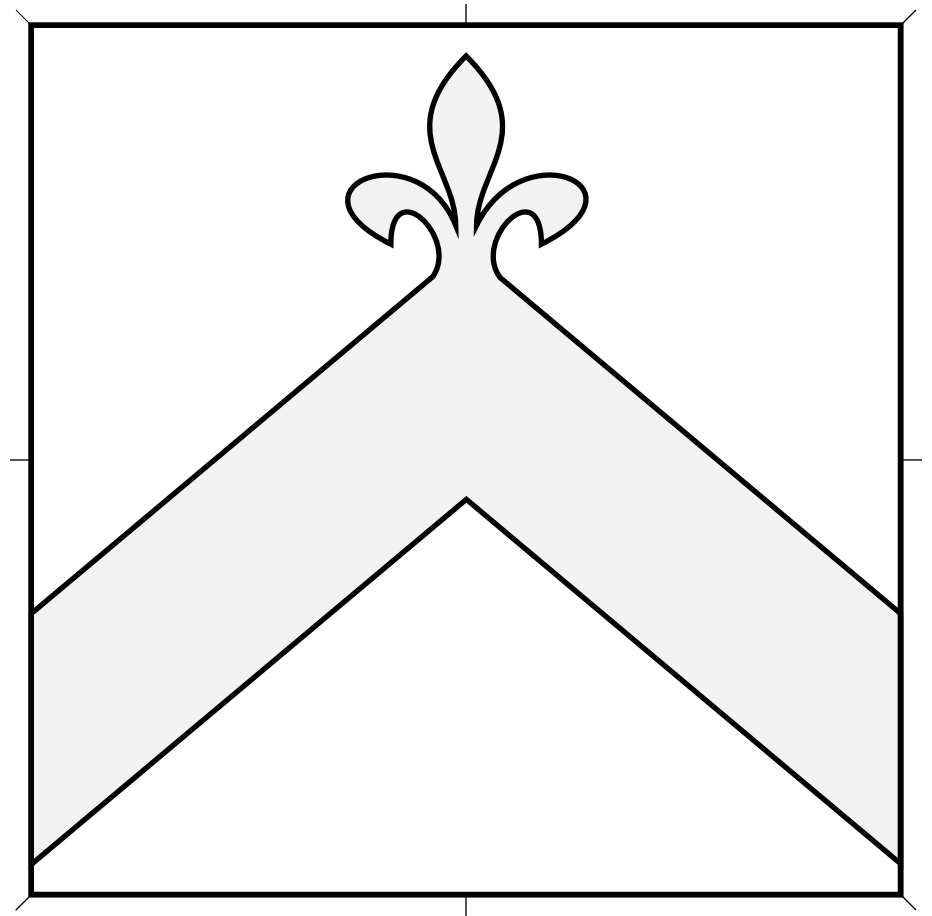
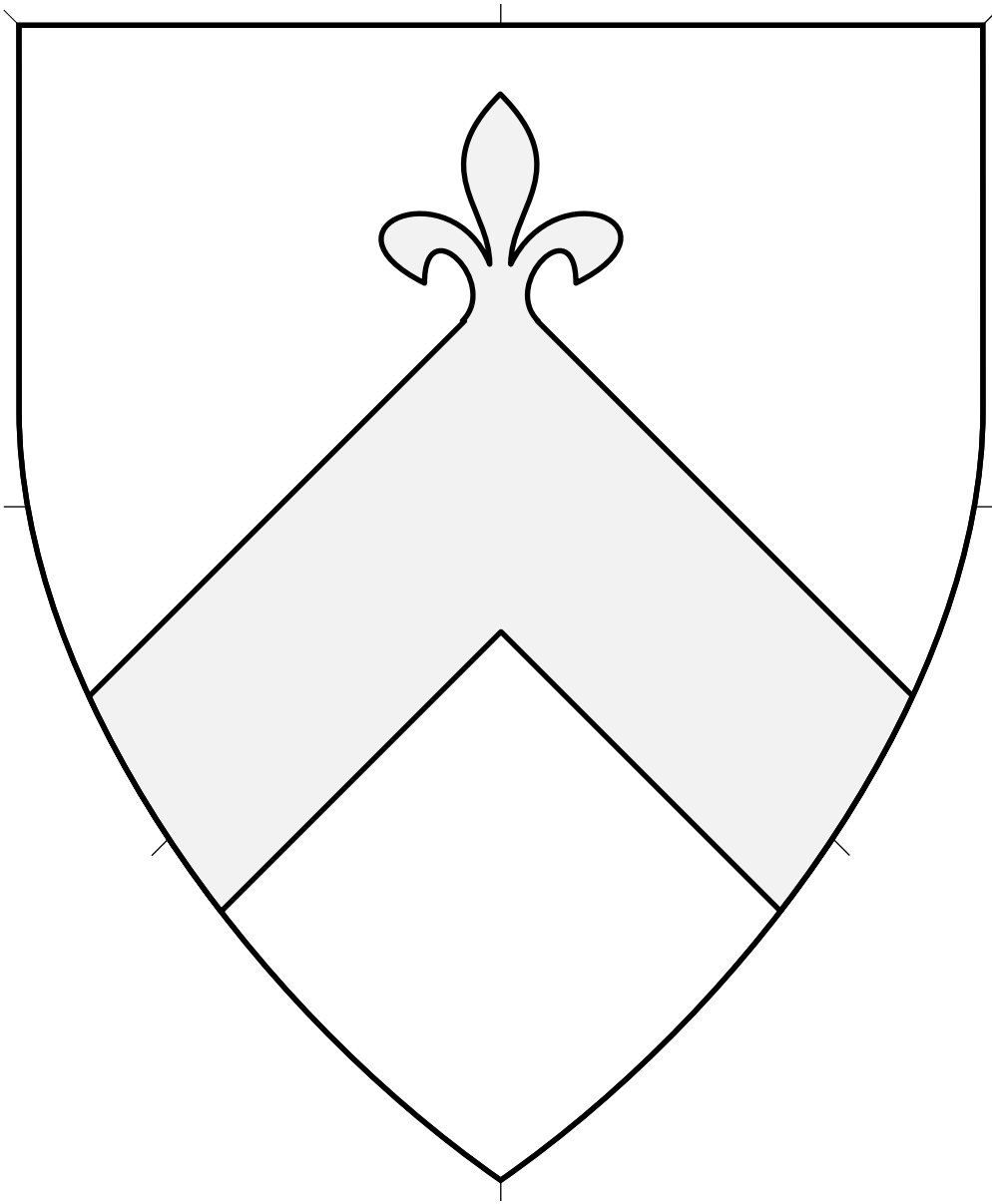

Central ordinary.

Chevron Flory at the Point 4.238

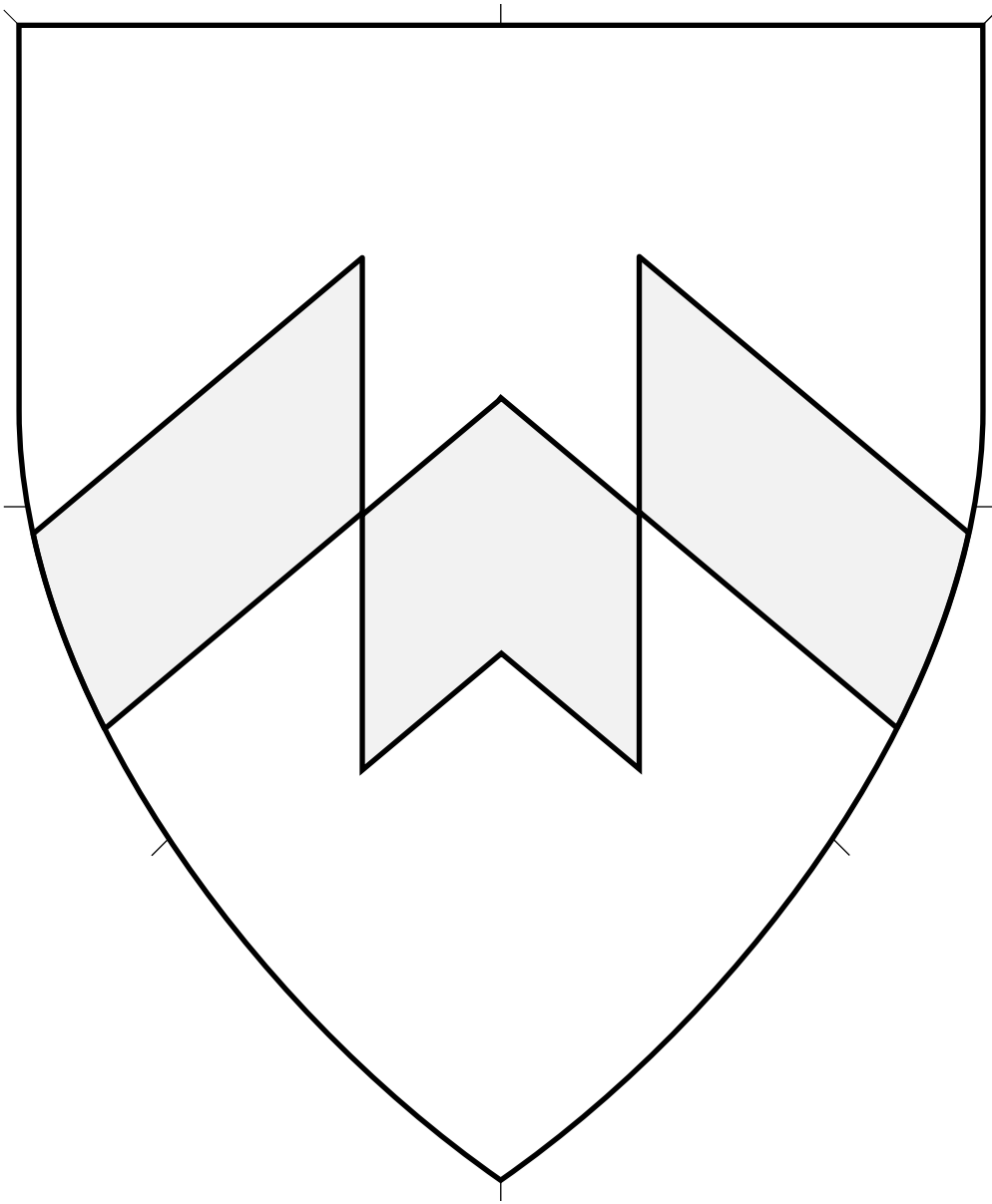

Central ordinary.

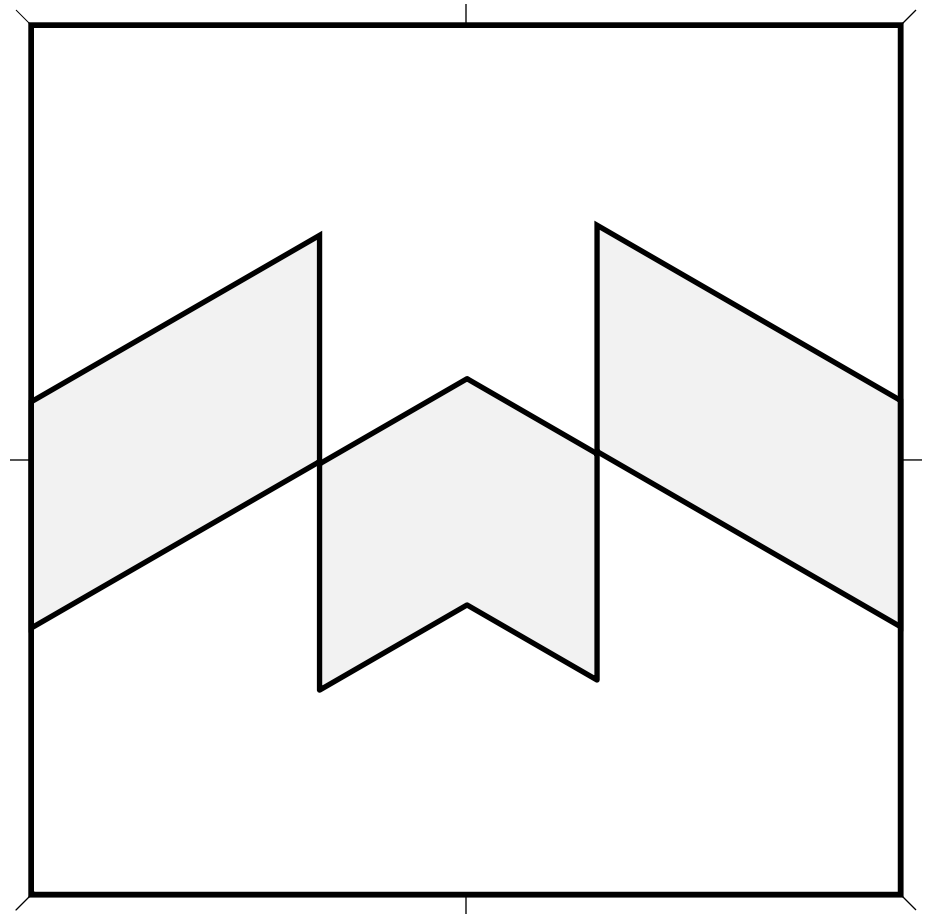

Chevron Fracted 4.239

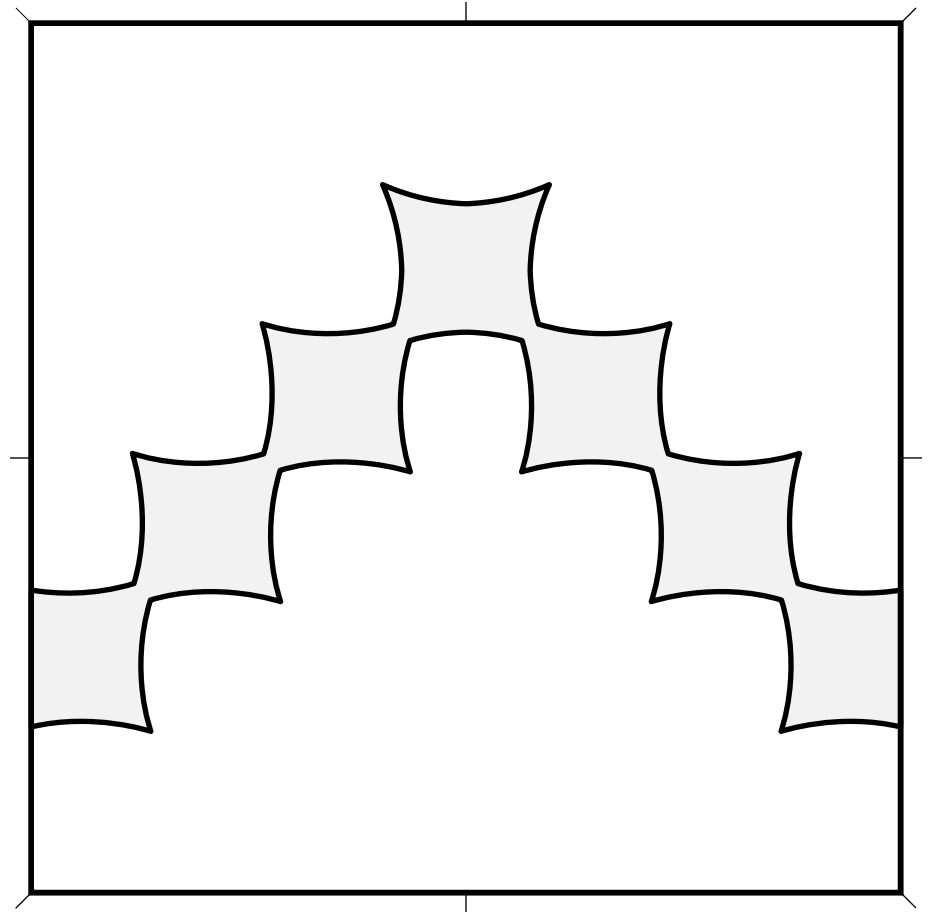
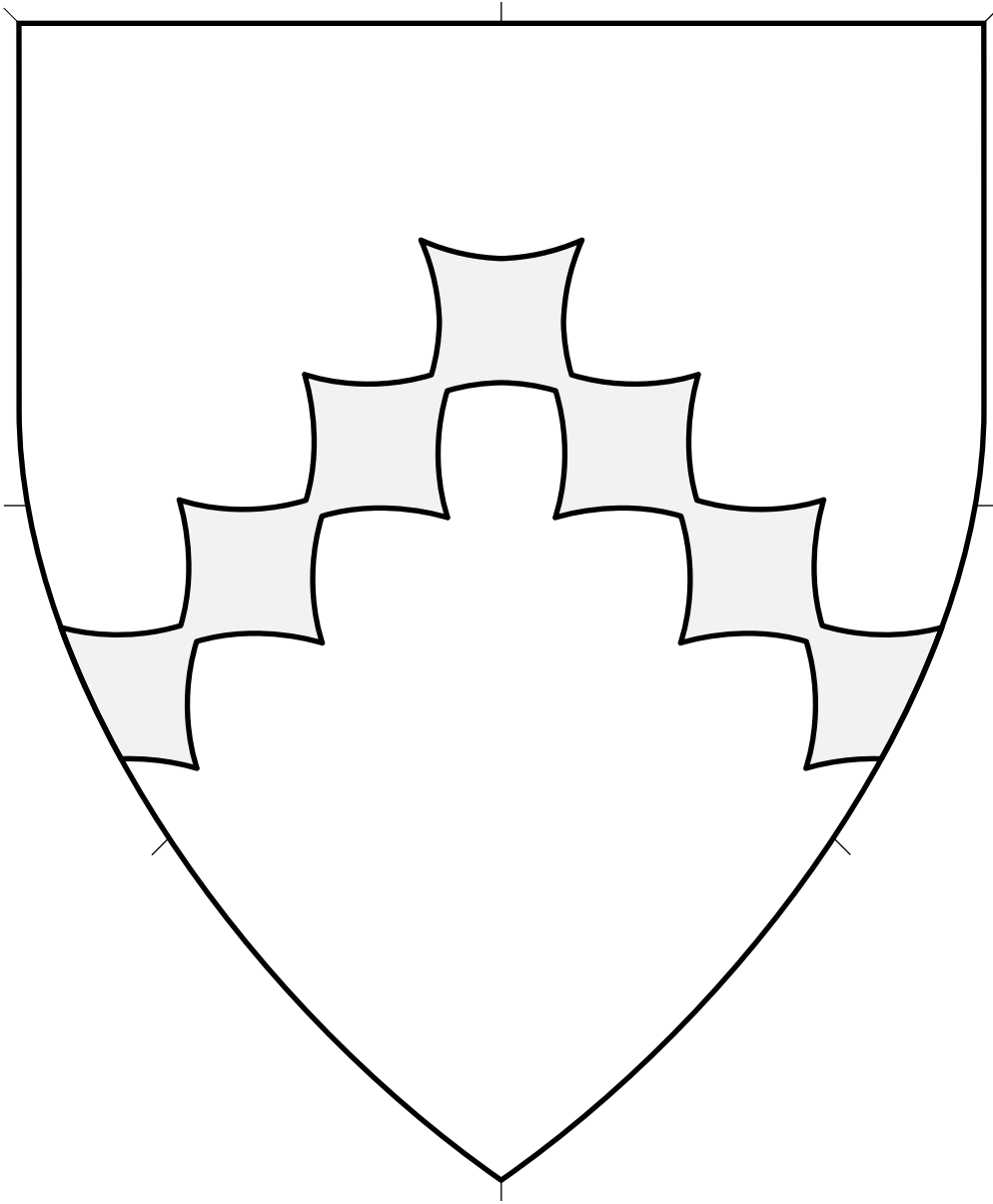

Central ordinary.

Source: Armorial de Gelre. Artist: Claes Heinenzoon. (Page 221.)
Adapted by Mathghamhain Ua Ruadháin.

Chevron Fusilly 4.240

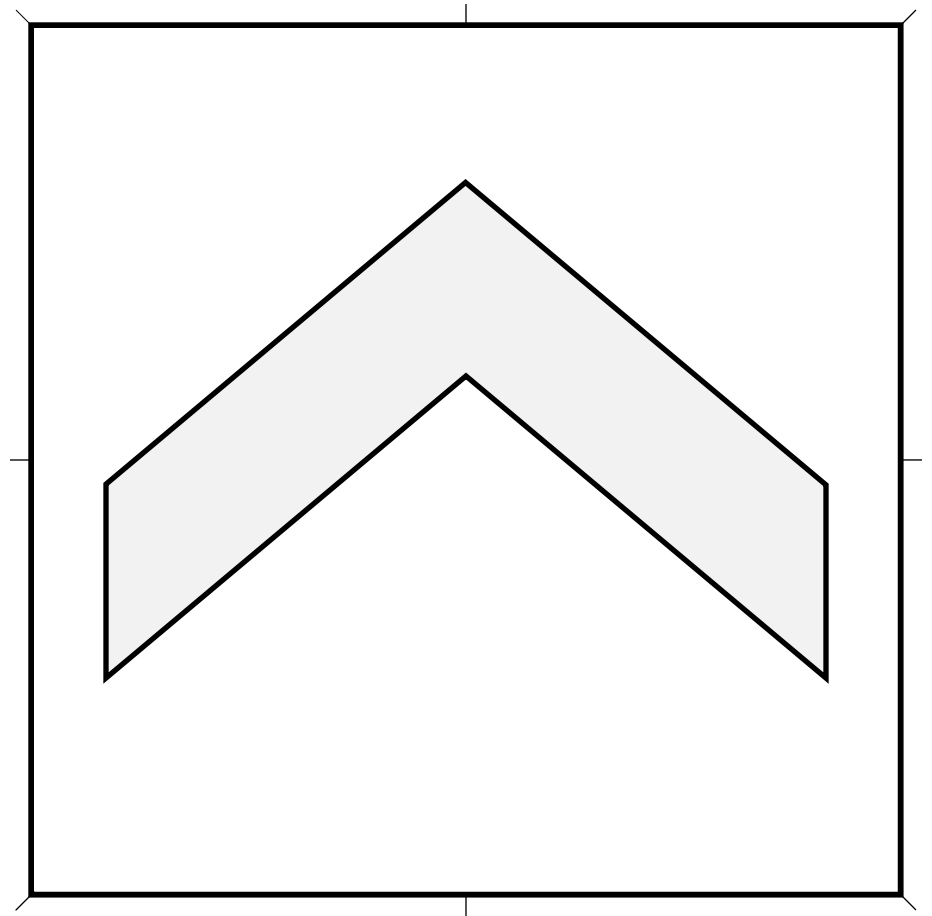
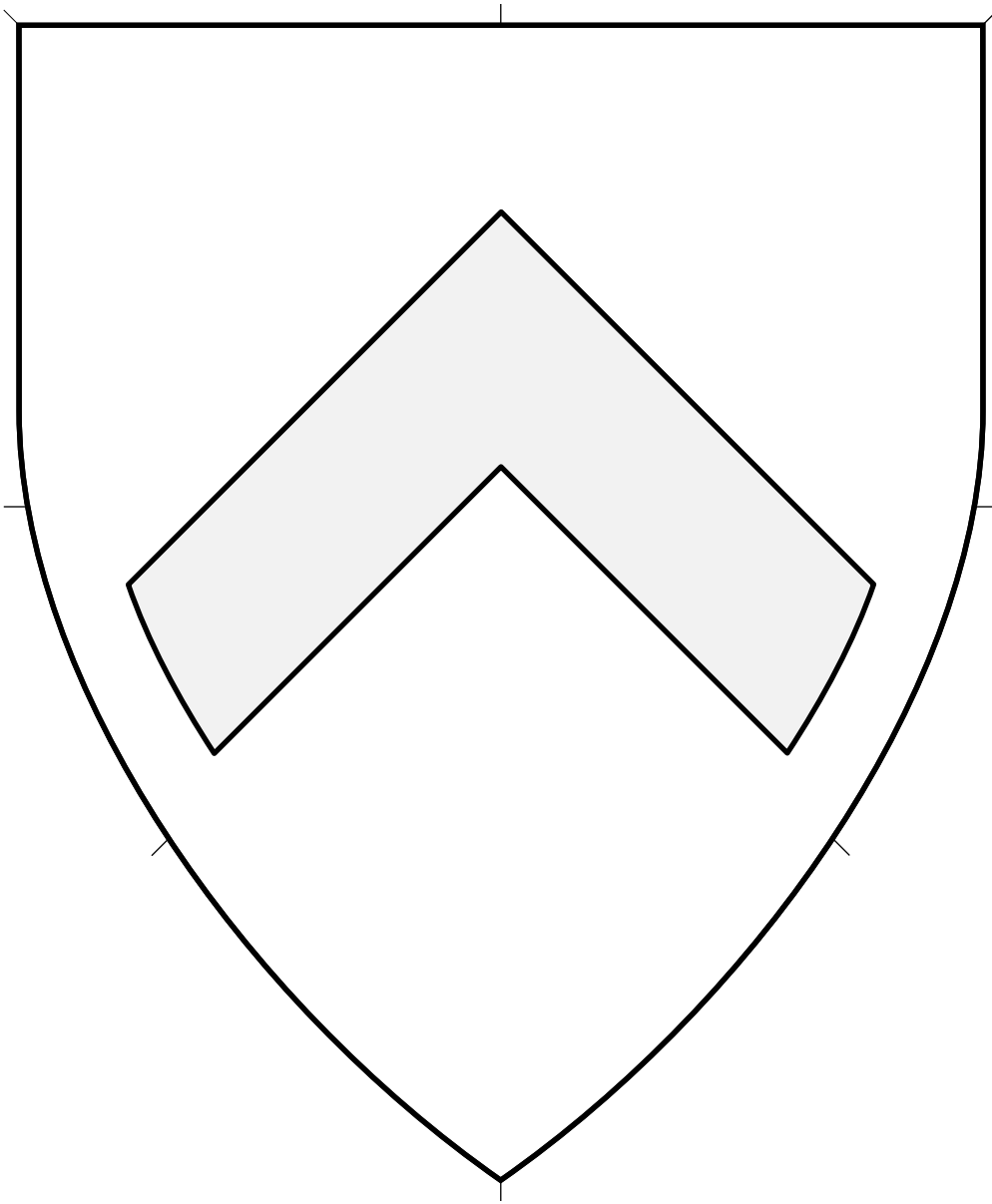

Central ordinary. The term "humetty" indicates that edges of the ordinary are couped parallel to the border of the field.

Chevron Humetty • 4.241

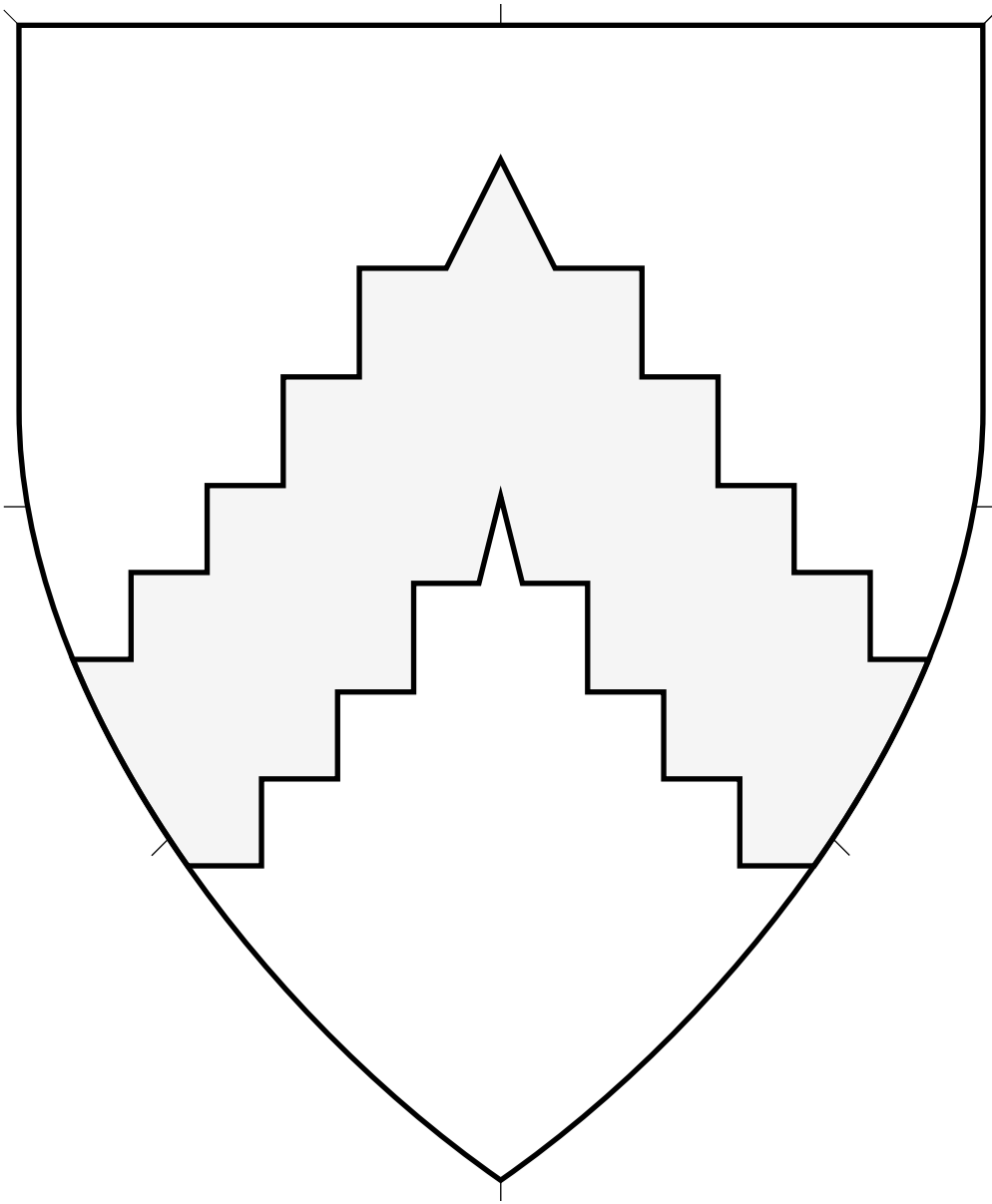

Central ordinary.

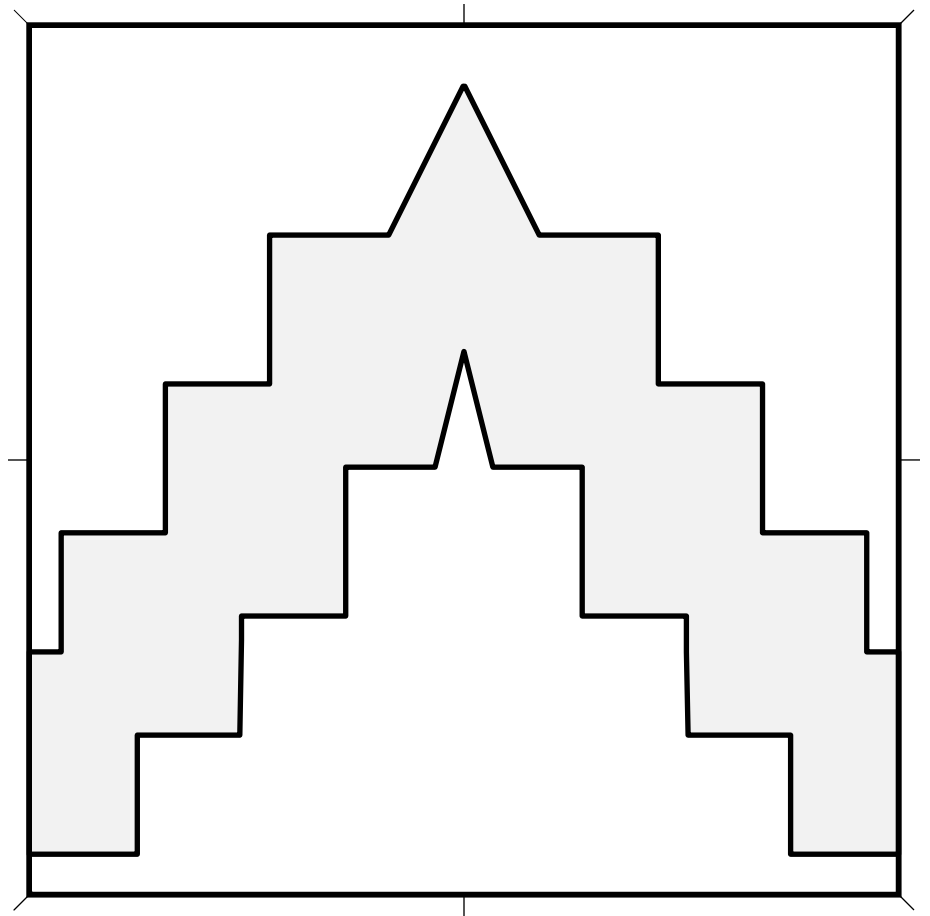

Chevron Indented 4.242

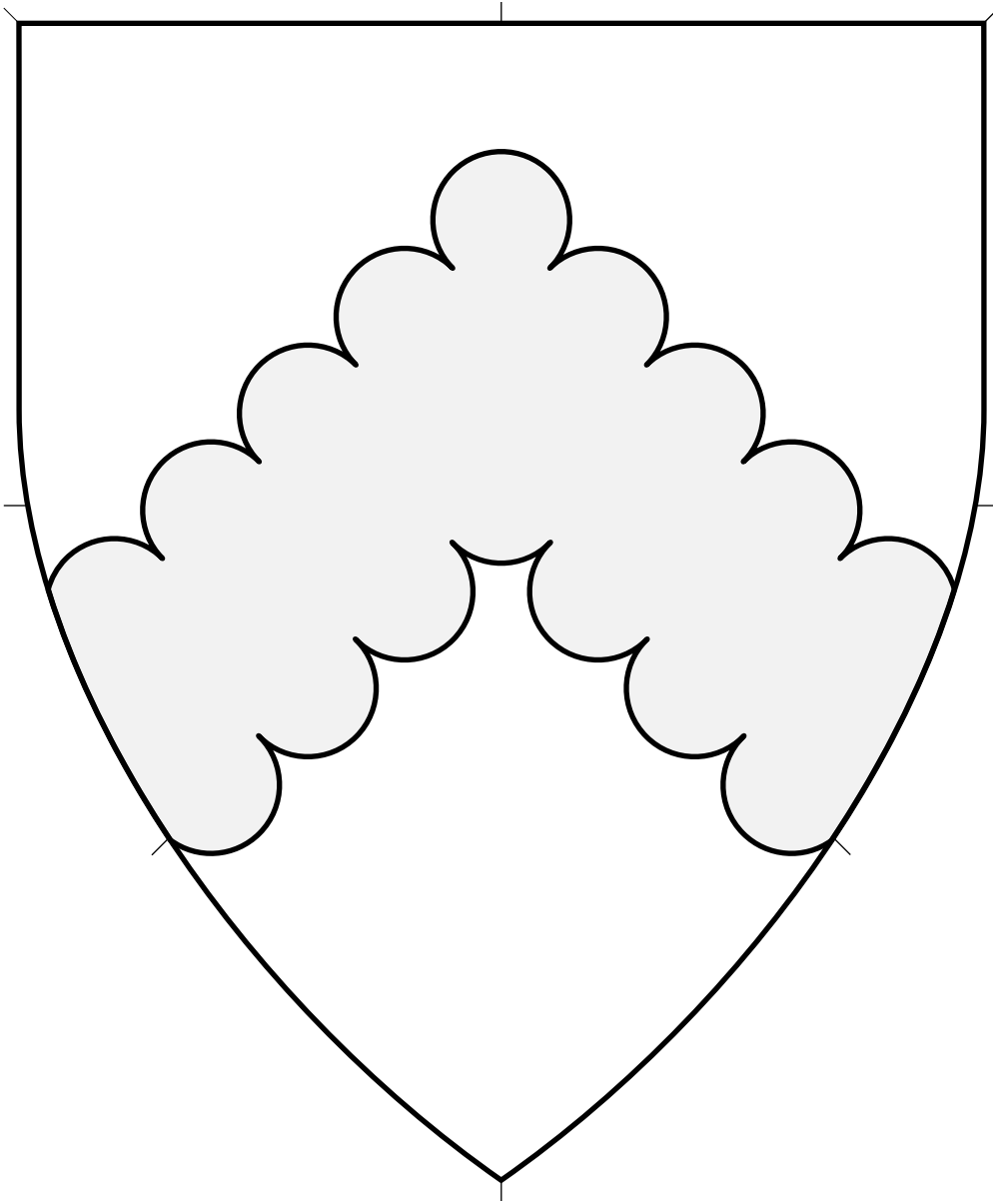

Central ordinary.

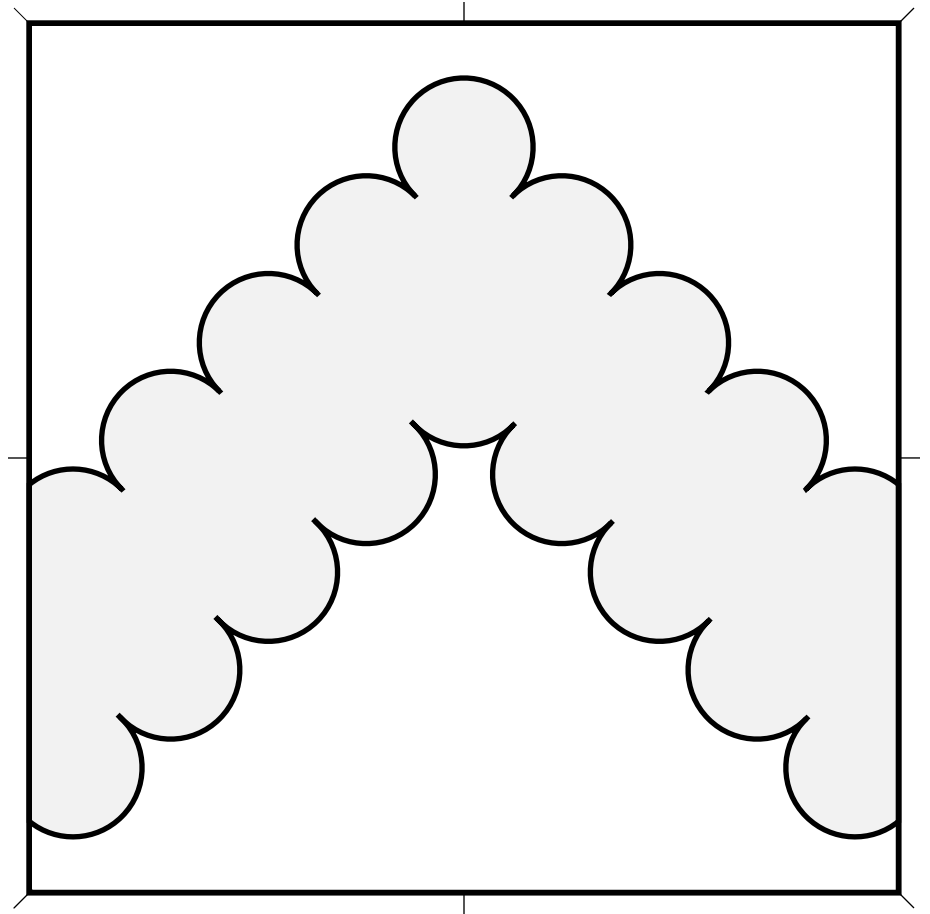

Chevron Inverted (1) 4.243

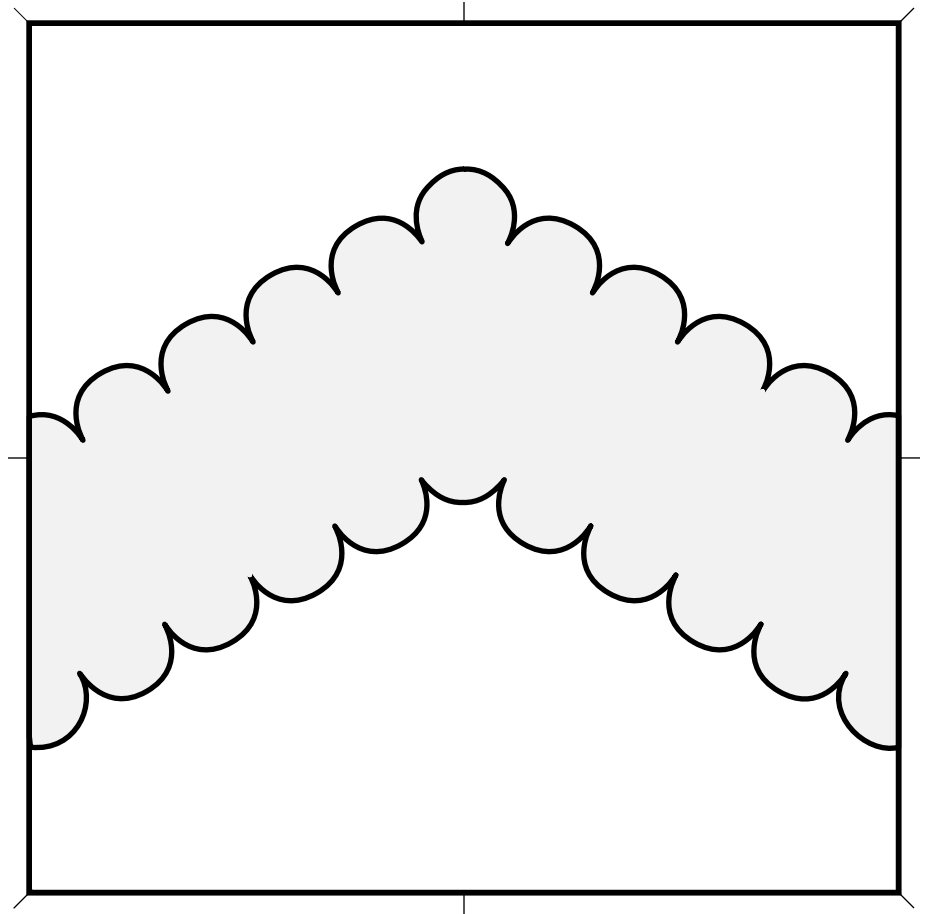
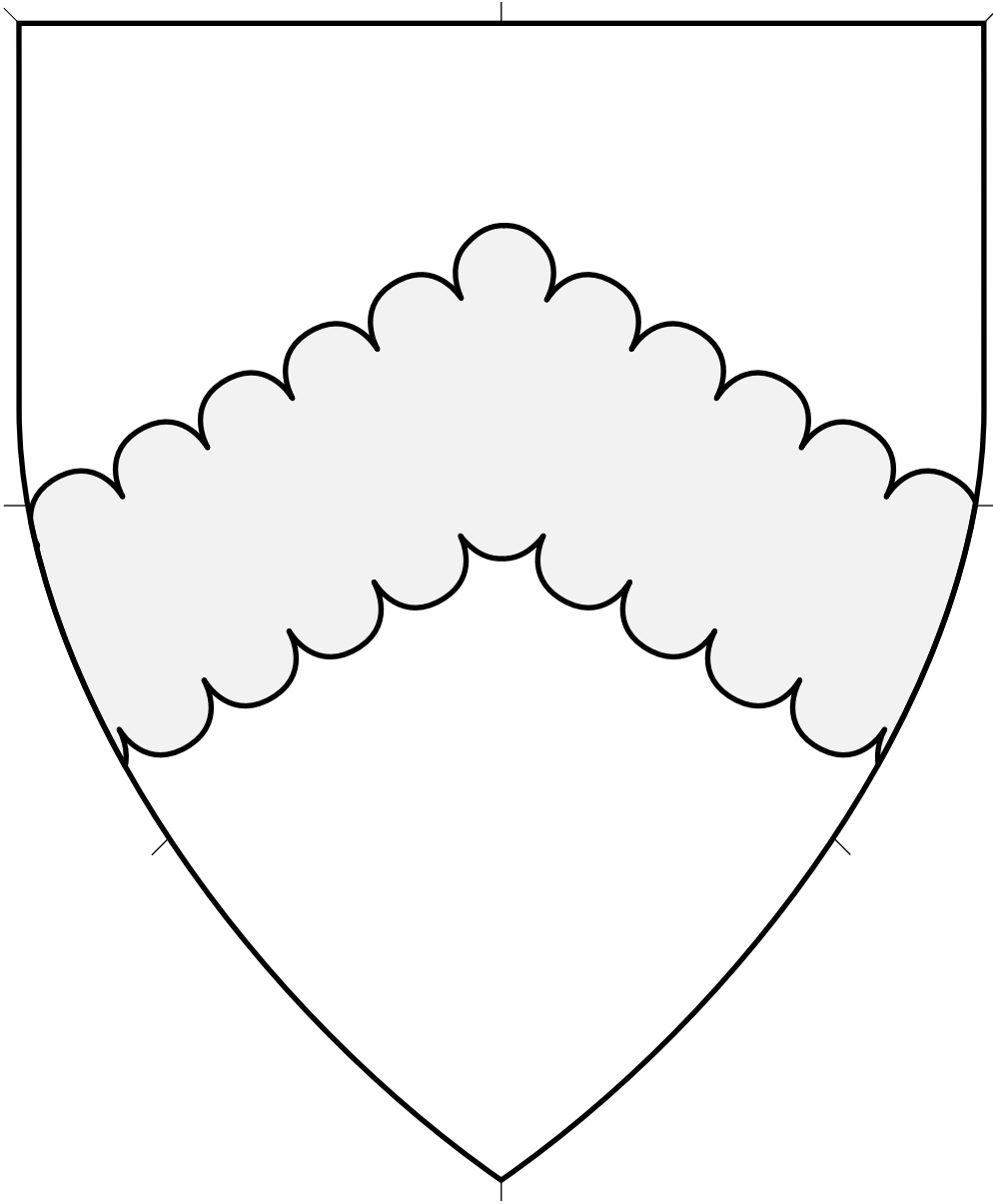

Central ordinary.

Artist: Vémundr Syvursson.

Adapted by Mathghamhain Ua Ruadháin.

Chevron Inverted (2) 4.244

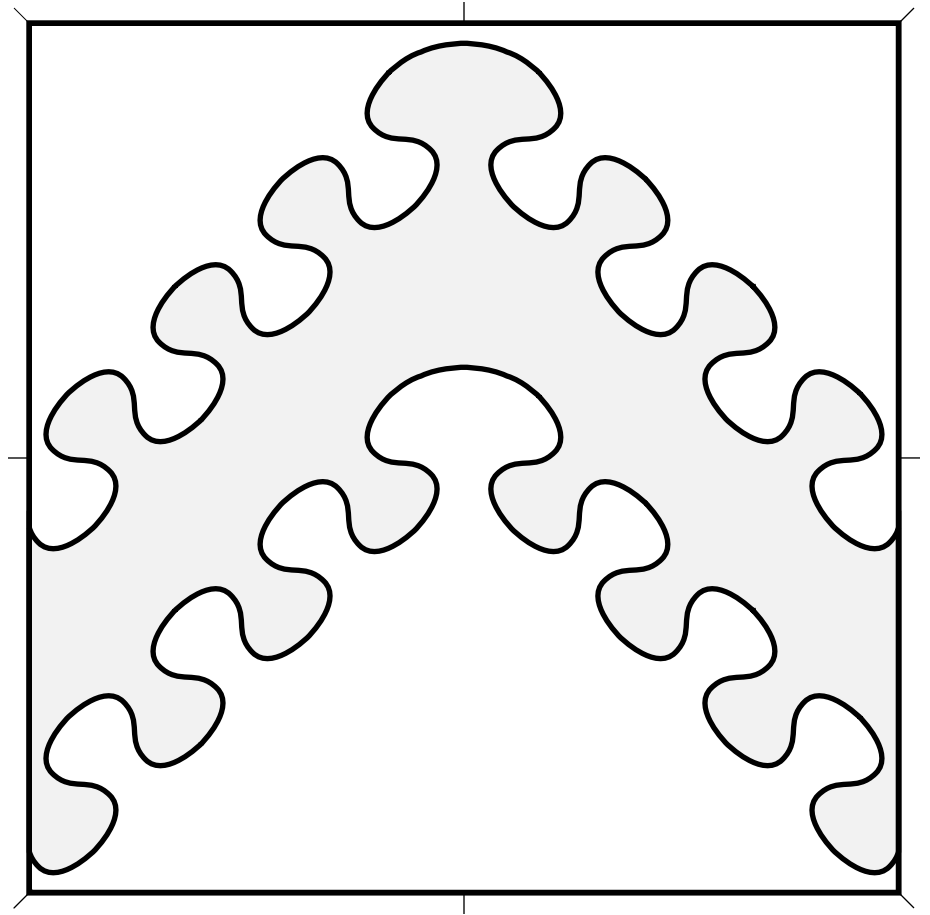
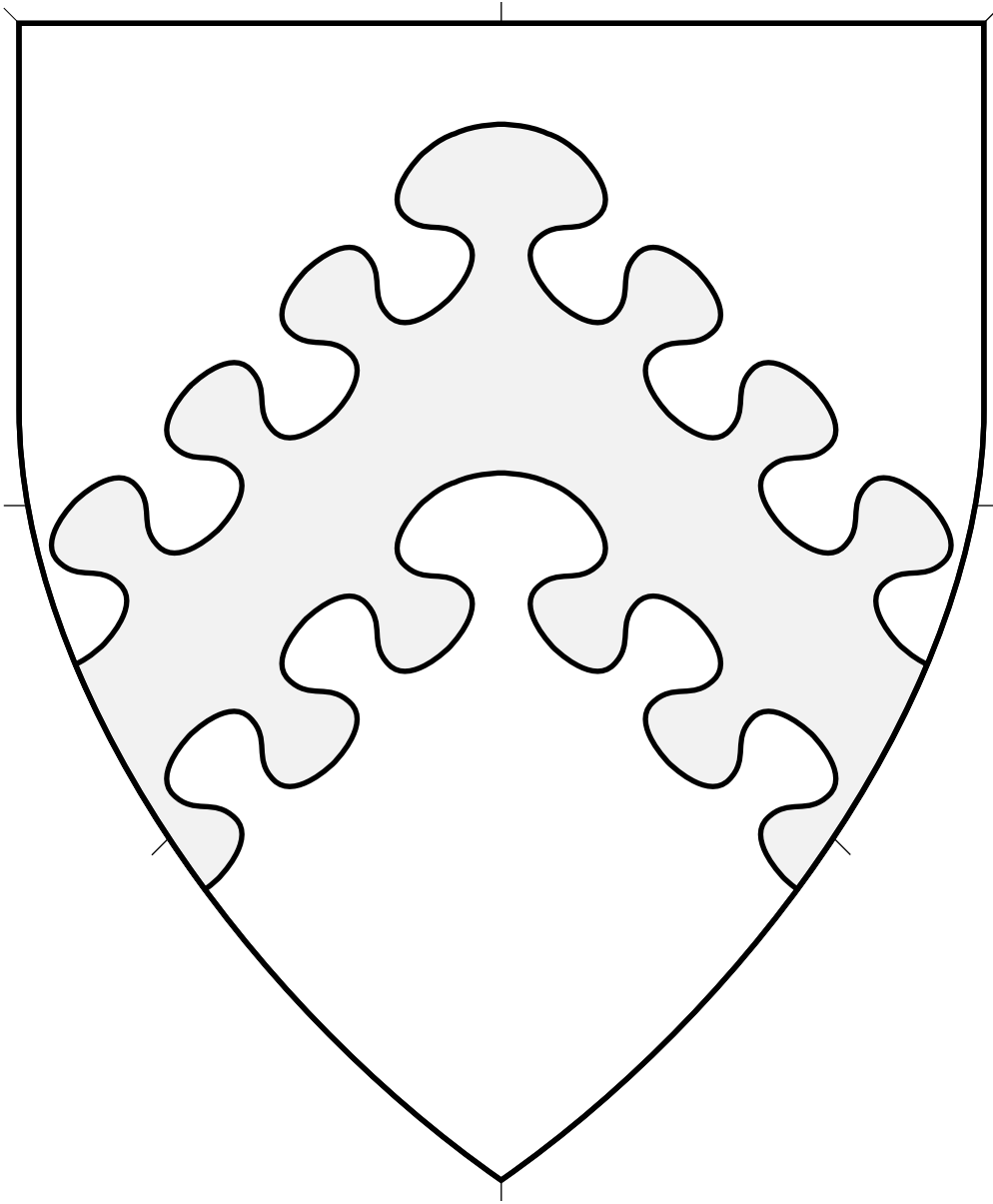

Central ordinary.

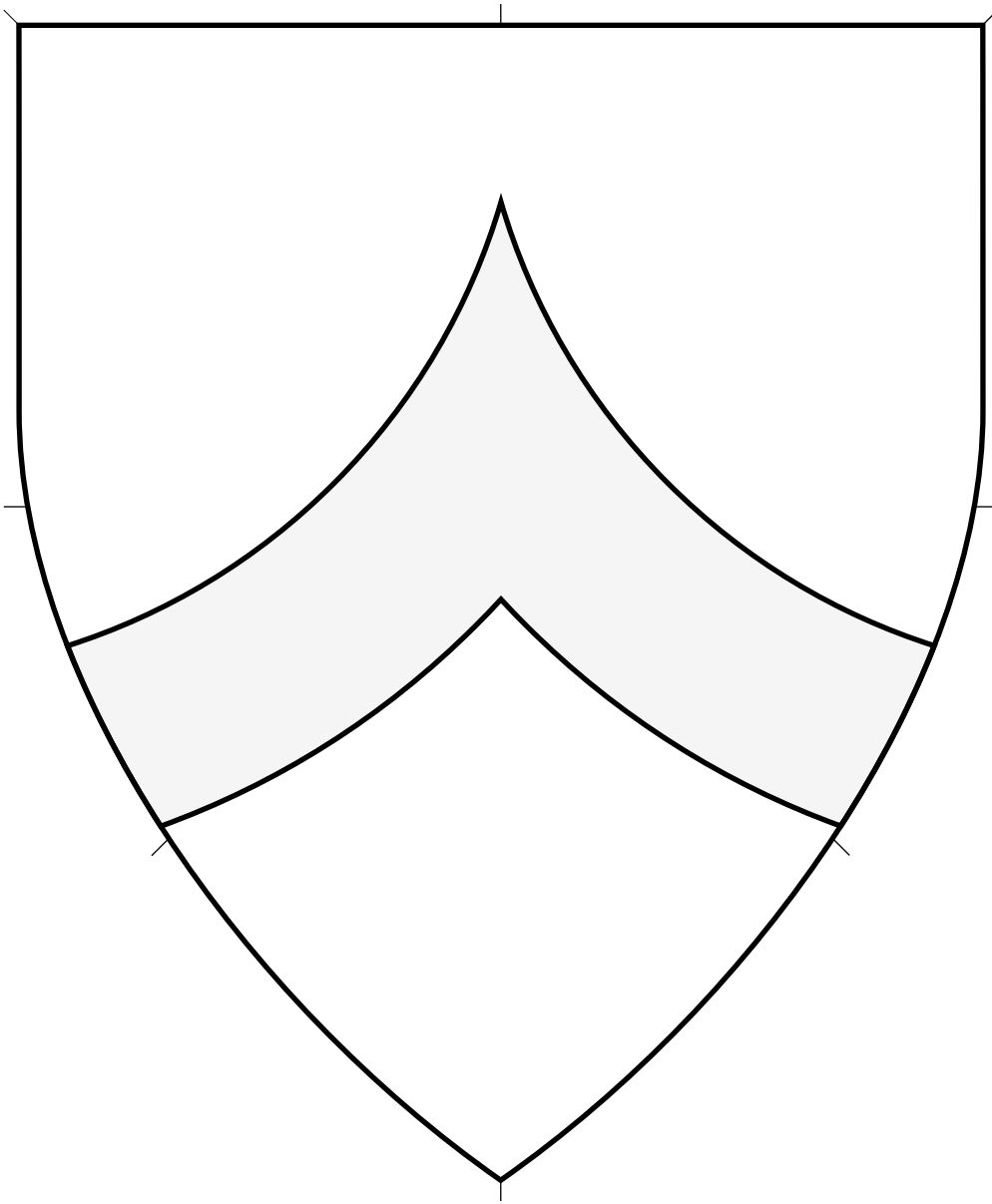

Central ordinary.

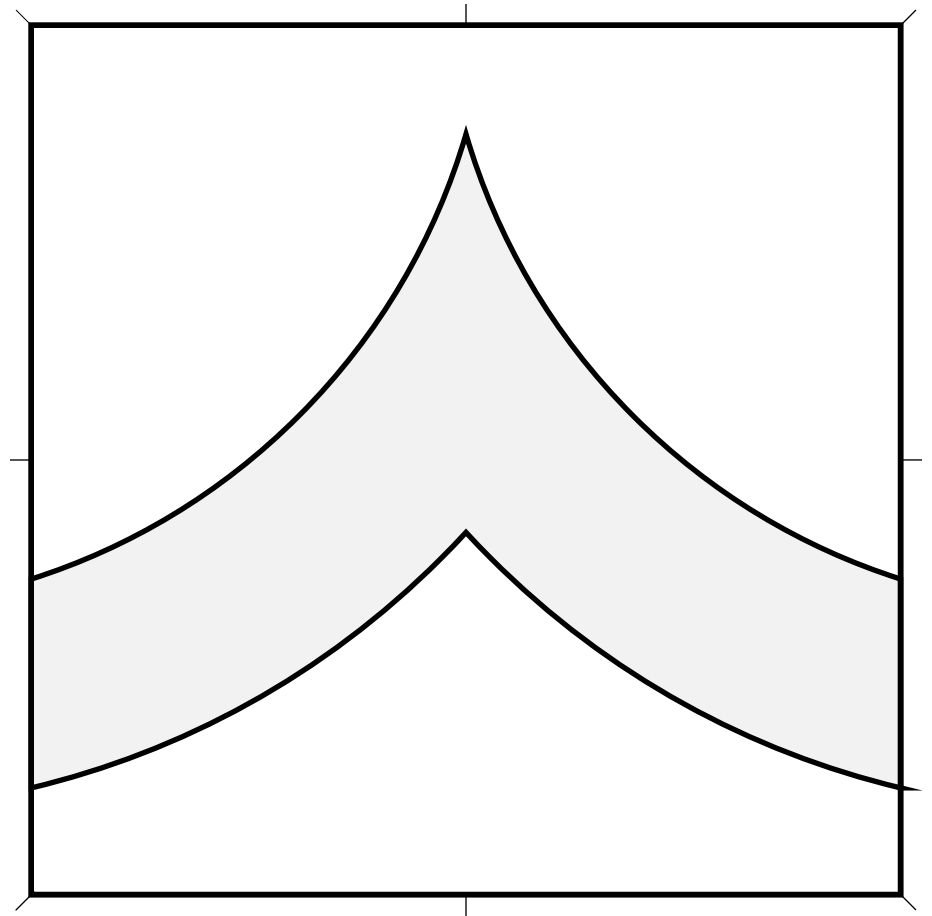

Chevron Ployé • 4.246

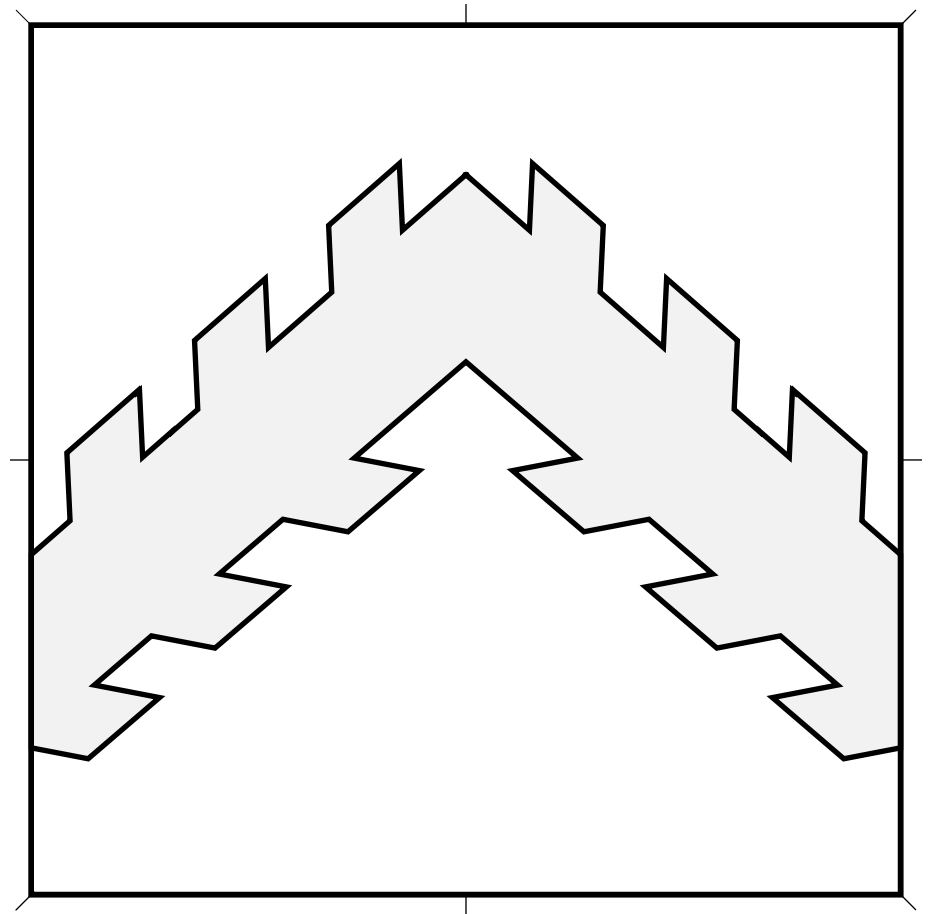
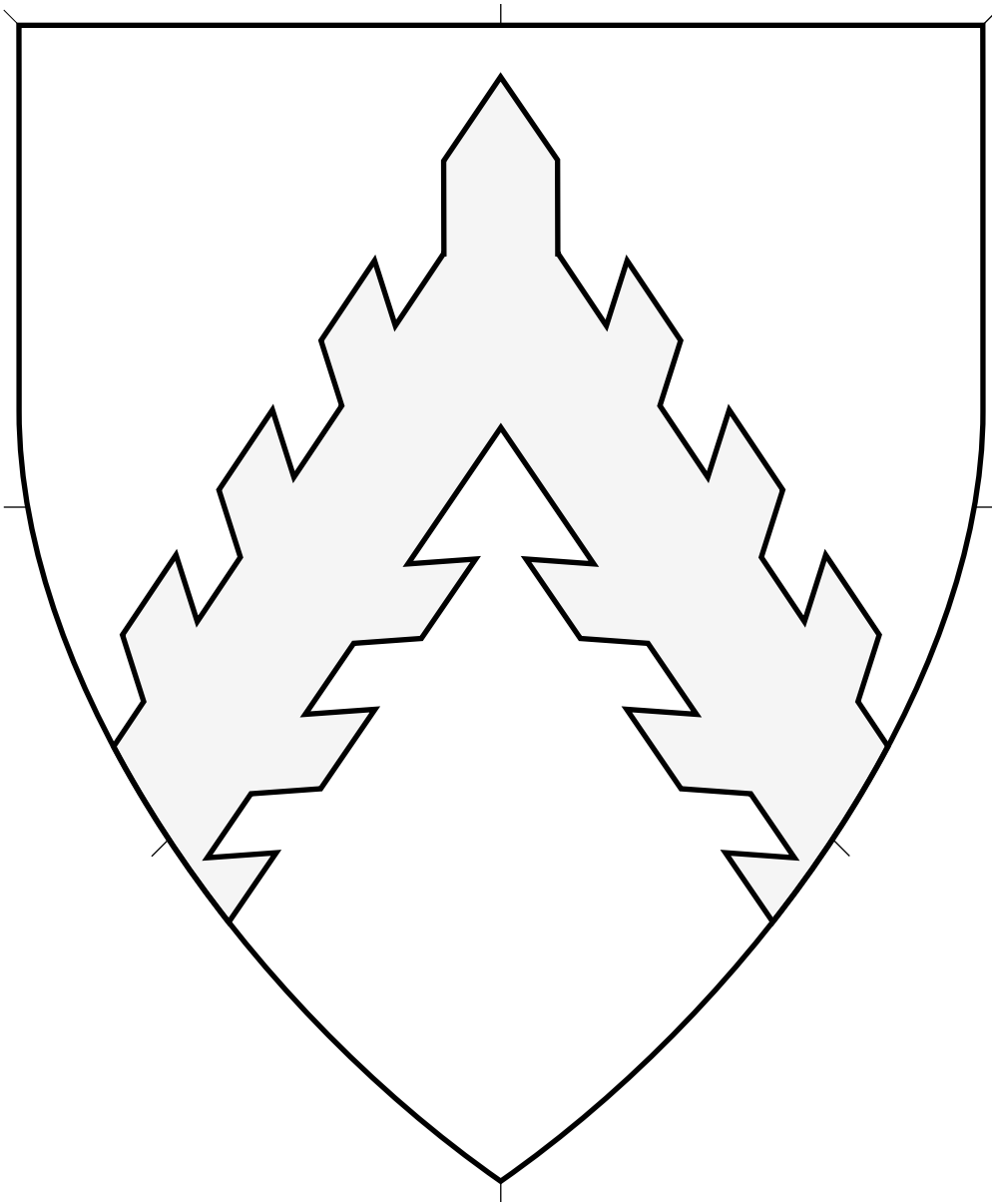

Central ordinary.

Source: Viking Answer Lady SVG Images For Heraldry. Artist: Gunnvör silfrhárr.
Adapted by Mathghamhain Ua Ruadháin.

Chevron Raguly 4.247

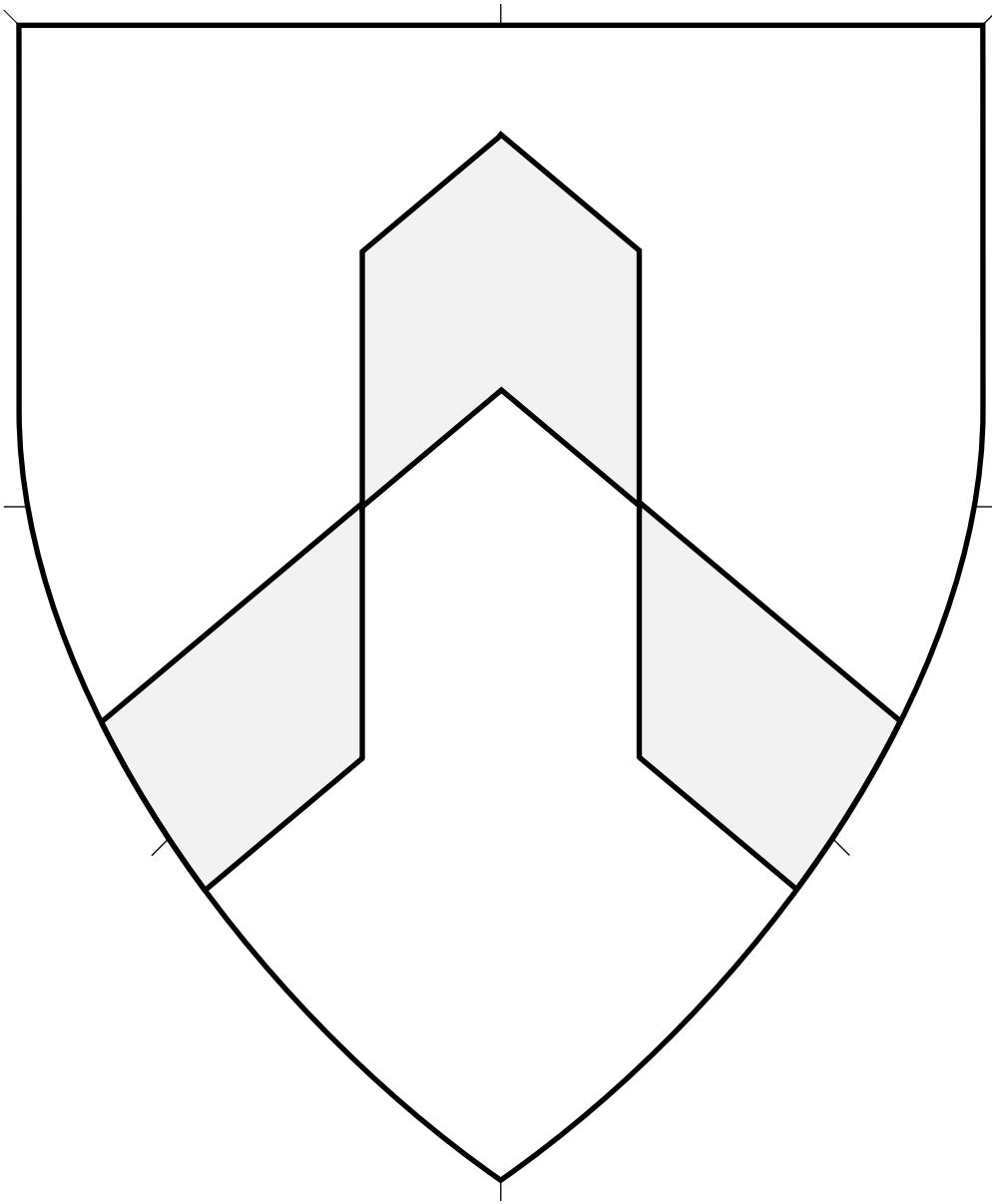

Central ordinary.

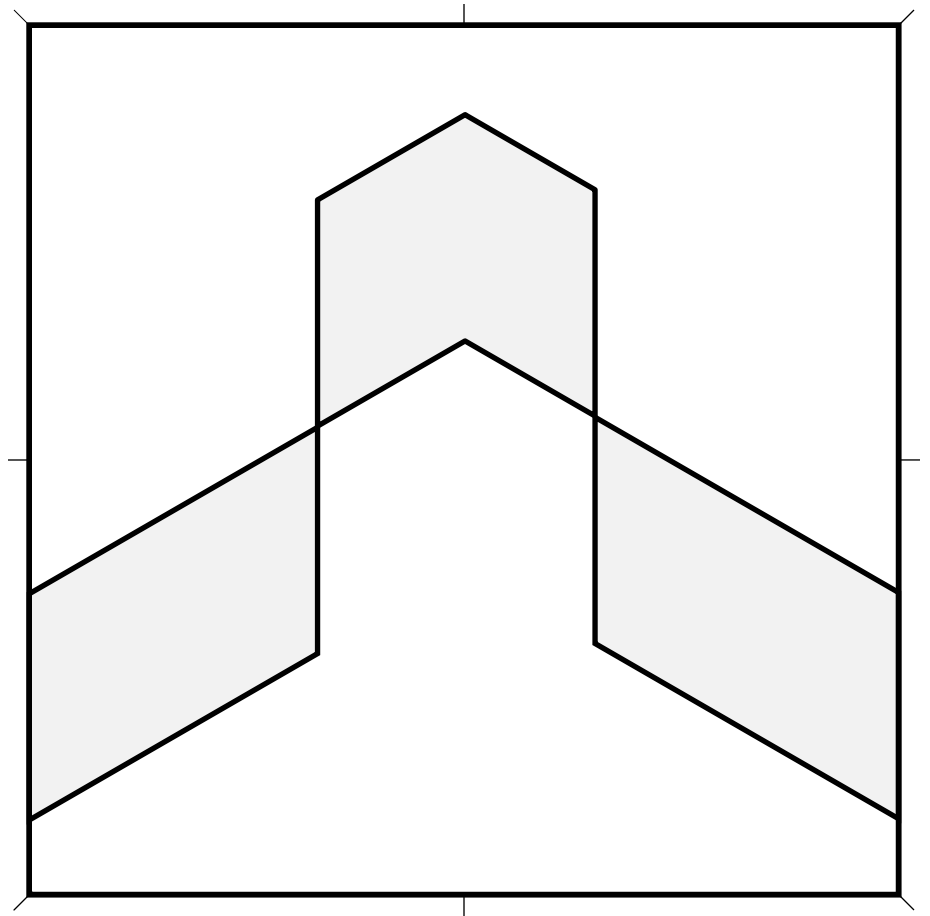

Chevron Rompu (1) 4.248

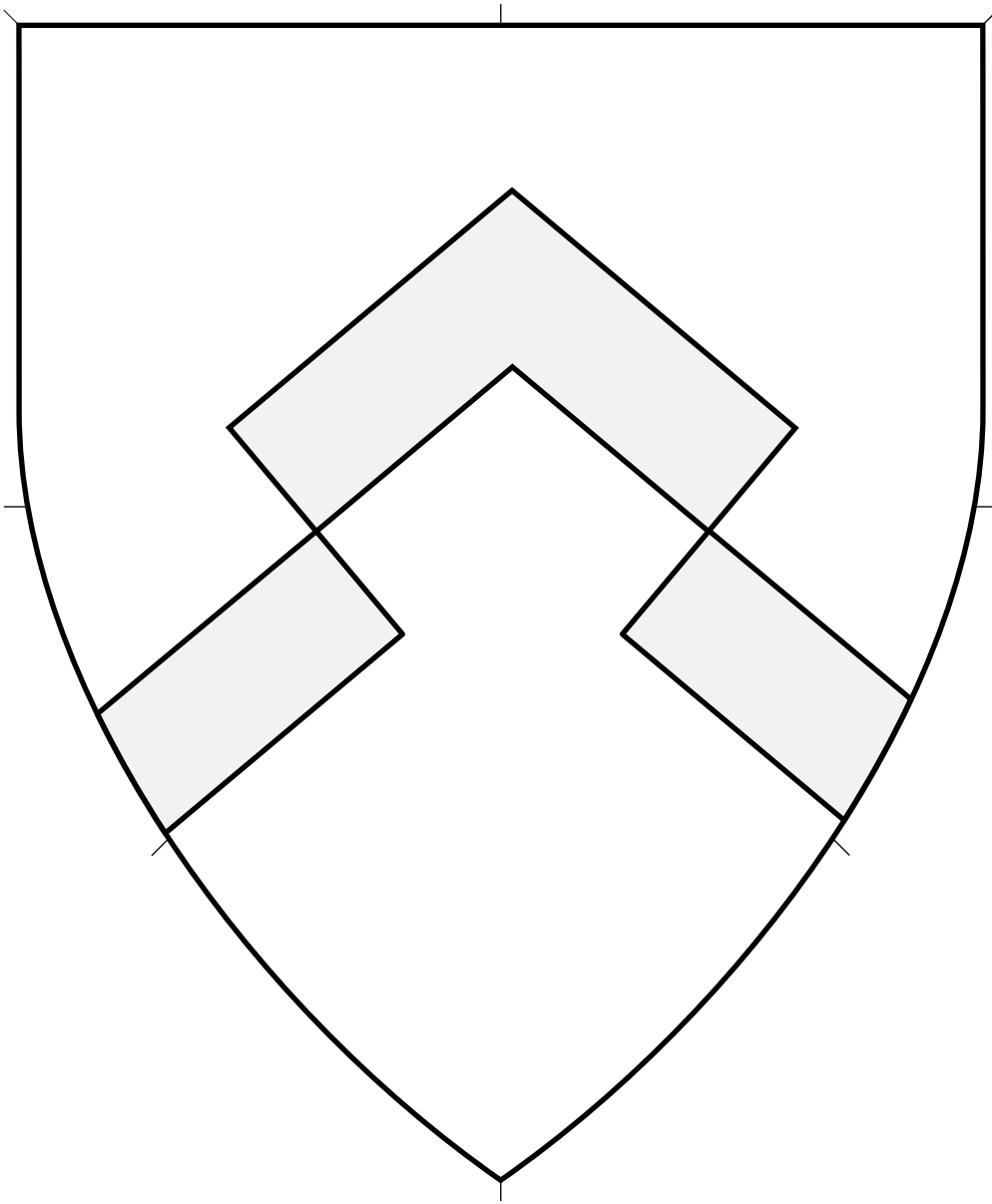

Central ordinary.

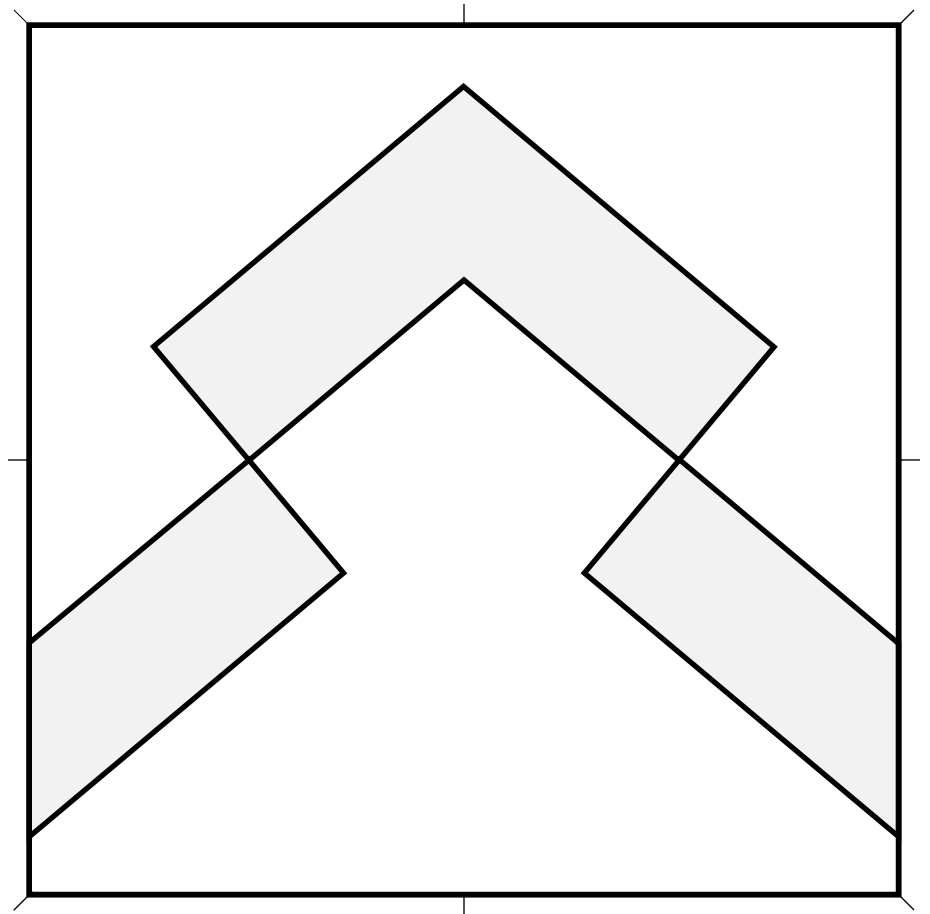

Chevron Rompu (2) • 4.249

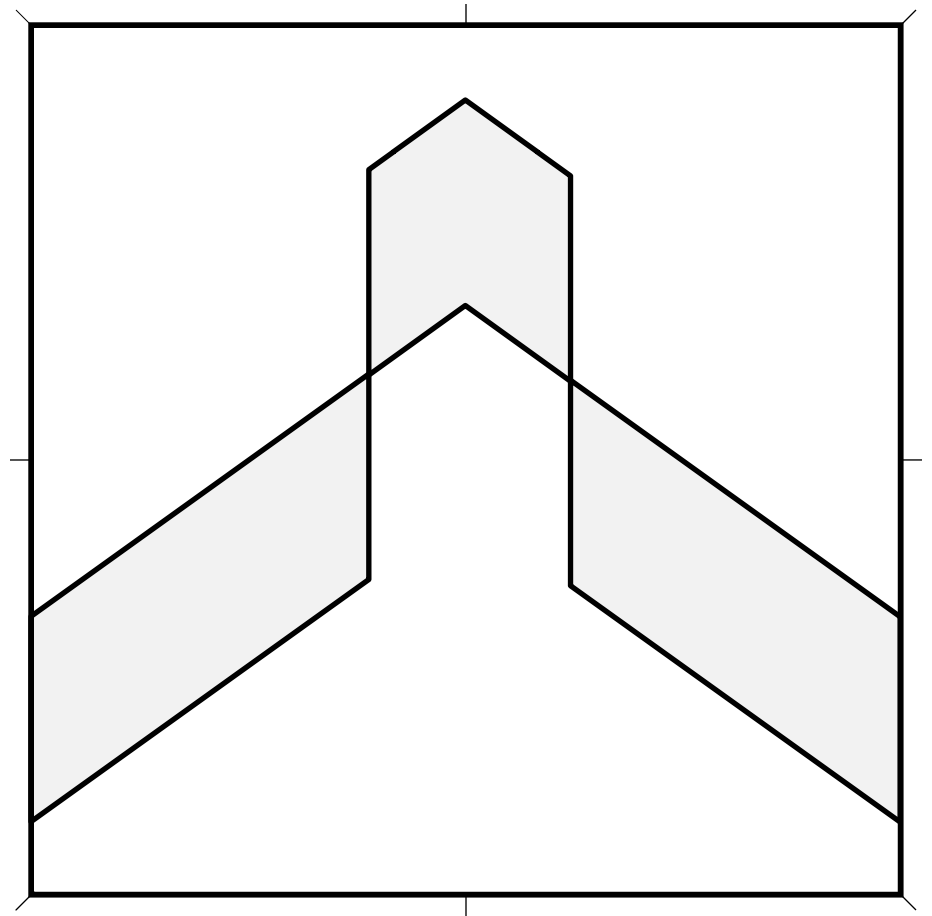
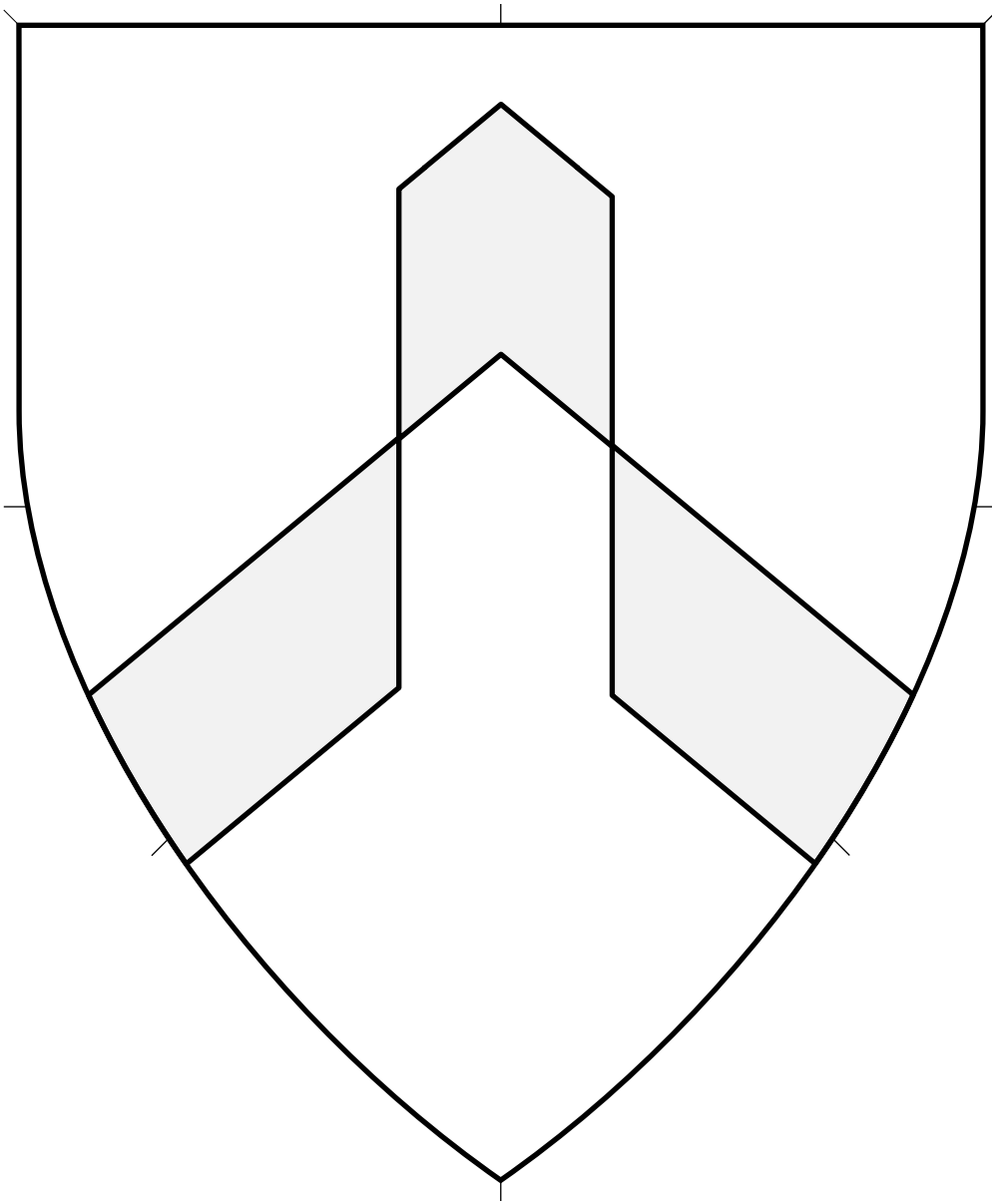

Central ordinary.

Source: Viking Answer Lady SVG Images For Heraldry.
Artist: Gunnvôr silfrahárr. Adapted by Mathghamhain Ua Ruadháin.

Chevron Rompu (3) 4.250

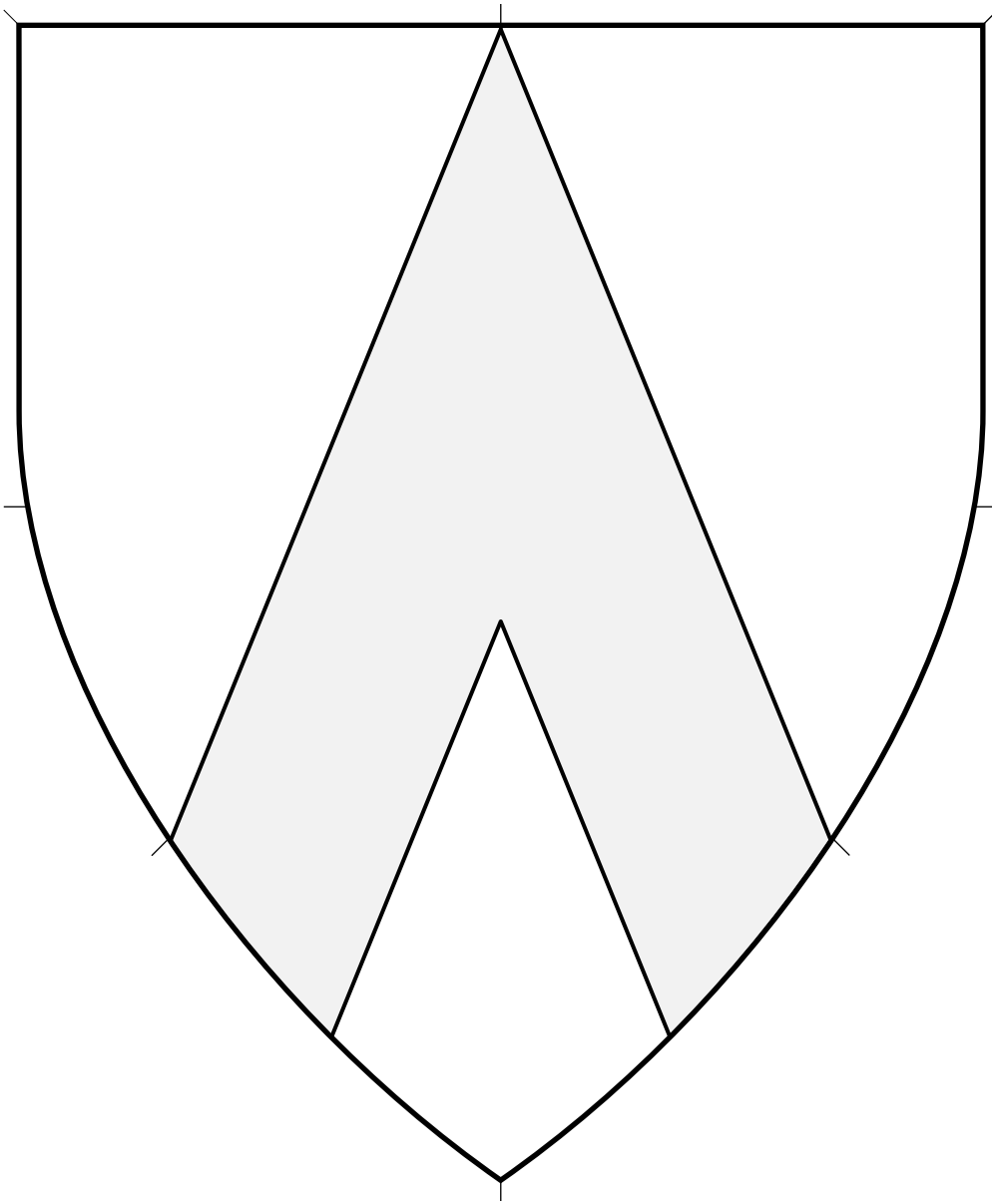

Central ordinary.

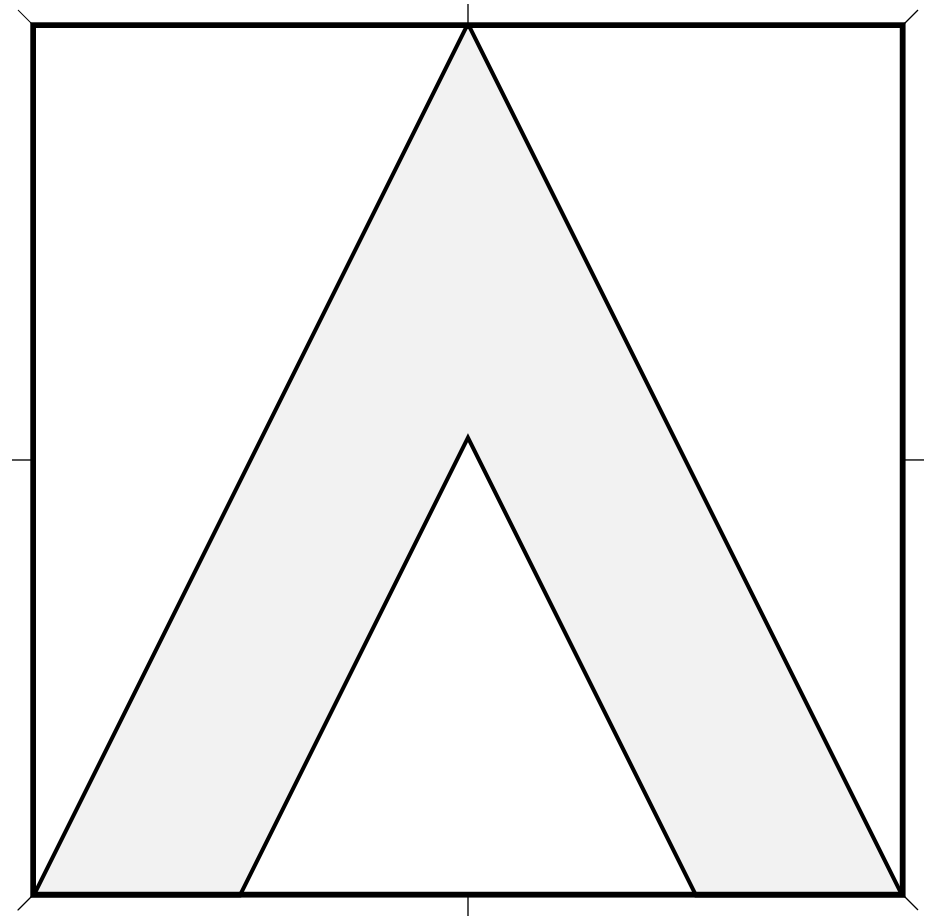

Chevron Throughout (1) • 4.251

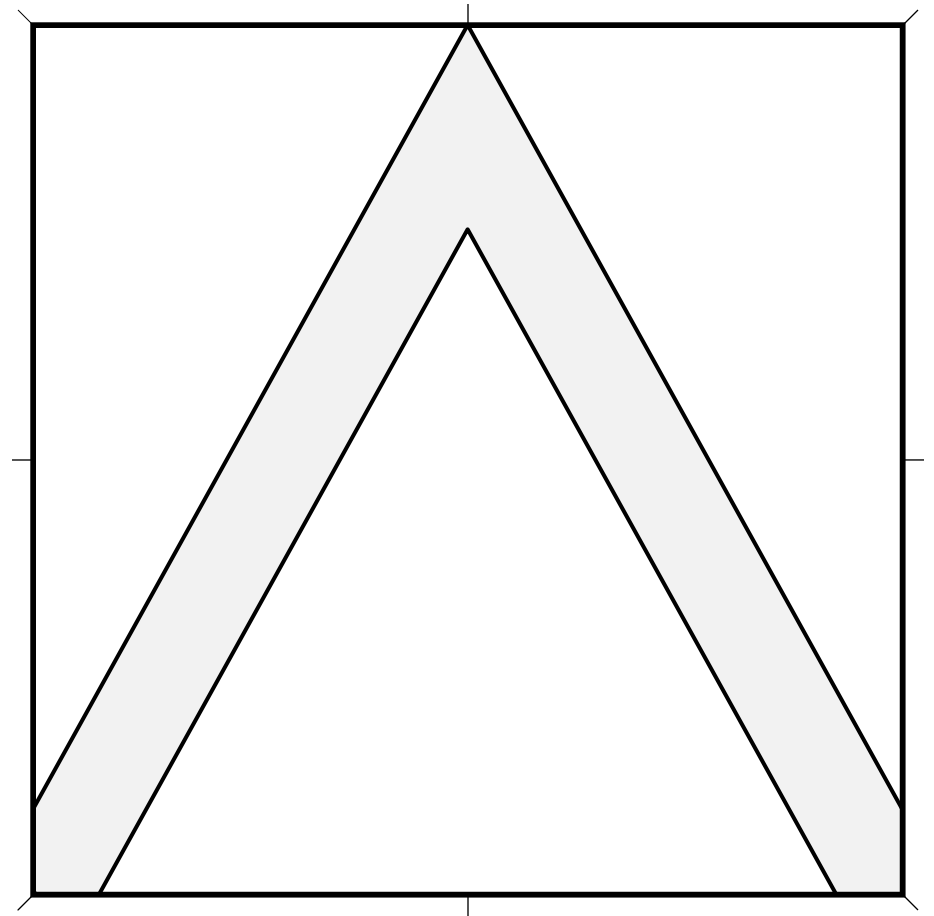
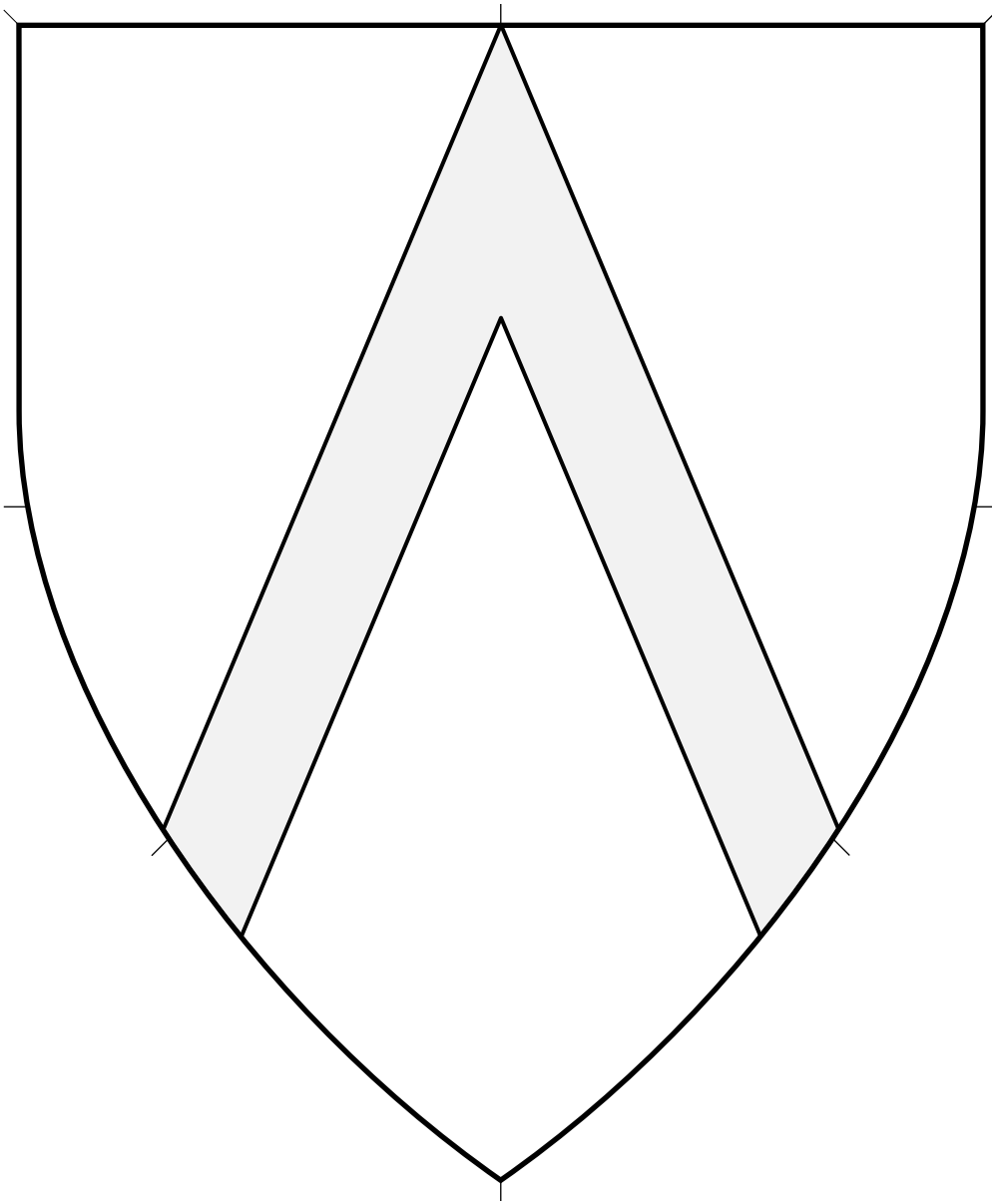

Central ordinary.

Source: Armorial Lorrain de la Première Moitié du XVIe Siècle.
(Page 44.) Artist unknown.

Chevron Throughout (2) 4.252

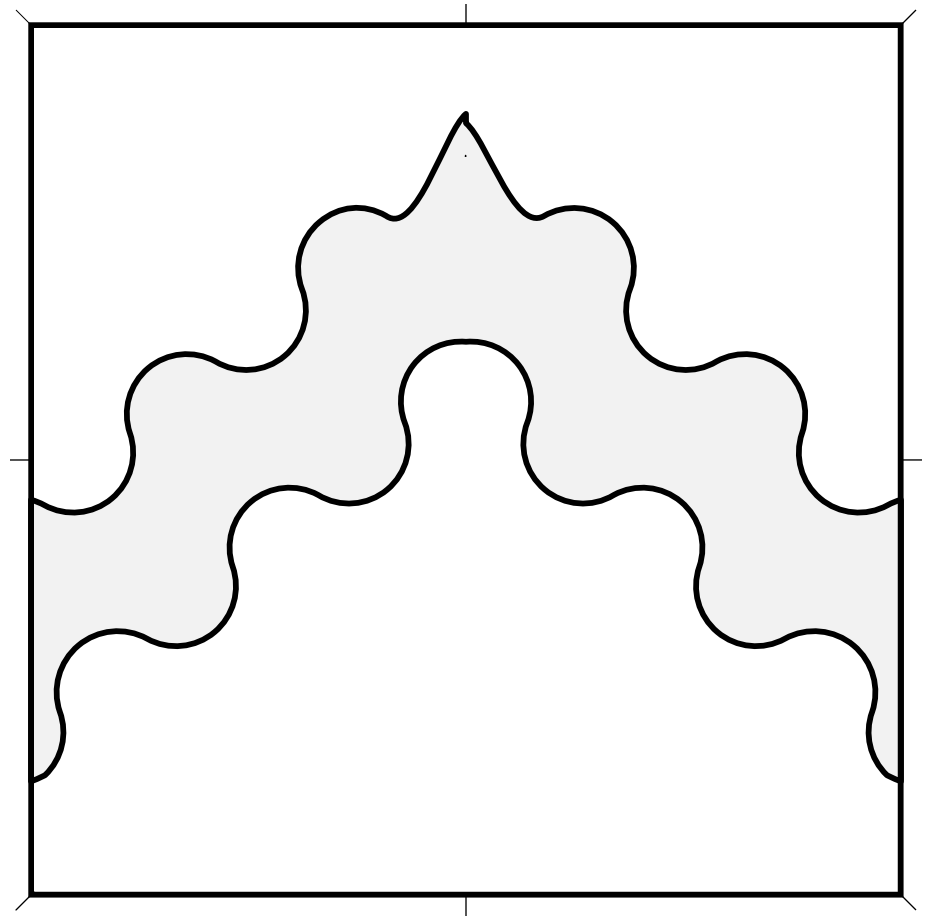
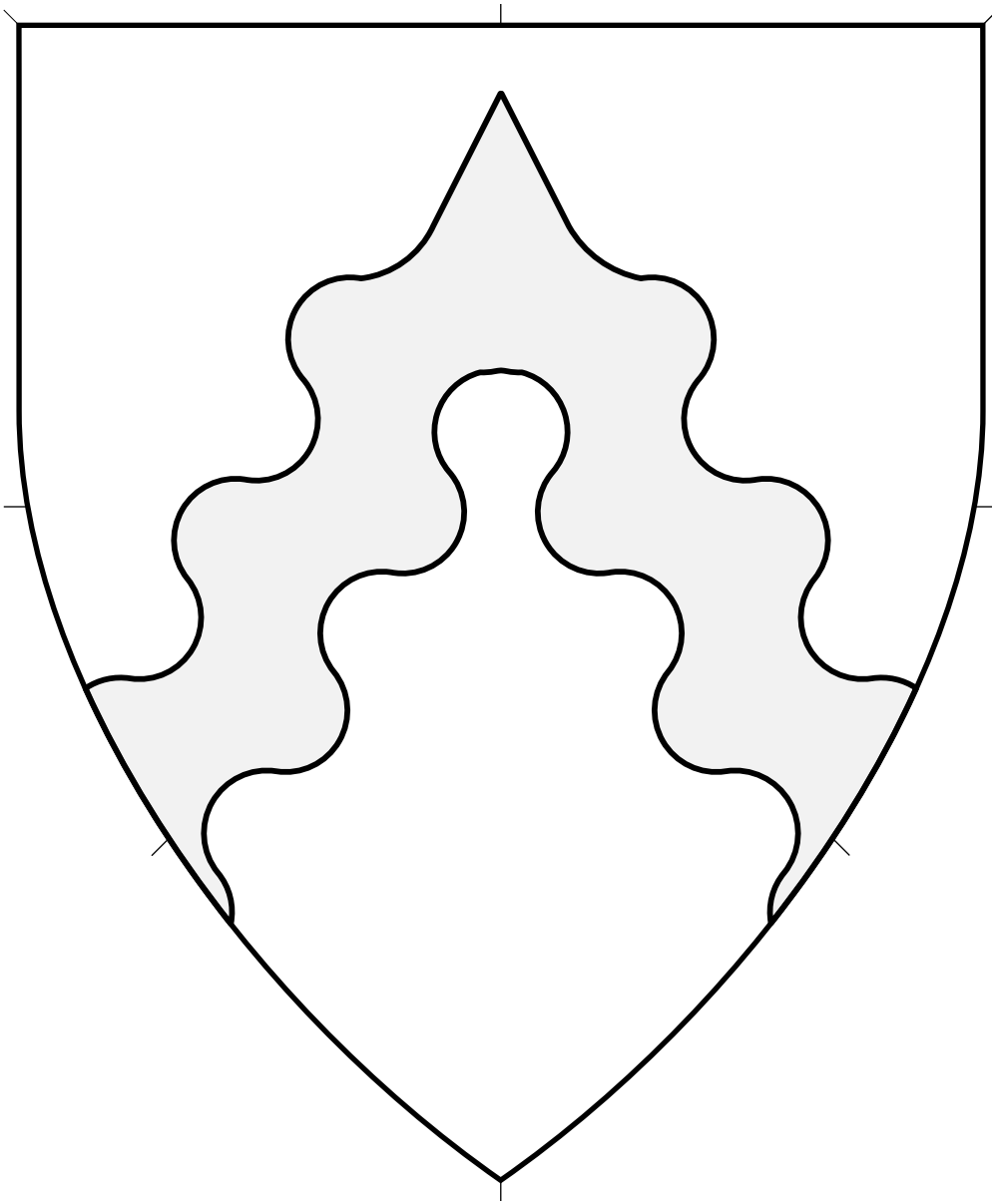

Central ordinary.

Source: Viking Answer Lady SVG Images For Heraldry.
Artist: Gunnvôr silfrhárr. Adapted by Mathghamhain Ua Ruadháin.

Chevron Wavy 4.253

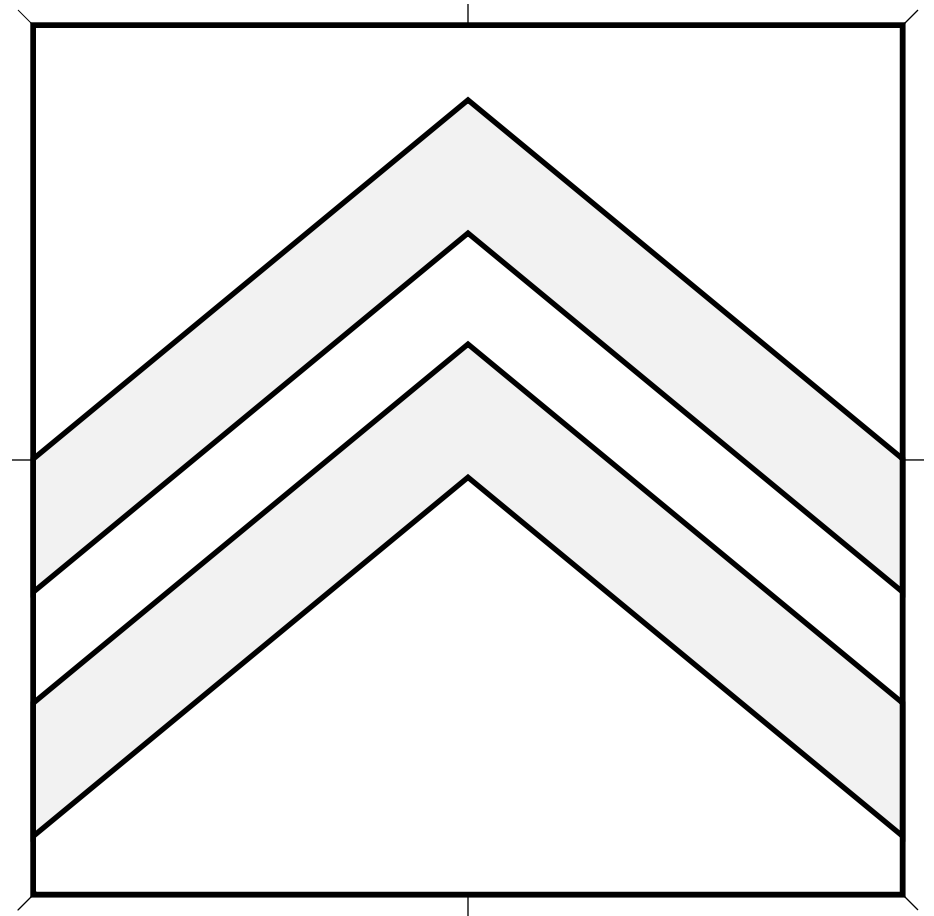
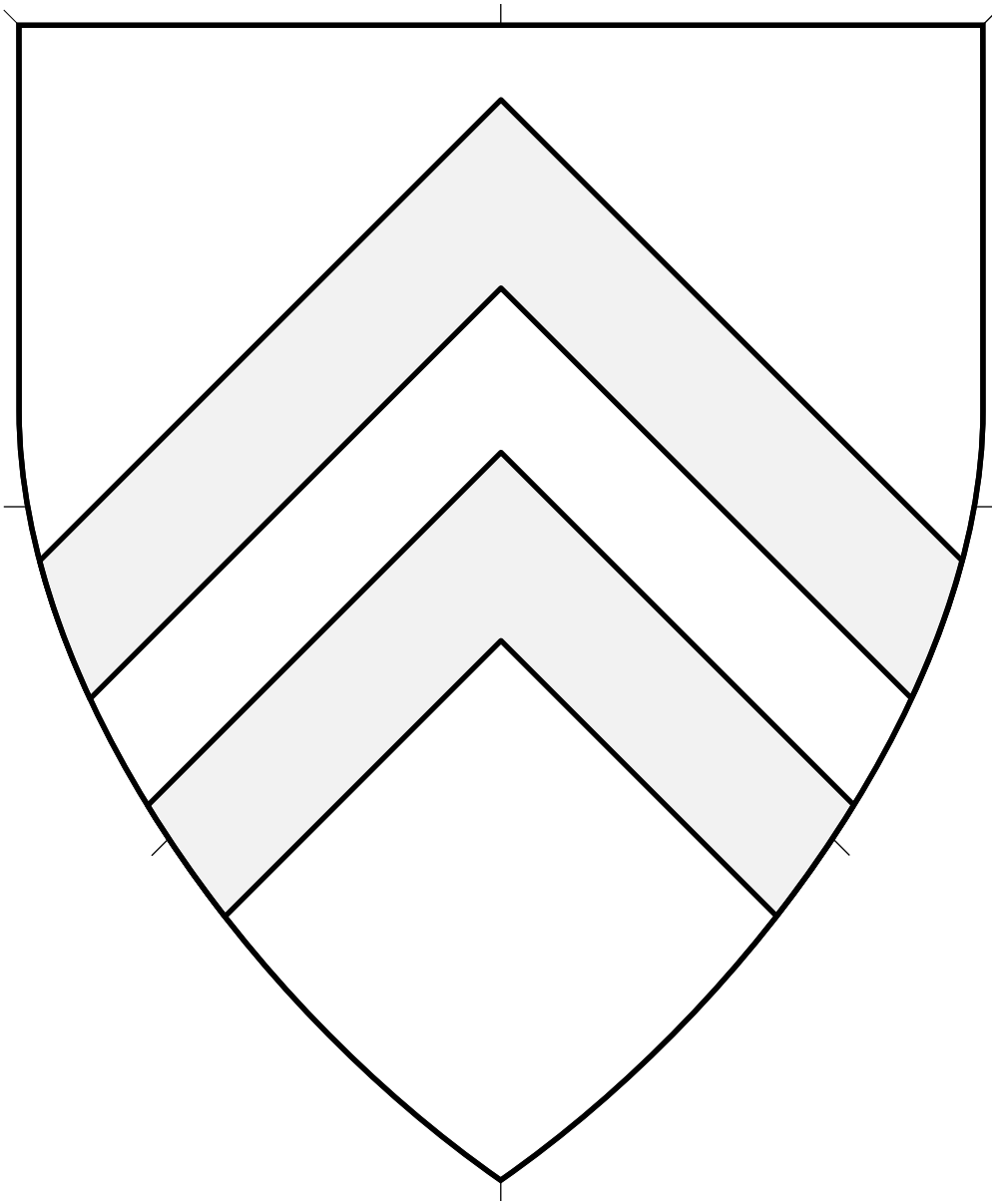

Central ordinary.

Chevronels, 2 (1) 4.254

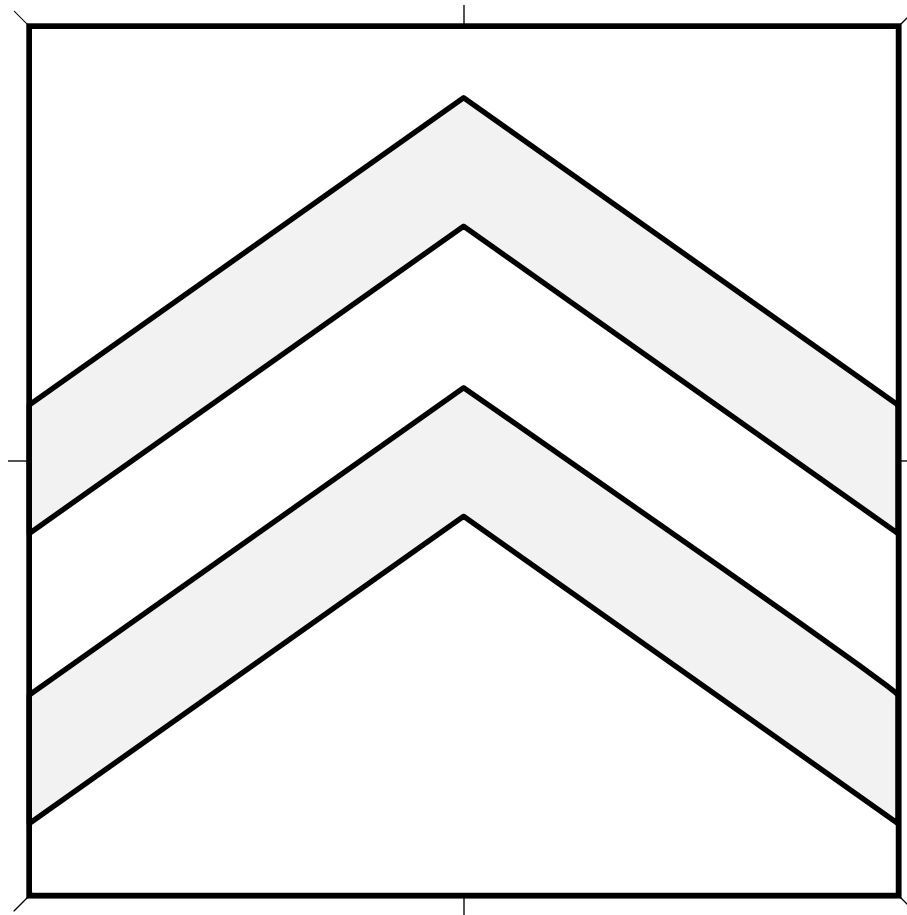
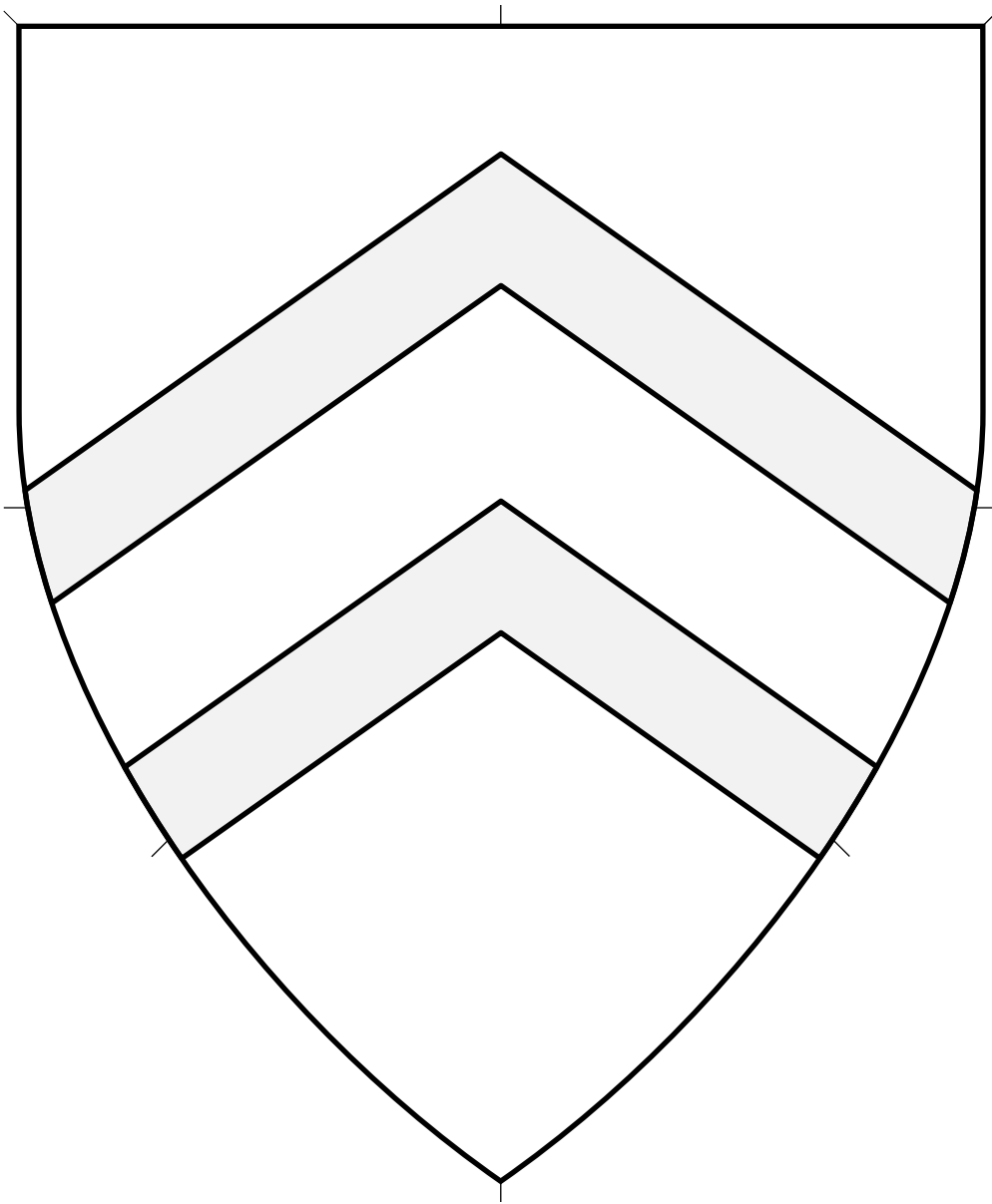

Central ordinary.

Source: English Arms A. Artist unknown. (Page 89.)

Chevronels, 2 (2) 4.255

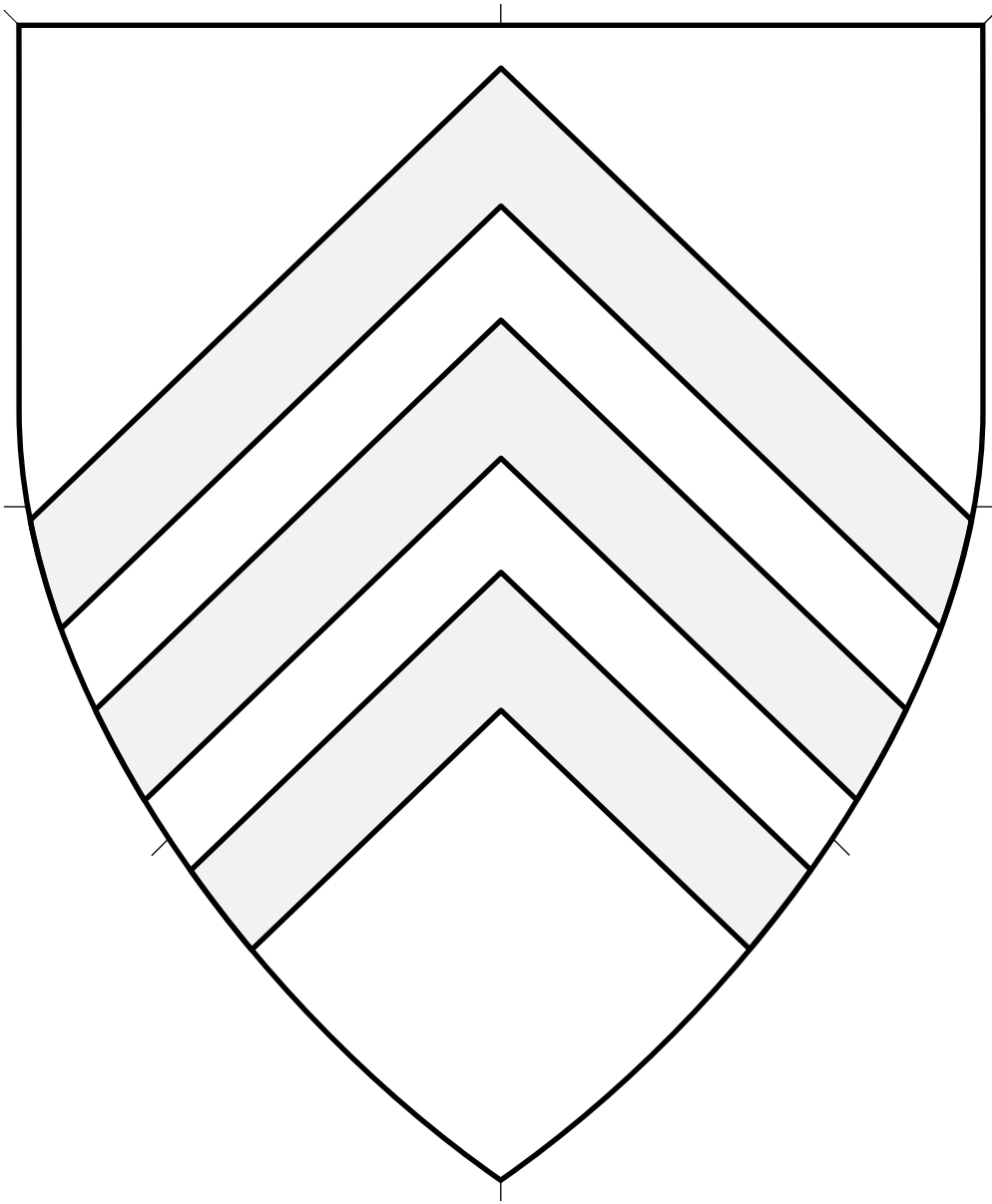

Central ordinary.

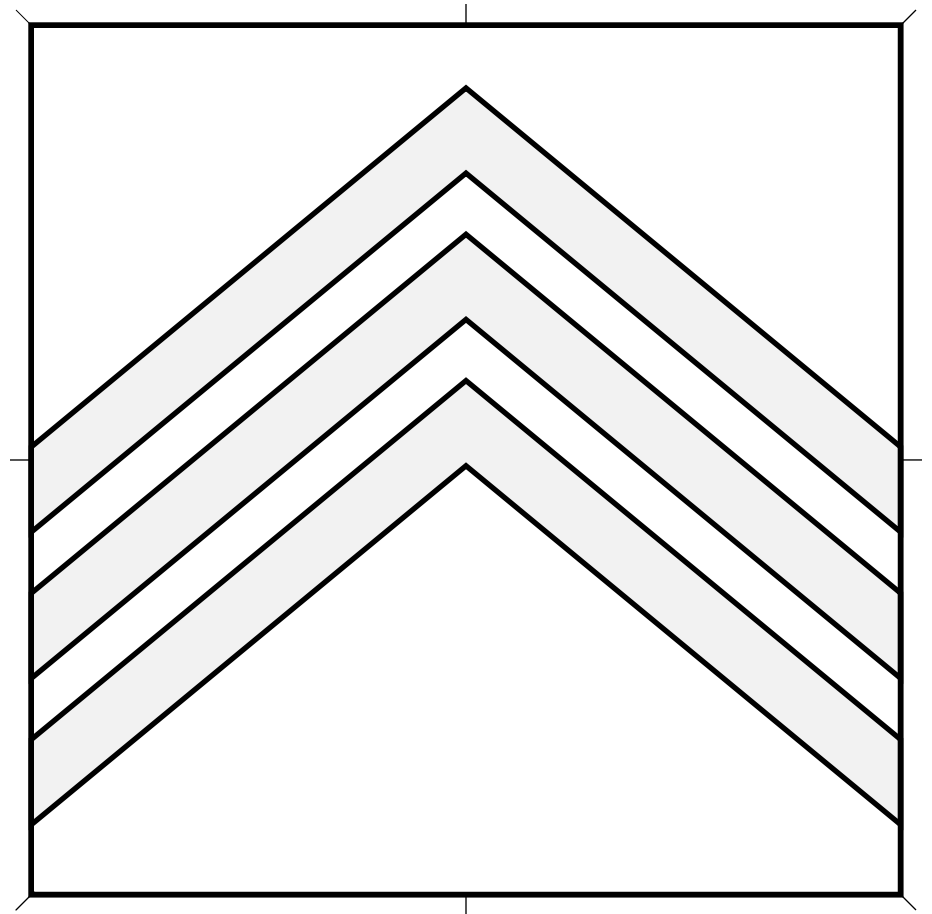

Chevronels, 3 (1) 4.256

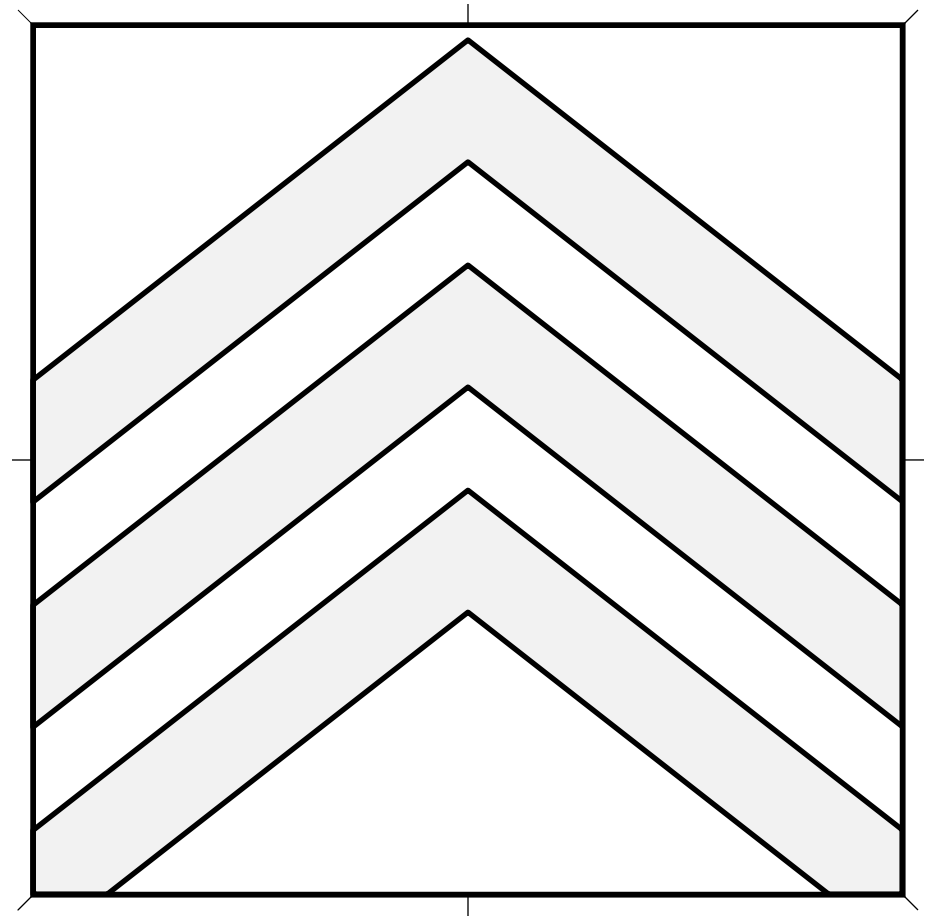
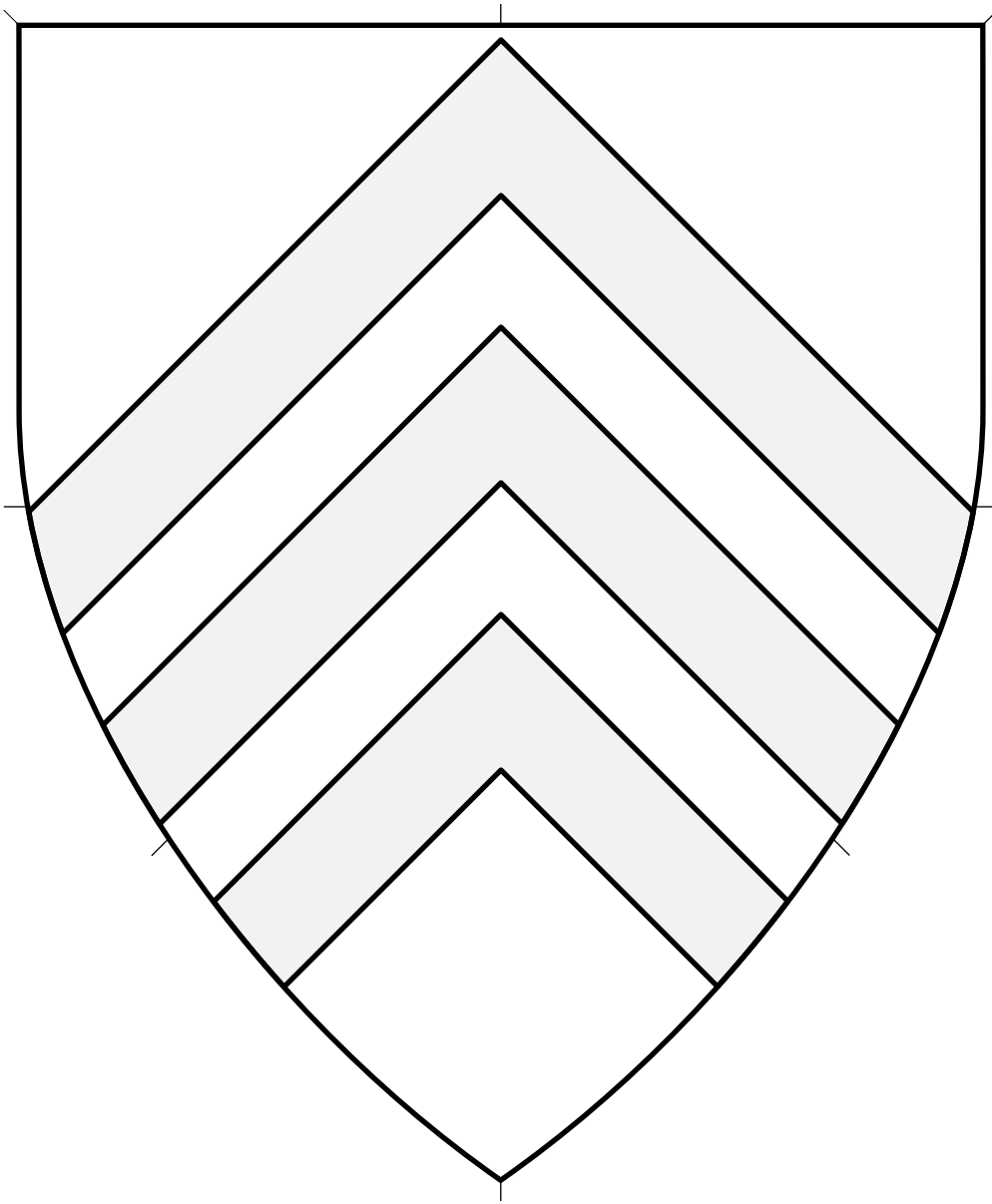

Central ordinary.

Source: Insignia Equitum Gallici Ordinis Sancti Michaelis.
Artist unknown. (Page 150.)

Chevronels, 3 (2) 4.257

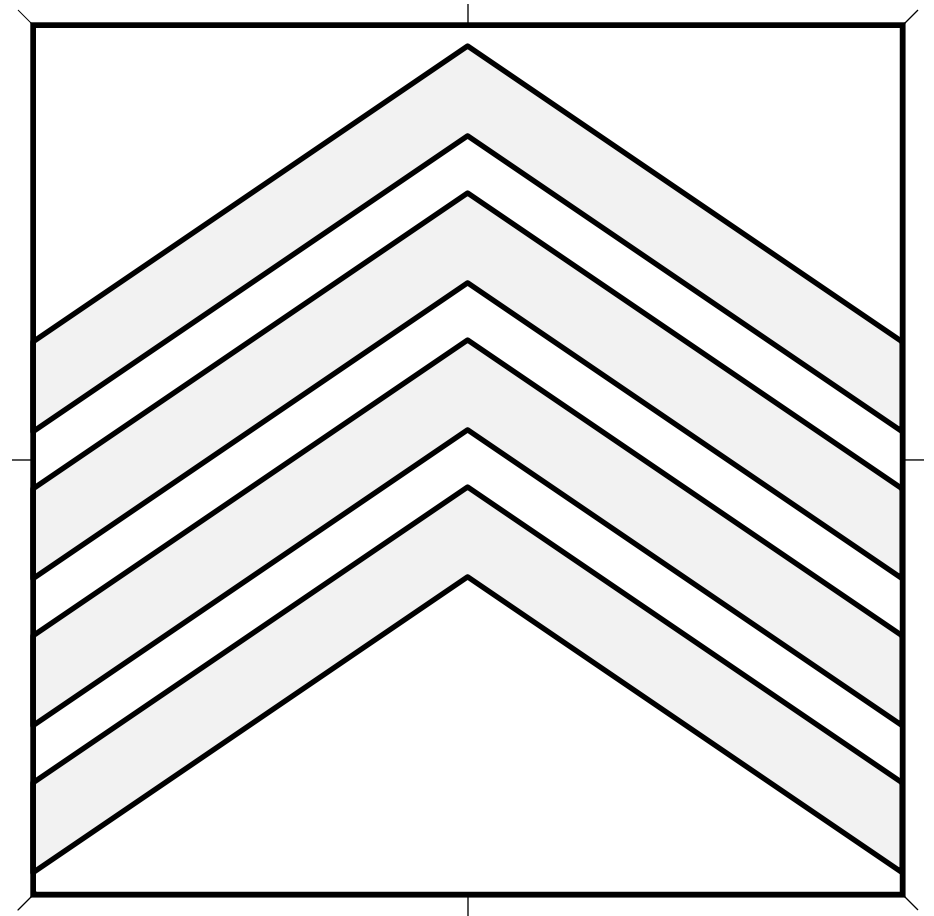
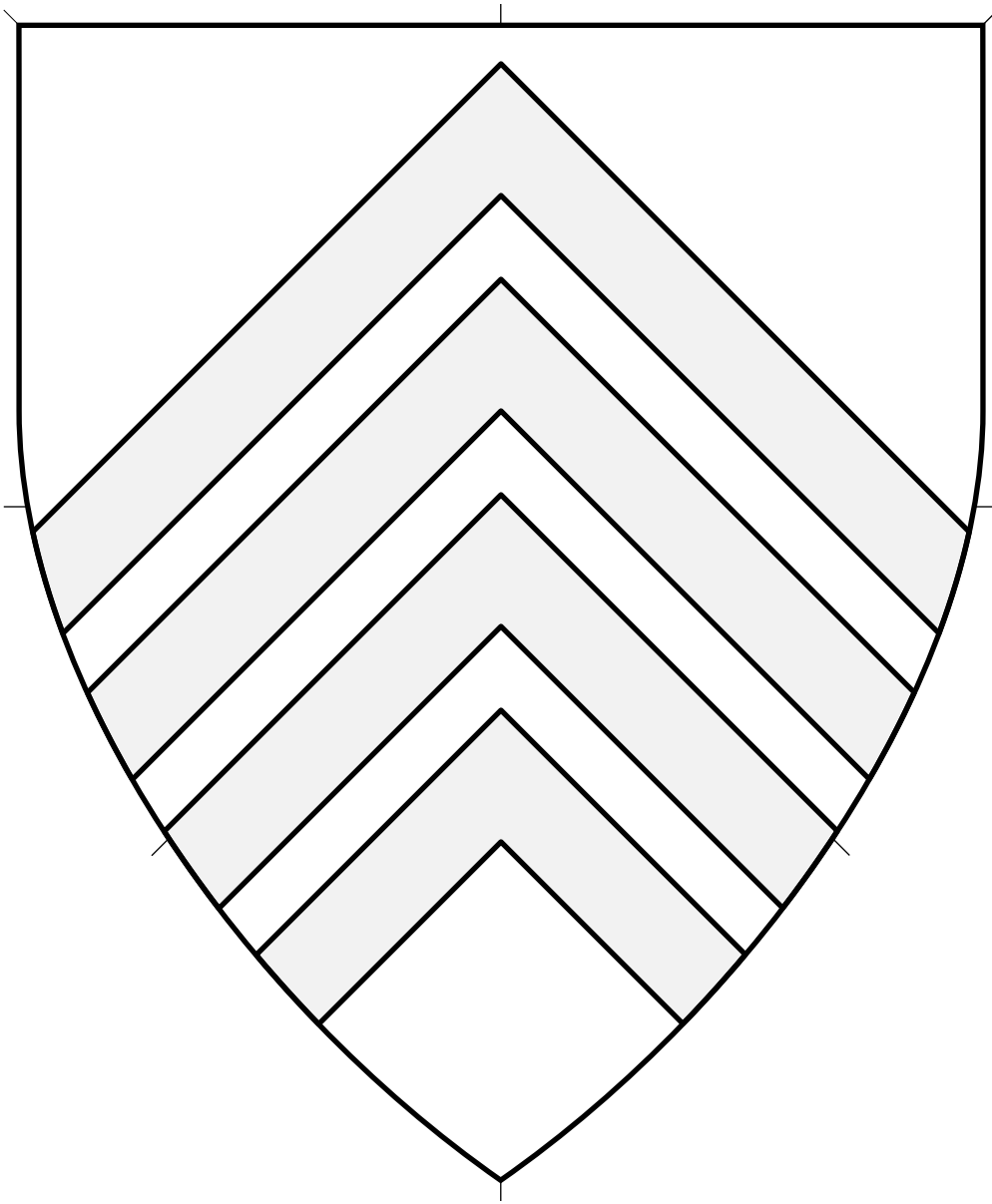

Central ordinary.

Source: Vatican MS Reg. lat. 809. Artist unknown. (Folio 32r.)

Chevronels, 4 (1) 4.258

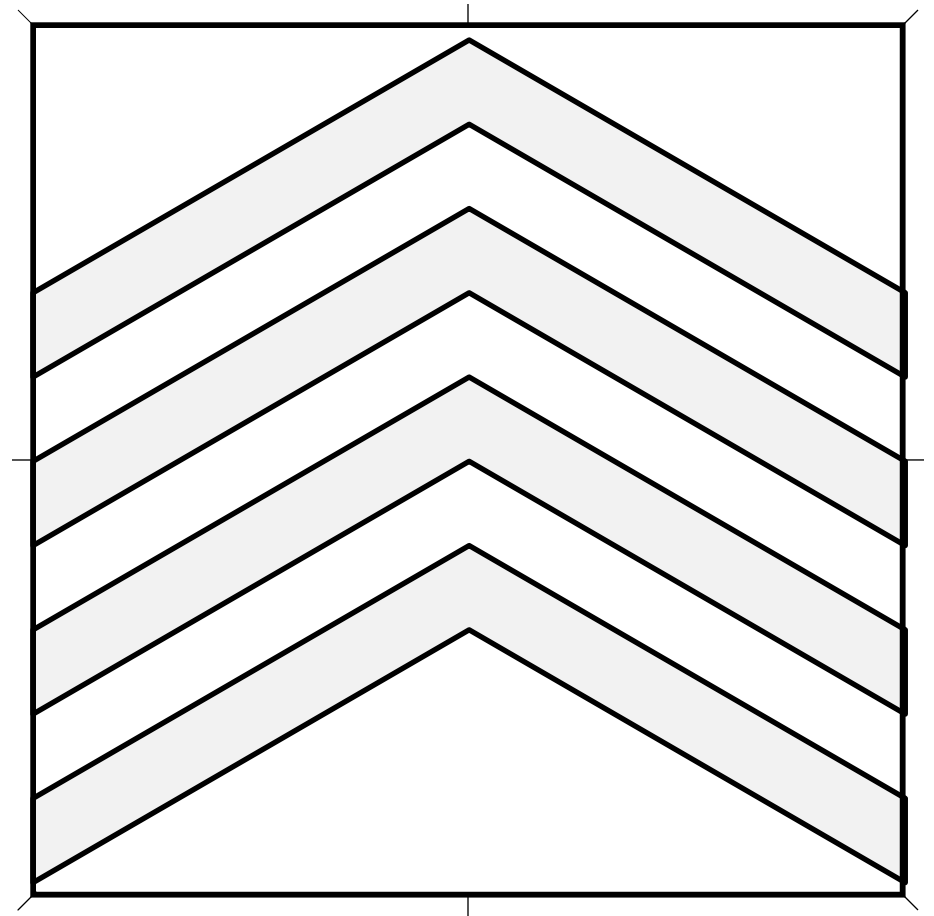
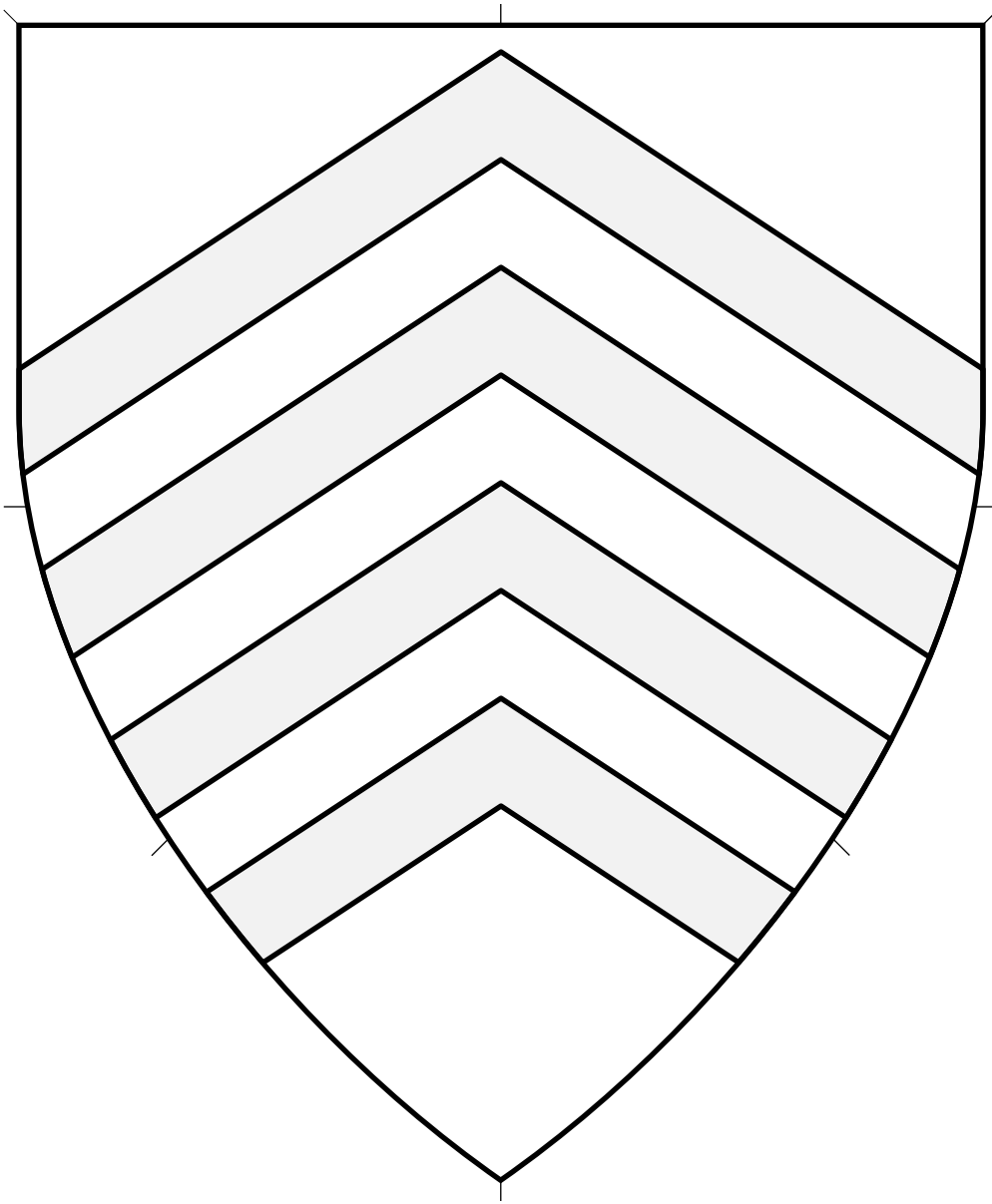

Central ordinary.

Source: Wapenboek van Gent. Artist: Vander Schelden. (Volume 1, page 128.)

Chevronels, 4 (2) 4.259

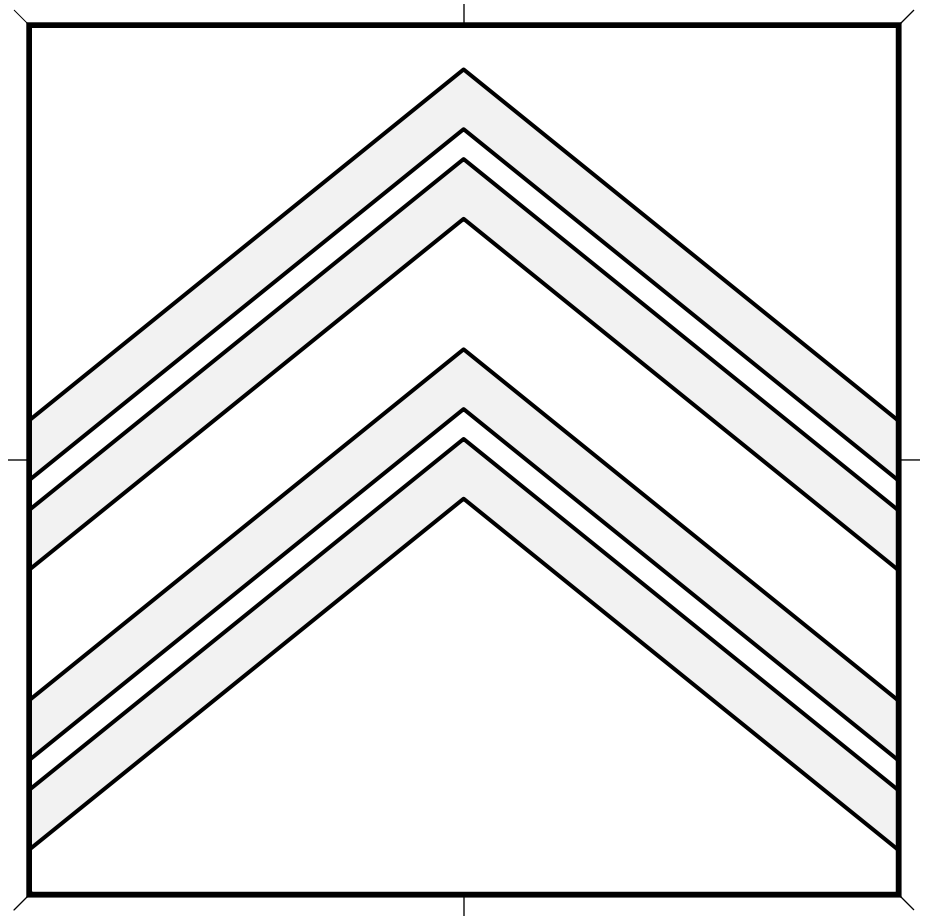
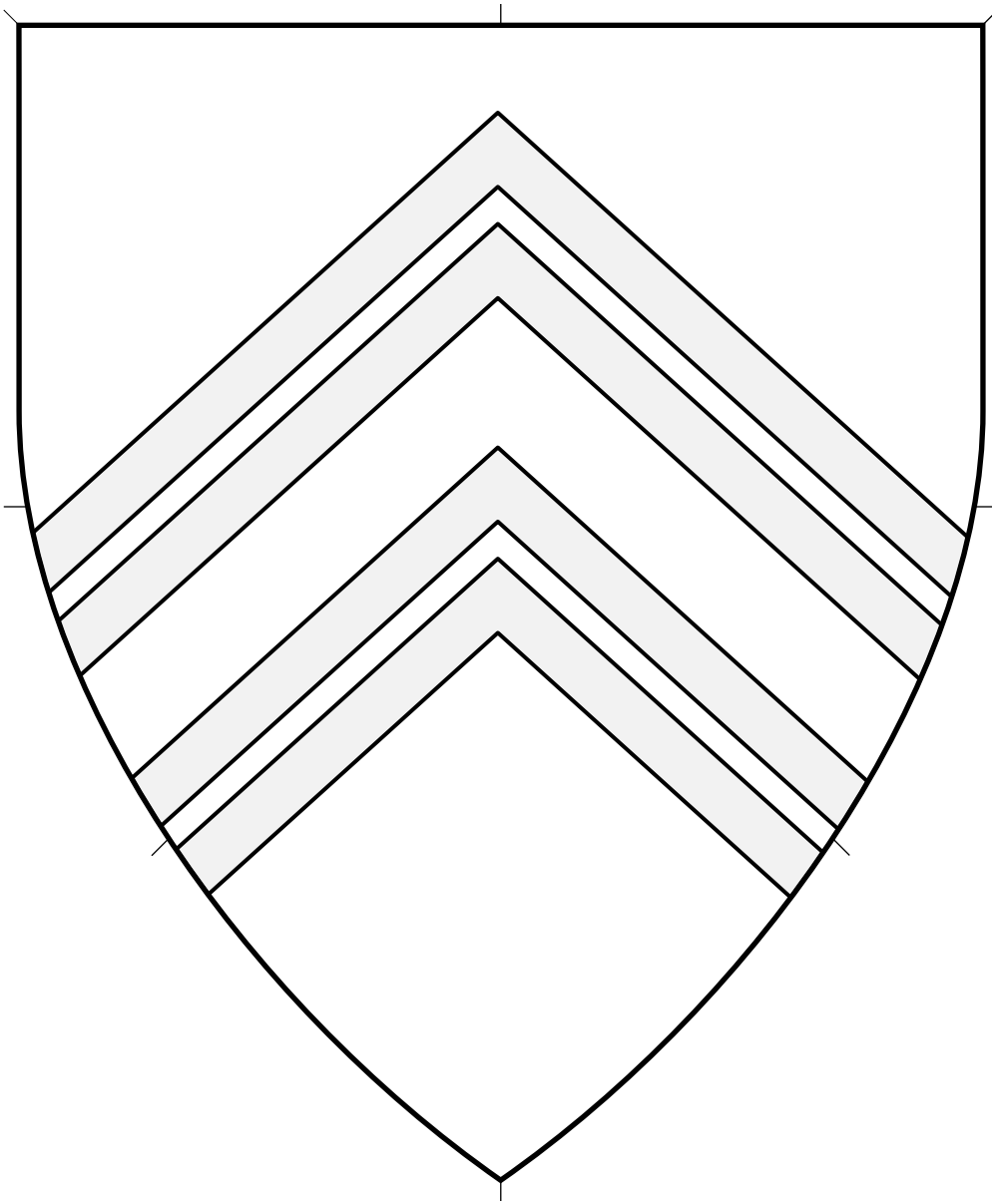

Central ordinary.

Chevronels Gemel, Two 4.260

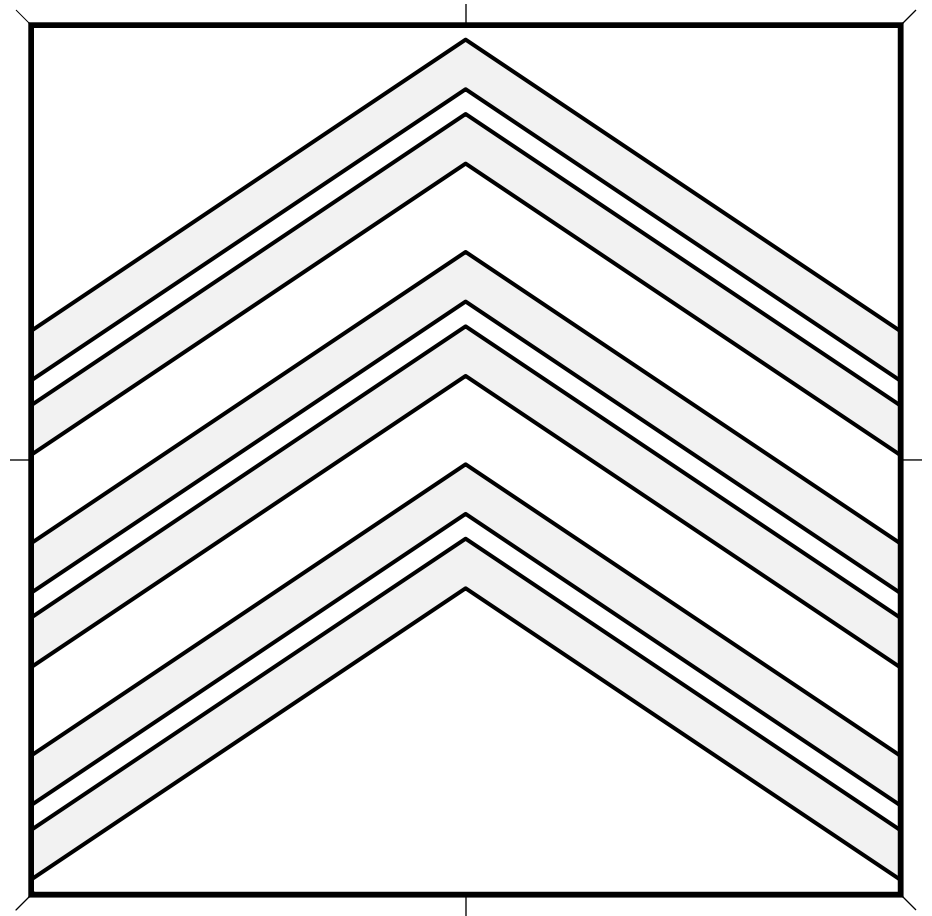
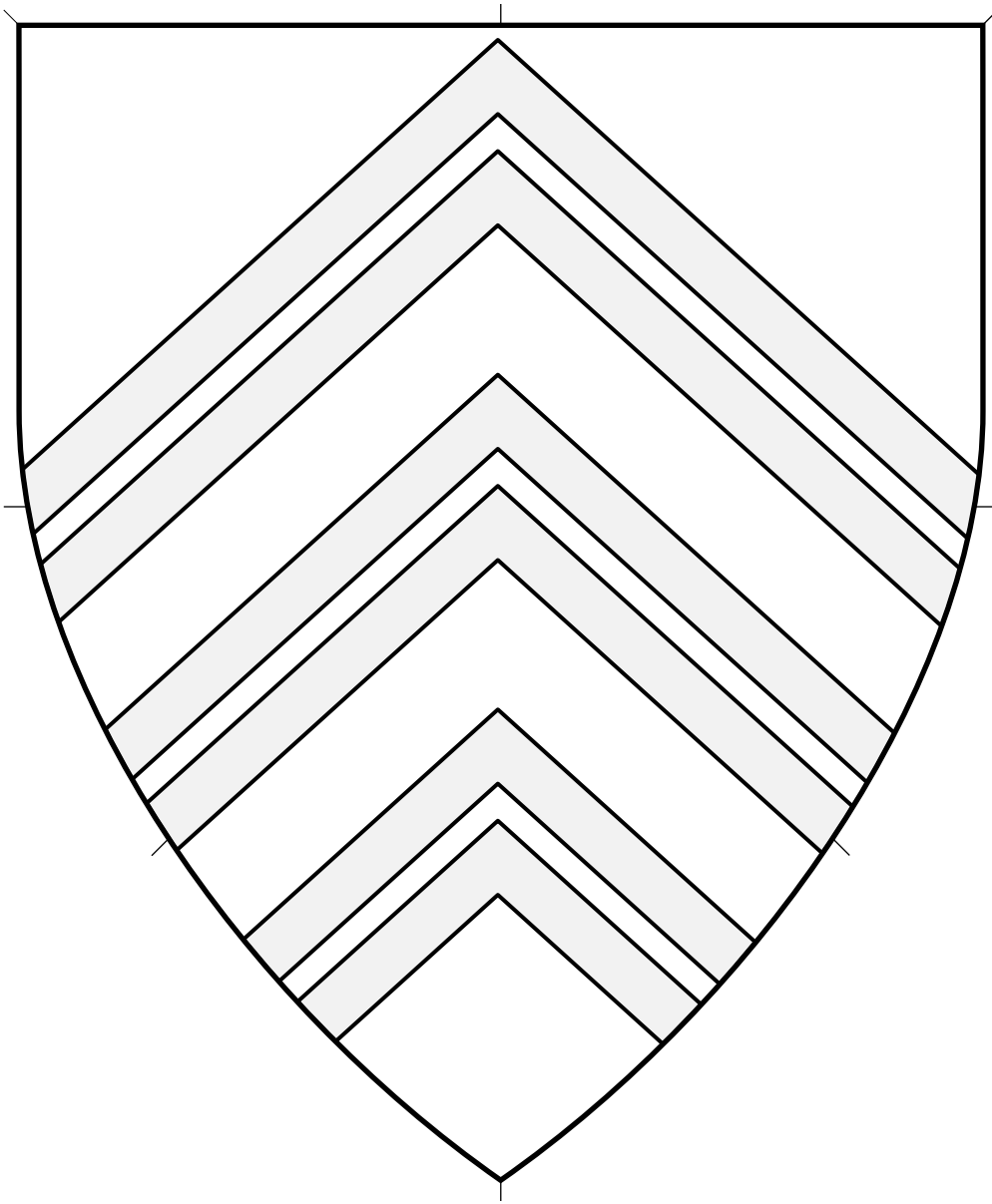

Central ordinary.

Source: Recueil d'Armoiries Coloriées. Artist unknown.

Chevronels Gemel, Three 4.261

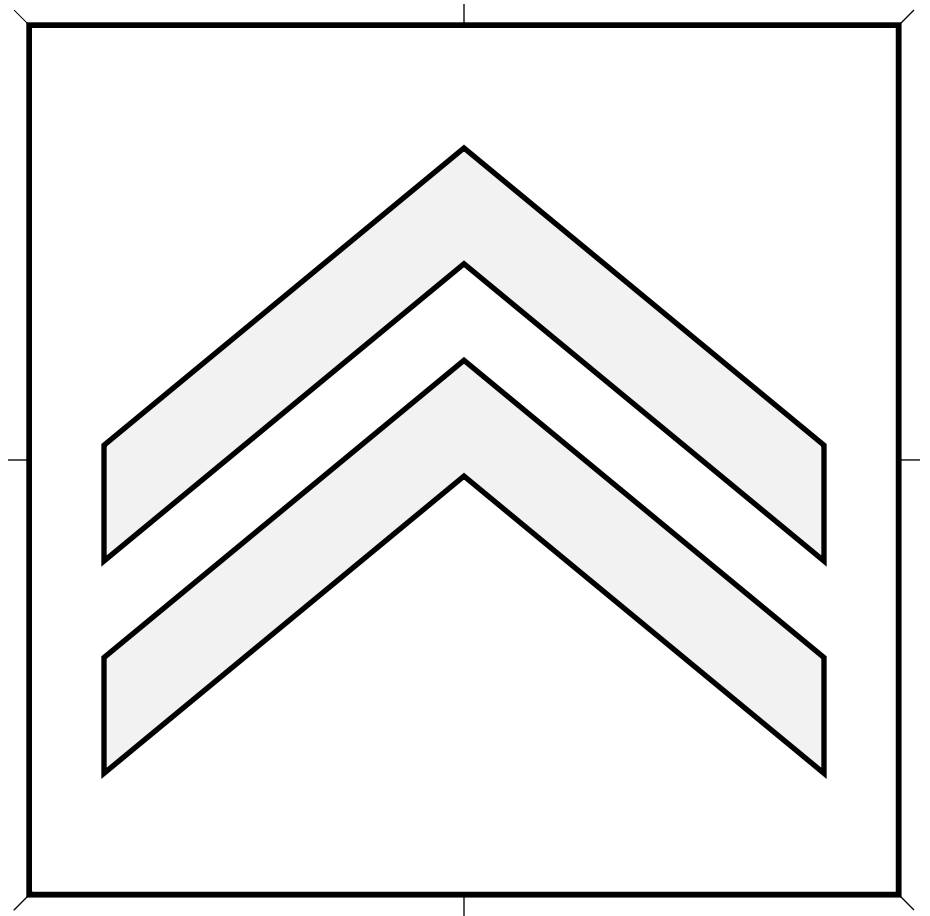
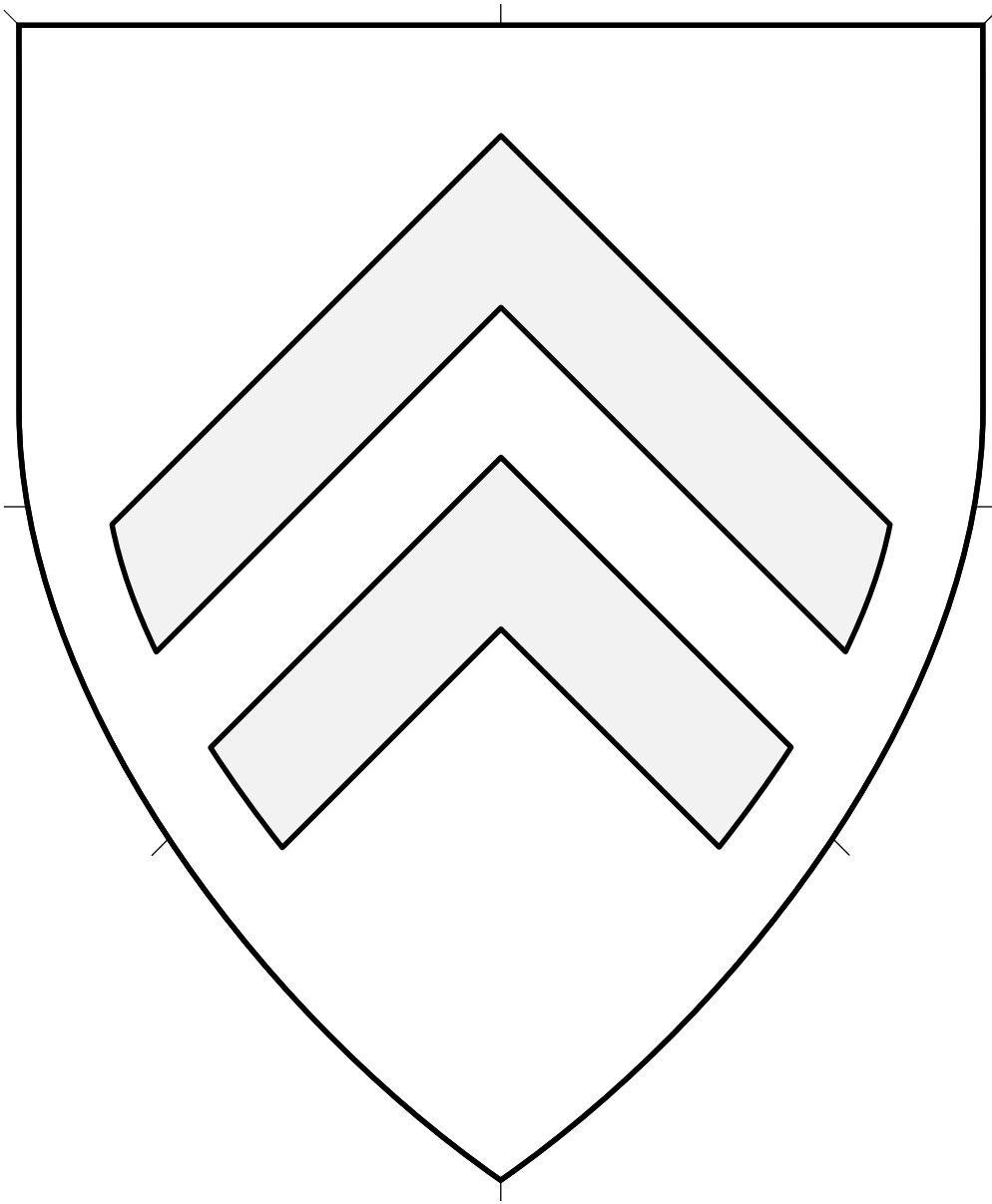

Central ordinary. The term "humetty" indicates that edges of the ordinary are couped parallel to the border of the field.

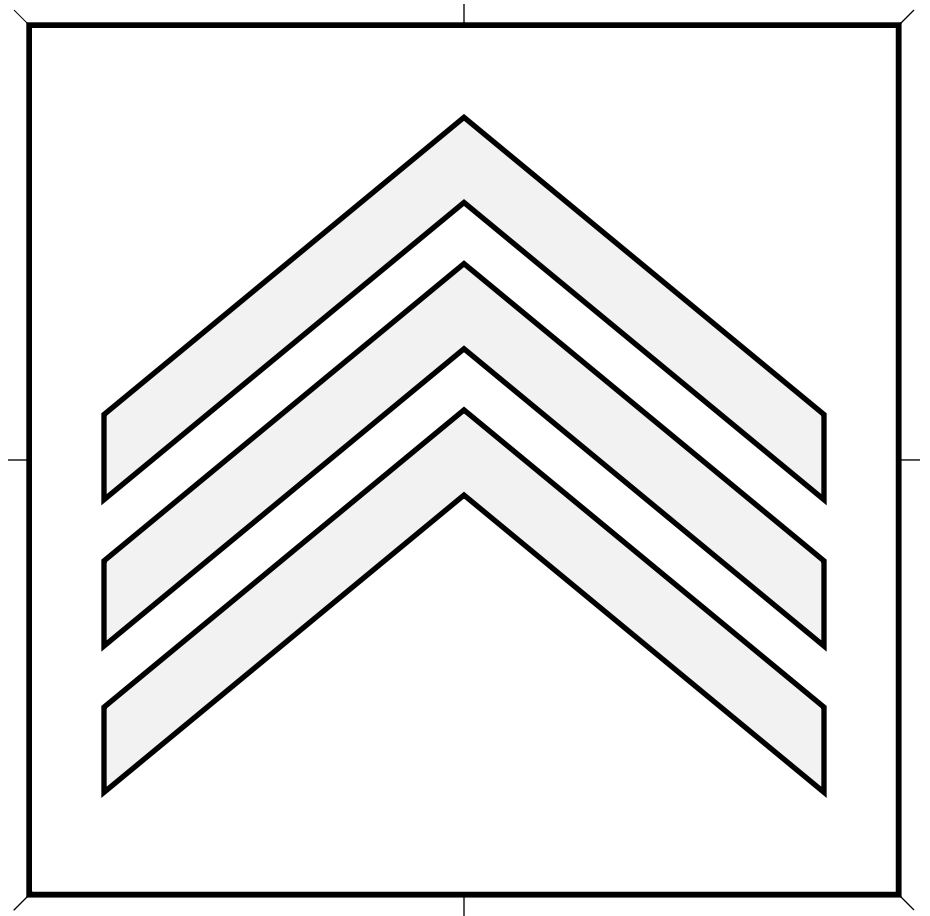
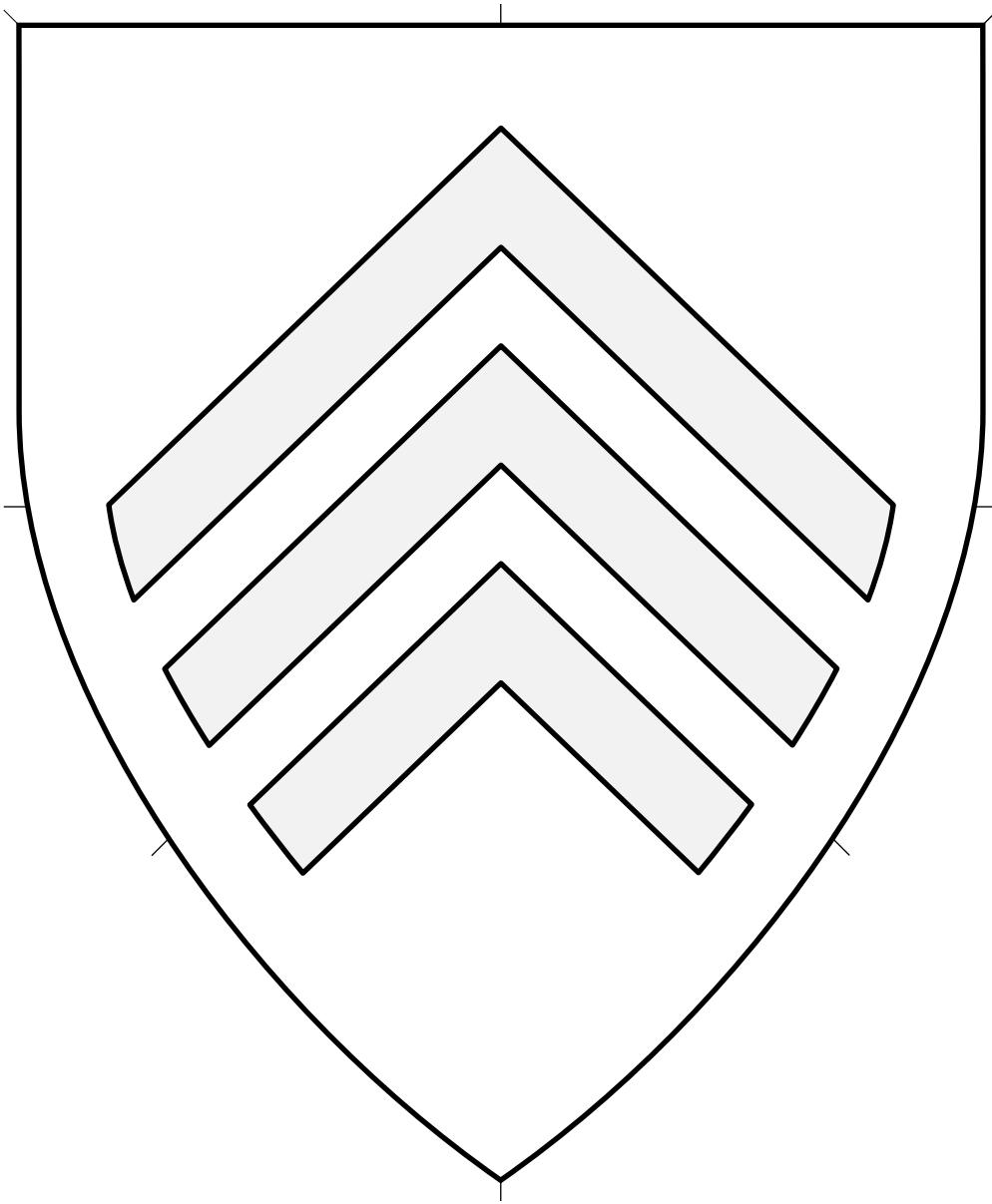

Central ordinary. The term "humetty" indicates that edges of the ordinary are couped parallel to the border of the field.

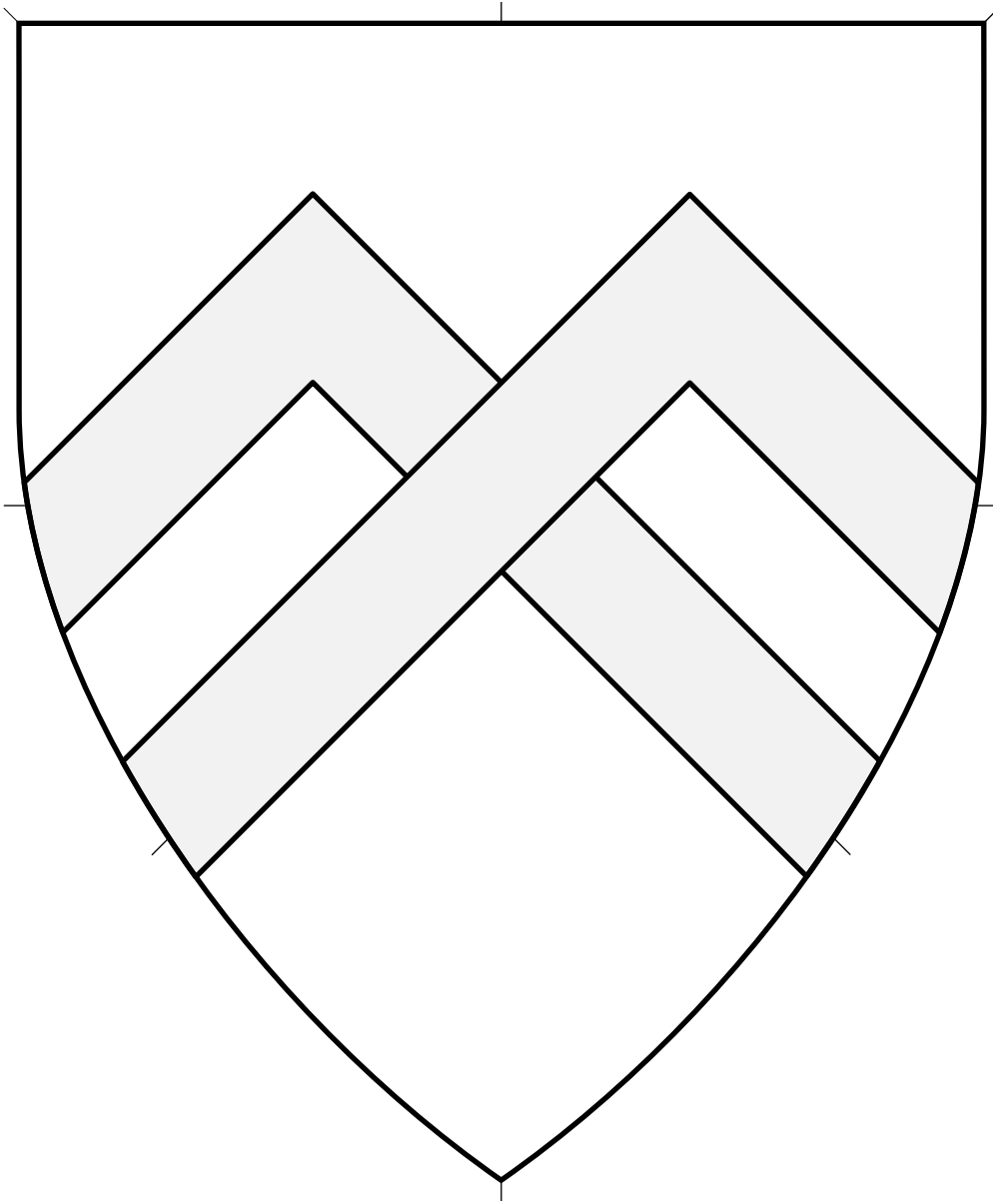

Central ordinary.

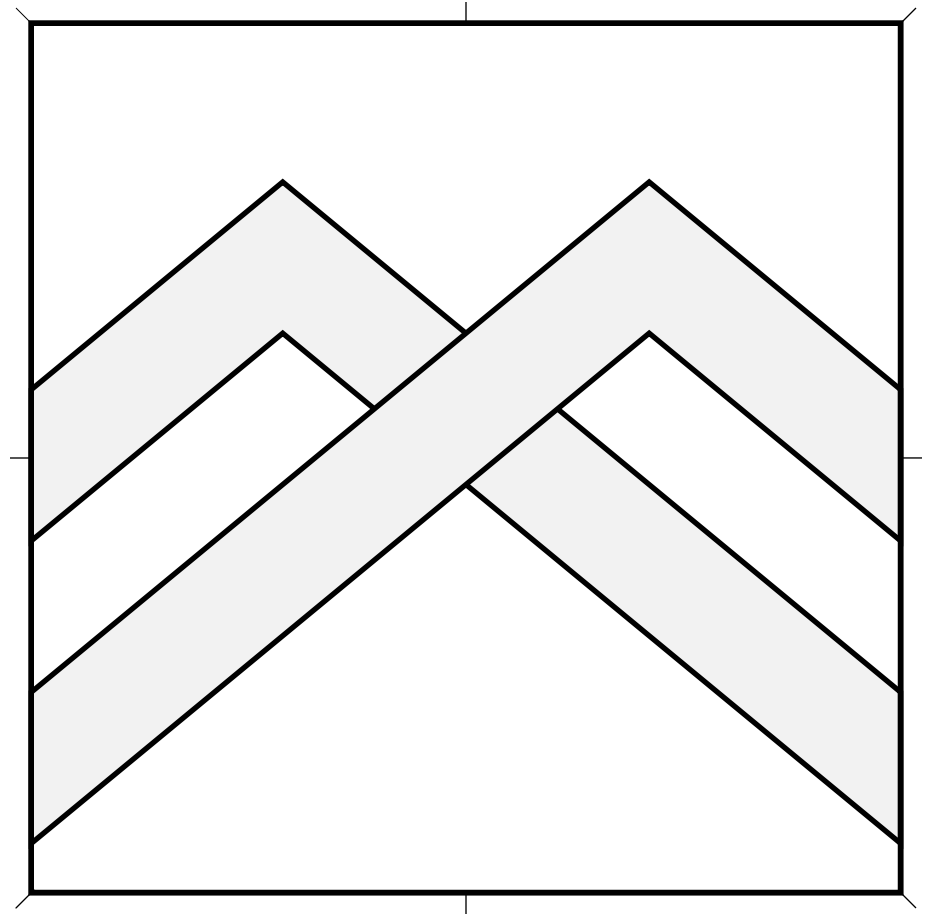

Chevronels Braced, 2 4.264

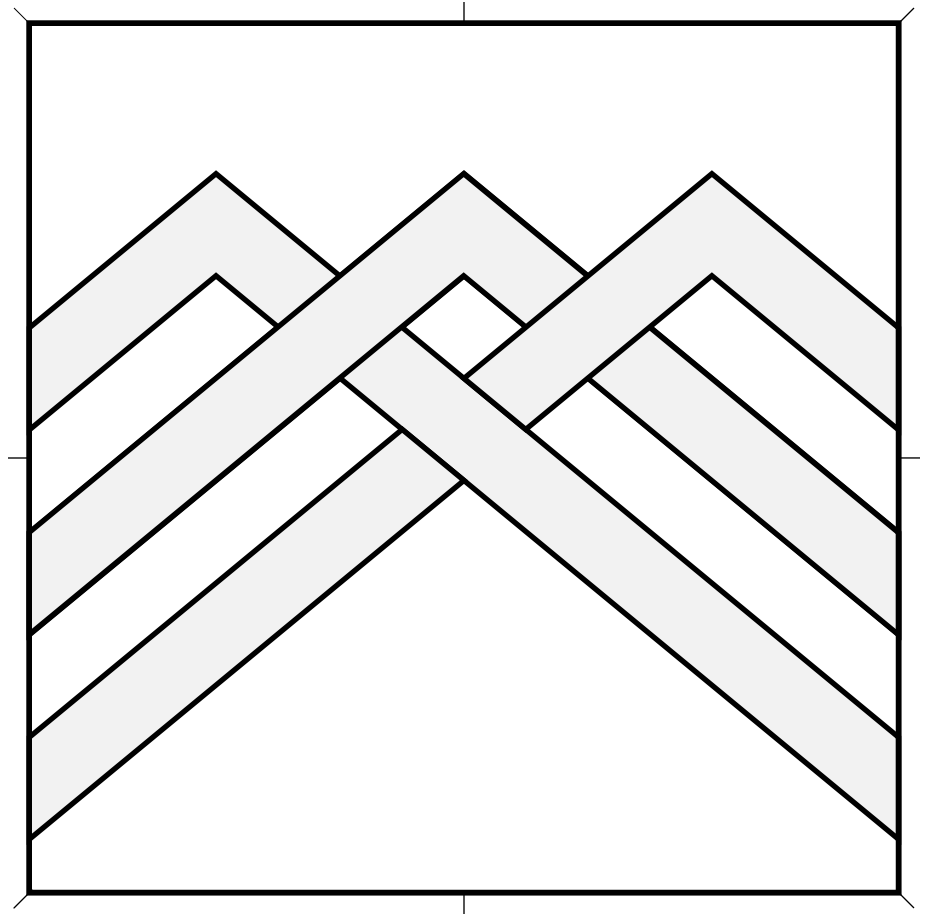
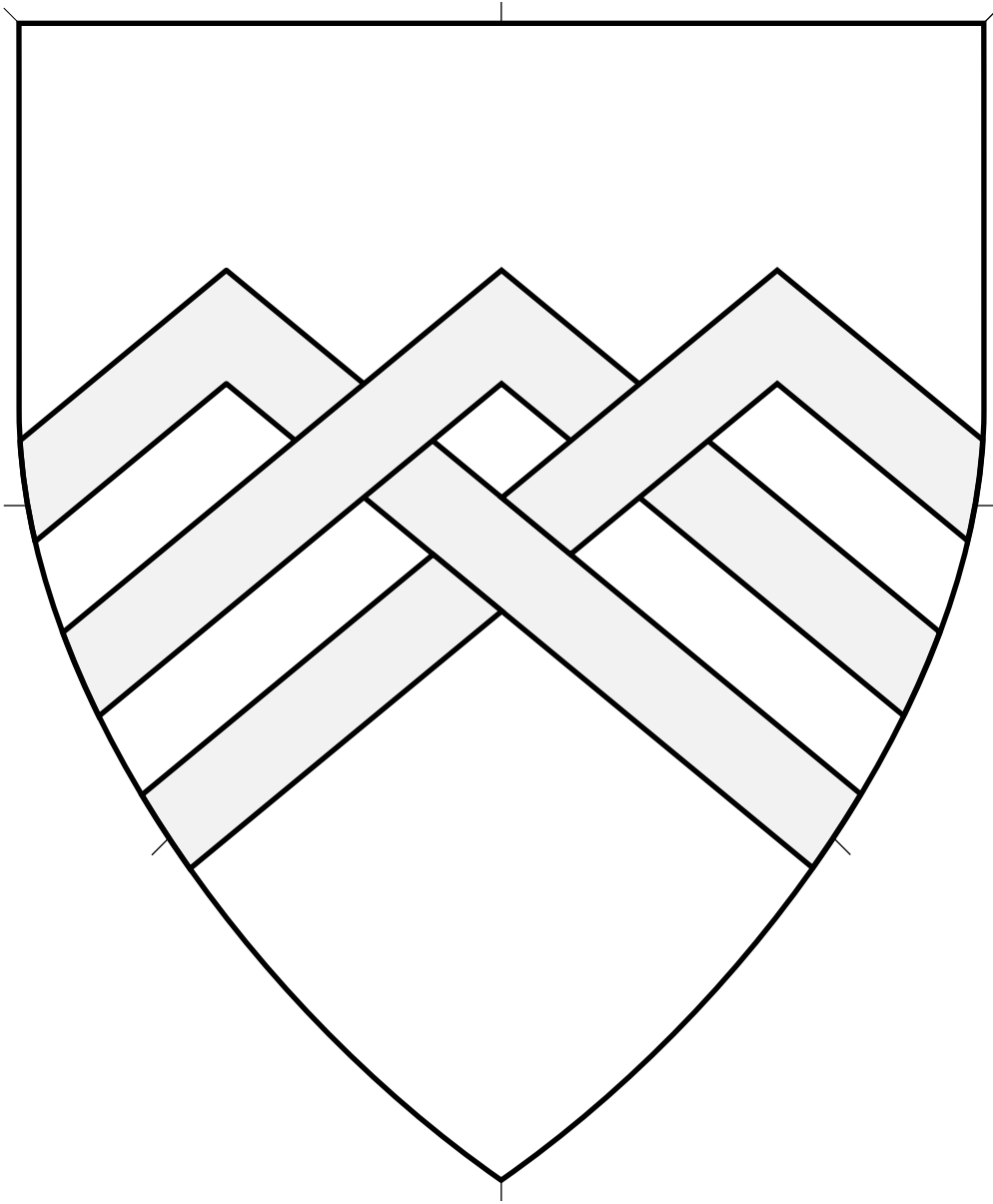

Central ordinary.

Chevronels Braced, 3 (1) 4.265

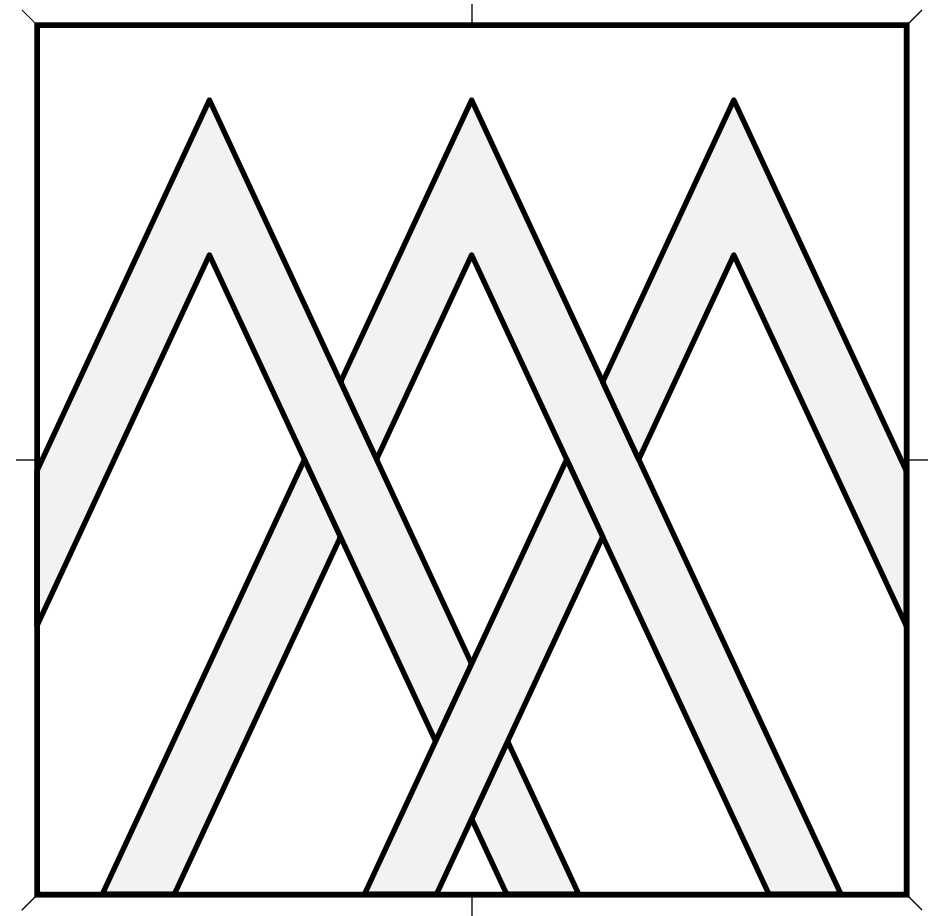
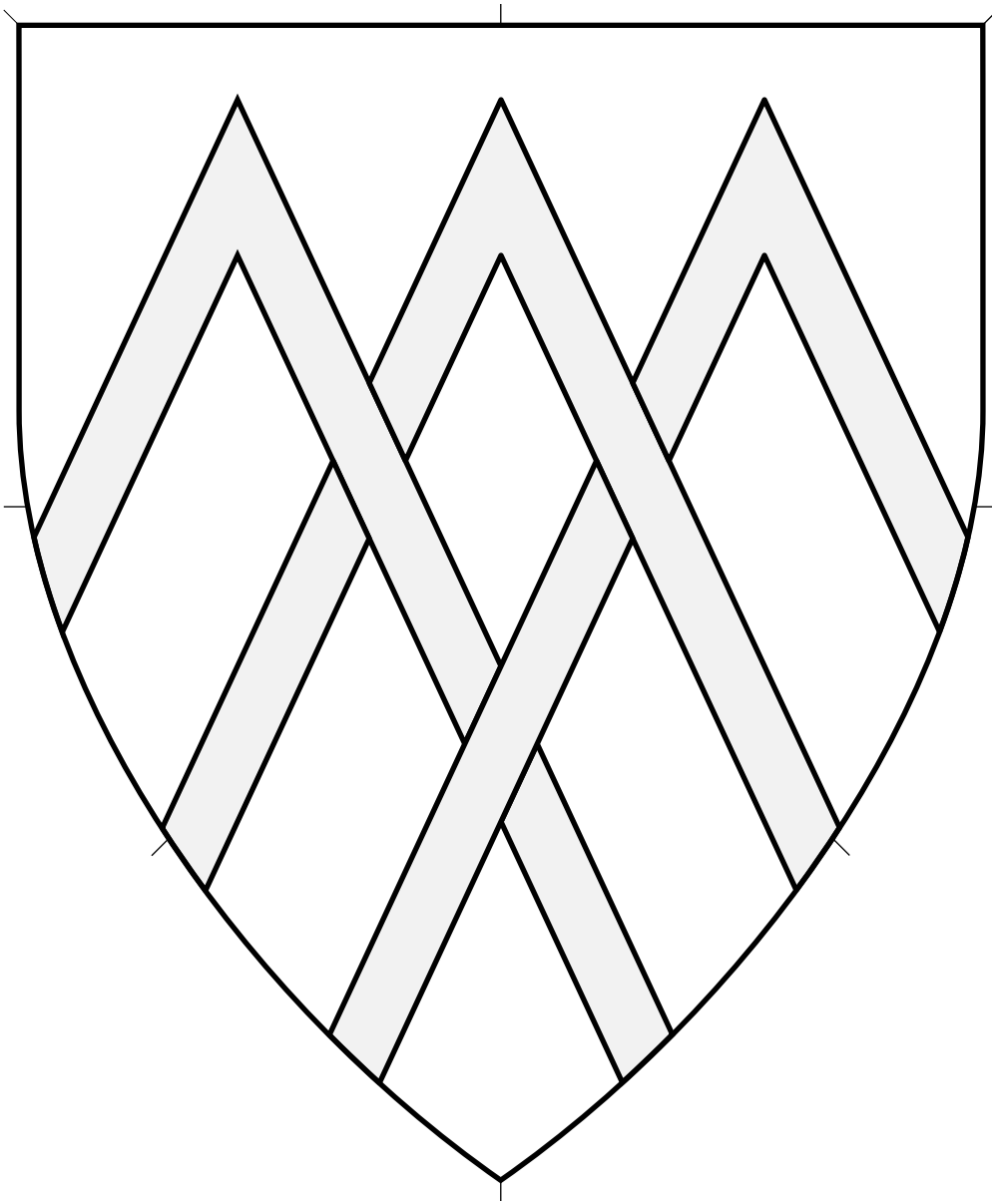

Central ordinary.

Source: BnF MS Allemand 304.
Artist unknown. (Page 734.)

Chevronels Braced, 3 (2) 4.266

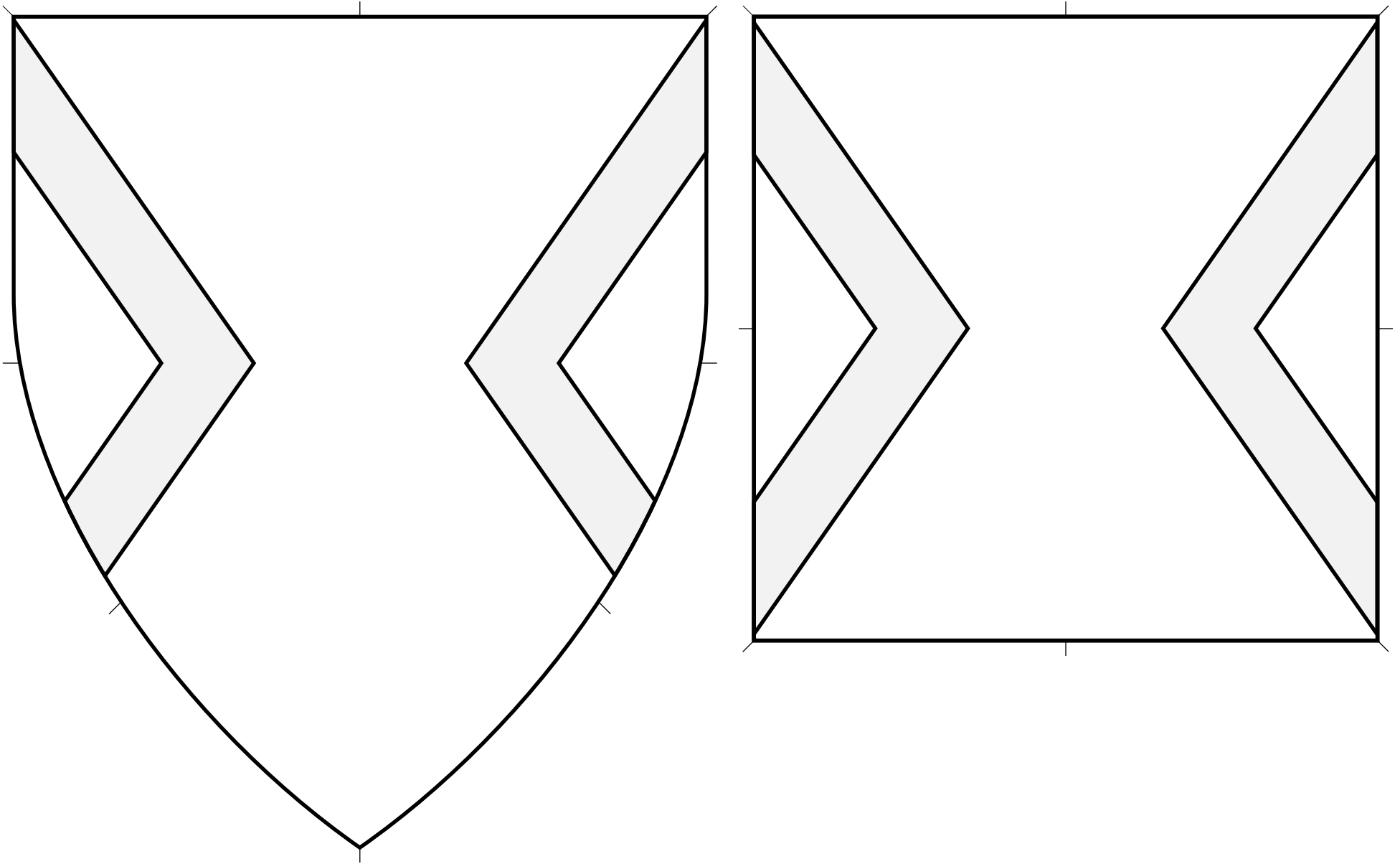

Central ordinary.

Source: Armas de los Cavalleros de Venecia. Artist unknown. (Folio 85r.)

Chevronels Couched from the Flanks, 2 4.267

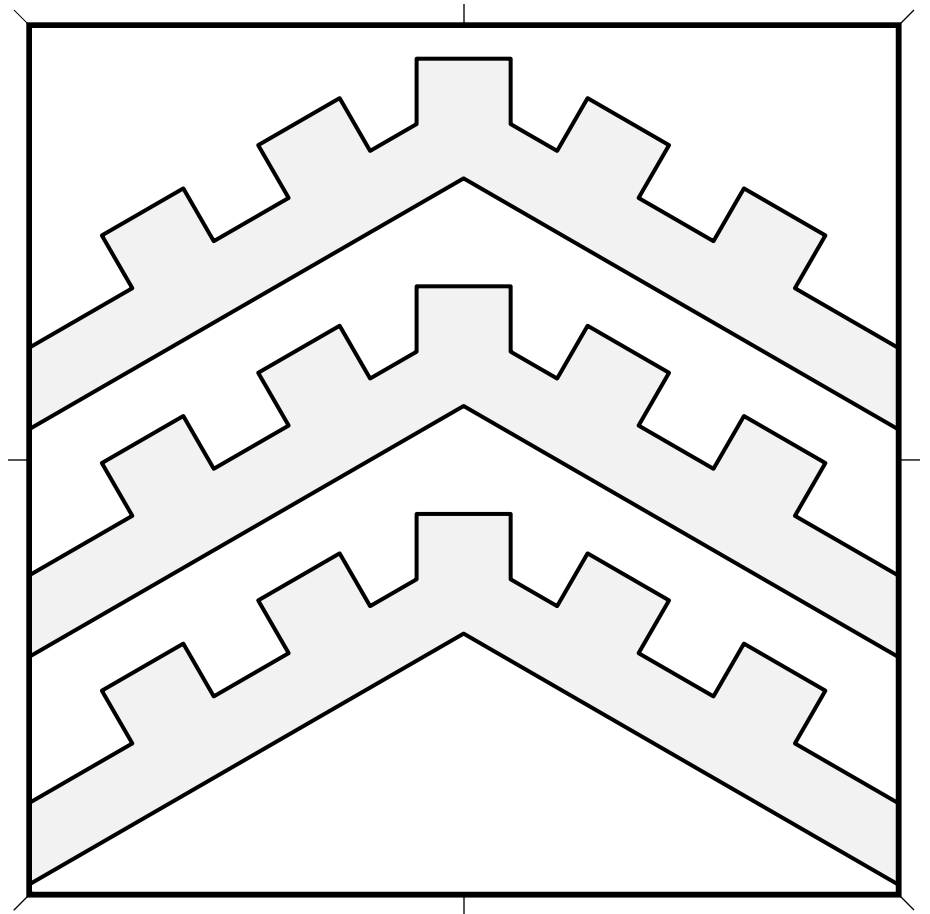
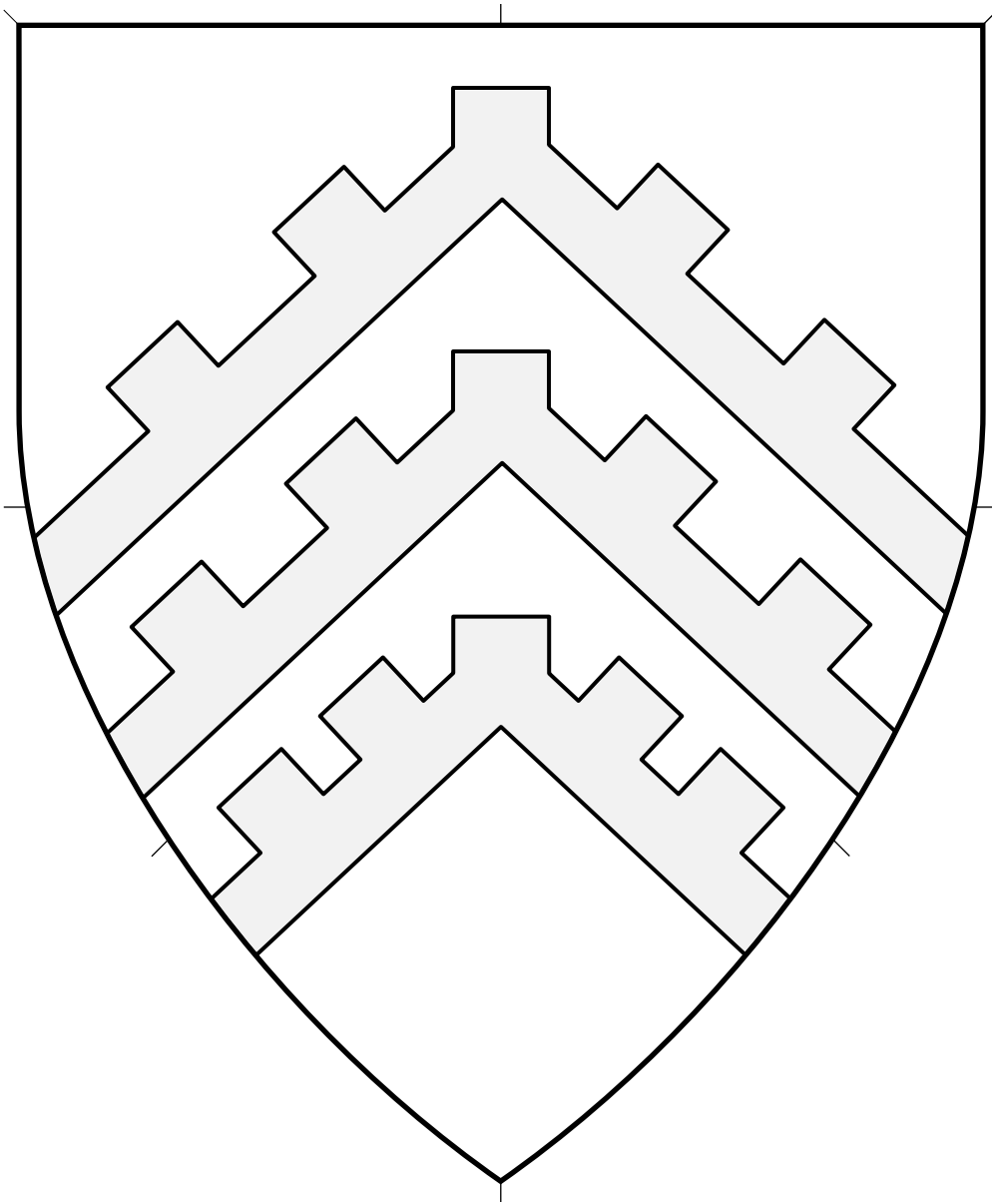

Central ordinary.

Source: BnF MS Allemand 304.
Artist unknown. (Page 574.)

Chevronels Embattled, 3 4.268

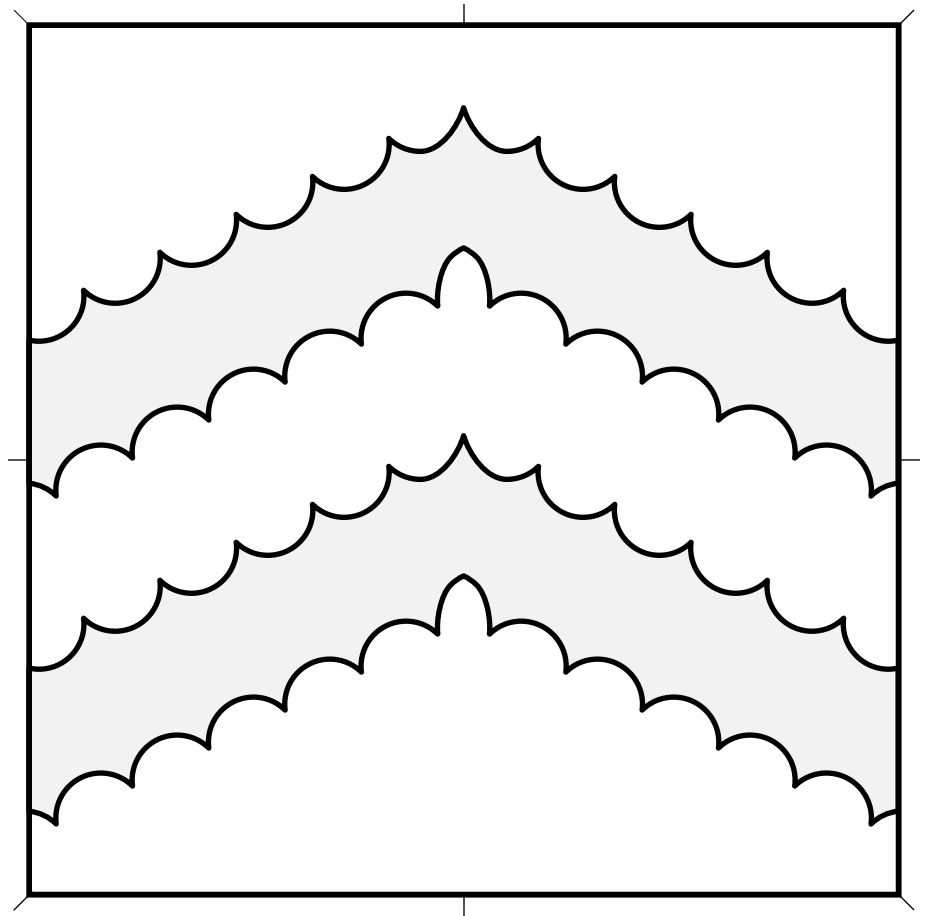
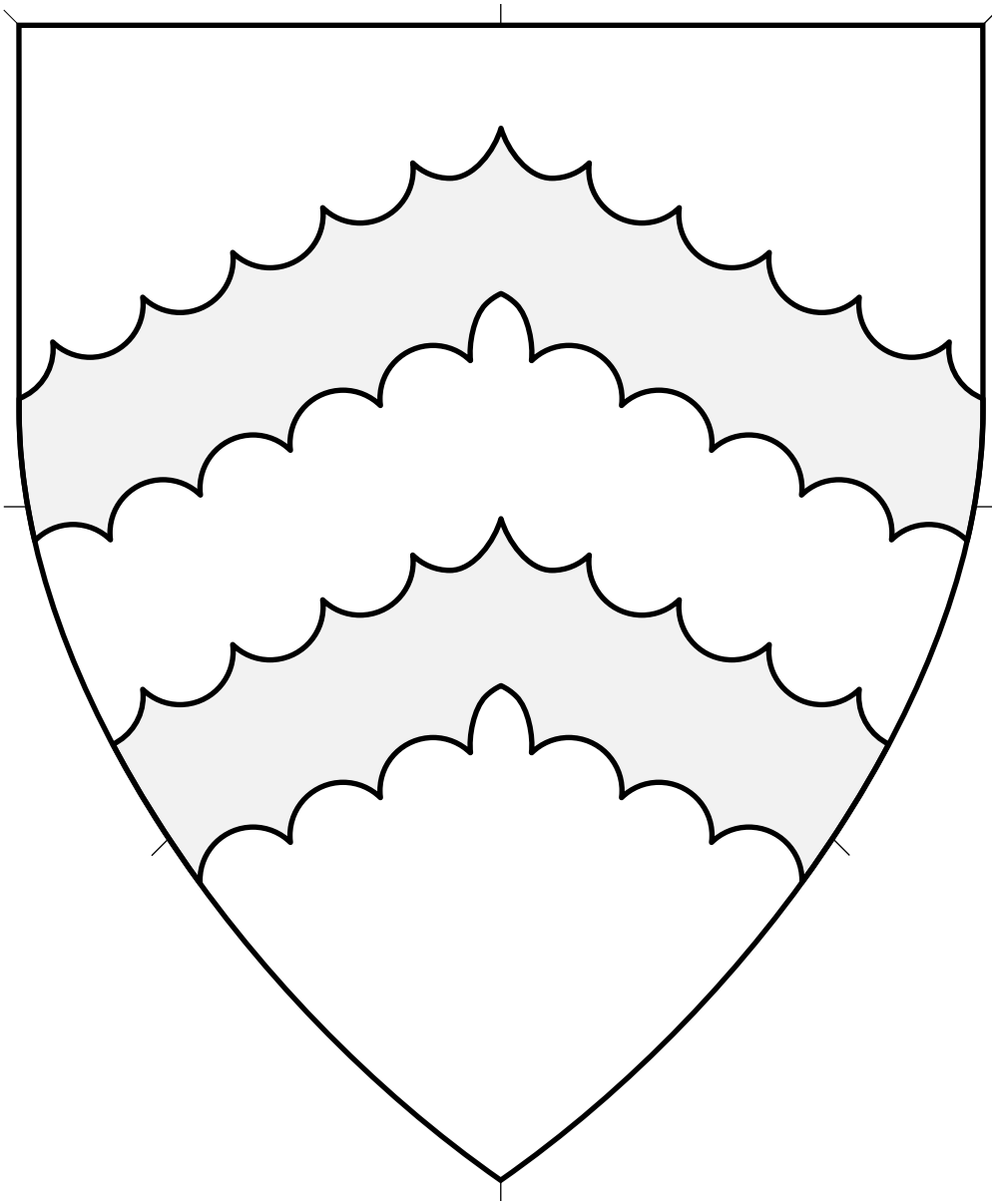

Central ordinary.

Source: English Arms A. Artist unknown. (Page 73.)

Chevronels Engrailed, 2 4.269

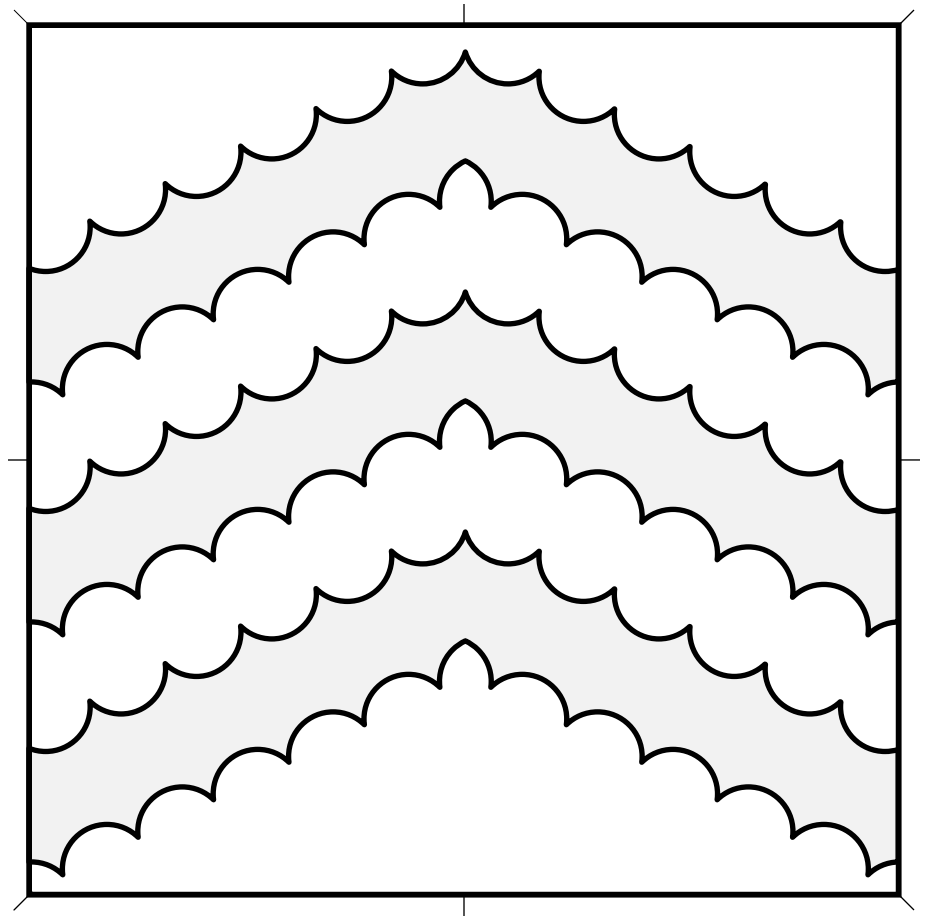
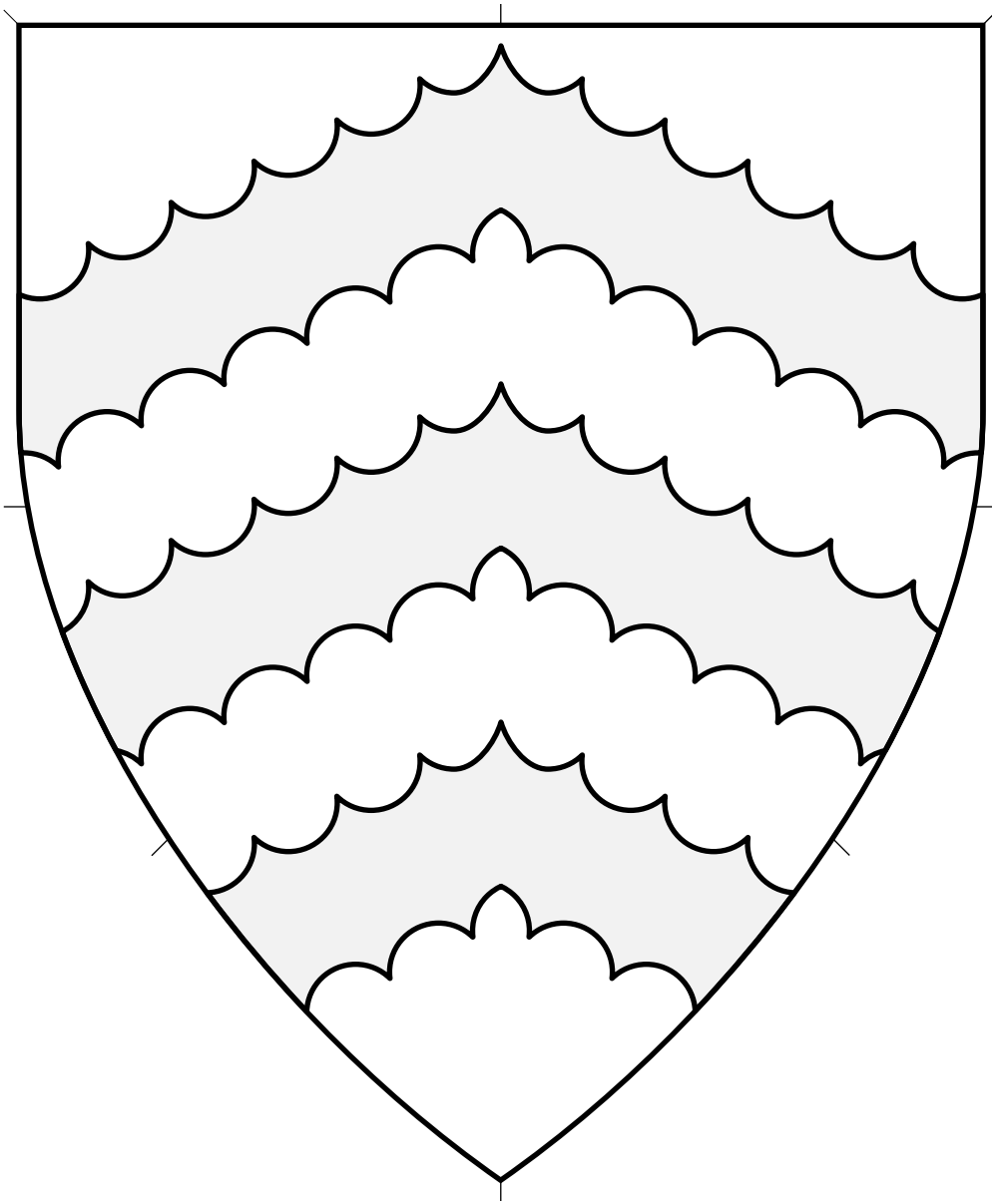

Central ordinary.

Source: English Arms A. Artist unknown. (Page 73.)

Chevronels Engrailed, 3 4.270

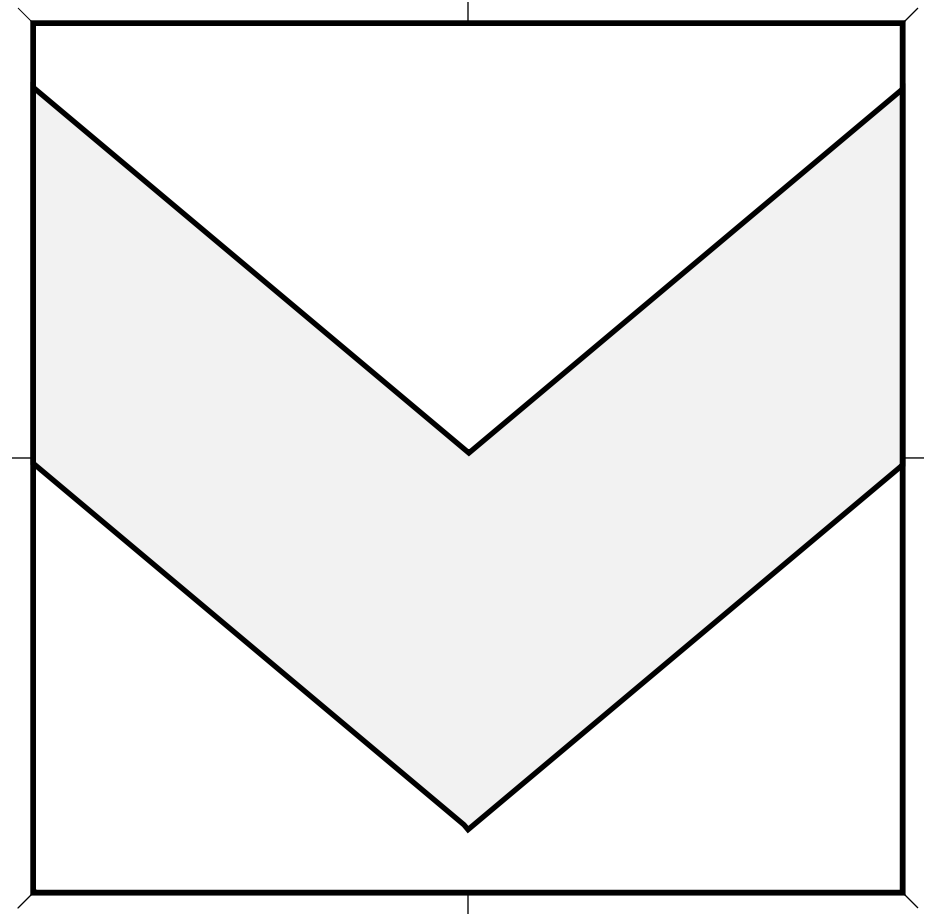
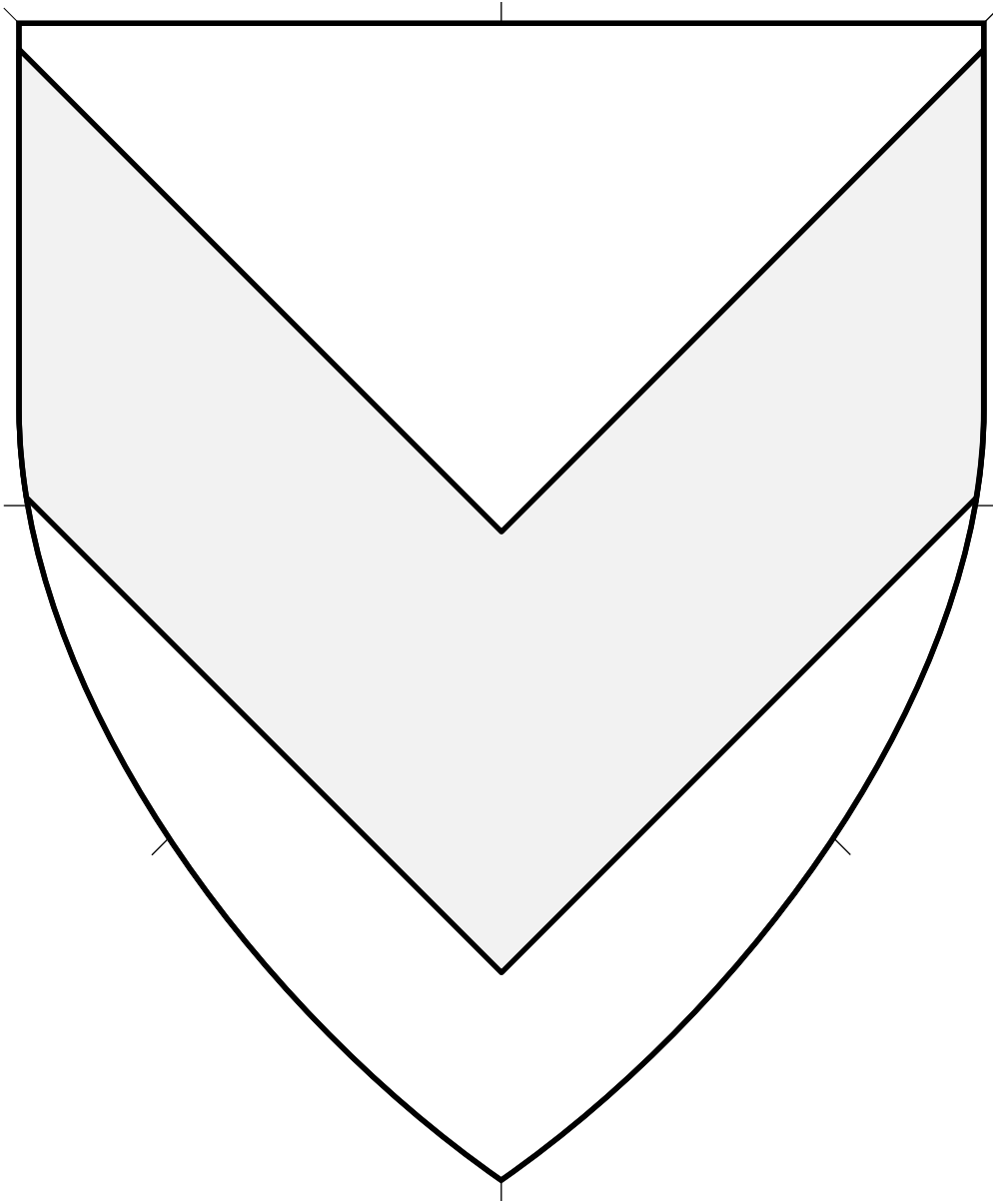

Central ordinary. Must issue from sides of device. Must be centered on the fess line, except if shifted up or down to accommodate secondary charges. Angle may be narrower or wider than 90°. The thickness of each arm is typically between a third to a fifth of the width of the device.

Chevron Inverted (1) • 4.271

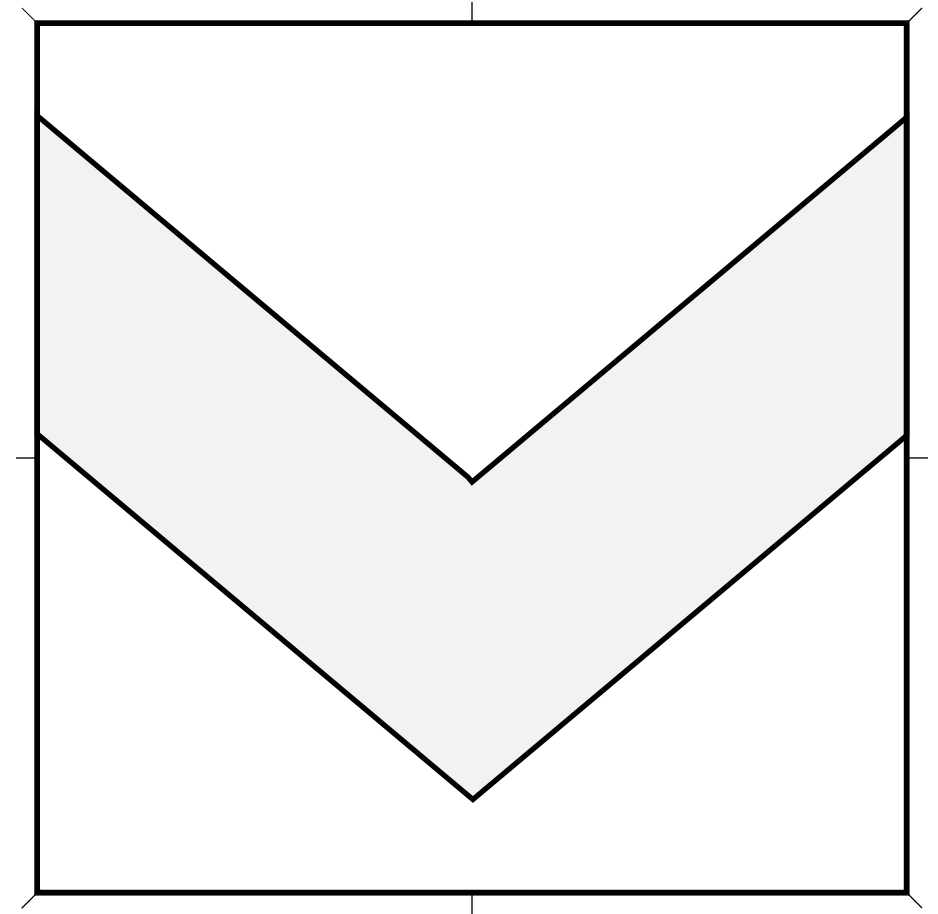
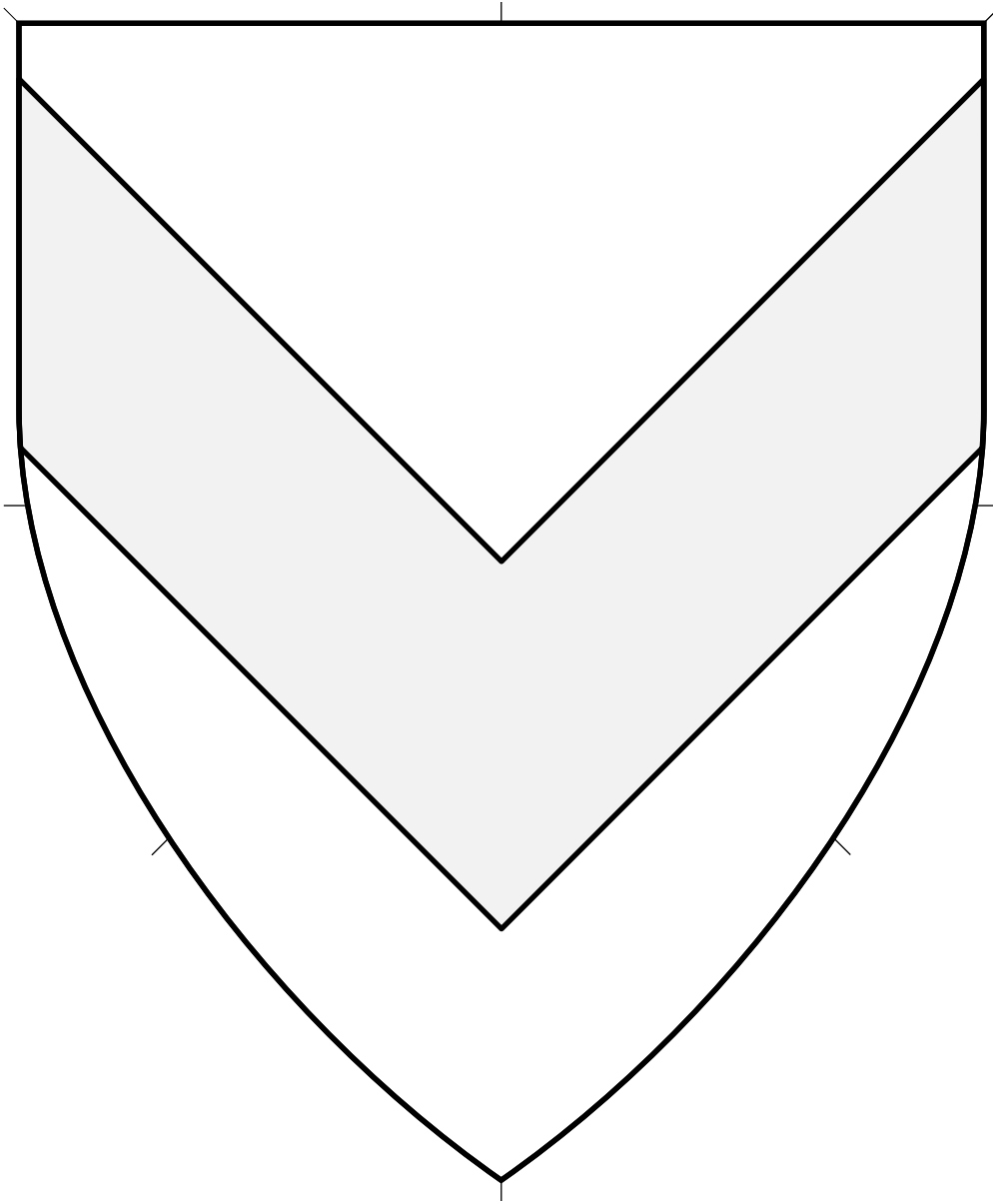

Central ordinary. Must issue from sides of device. Must be centered on the fess line, except if shifted up or down to accommodate secondary charges. Angle may be narrower or wider than 90°. The thickness of each arm is typically between a third to a fifth of the width of the device.

Chevron Inverted (2) 4.272

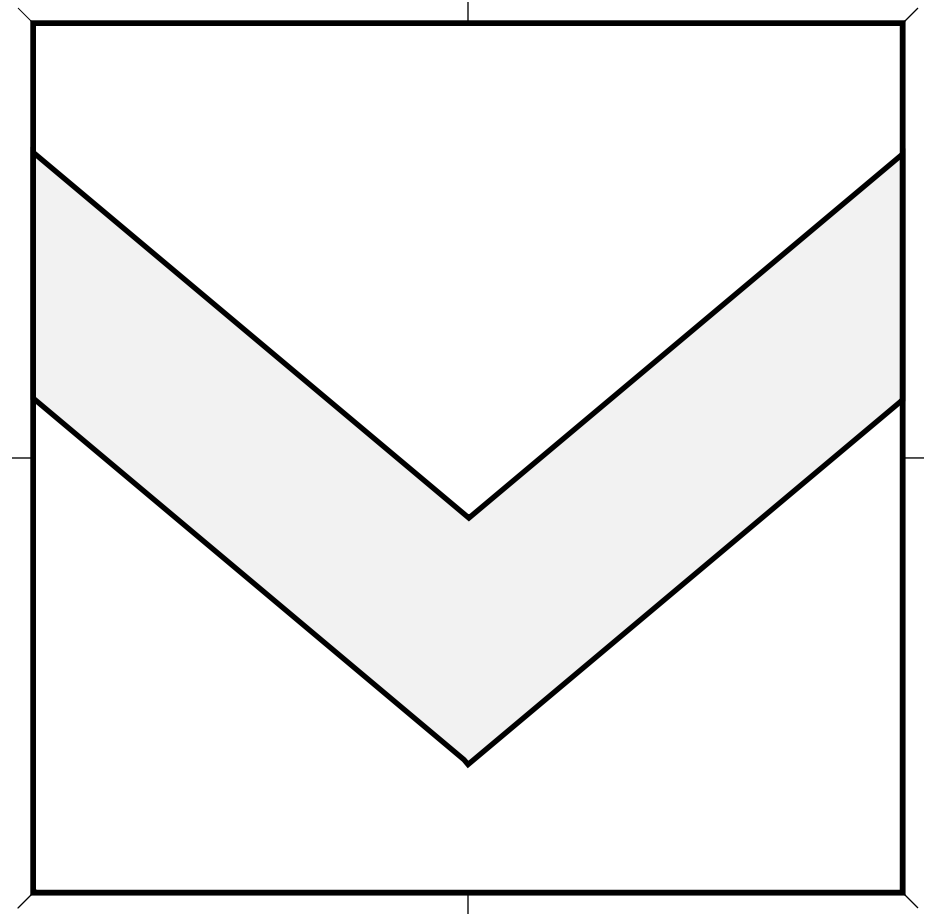
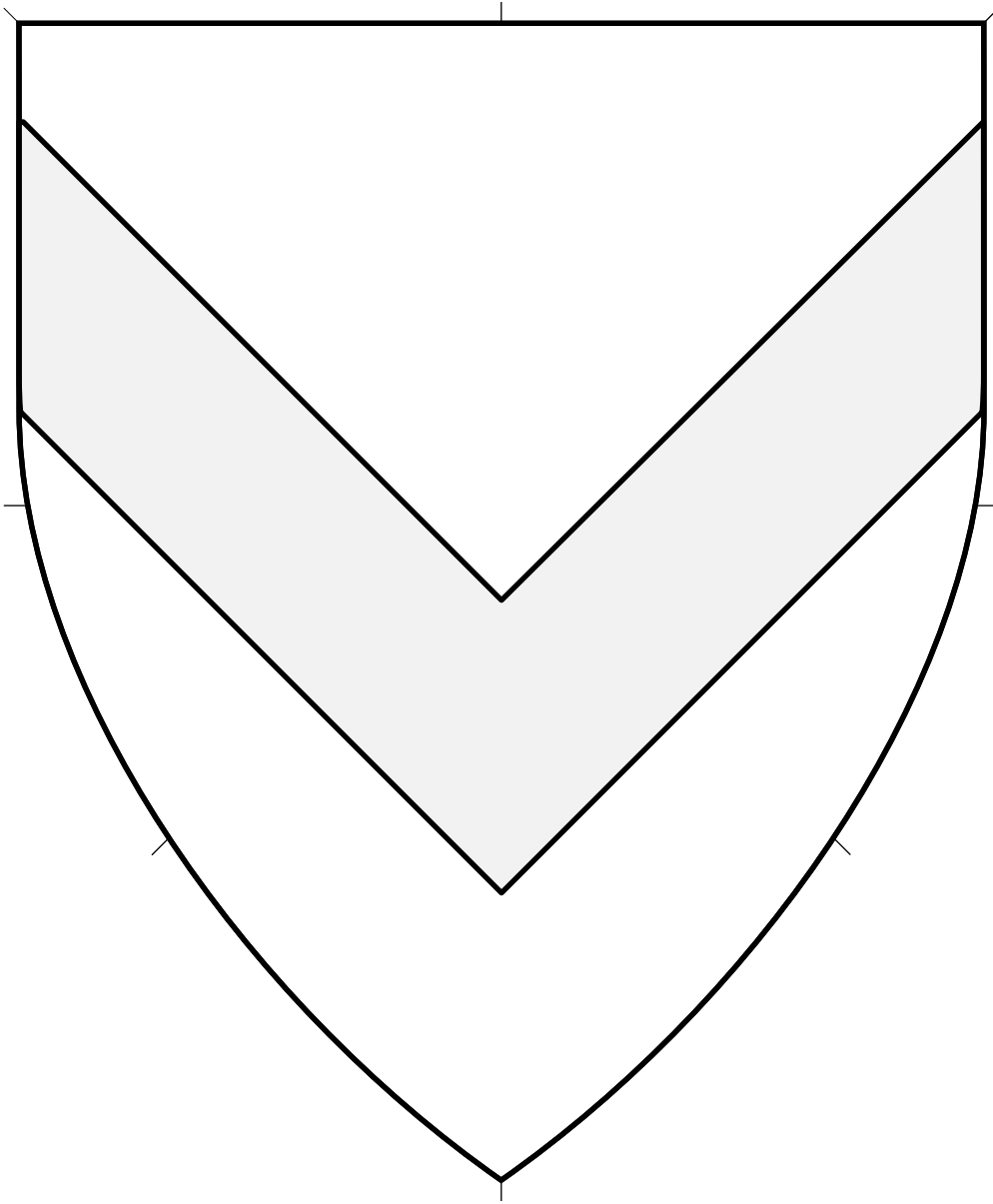

Central ordinary. Must issue from sides of device. Must be centered on the fess line, except if shifted up or down to accommodate secondary charges. Angle may be narrower or wider than 90°. The thickness of each arm is typically between a third to a fifth of the width of the device.

Chevron Inverted (3) 4.273

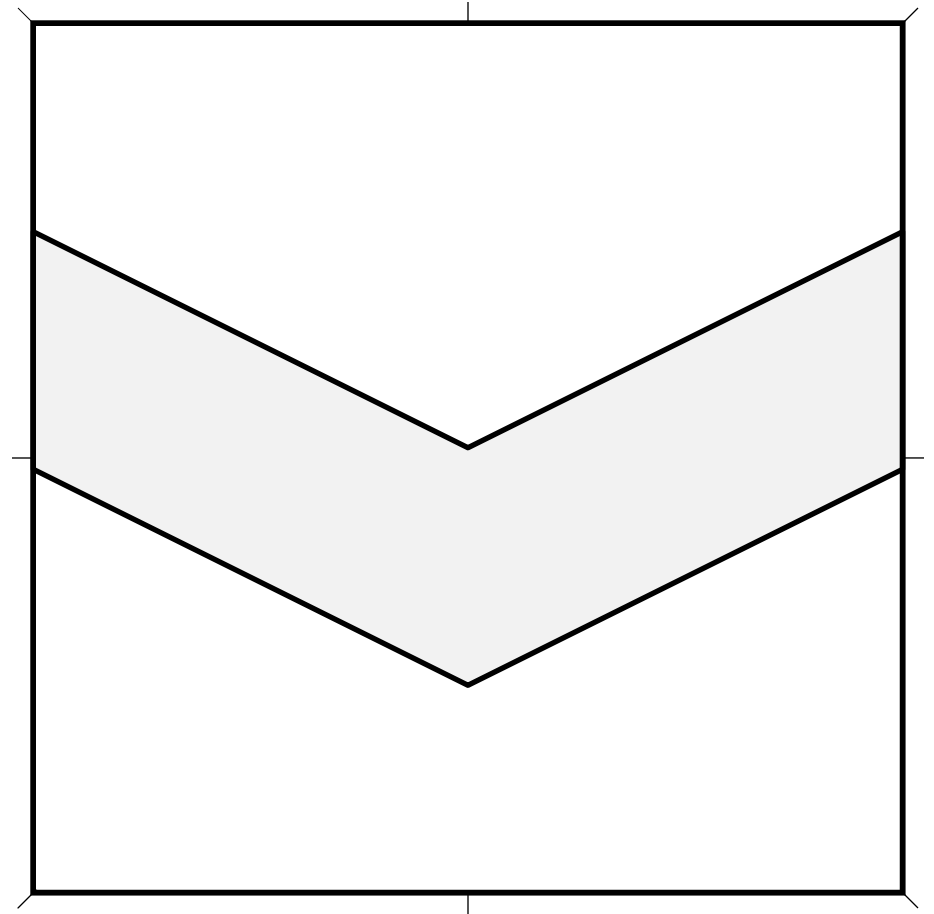
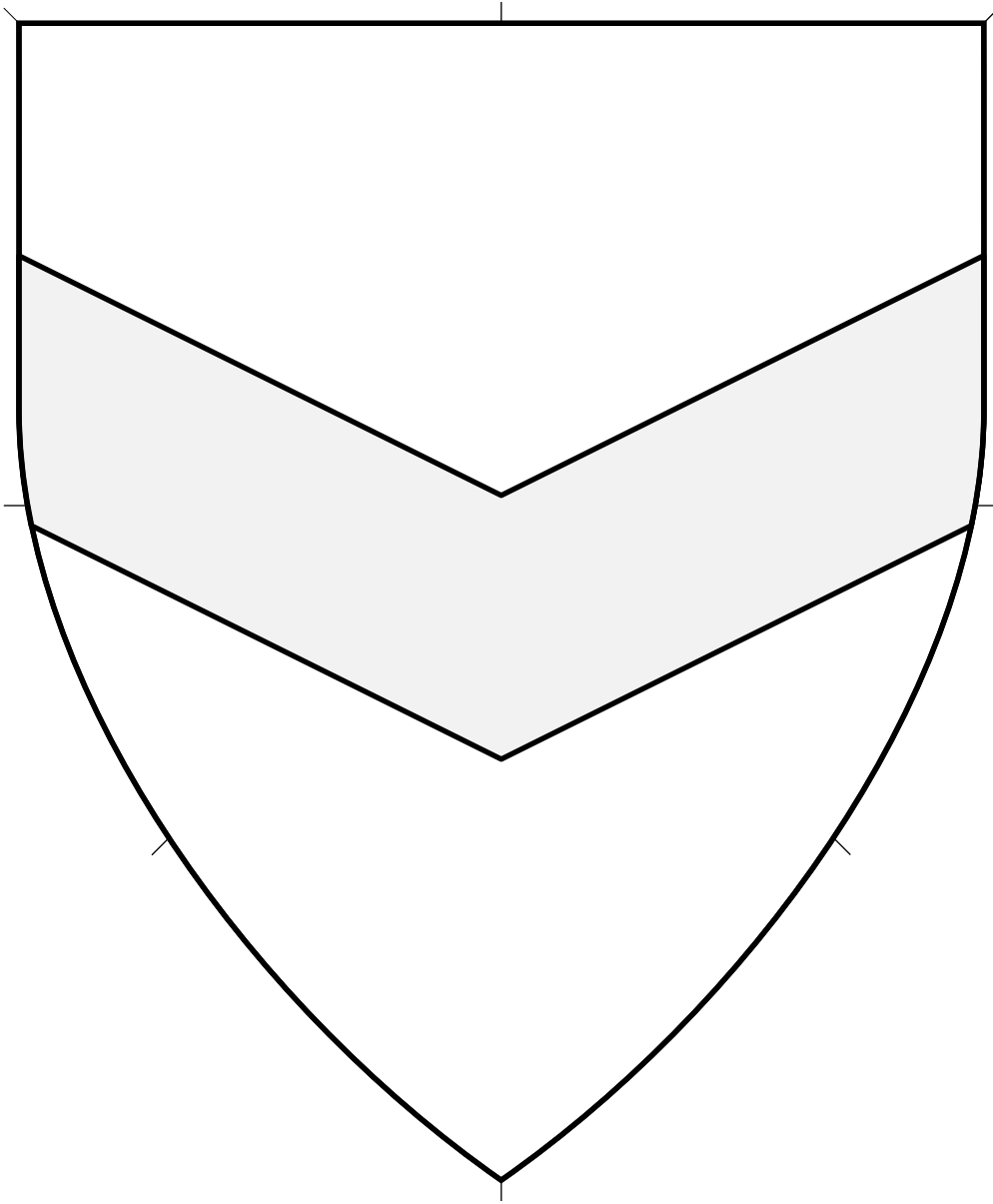

Central ordinary. Must issue from sides of device. Must be centered on the fess line, except if shifted up or down to accommodate secondary charges. Angle may be narrower or wider than 90°. The thickness of each arm is typically between a third to a fifth of the width of the device.

Chevron Inverted (4) 4.274

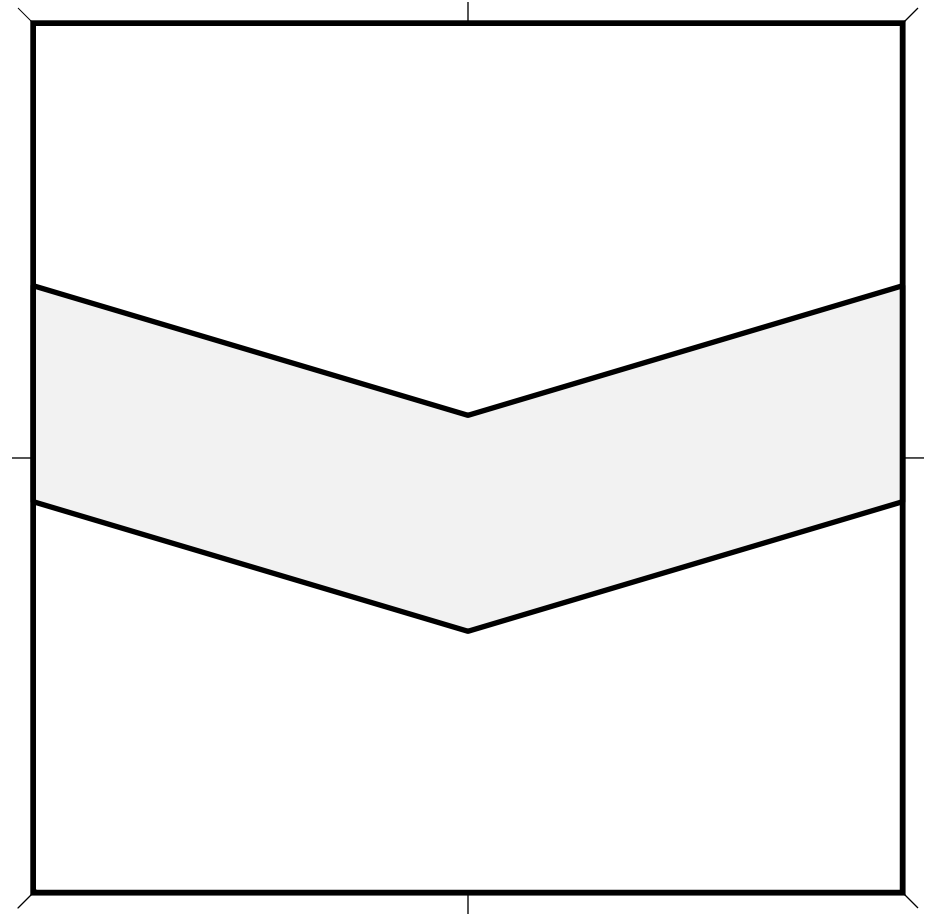
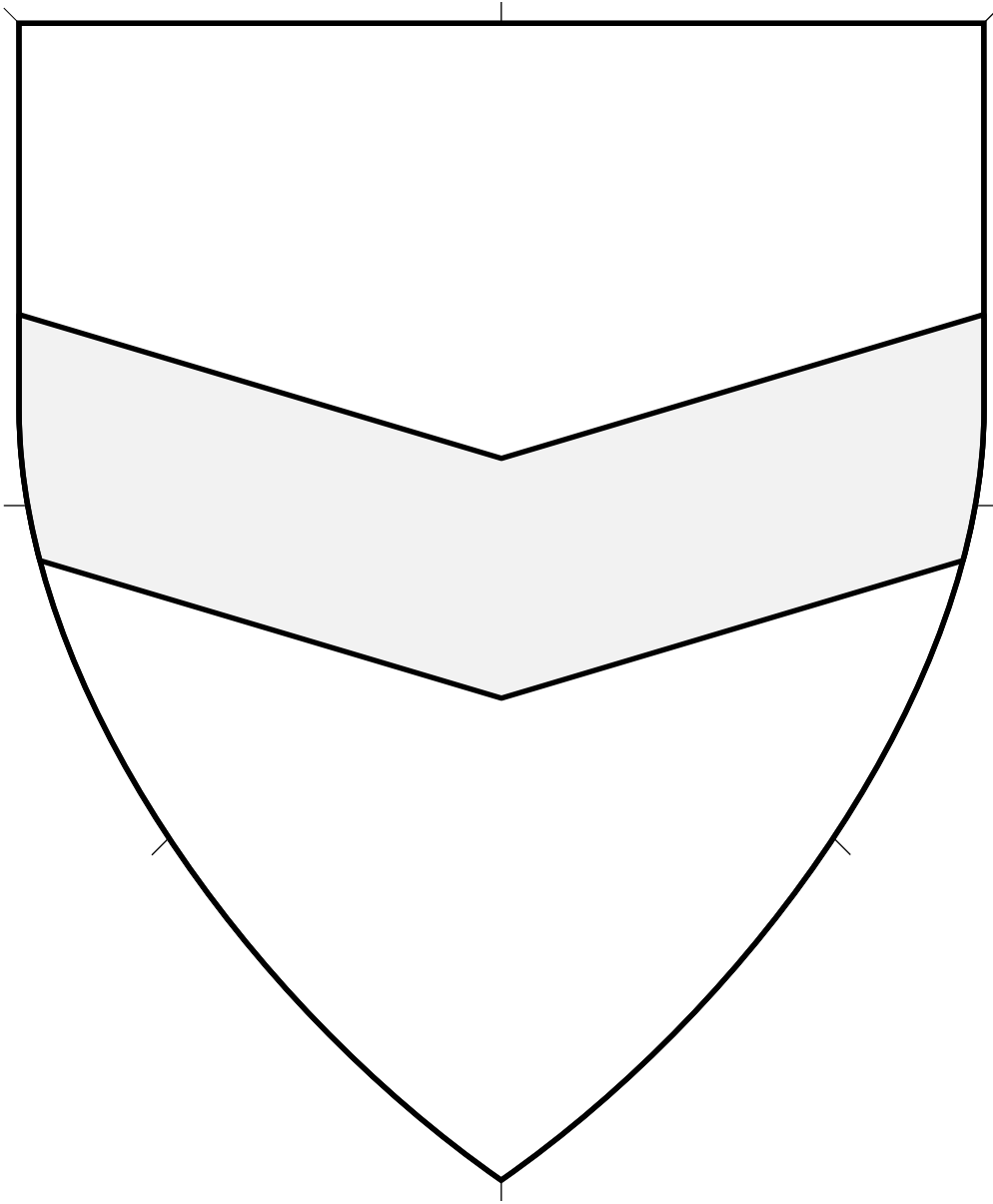

Central ordinary. Must issue from sides of device. Must be centered on the fess line, except if shifted up or down to accommodate secondary charges. Angle may be narrower or wider than 90°. The thickness of each arm is typically between a third to a fifth of the width of the device.

Chevron Inverted (5) 4.275

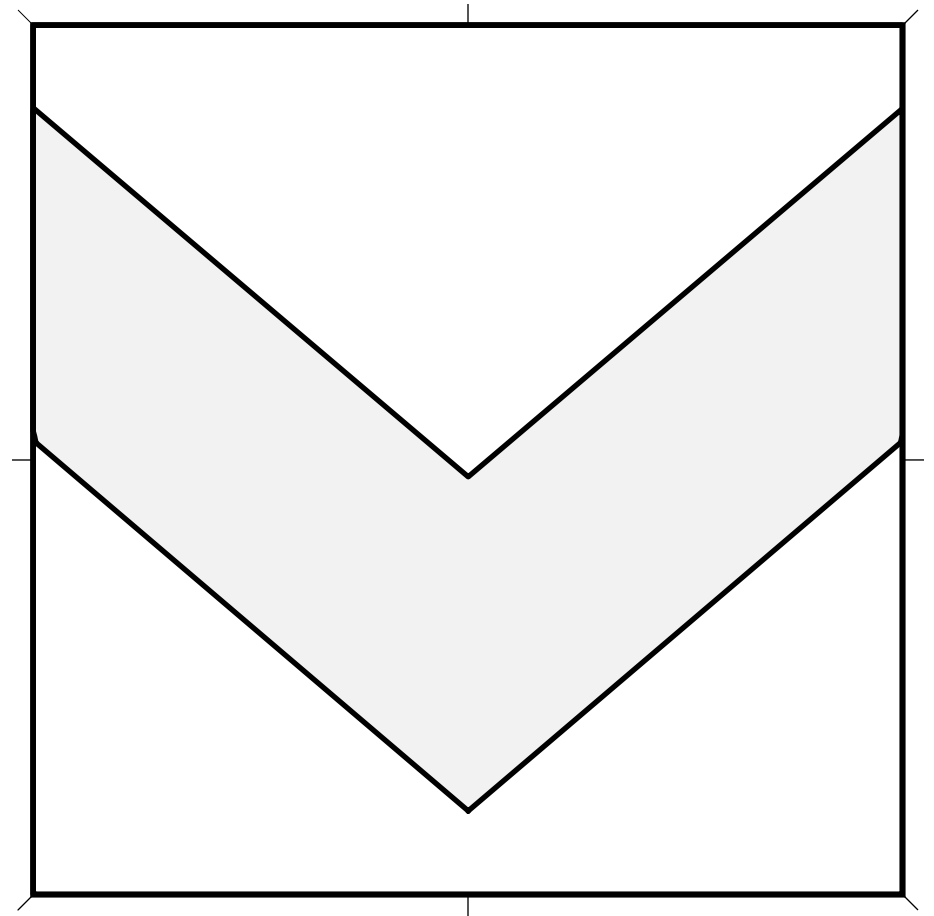
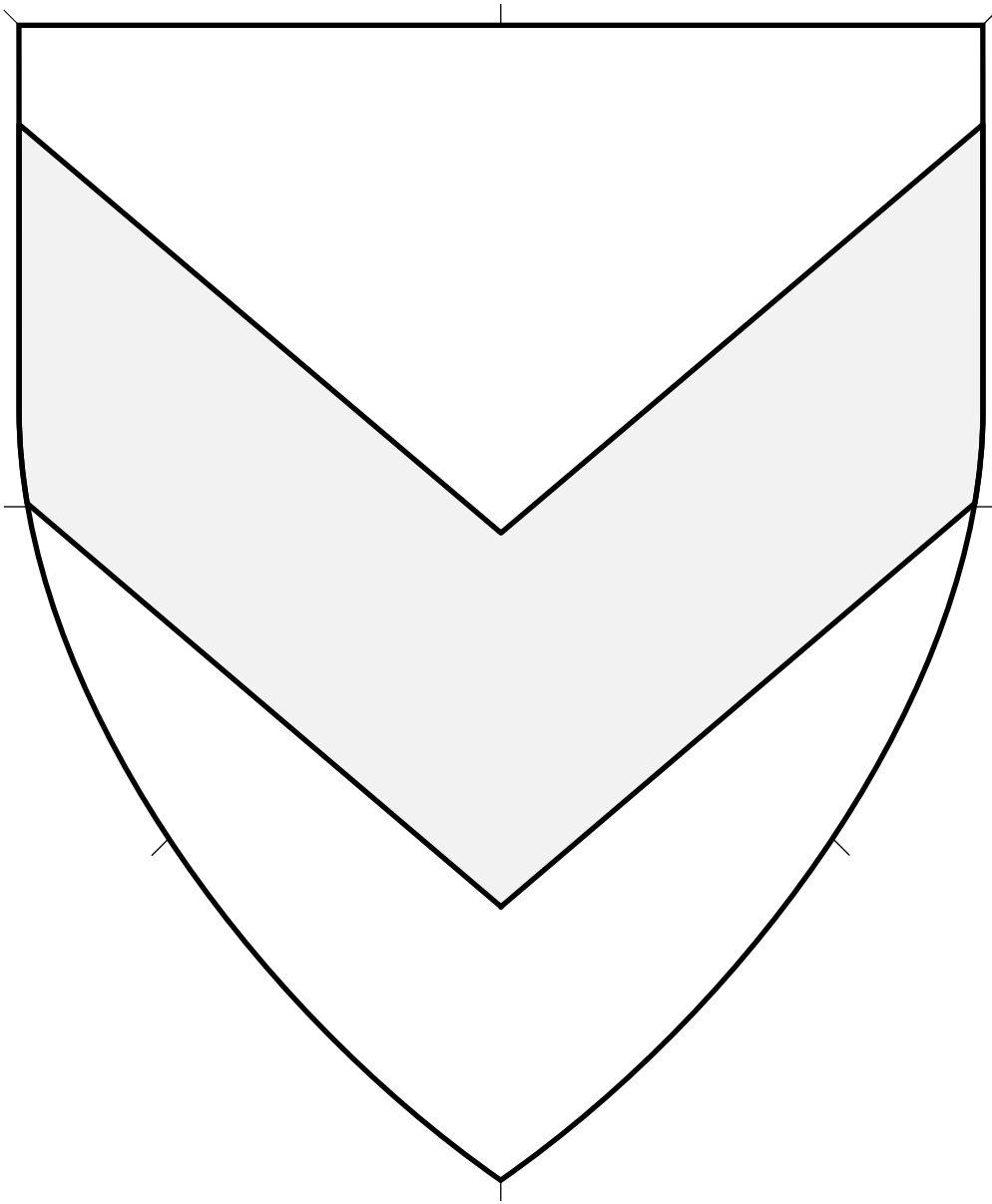

Central ordinary.

Source: Viking Answer Lady SVG Images For Heraldry.
Artist: Gunnvôr silfrahárr. Adapted by Mathghamhain Ua Ruadháin.

Chevron Inverted (6) 4.276

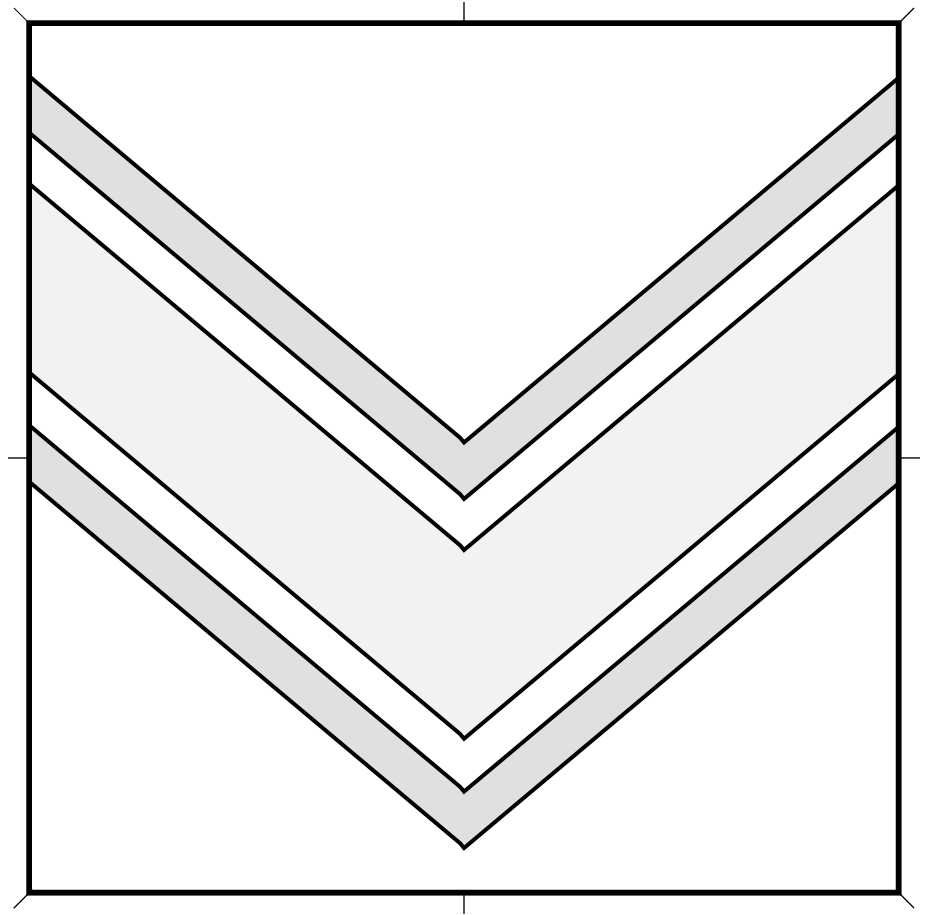
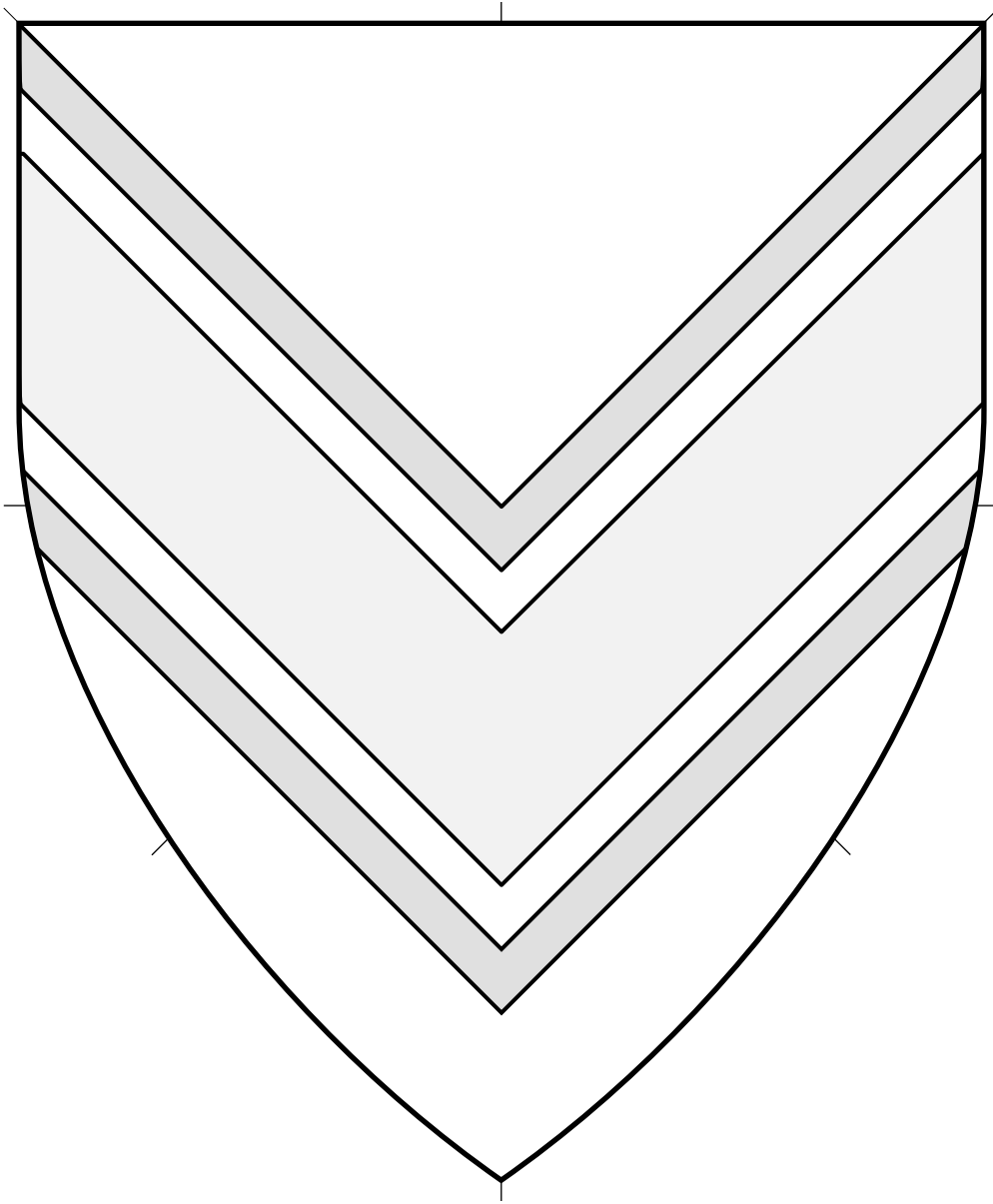

Central ordinary.

Chevron Inverted Cotised (1) 4.277

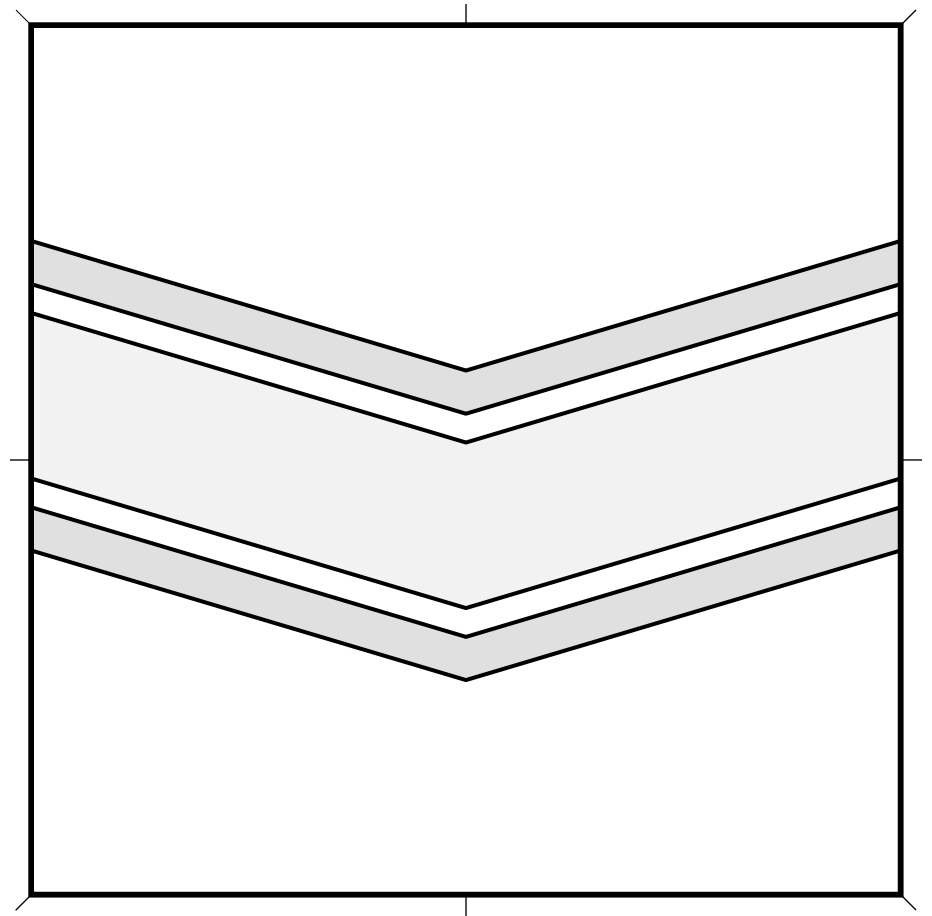
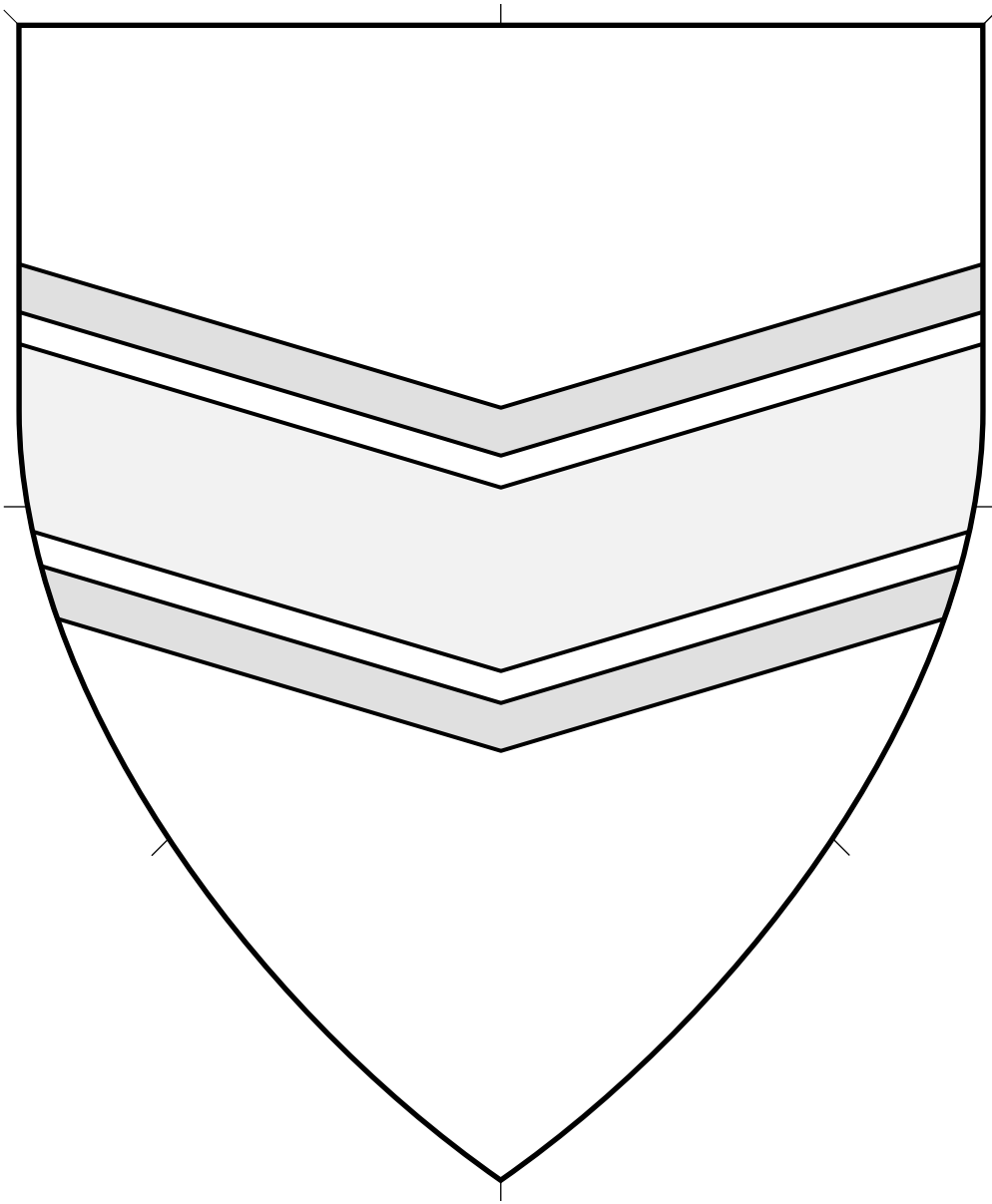

Central ordinary.

Chevron Inverted Cotised (2) 4.278

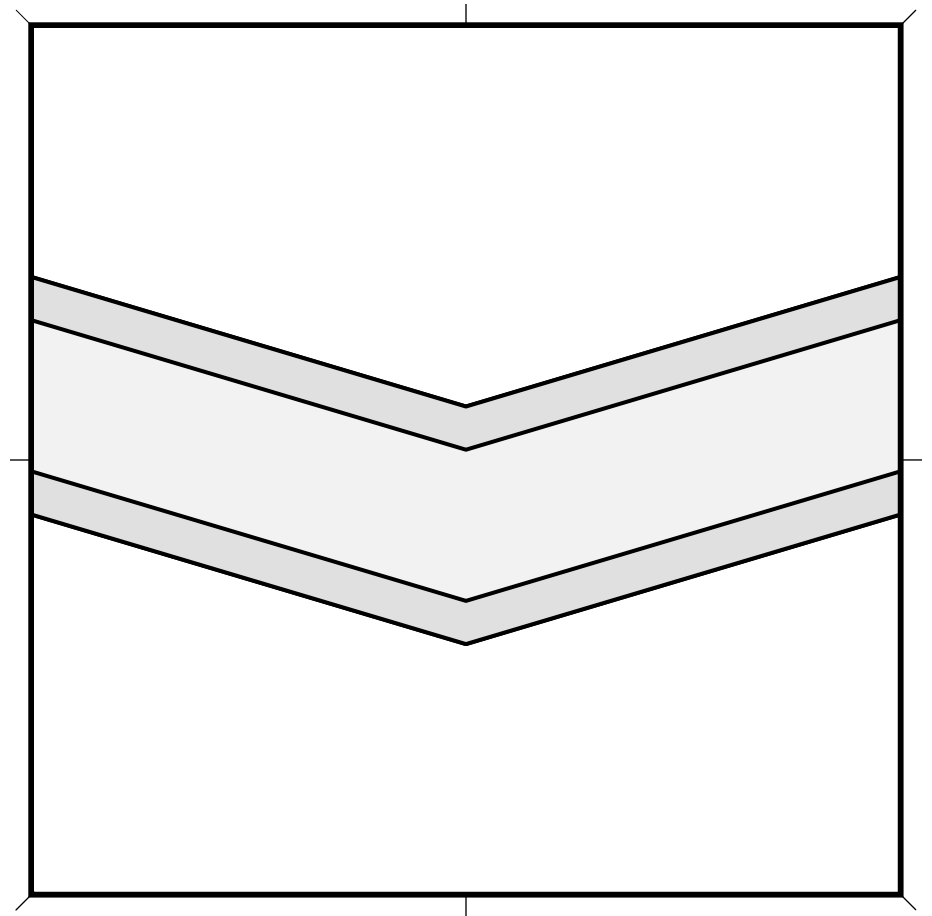
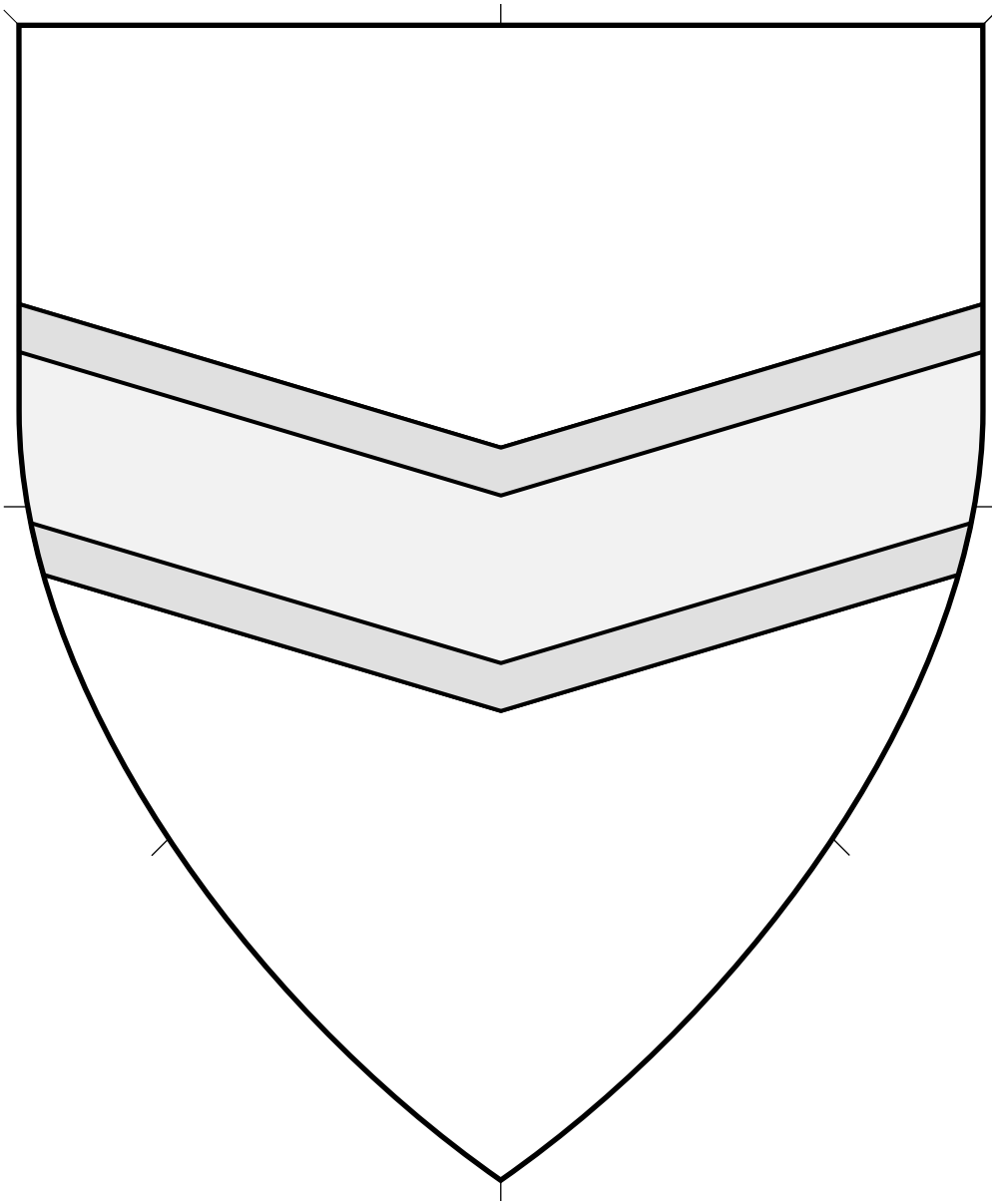

Central ordinary.

Chevron Inverted Fimbriated (1) 4.279

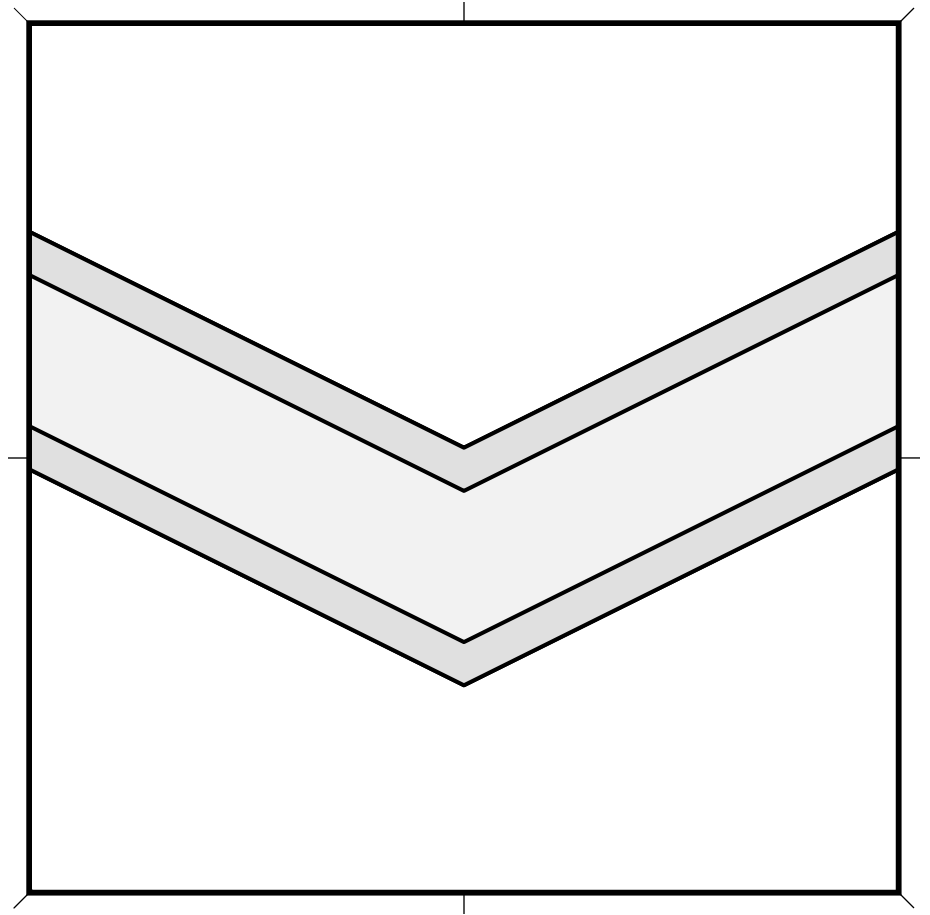
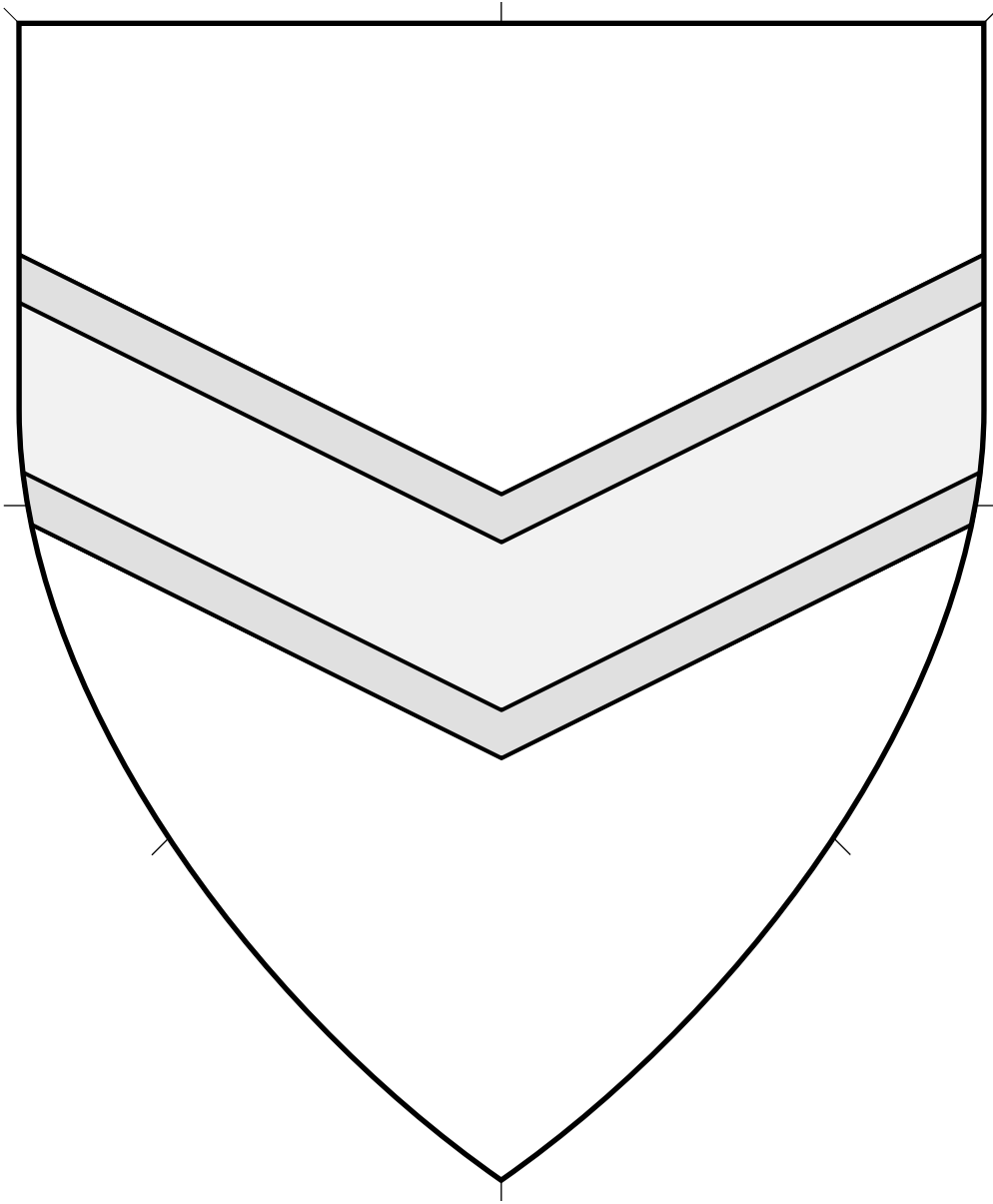

Central ordinary.

Chevron Inverted Fimbriated (2) 4.280

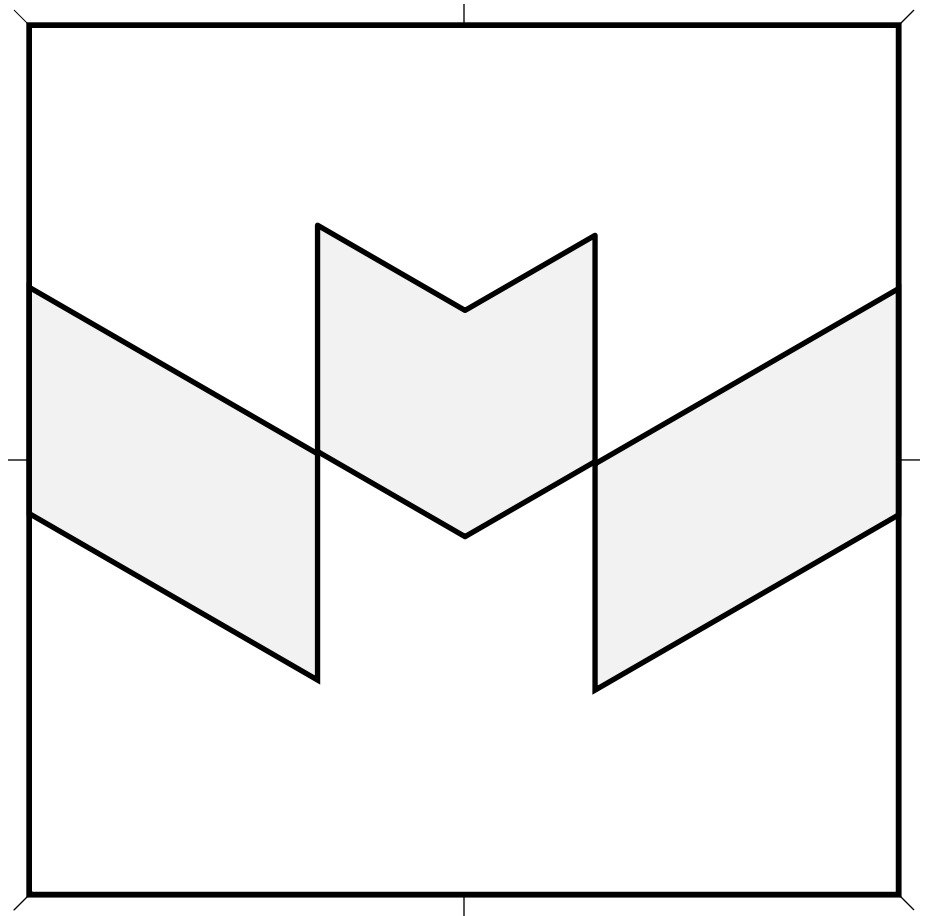
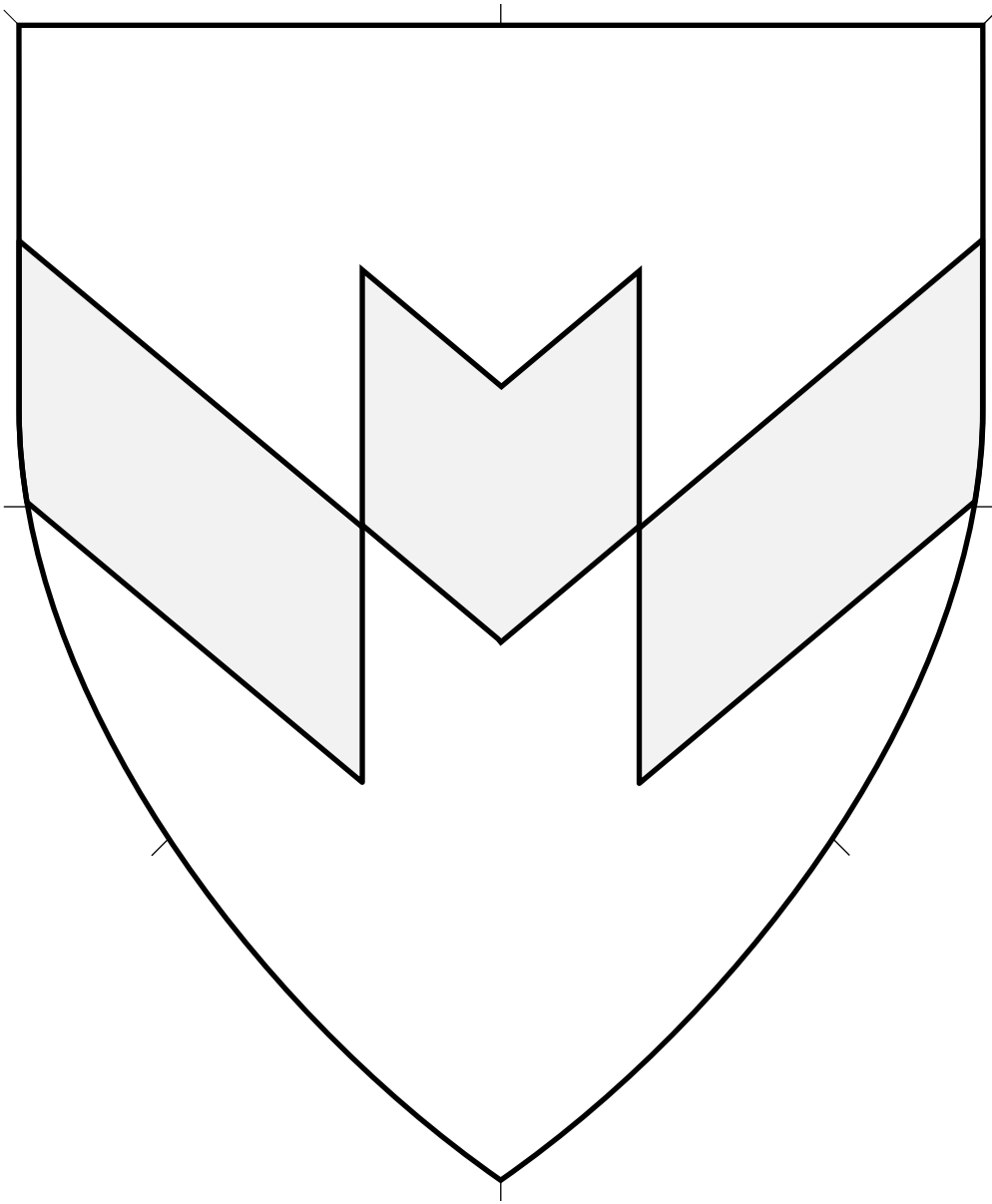

Central ordinary.

Chevron Fracted and Inverted 4.281

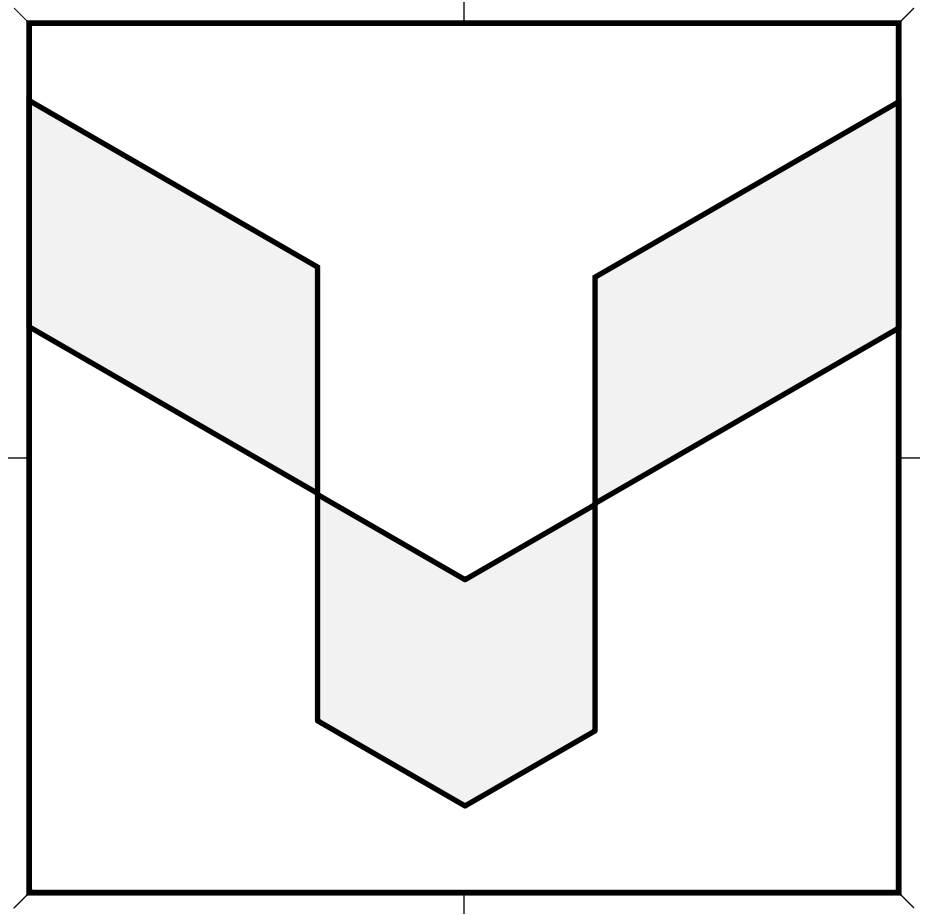
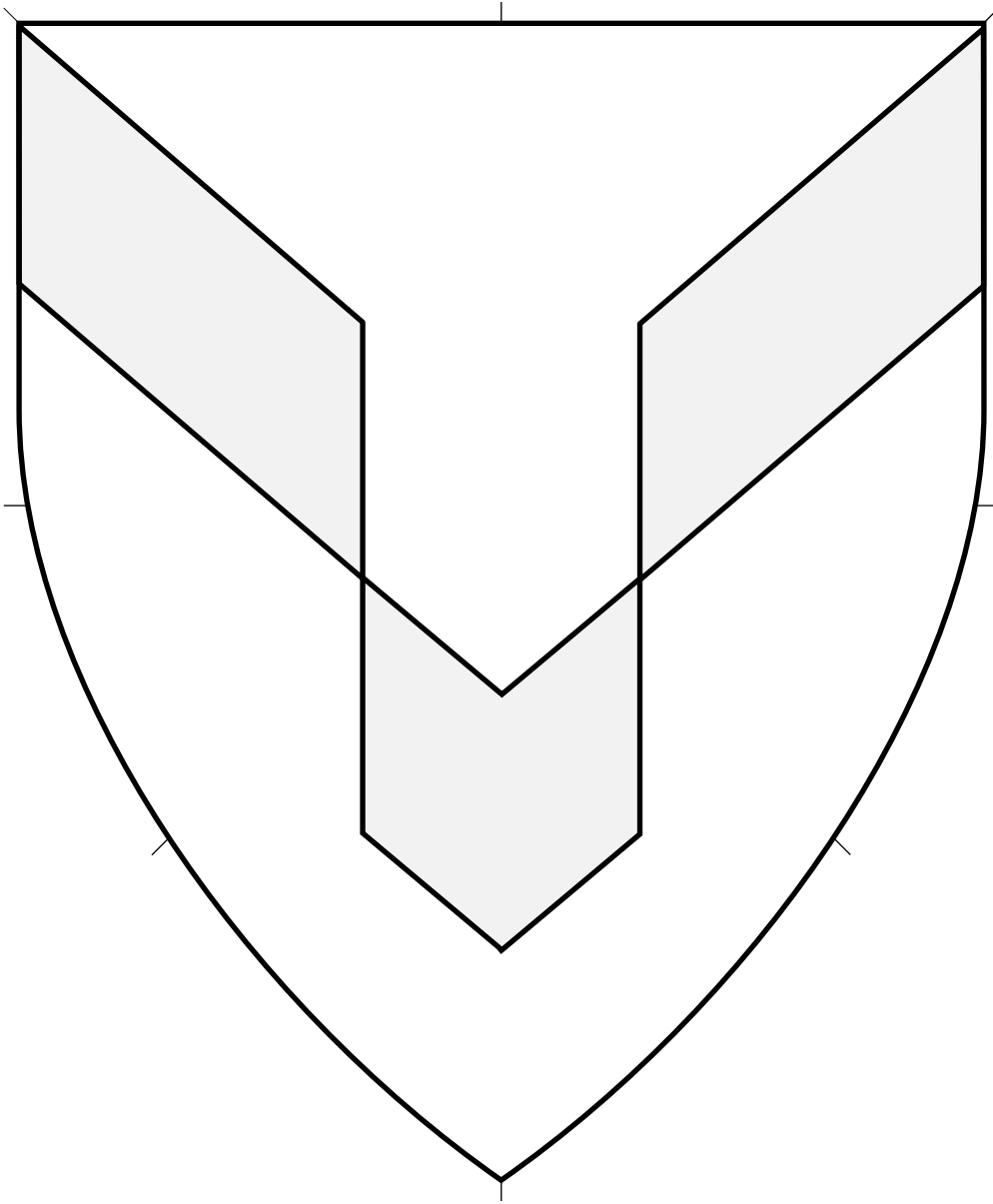

Central ordinary.

Chevron Inverted Rompu (1) 4.282

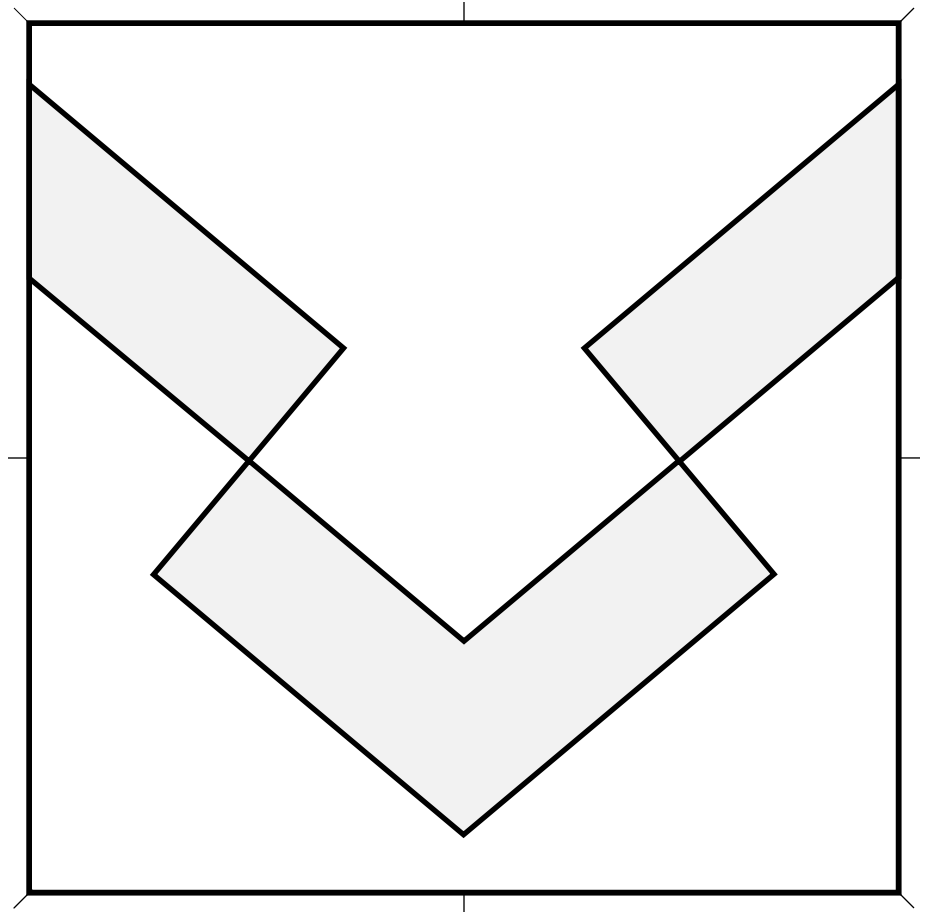
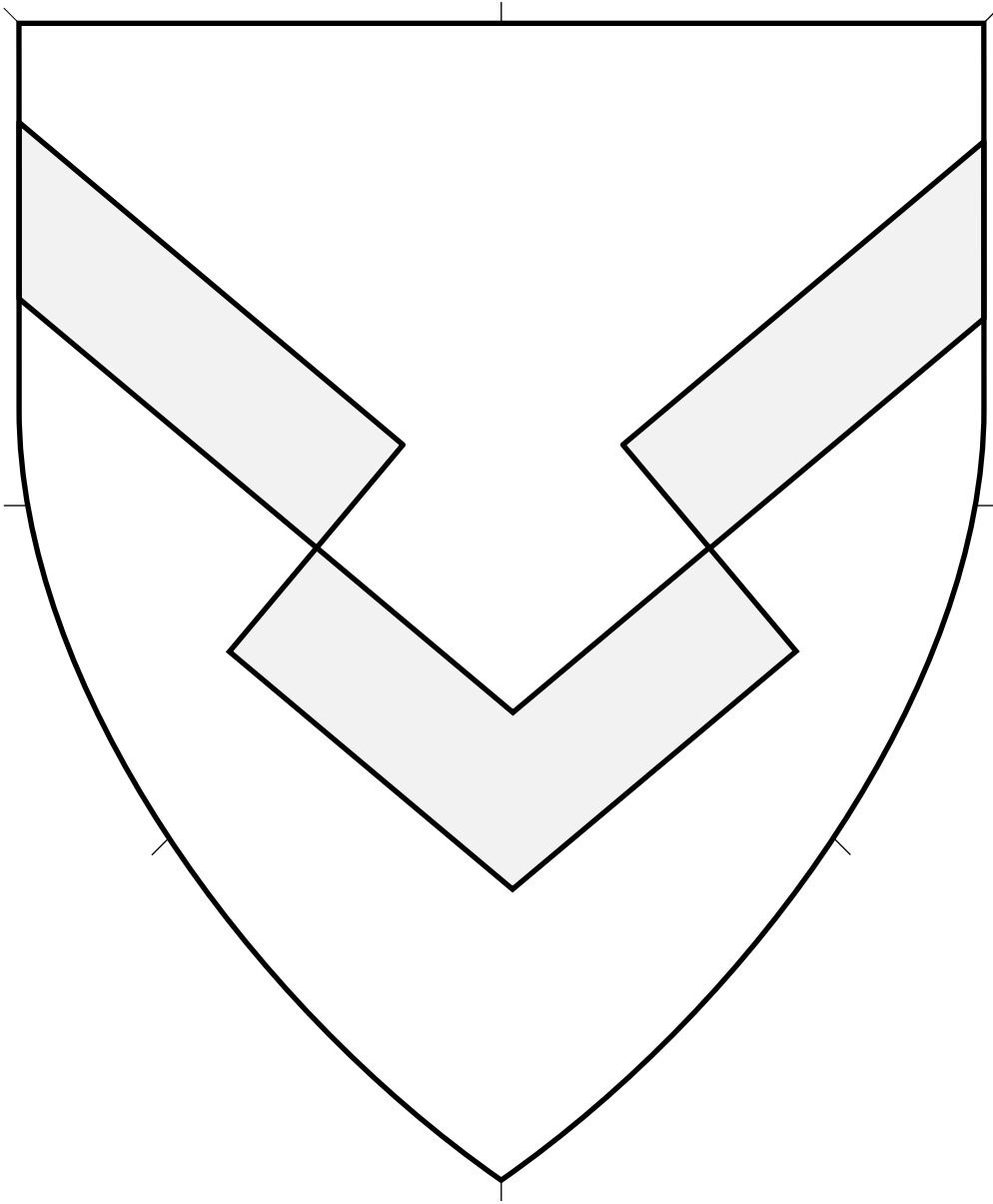

Central ordinary.

Chevron Inverted Rompu (2) 4.283

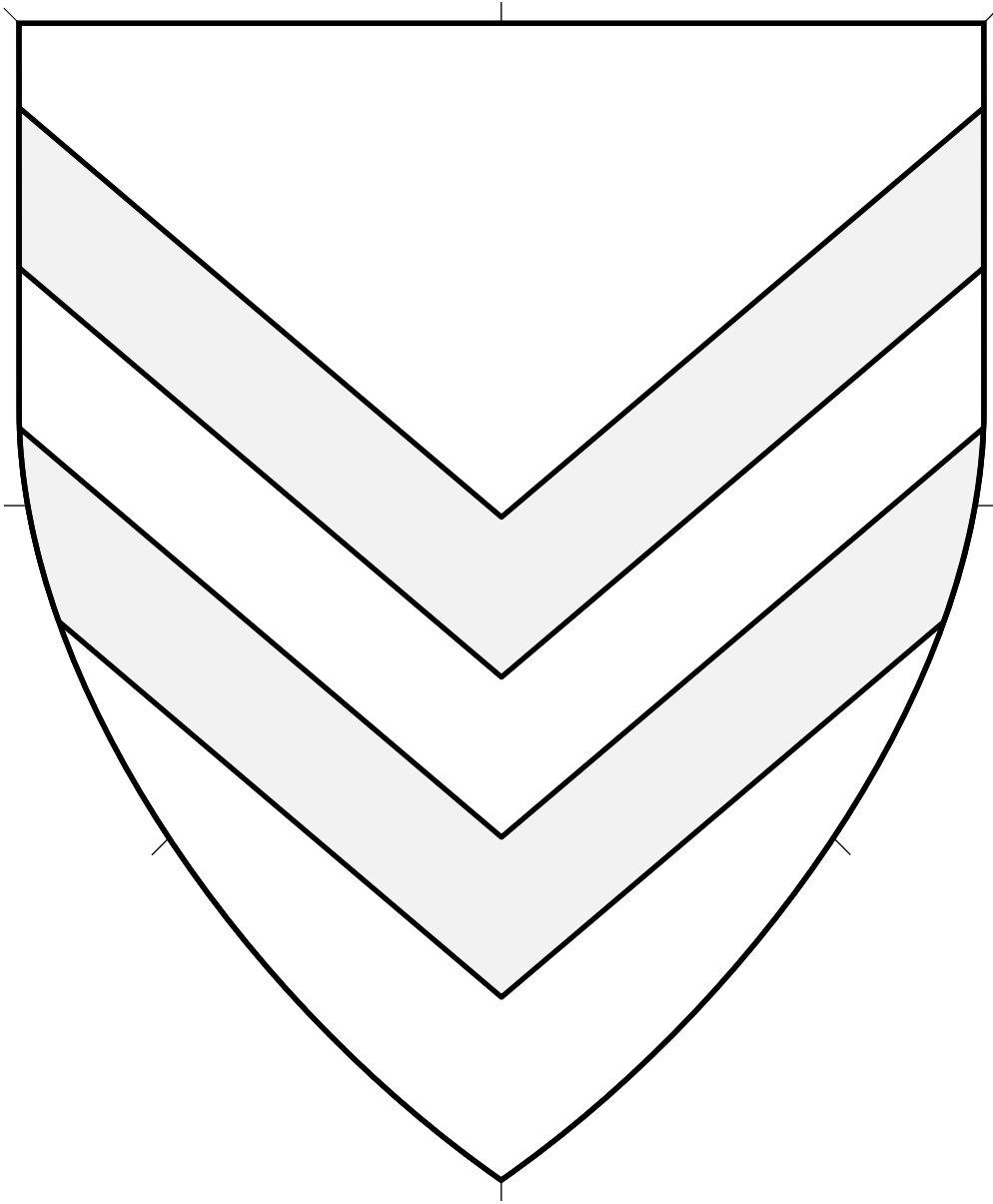

Central ordinary.

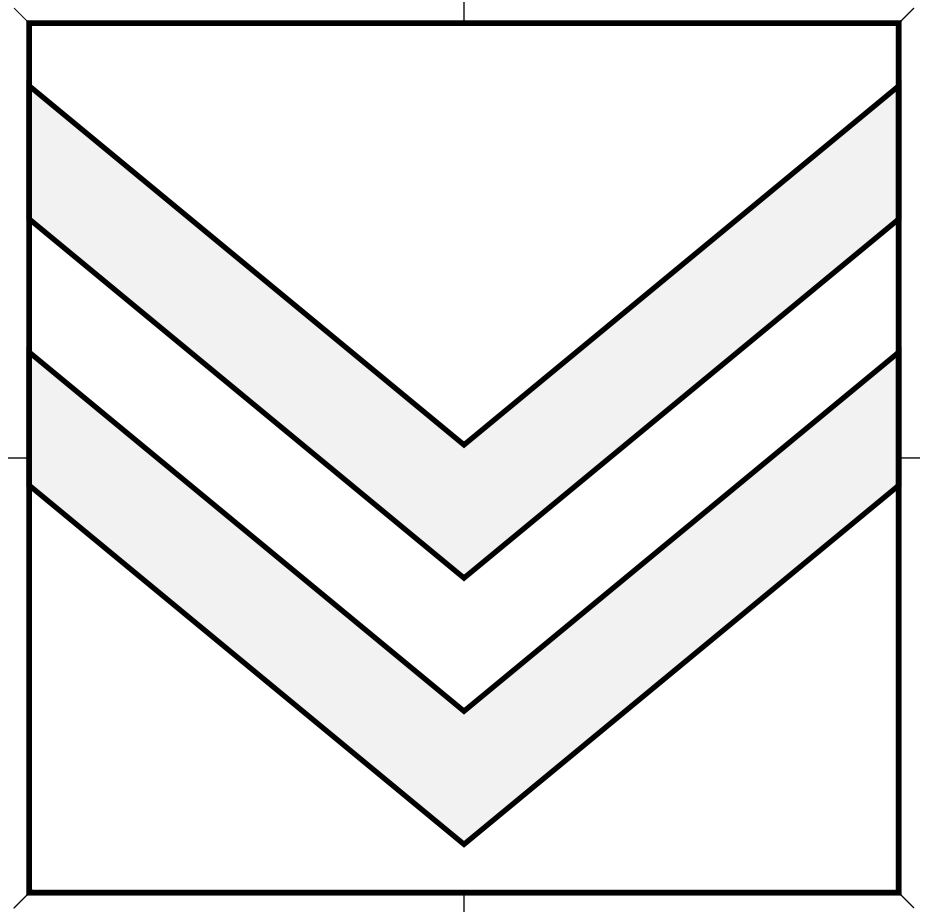

Chevronels Inverted, 2 4.284

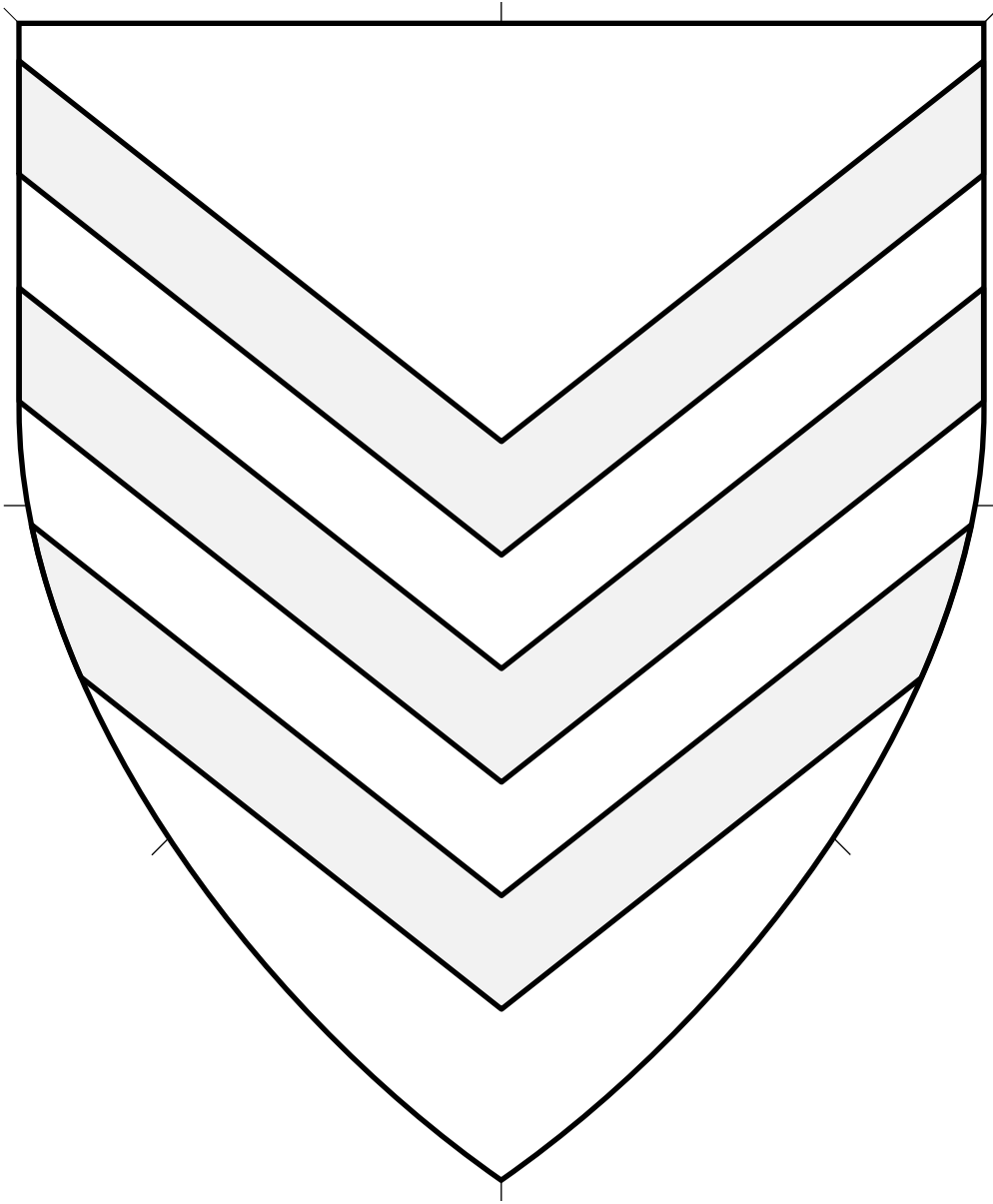

Central ordinary.

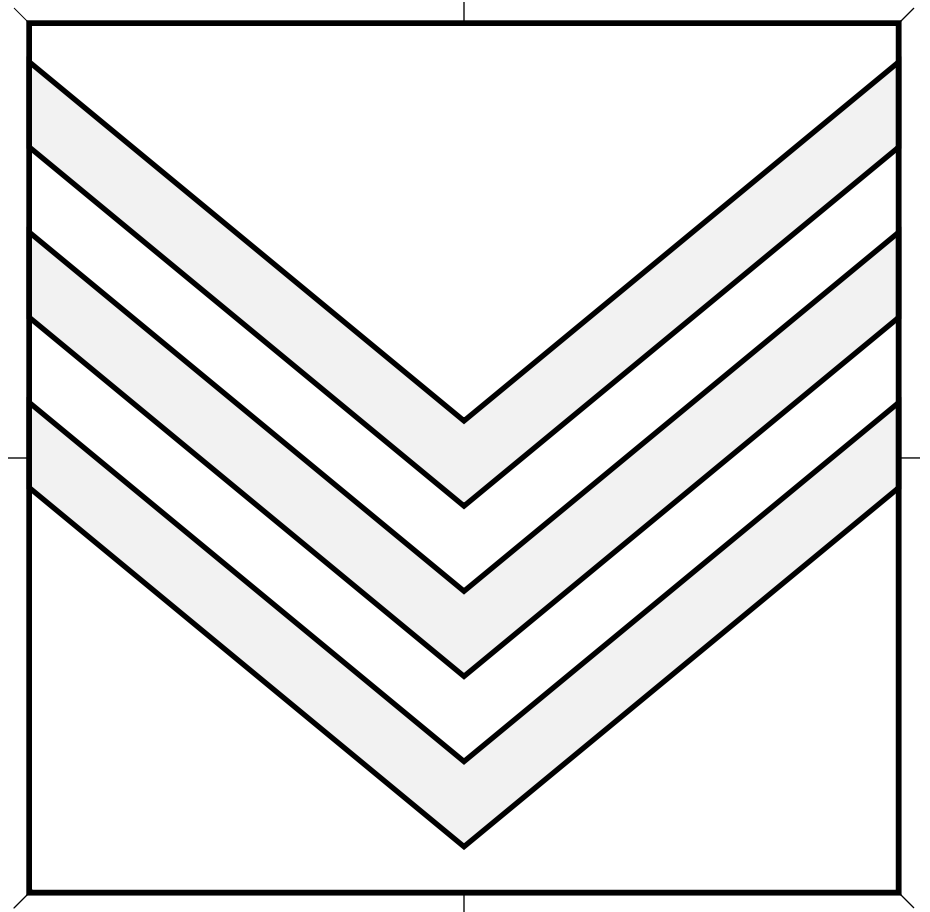

Chevronels Inverted, 3 4.285

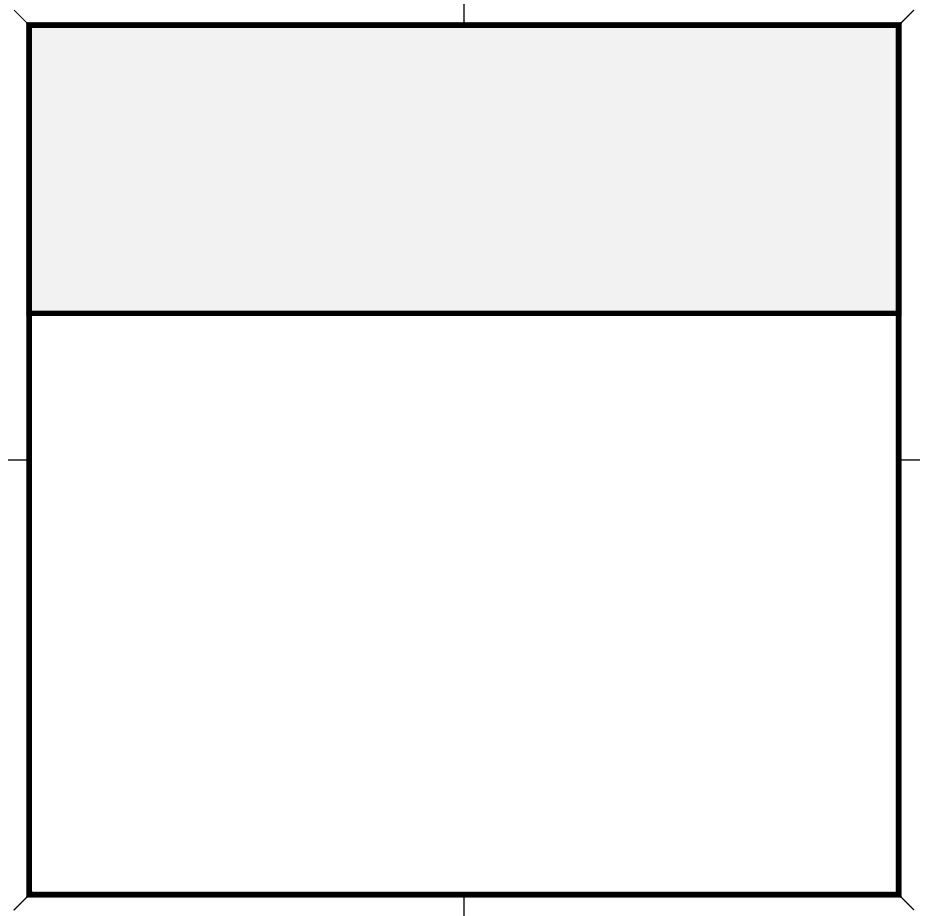
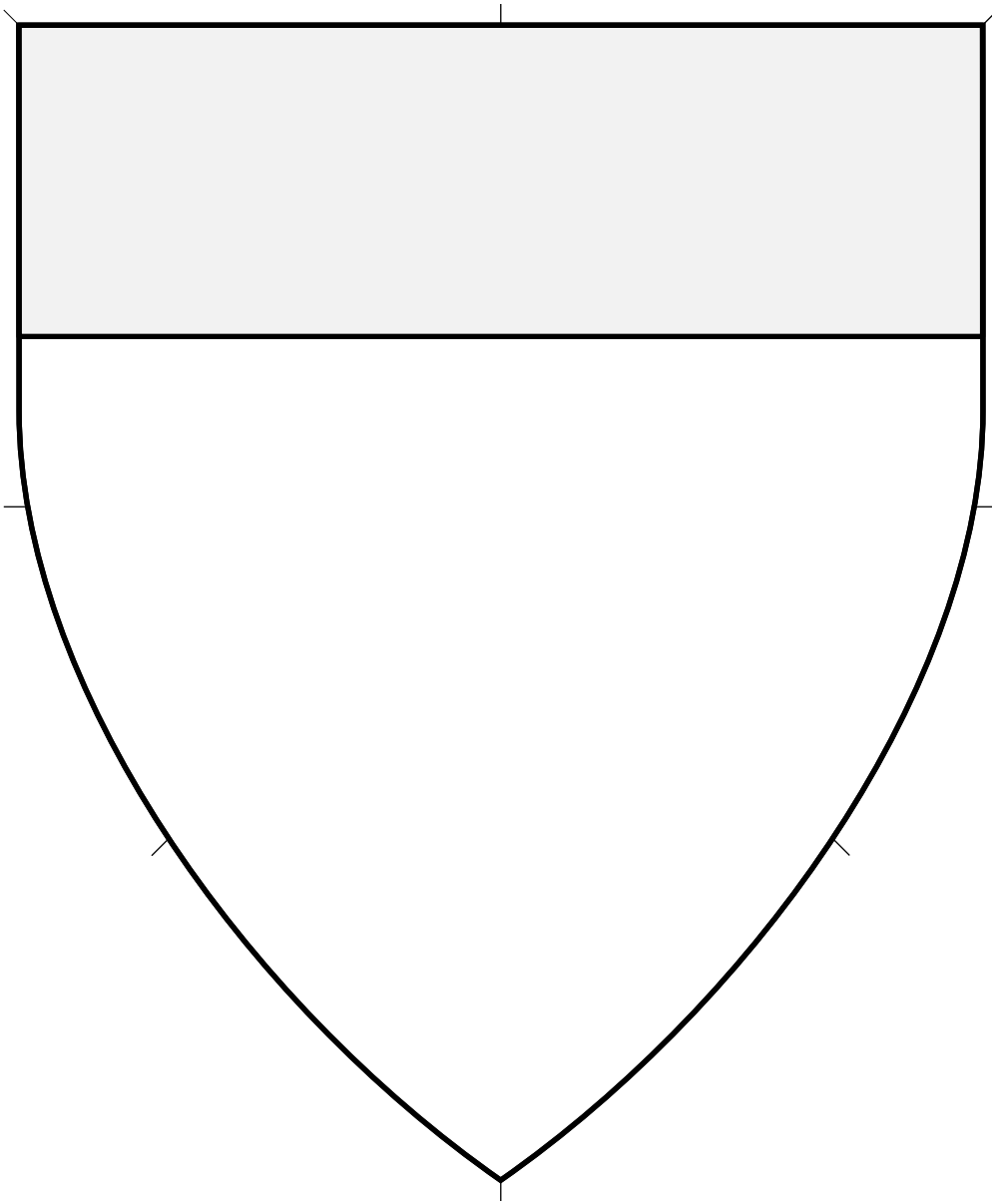

Peripheral ordinary. The height is typically a third of the width of the device or a bit narrower. This is a full-size chief.

Chief (1) 4.286

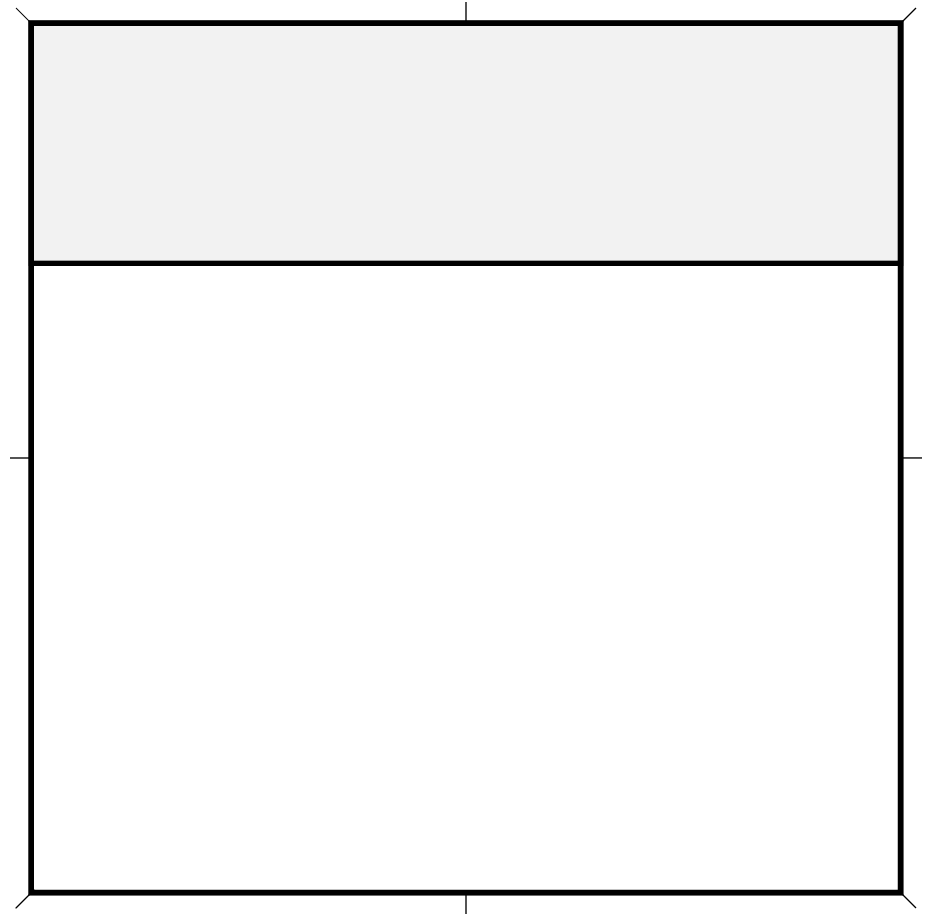
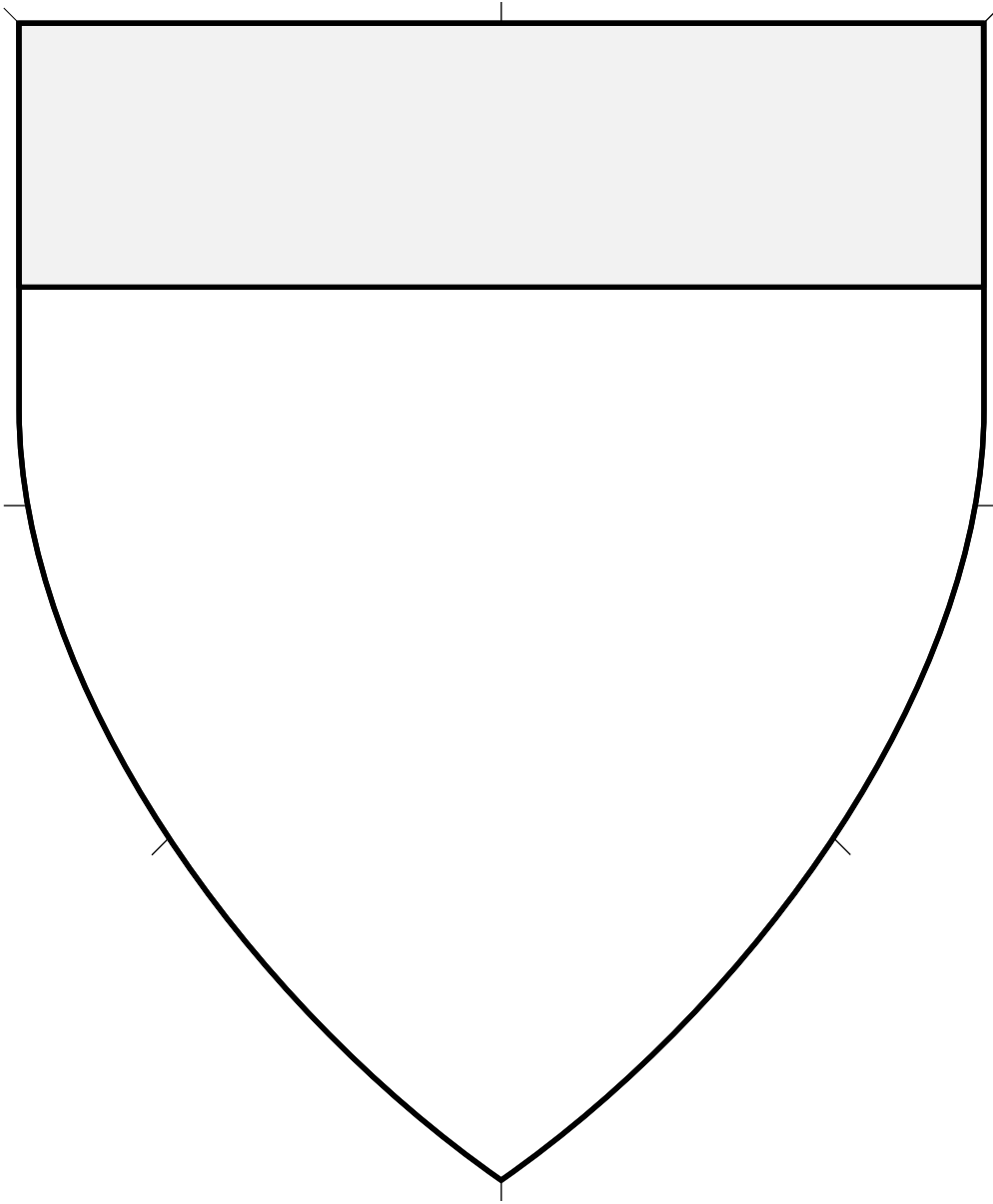

Peripheral ordinary. The height is typically a third of the width of the device or a bit narrower. This is a medium-size chief.

Chief (2) 4.287

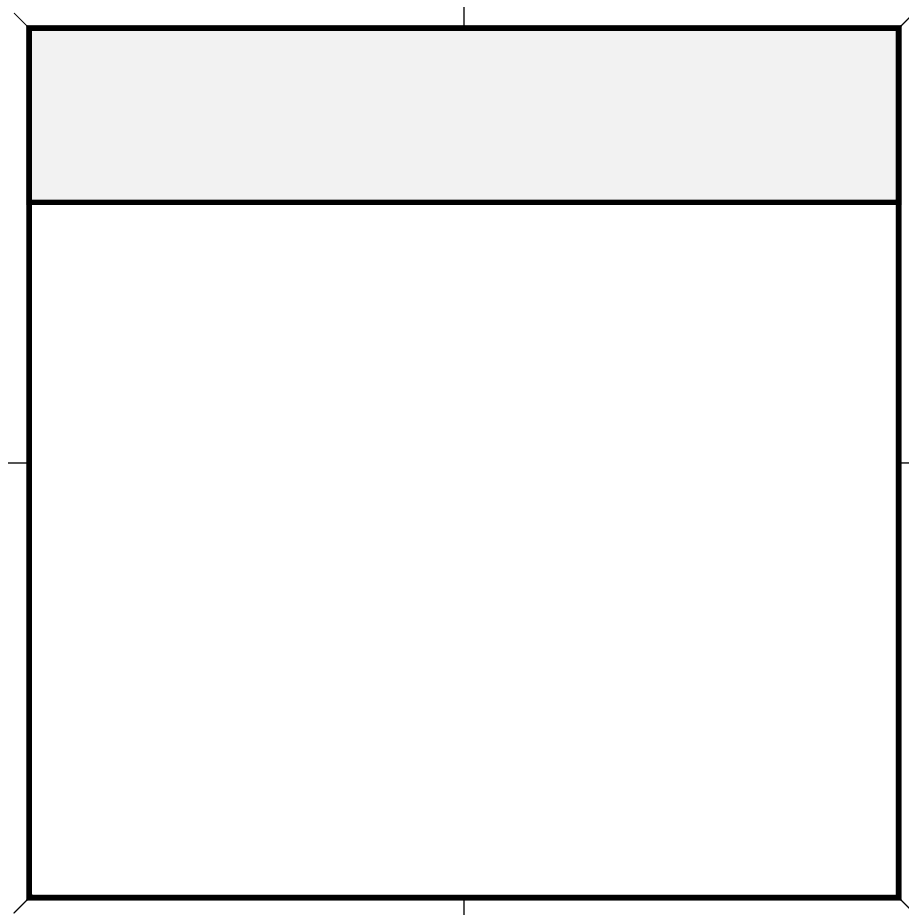
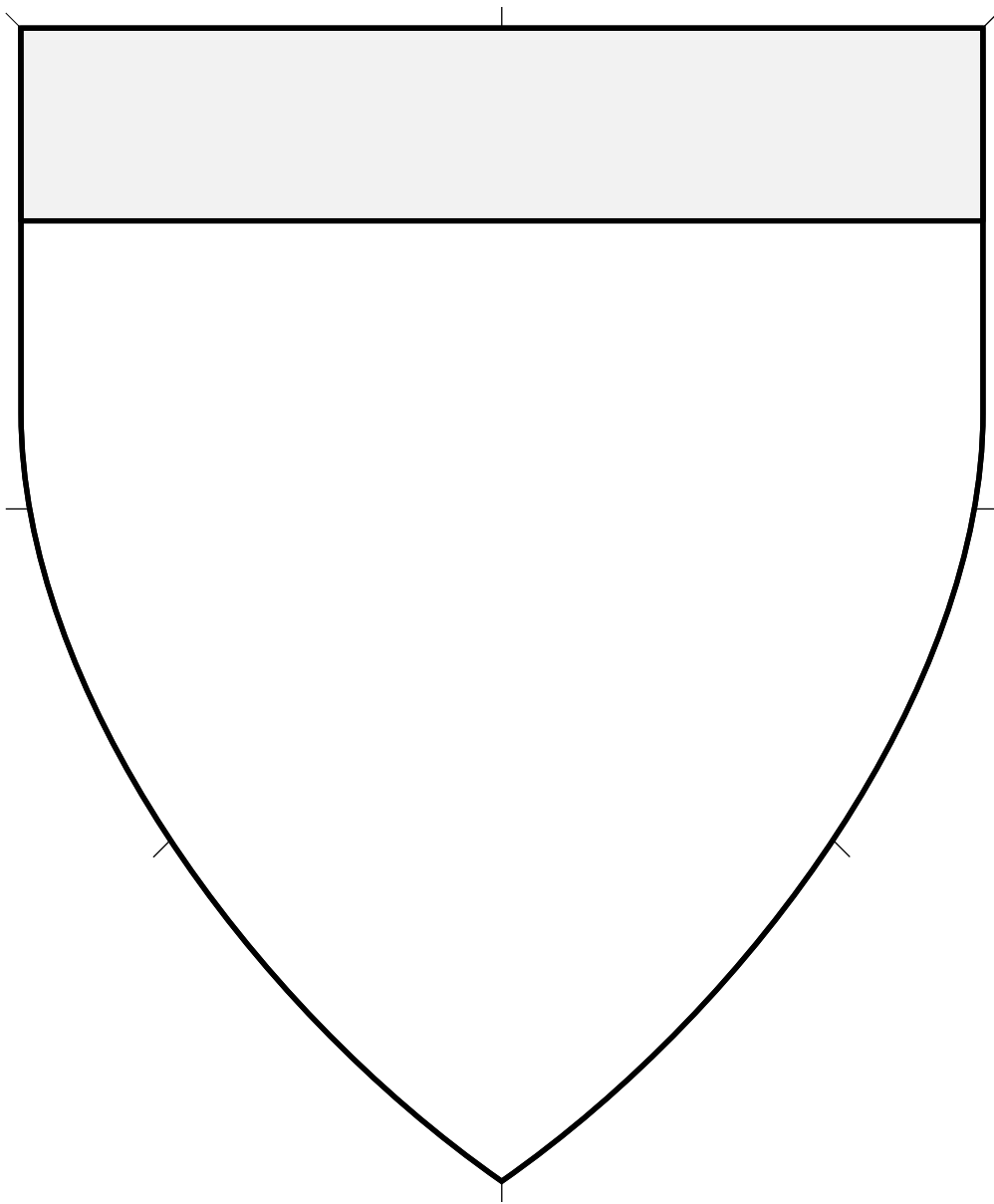

Peripheral ordinary. The height is typically a third of the width of the device or a bit narrower. This is a skinny chief.

Chief (3) 4.288

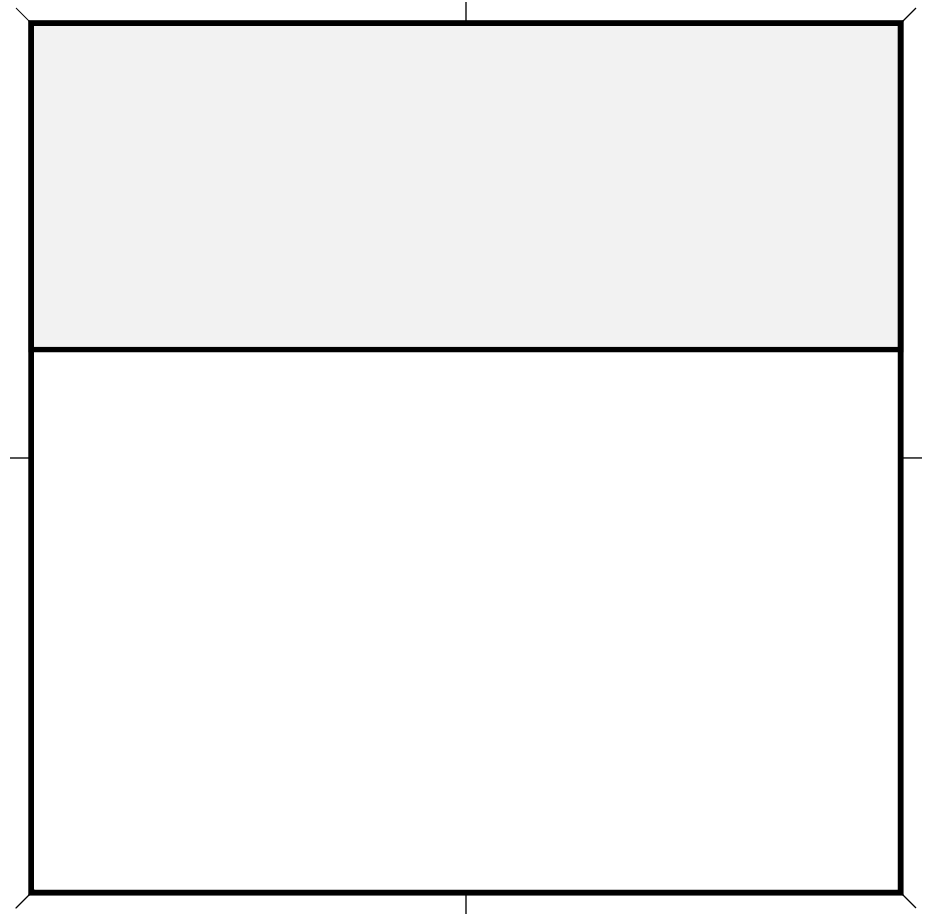
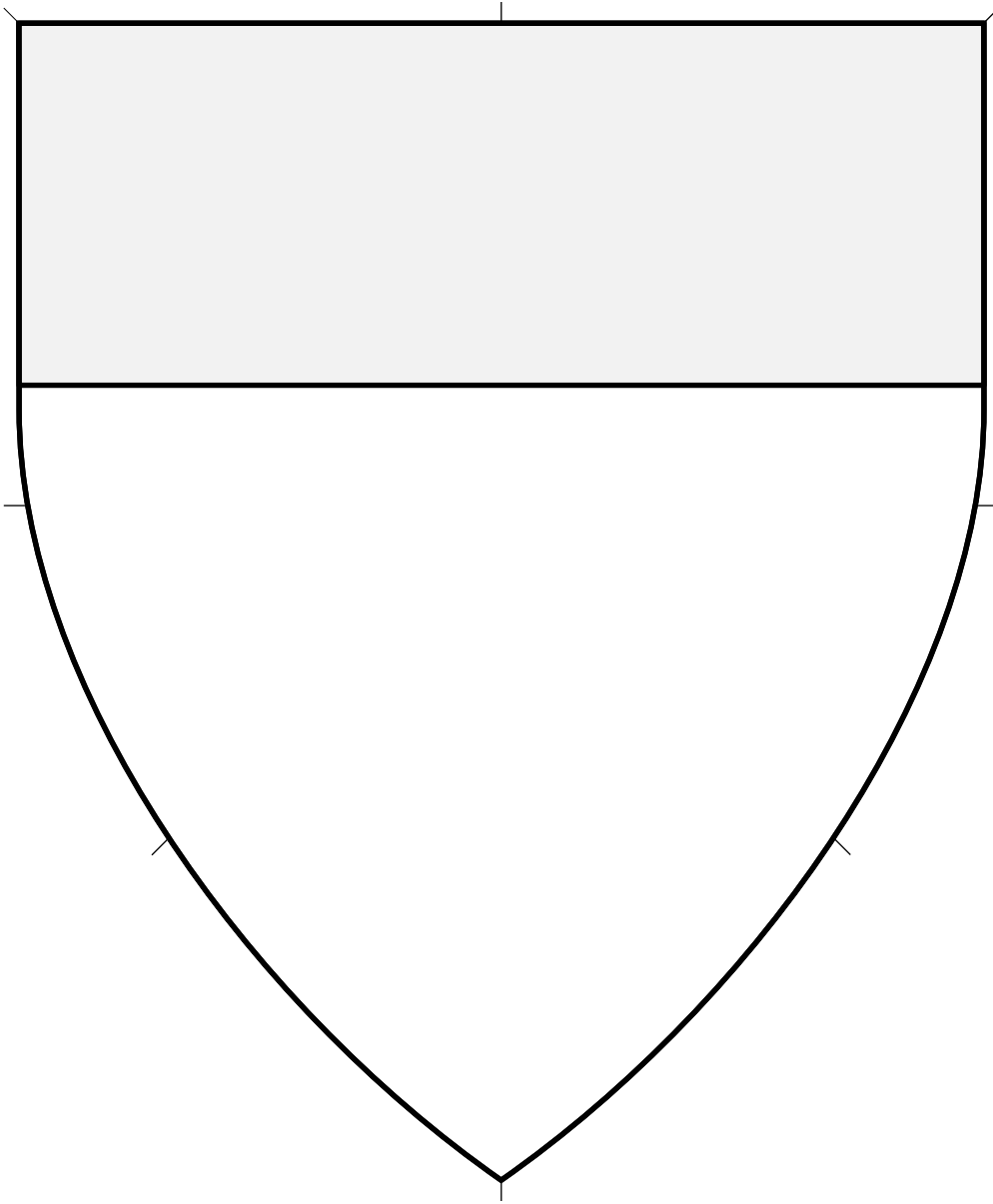

Peripheral ordinary. The height is typically a third of the width of the device or a bit narrower. This is an extra large chief.

Chief (4) 4.289

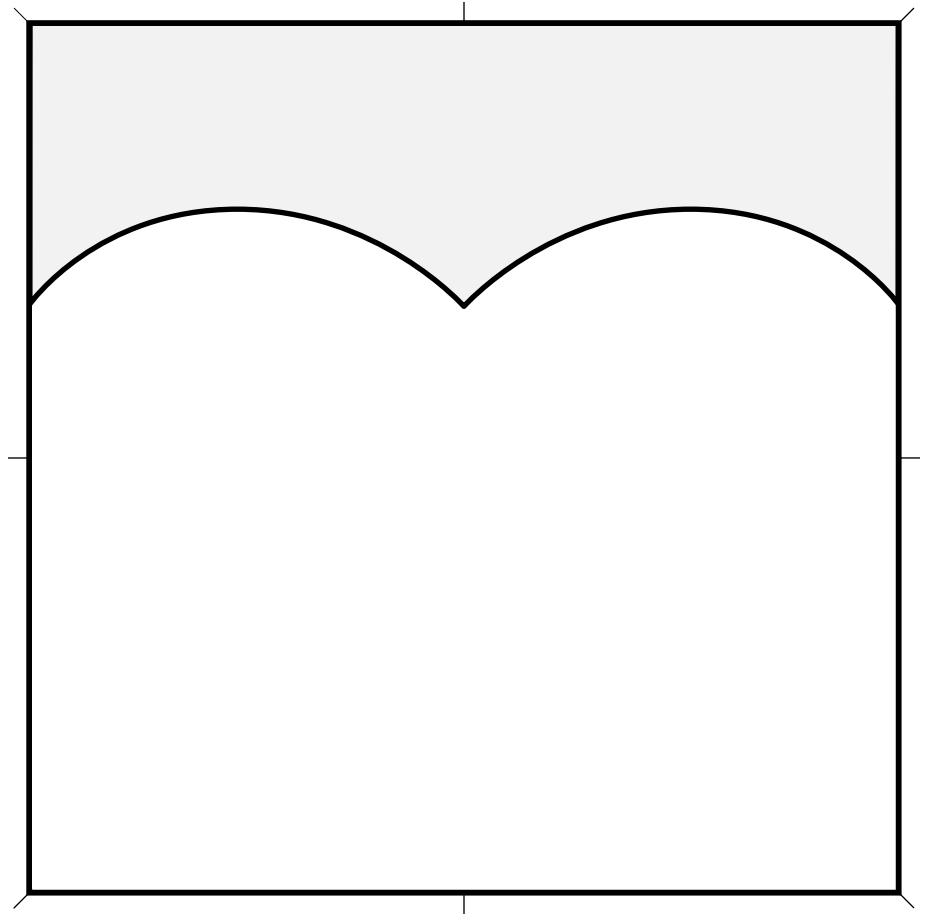
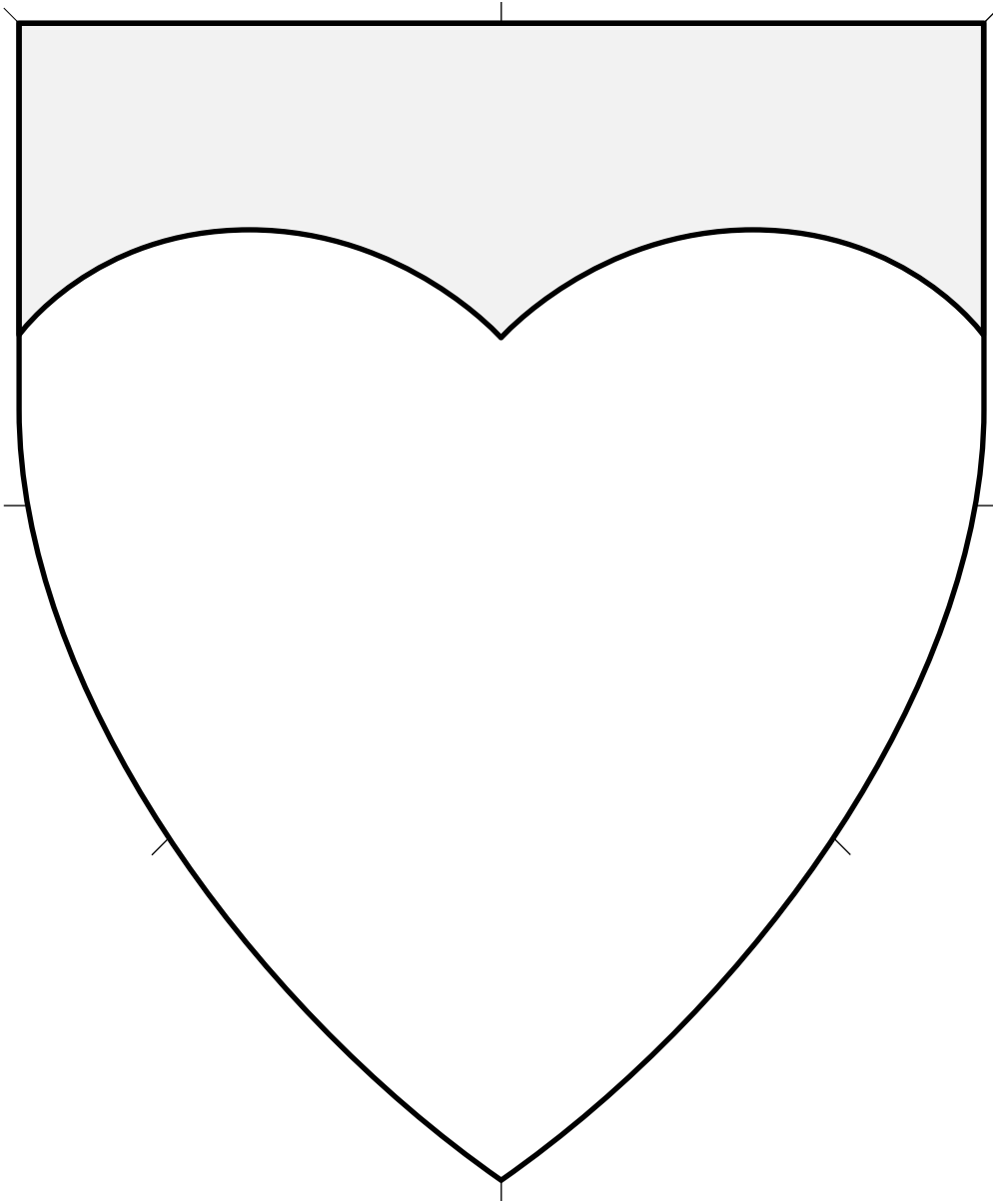

Peripheral ordinary.

Considered a step from core practice (SFCP) as of the Dec 2011 LoAR.

Chief Doubly Enarched 4.290

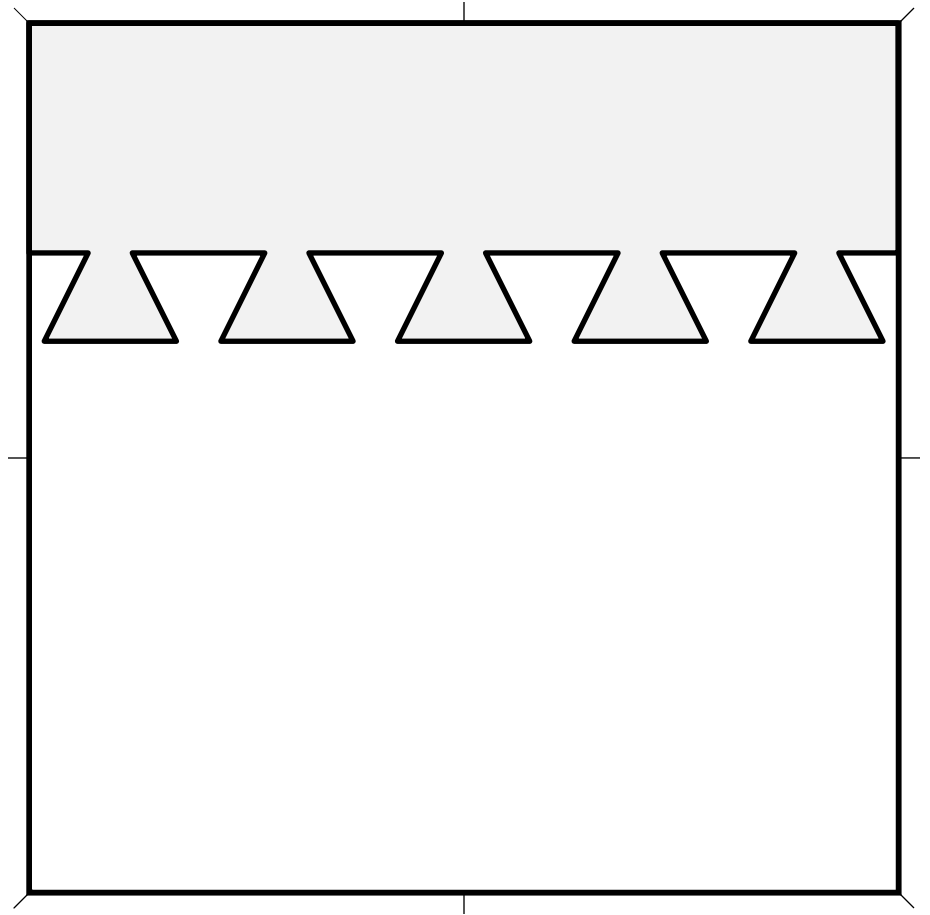
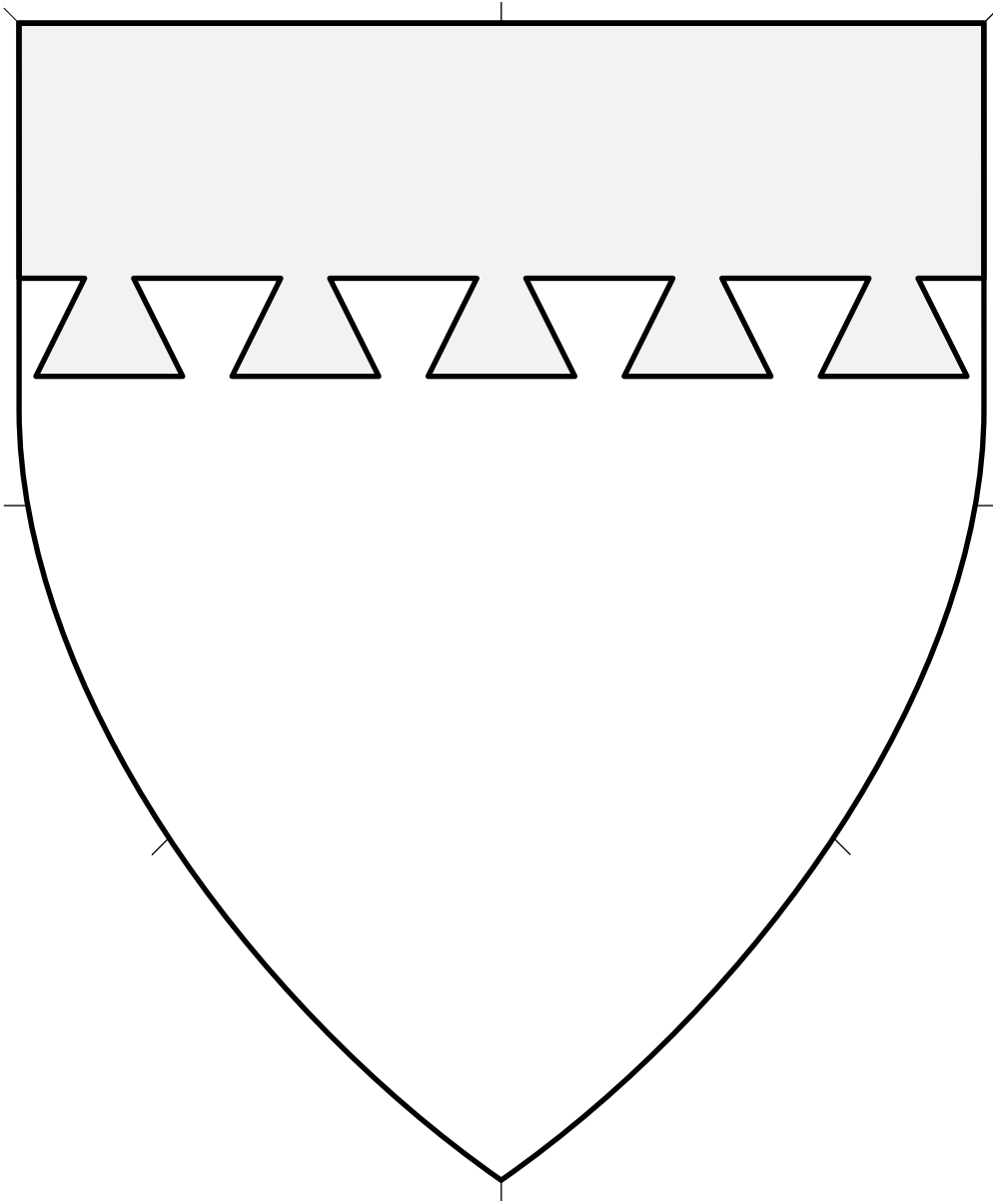

Peripheral ordinary.
Artist: Vémundr Syvursson.

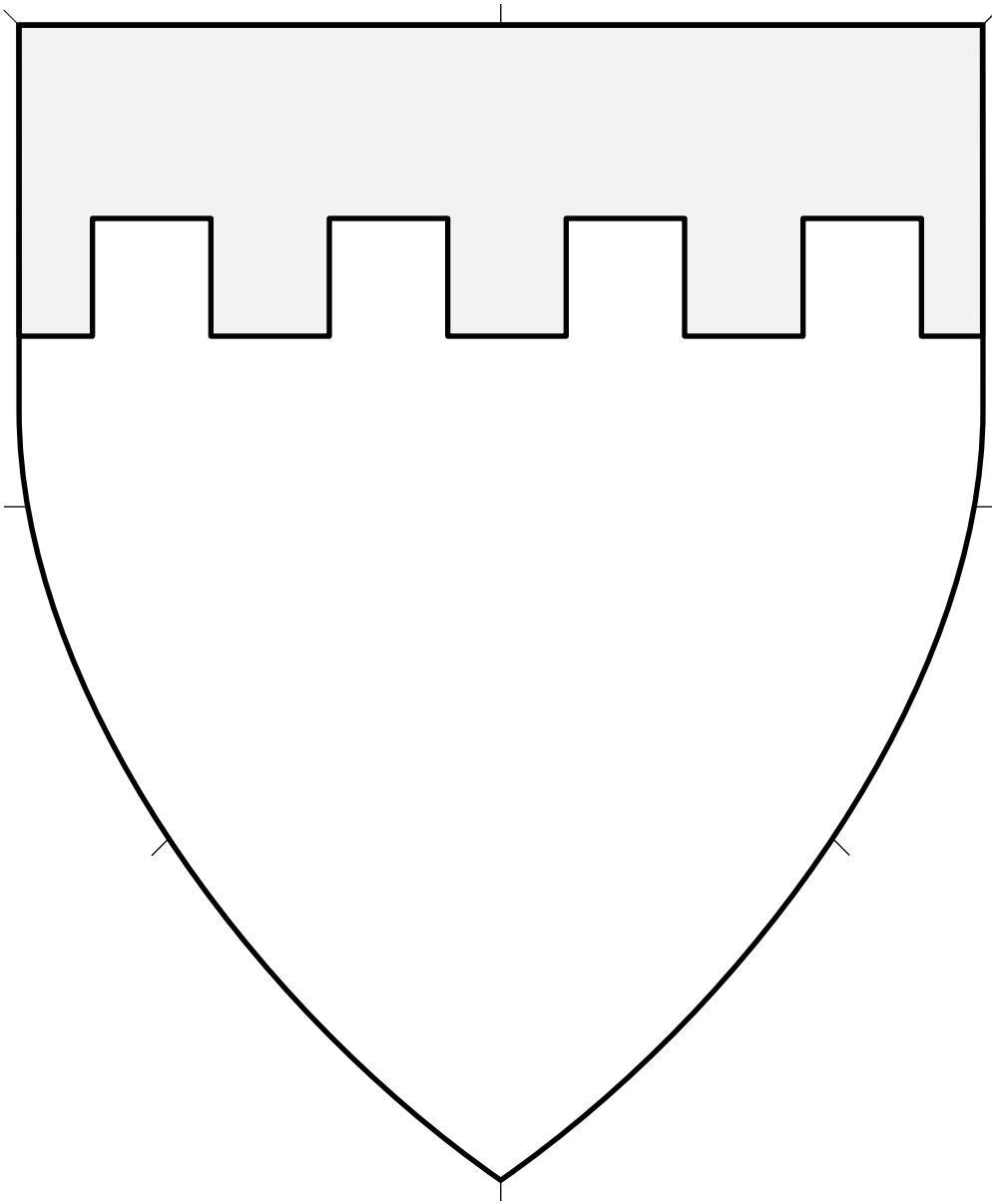

Peripheral ordinary.

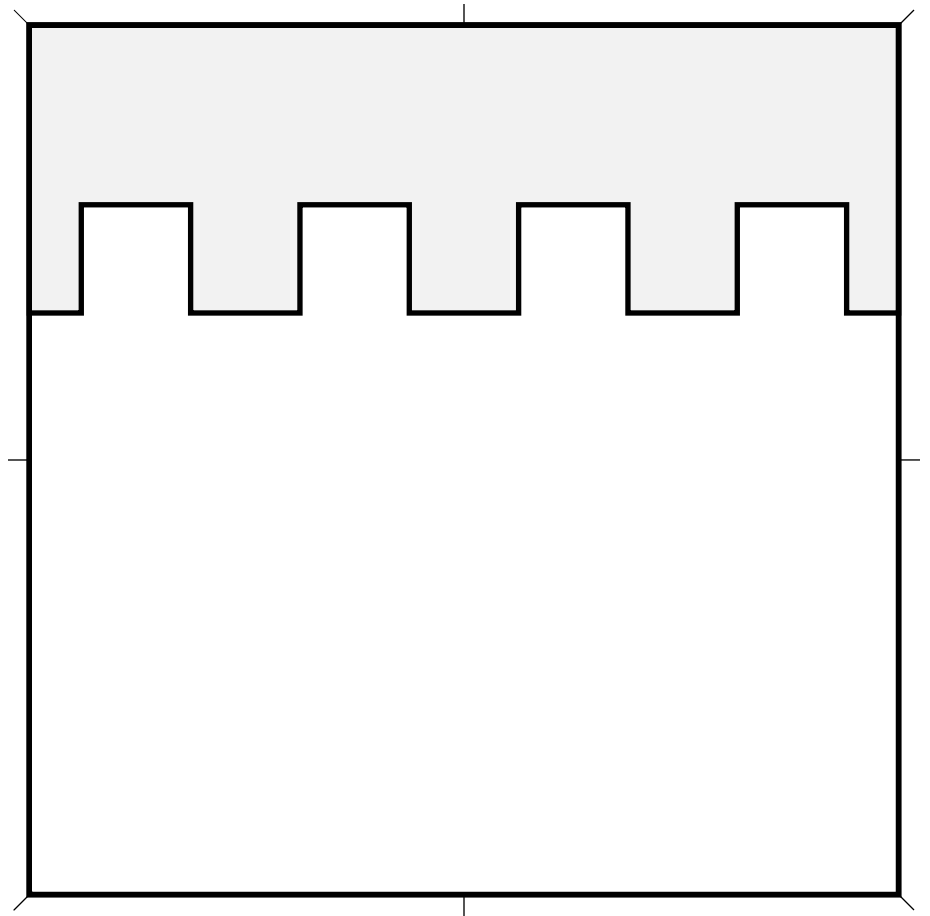

Chief Embattled (1) 4.292

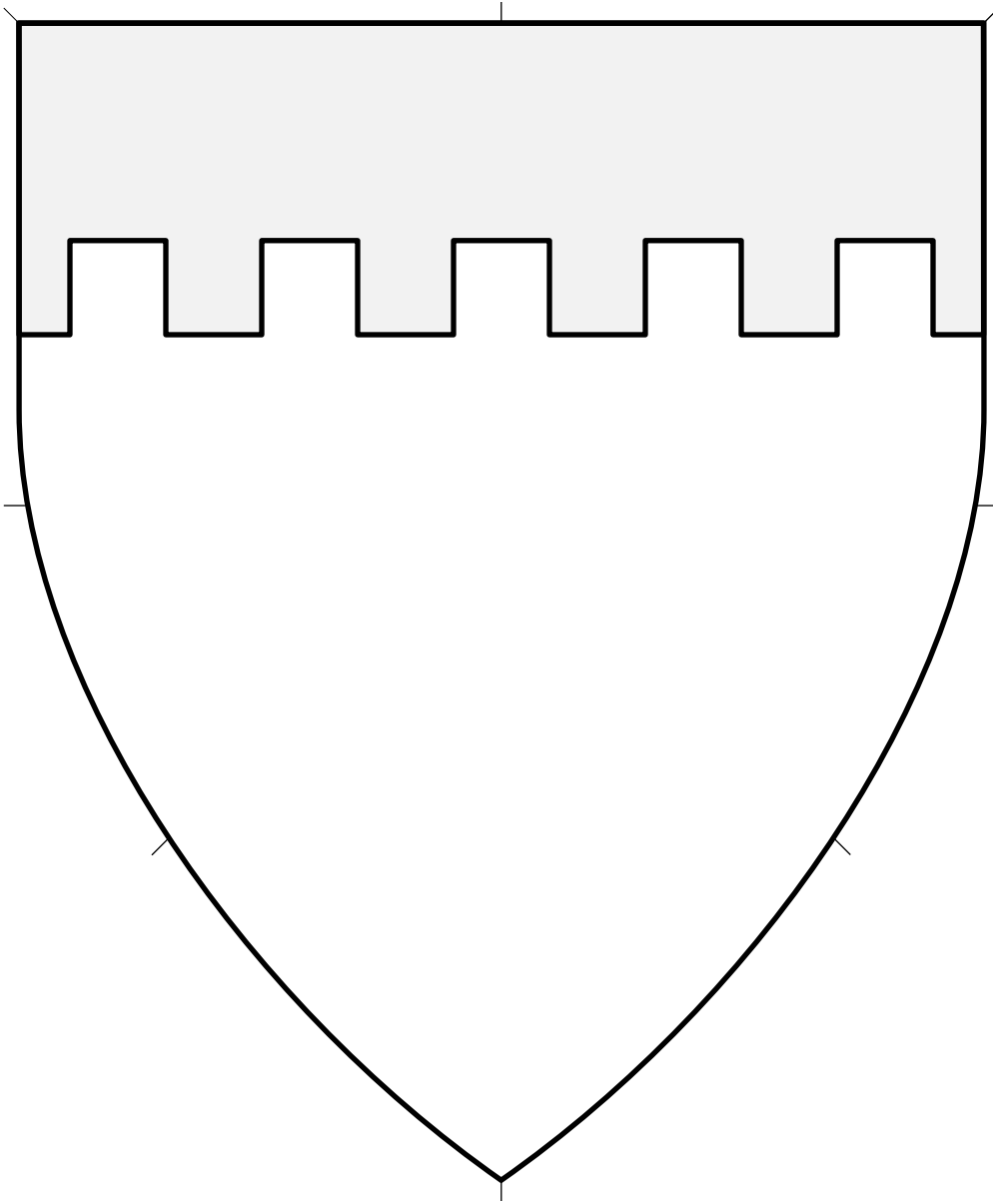

Peripheral ordinary.

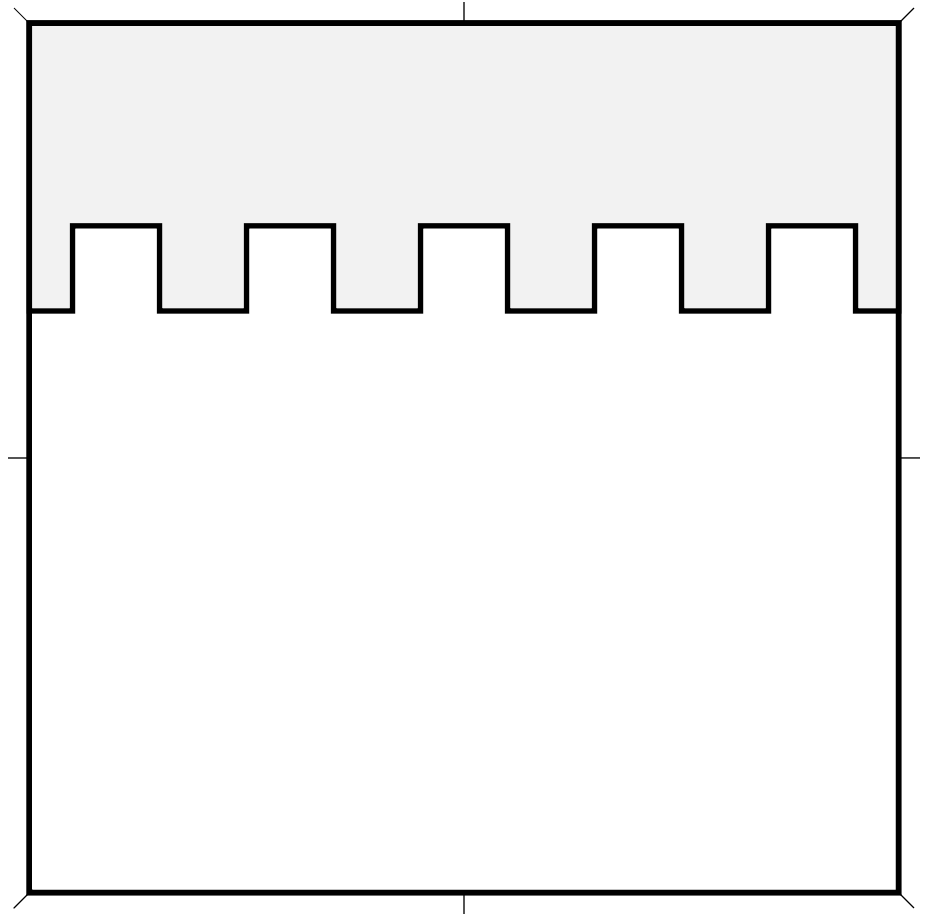

Chief Embattled (2) 4.293

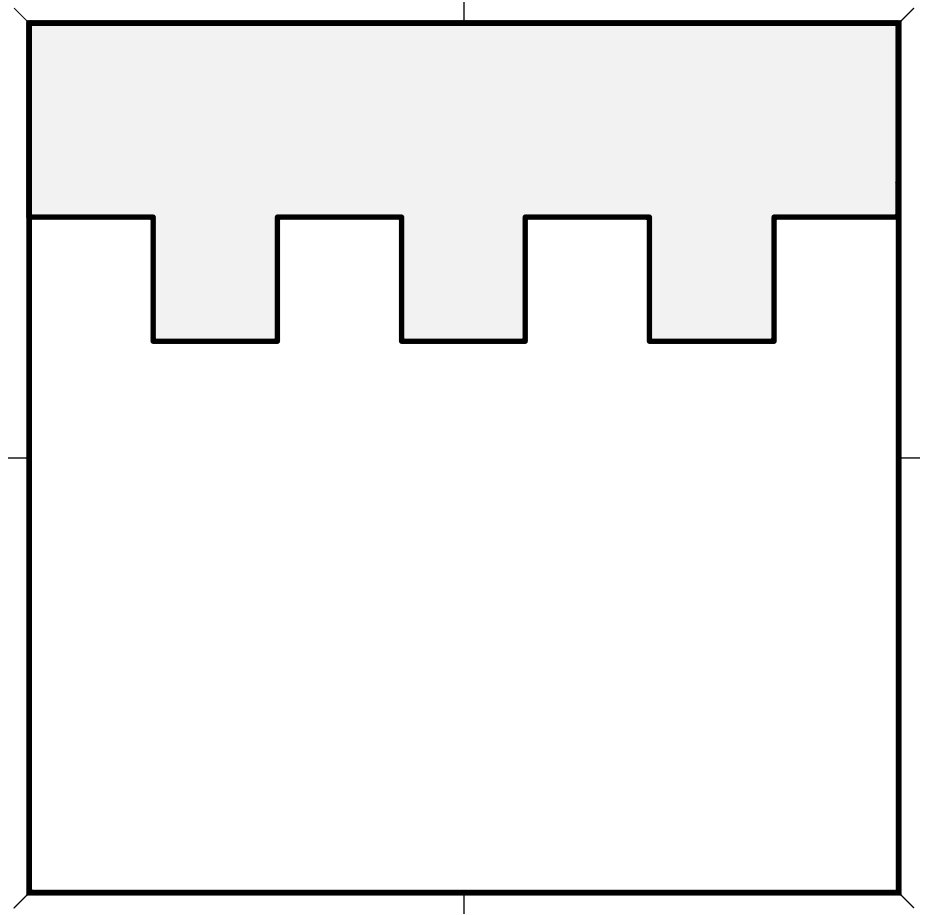
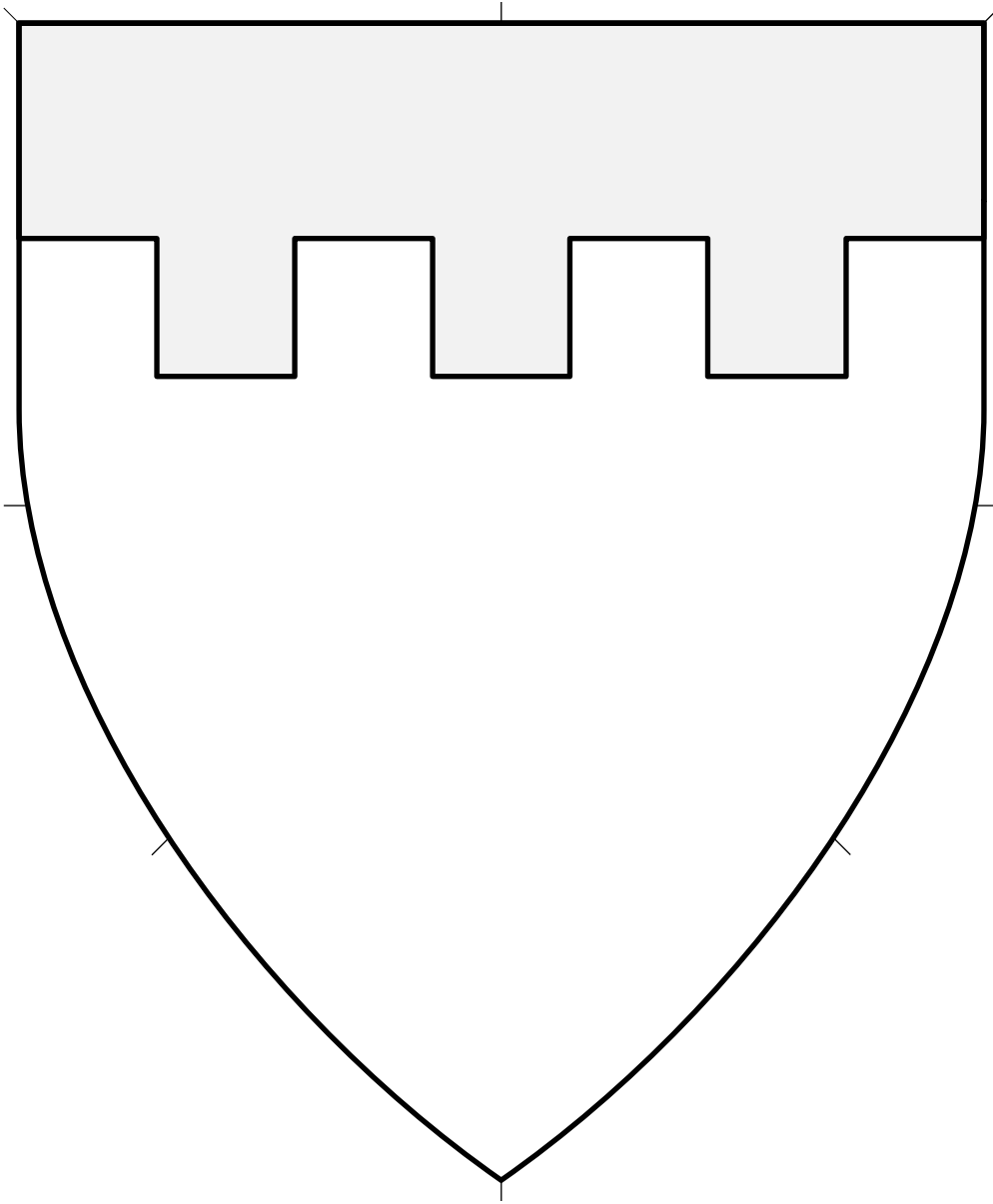

Peripheral ordinary.

Source: Viking Answer Lady SVG Images For Heraldry.
Artist: Gunnvôr silfrahárr. Adapted by Mathghamhain Ua Ruadháin.

Chief Embattled (3) 4.294

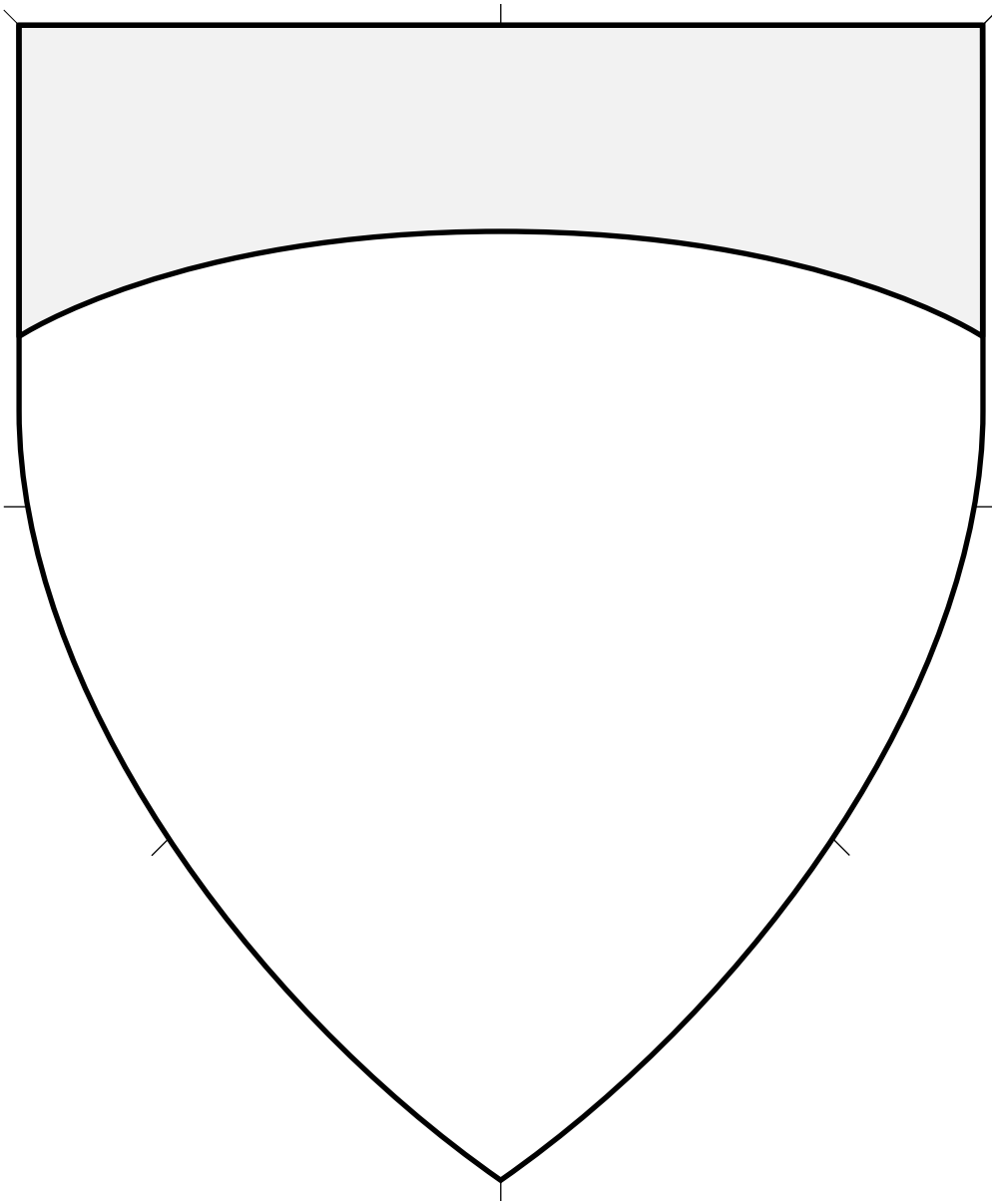

Peripheral ordinary.

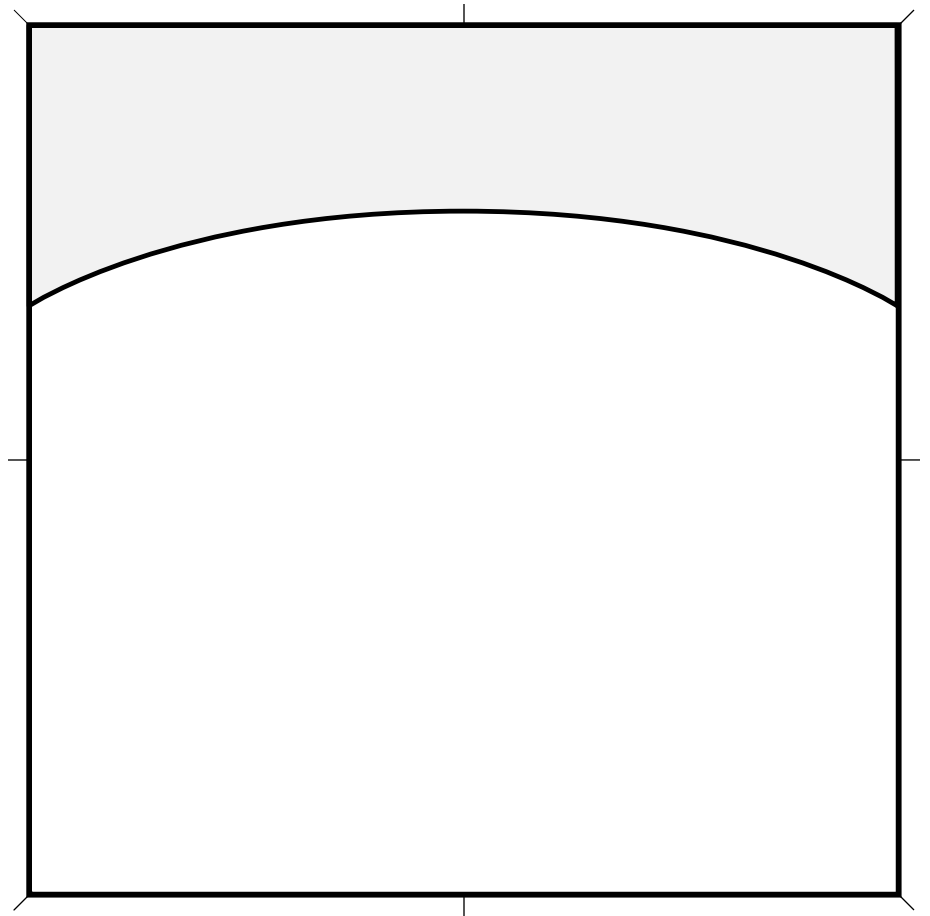

Chief Enarched (1) 4.295

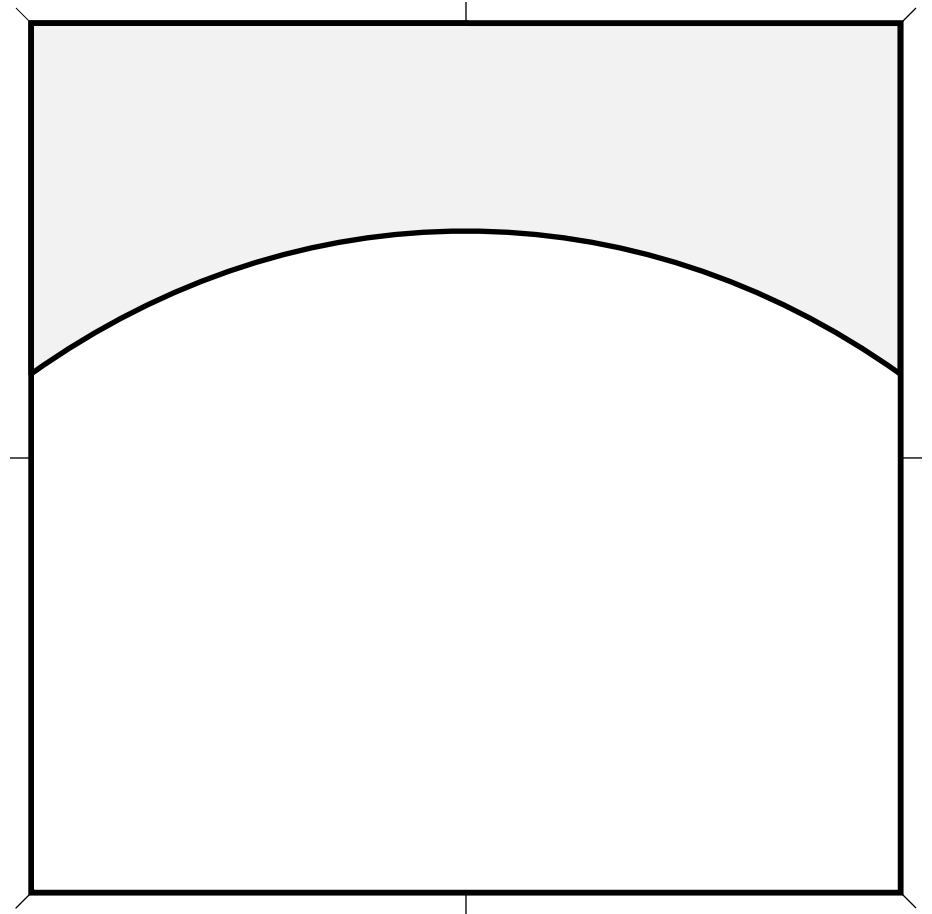
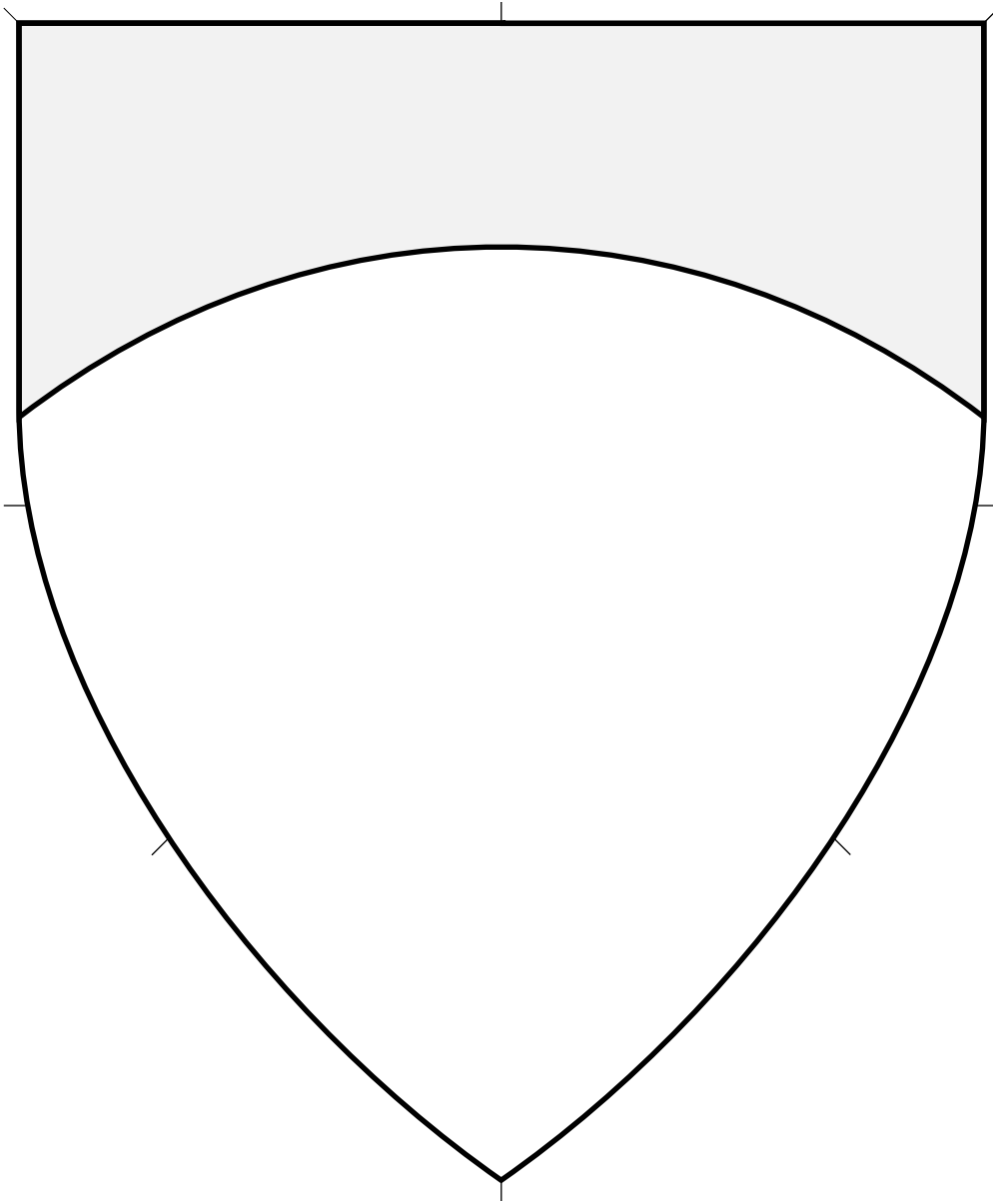

Peripheral ordinary.

Source: Viking Answer Lady SVG Images For Heraldry.
Artist: Gunnvôr silfrahárr. Adapted by Mathghamhain Ua Ruadháin.

Chief Enarched (2) 4.296

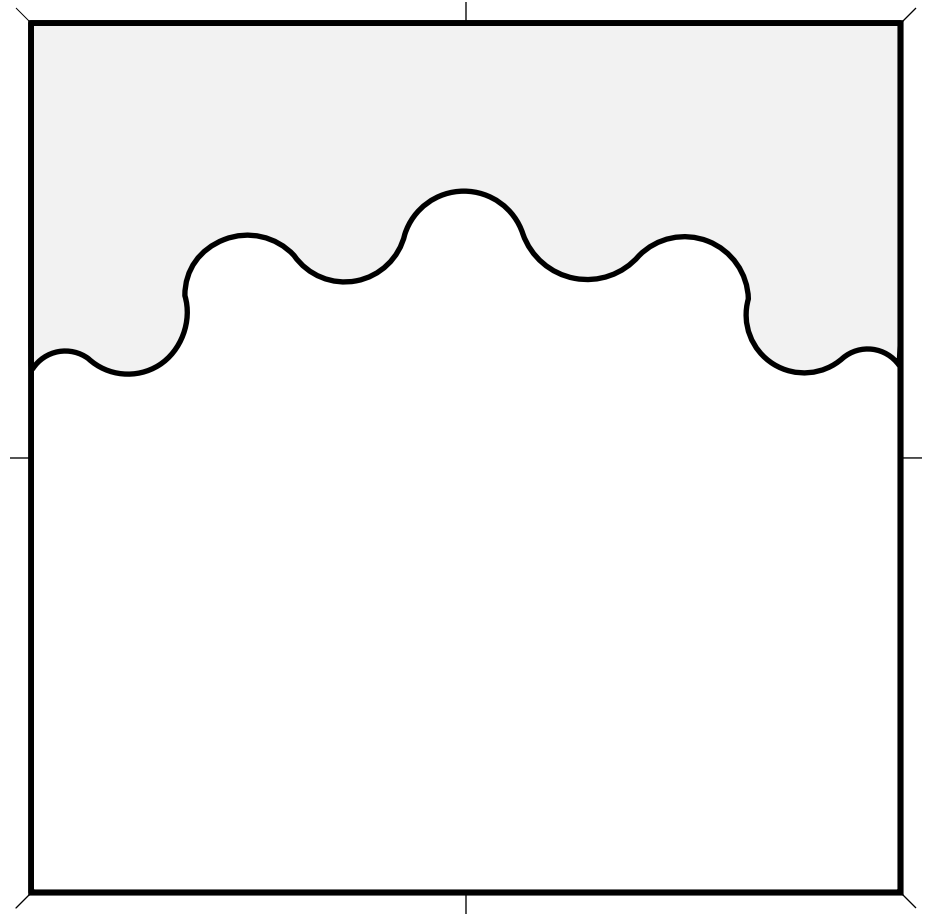
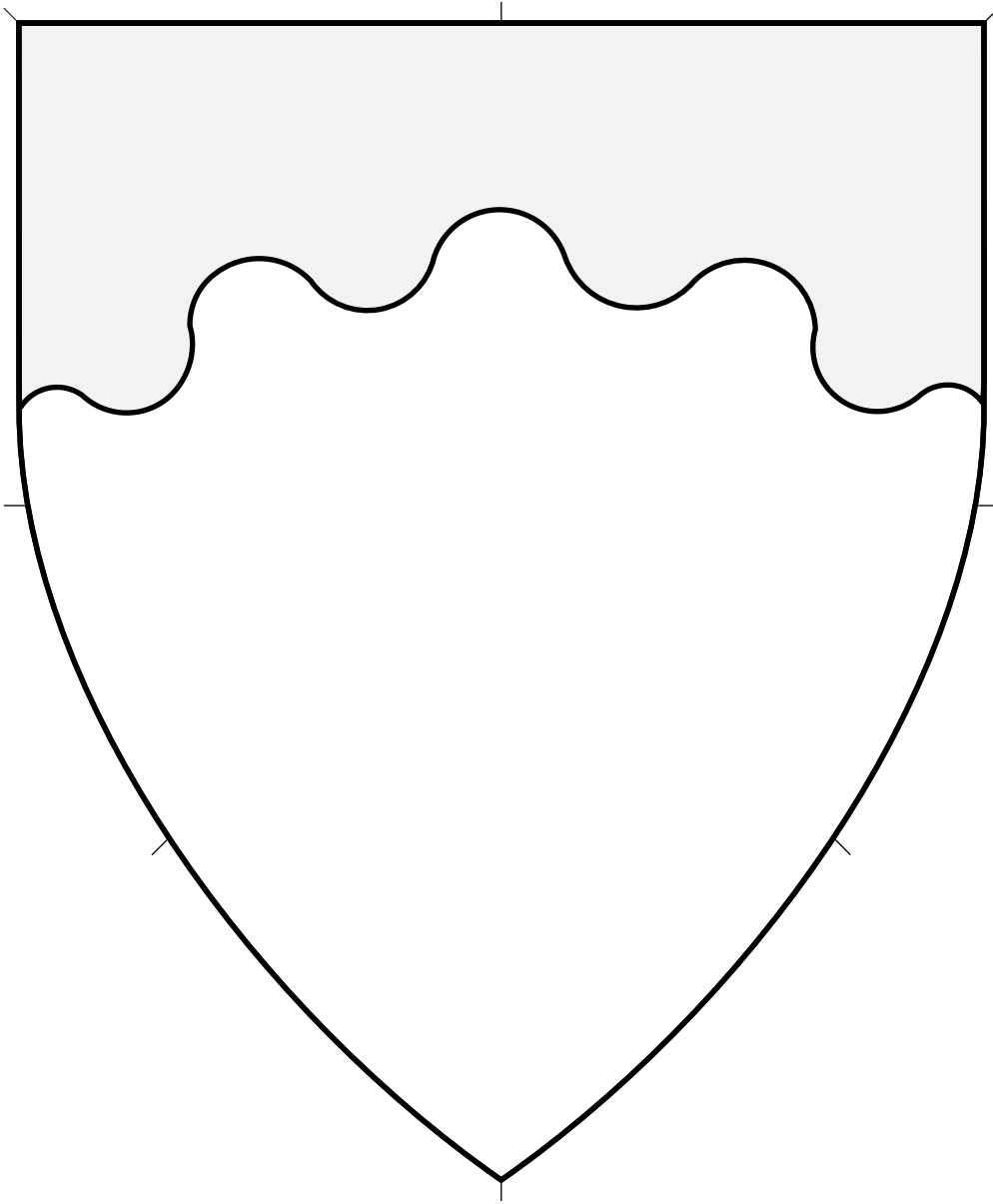

Peripheral ordinary.

Source: Viking Answer Lady SVG Images For Heraldry.
Artist: Gunnvôr silfrahárr.

Chief Enarched Wavy 4.297

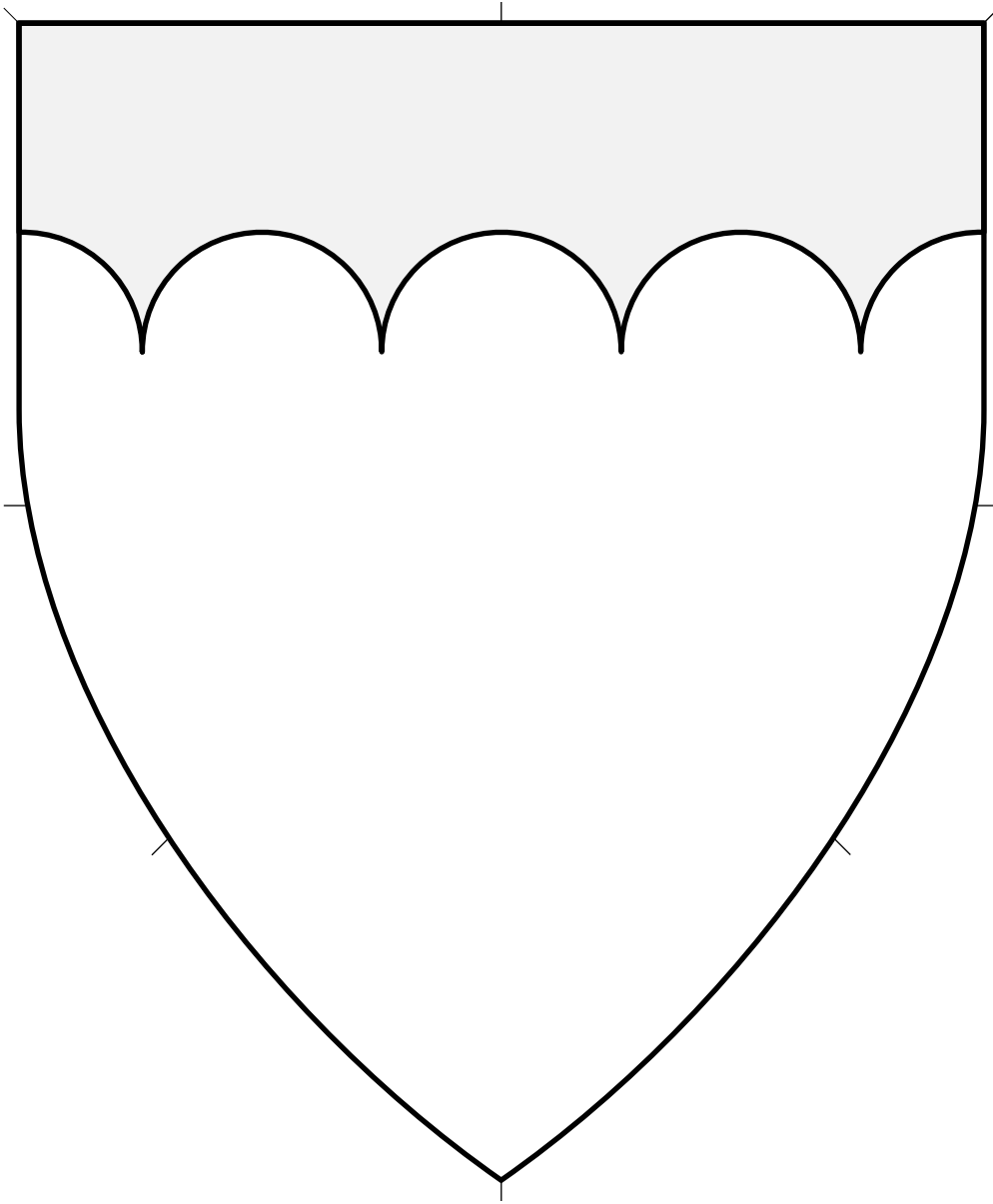

Peripheral ordinary.

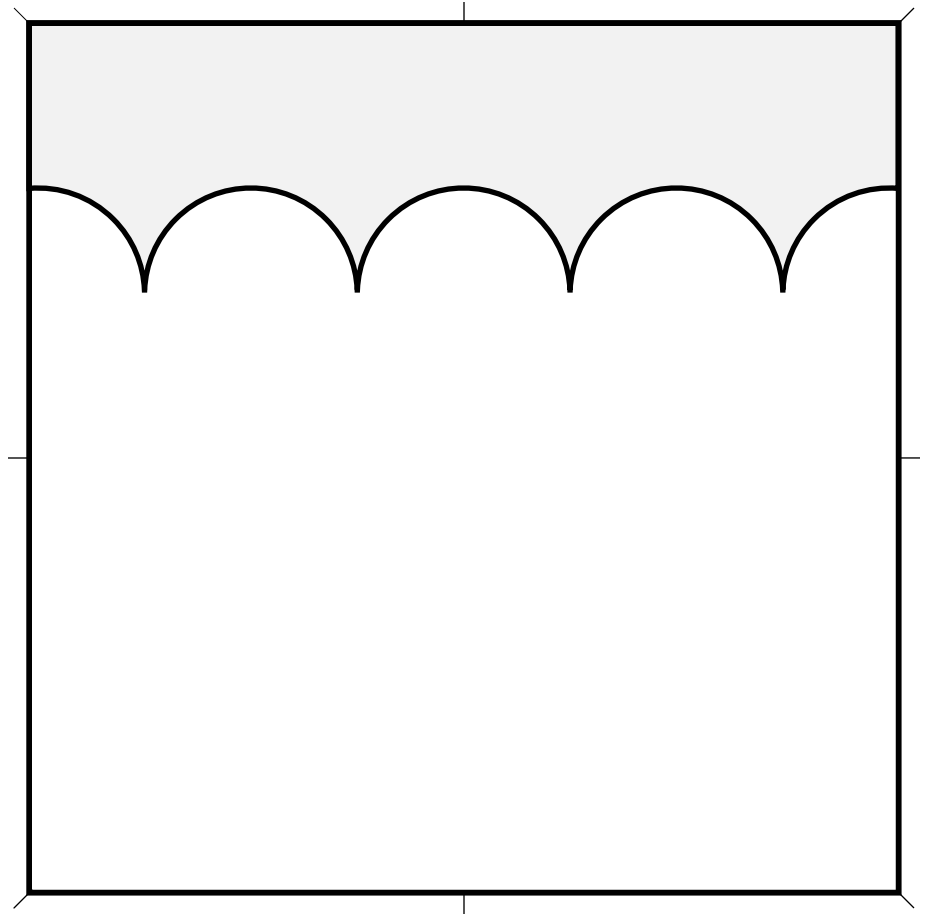

Chief Engrailed (1) 4.298

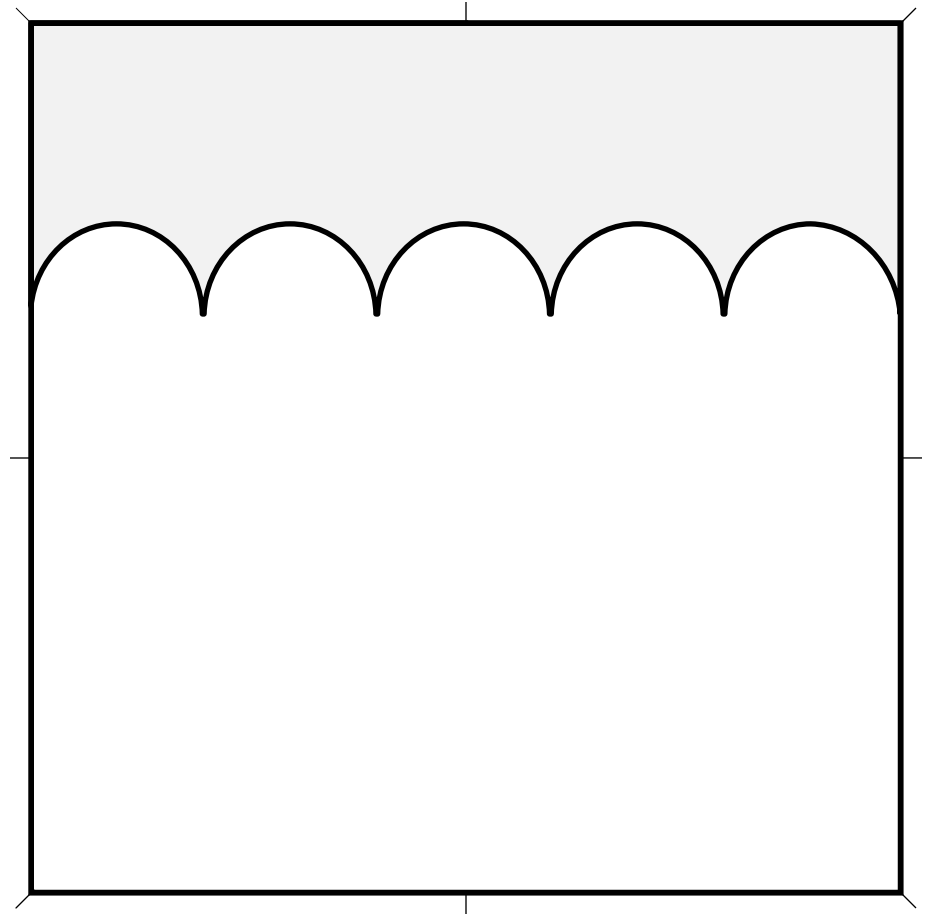
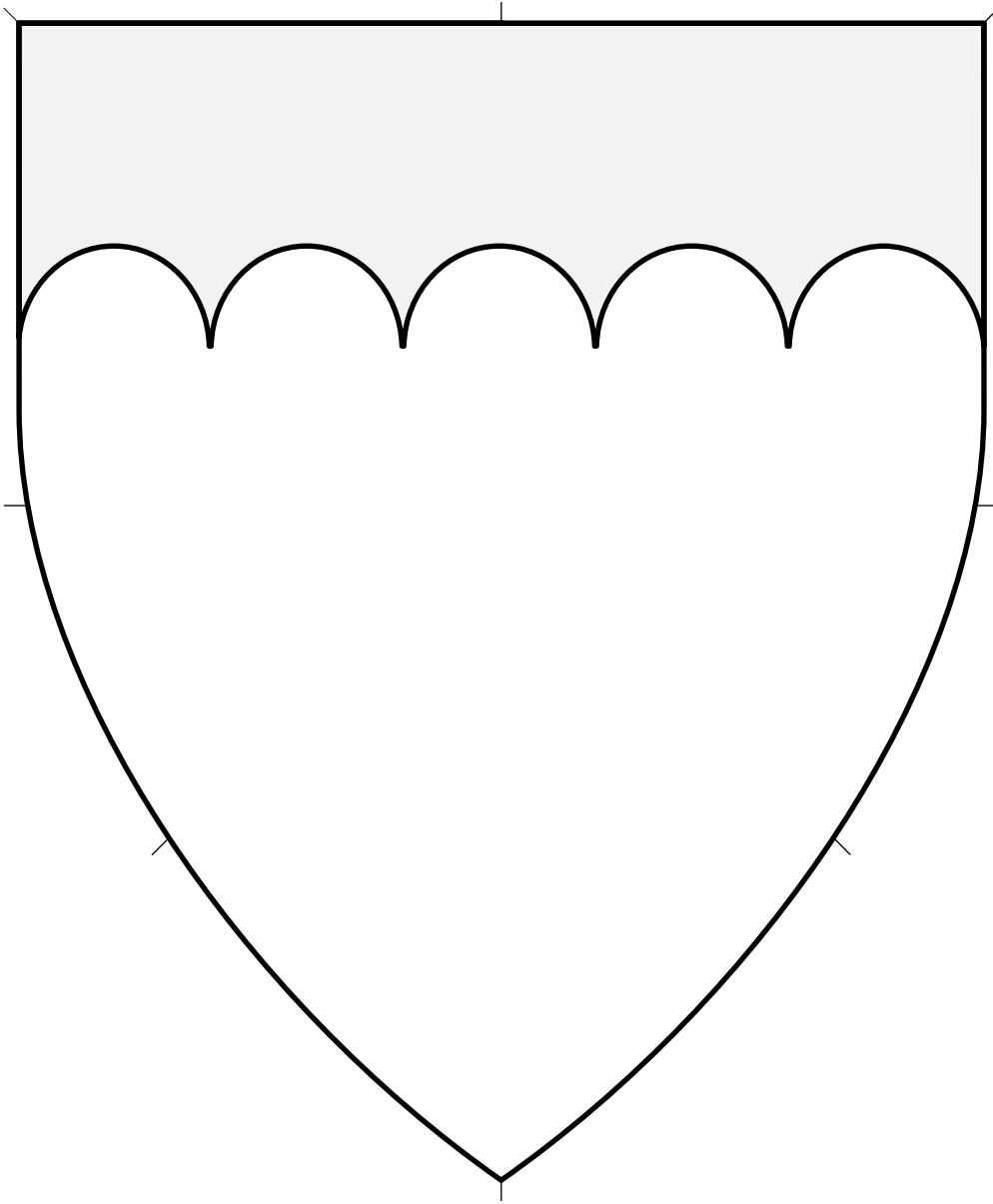

Peripheral ordinary.

Source: Viking Answer Lady SVG Images For Heraldry.
Artist: Gunnvôr silfrahárr. Adapted by Mathghamhain Ua Ruadháin.

Chief Engrailed (2) 4.299

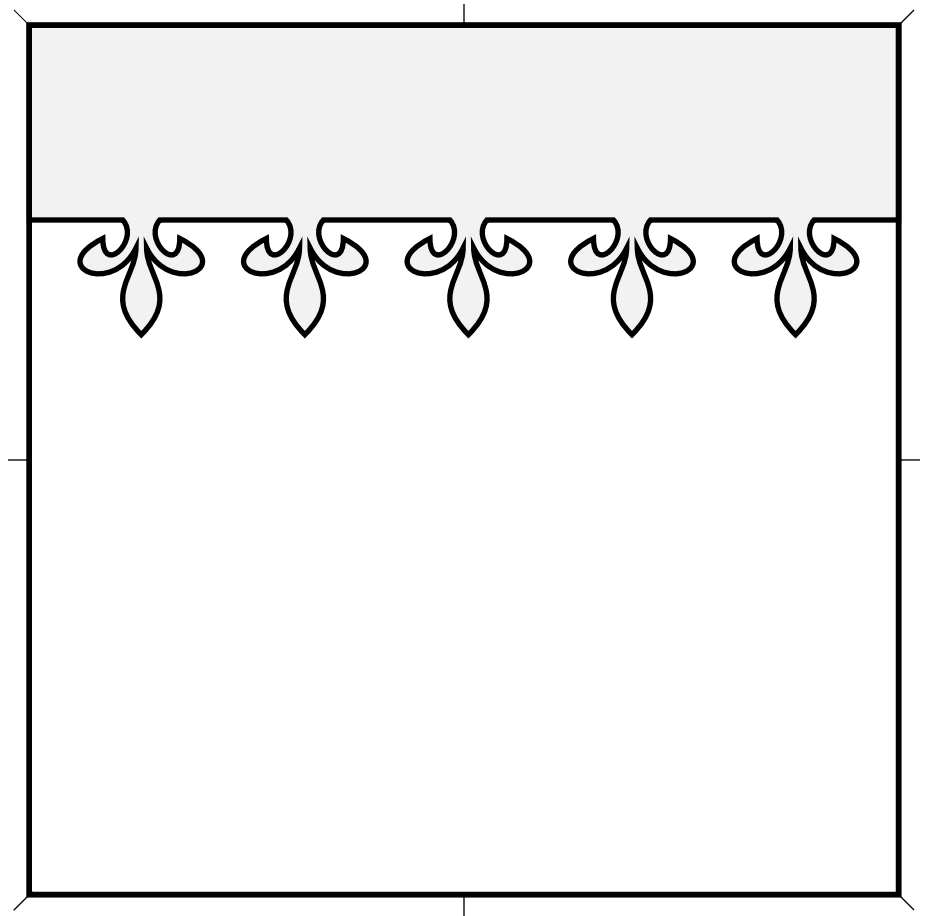
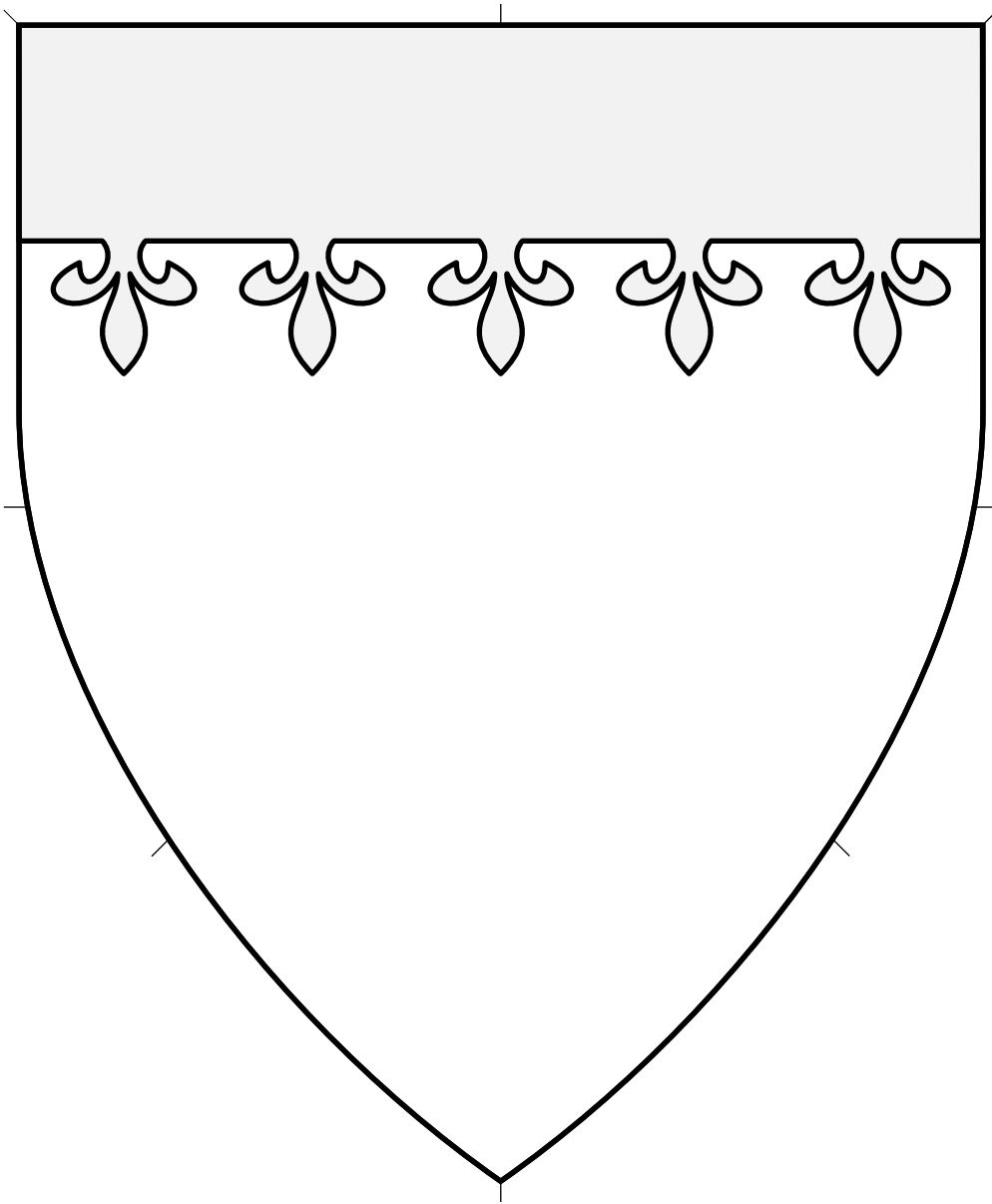

Peripheral ordinary.
Considered a step from core practice (SFCP).

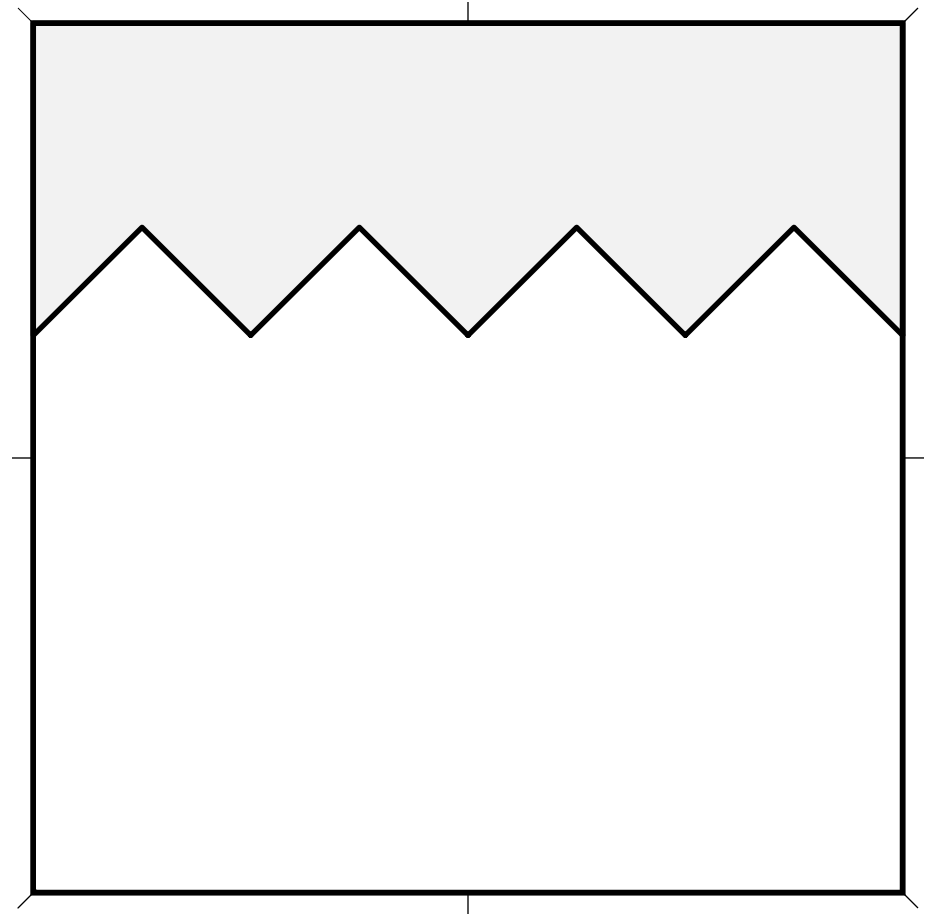
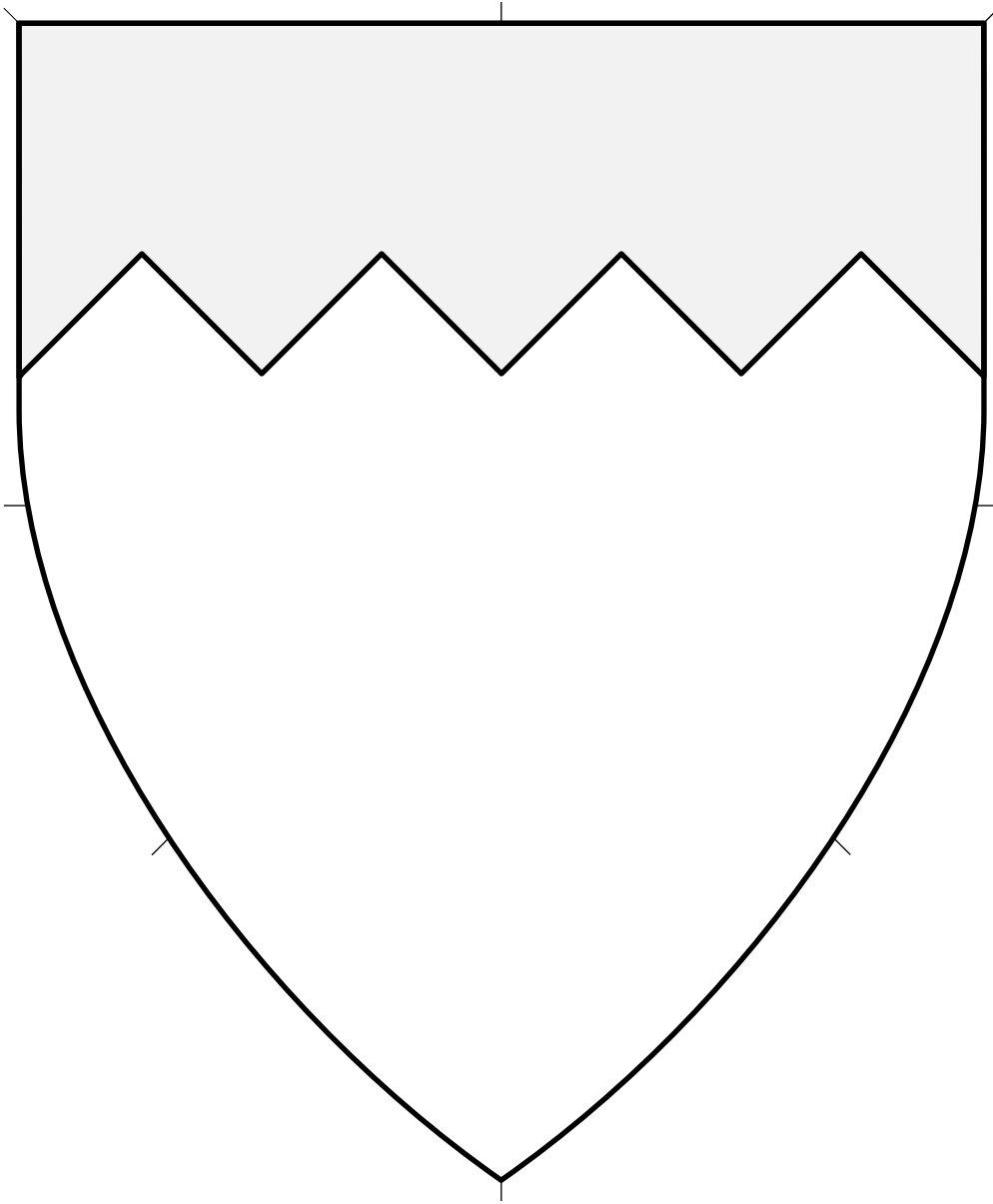

Peripheral ordinary.

Source: Walters Ms. W.847. Artist unknown.
(Arms of Randolph, folio 11r.)

Chief Indented (1) 4.301

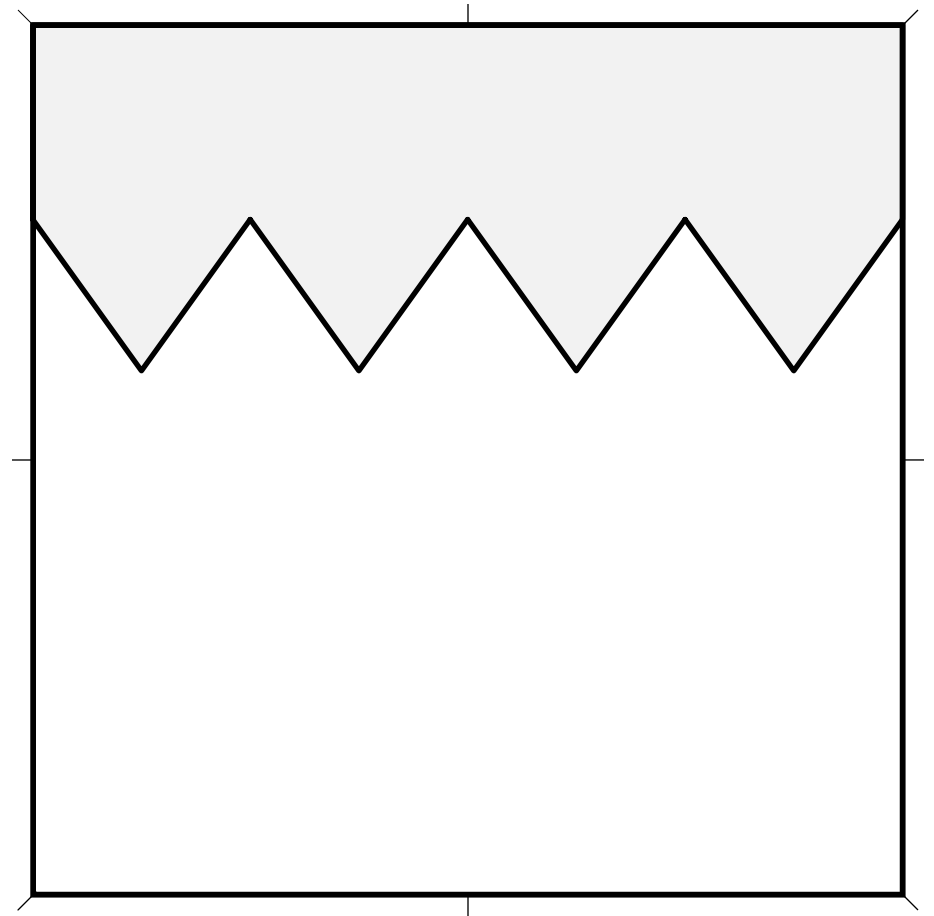
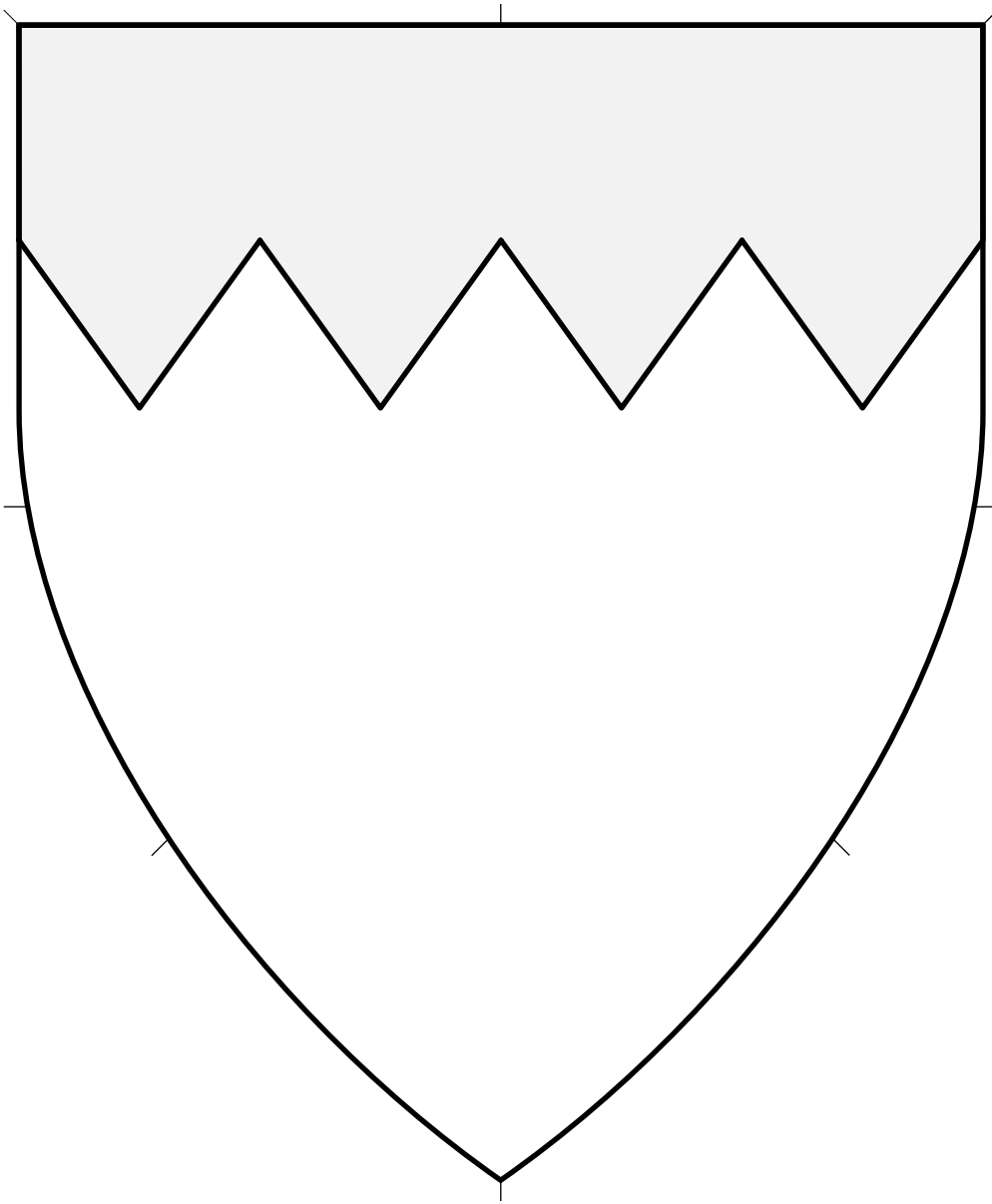

Peripheral ordinary.

Source: English Arms A. Artist unknown. (Page 171.)

Chief Indented (2) 4.302

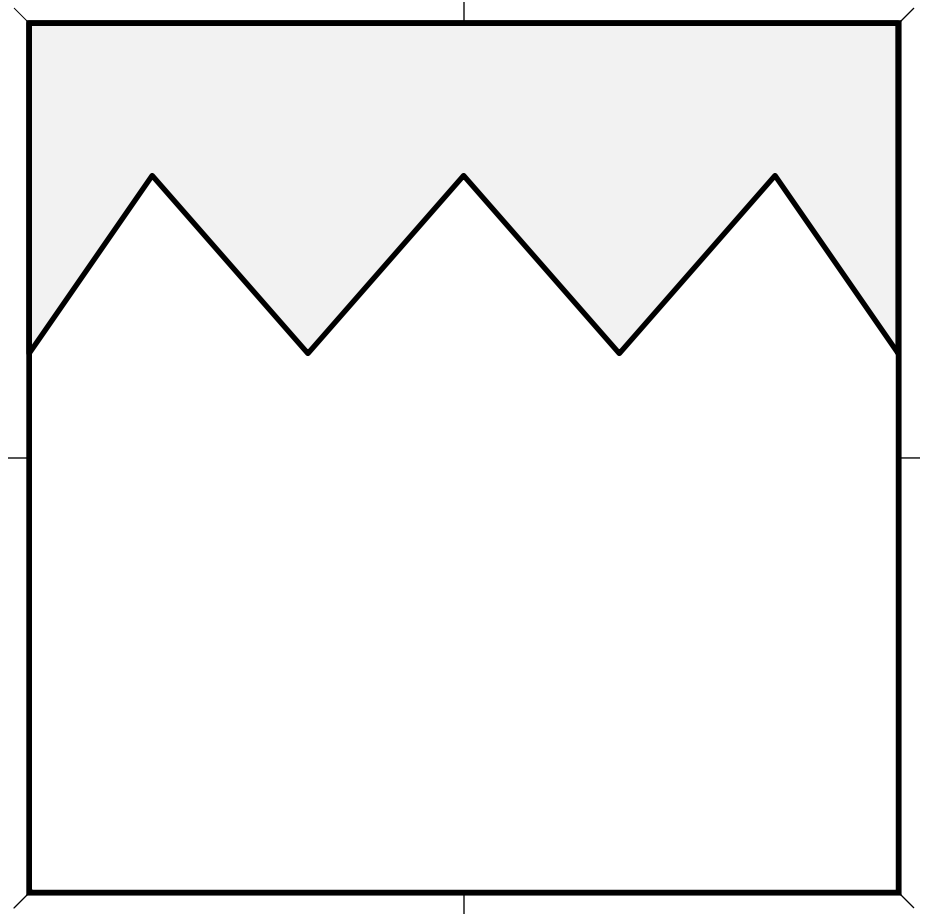
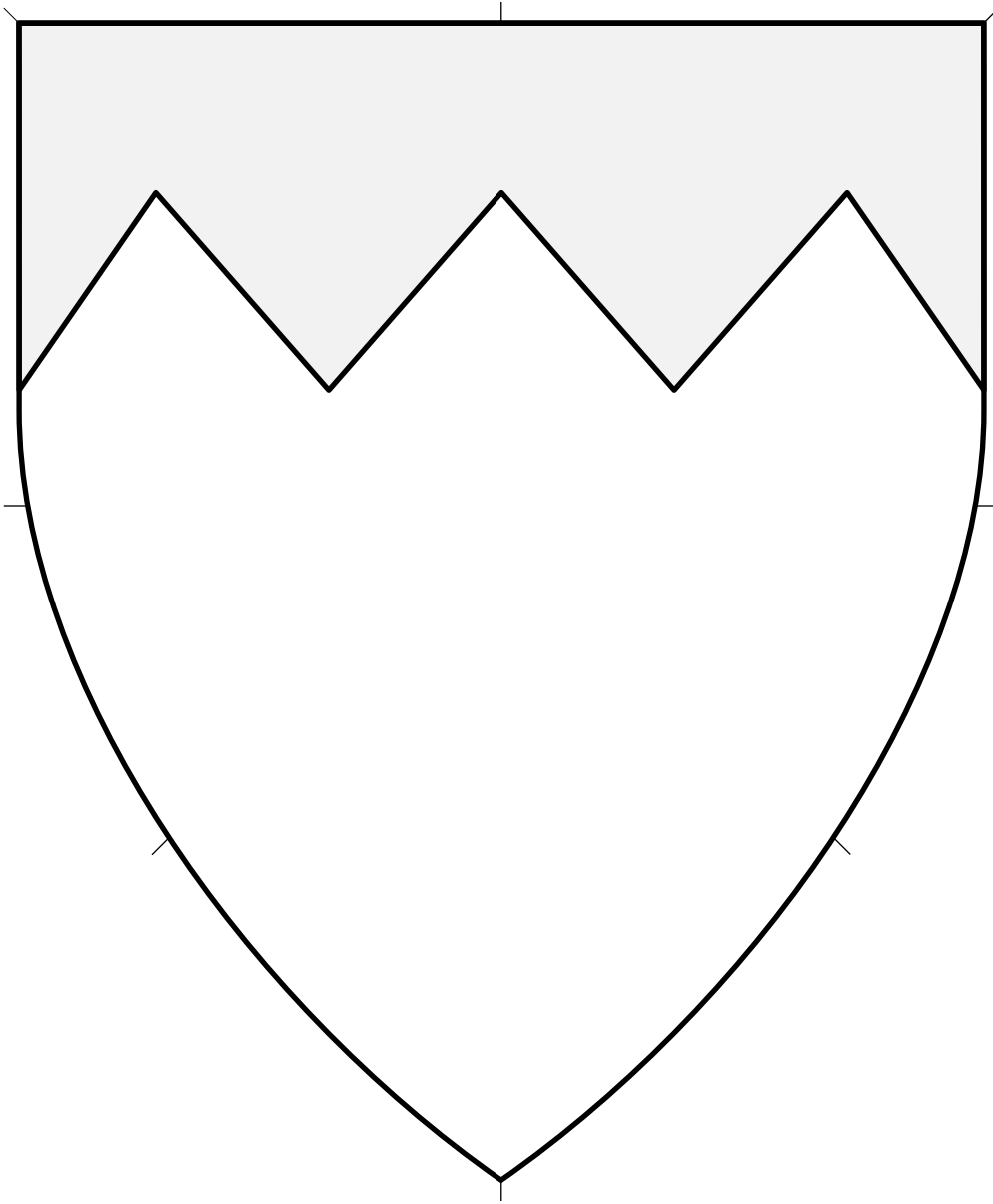

Peripheral ordinary.
Artist: Vémundr Syvursson.

Chief Indented (3) 4.303

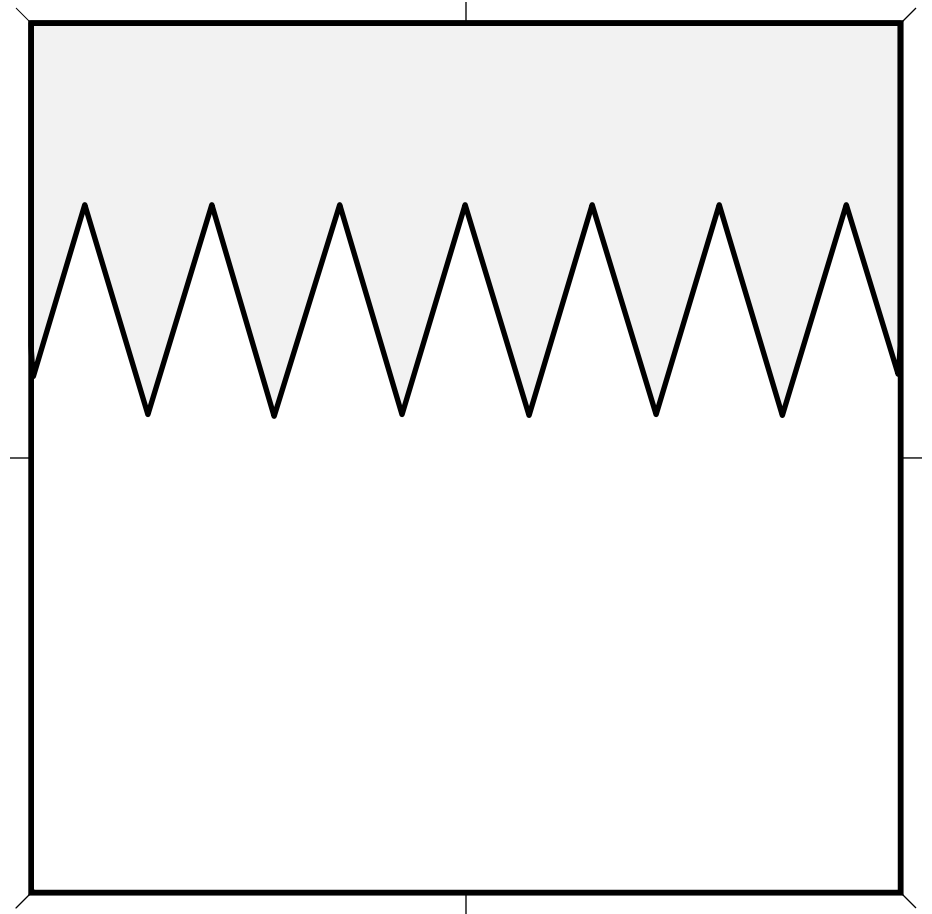
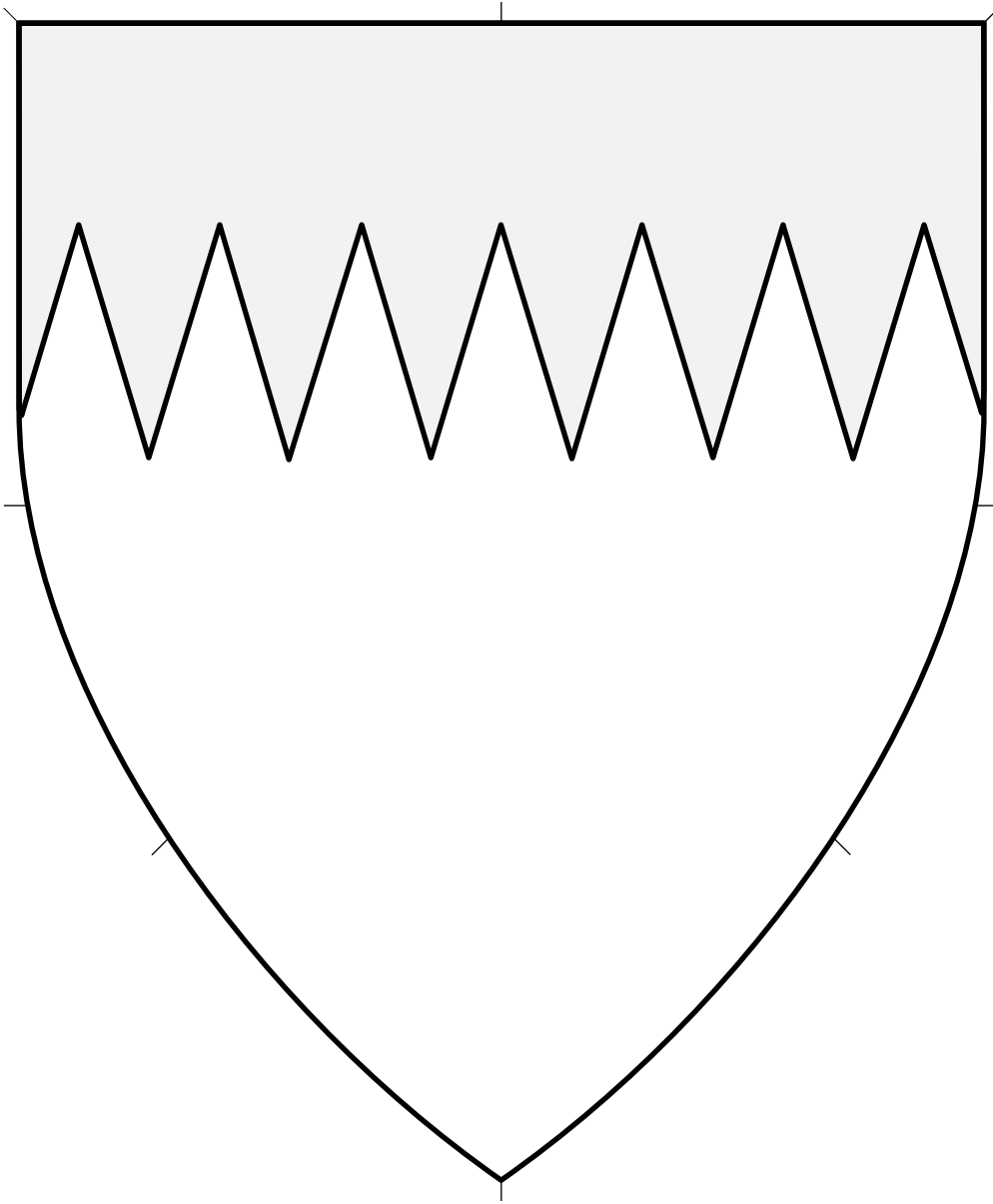

Peripheral ordinary.

Source: Viking Answer Lady SVG Images For Heraldry.
Artist: Gunnvôr silfrahárr. Adapted by Mathghamhain Ua Ruadháin.

Chief Indented (4) 4.304

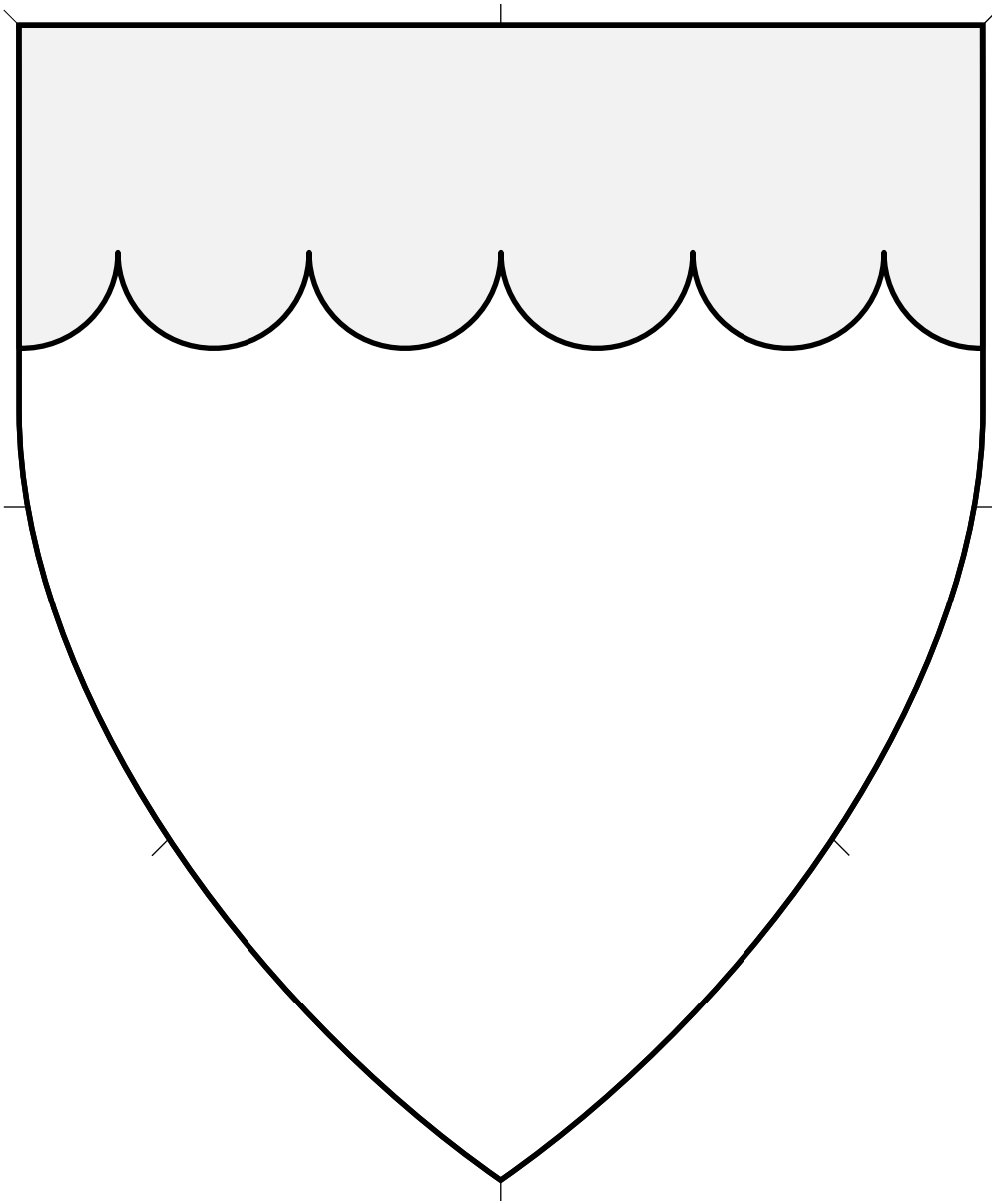

Peripheral ordinary.

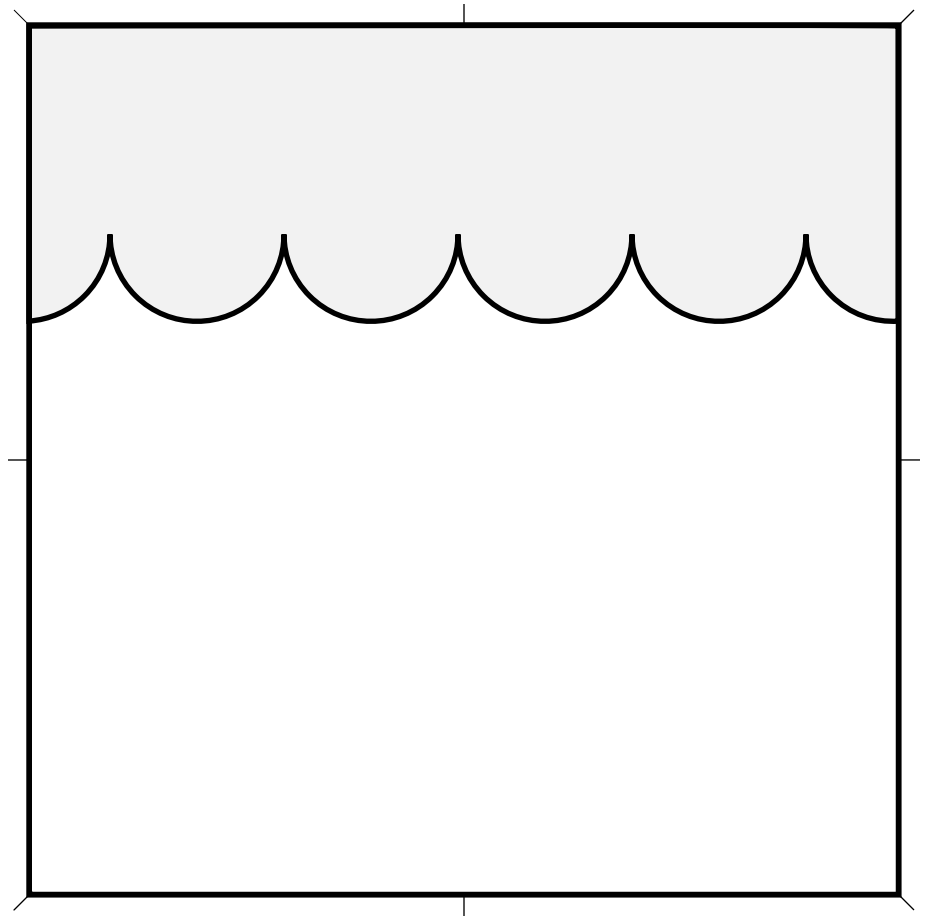

Chief Invected (1) 4.305

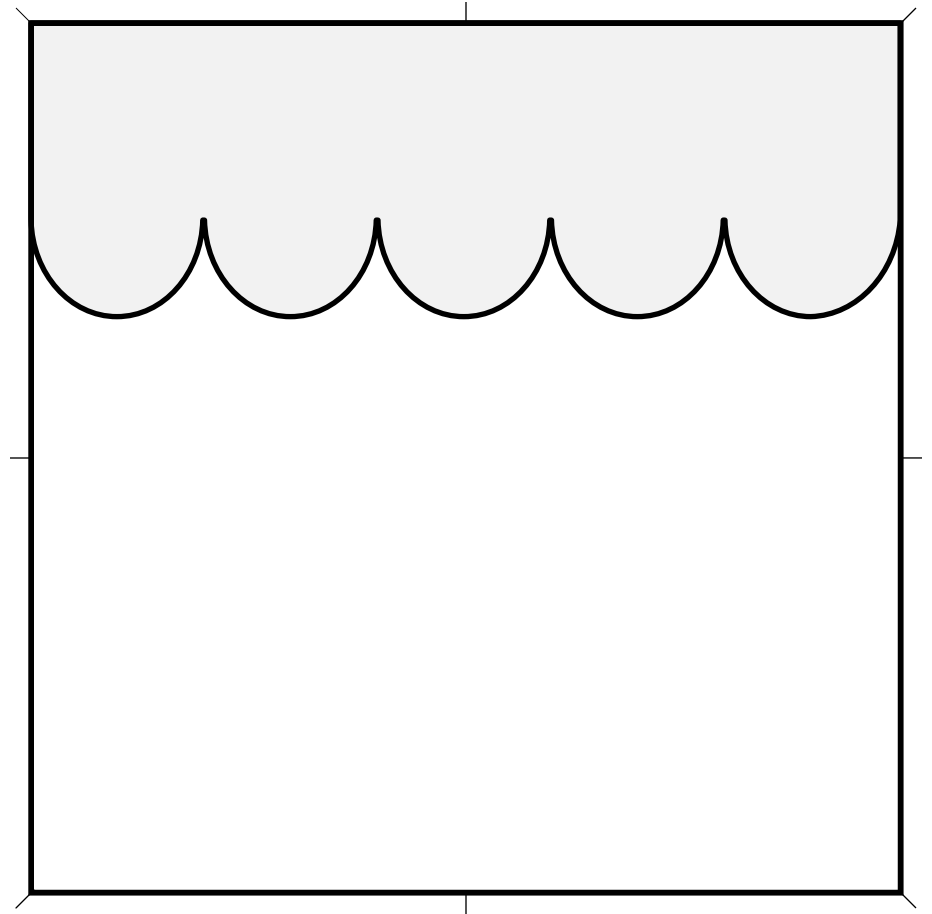
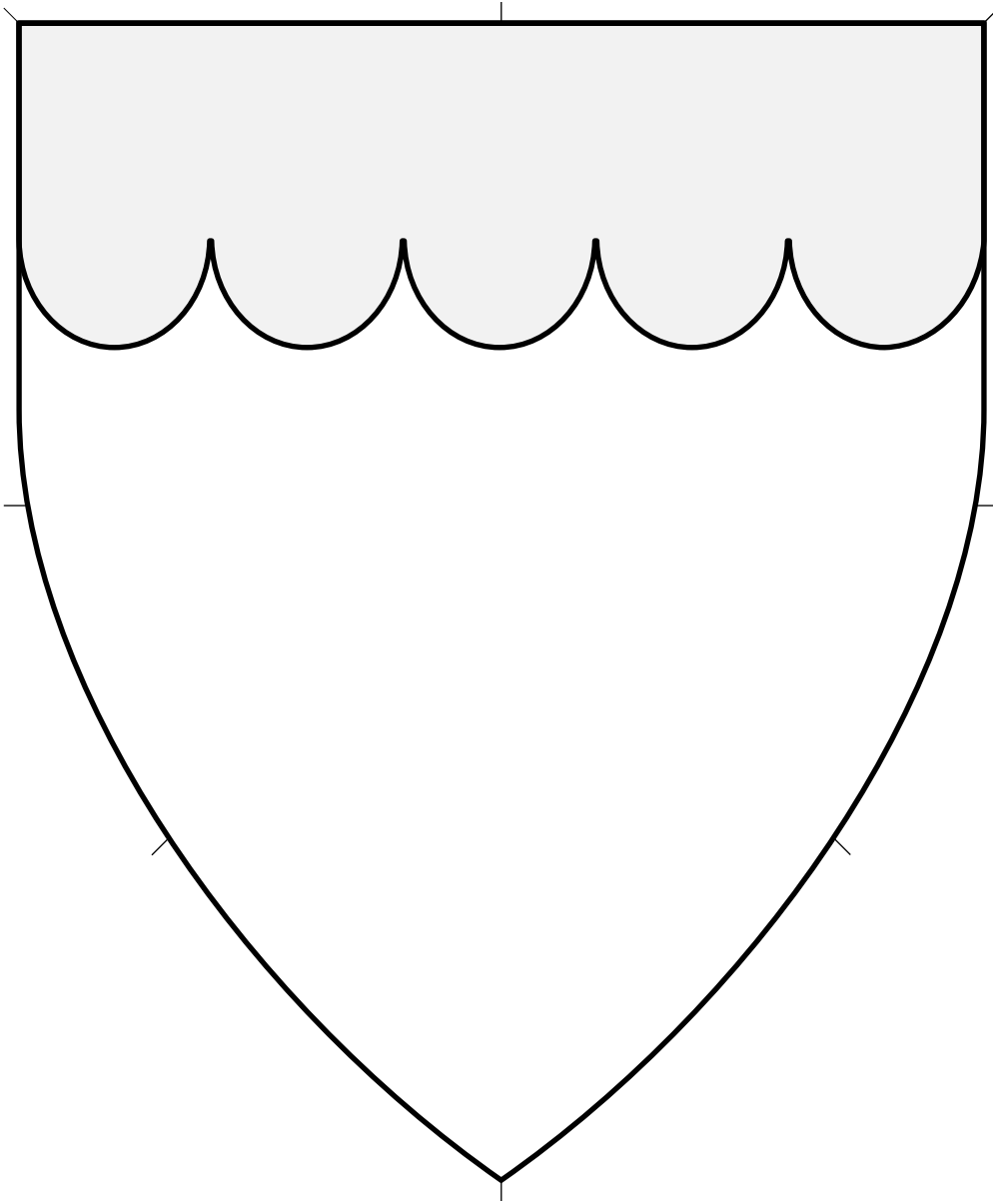

Peripheral ordinary.

Source: Viking Answer Lady SVG Images For Heraldry.
Artist: Gunnvôr silfrahárr. Adapted by Mathghamhain Ua Ruadháin.

Chief Invected (2) 4.306

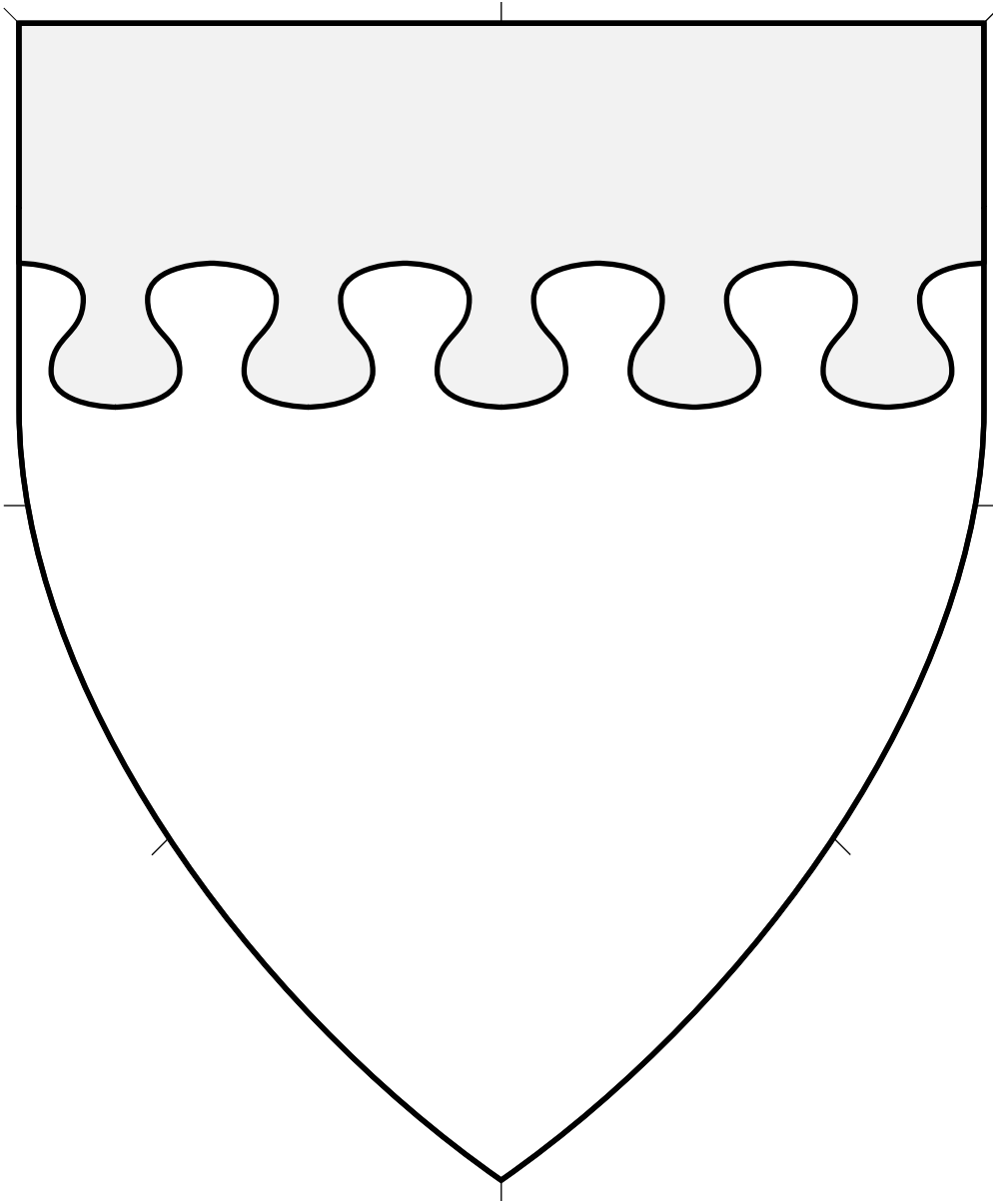

Peripheral ordinary.

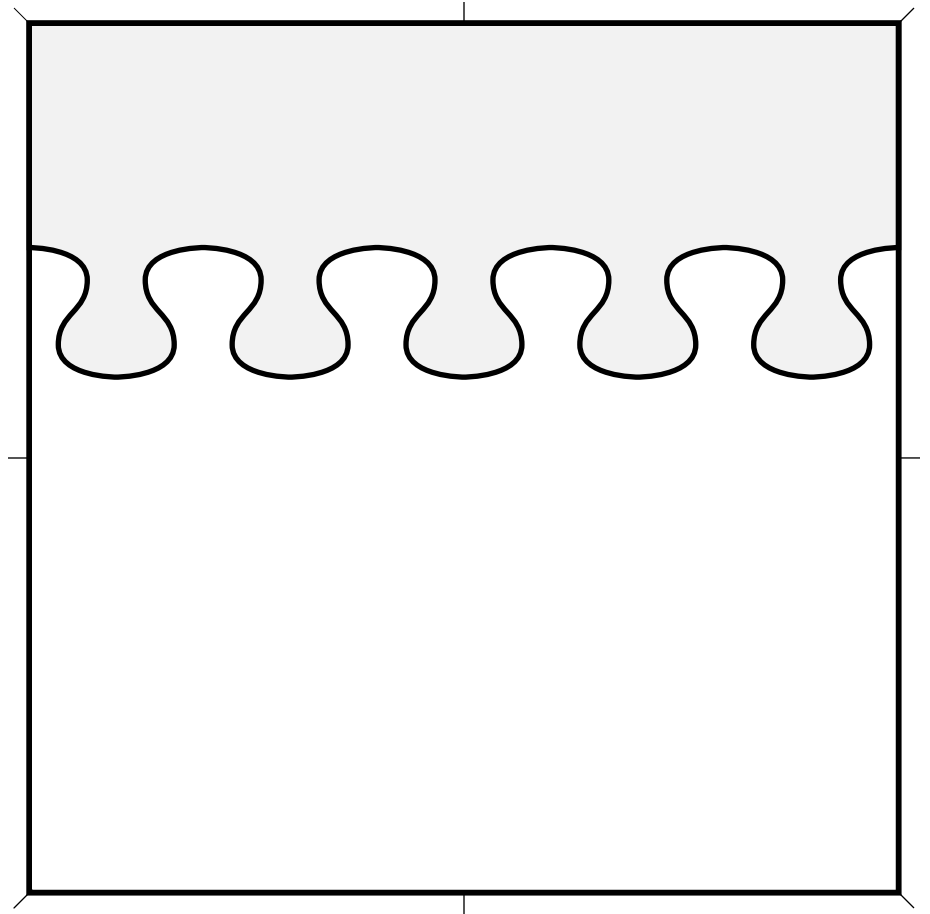

Chief Nebuly (1) 4.307

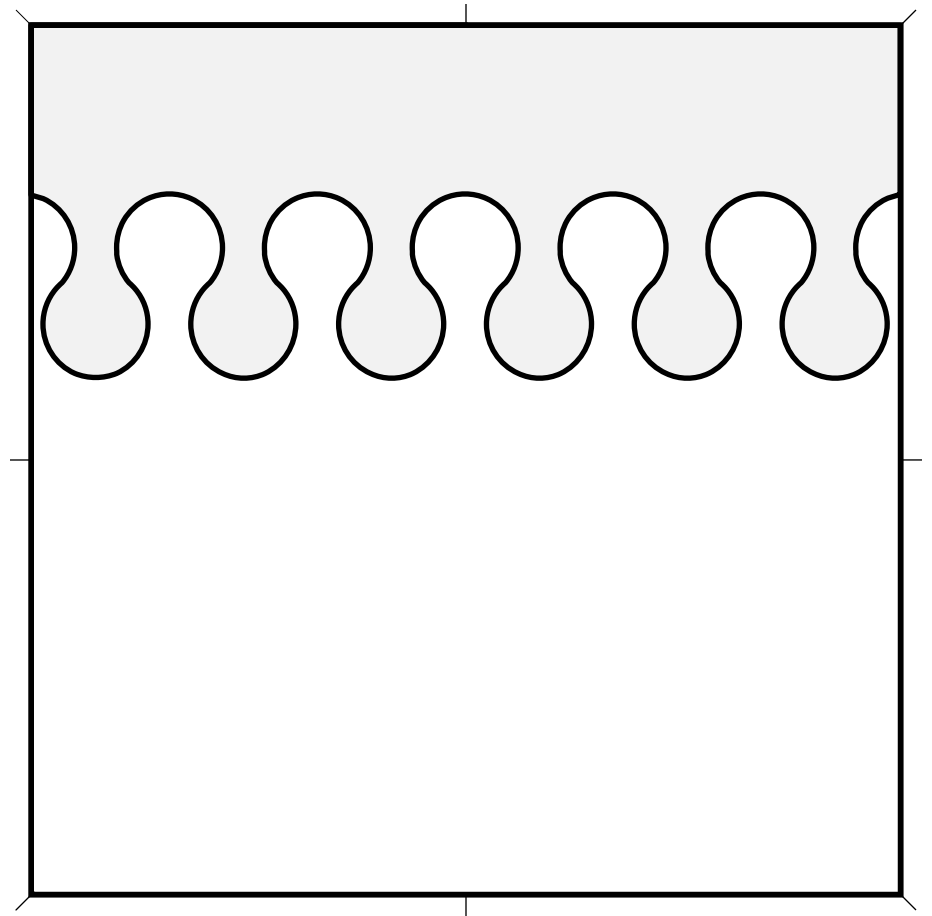
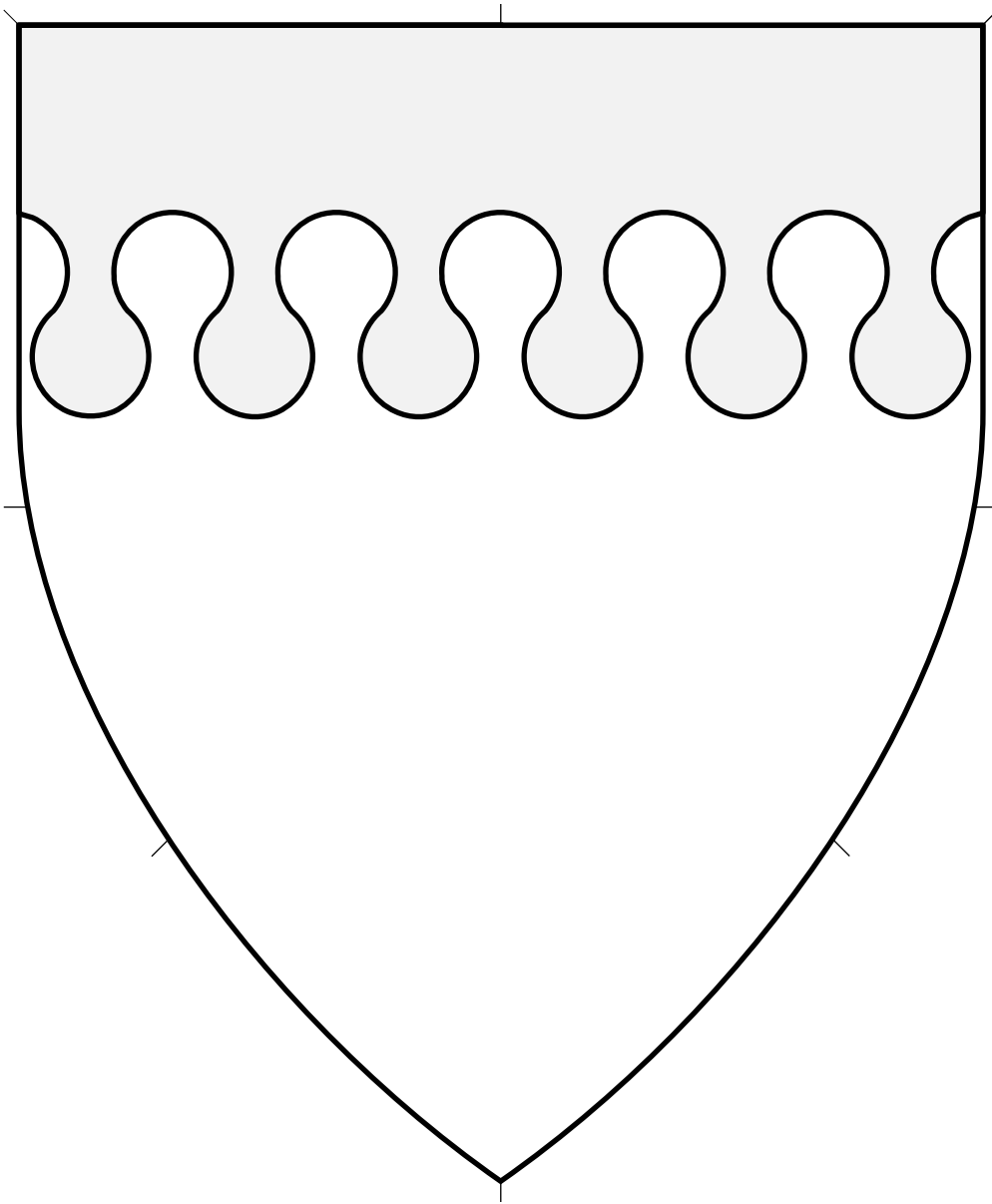

Peripheral ordinary.

Source: Viking Answer Lady SVG Images For Heraldry.
Artist: Gunnvôr silfrahárr. Adapted by Mathghamhain Ua Ruadháin.

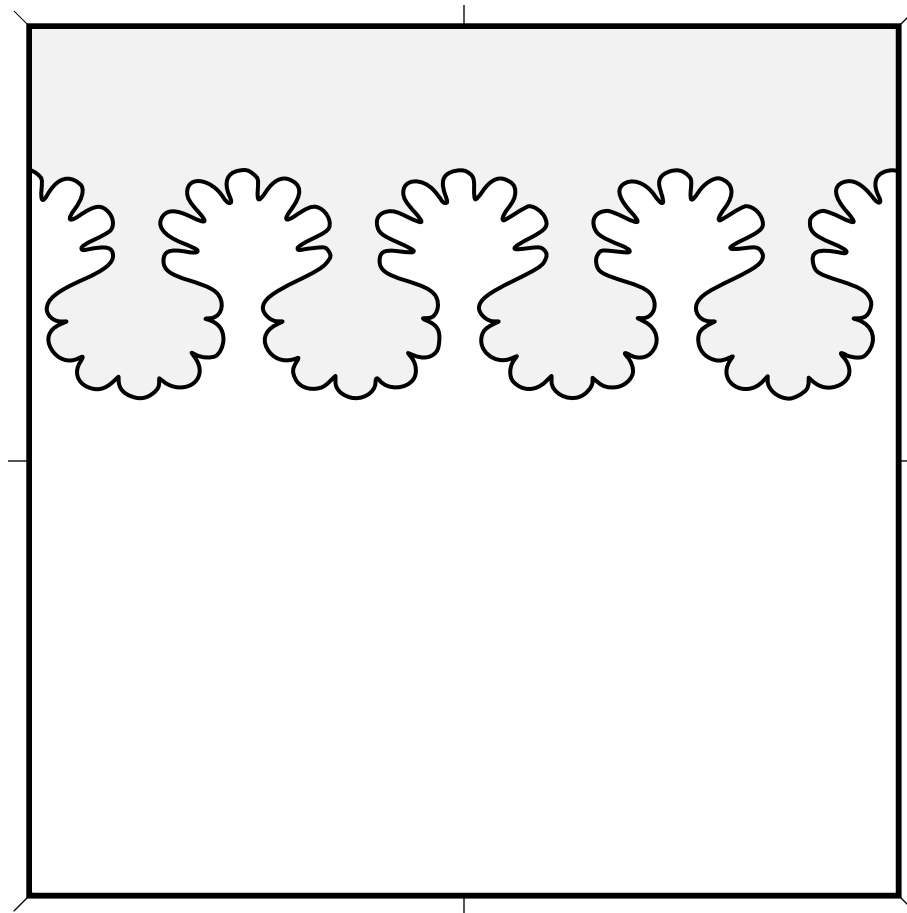
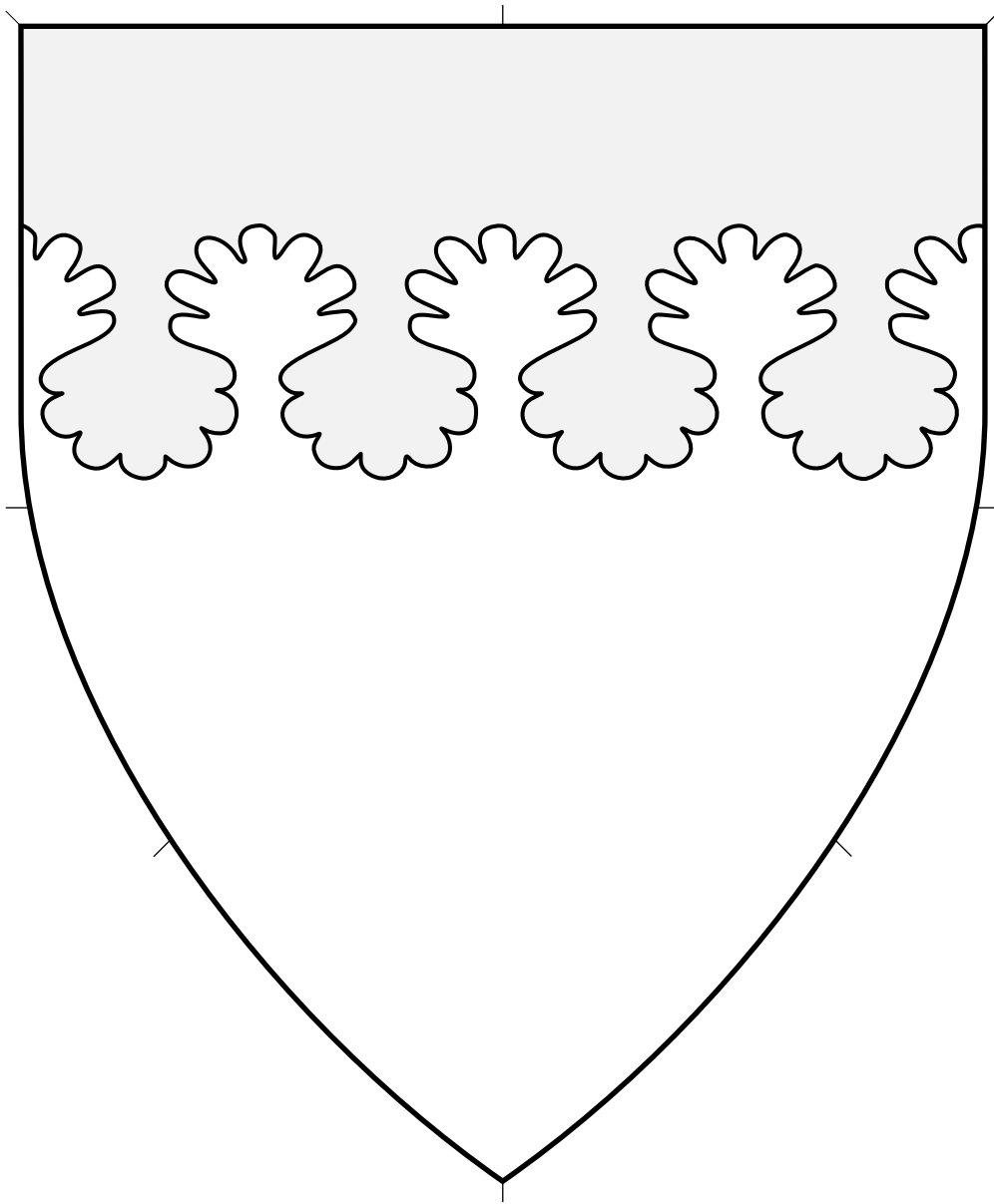

Peripheral ordinary.
Artist: Vémundr Syvursson.

Chief Nebuly (3) 4.309

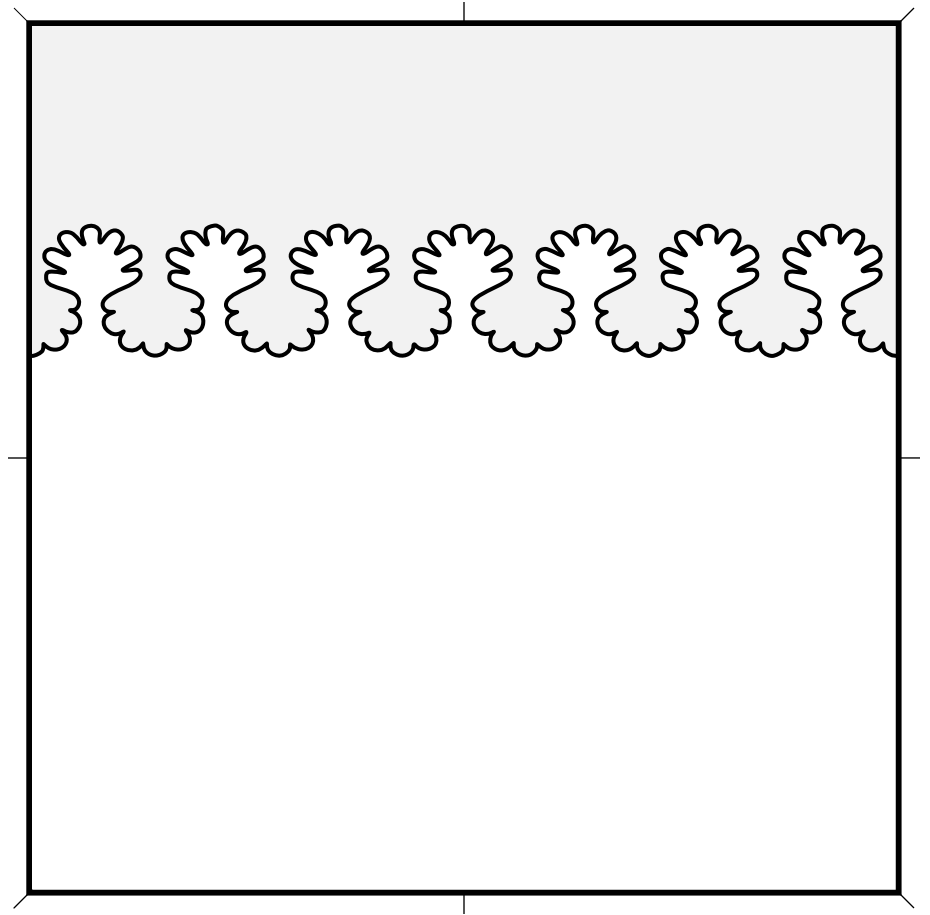
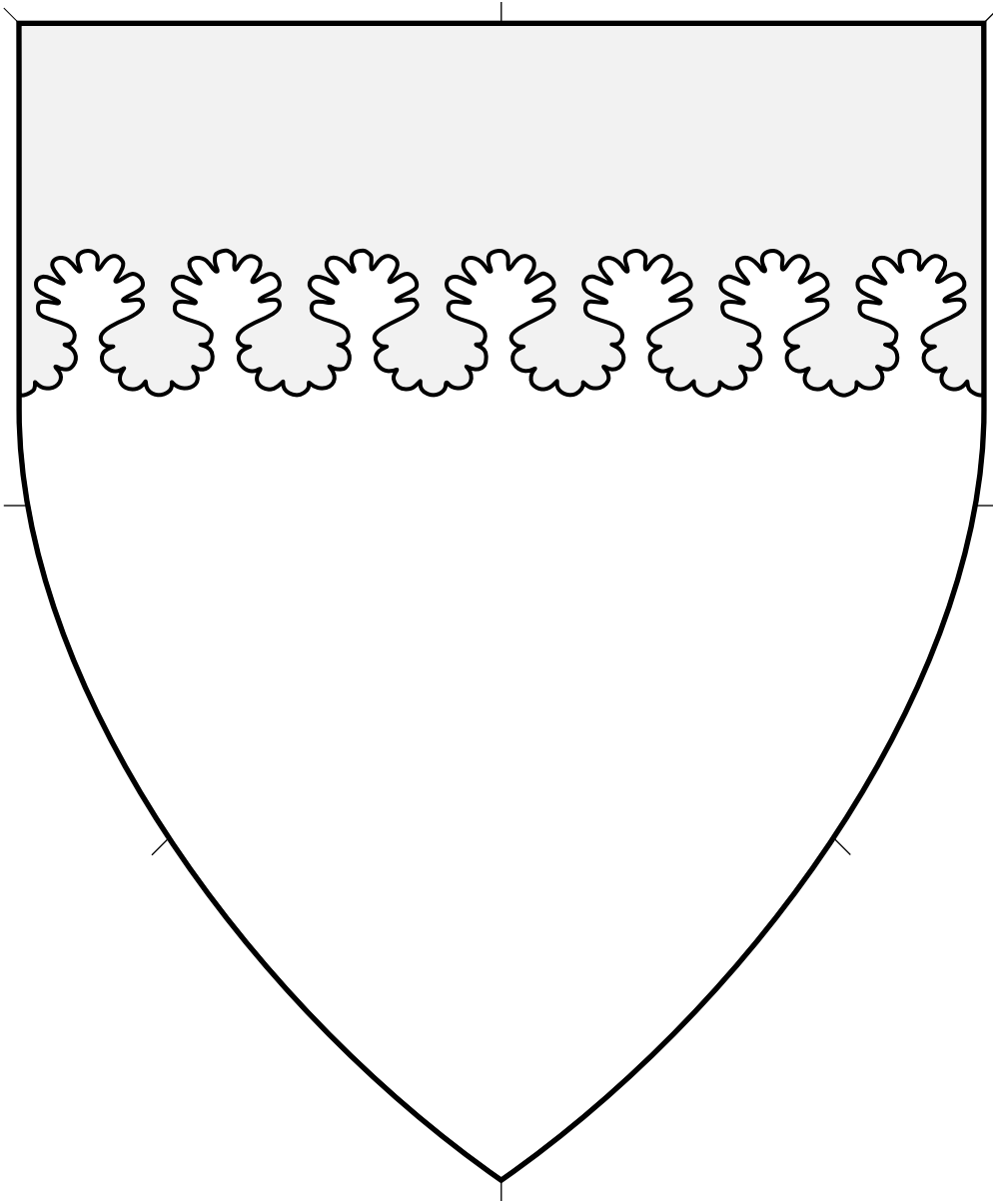

Peripheral ordinary.
Artist: Vémundr Syvursson.

Chief Nebuly (4) 4.310

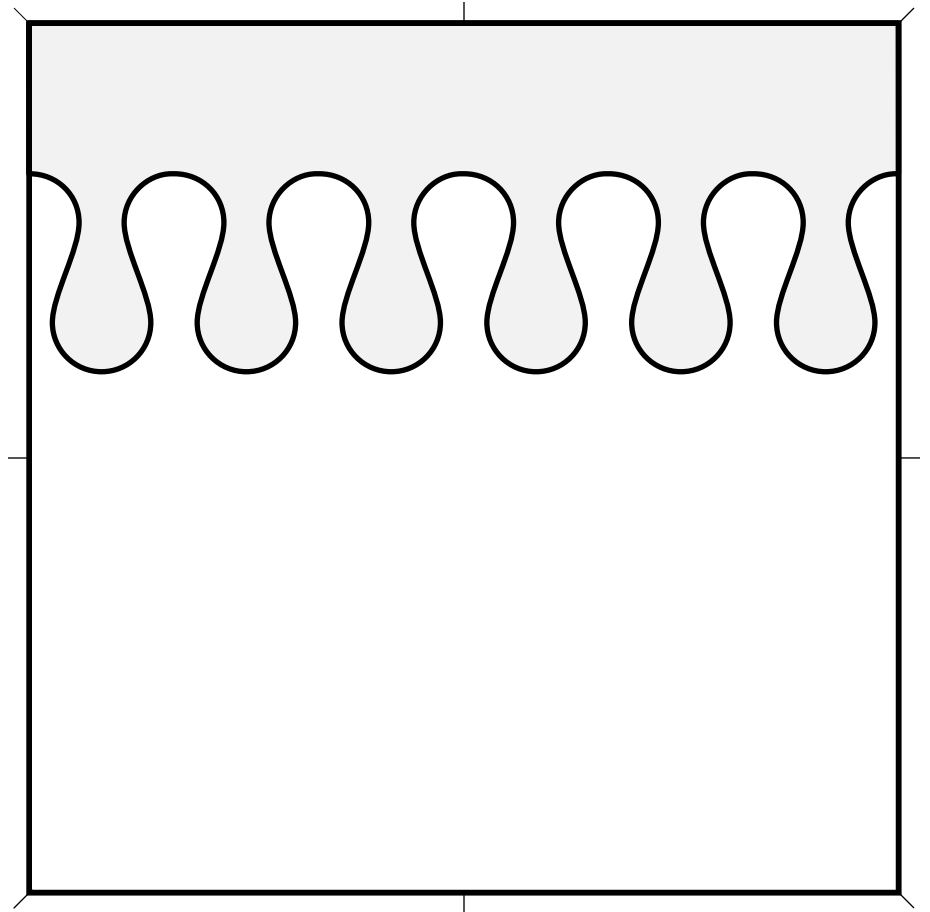
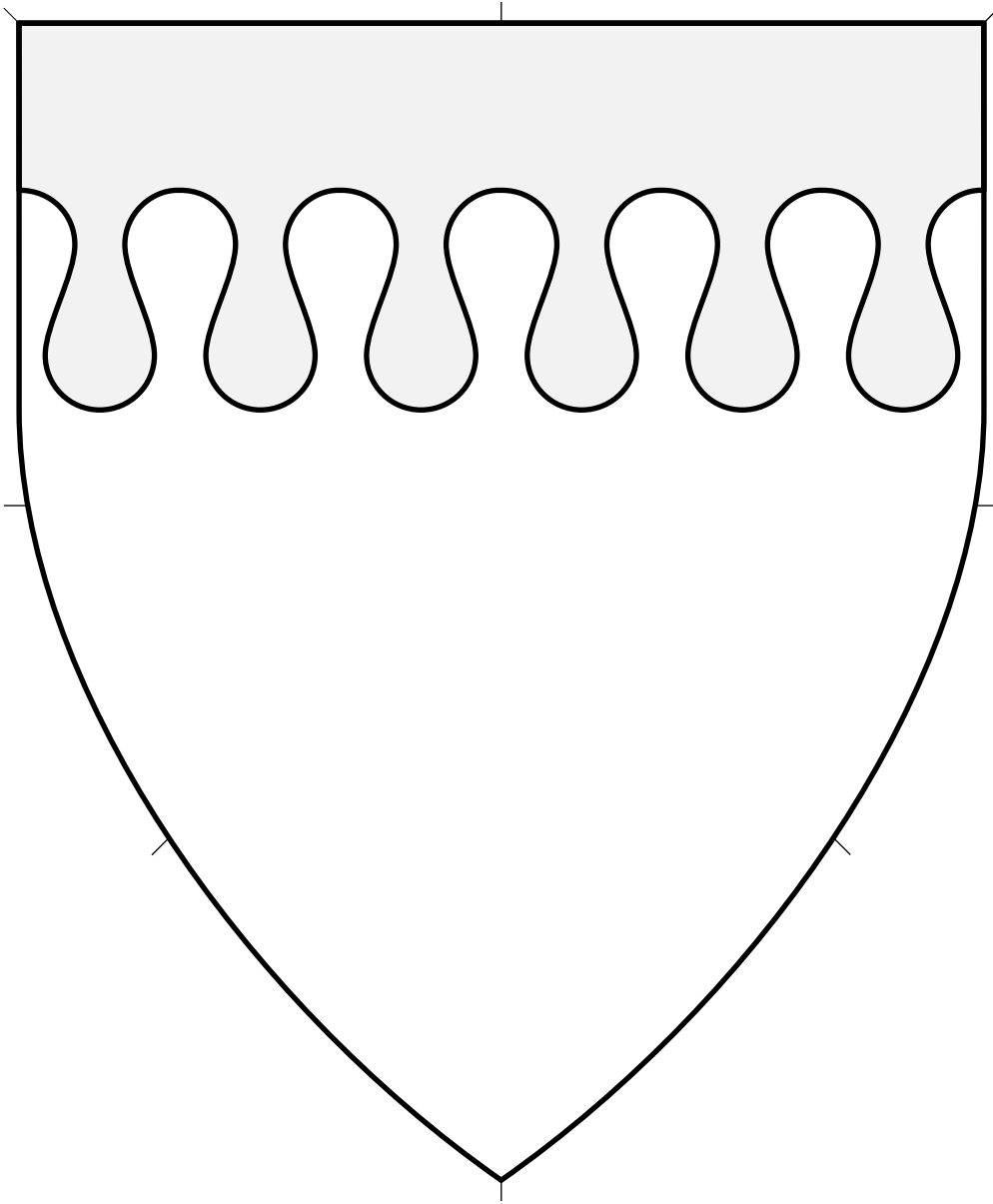

Peripheral ordinary.

Chief Nebuly (5) 4.311

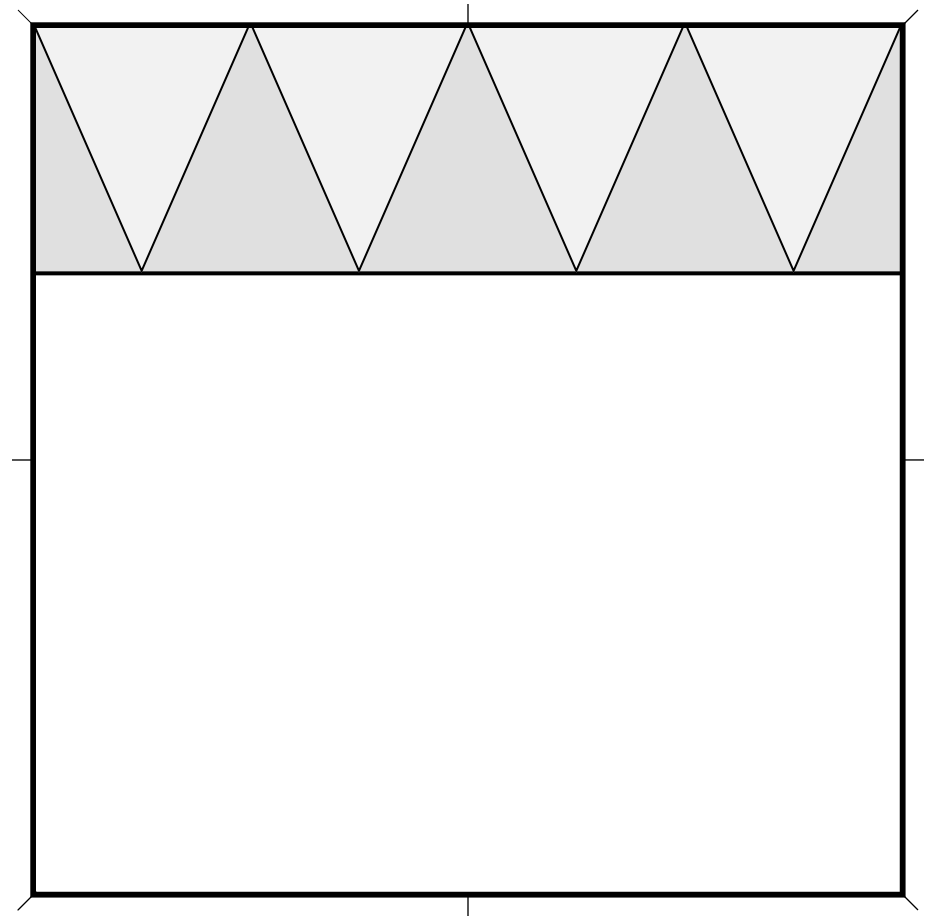
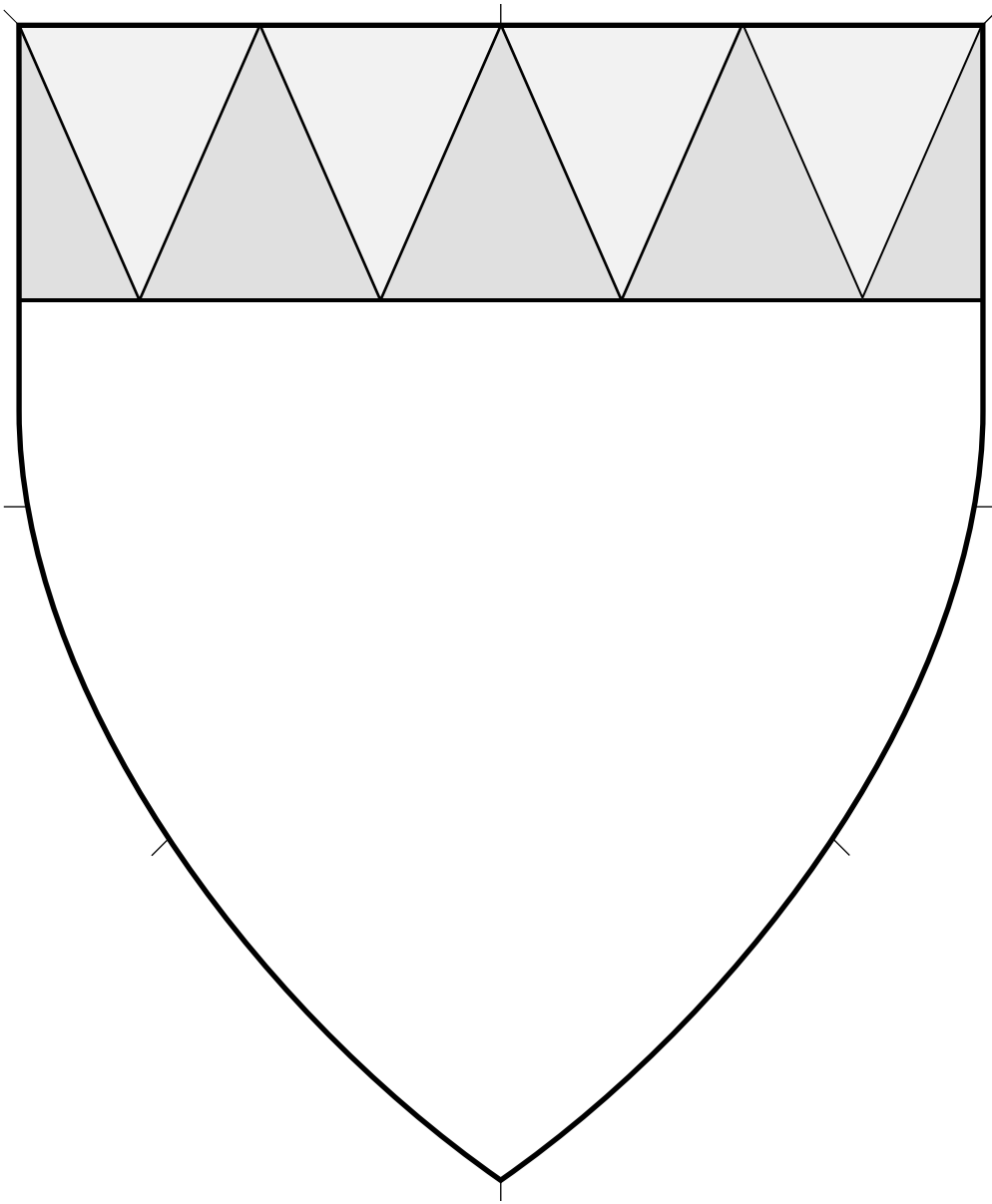

Peripheral ordinary.

Source: Armorial Lorrain de la Première Moitié du XVIe Siècle.
(Page 1.) Artist unknown.

Chief Parted Indented 4.312

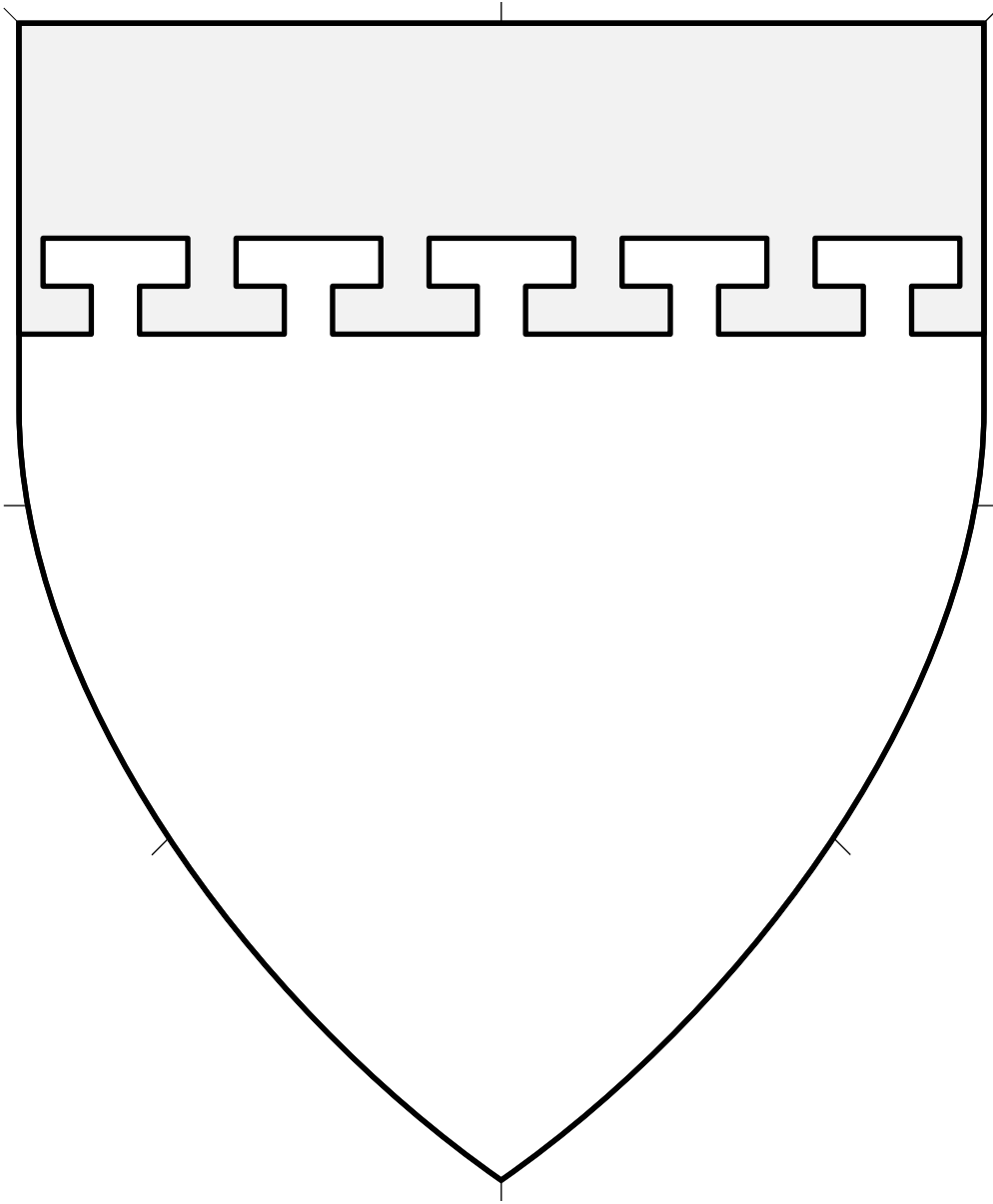

Peripheral ordinary.

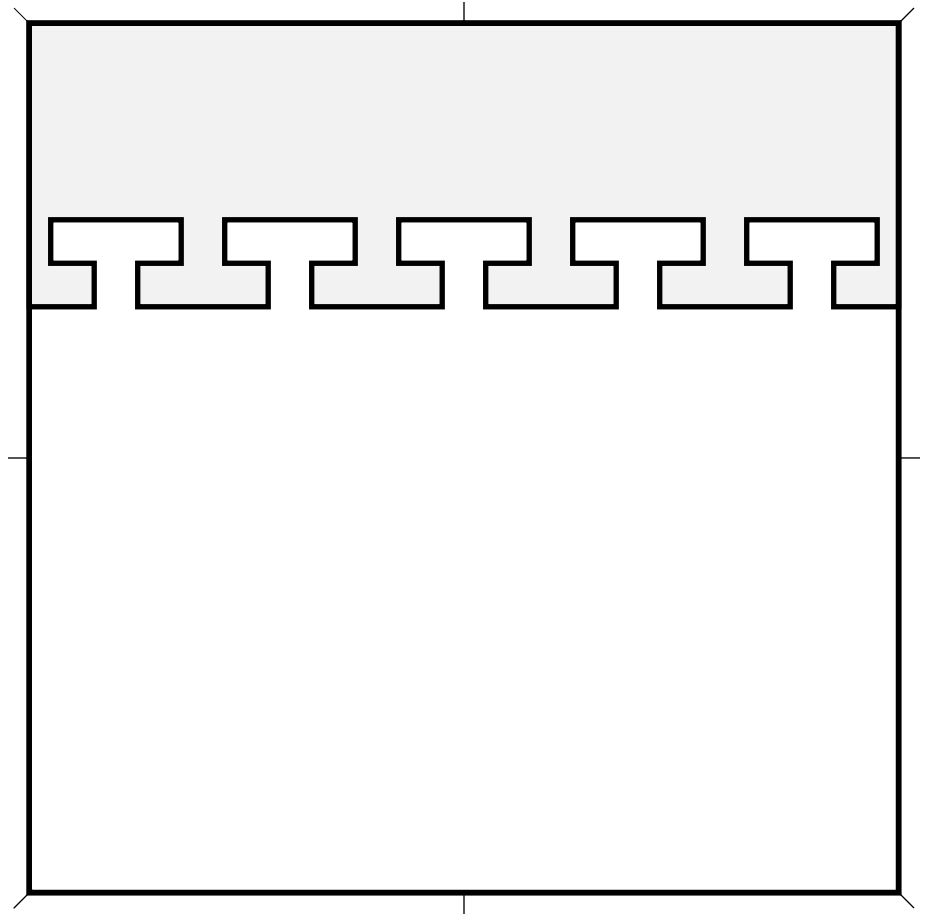

Chief Potency (1) 4.313

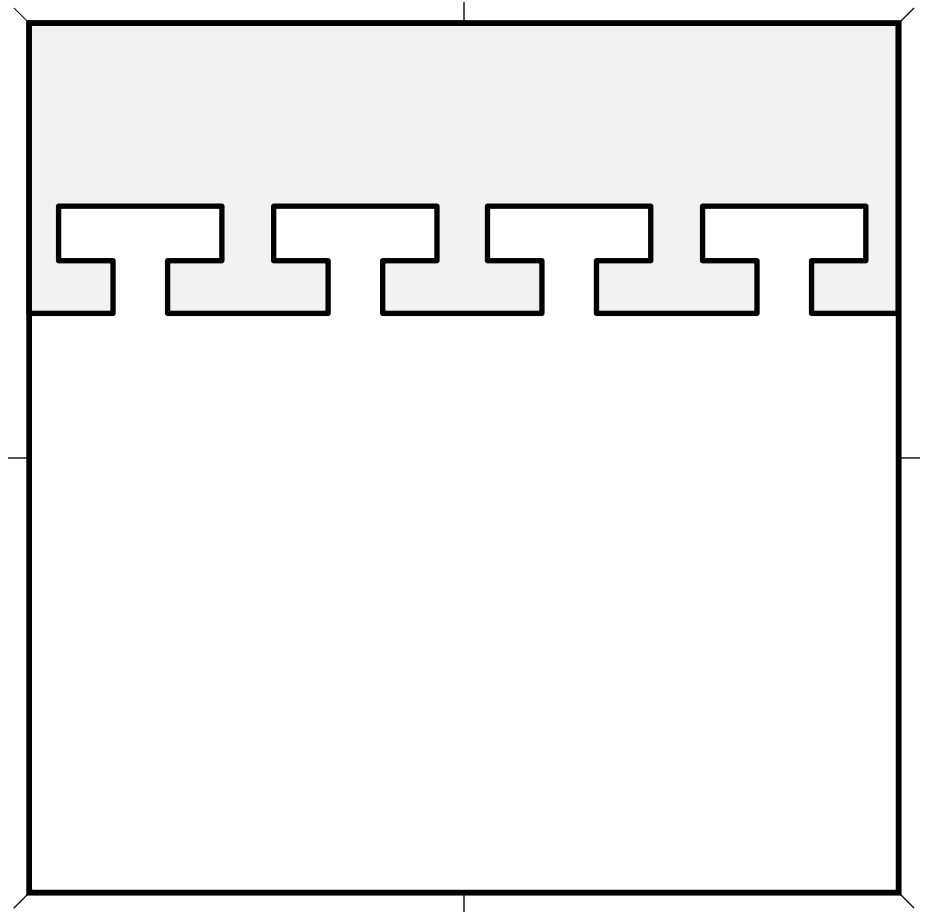
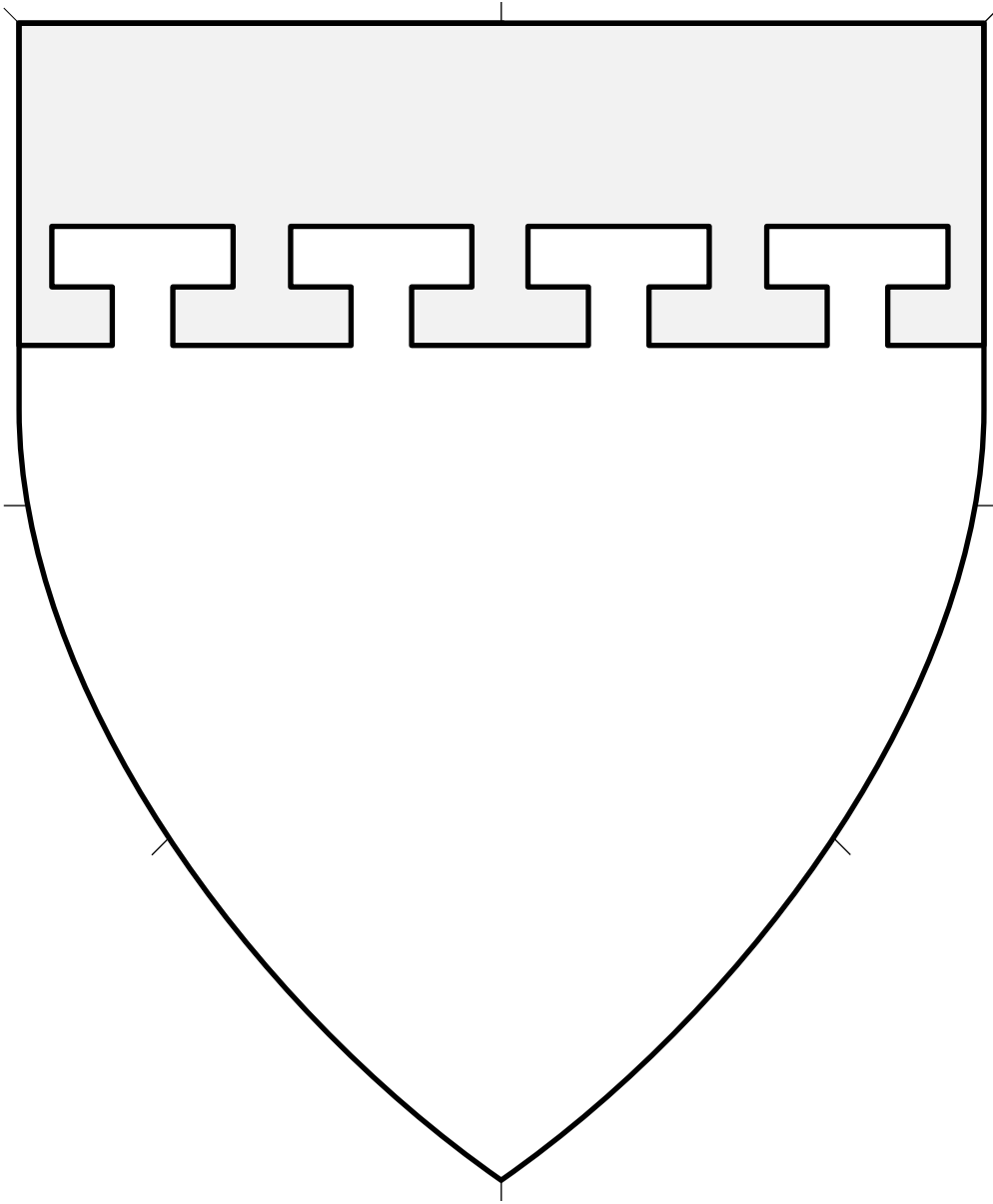

Peripheral ordinary.

Source: Viking Answer Lady SVG Images For Heraldry.
Artist: Gunnvôr silfrahárr. Adapted by Mathghamhain Ua Ruadháin.

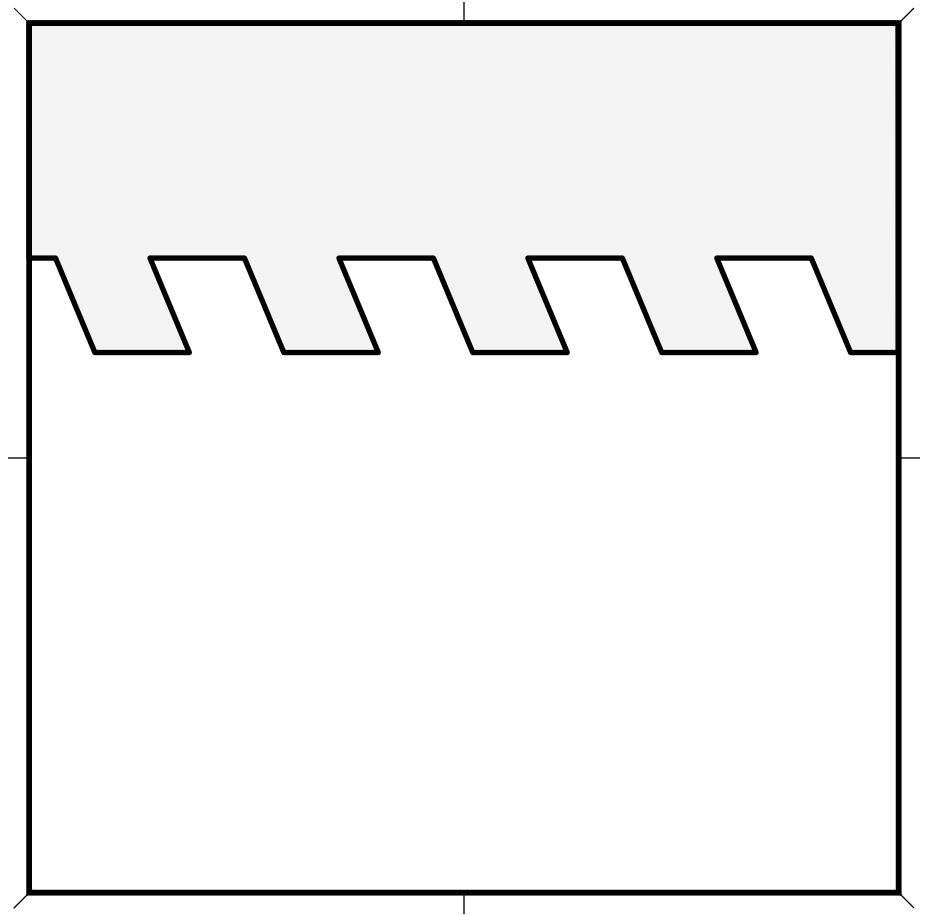
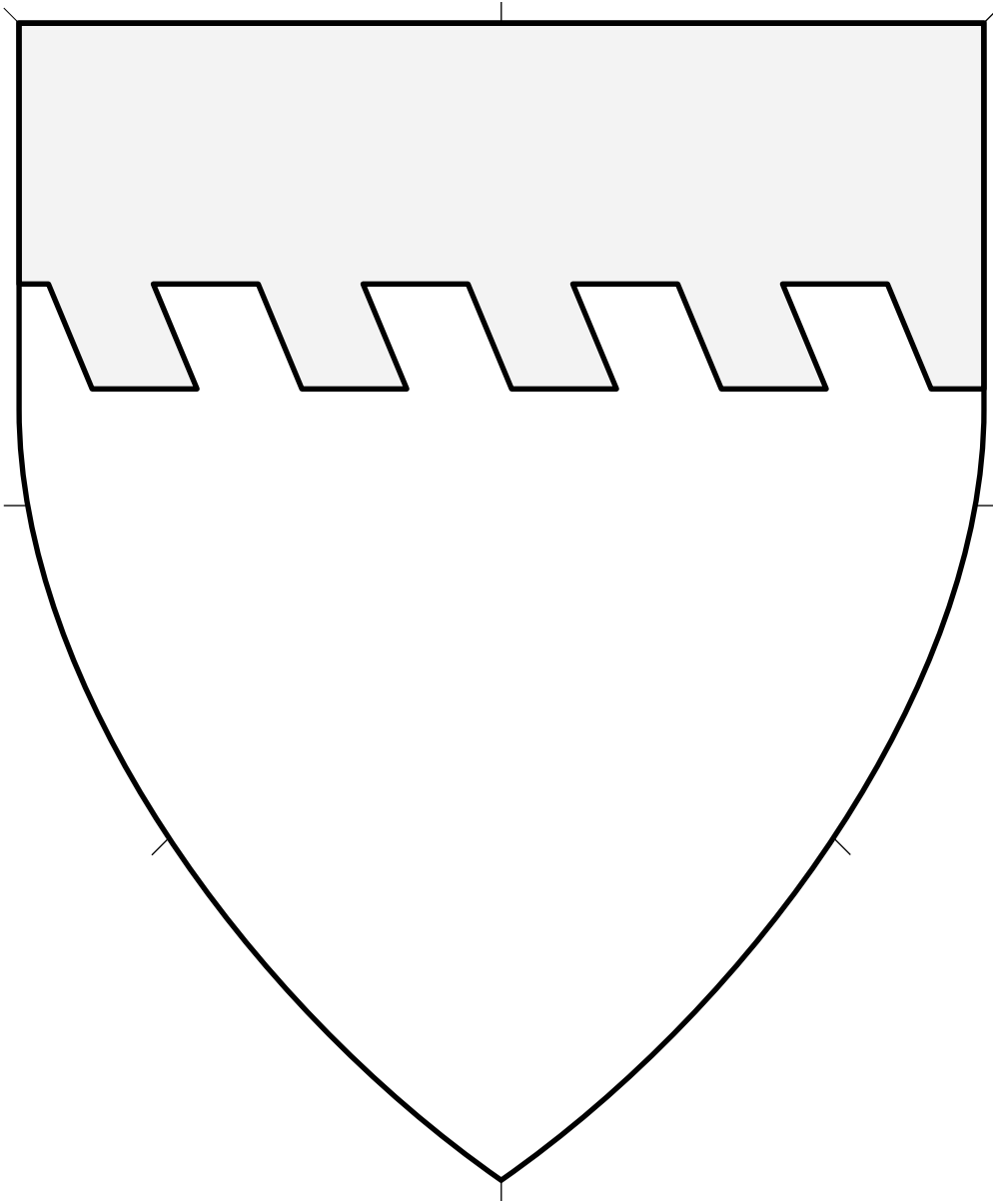

Peripheral ordinary.
Artist: Vémundr Syvursson.

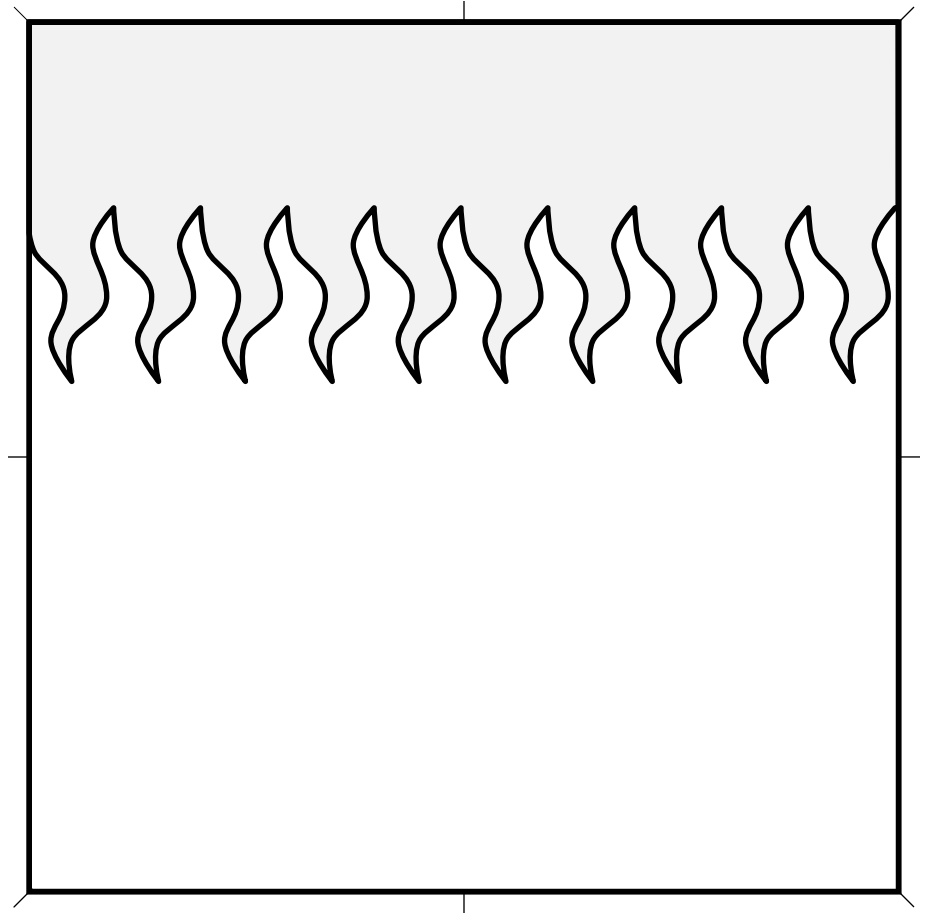
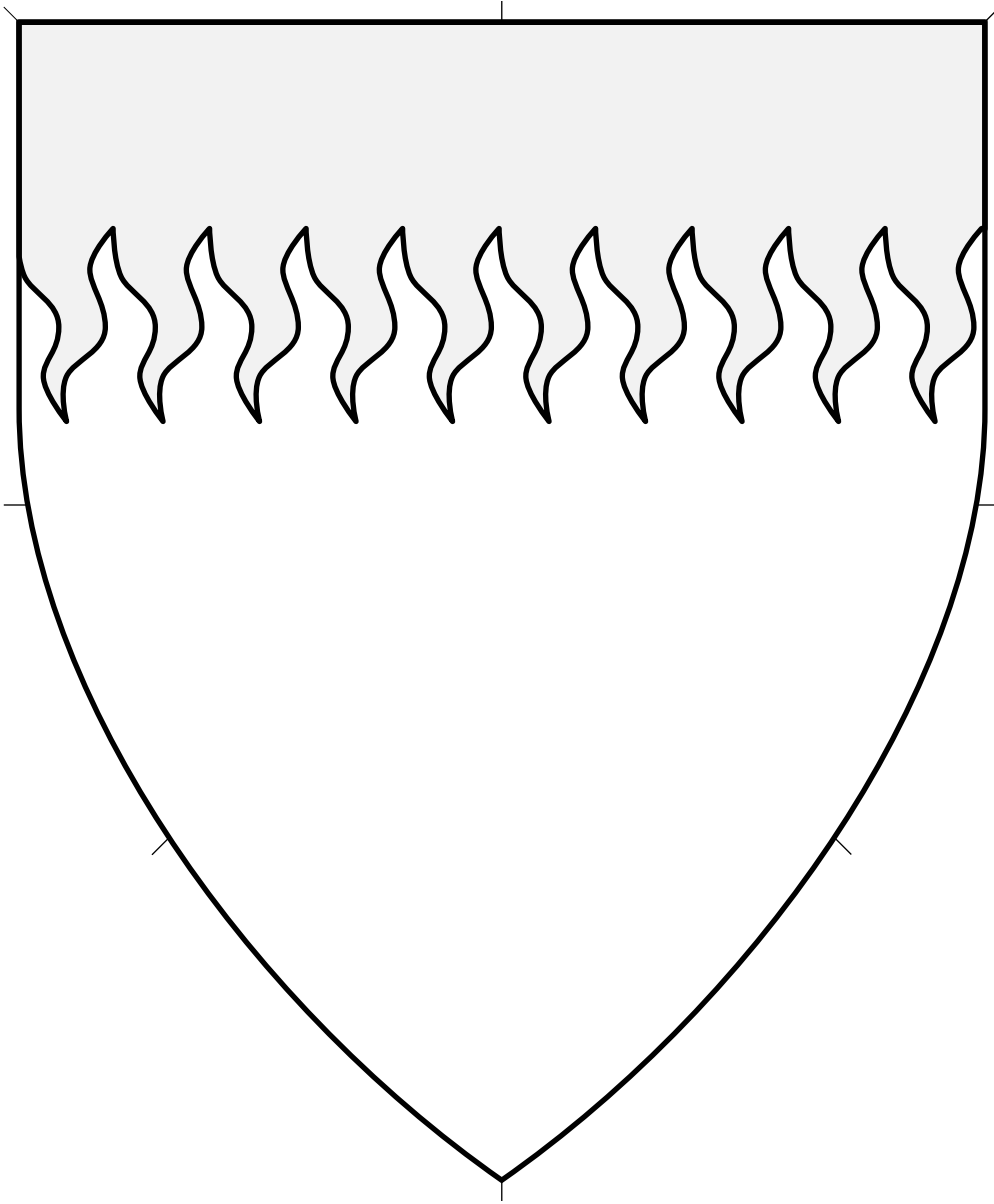

Peripheral ordinary.
Artist: Vémundr Syvursson.

Chief Rayonny (1) 4.316

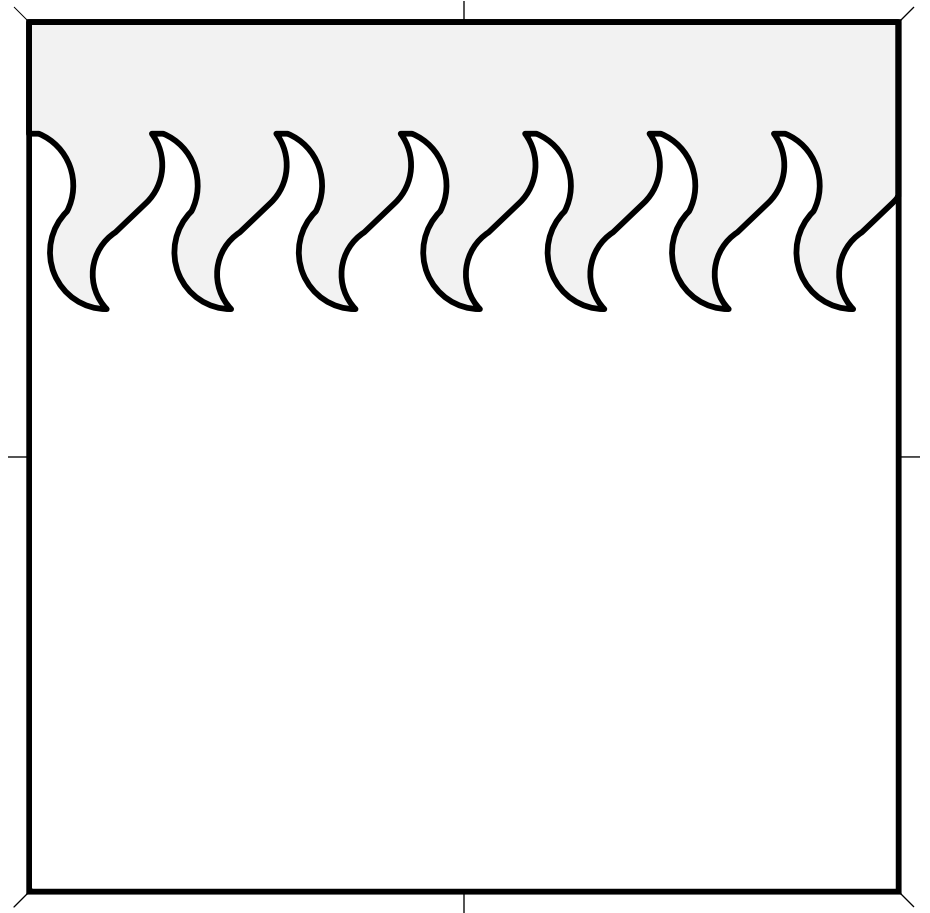
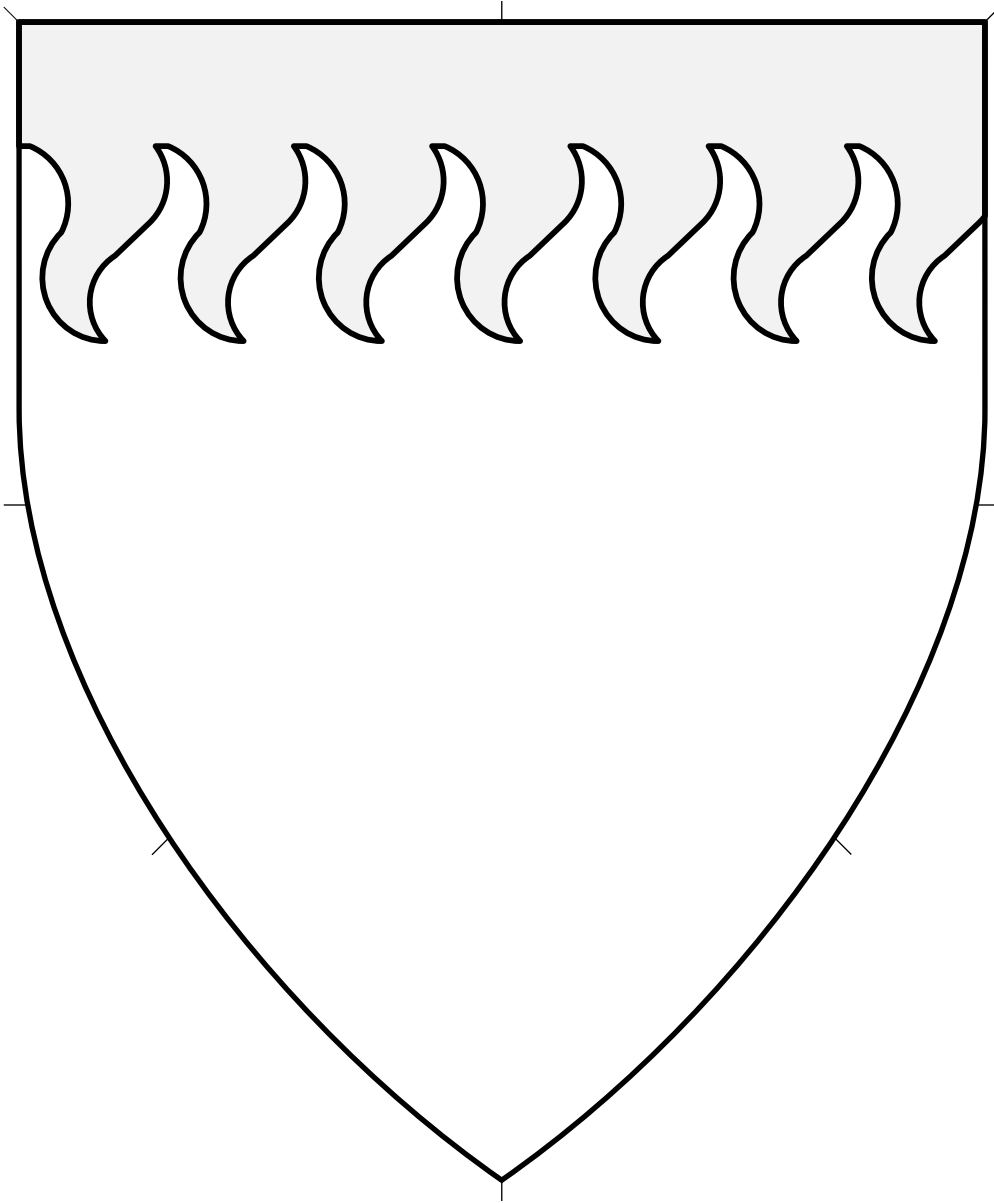

Peripheral ordinary.

Source: Viking Answer Lady SVG Images For Heraldry.
Artist: Gunnvôr silfrahárr. Adapted by Mathghamhain Ua Ruadháin.

Chief Rayonny (2) 4.317

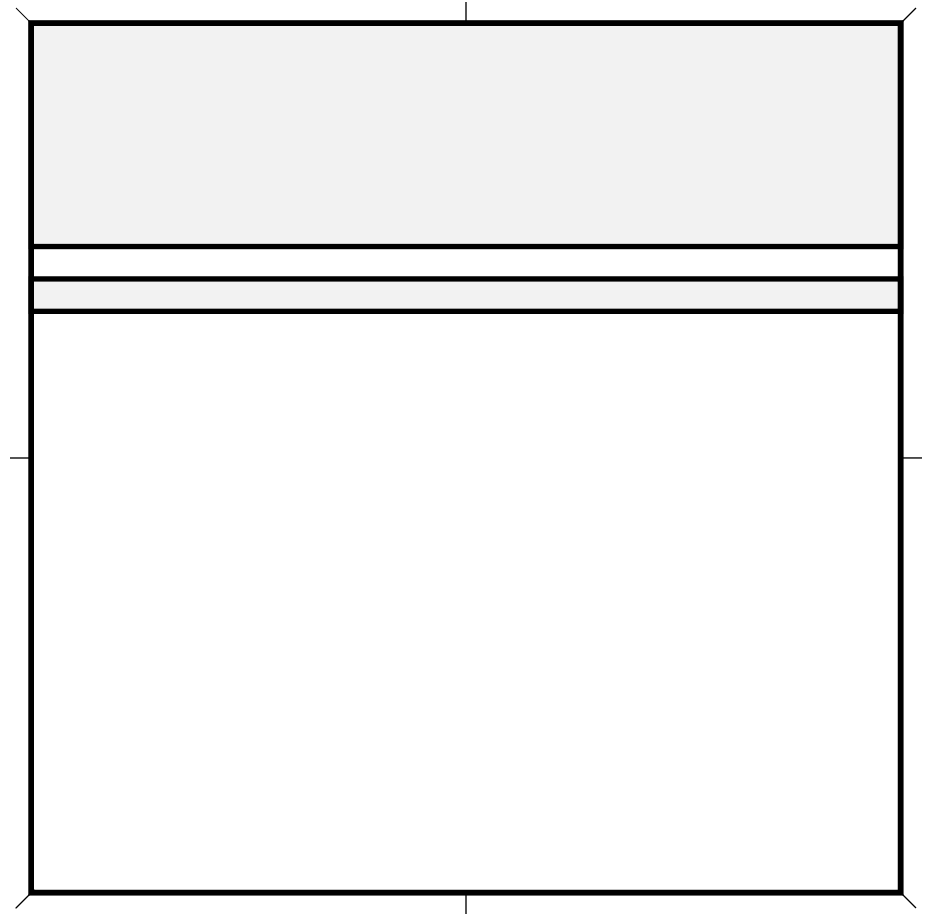
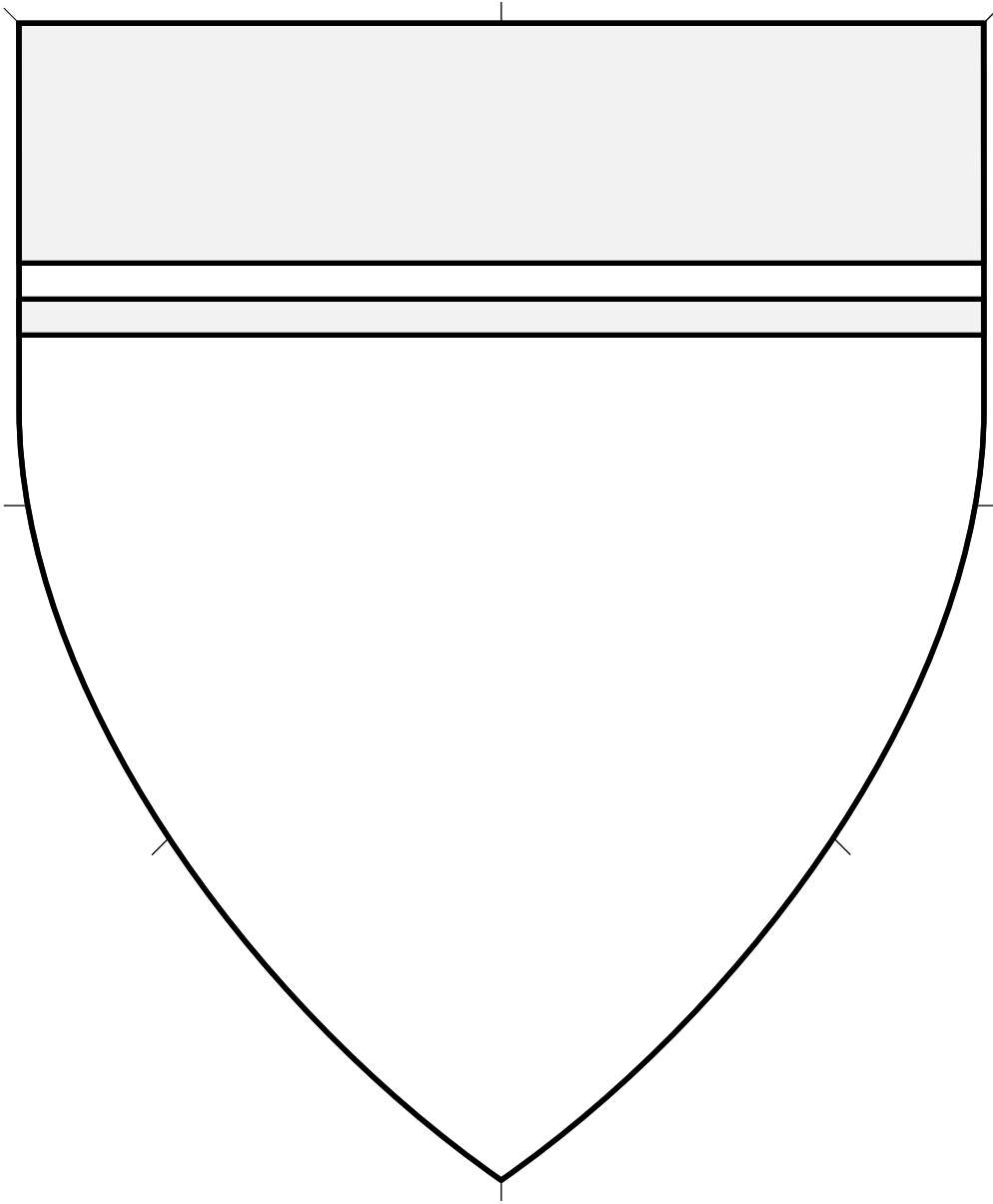

Peripheral ordinary.

Chief Surmounted by a Fillet Counterchanged 4.318

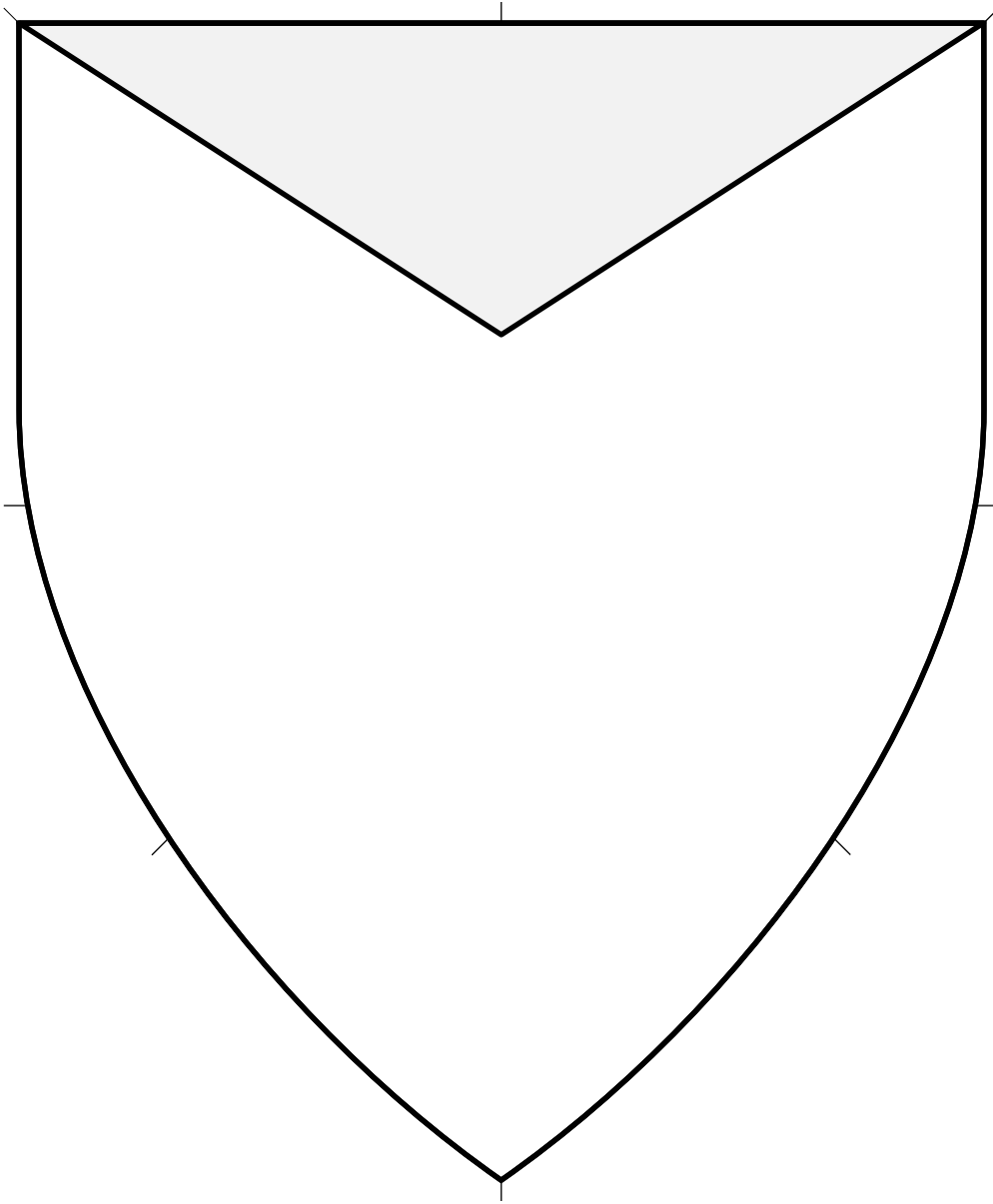

Peripheral ordinary.

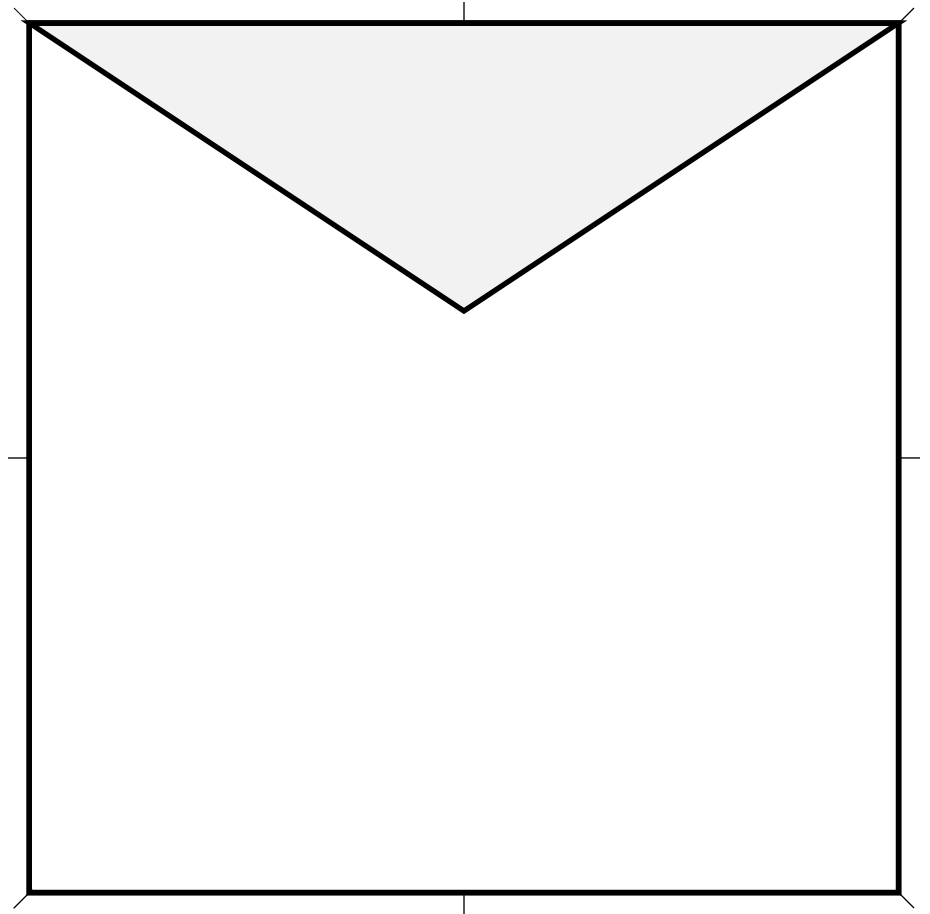

Chief Triangular 4.319

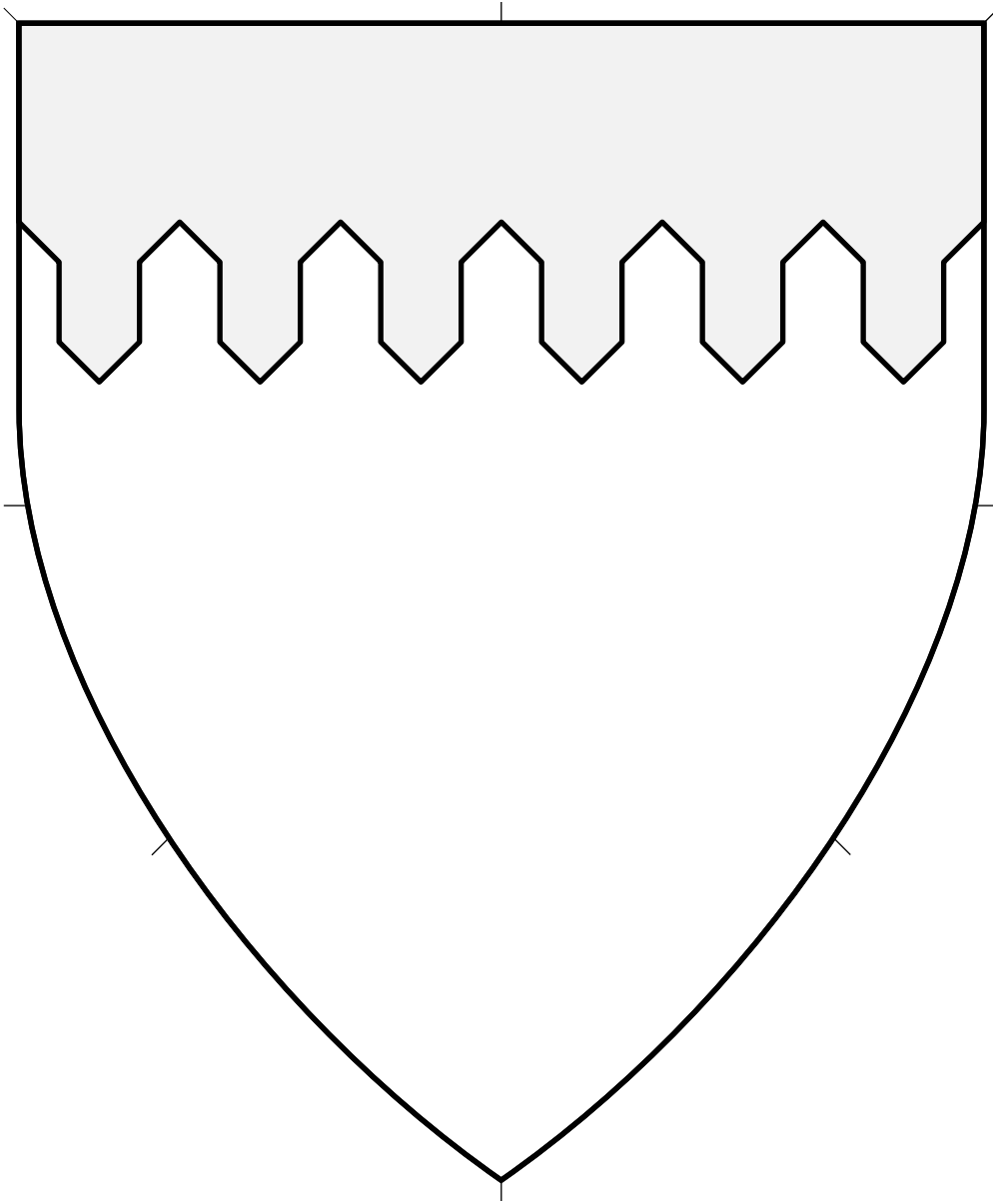

Peripheral ordinary.

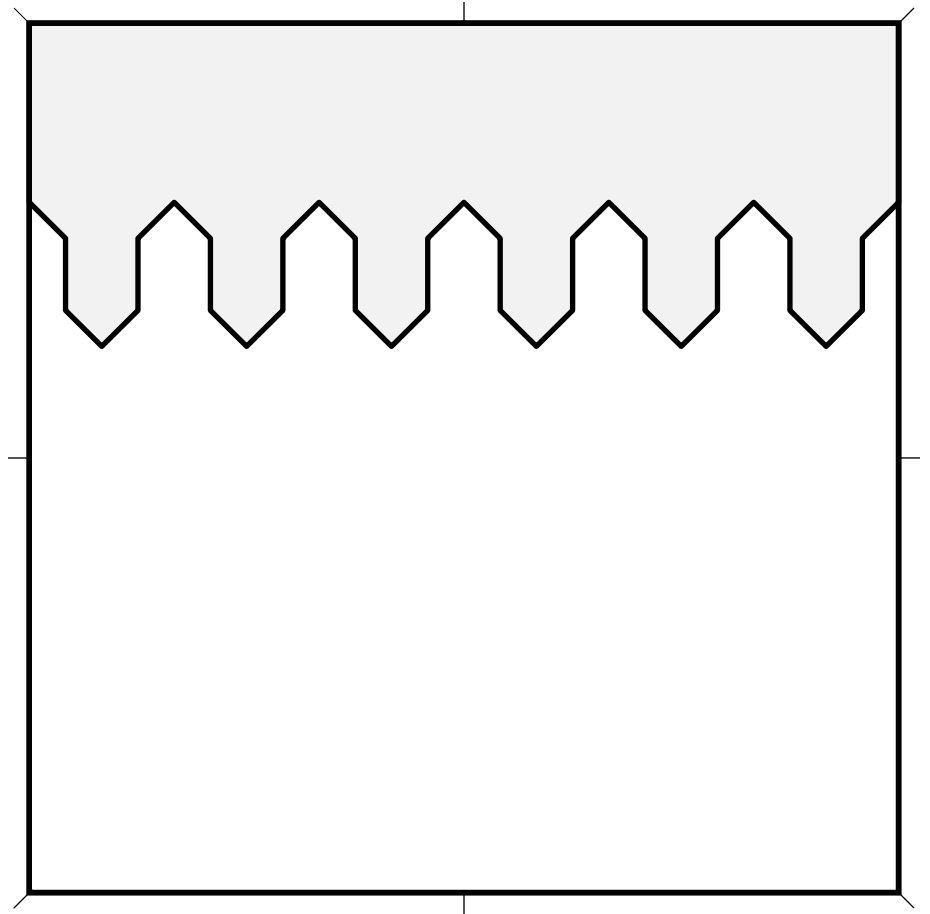

Chief Urdy (1) • 4.320

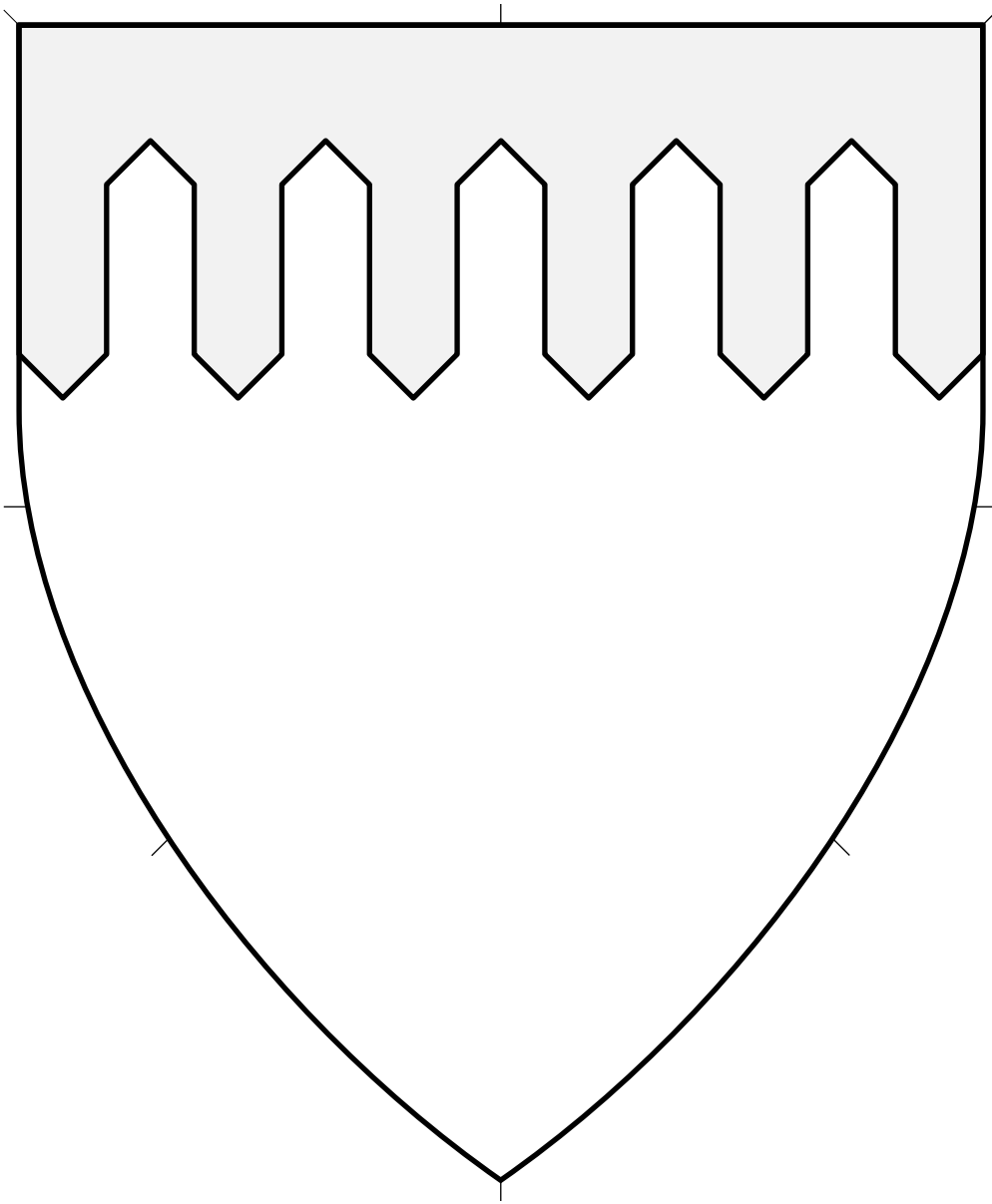

Peripheral ordinary.

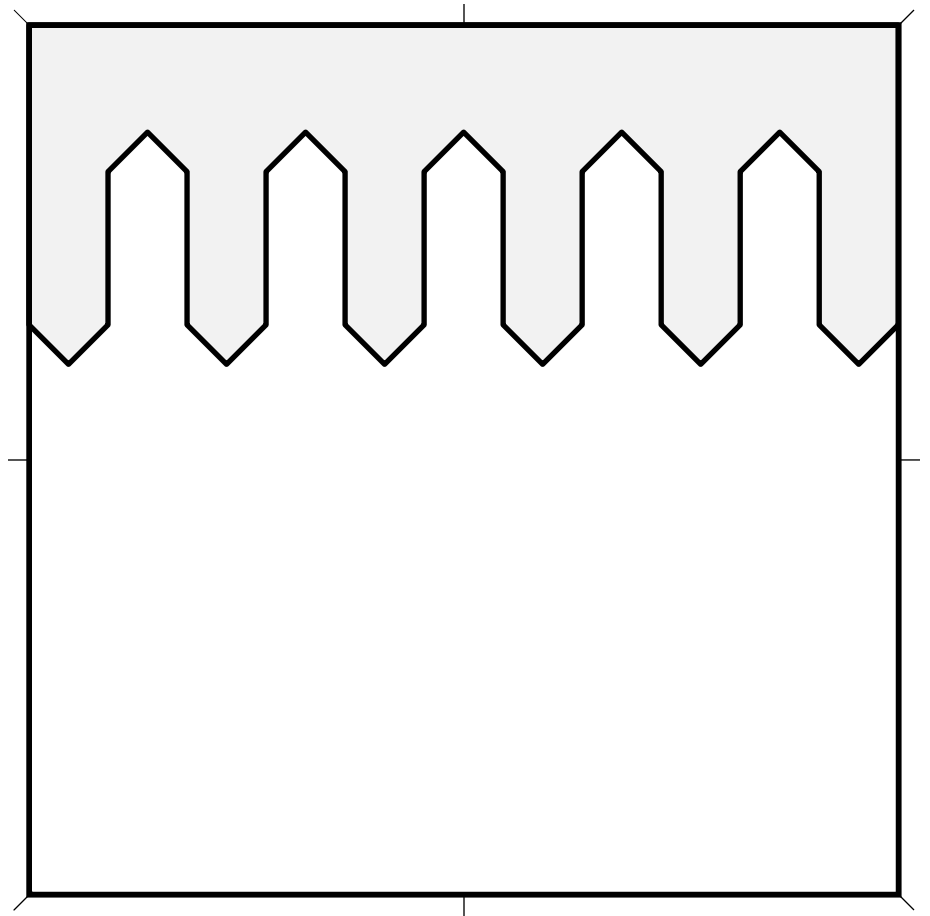

Chief Urdy (2) 4.321

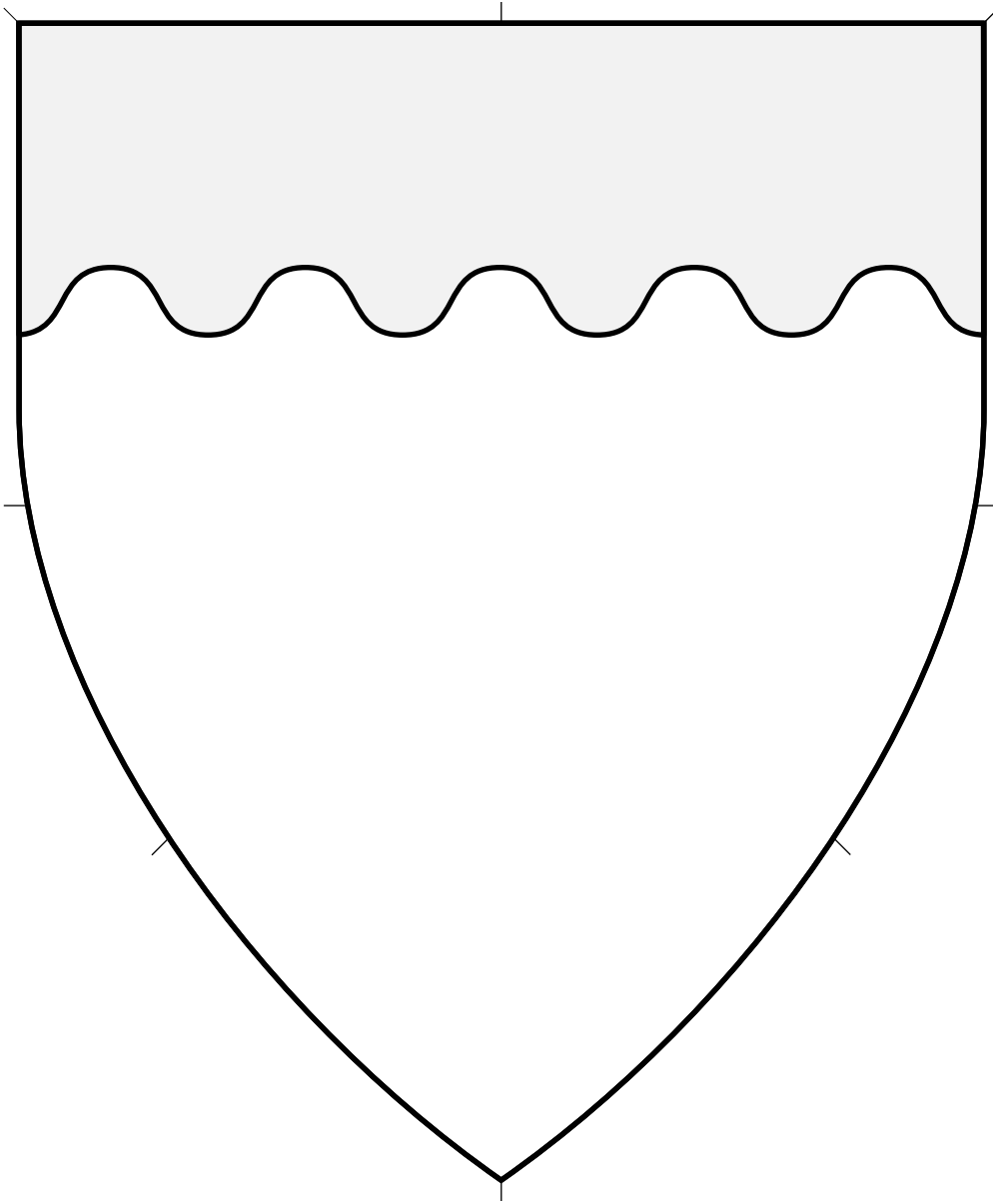

Peripheral ordinary.

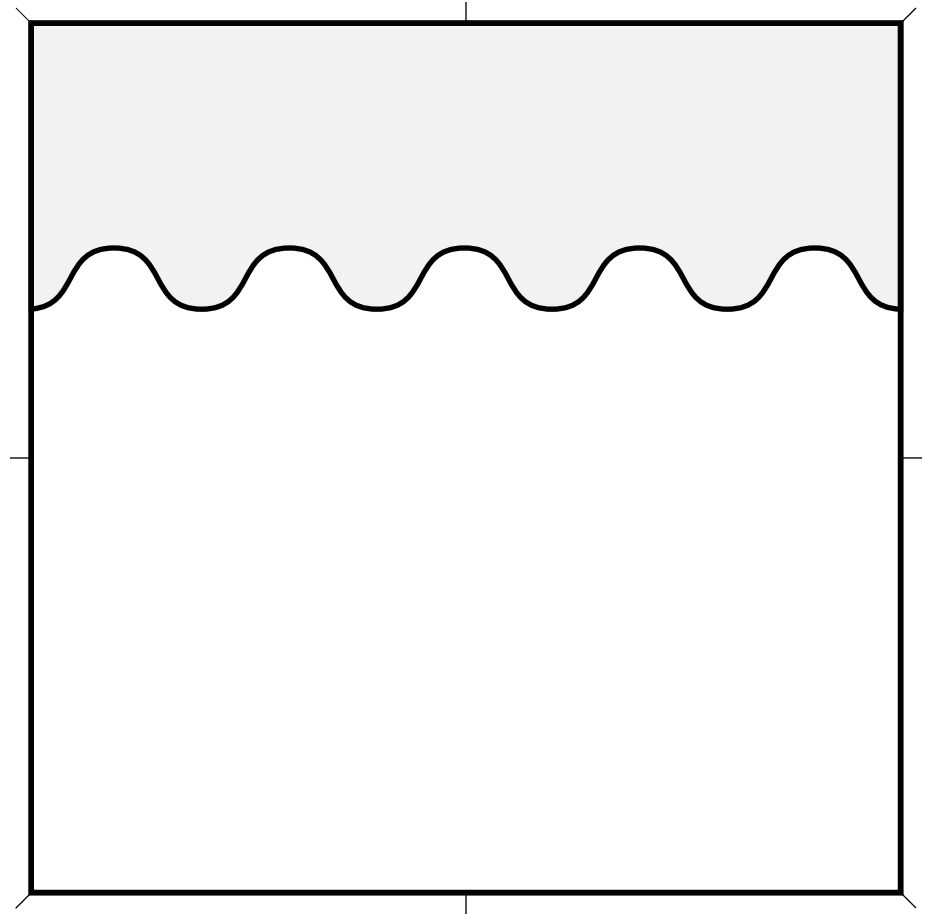

Chief Wavy (1) 4.322

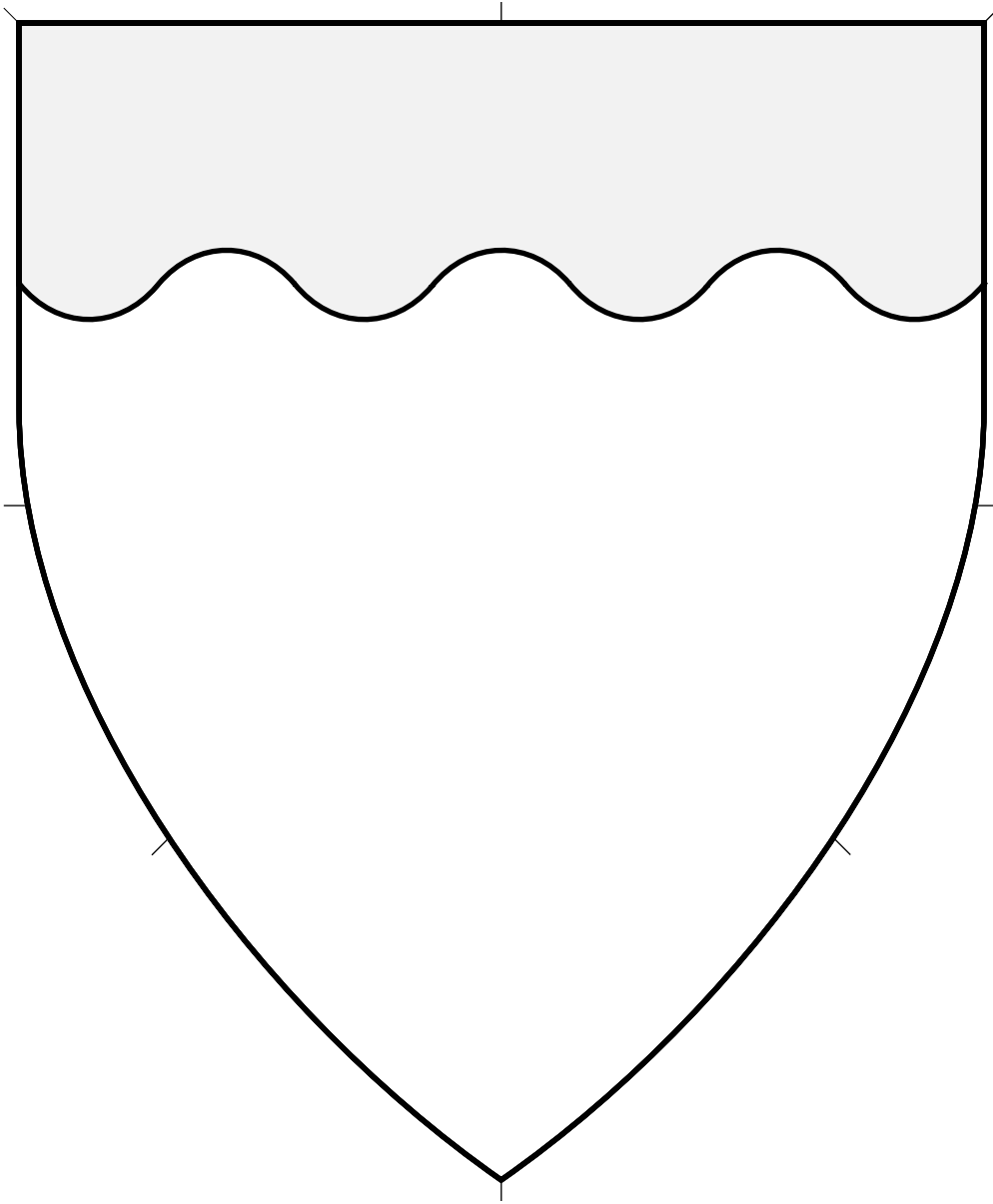

Peripheral ordinary.

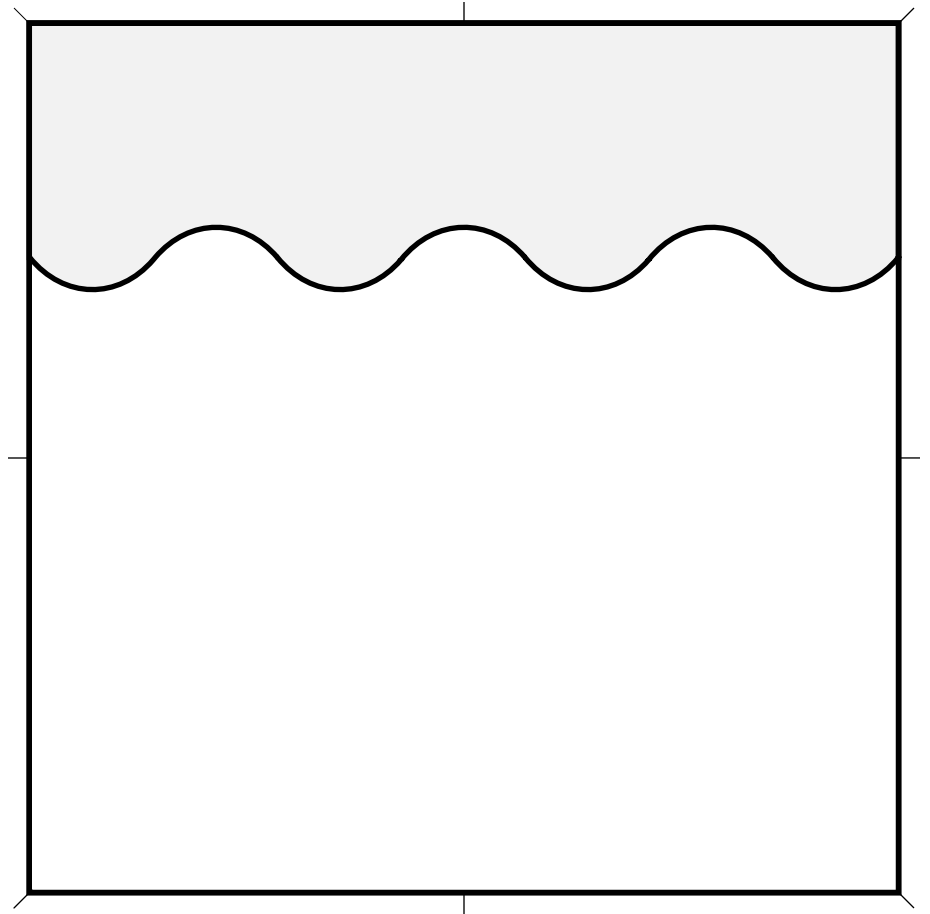

Chief Wavy (2) 4.323

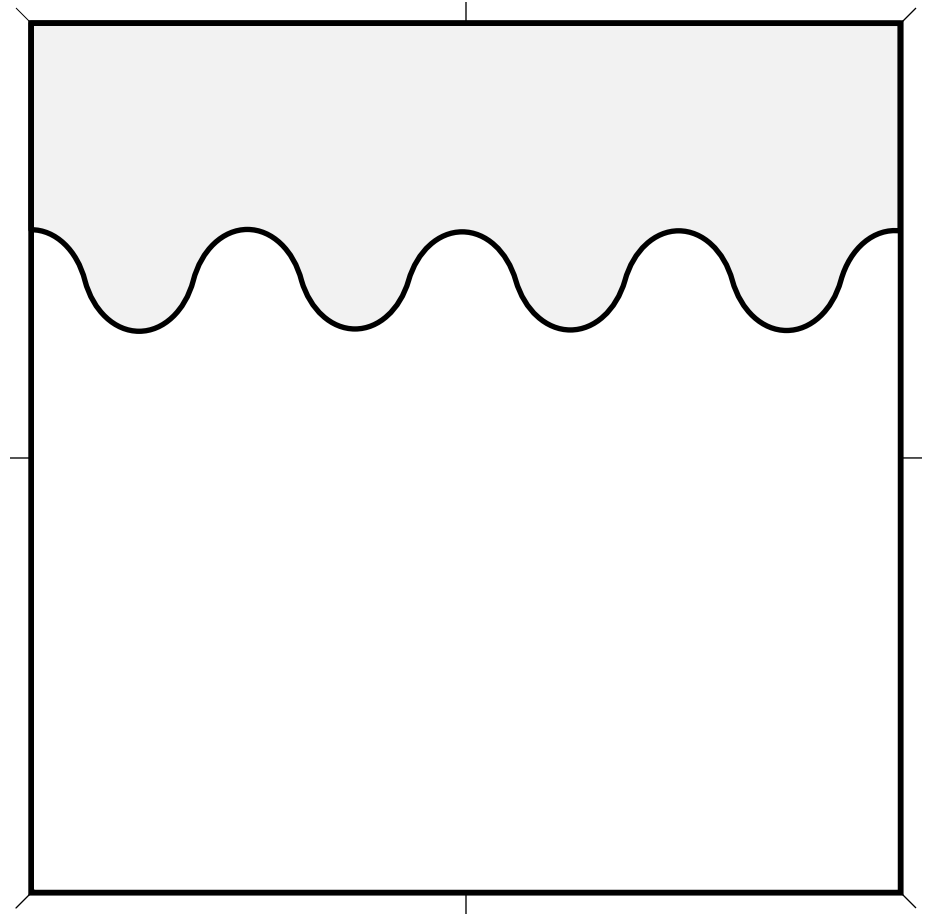
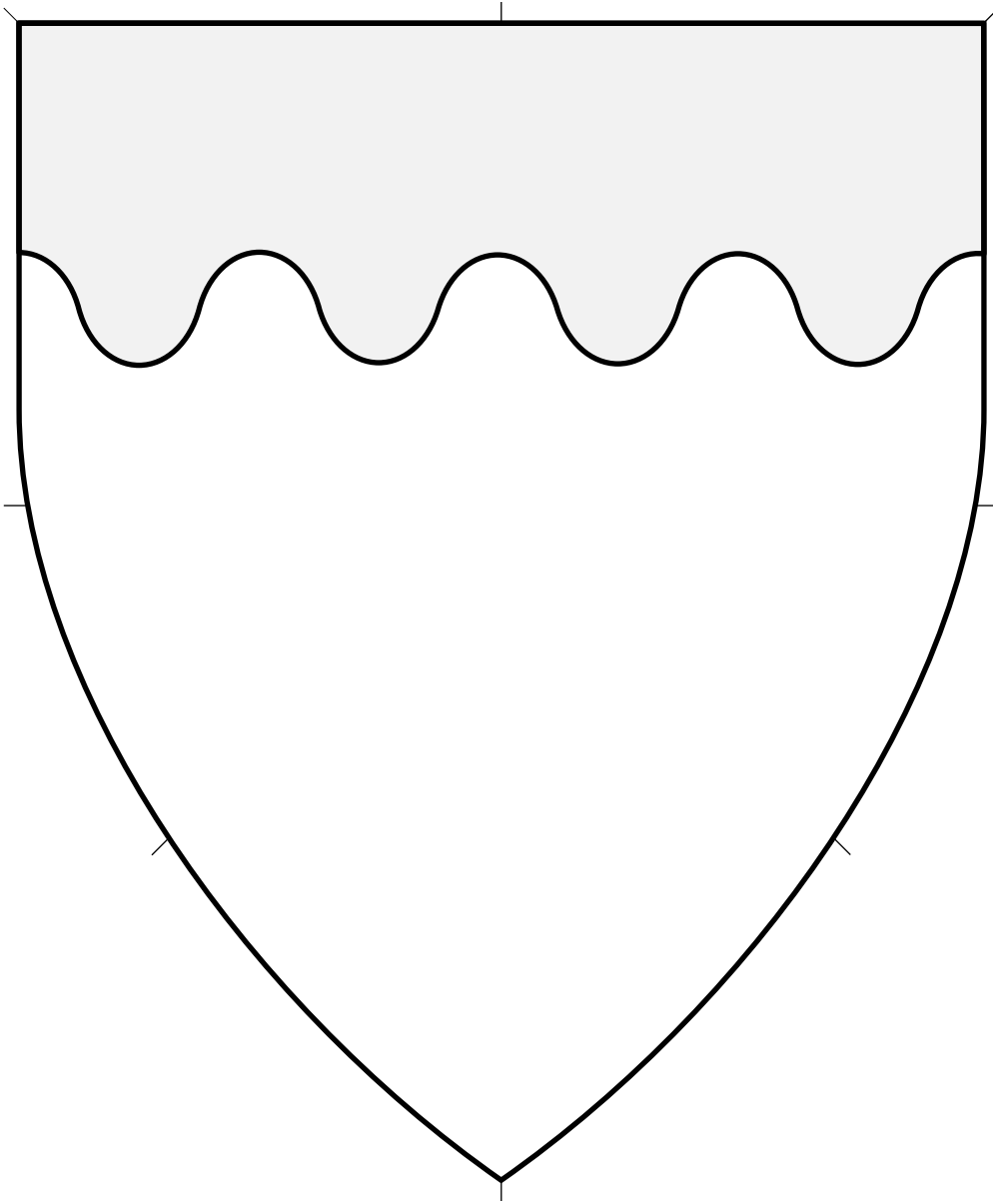

Peripheral ordinary.

Source: Viking Answer Lady SVG Images For Heraldry.
Artist: Gunnvôr silfrahárr. Adapted by Mathghamhain Ua Ruadháin.

Chief Wavy (3) 4.324

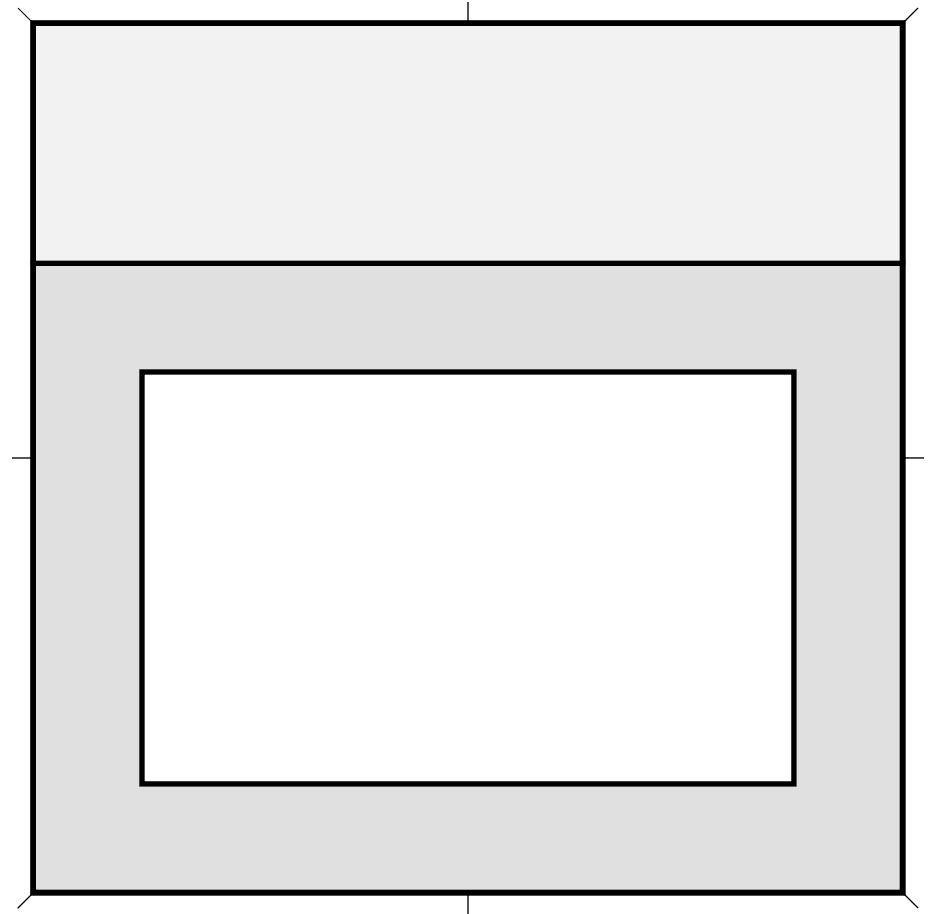
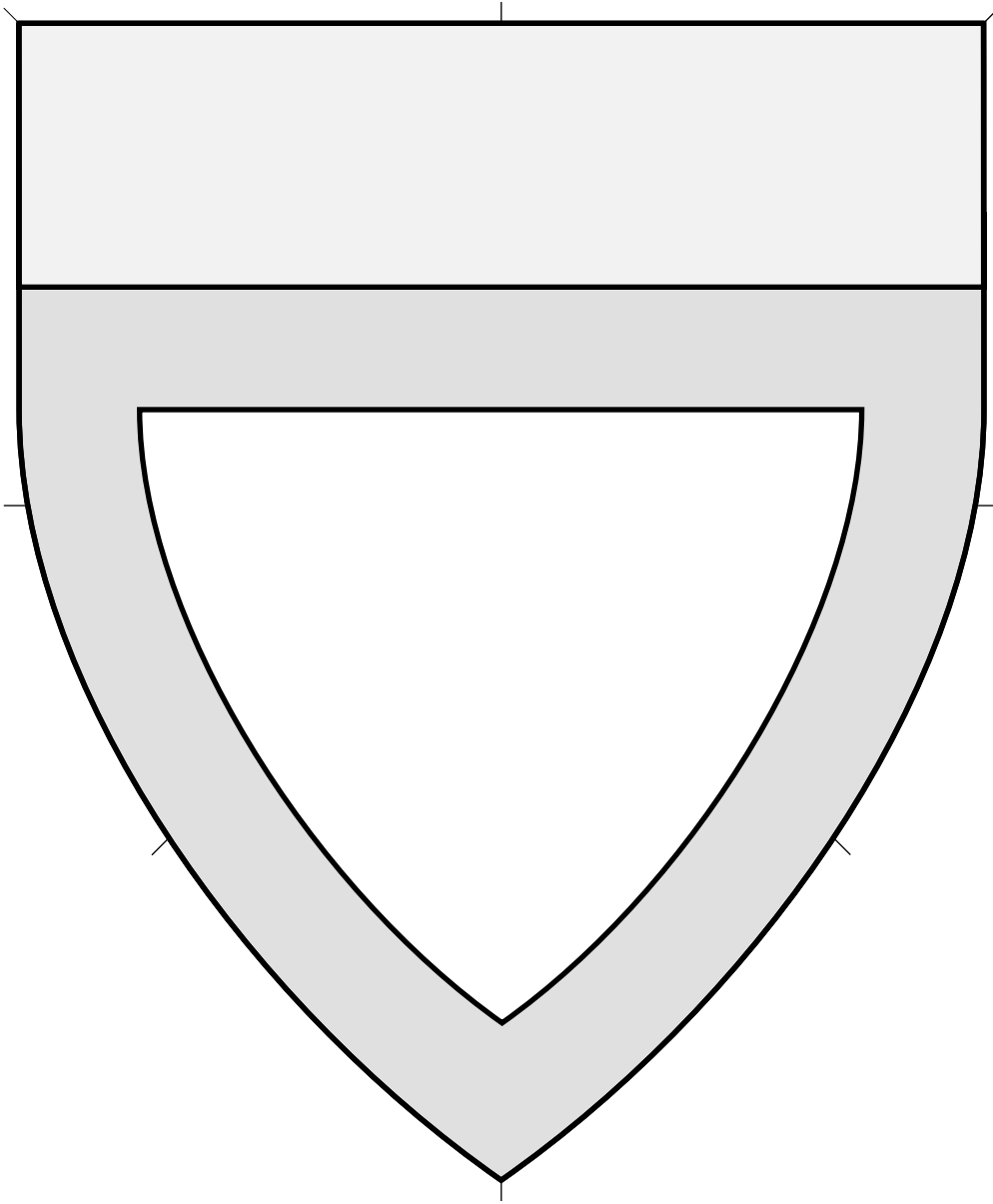

Peripheral ordinaries.

When a chief and a bordure were combined in period, the chief occasionally appears above an attenuated field surrounded by the bordure, as shown here.

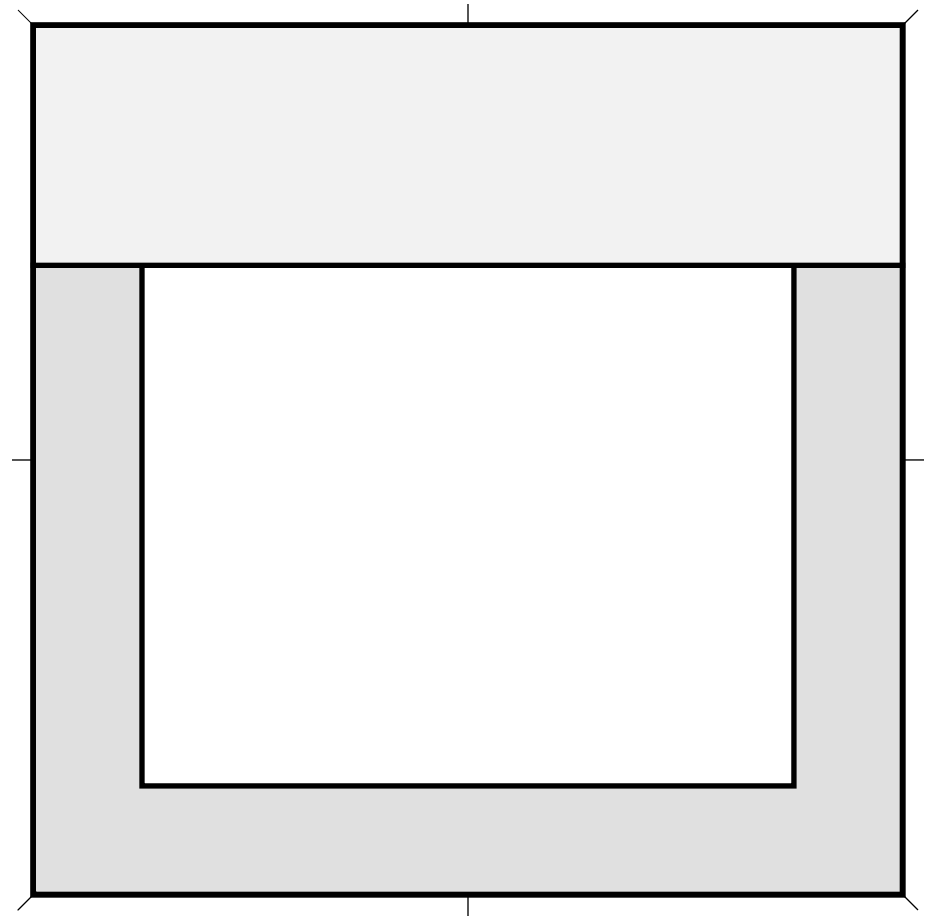
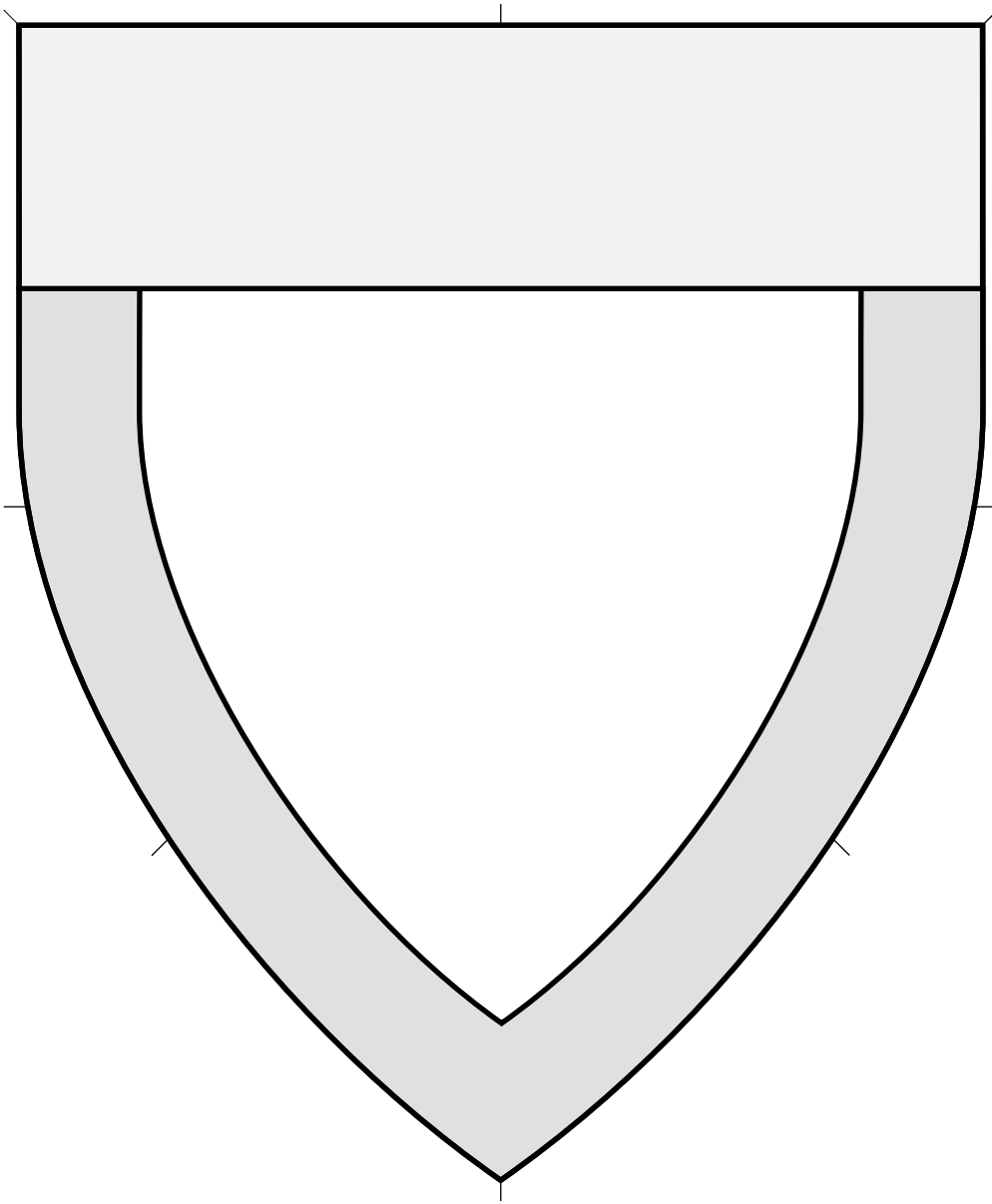

Peripheral ordinaries.

When a chief and a bordure were combined in period, the chief typically overlay the bordure, as shown here.

Chief Overall, A Bordure And 4.326

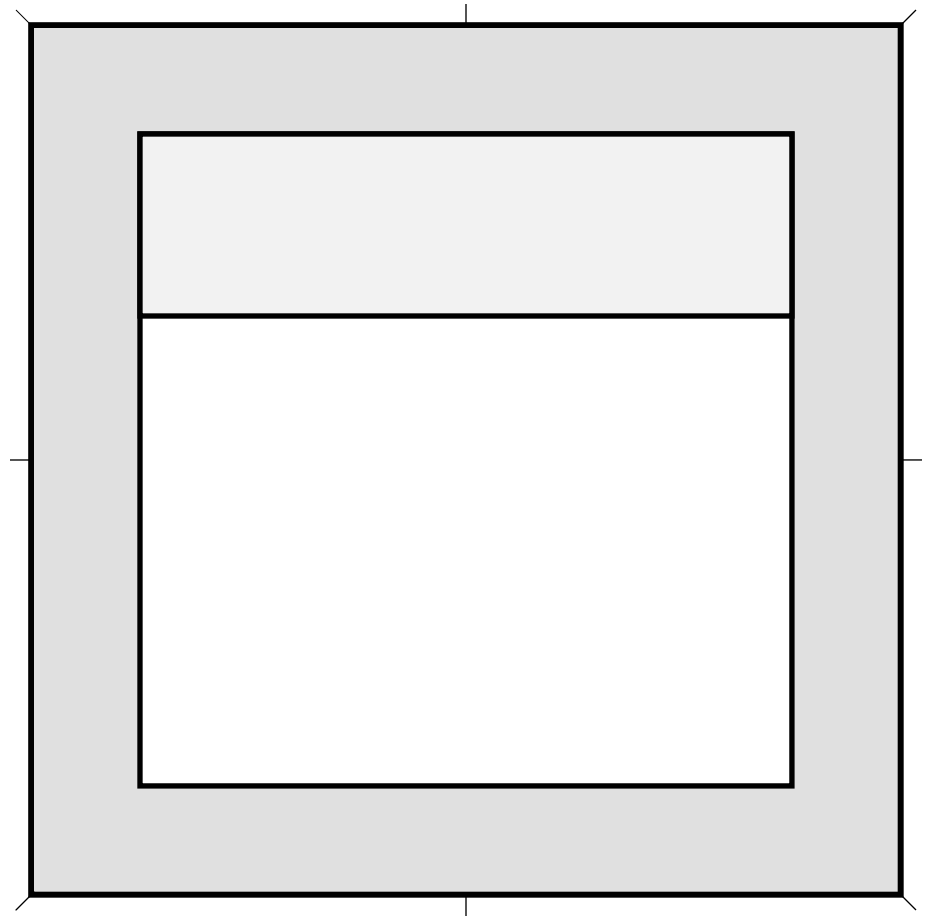
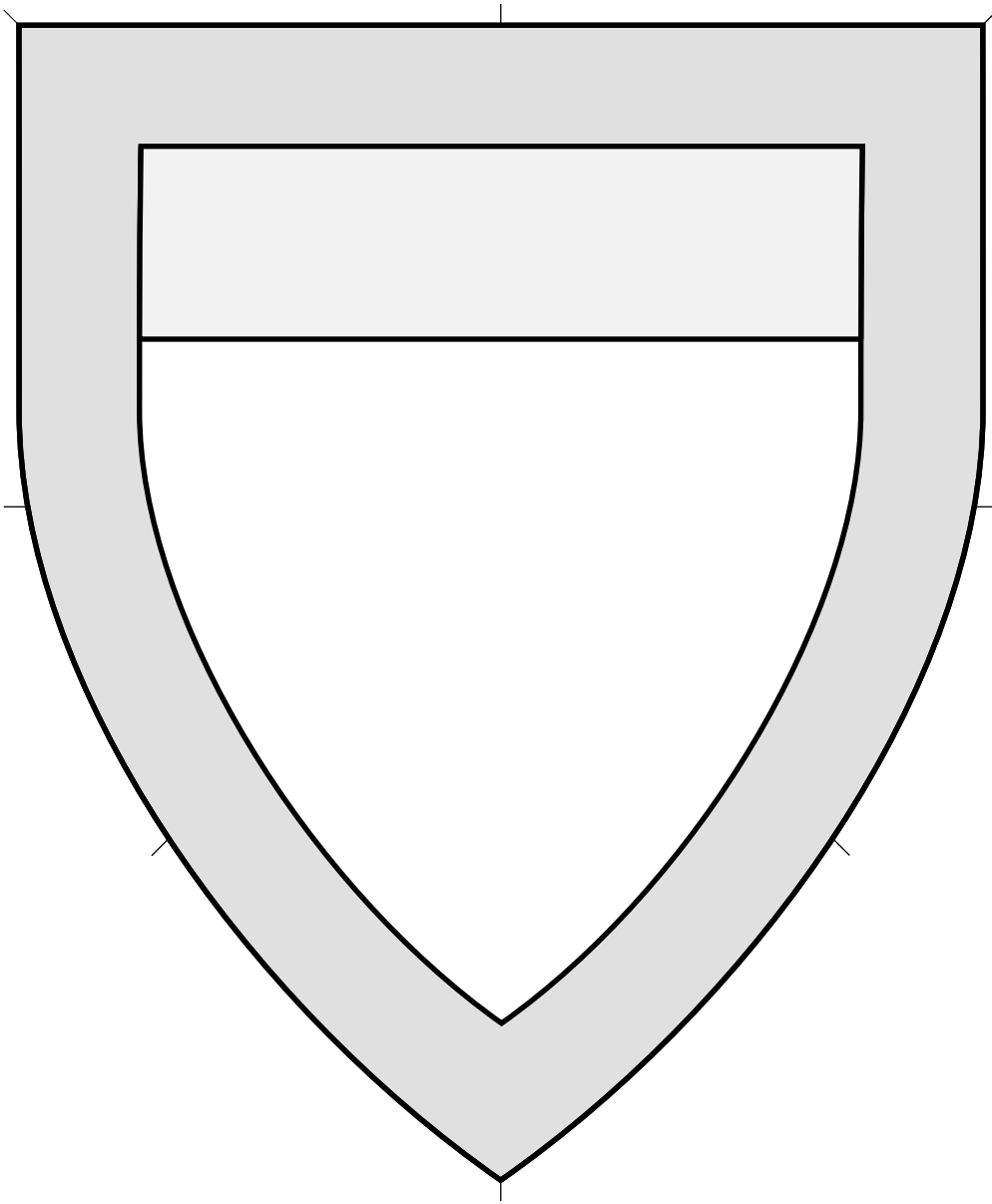

Peripheral ordinaries.

Chief And A Bordure Overall 4.327

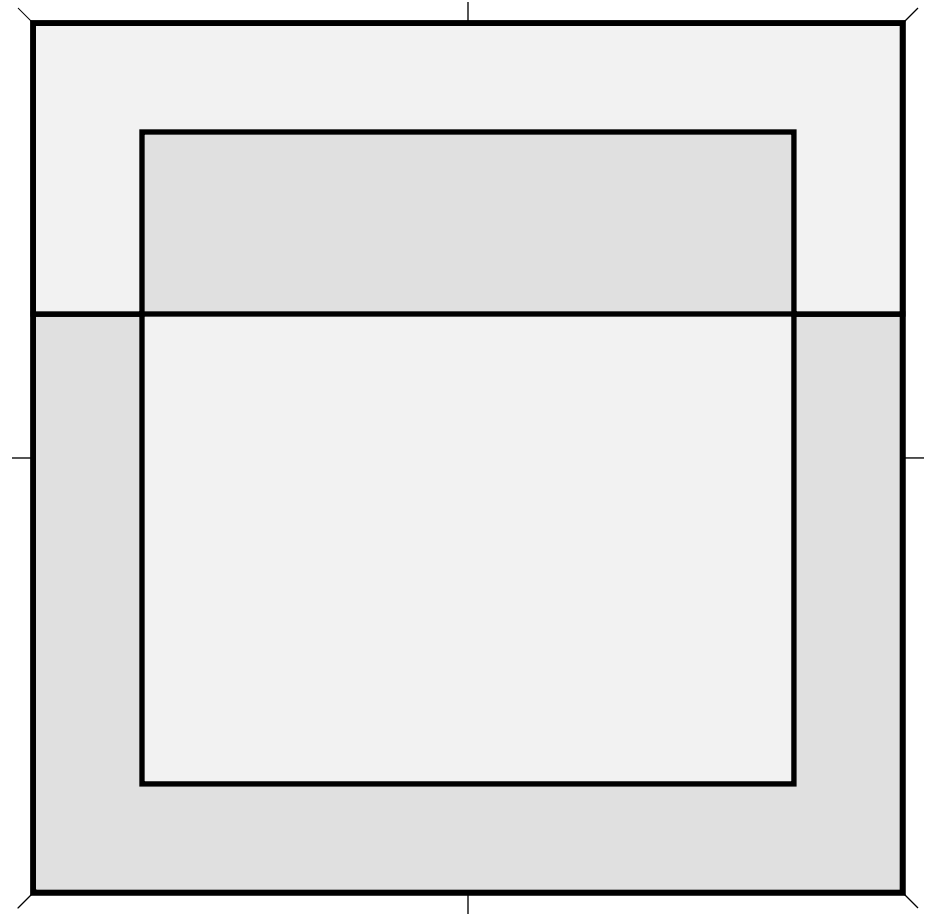
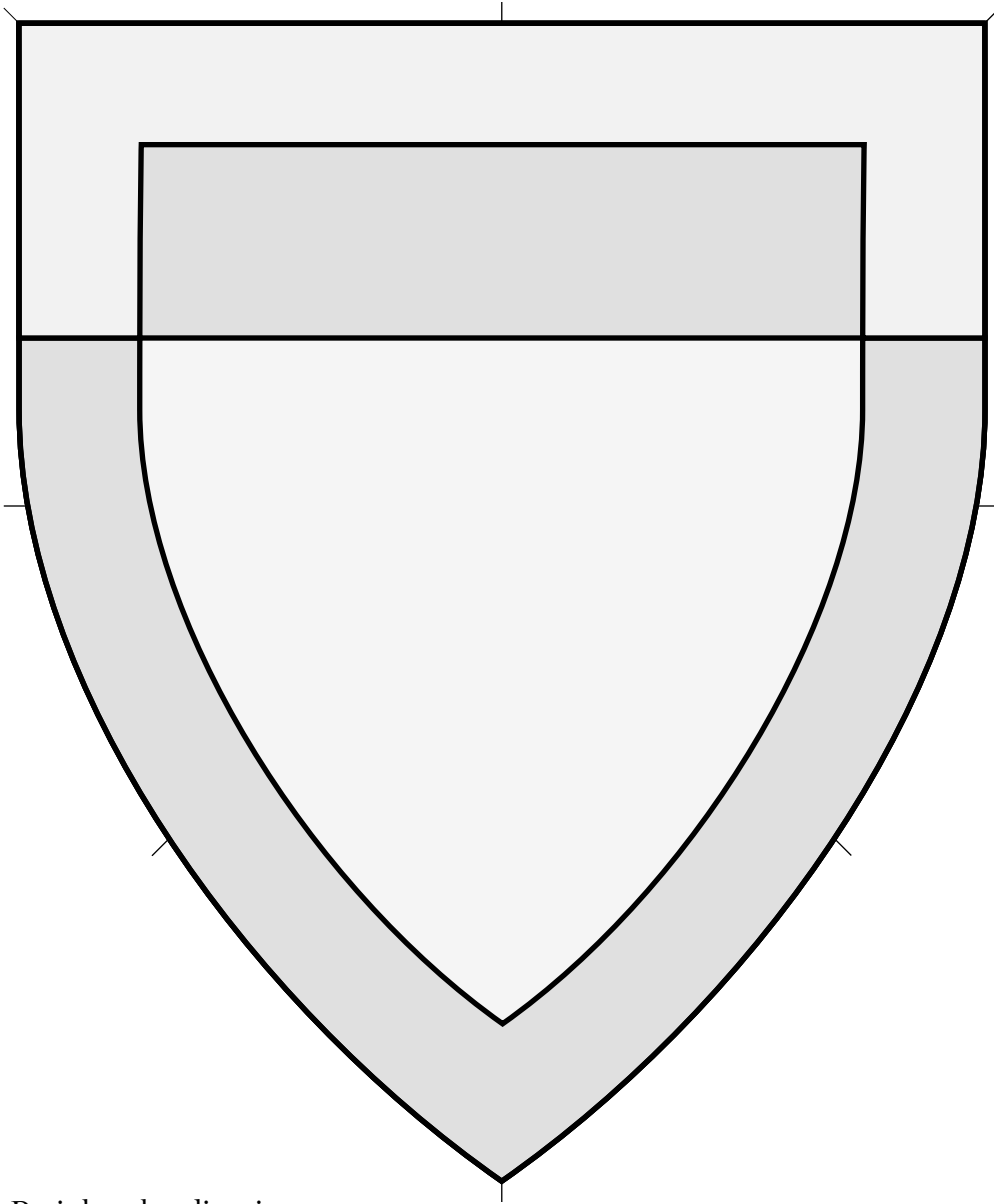

Peripheral ordinaries.

Counterchanging a bordure over a chief is considered a Step From Core Practice (SFCP).

Chief And A Bordure Counterchanged 4.328

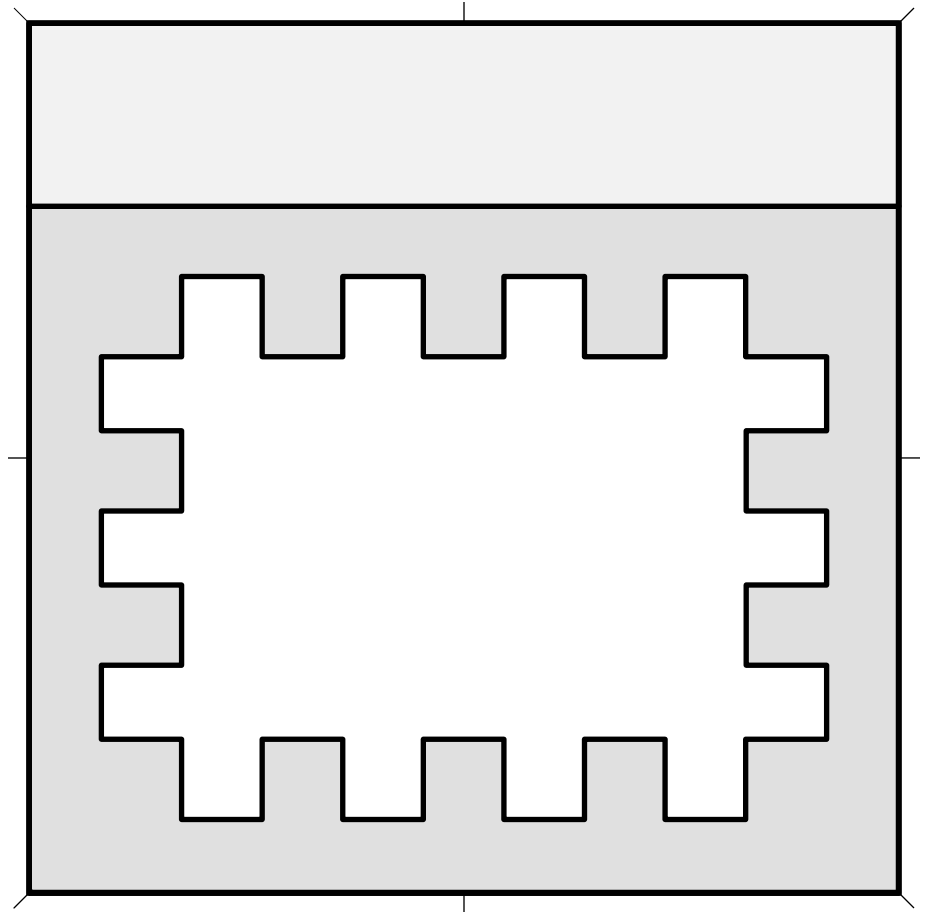
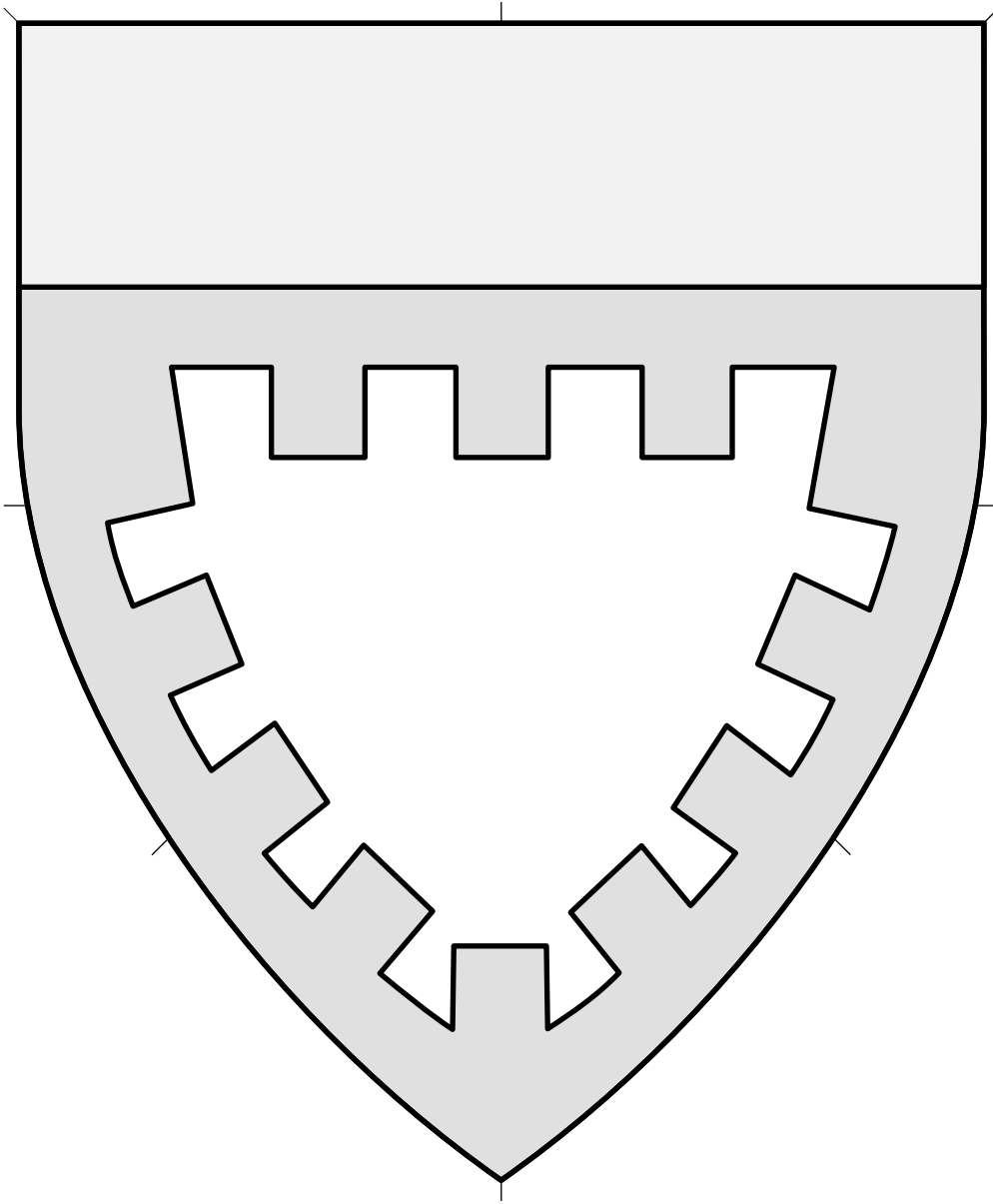

Peripheral ordinaries.

Artist: Vémundr Syvursson.

Adapted by Mathghamhain Ua Ruadháin.

Chief And A Bordure Embattled 4.329

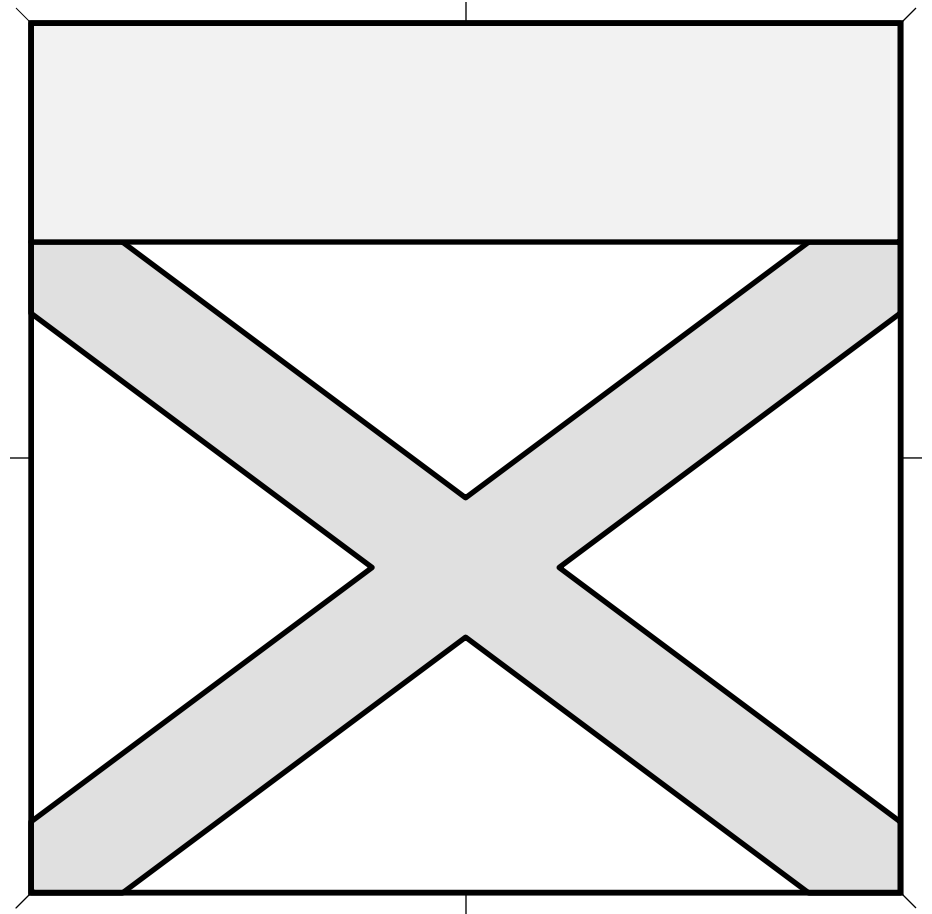
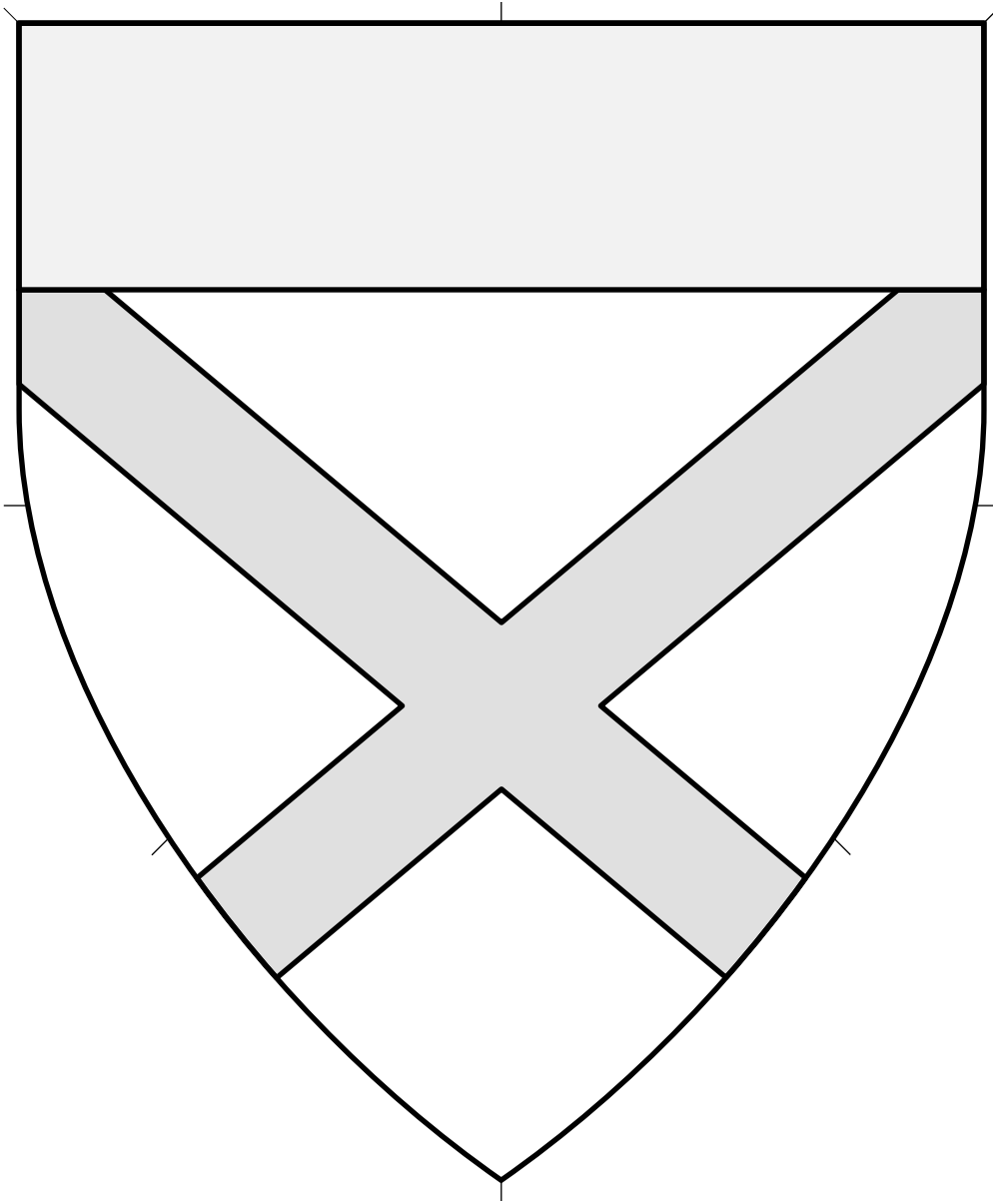

When a chief is combined with a charge throughout, the other charge shifts downwards.

Source: Fenwick Roll. Artist unknown.
Adapted by Mathghamhain Ua Ruadháin.

Chief and a Saltire 4.330

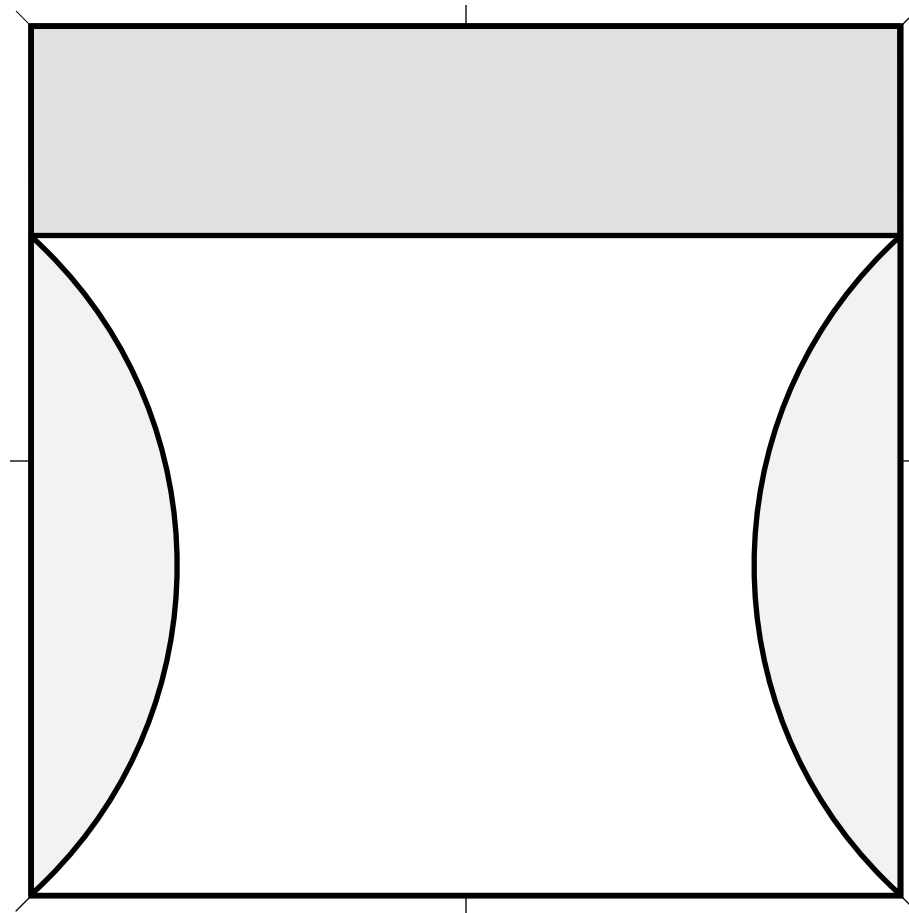
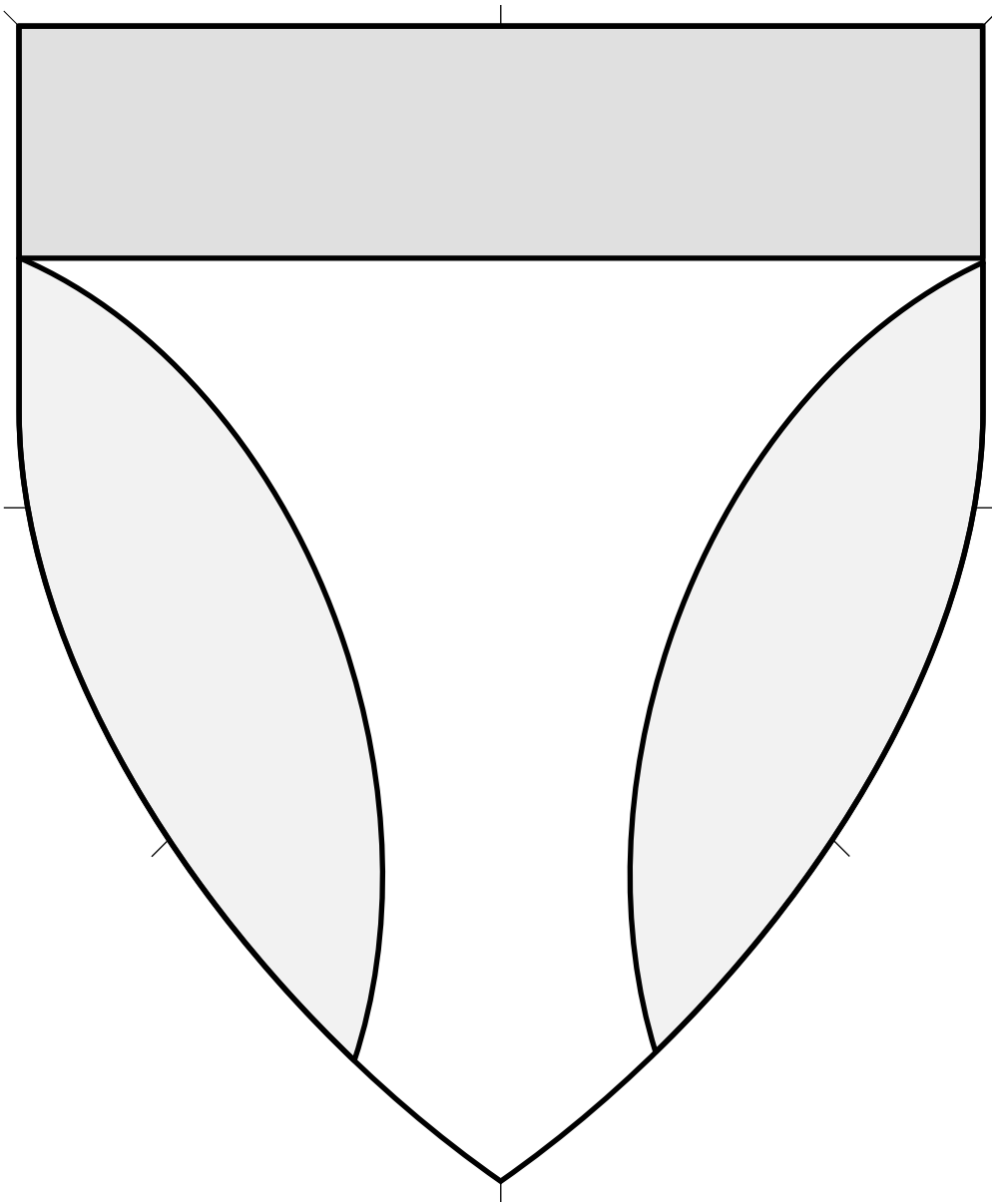

Peripheral ordinaries.
Artist: Vémundr Syvursson.

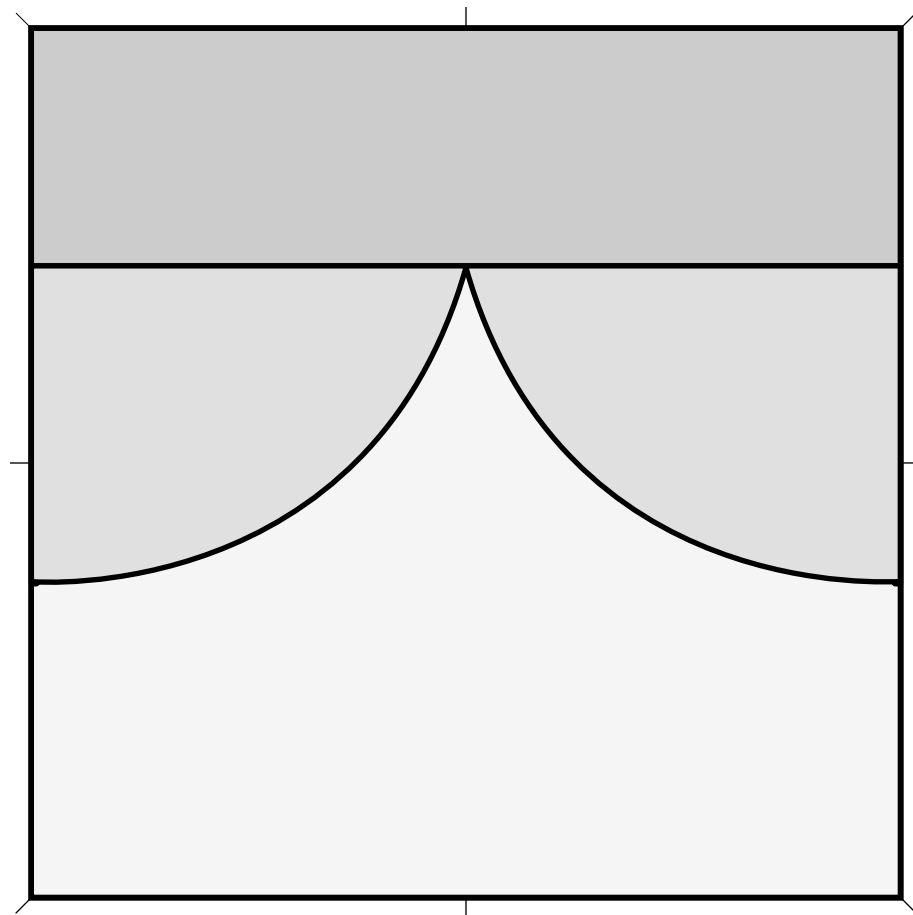
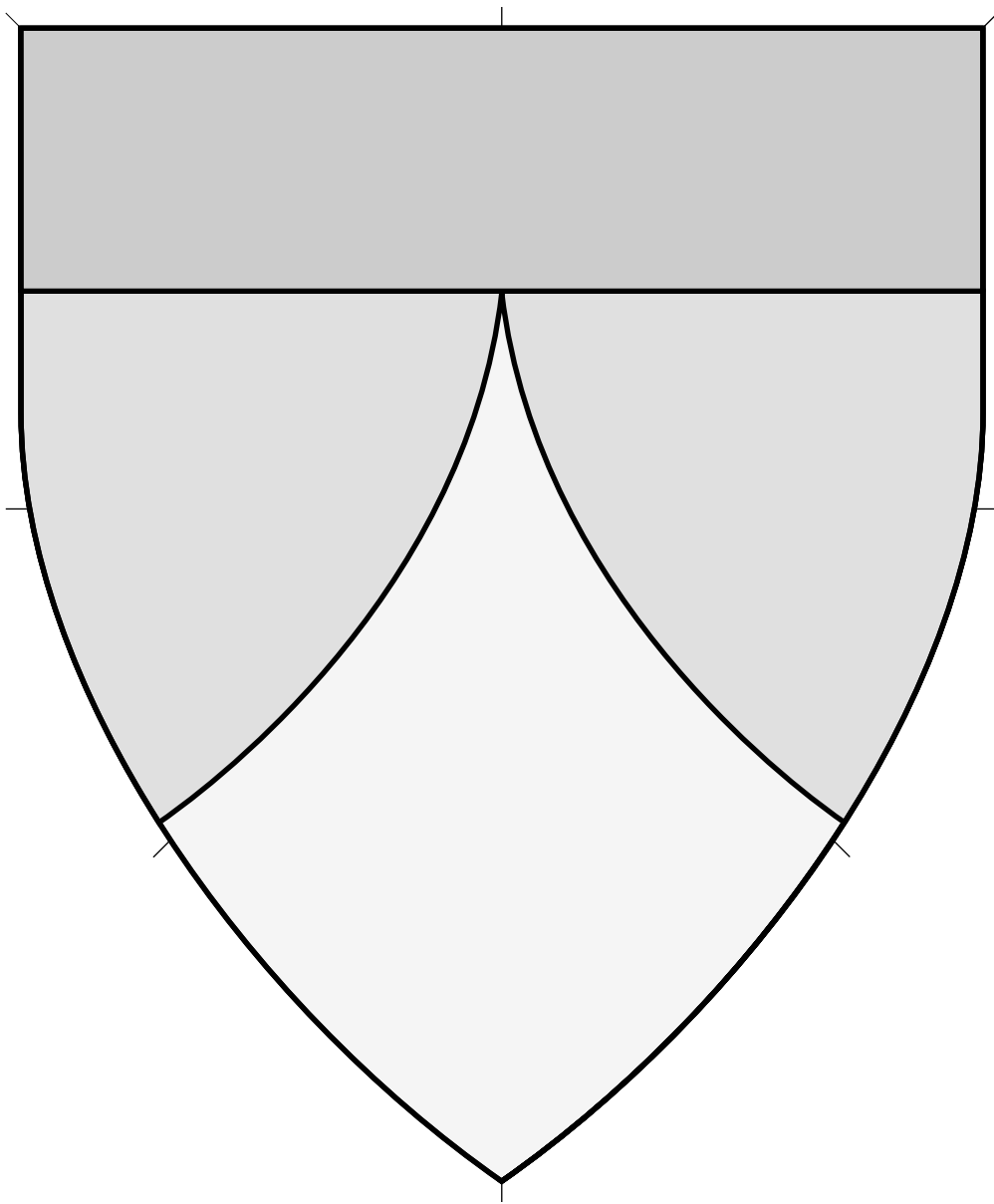

Peripheral ordinary and field division.
Artist: Lily Morgaine.

Chief, Chapé Ployé And A 4.332

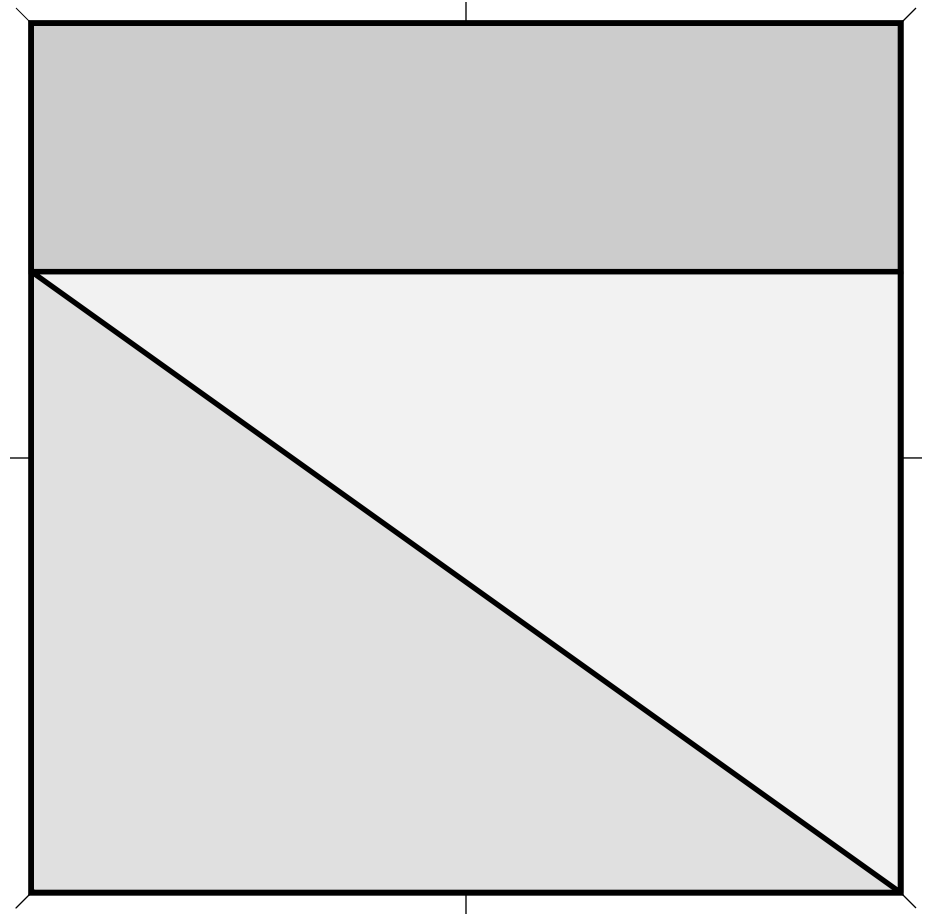
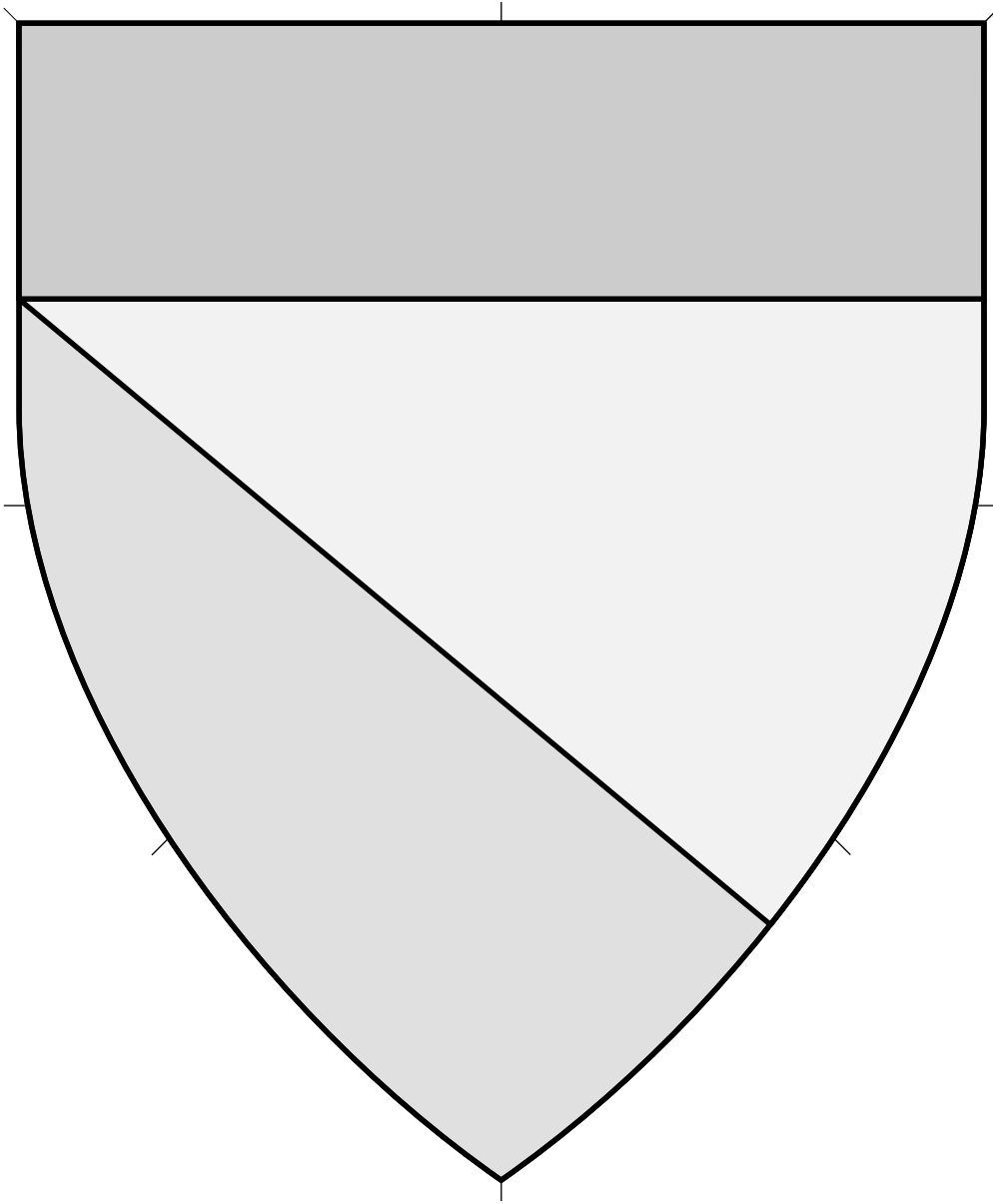

Peripheral ordinary and field division.

When a chief is combined with a field division, the field is divided as if the chief removed space from the field.

Chief, Per Bend And A 4.333

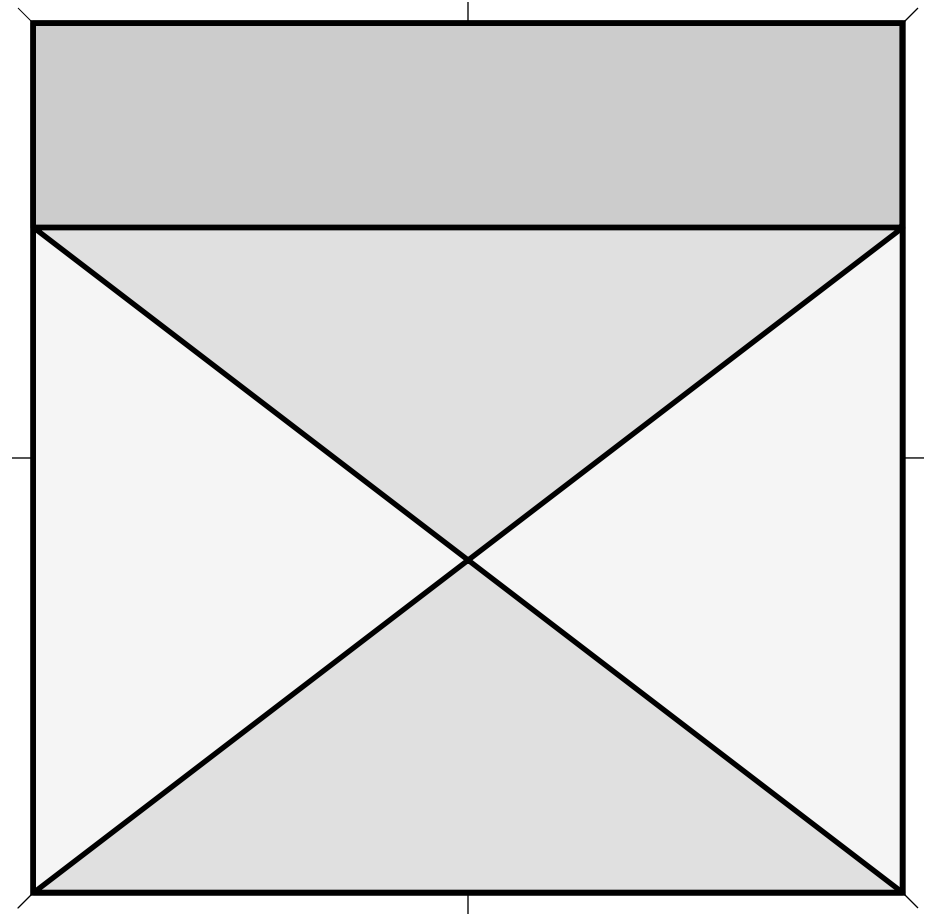
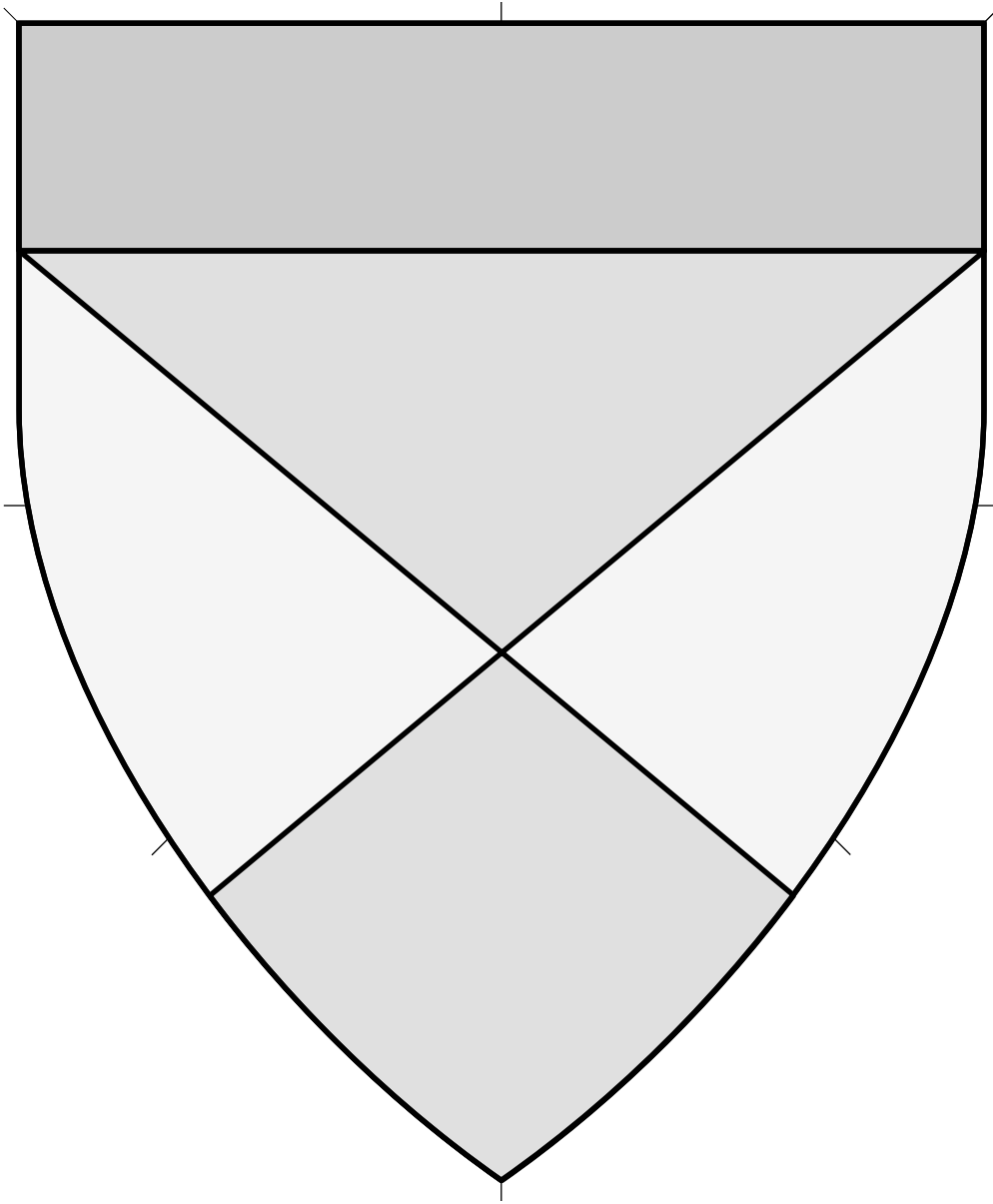

Peripheral ordinary and field division.

When a chief is combined with a field division, the field is divided as if the chief removed space from the field.

Chief, Per Saltire And A 4.334

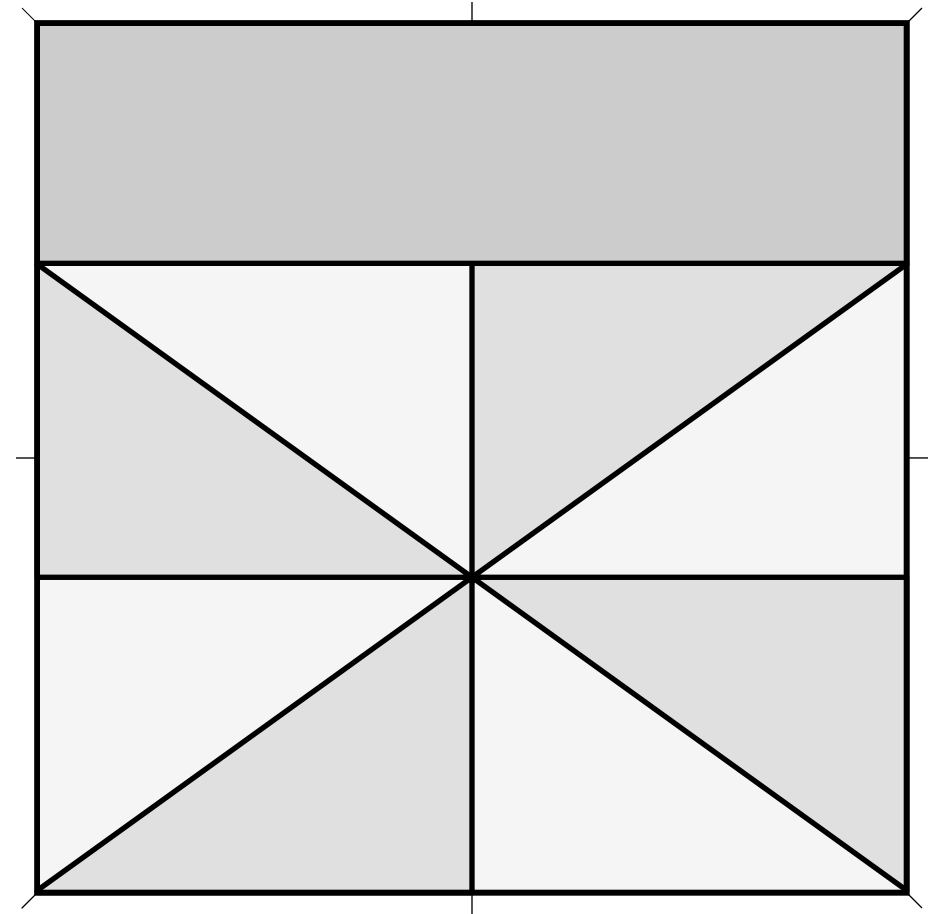
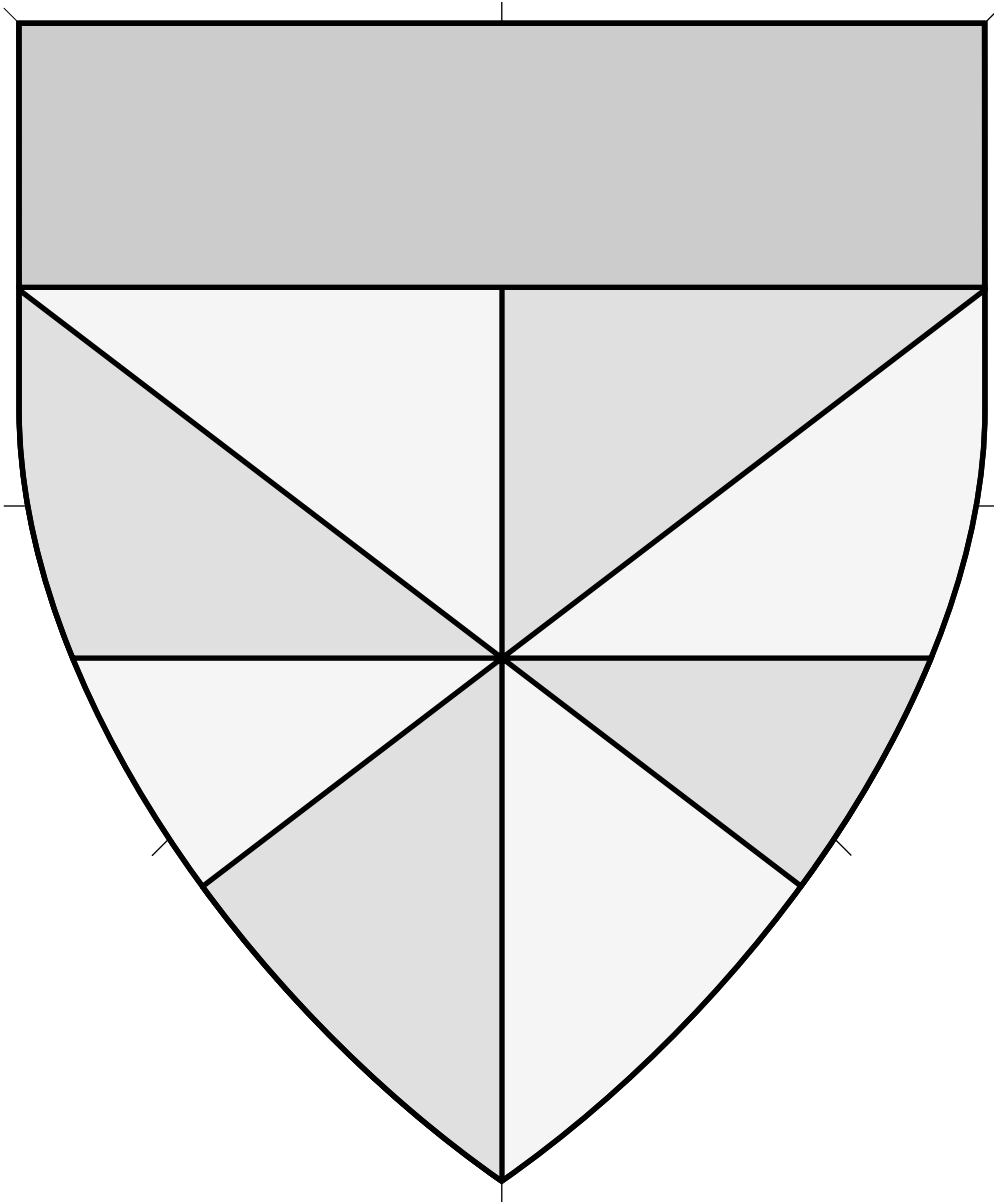

Peripheral ordinary and field division.

When a gyronny field is combined with a chief, the gyronny's center shifts downwards.

Chief, Gyronny And A 4.335

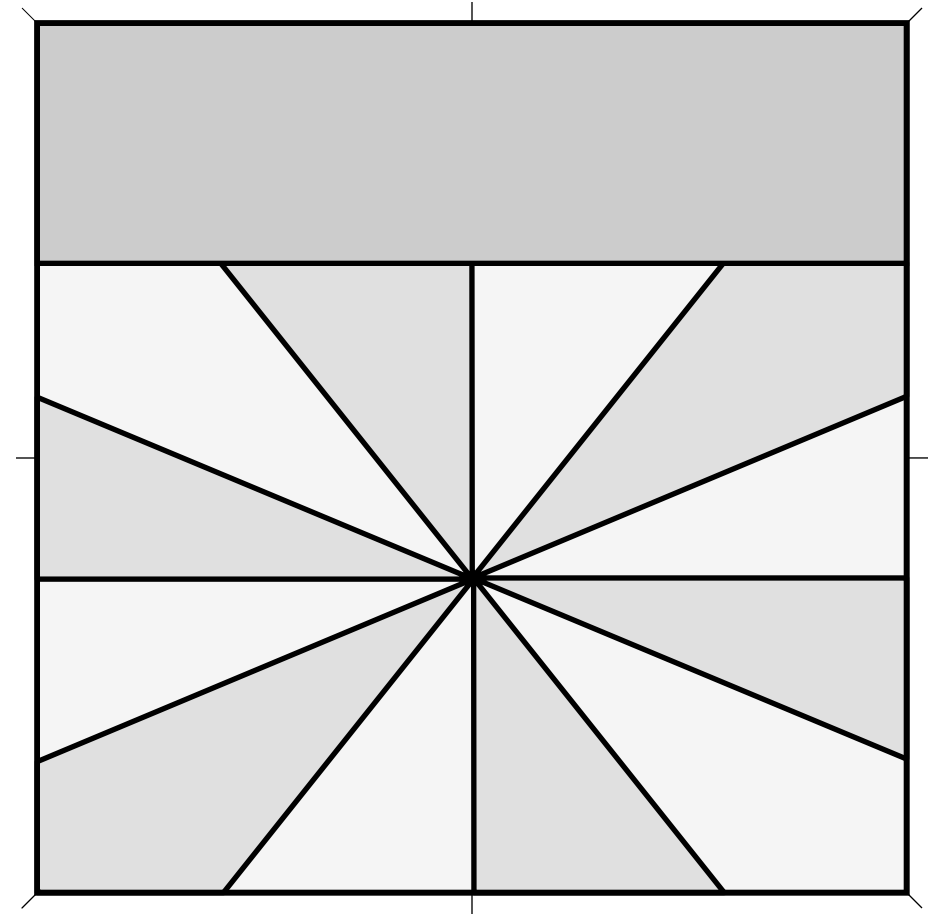
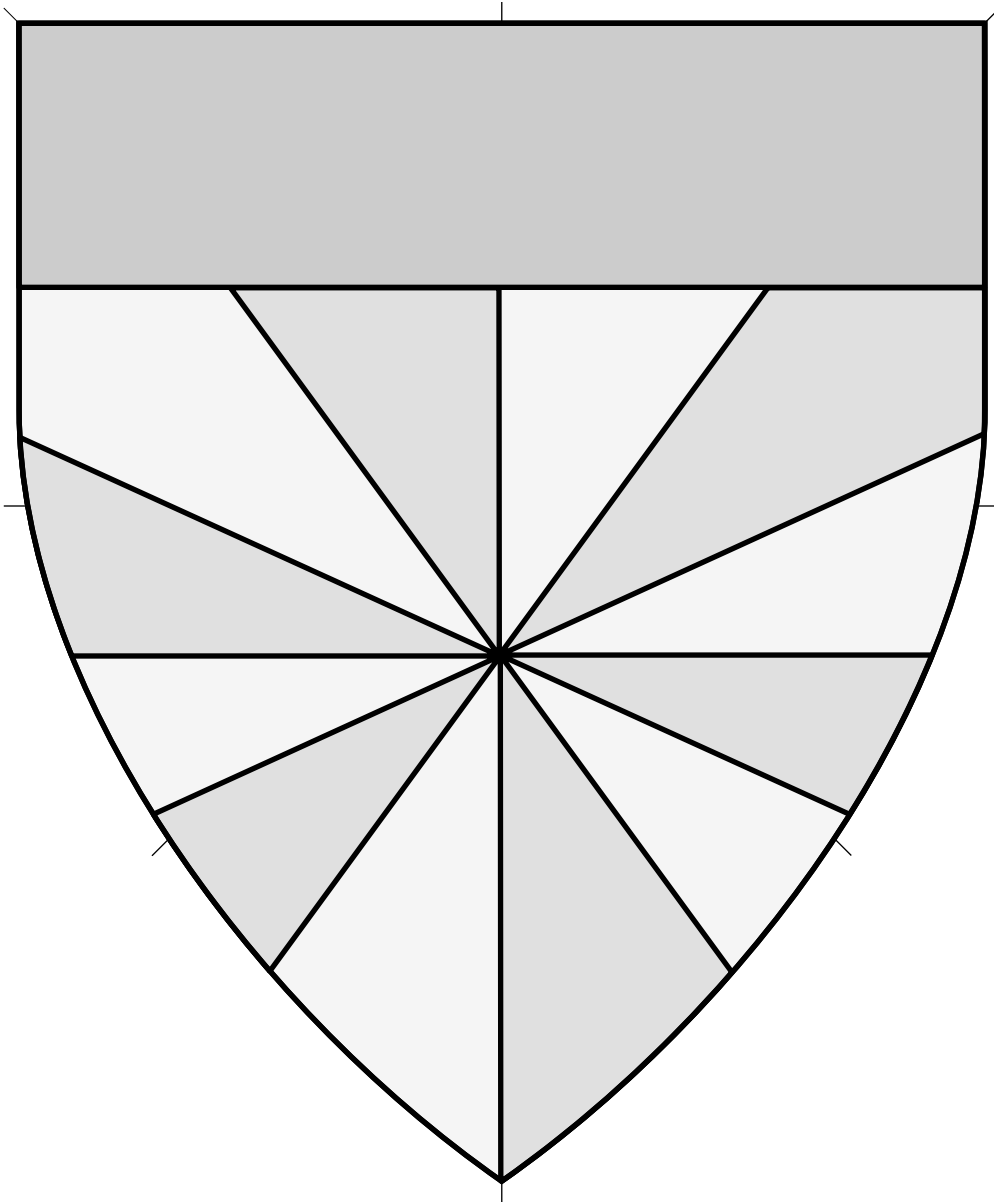

Peripheral ordinary and field division.

When a gyronny field is combined with a chief, the gyronny's center shifts downwards.

Chief, Gyronny of 12 And A 4.336

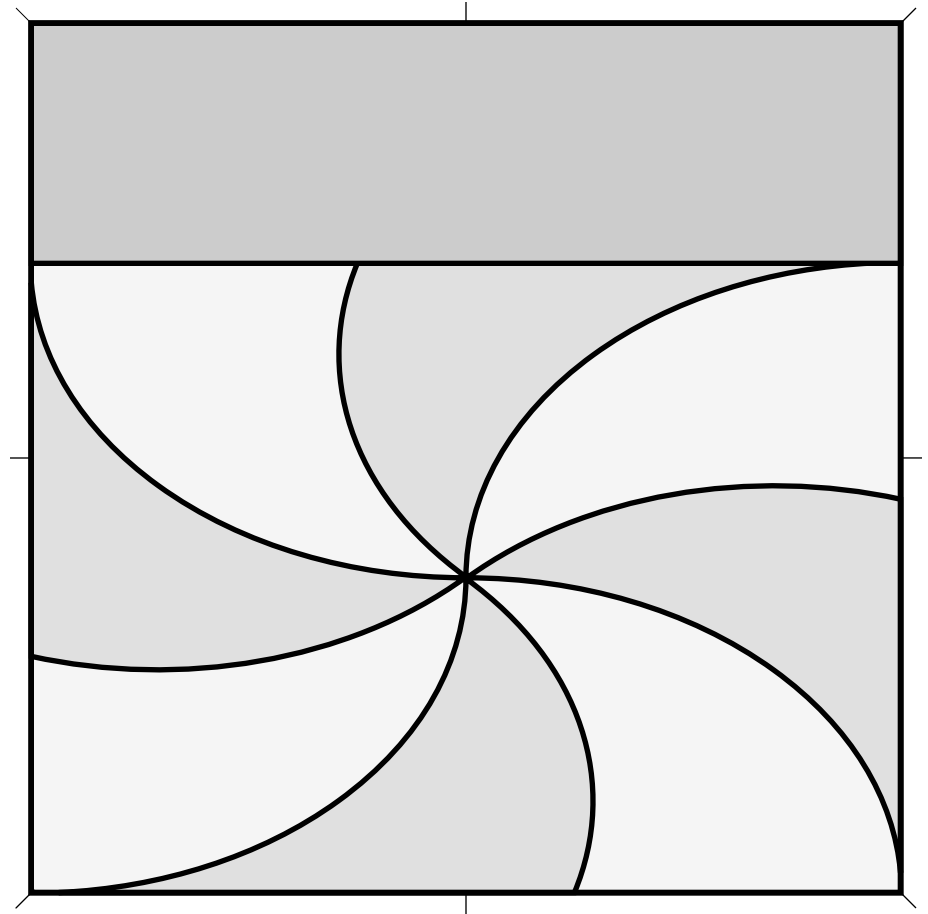
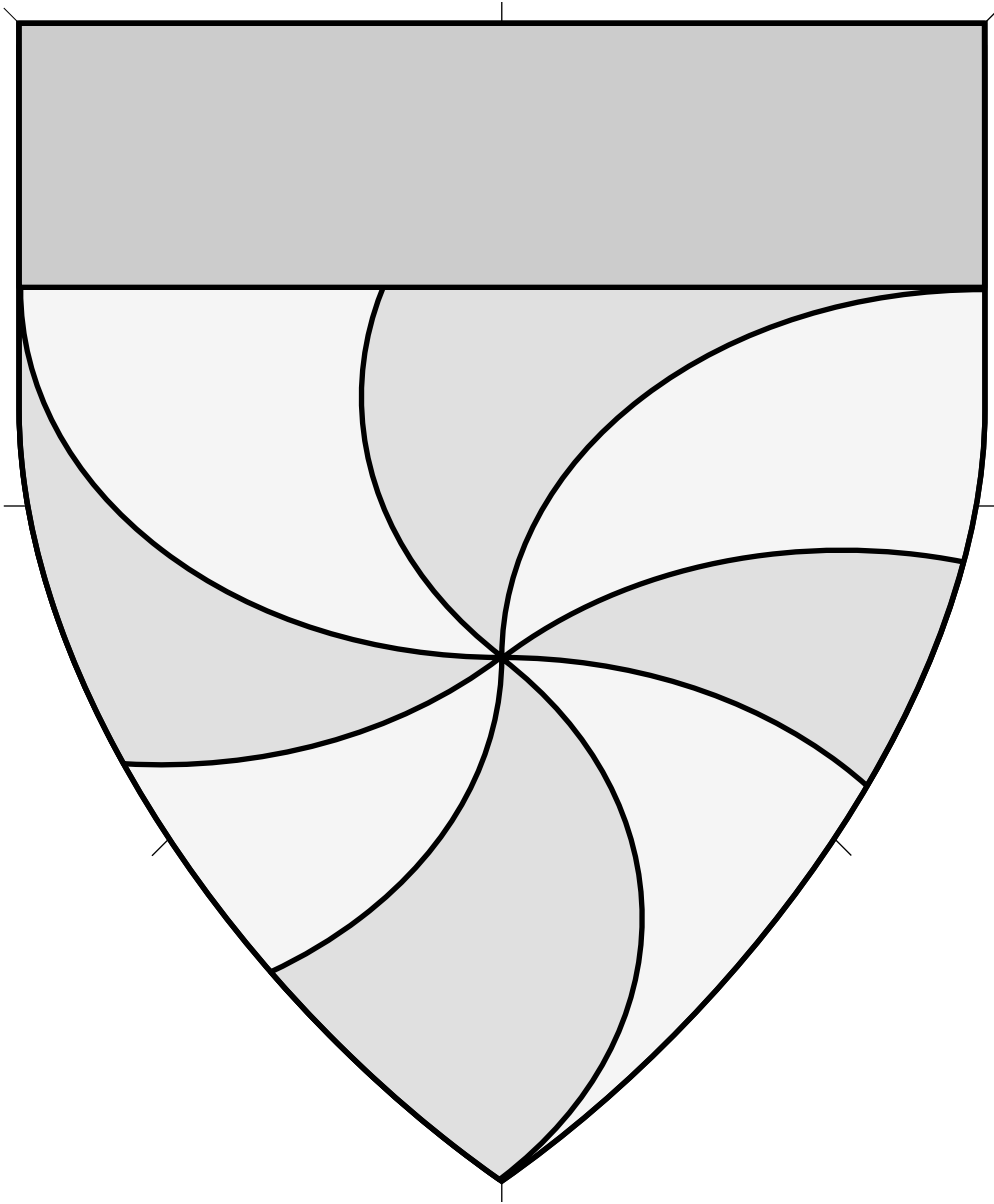

Peripheral ordinary and field division.

When a gyronny field is combined with a chief, the gyronny's center shifts downwards.

Chief, Gyronny Arrondi And A 4.337

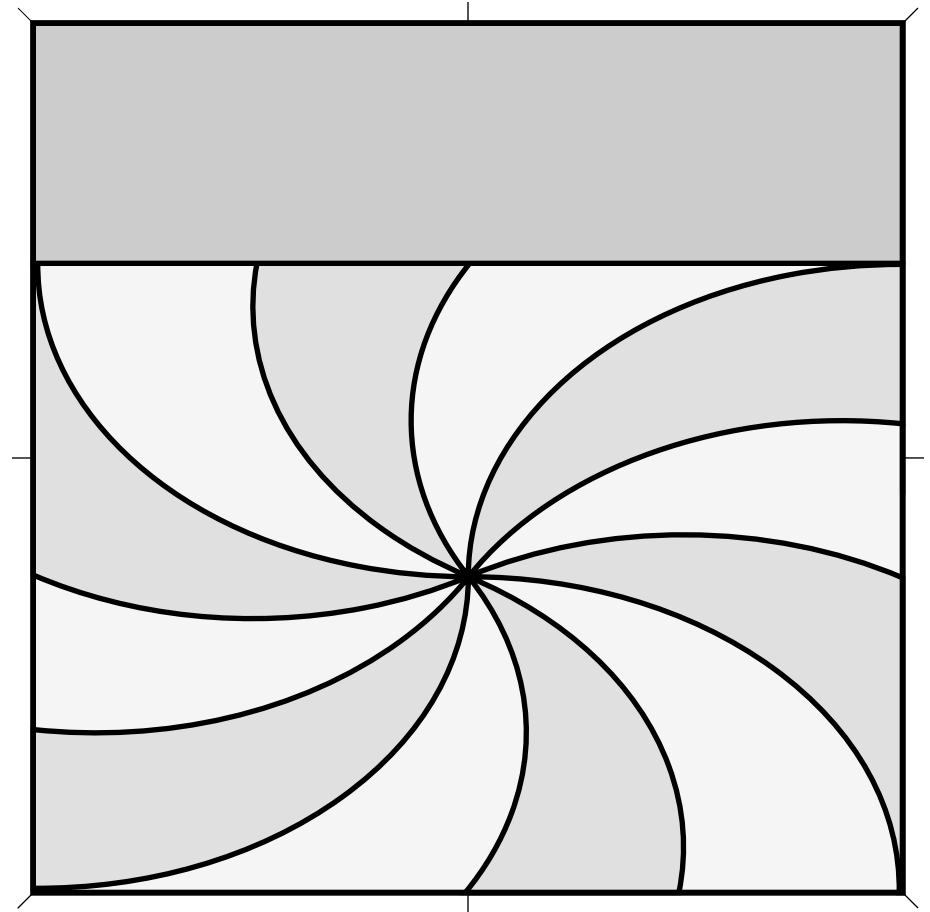
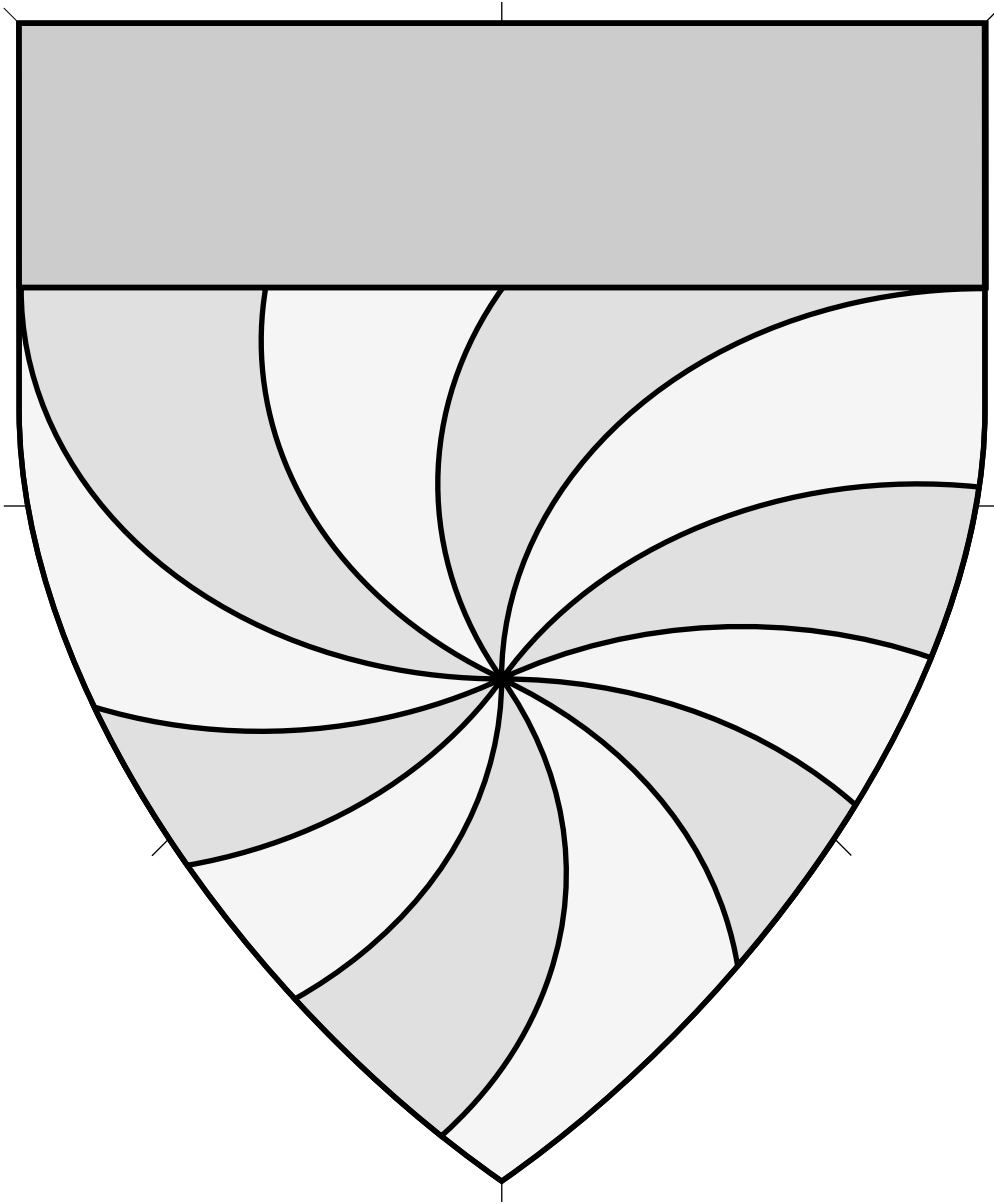

Peripheral ordinary and field division.

When a gyronny field is combined with a chief, the gyronny's center shifts downwards.

Chief, Gyronny Arrondi of 12 And A 4.338

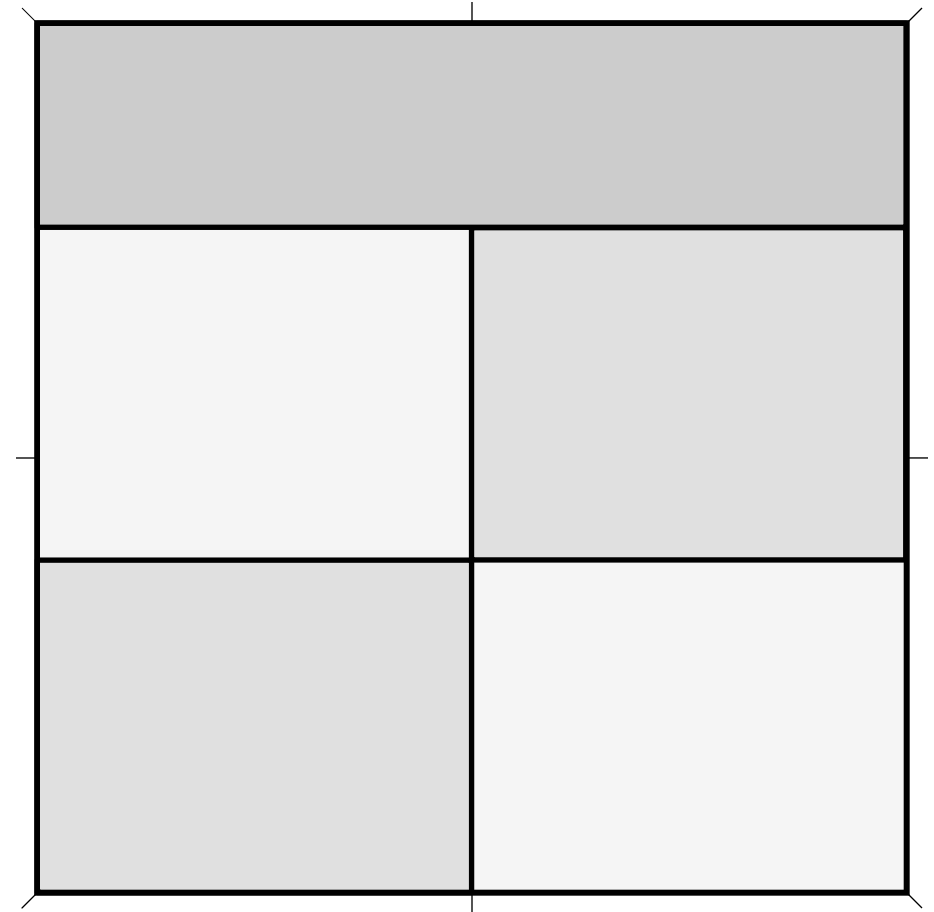
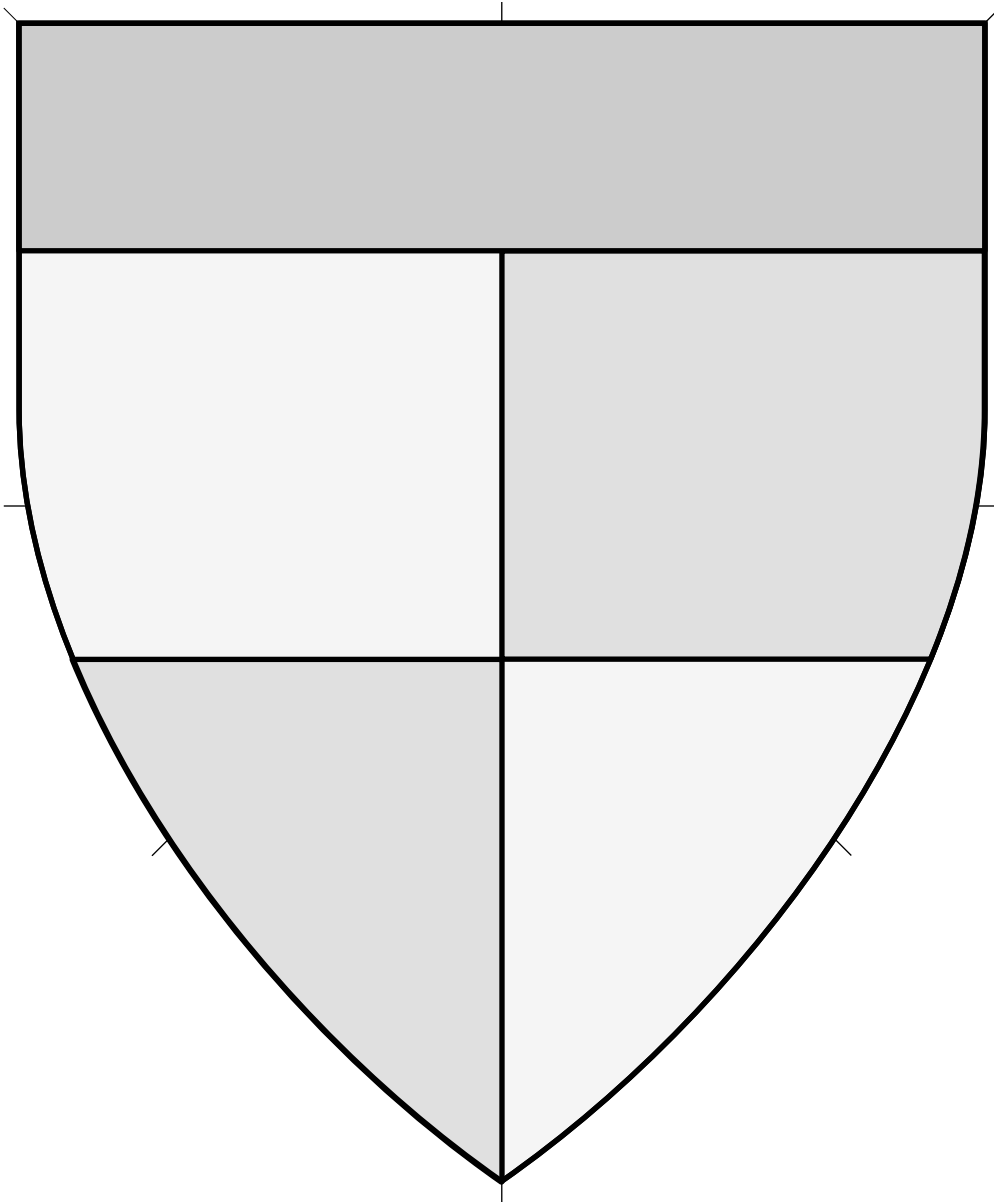

Peripheral ordinary and field division.

When a chief is combined with a field division, the field is divided as if the chief removed space from the field.

Chief, Quarterly And A 4.339

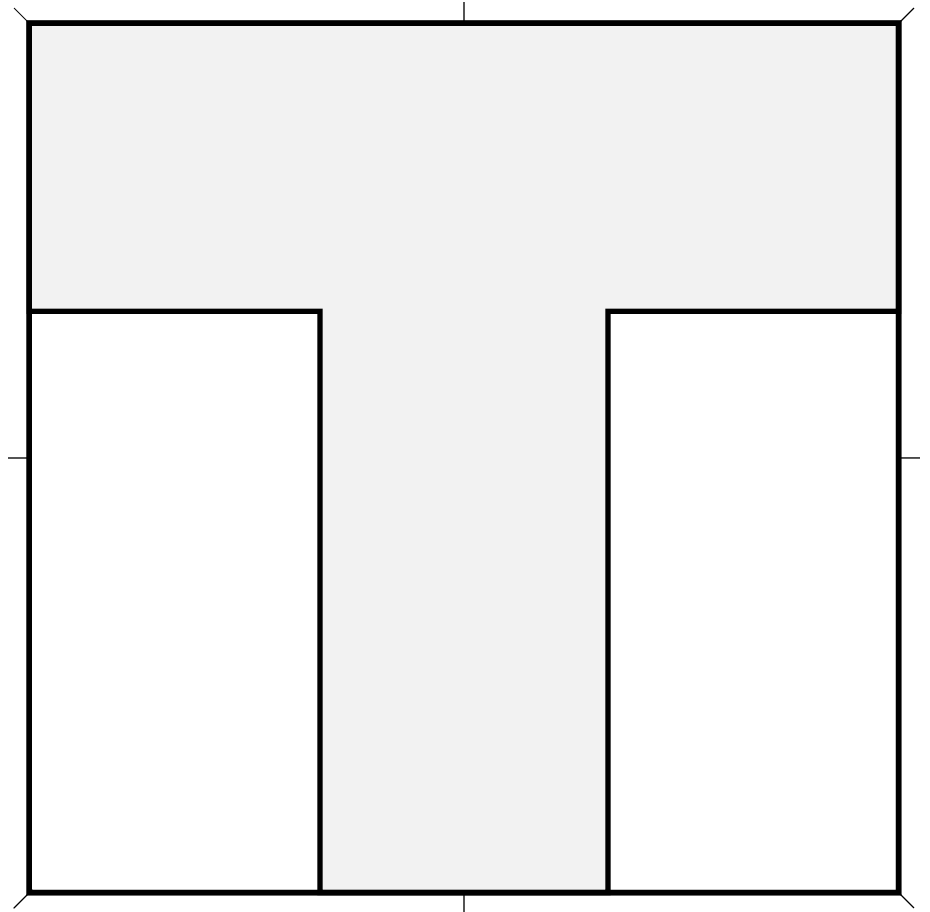
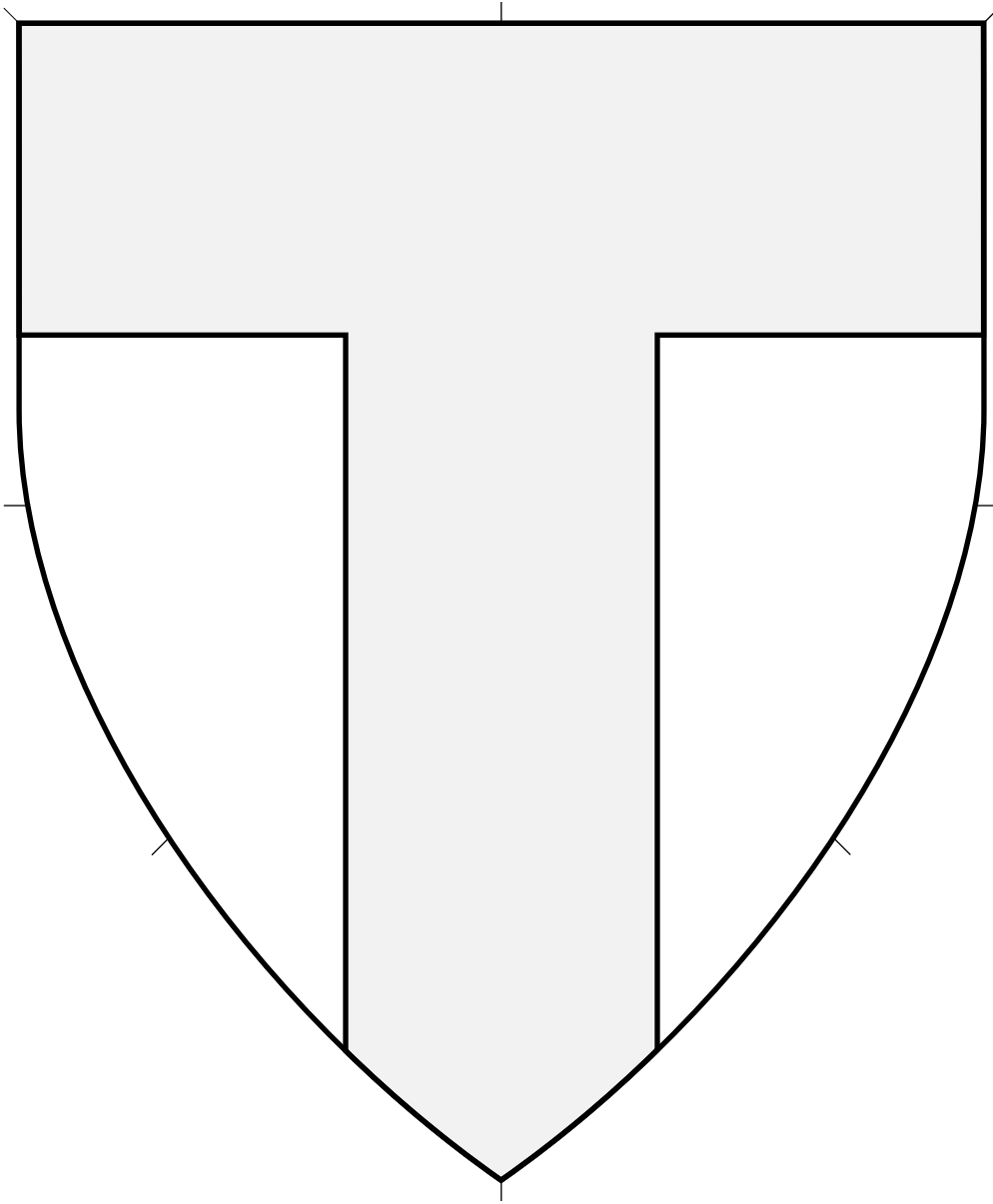

Central ordinary. Combines a chief and a pale as a single charge.

Chief-Pale 4.340

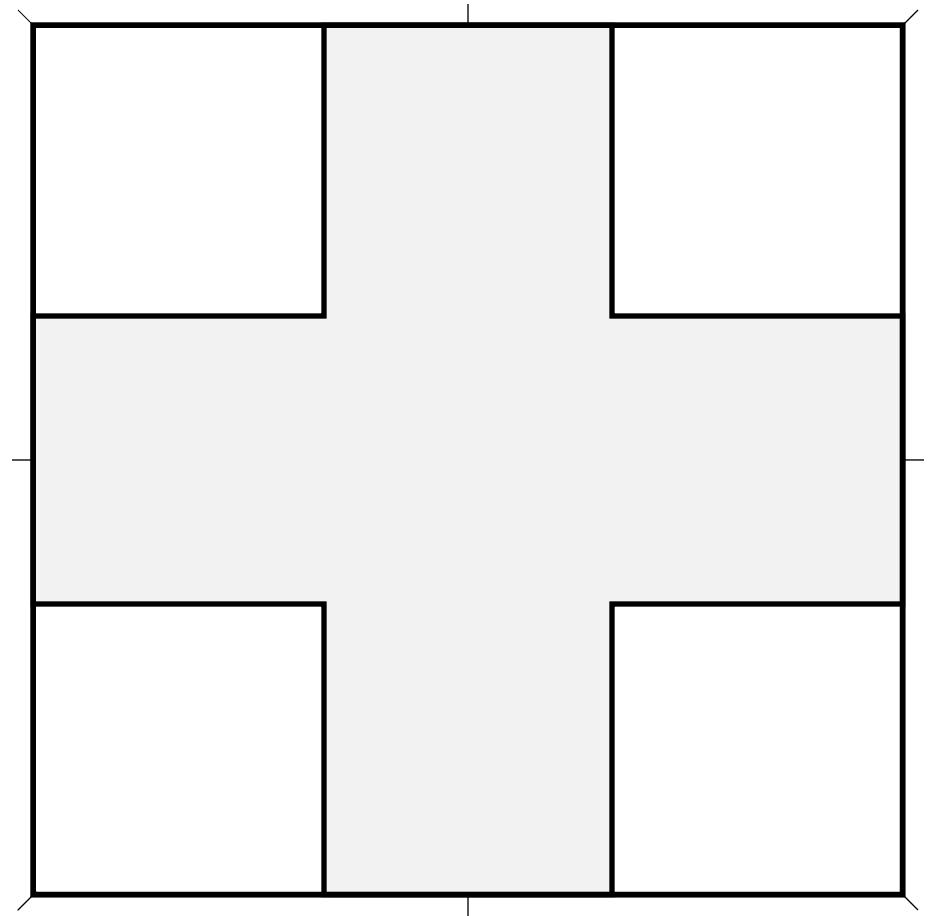
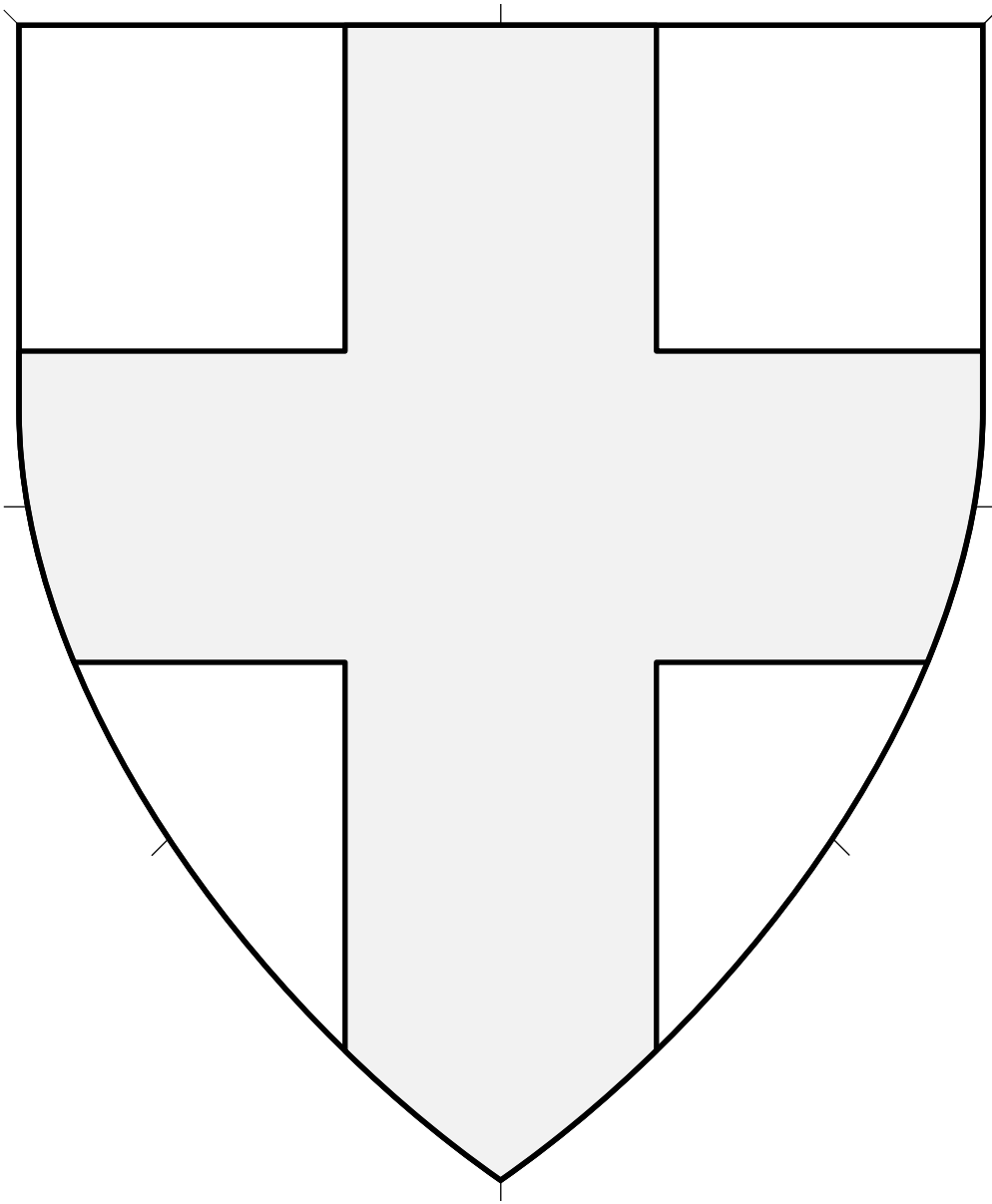

Central ordinary. The width of each arm is typically a third of the width of the device or a bit narrower. This is a thick cross. Should be centered on the fess line.

Cross (1) 4.341

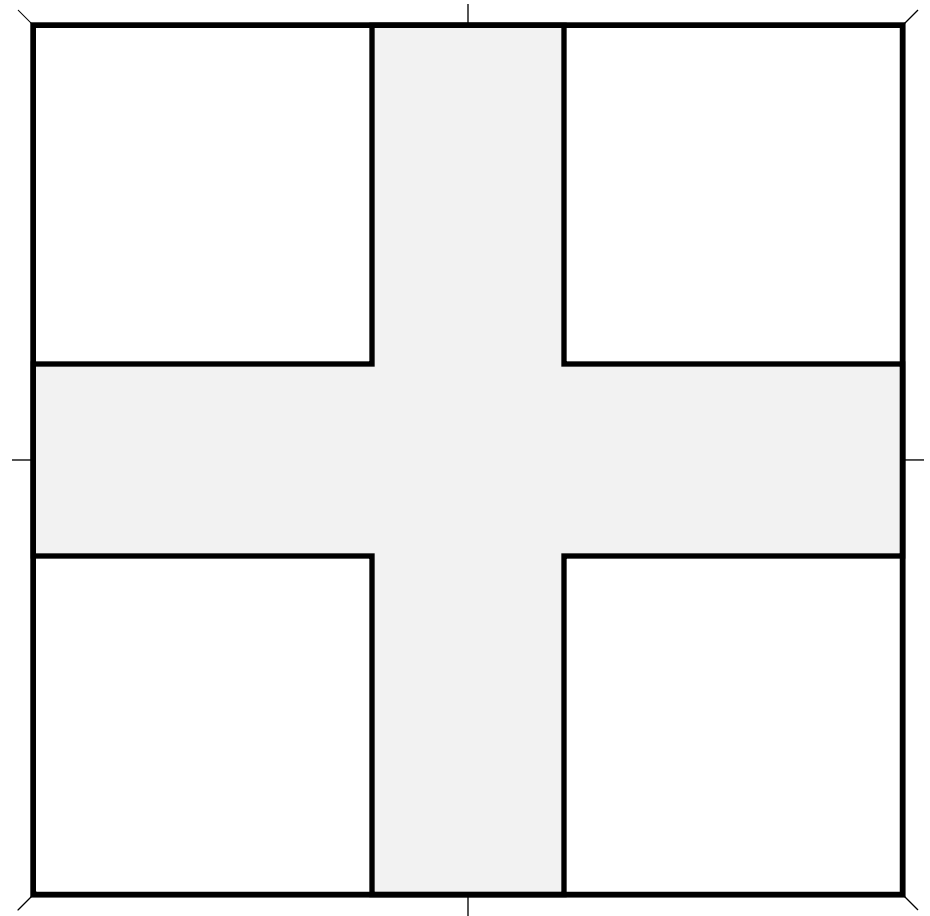
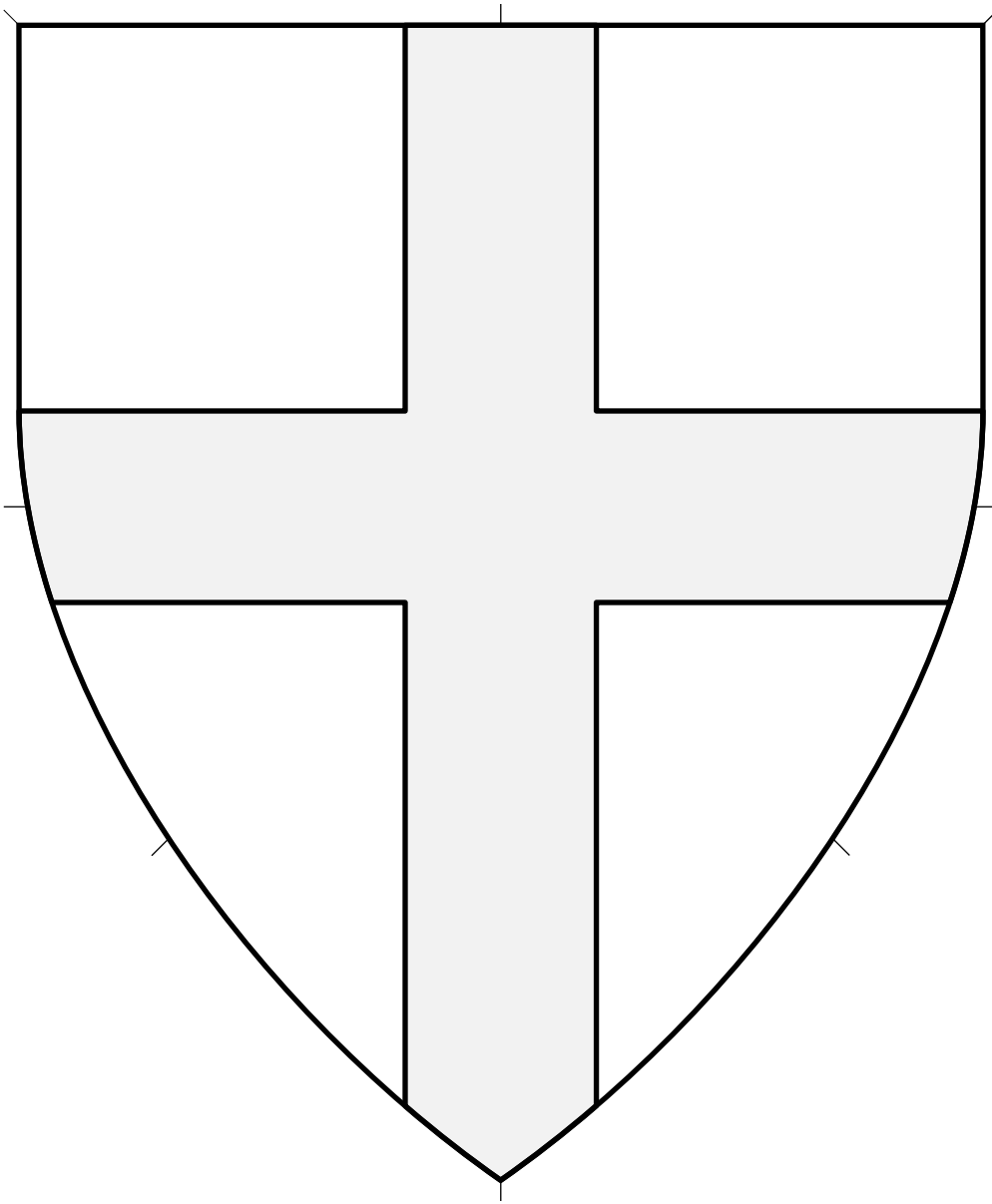

Central ordinary. The width of each arm is typically a third of the width of the device or a bit narrower. This is a medium cross. Should be centered on the fess line.

Cross (2) 4.342

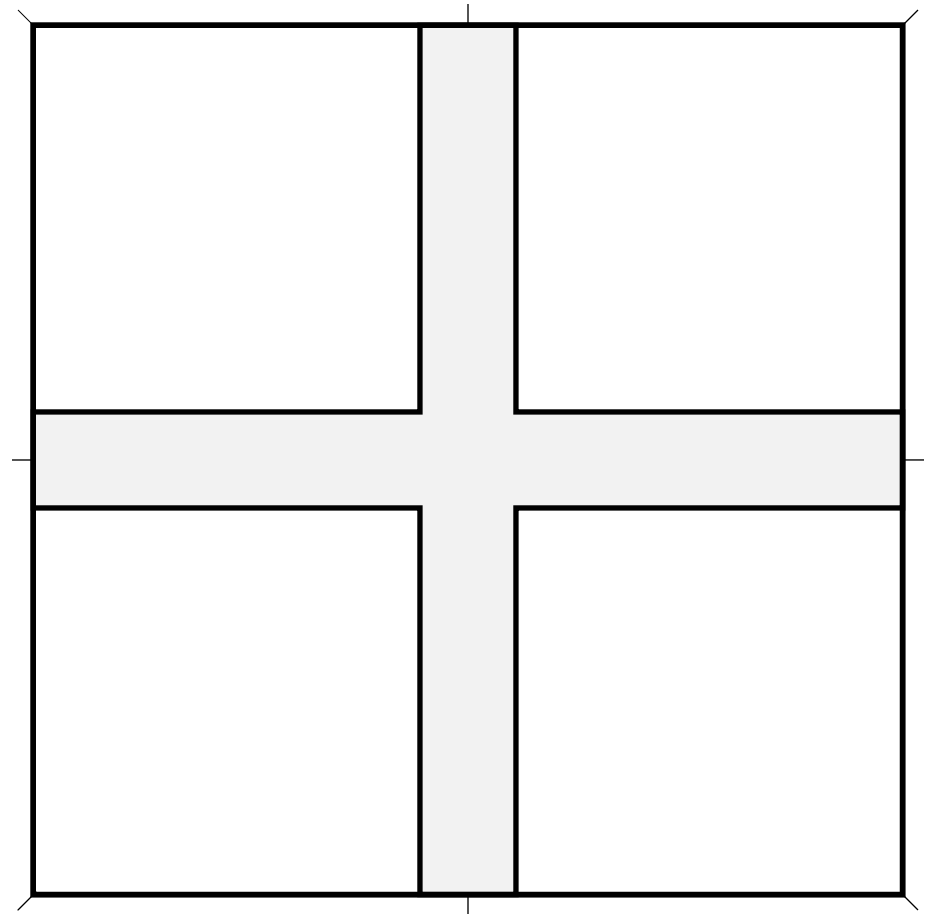
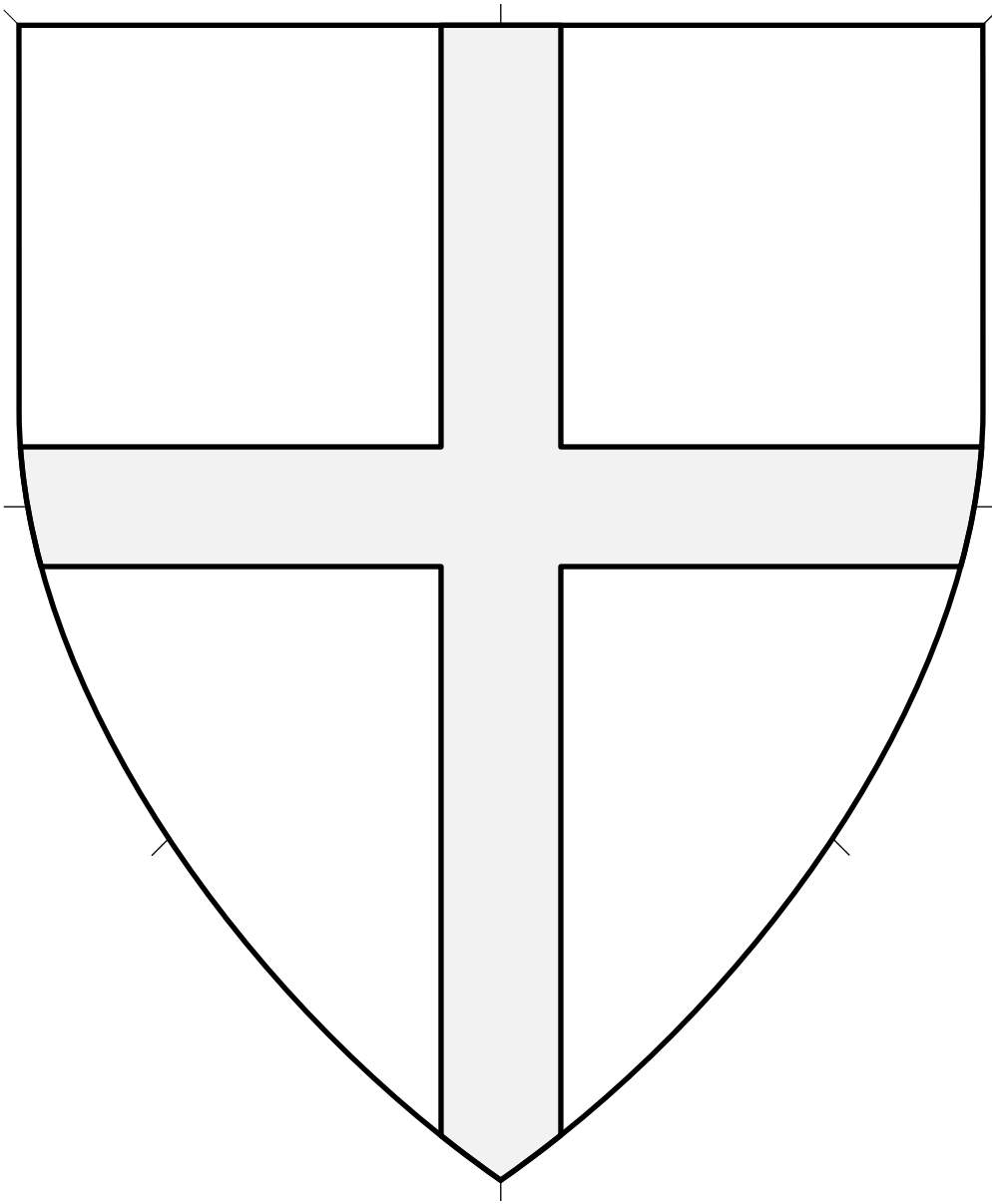

Central ordinary. The width of each arm is typically a third of the width of the device or a bit narrower. This is a very thin cross. Should be centered on the fess line.

Cross (3) 4.343

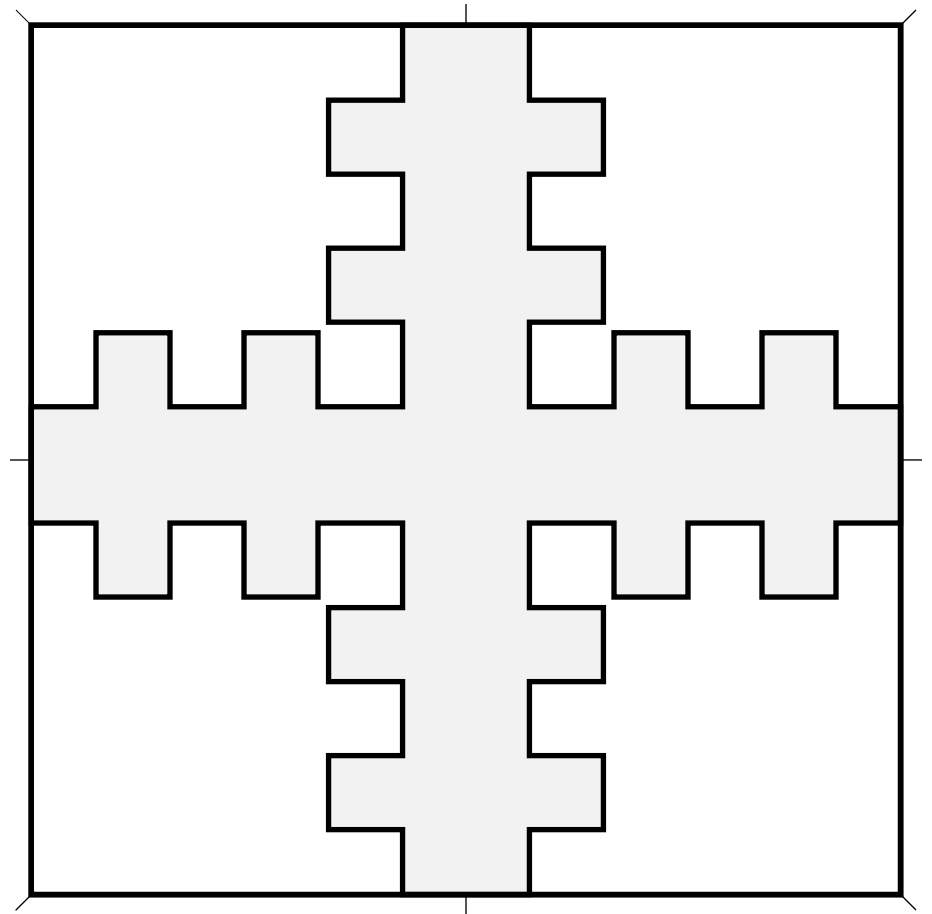
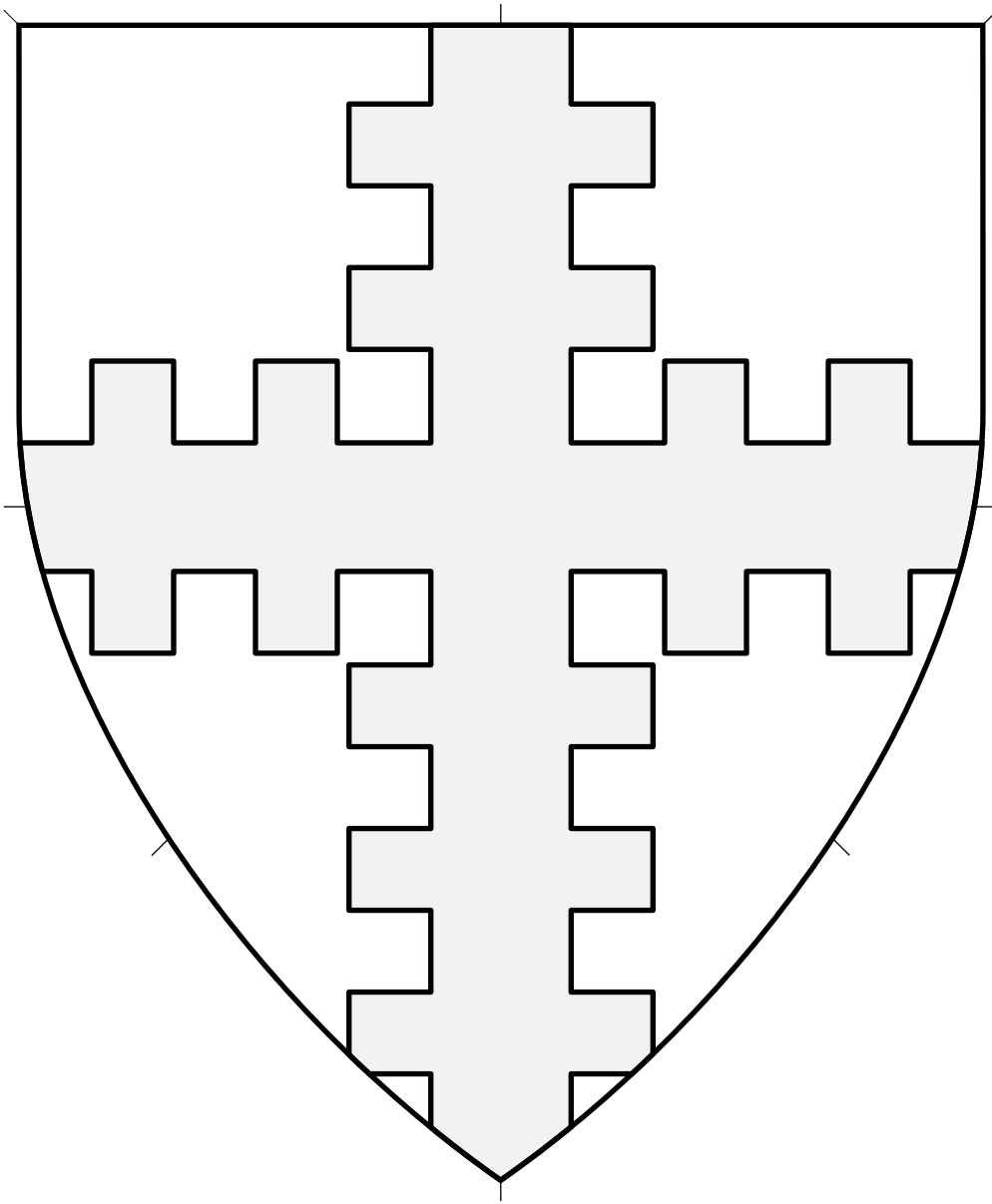

Central ordinary.

Cross Bretessed 4.344

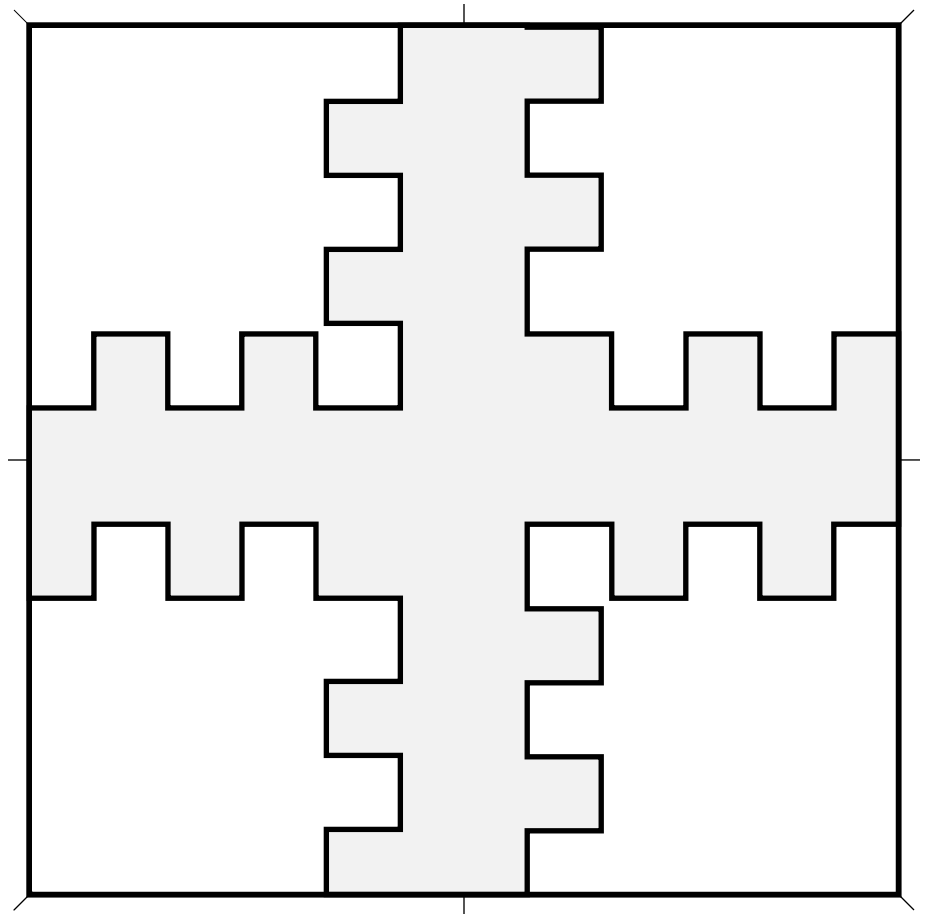
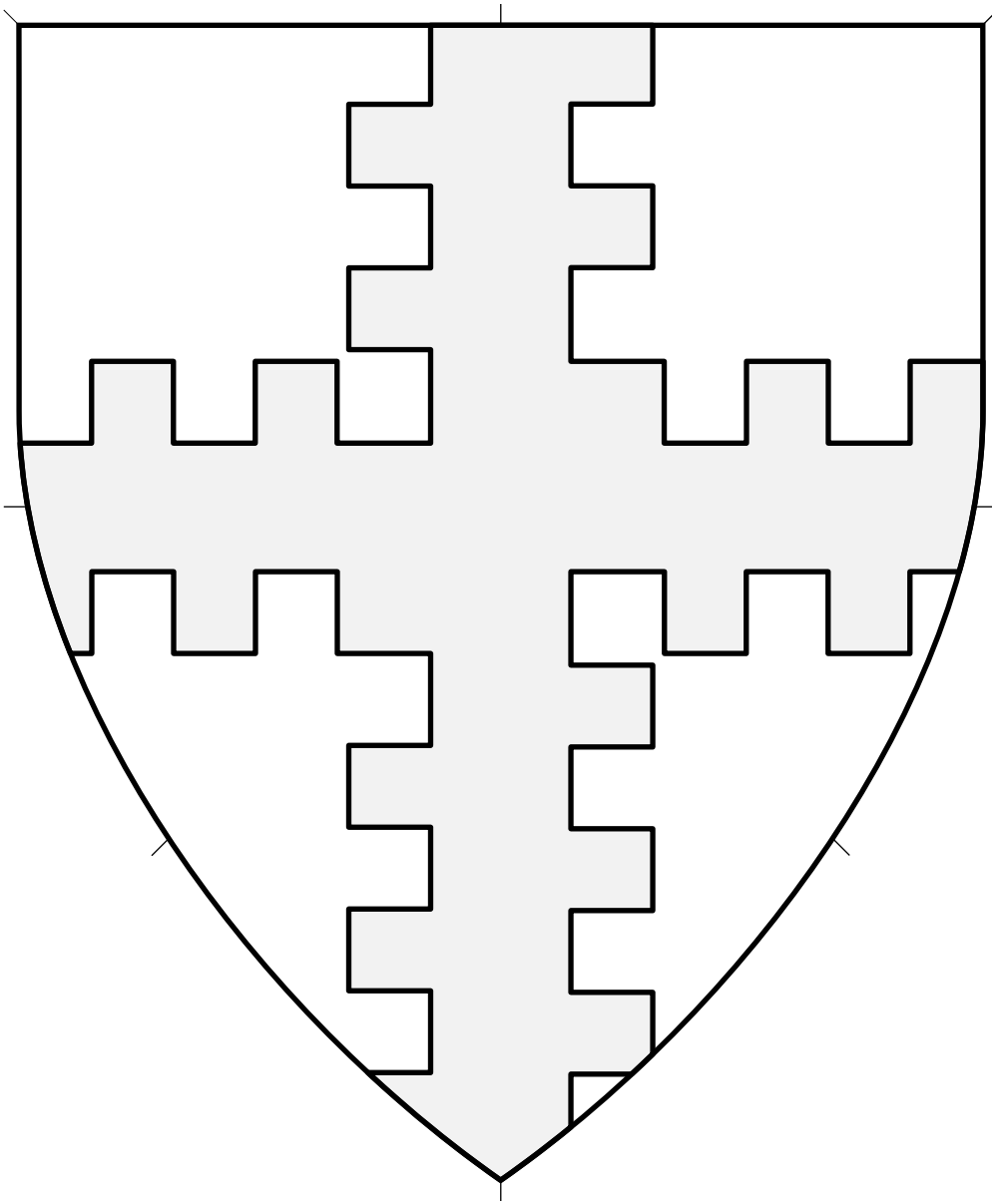

Central ordinary.

Cross Counter-Embattled 4.345

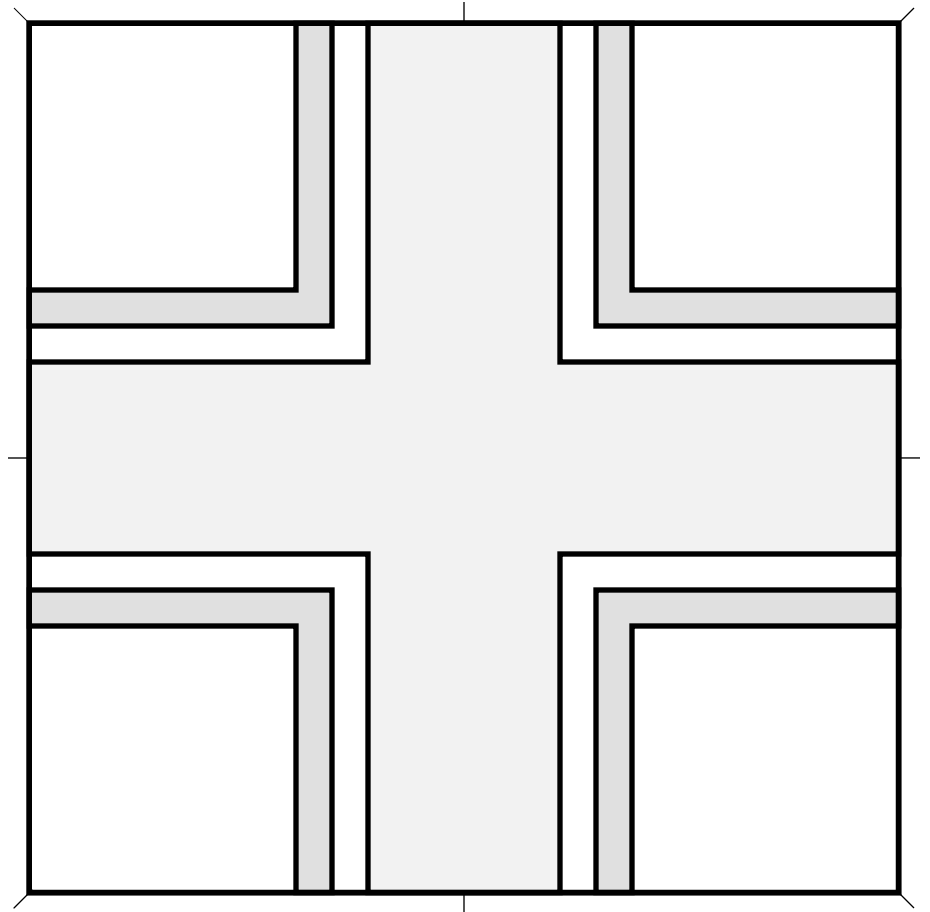
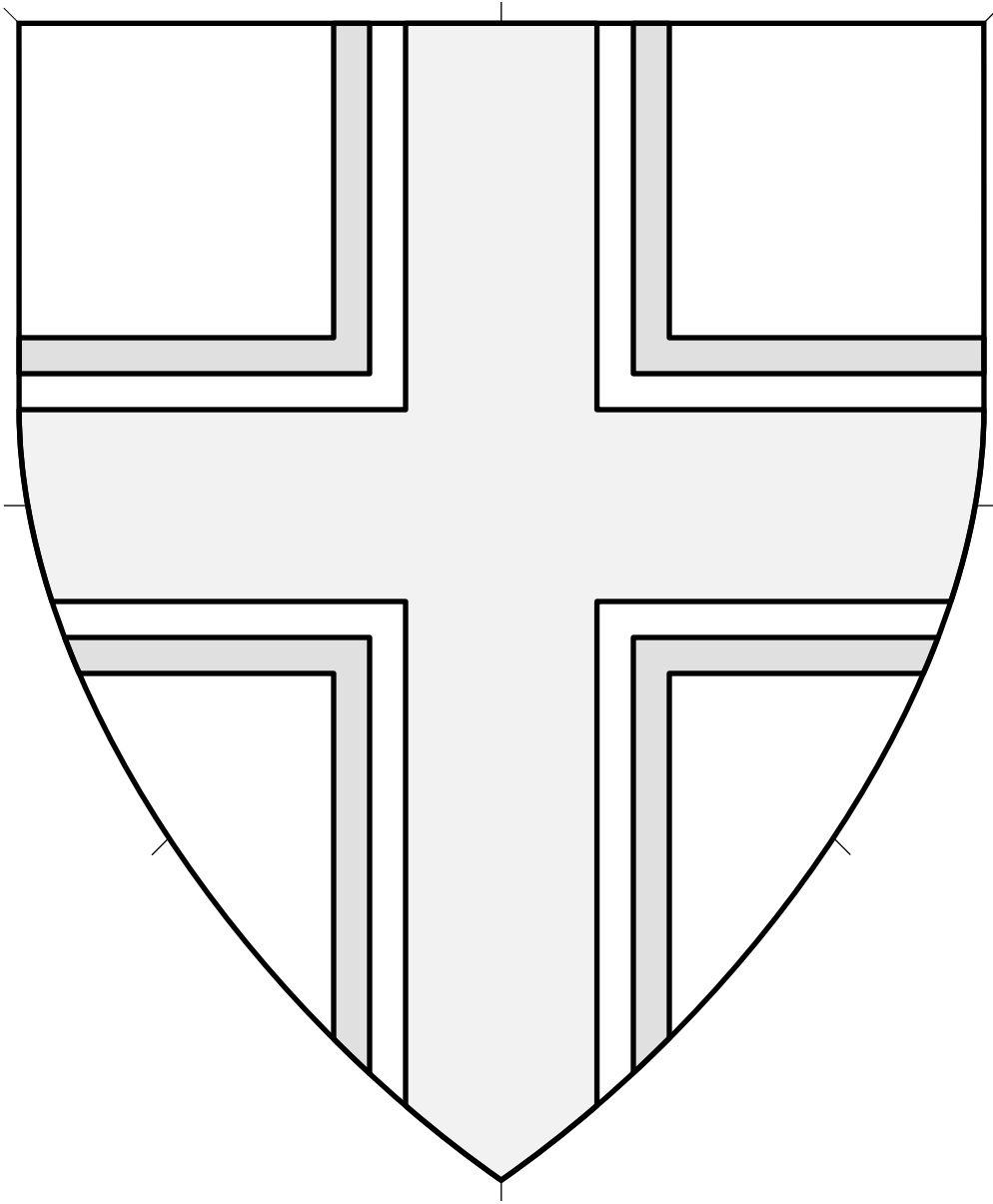

Central ordinary.

Cross Cotised • 4.346

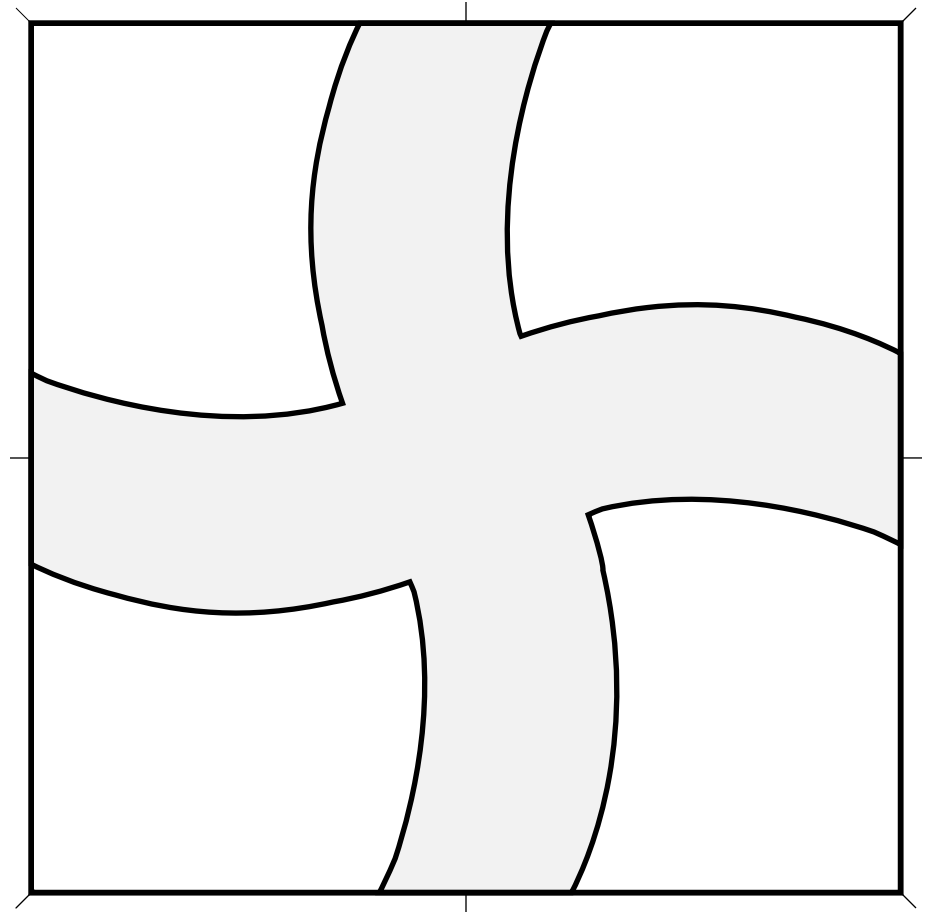
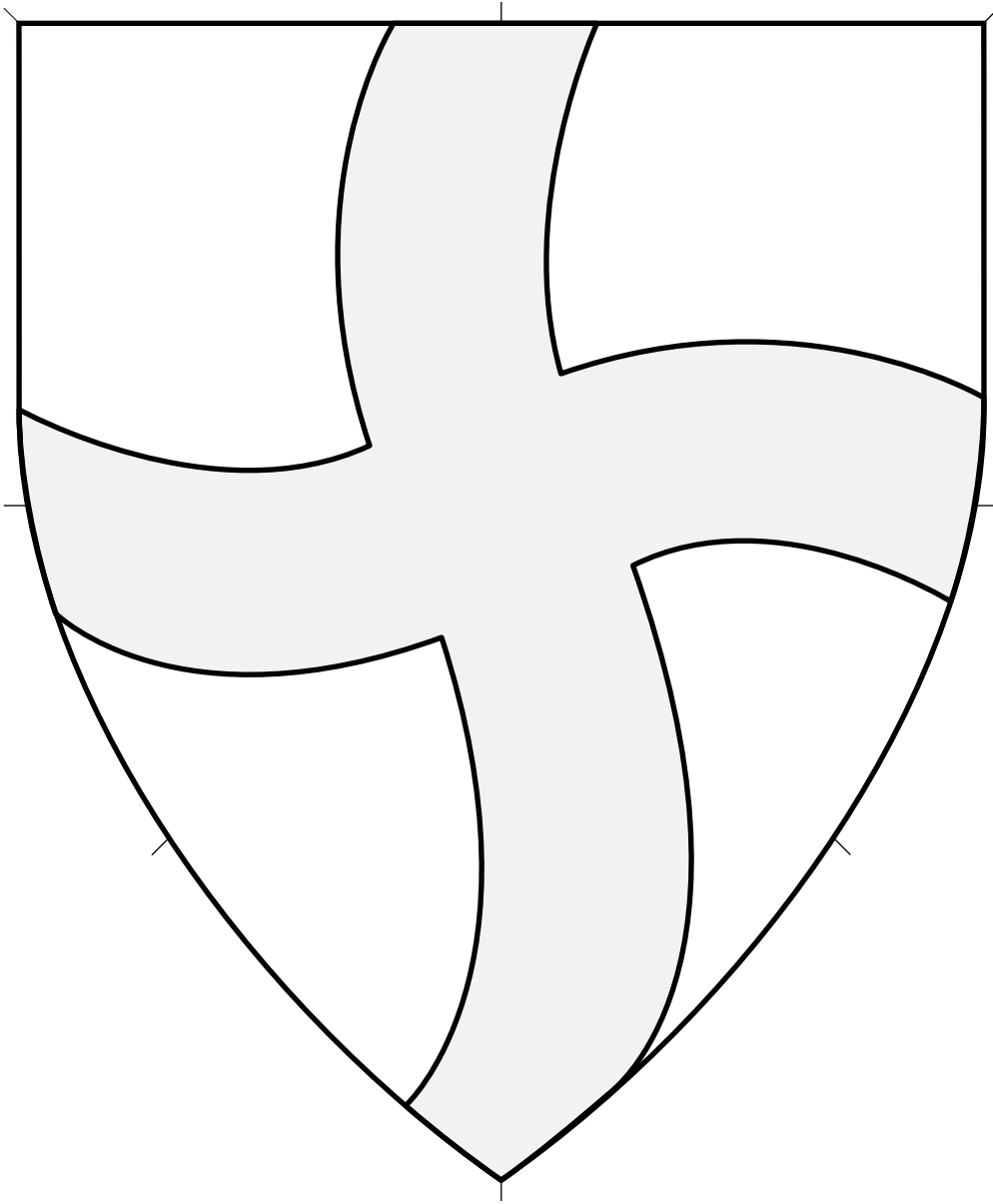

Central ordinary.

Cross Arrondi • 4.347

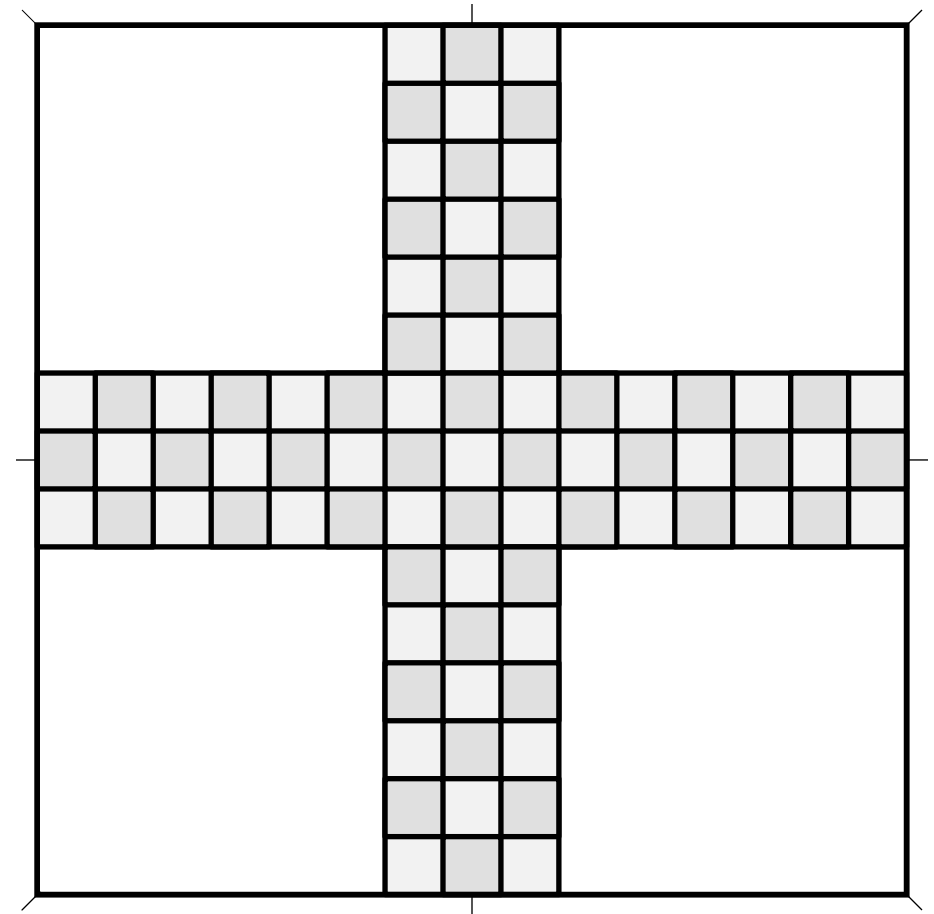
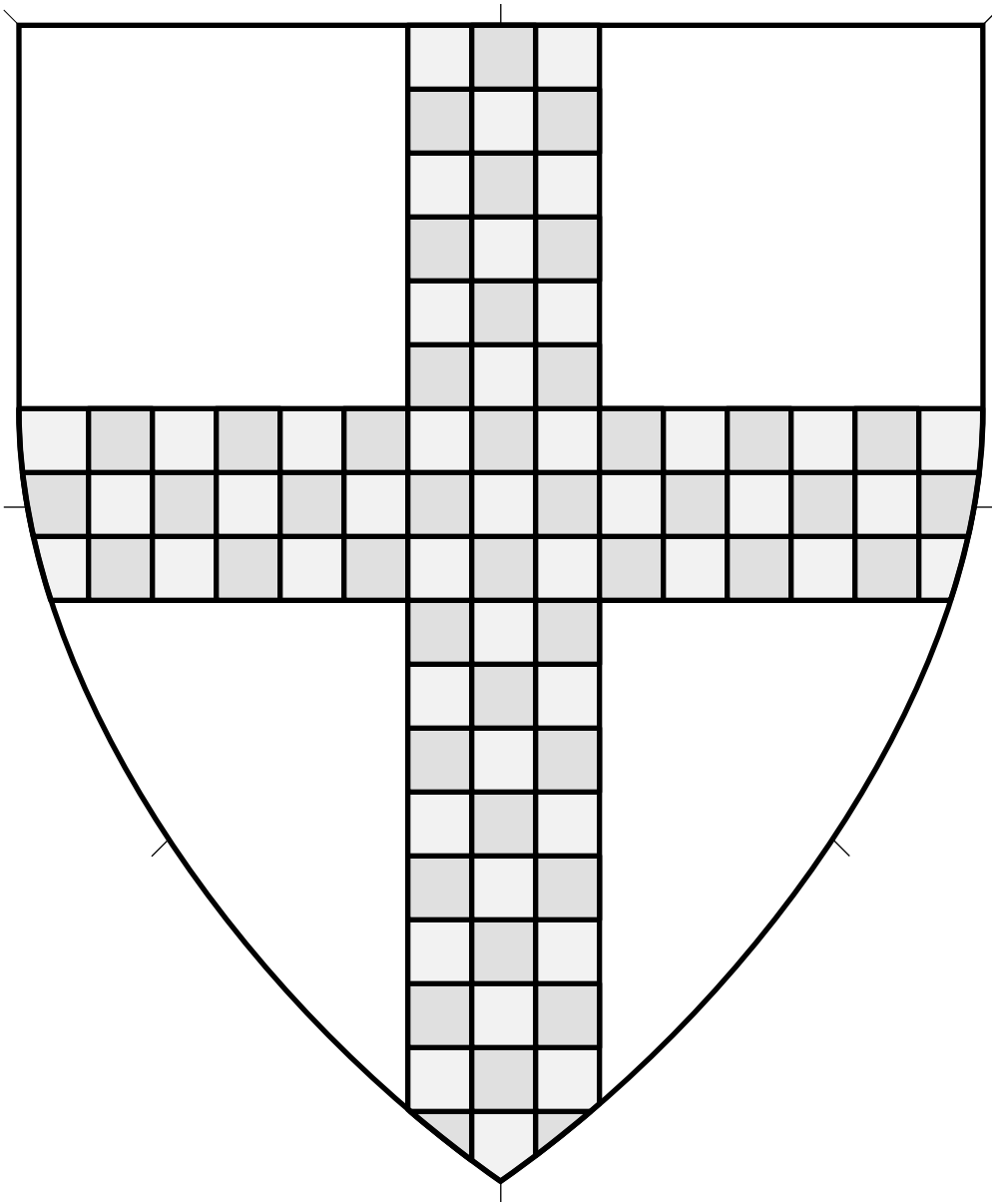

Central ordinary.

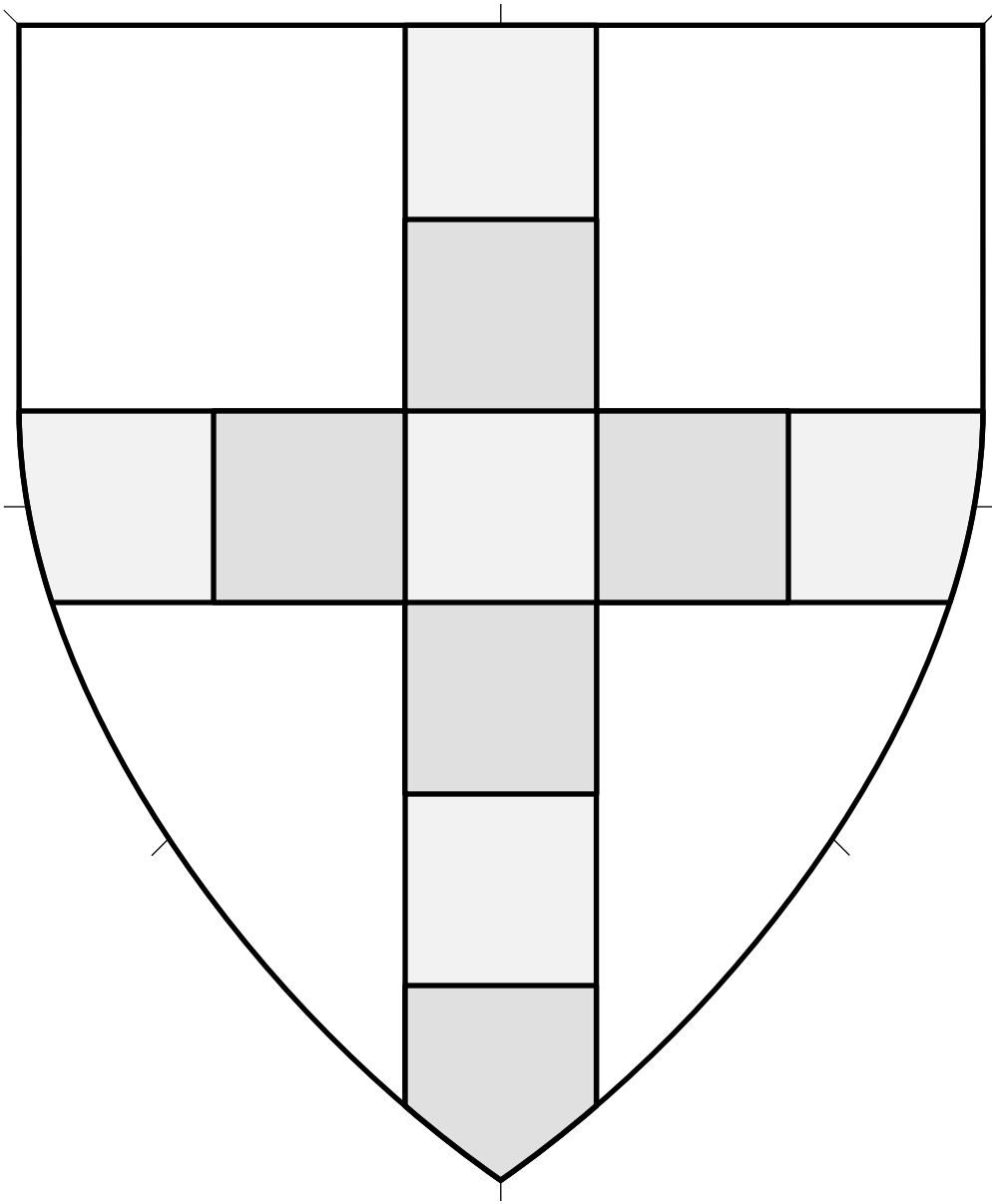

Central ordinary.

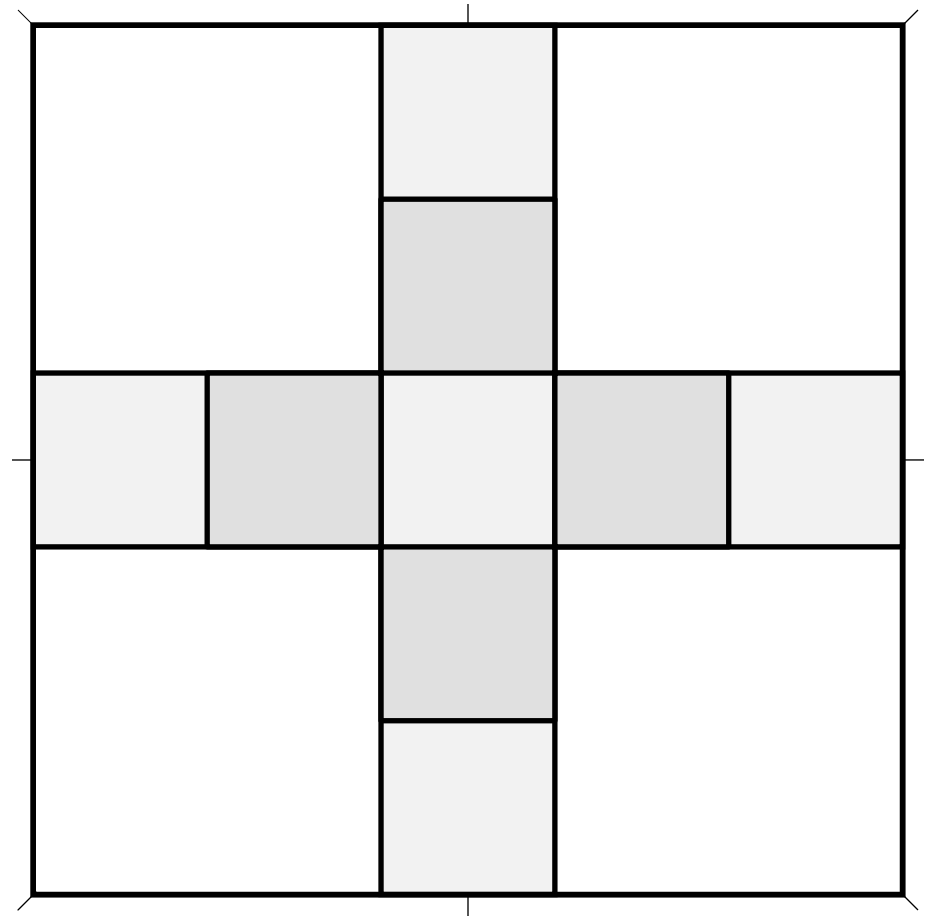

Cross Compony 4.349

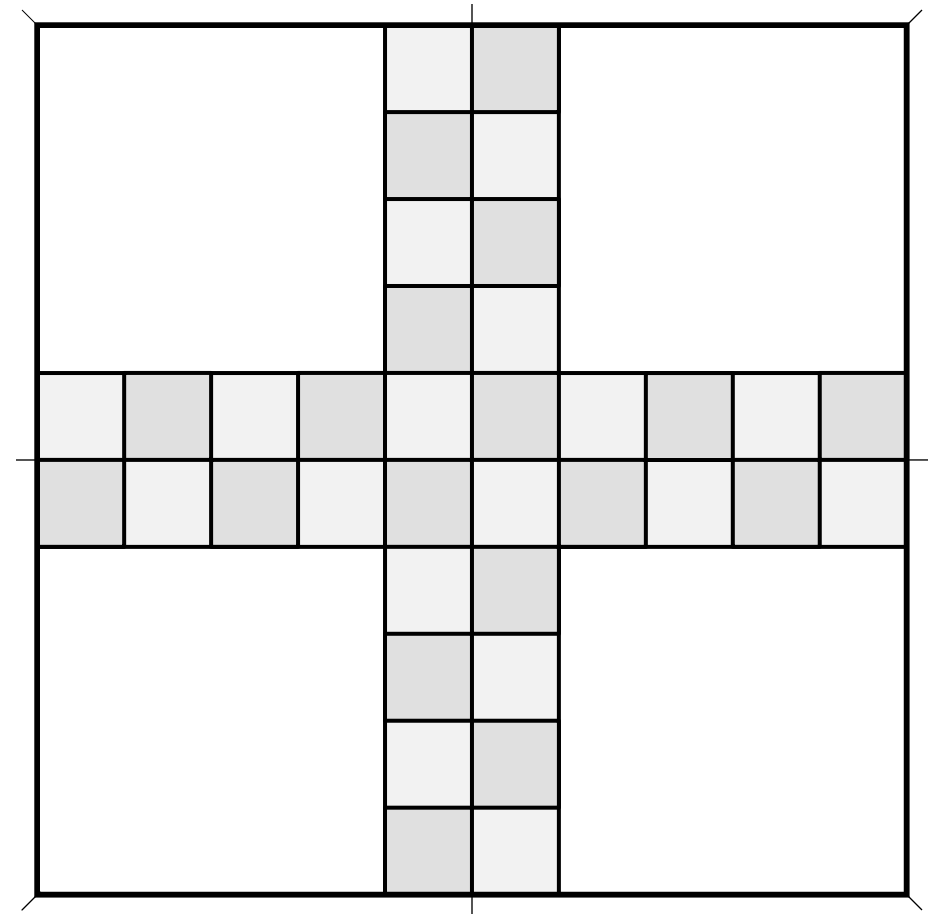
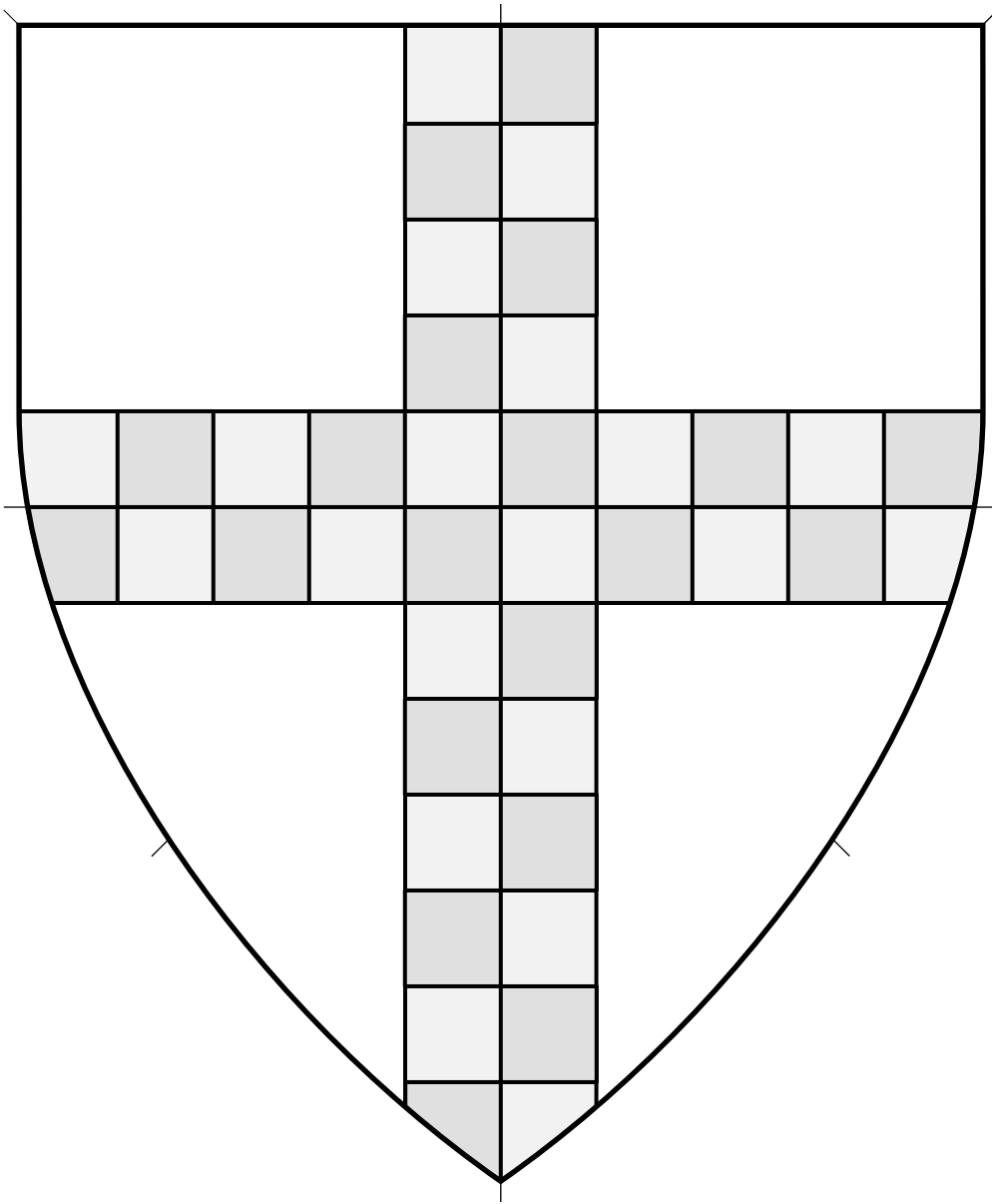

Central ordinary.

Cross Counter-compony (1) 4.350

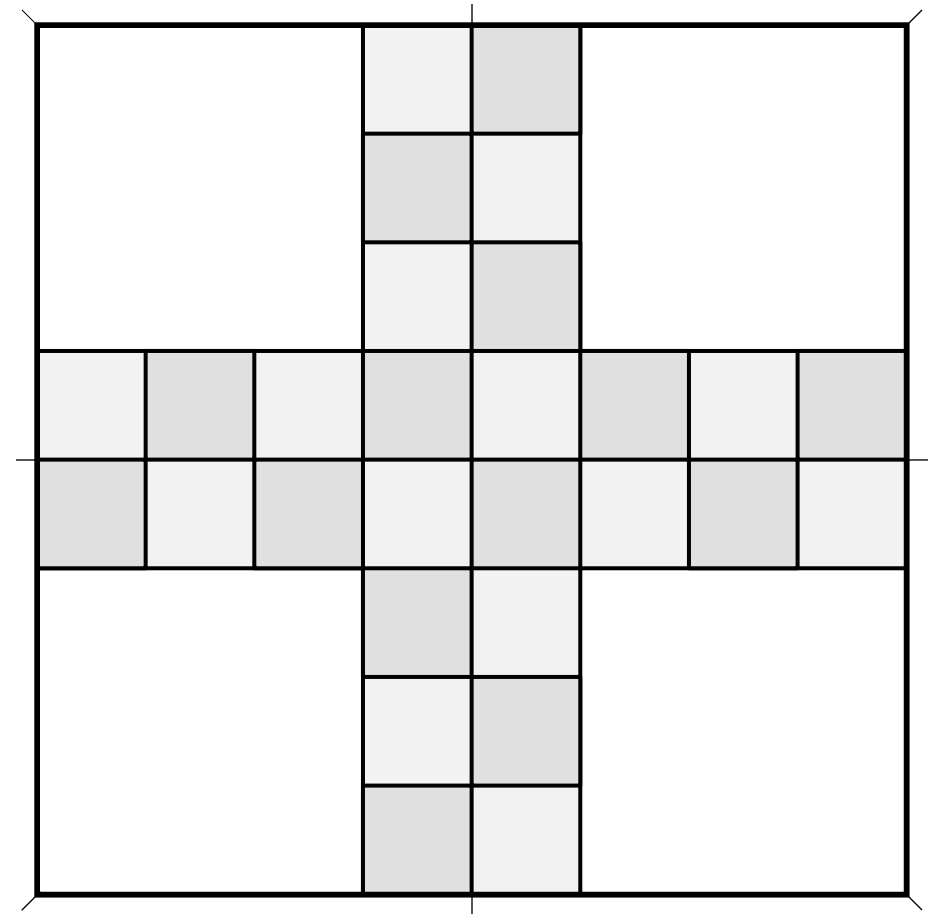
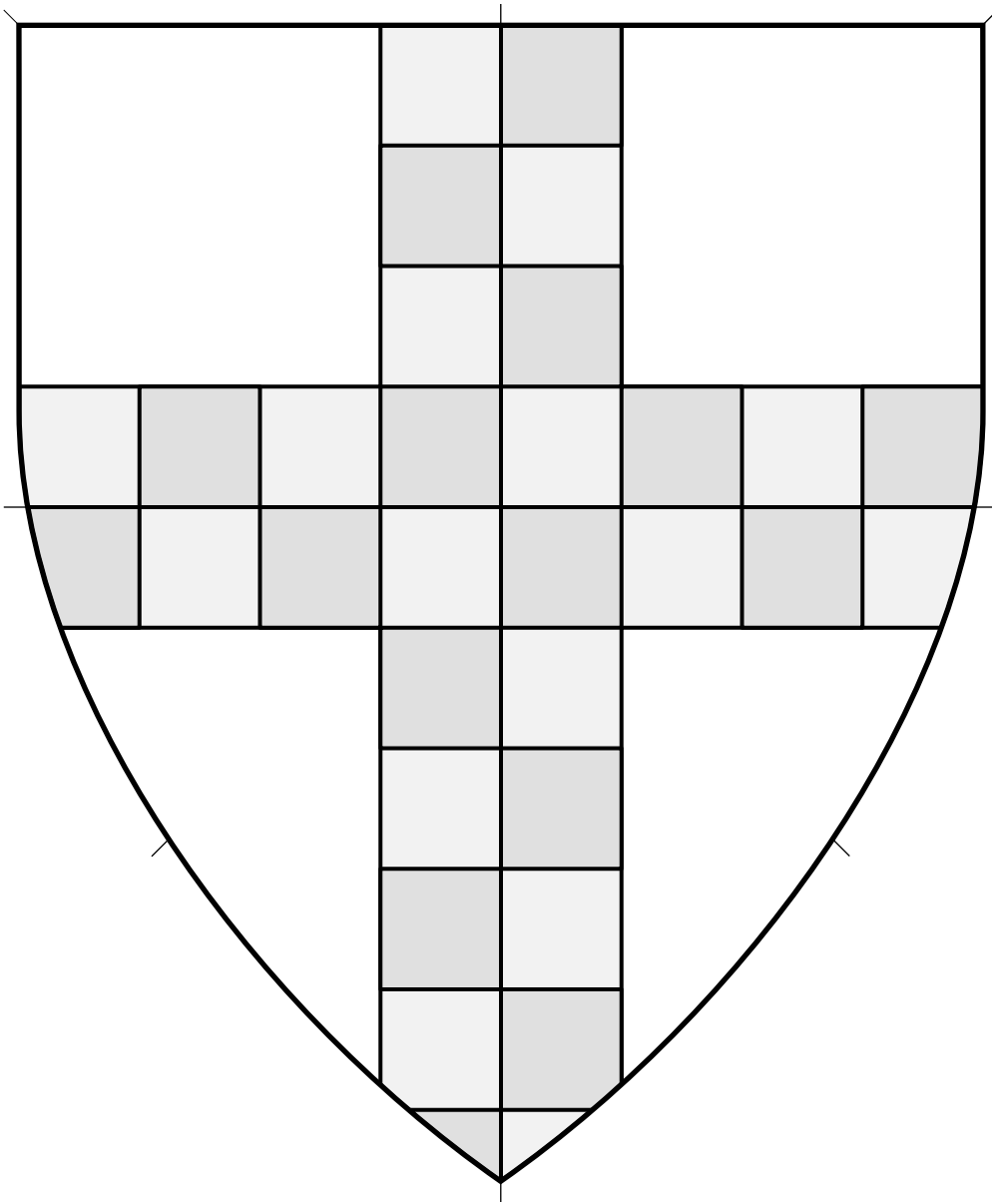

Central ordinary.

Cross Counter-compony (2) 4.351

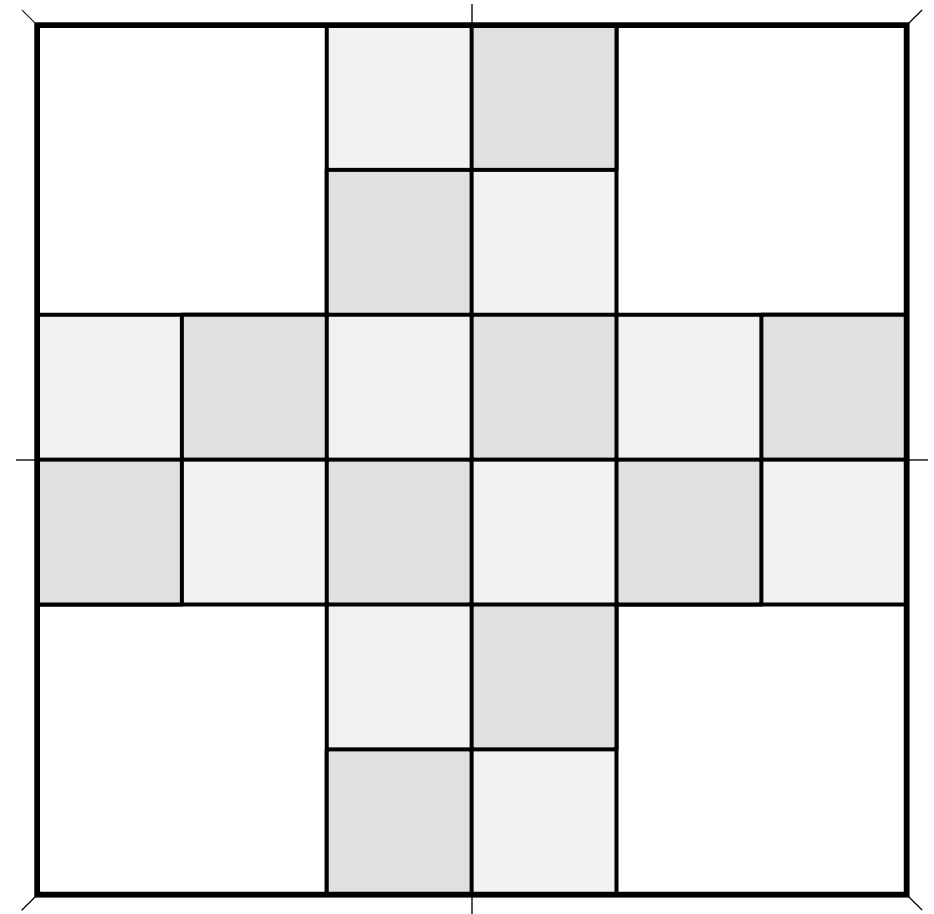
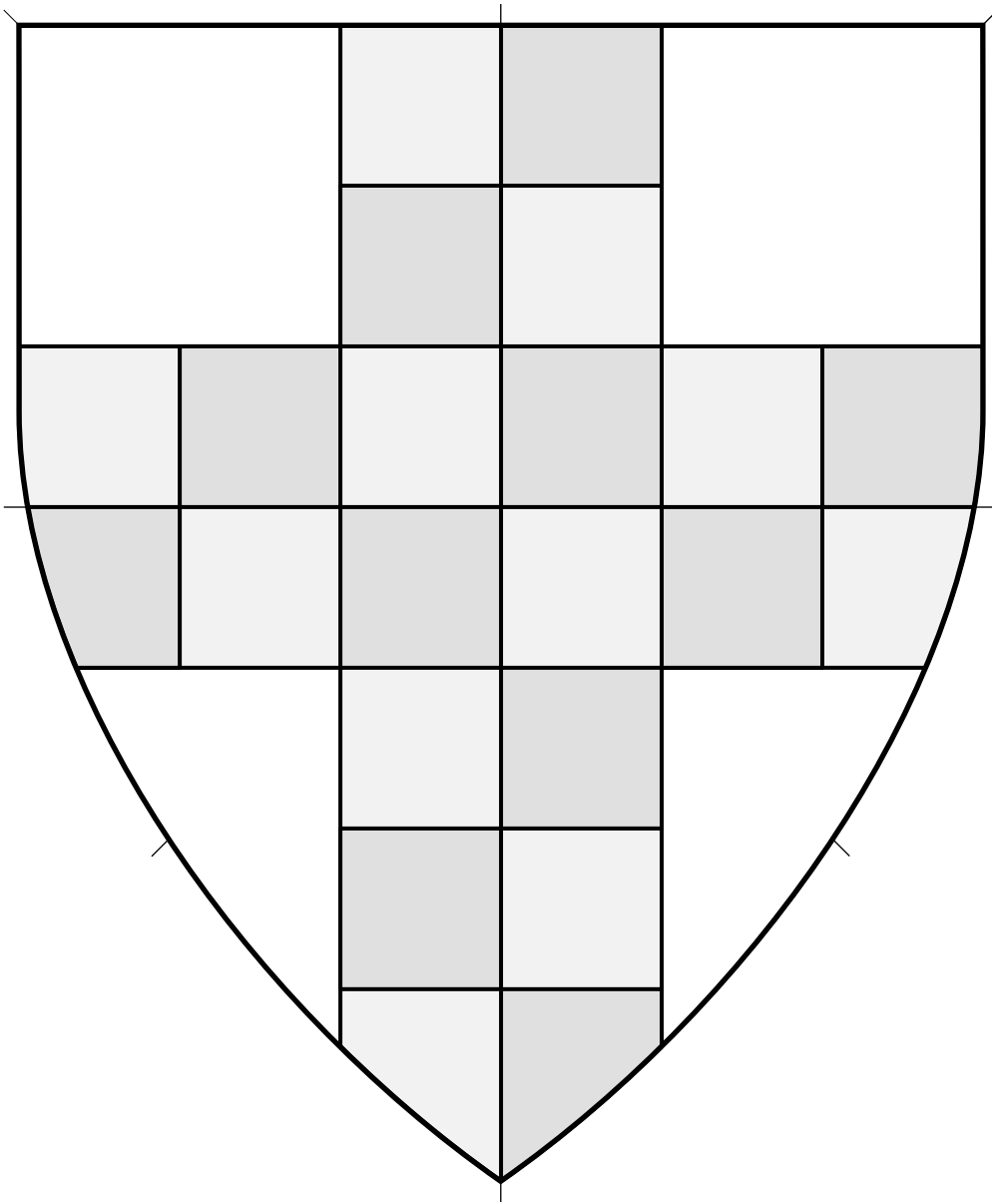

Central ordinary.

Cross Counter-compony (3) 4.352

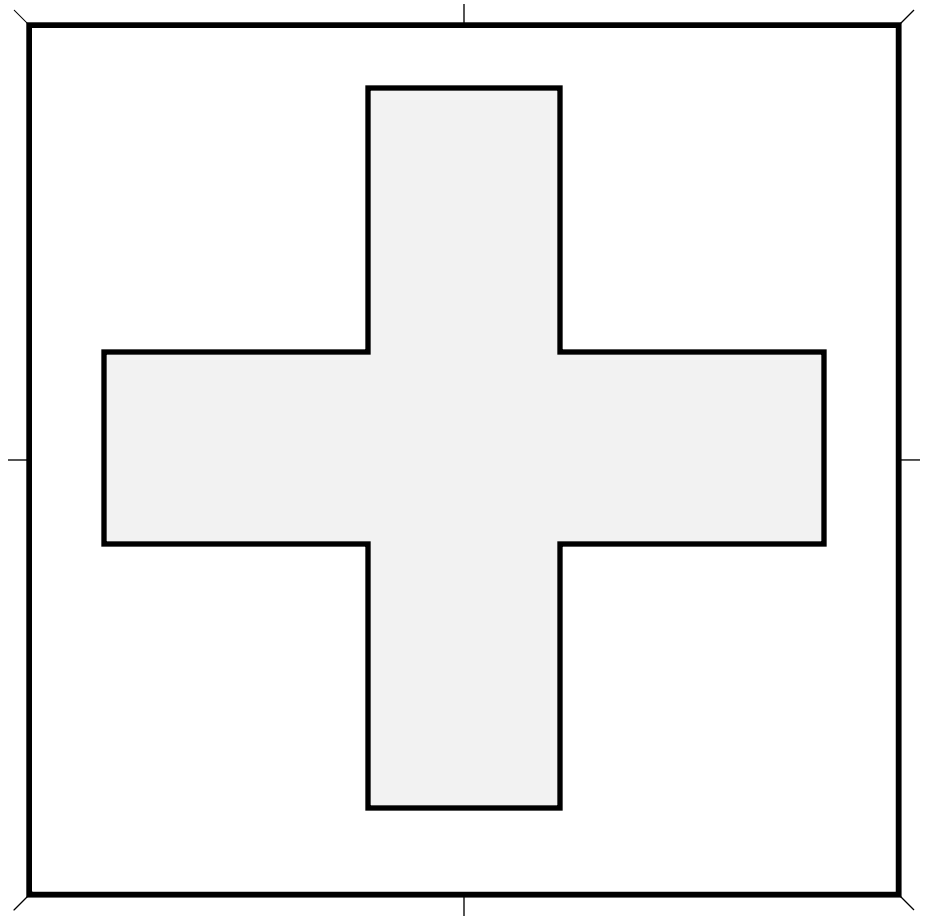
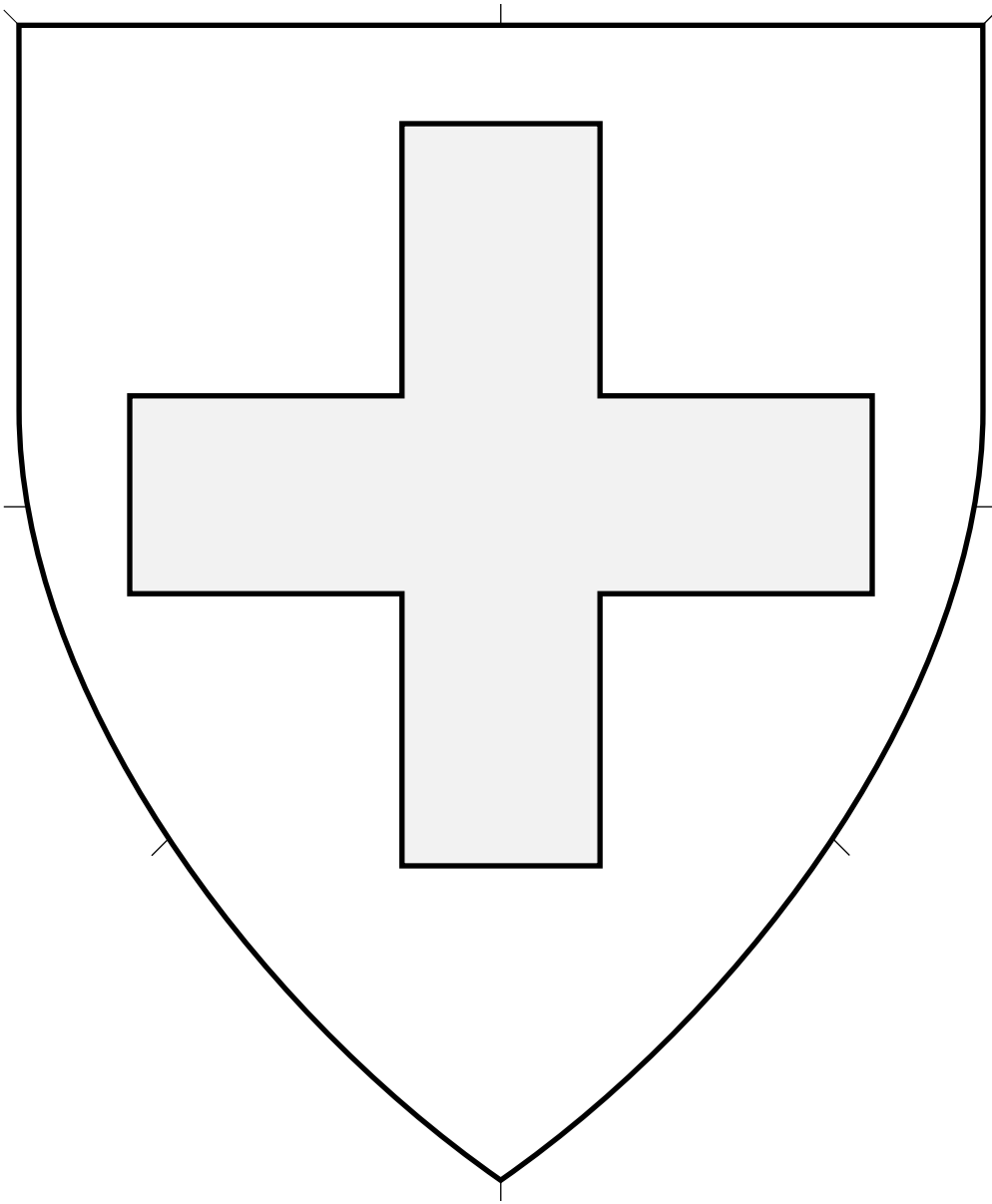

A couped cross, or a bar and a pale conjoined that do not reach the edges of the field.
Use of a cross gules on an argent field is restricted for conflict with the Red Cross.

Cross Couped (1) • 4.353

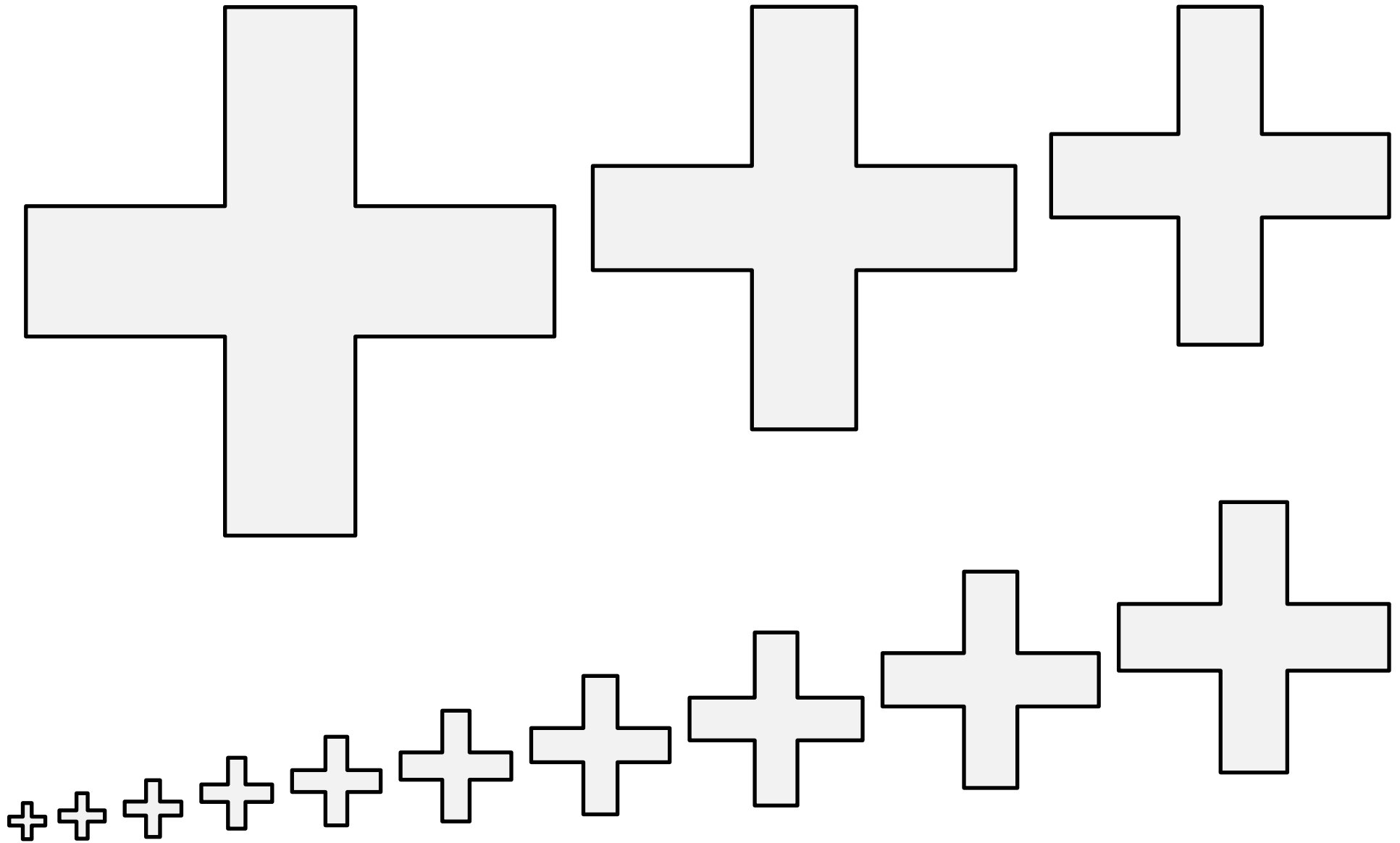

A couped cross, or a bar and a pale conjoined that do not reach the edges of the field.
Use of a cross gules on an argent field is restricted for conflict with the Red Cross.

Cross Couped (2) 4.354

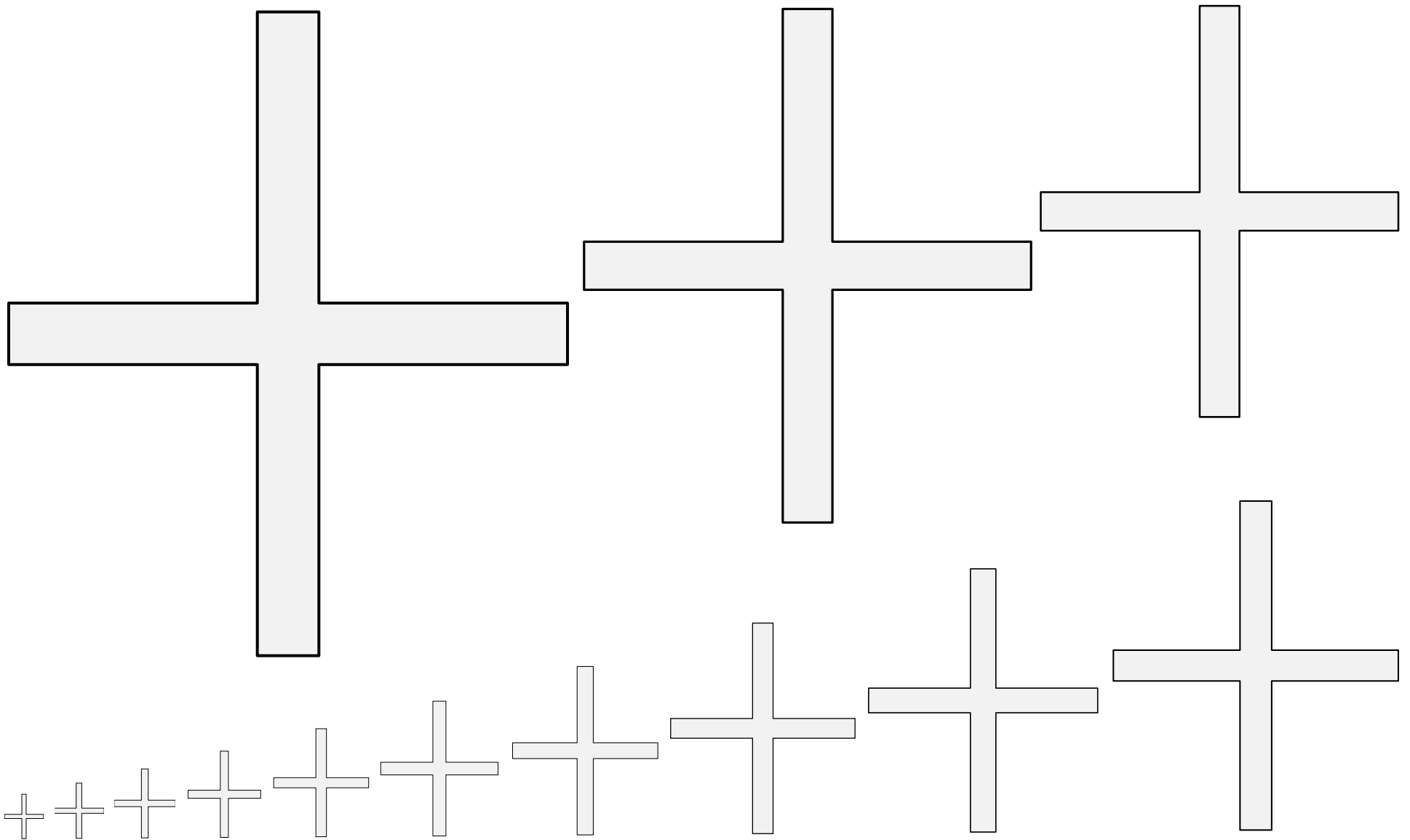

A couped cross, or a bar and a pale conjoined that do not reach the edges of the field.

Source: English Arms A. Artist unknown. (Page 89.)

Cross Couped (3) • 4.355

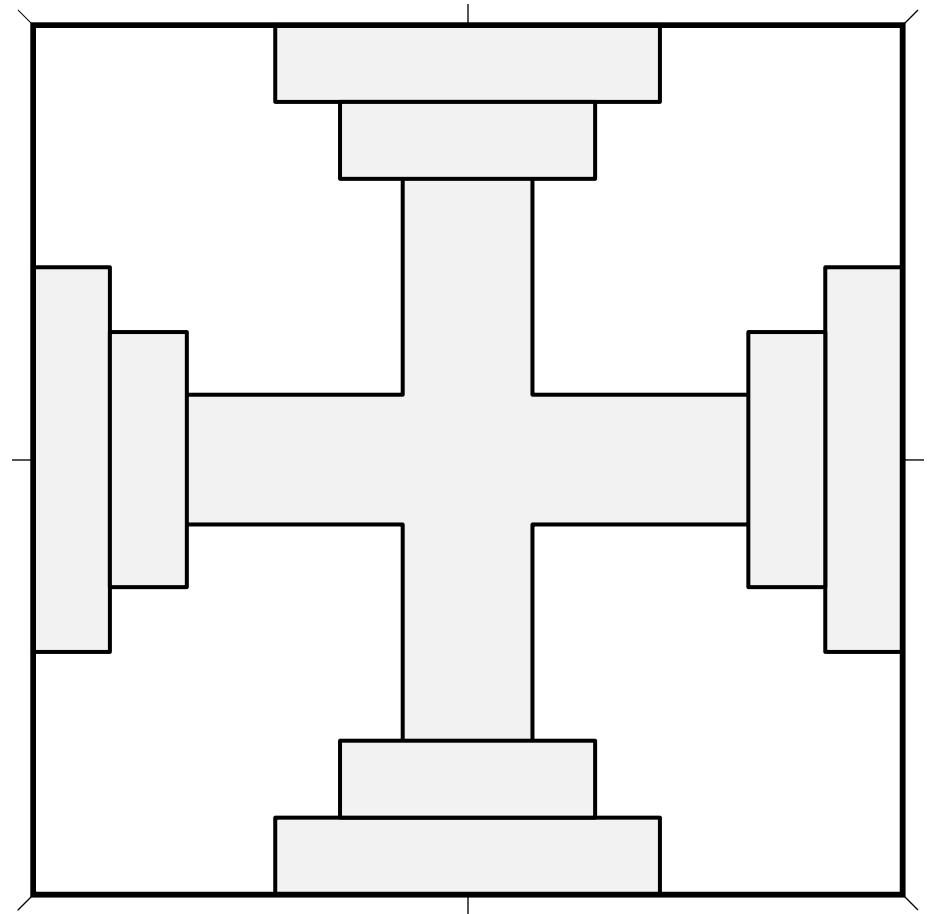
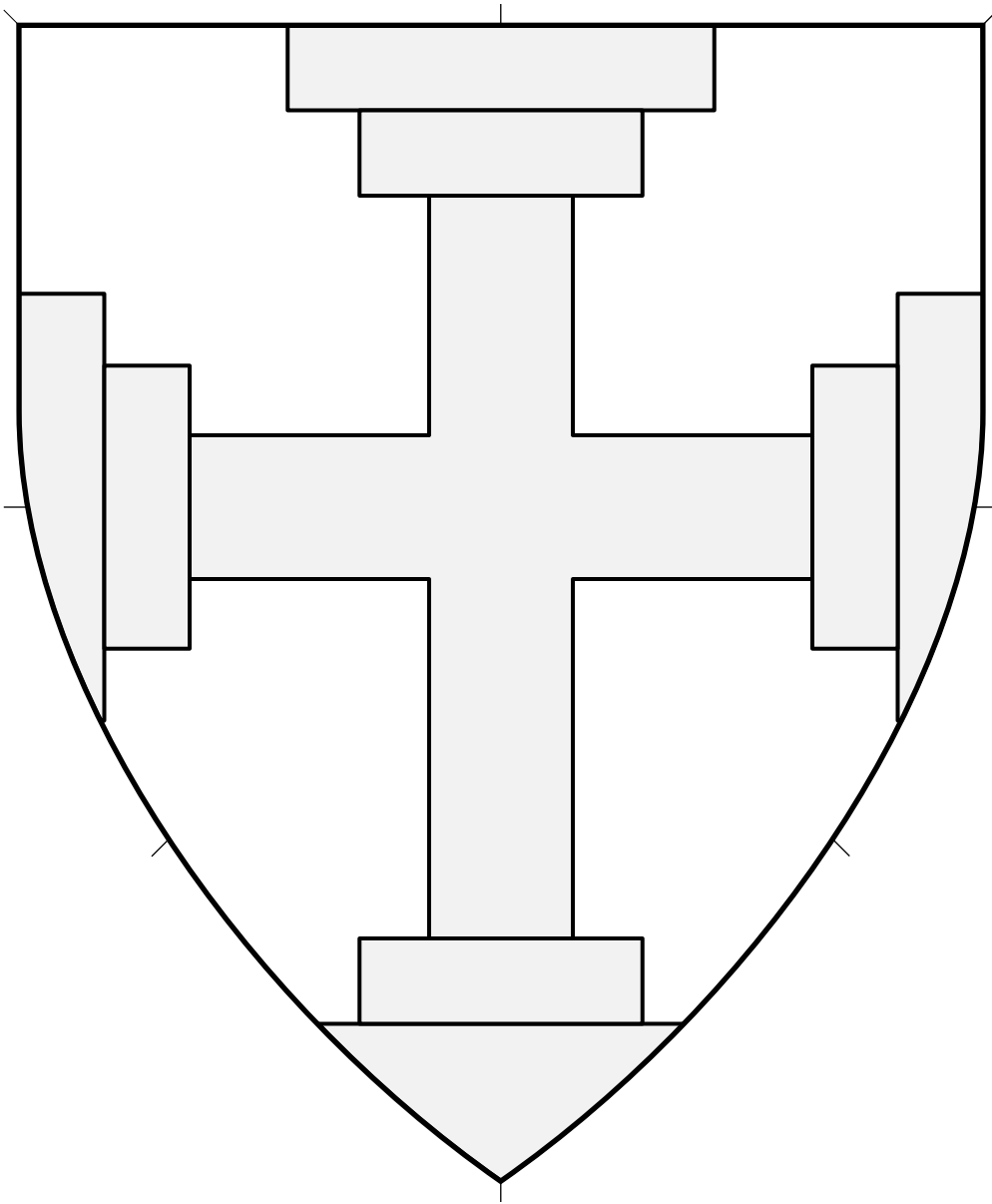

Central ordinary.

Source: A Glossary of Terms Used in Heraldry.
Artist: James or Irene Parker. (Arms of Wyntworth.)

Cross Degraded 4.356

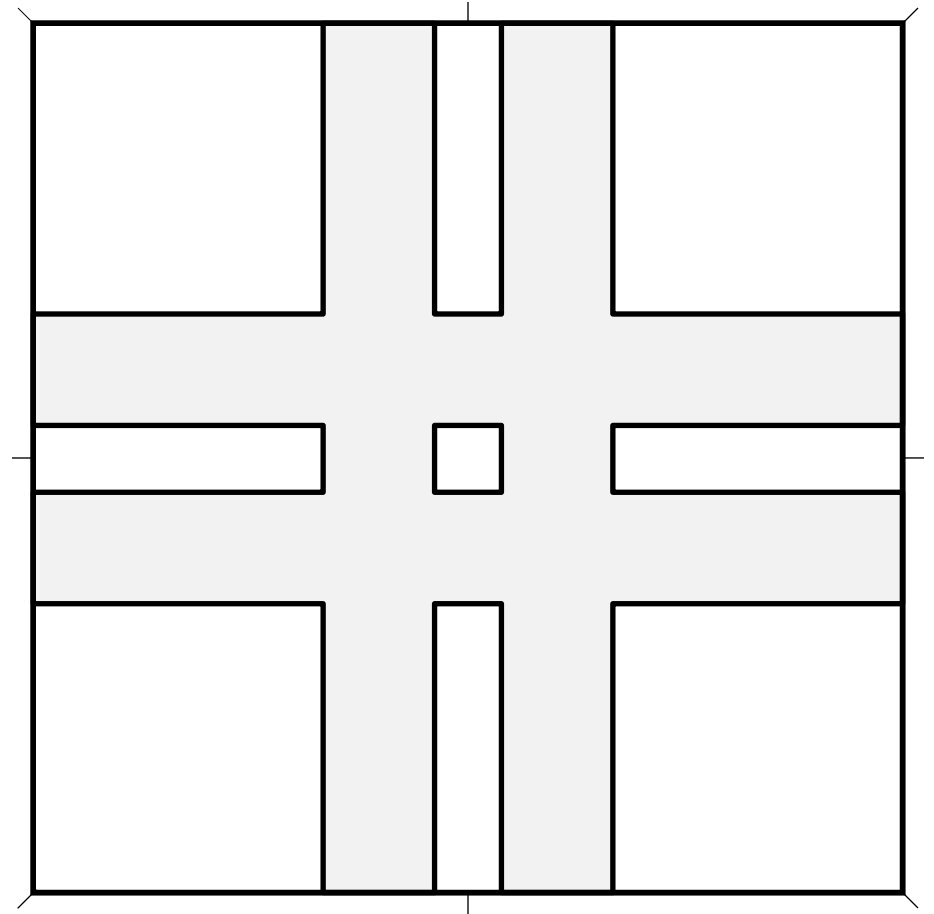
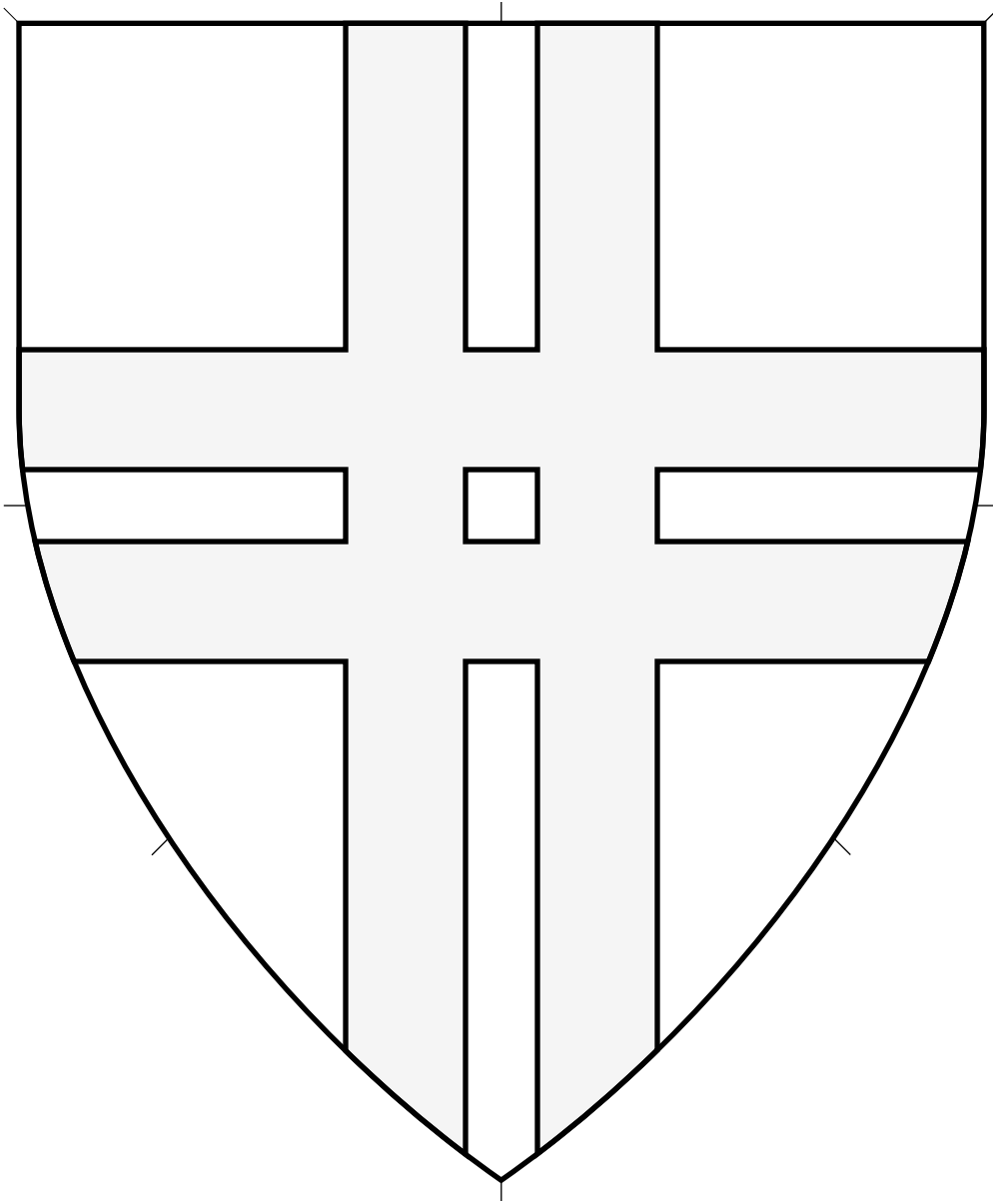

Central ordinary. A cross formed of two bars and two pales, conjoined.

Cross Double Parted 4.357

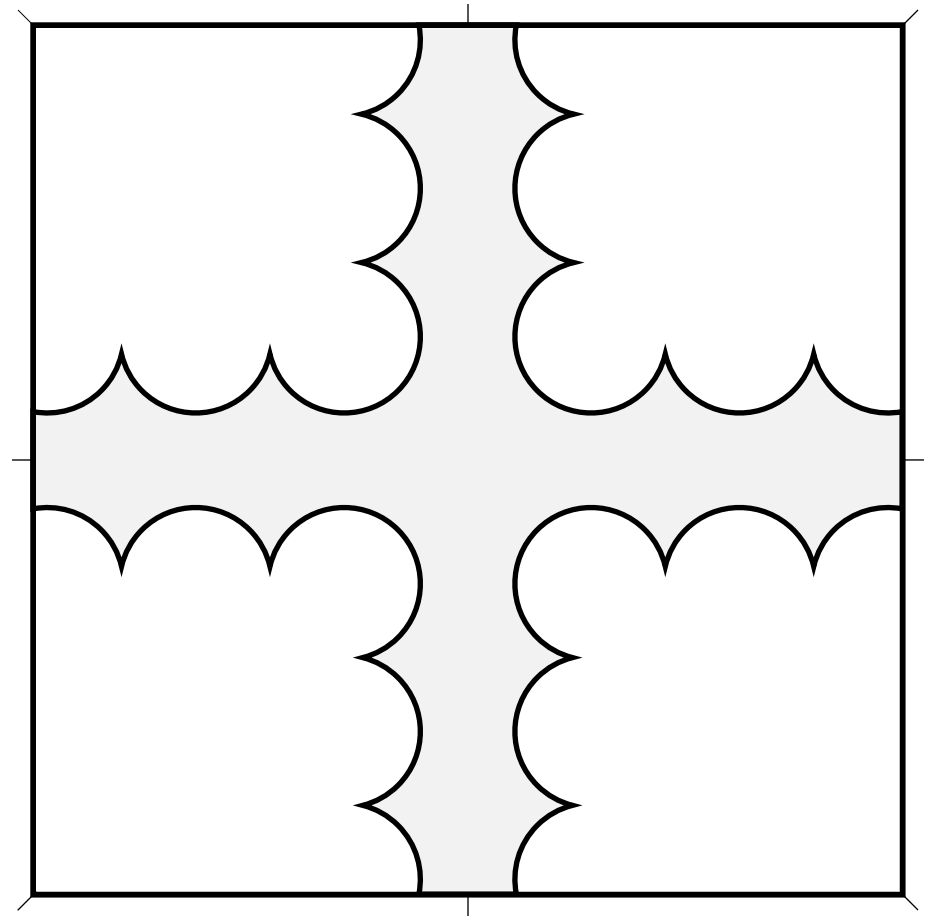
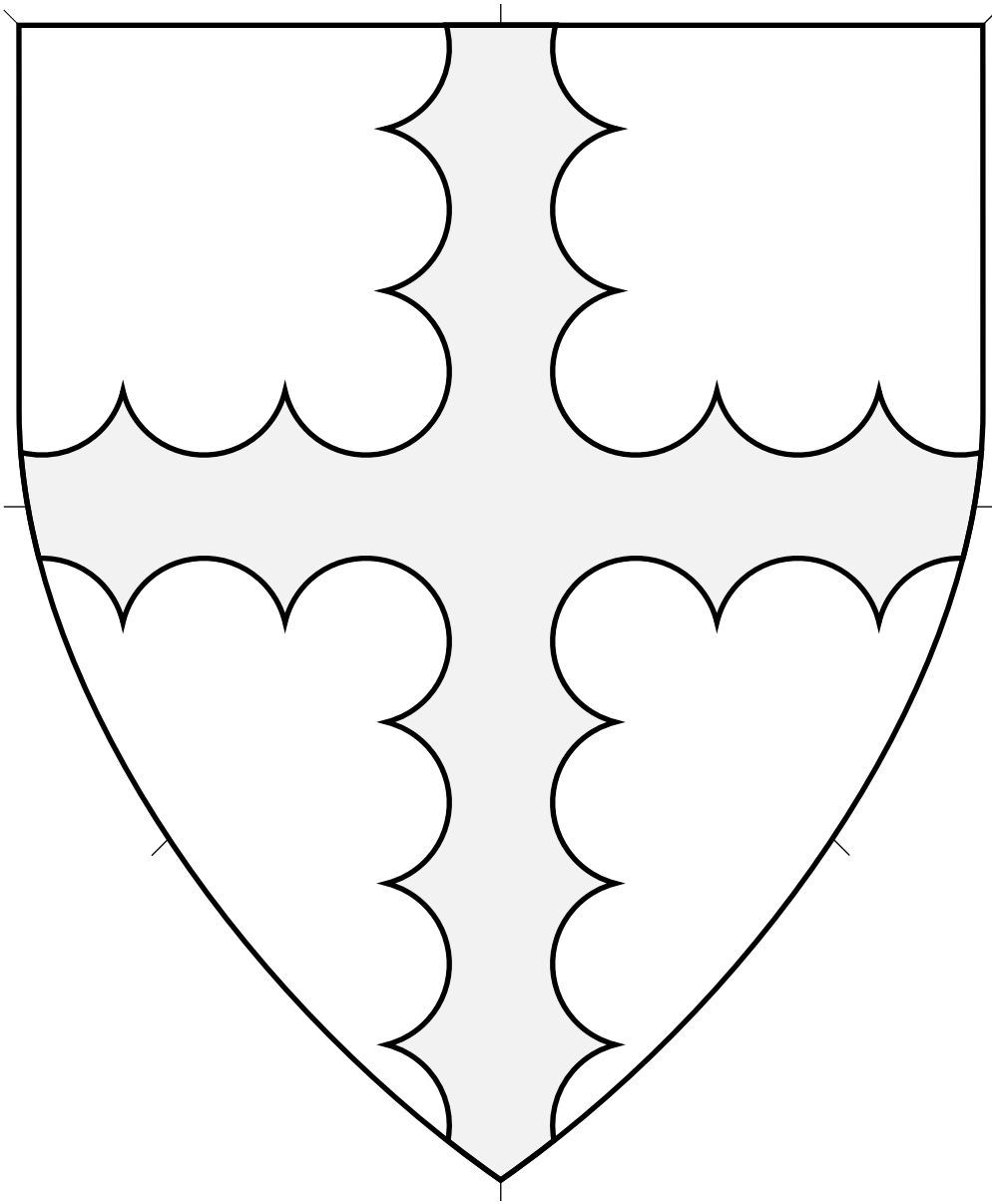

Central ordinary.

Source: Powell Roll. Artist unknown. (Folio 3r, arms of Ufford.)

Cross Engrailed (1) 4.358

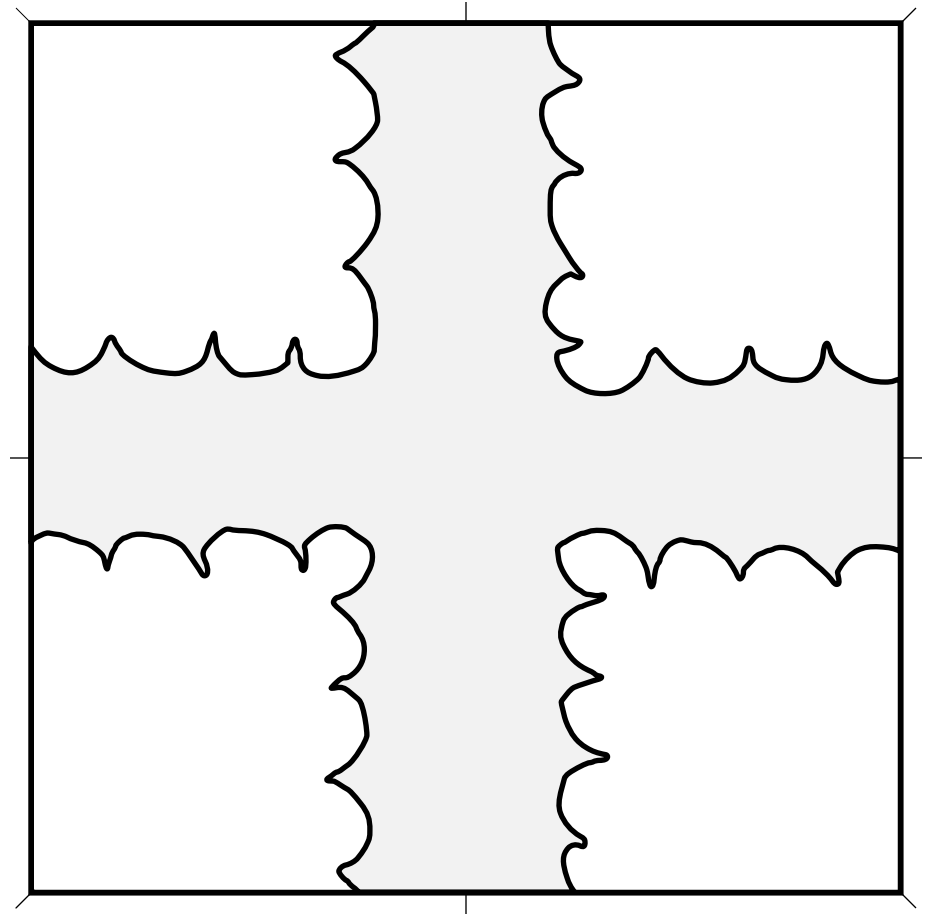
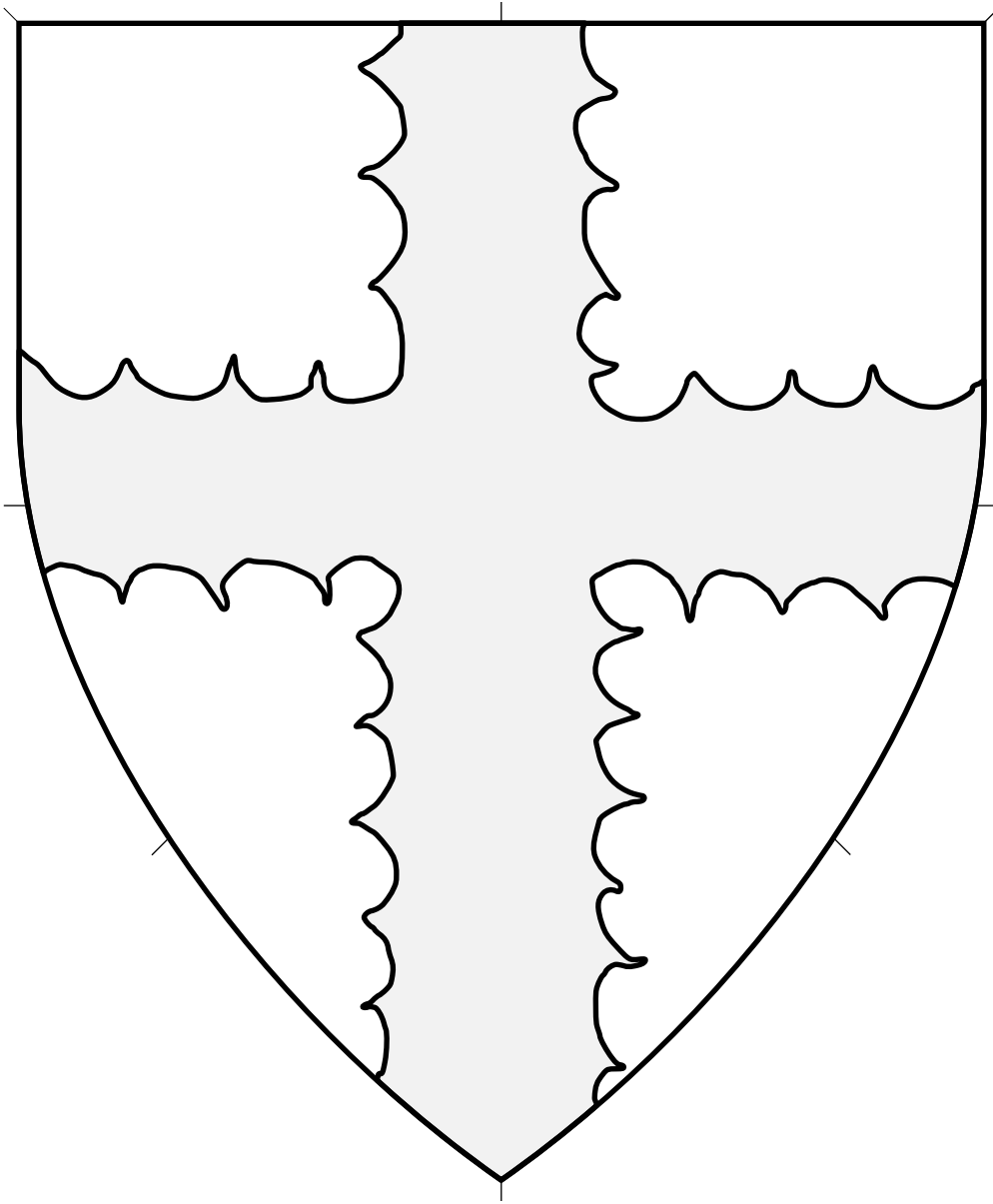

Central ordinary.

Source: Manchester University English MS 15. Artist unknown. (Folio 22v.)

Cross Engrailed (2) 4.359

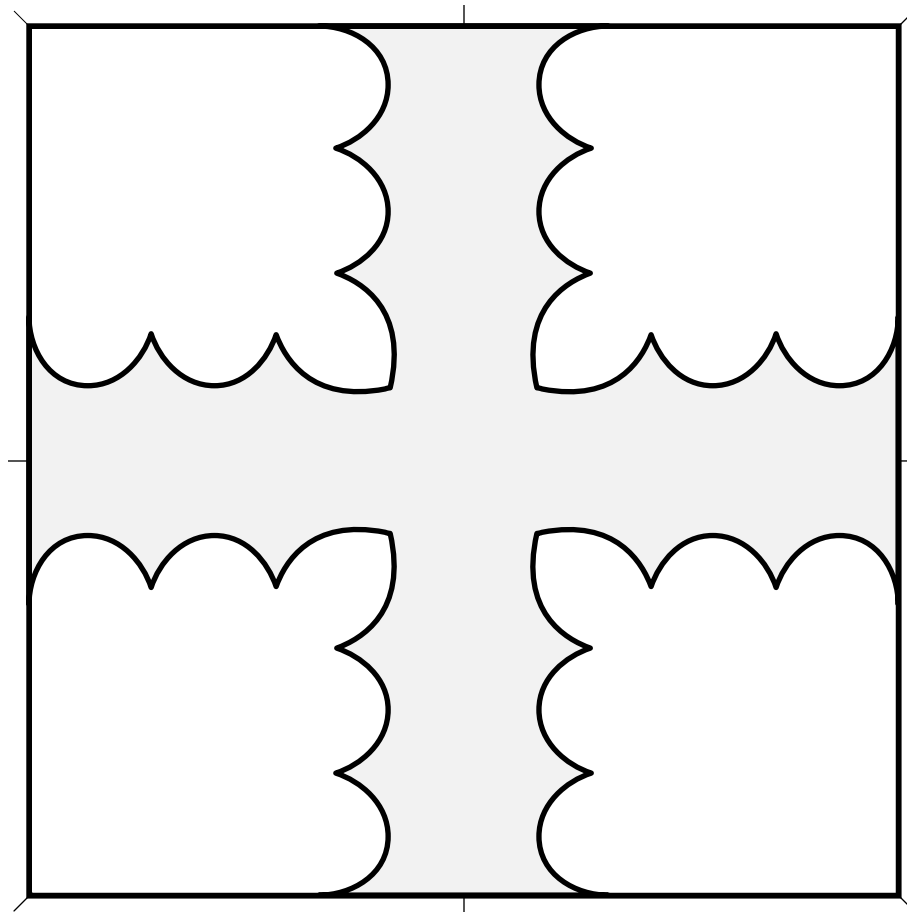
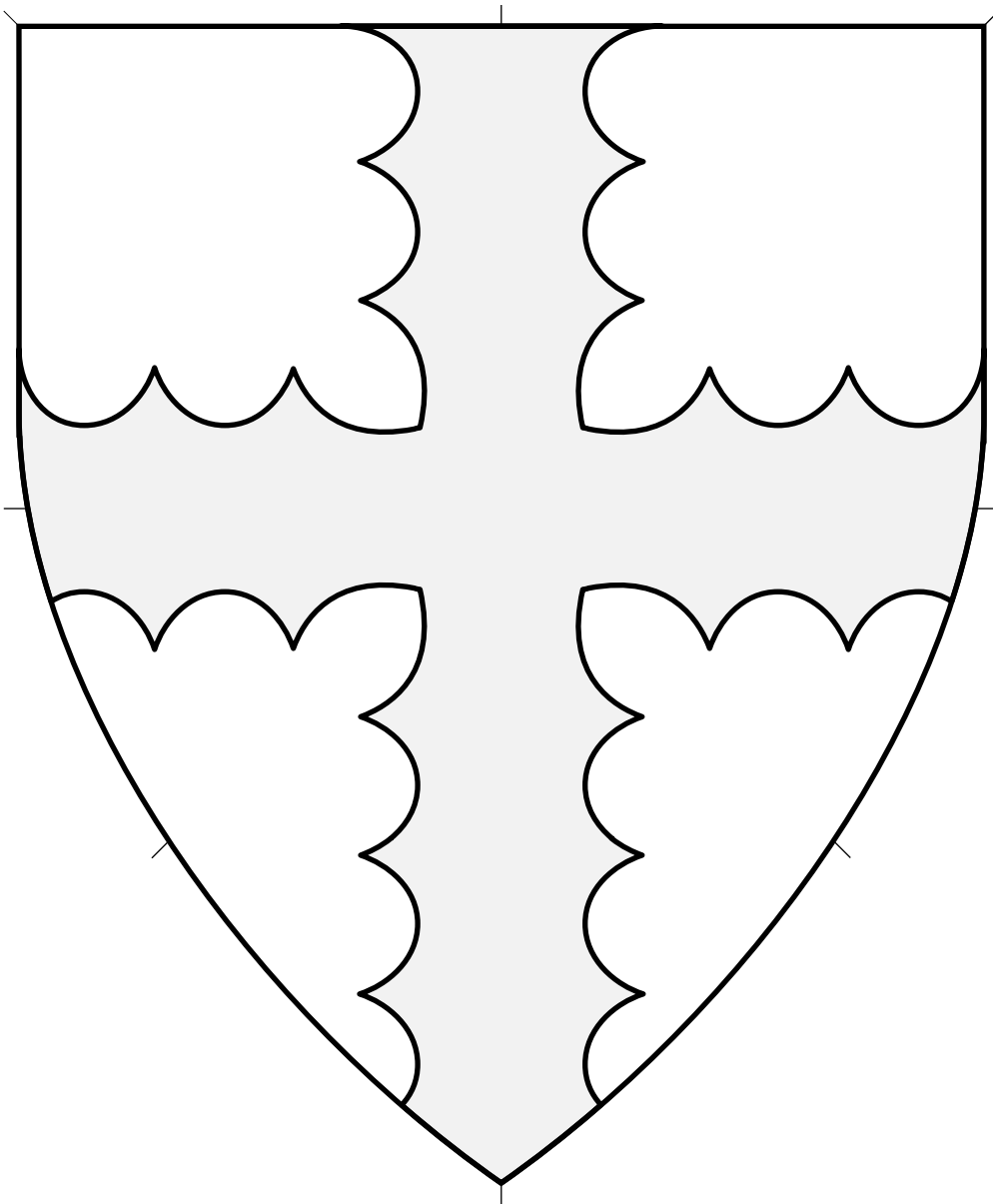

Central ordinary.

Source: WappenWiki. Artist: Joakim Spuller.

Cross Engrailed (3) • 4.360

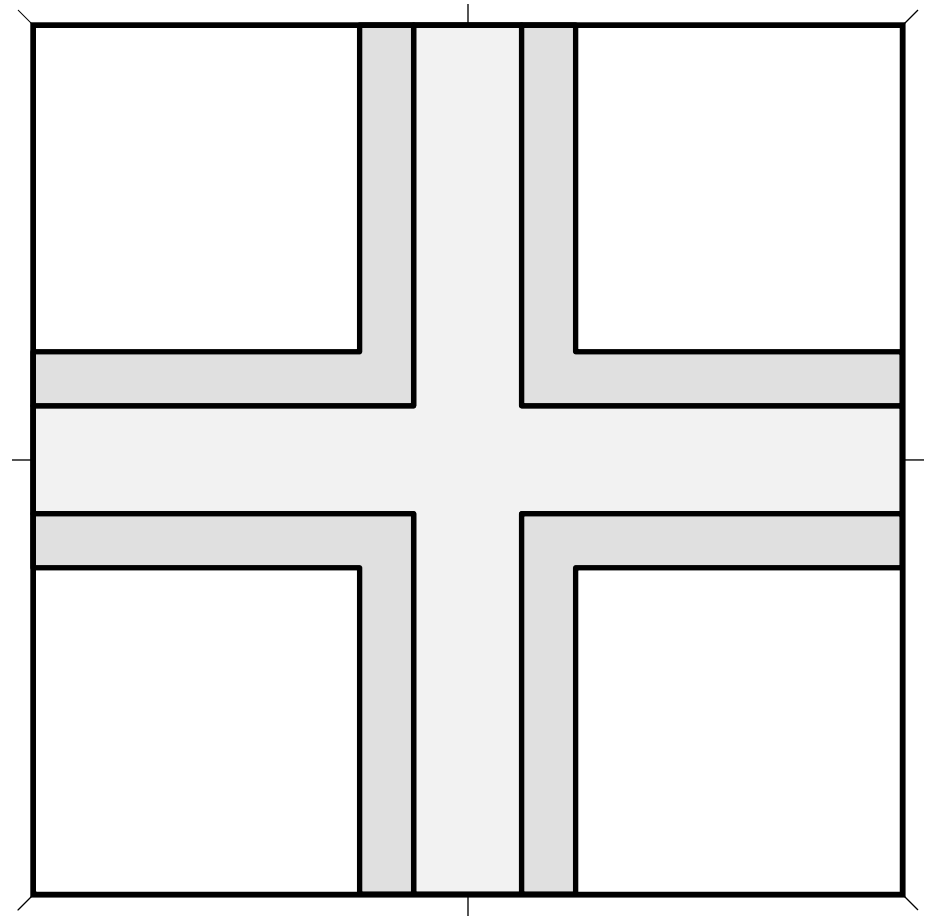
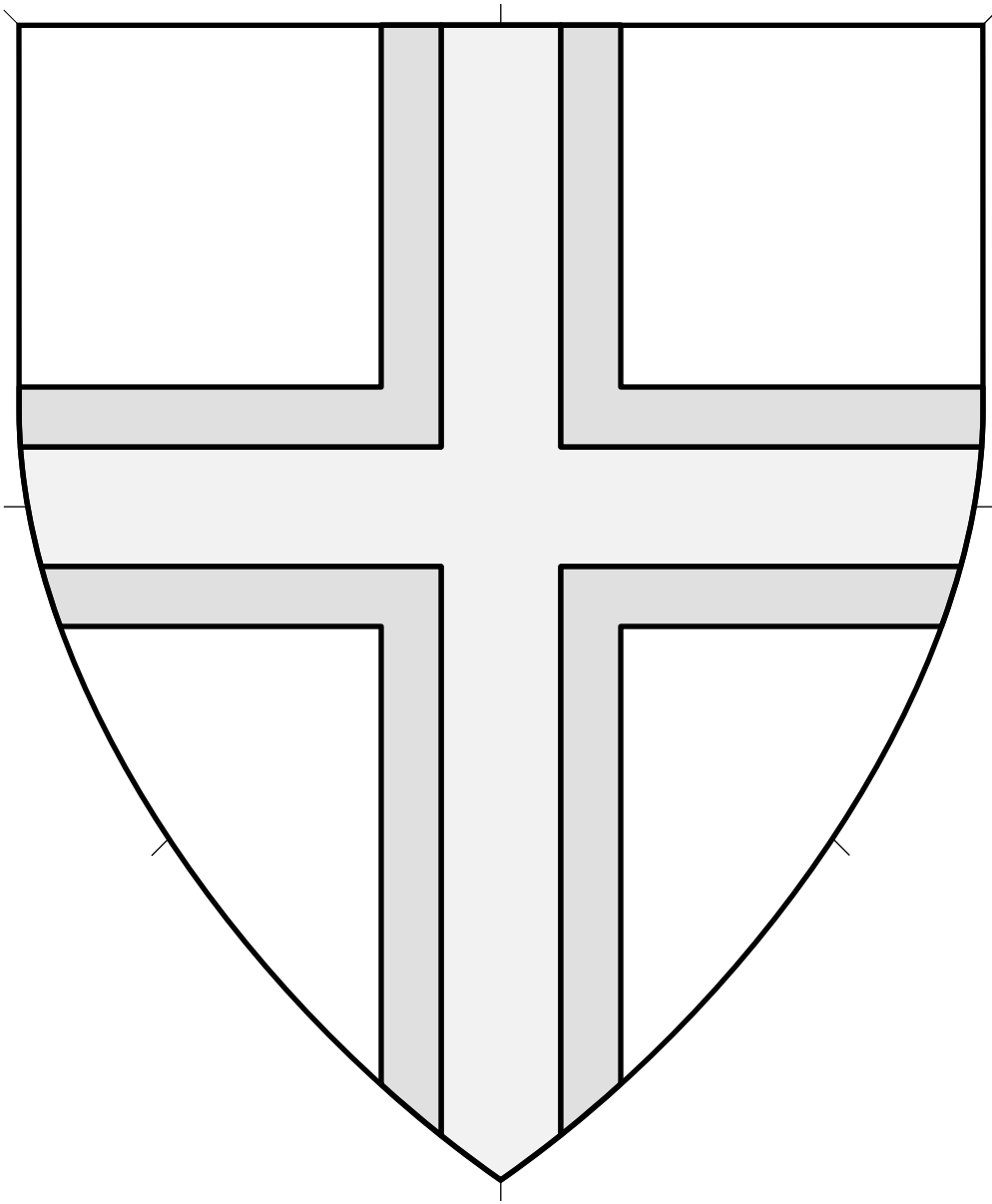

Central ordinary.

Source: English Arms A. Artist unknown. (Page 75.)

Cross Fimbriated (1) 4.361

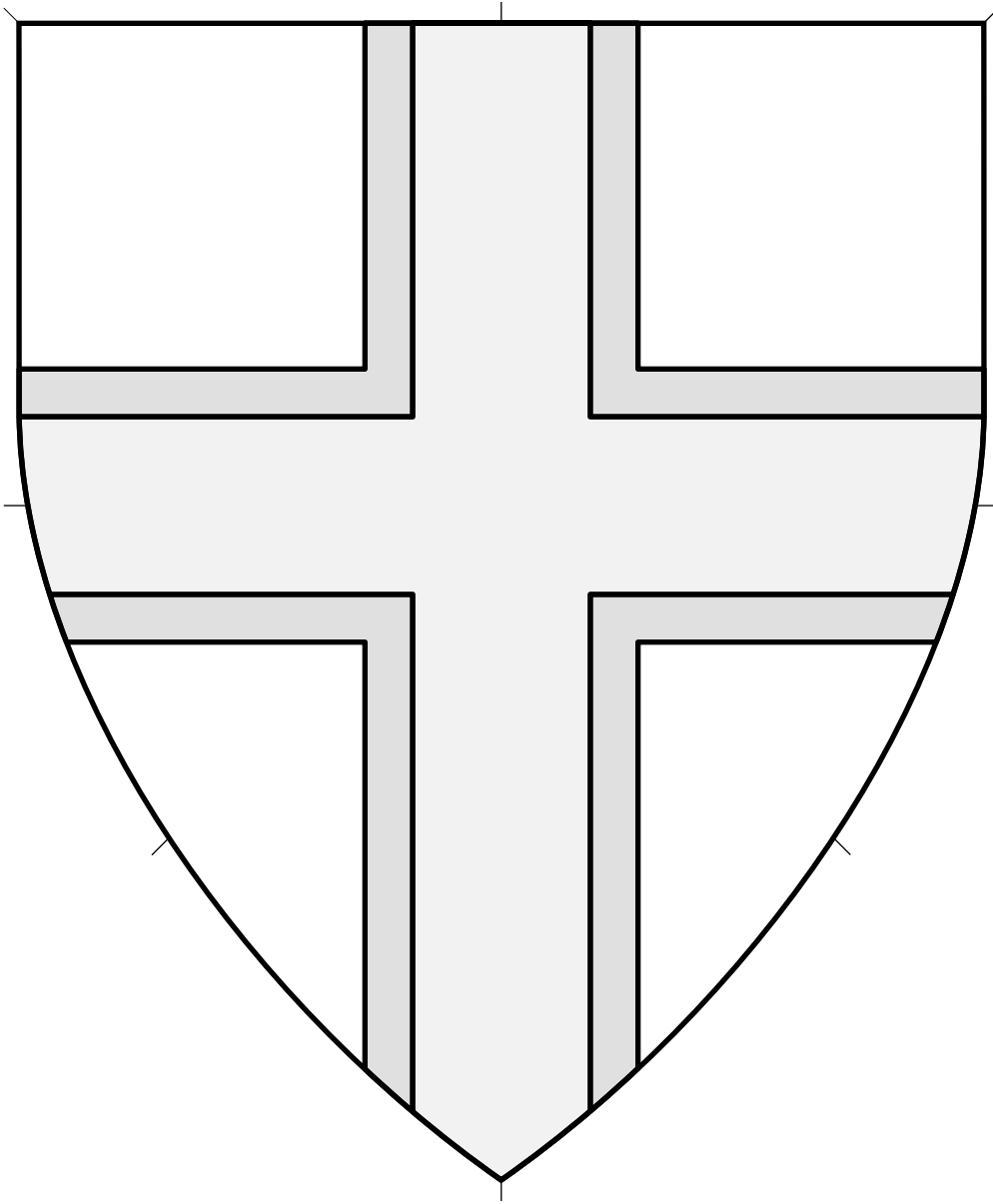

Central ordinary.

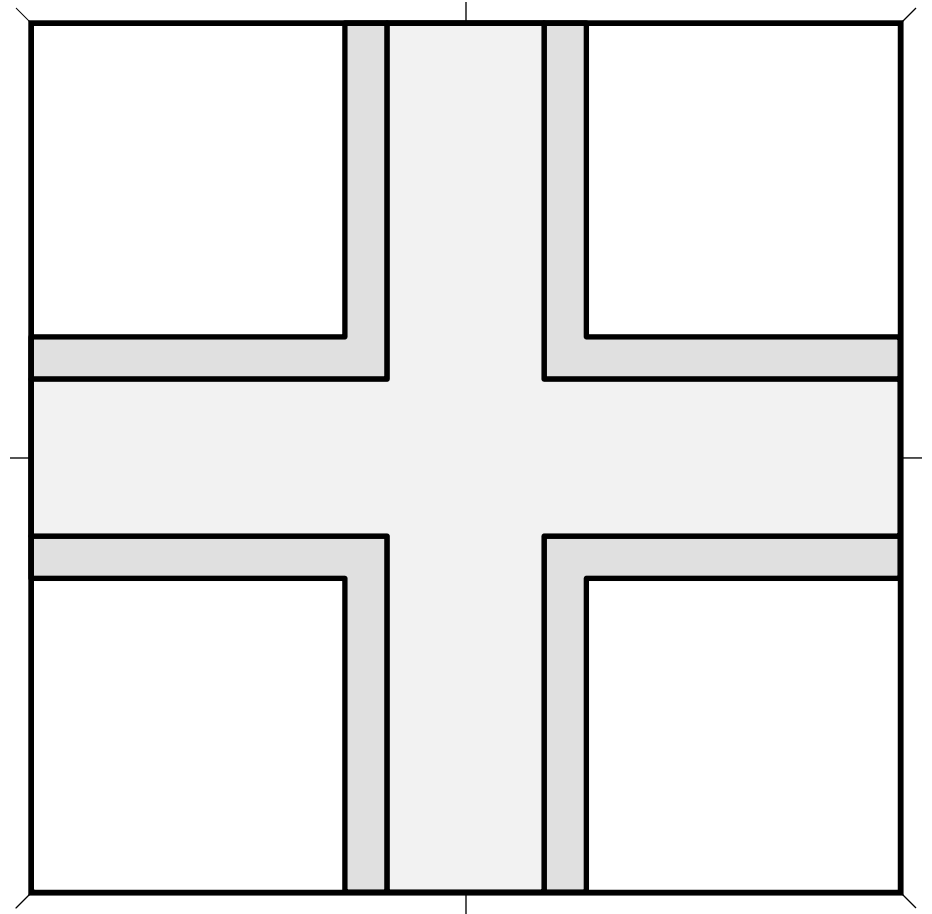

Cross Fimbriated (2) 4.362

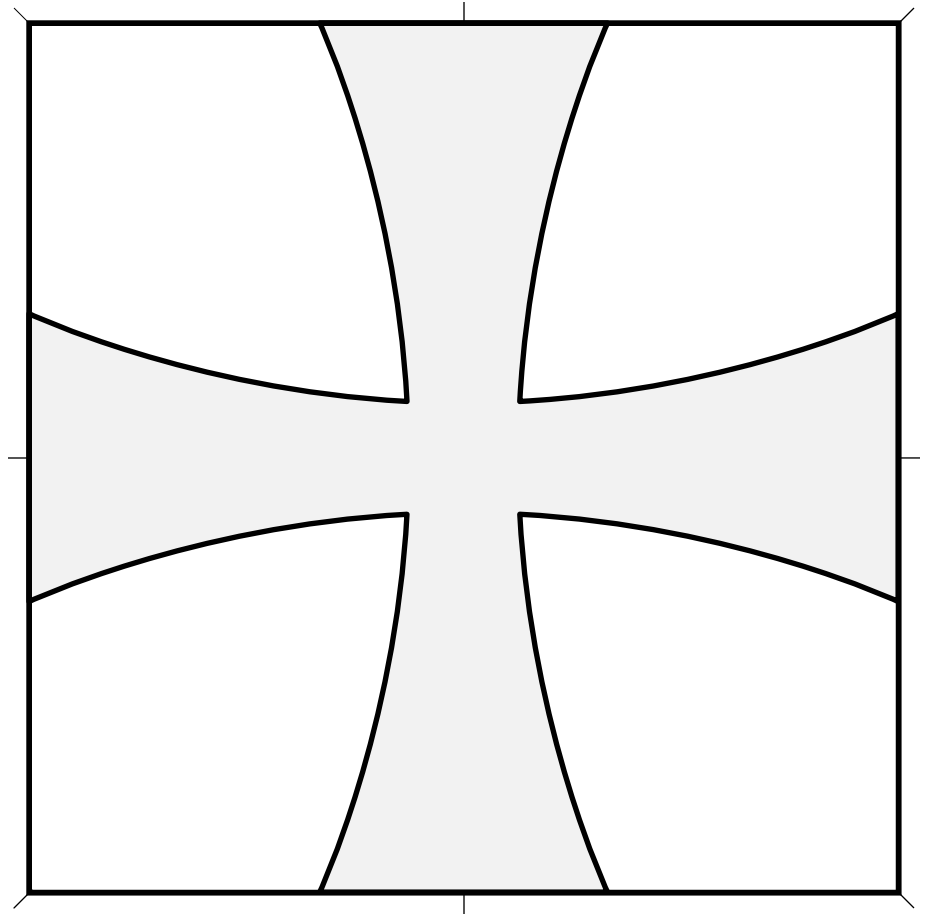
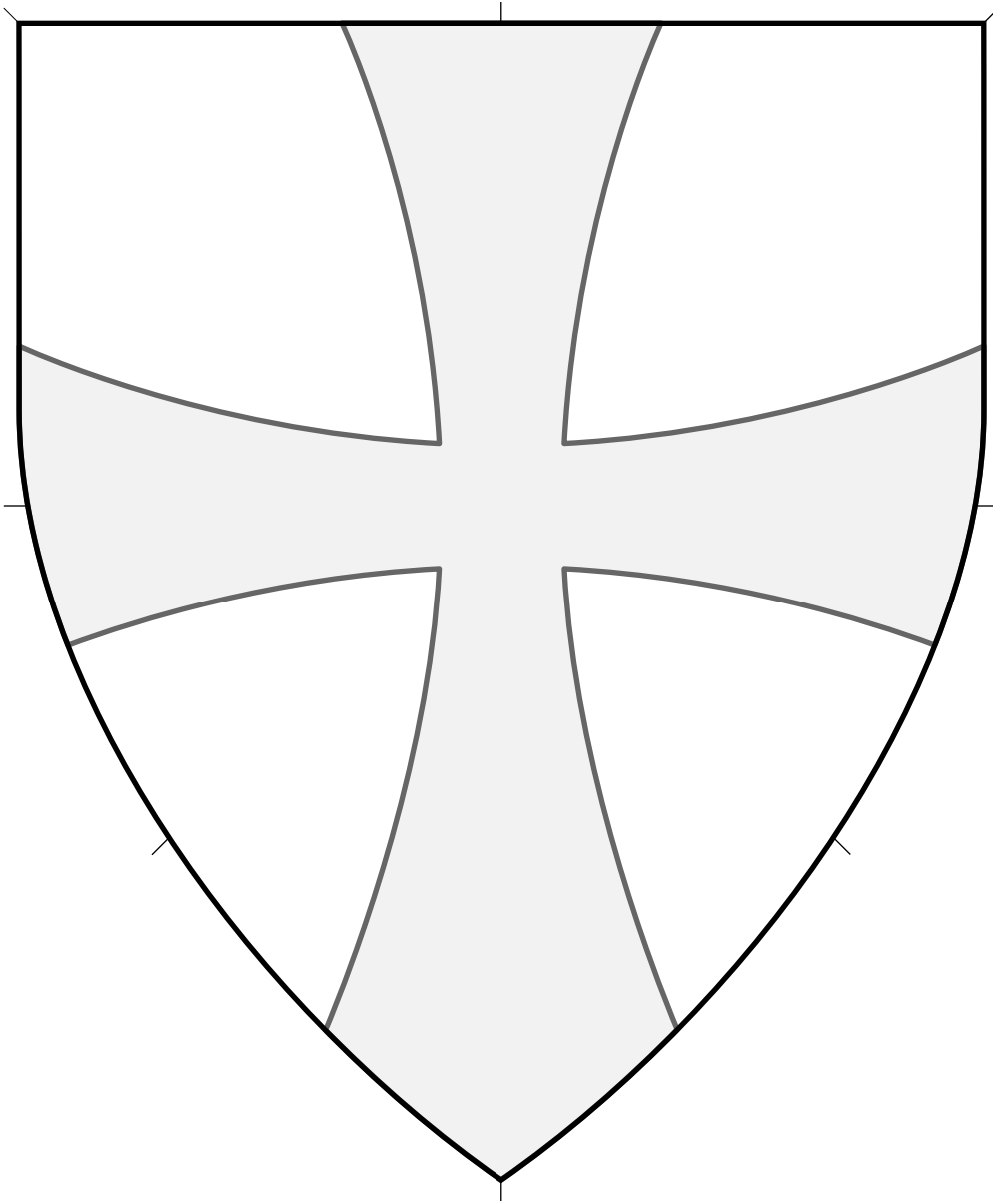

Central ordinary.

Cross Formy Throughout (1) 4.363

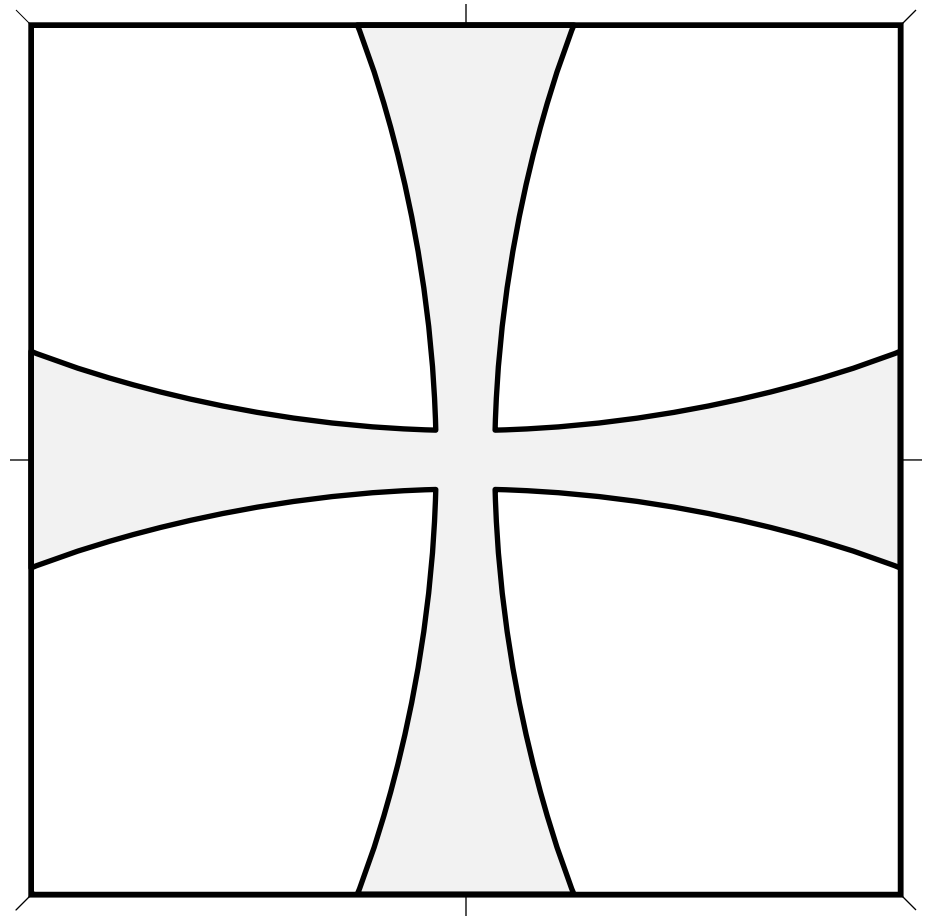
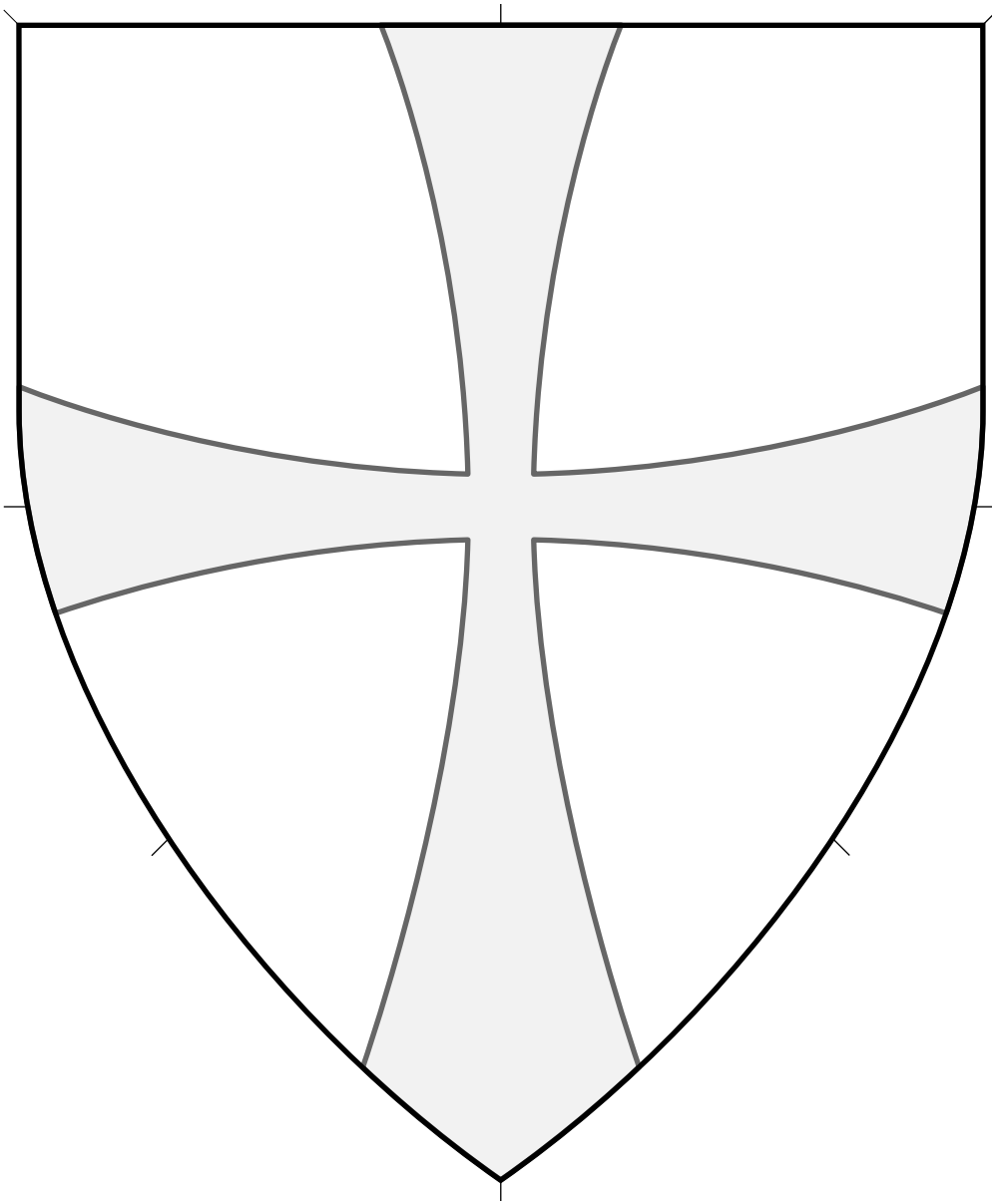

Central ordinary.

Cross Formy Throughout (2) 4.364

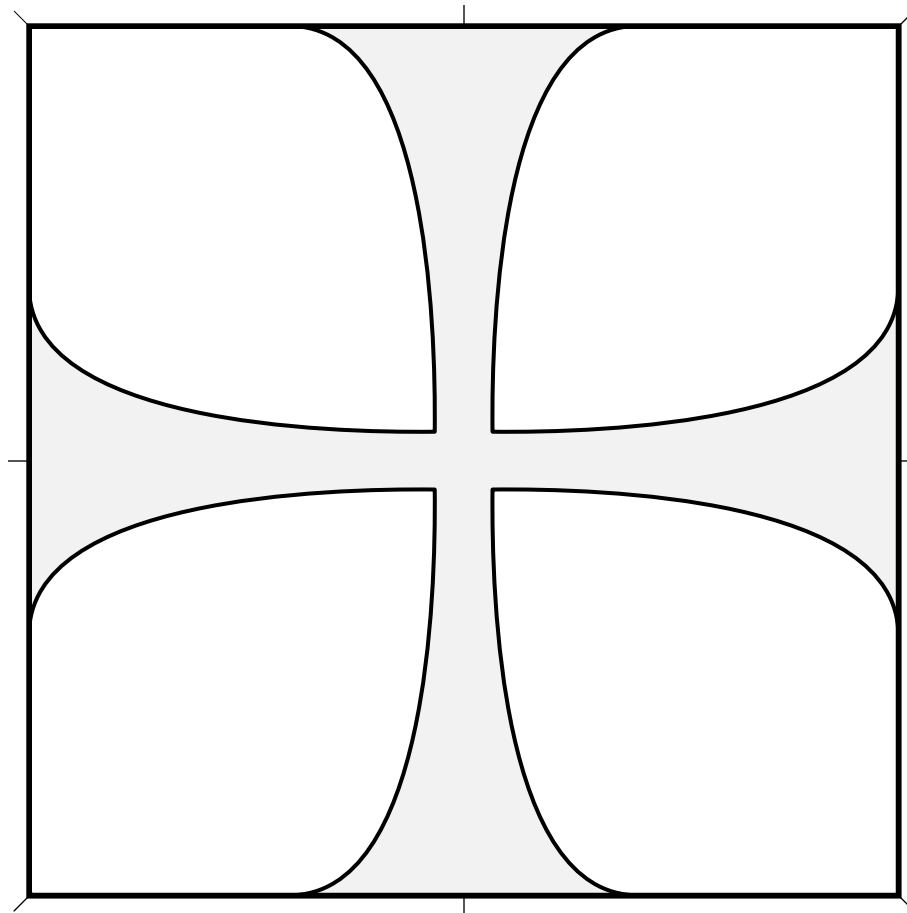
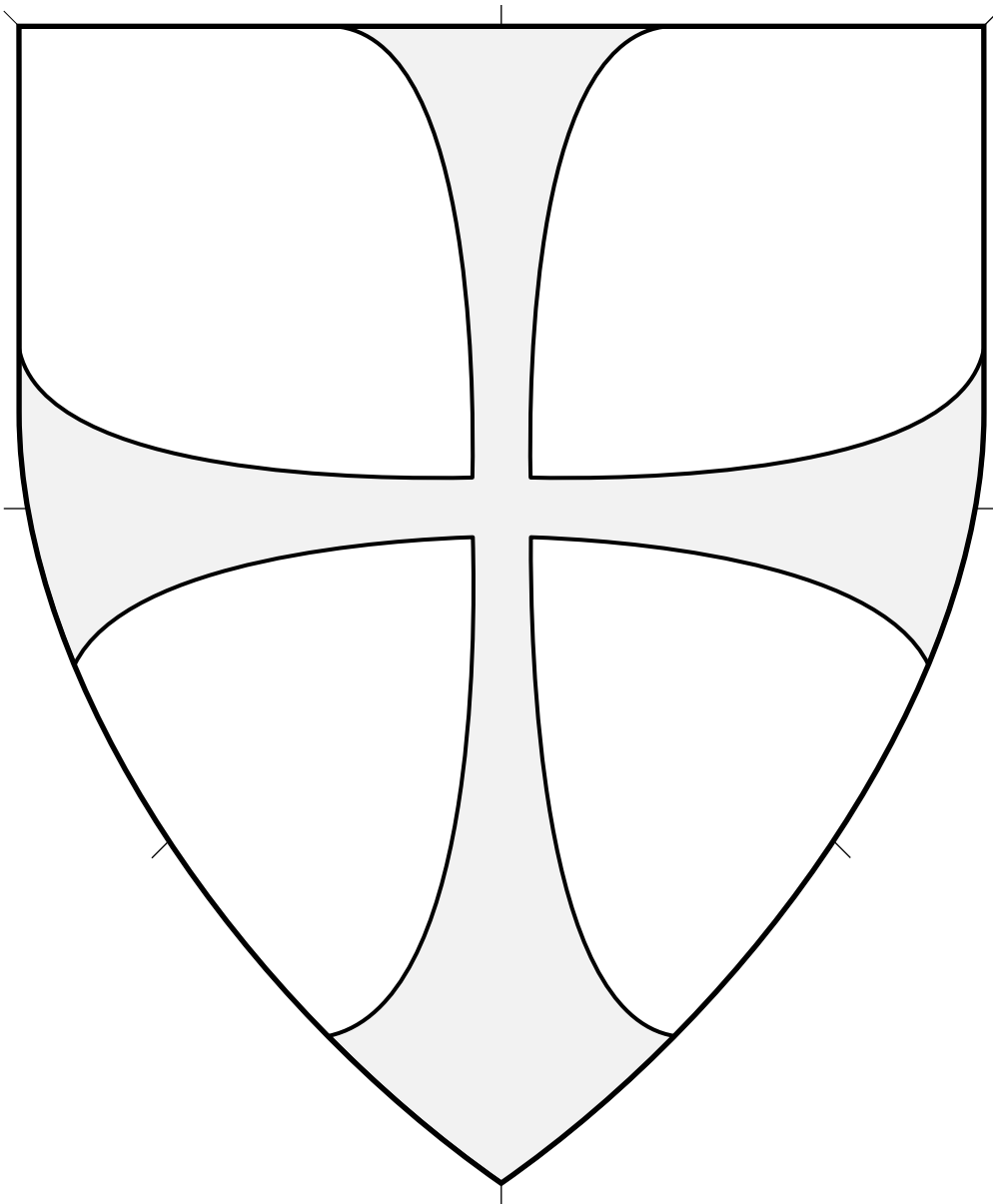

Central ordinary.

Source: KBR MS II 6616. (Folio 36r.) Artist unknown.
(Arms of Antoon Ruebs.)

Cross Formy Throughout (3) 4.365

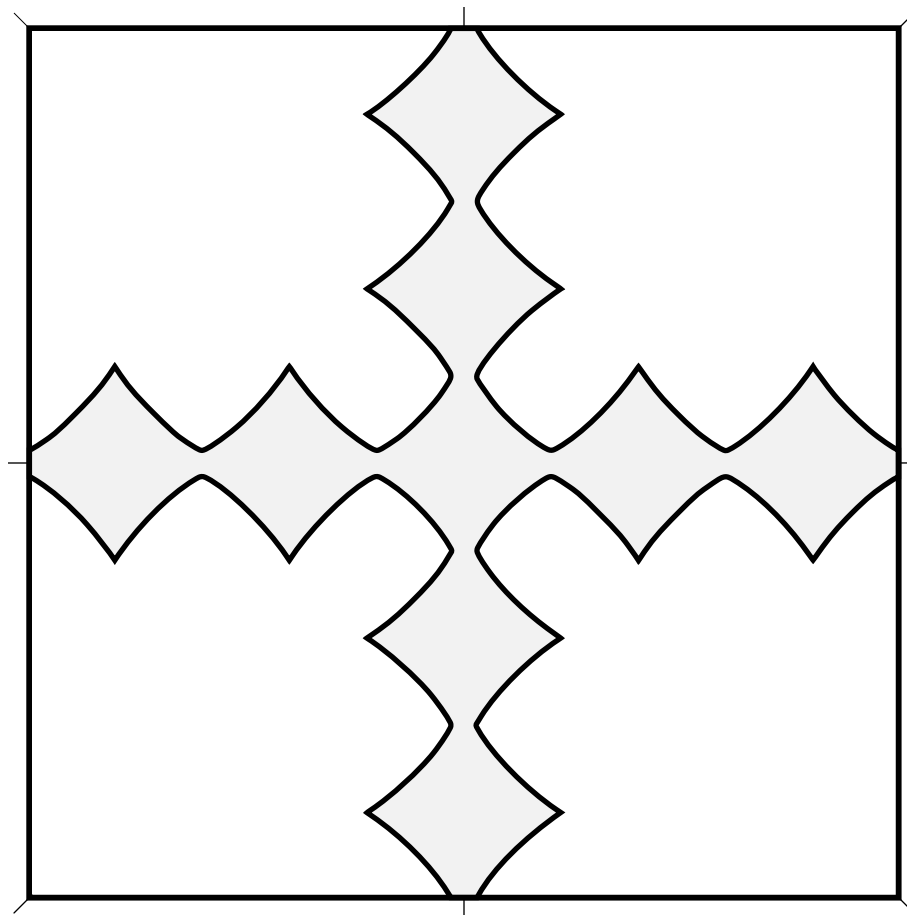
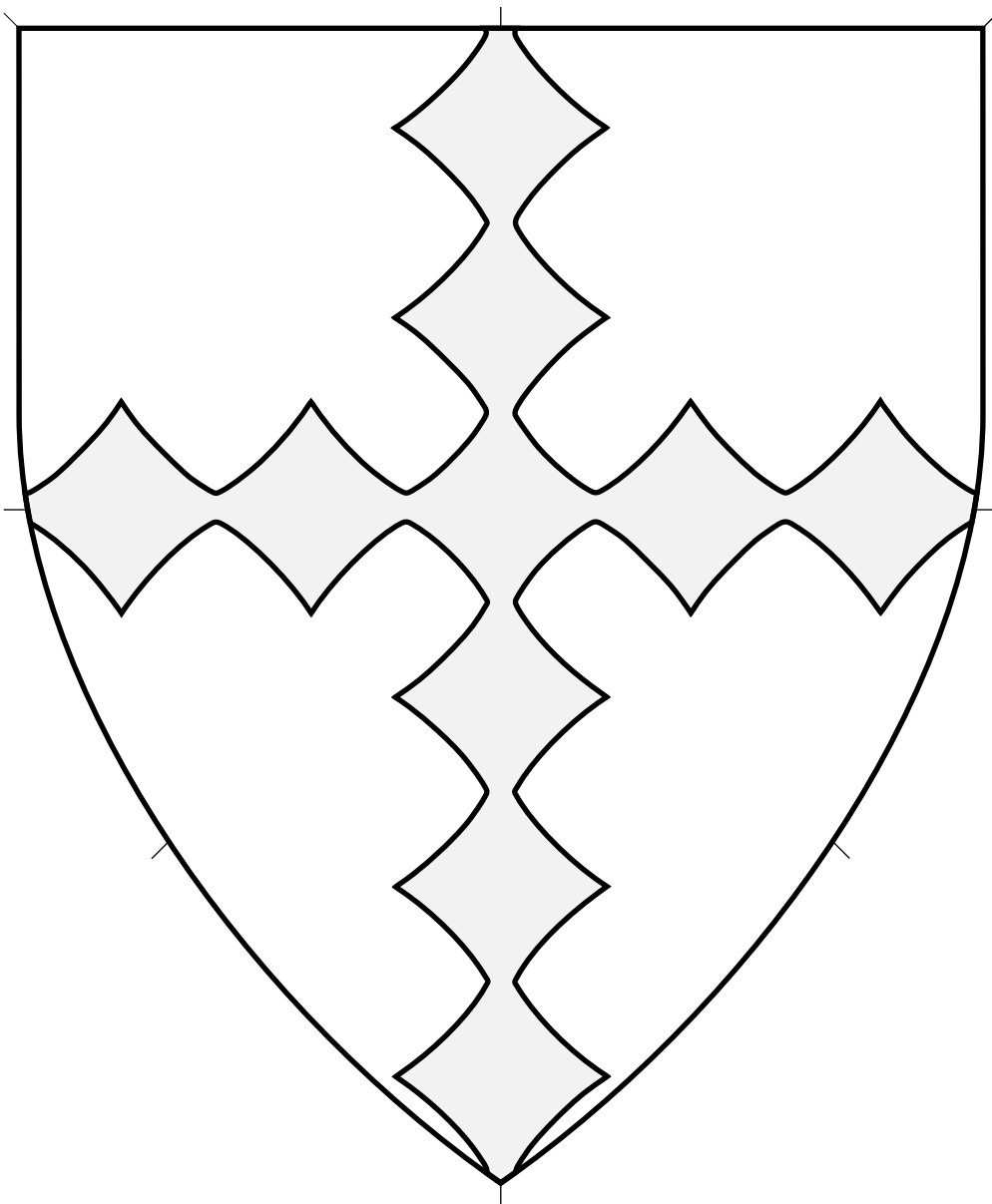

Central ordinary.

Source: Armorial de Gelre. Artist: Claes Heinenzoon. (Page 221.)
Adapted by Mathghamhain Ua Ruadháin.

Cross Fusilly 4.366

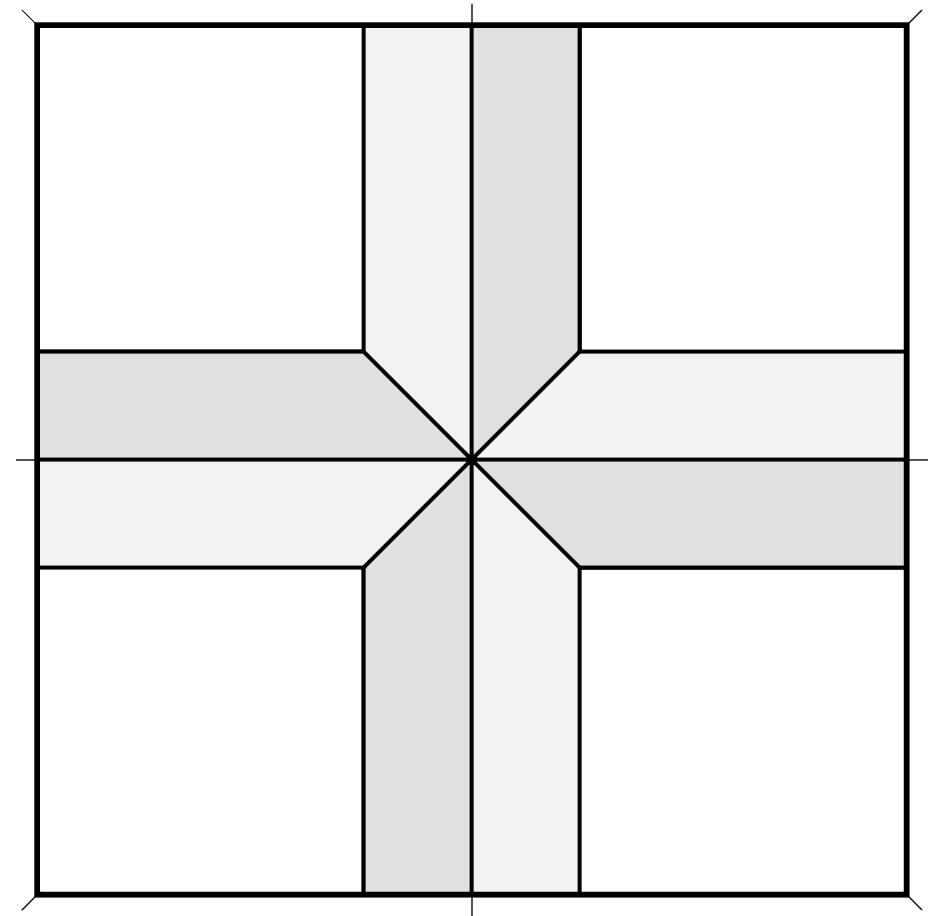
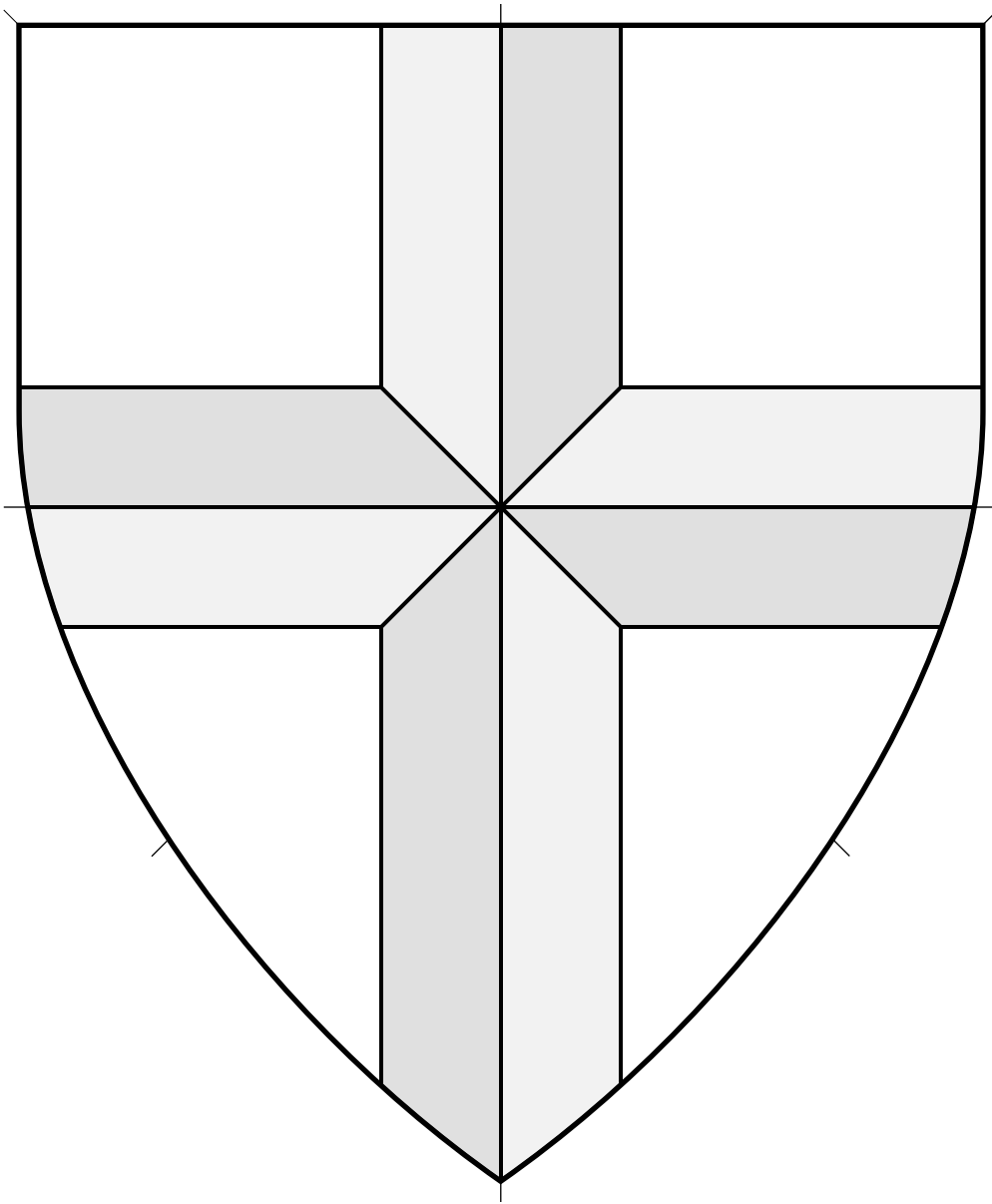

Central ordinary.

Source: BnF MS Allemand 304. Artist unknown. (Page 610.)

Cross Gyronny 4.367

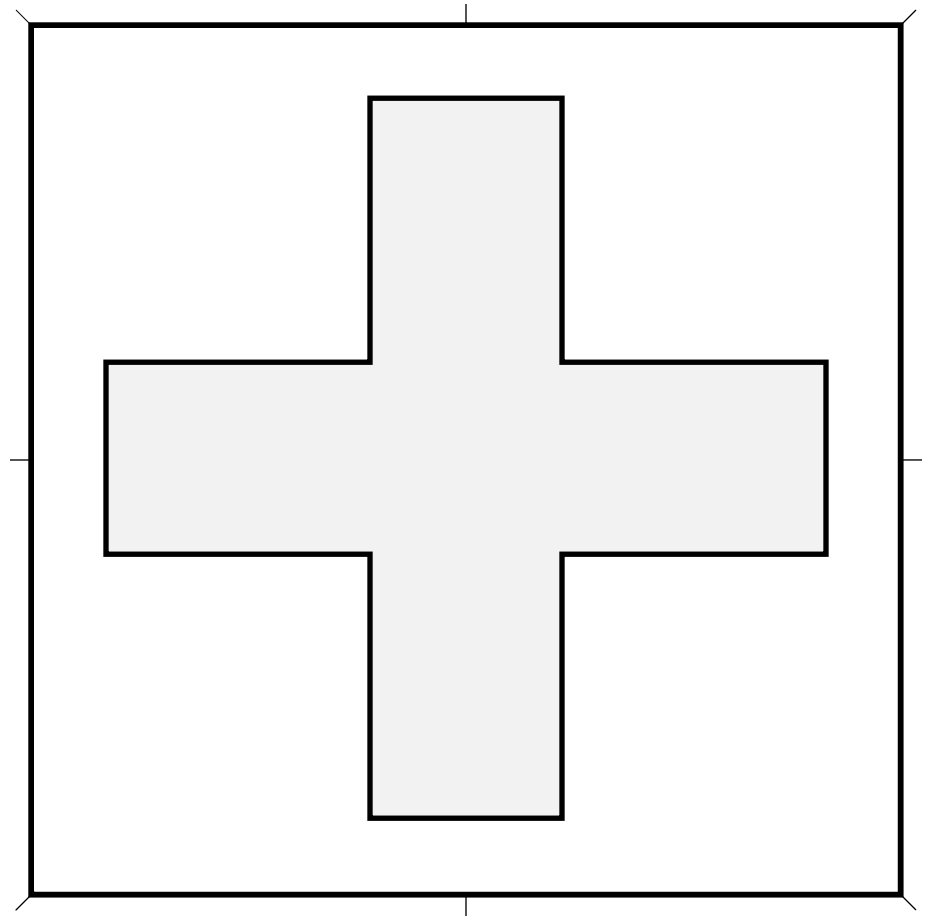
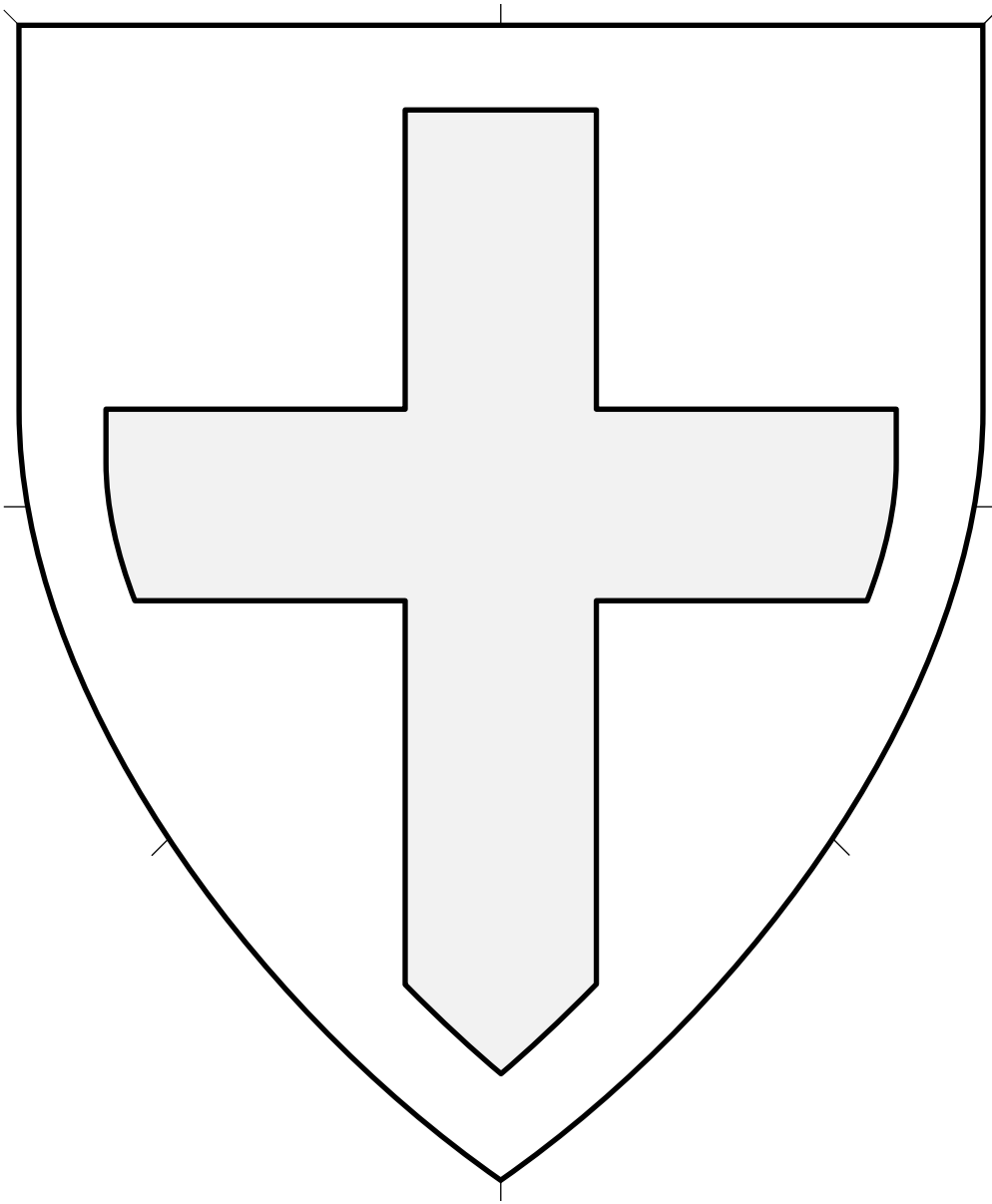

Central ordinary. A cross couped parallel to the border of the device.

Cross Humetty • 4.368

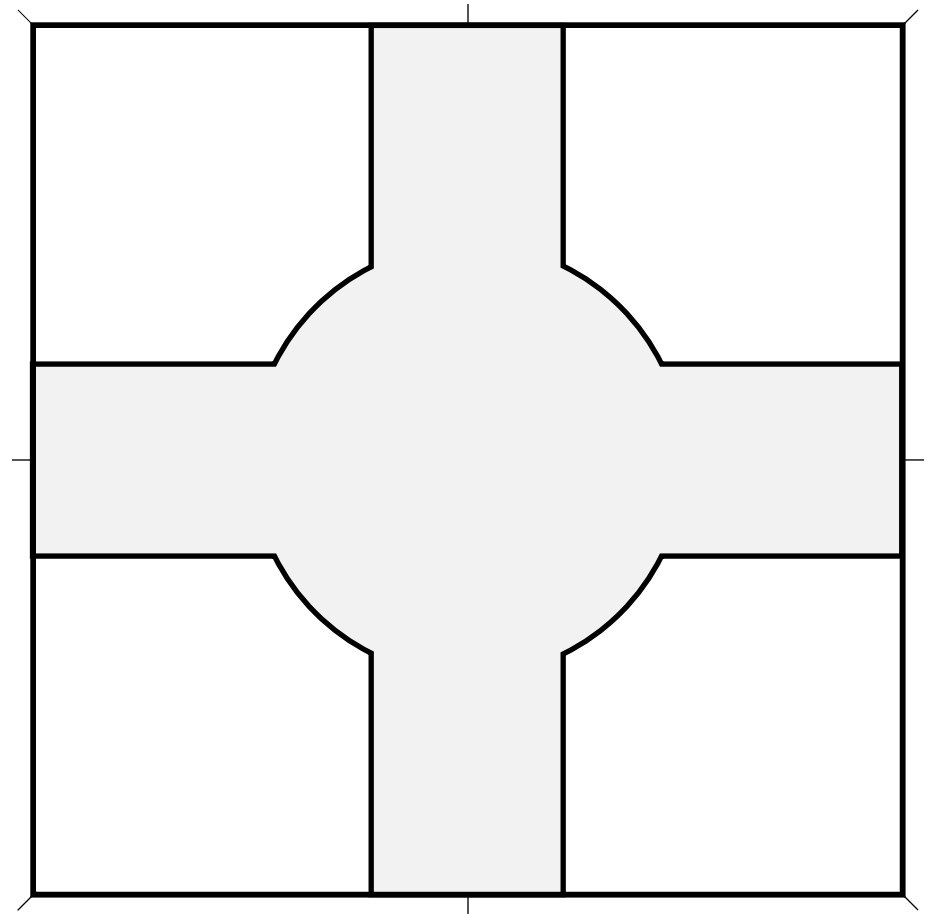
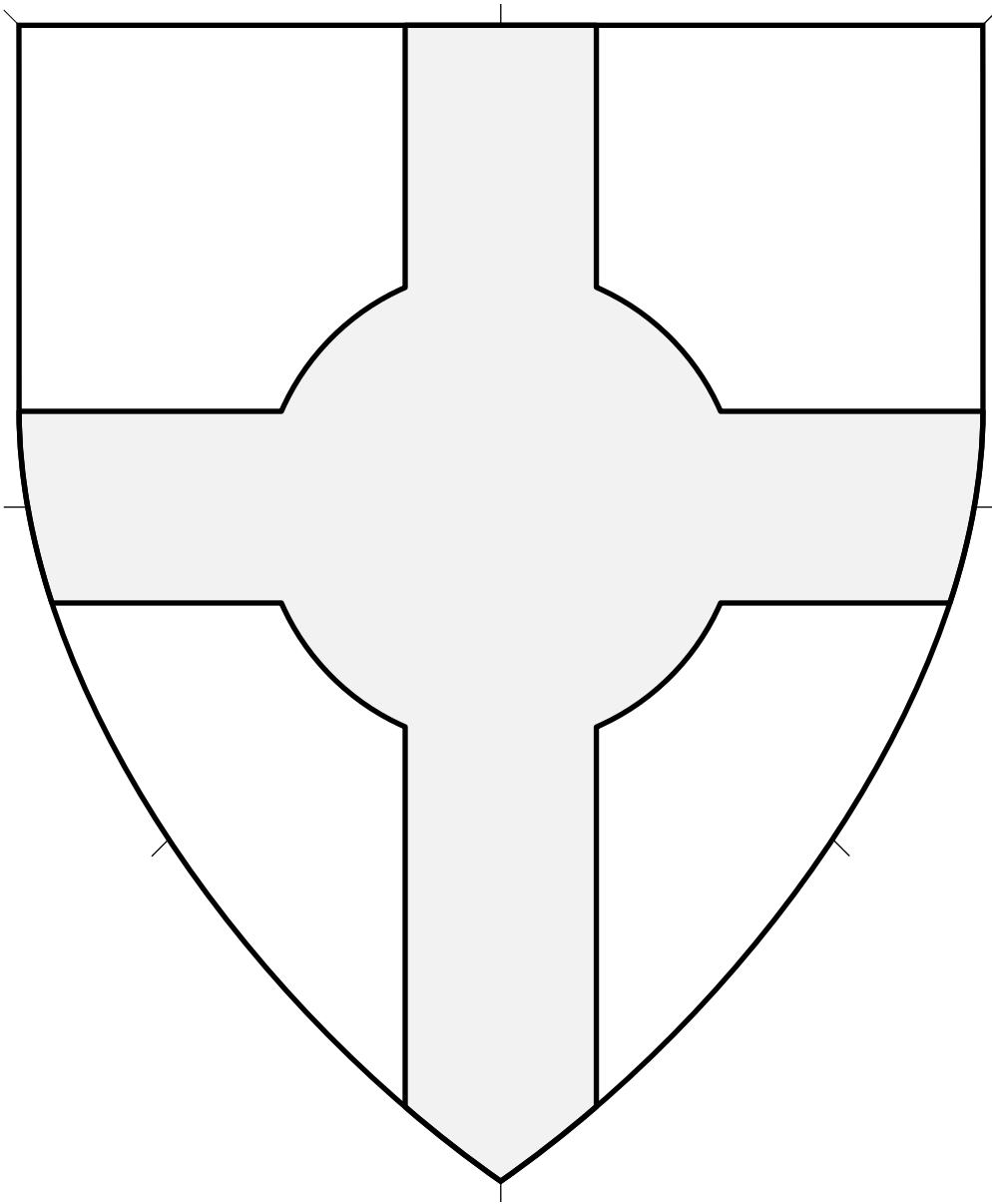

Central ordinary. A cross with a circular protrusion in the center. Considered a step from core practice (SFCP).

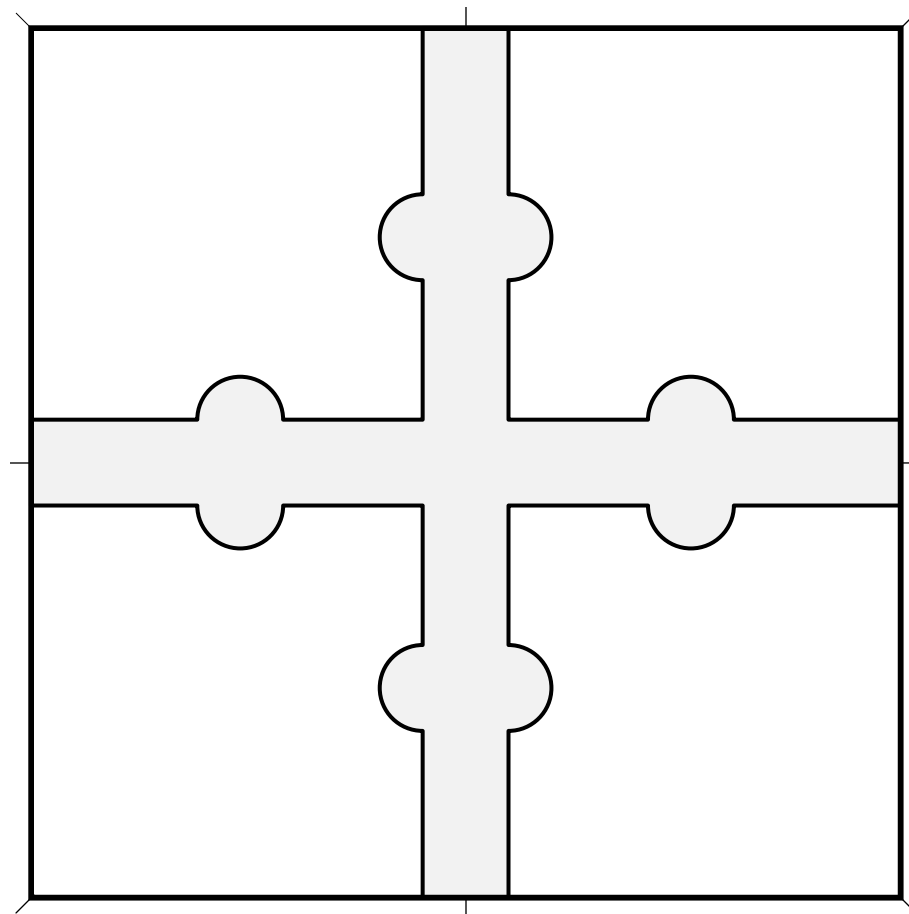
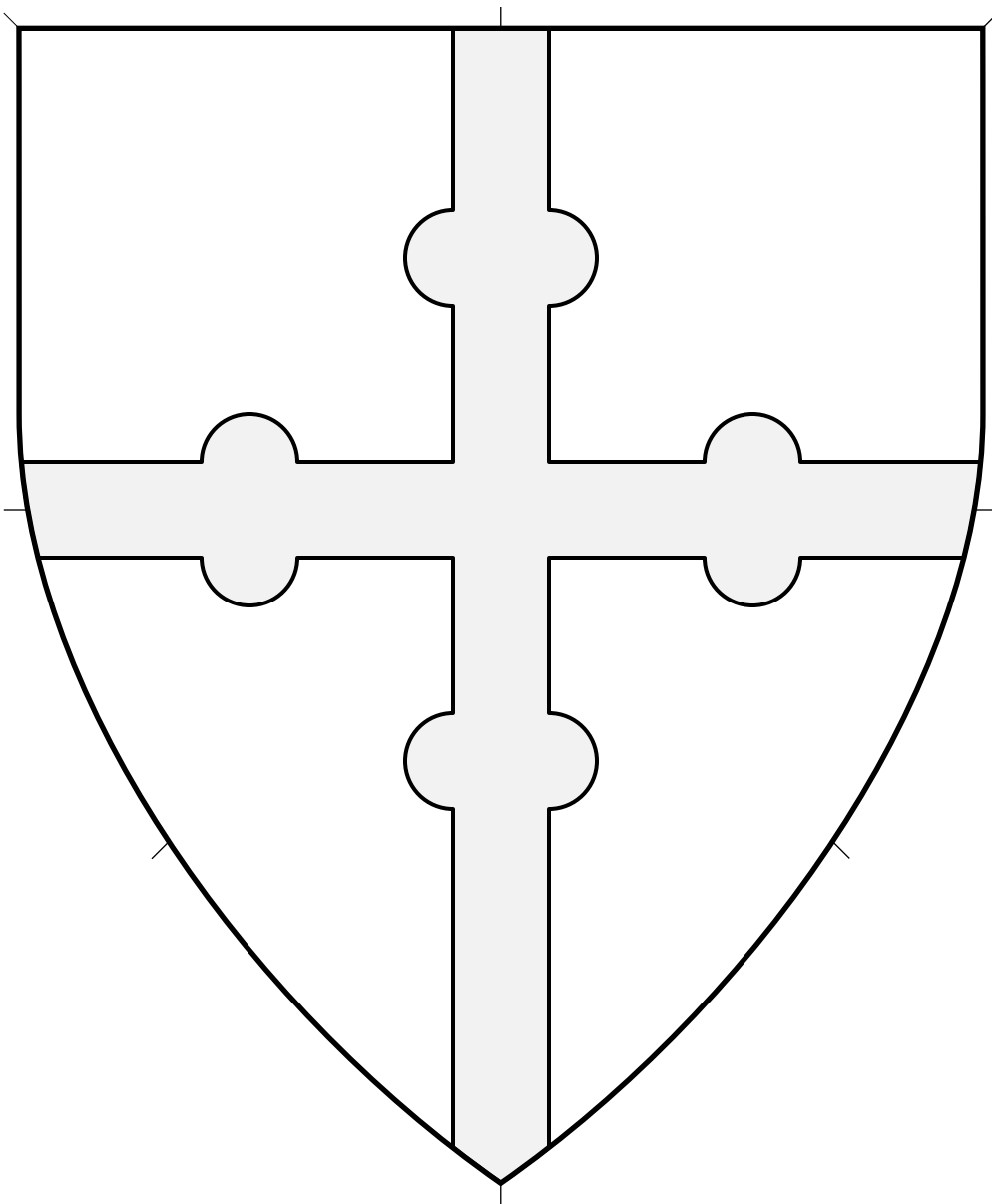

Central ordinary.

Source: The Accedence of Armorie. (Folio 74r.) Artist unknown.

Cross Nowyed 4.370

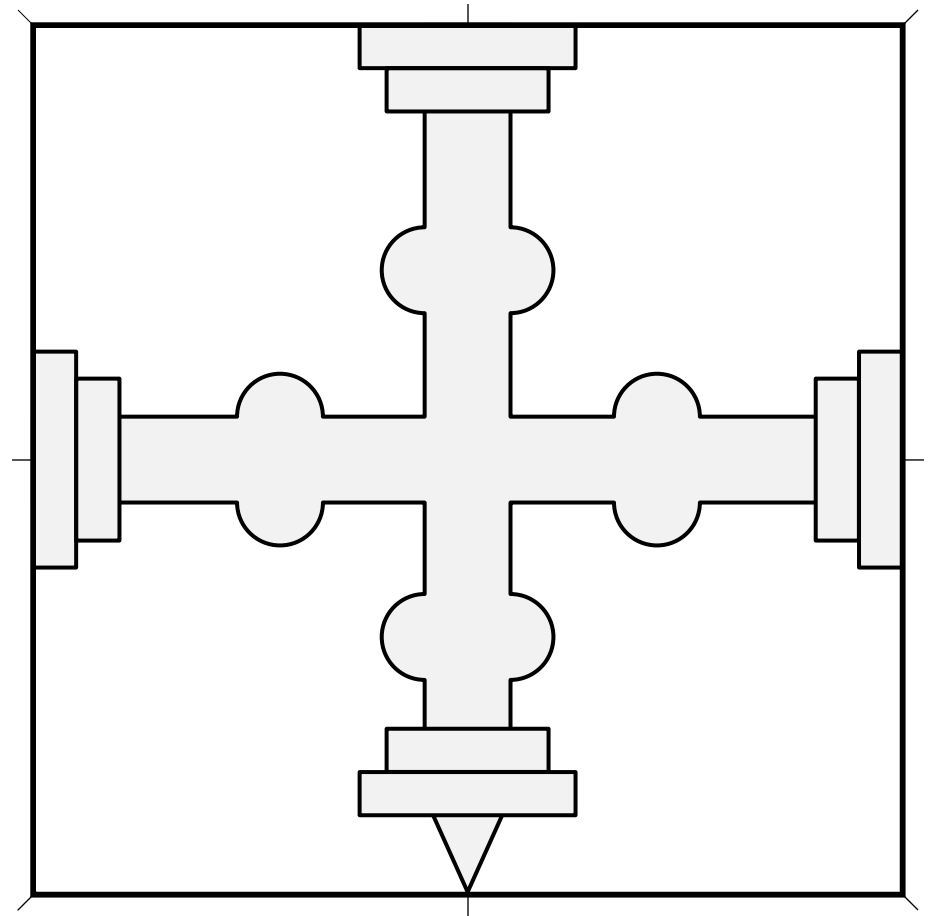
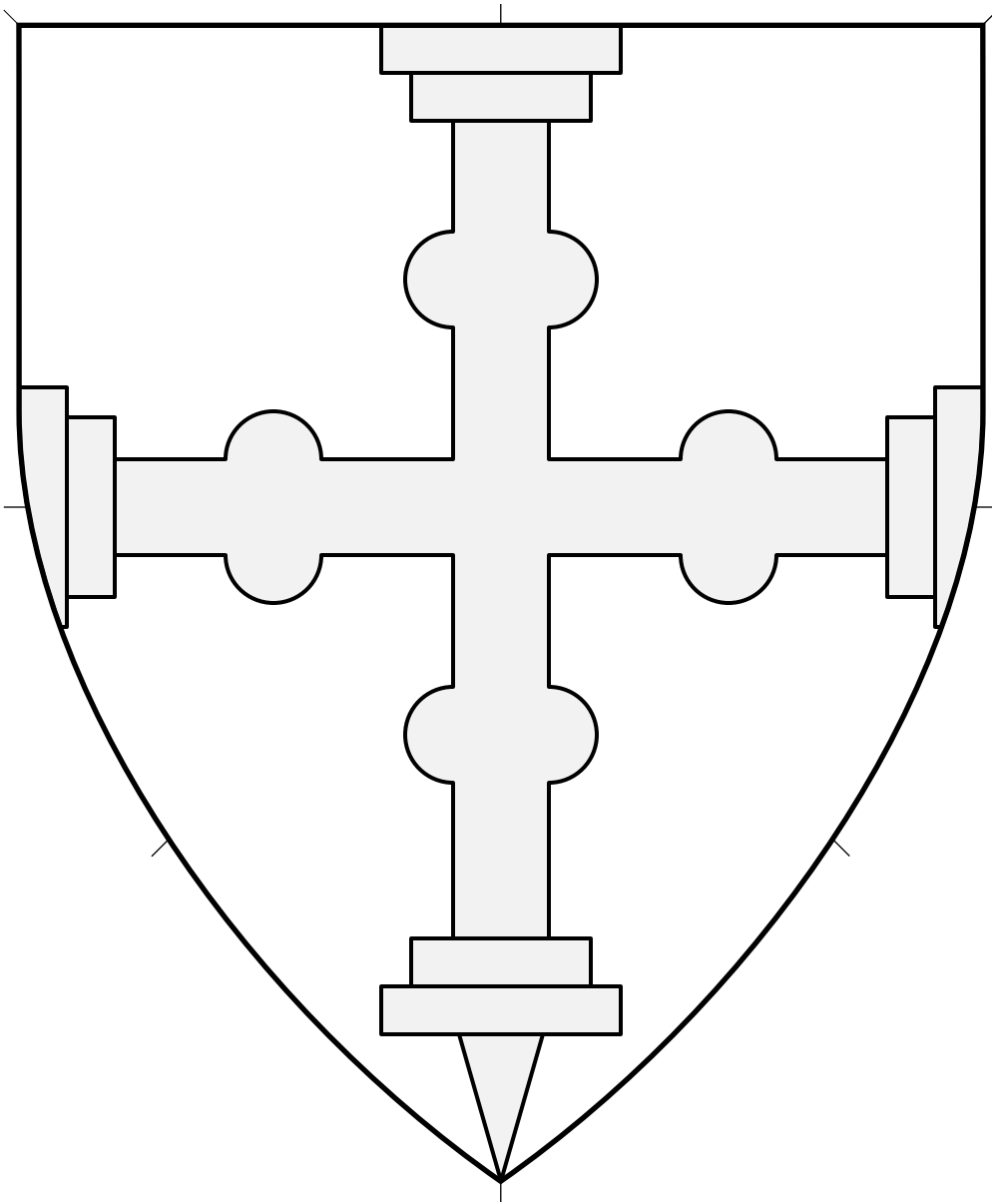

Central ordinary.

Source: The Accedence of Armorie. (Folio 74r.)
Artist unknown.

Cross Nowyed Degraded Fitchy 4.371

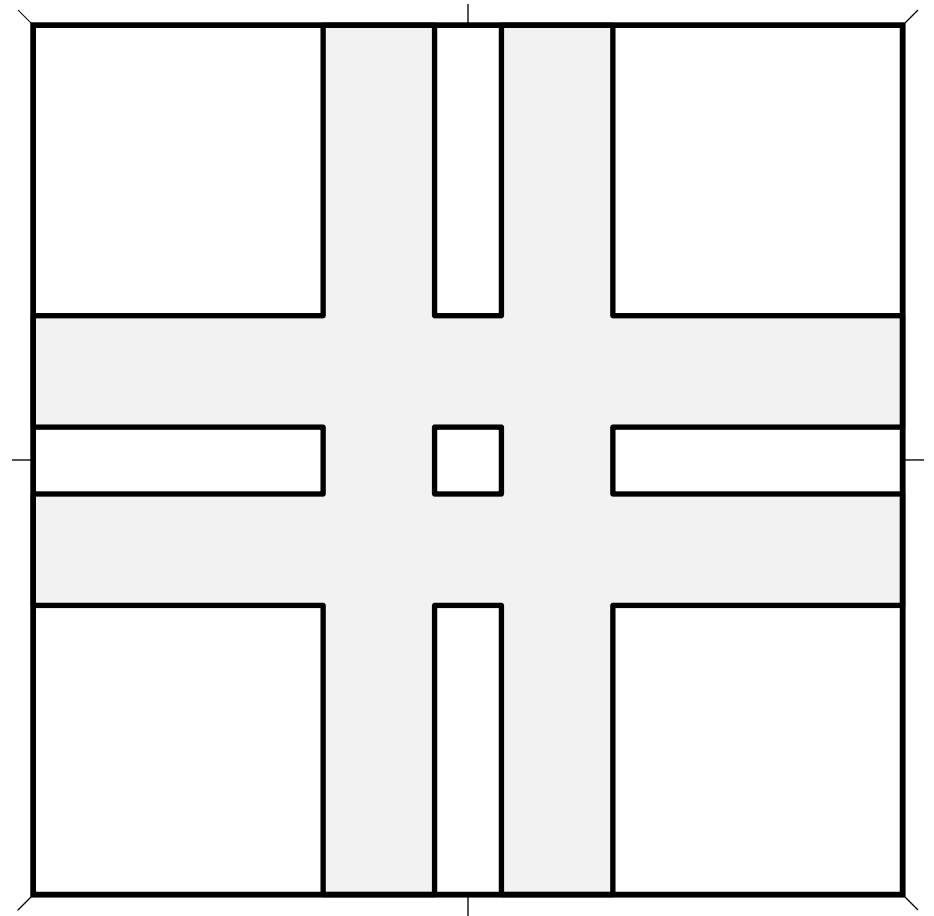
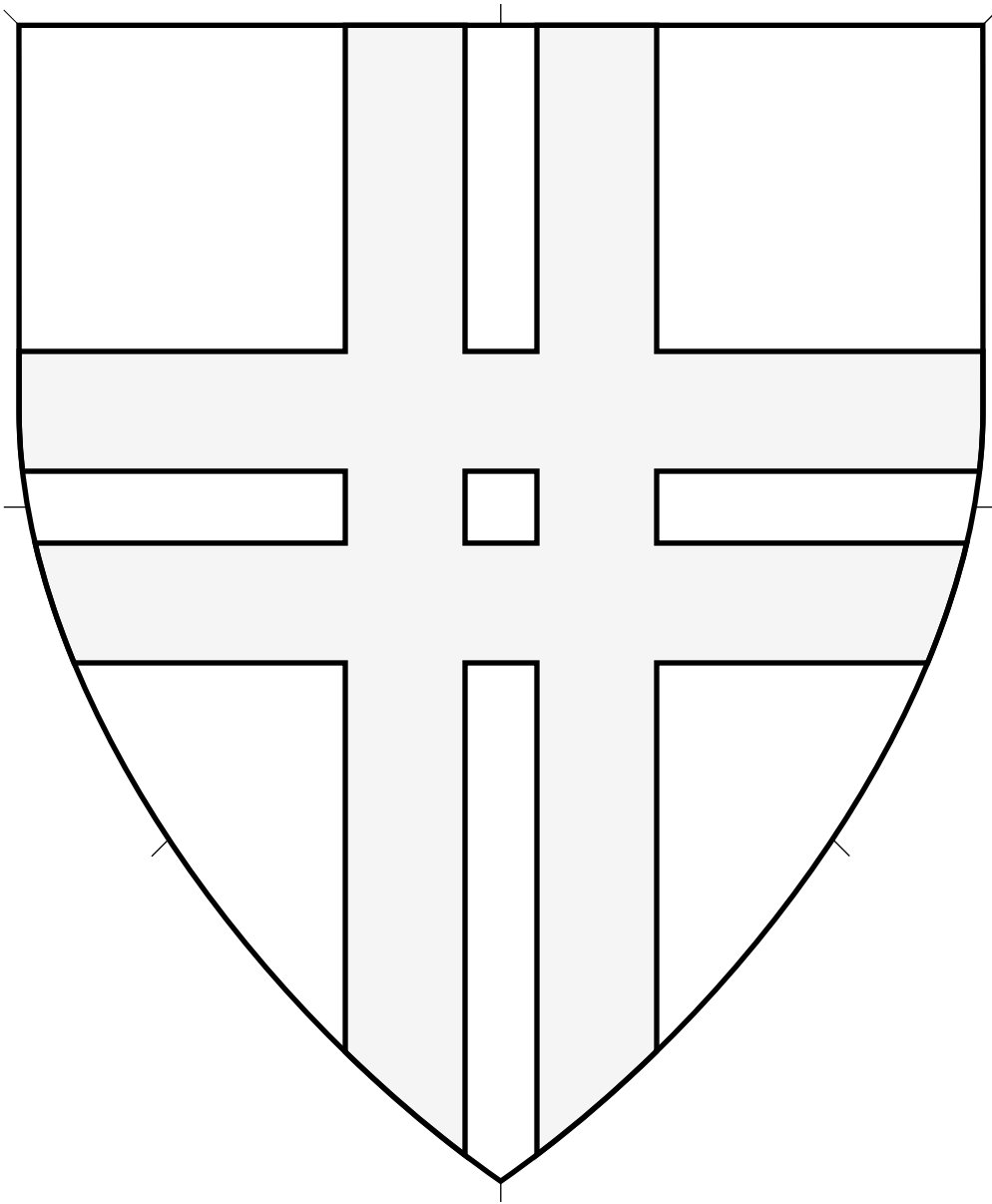

Central ordinary. A cross which has been split.

Cross Parted 4.372

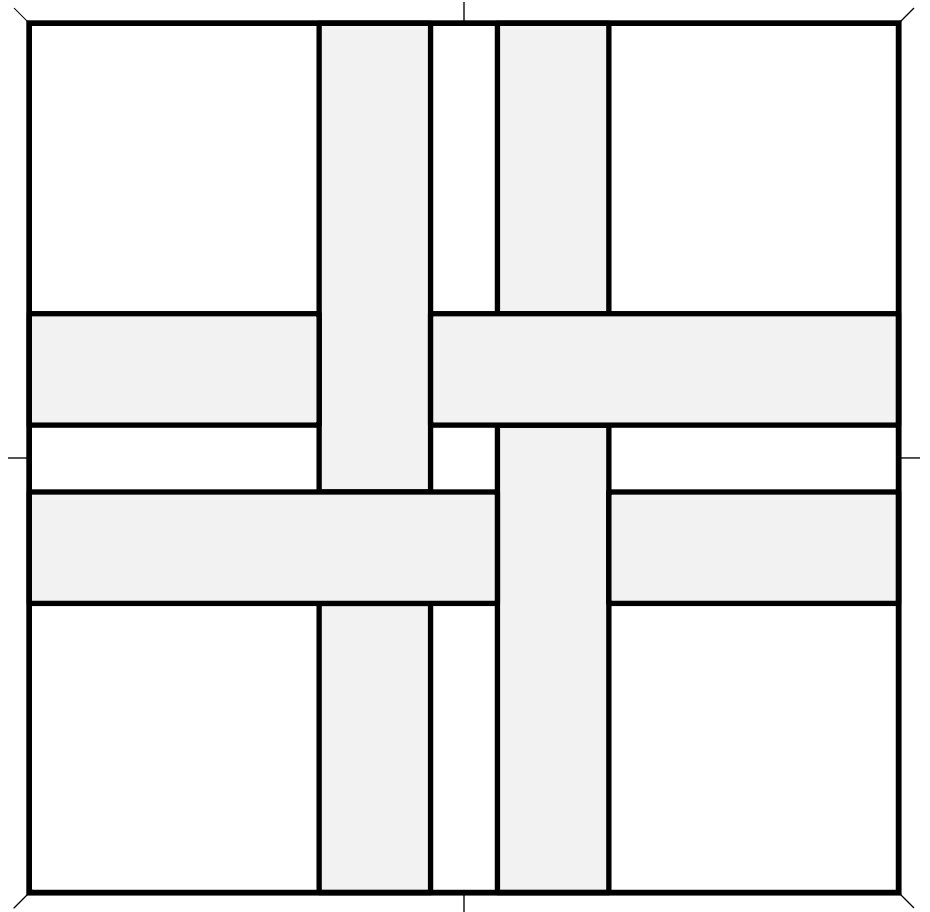
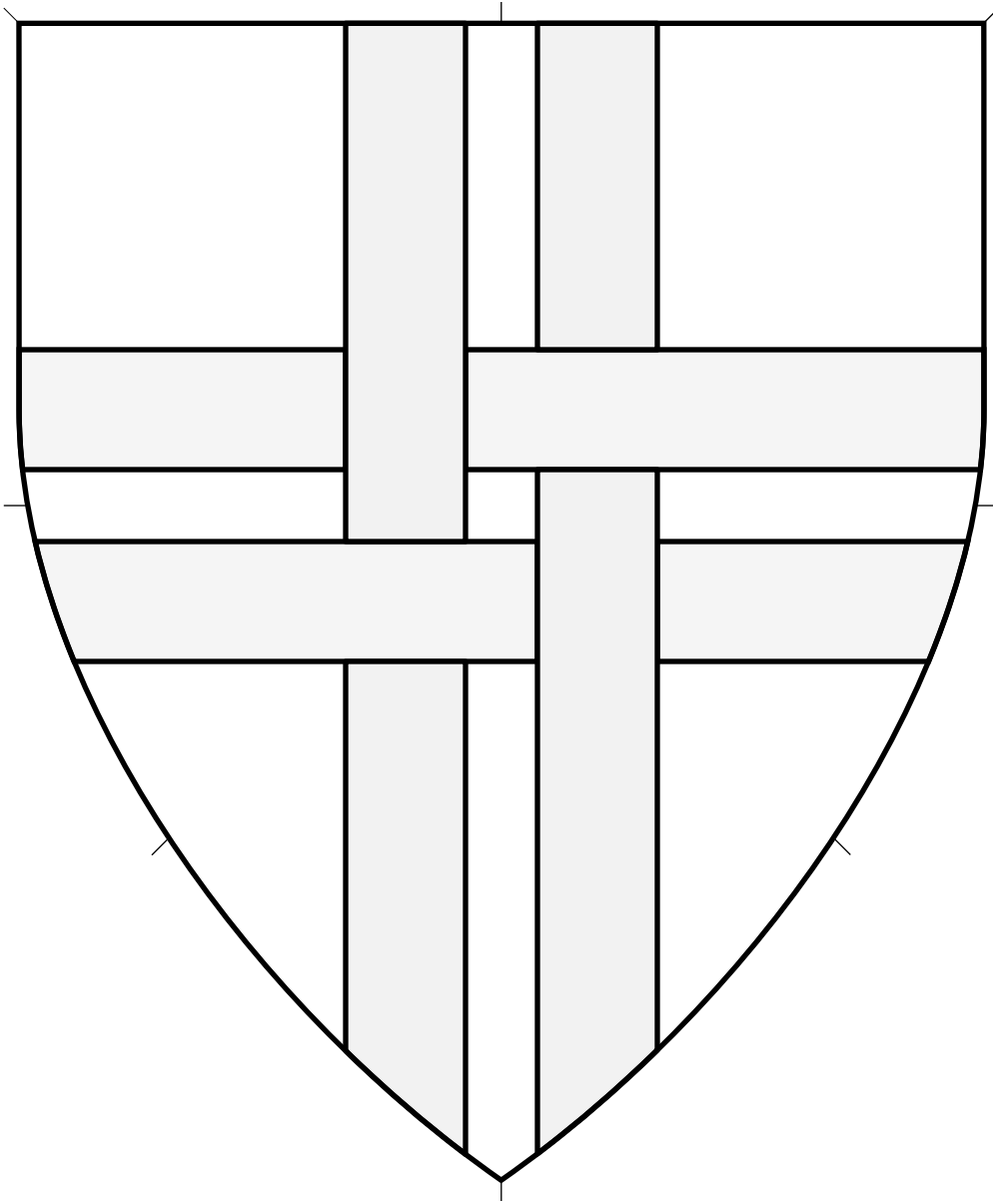

Central ordinary.
A cross which has been split into interlaced strips.

Cross Parted and Fretted 4.373

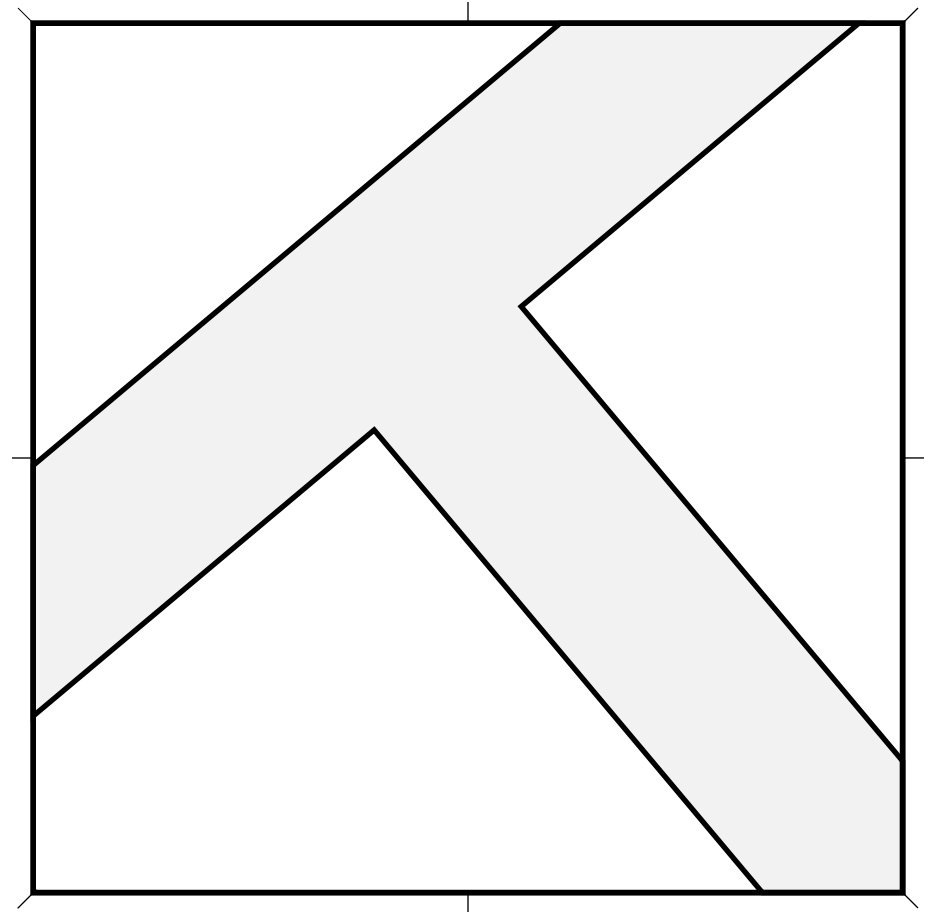
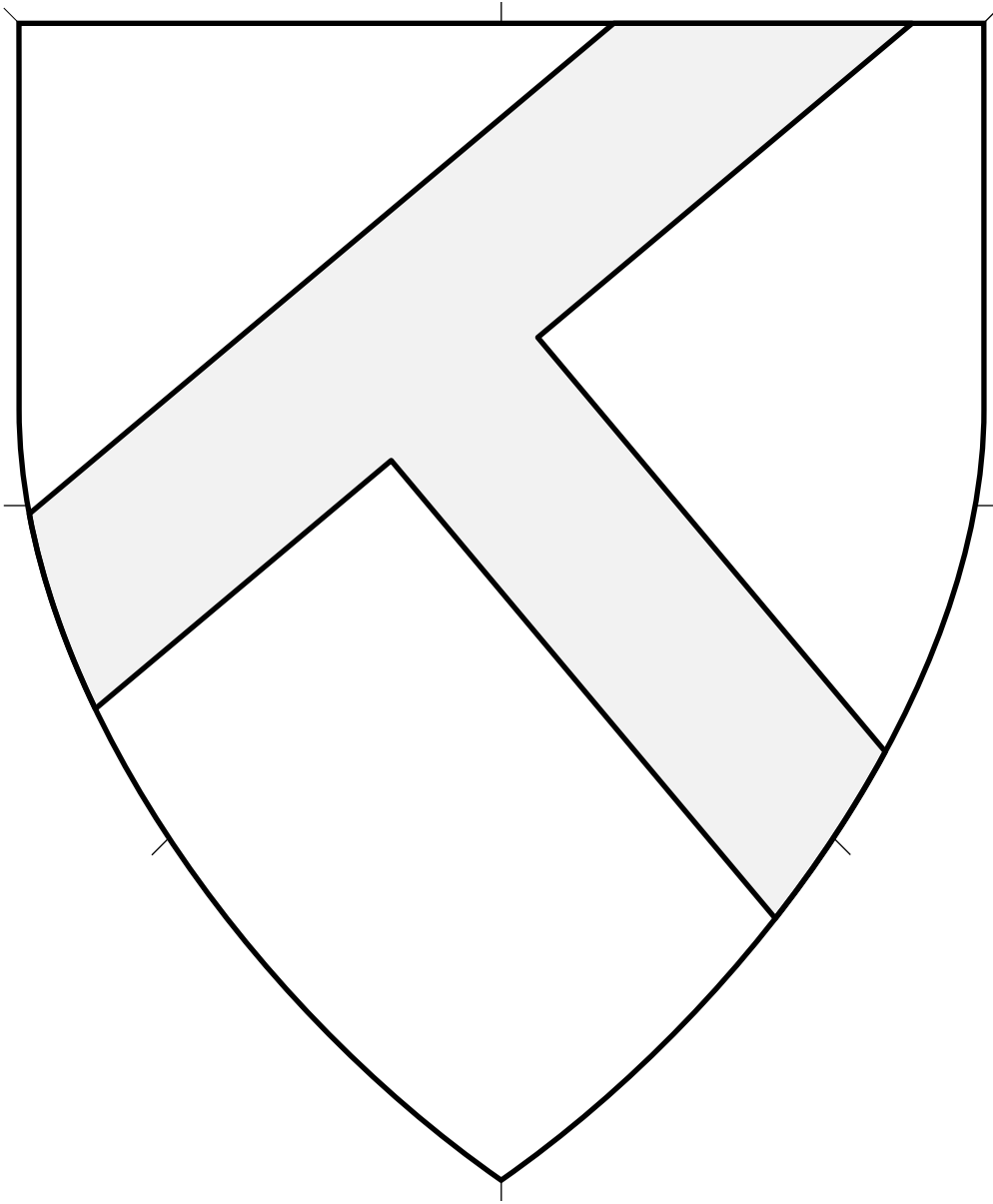

Central ordinary.
If it leans in the other direction, blazoned “a cross portate reversed.”

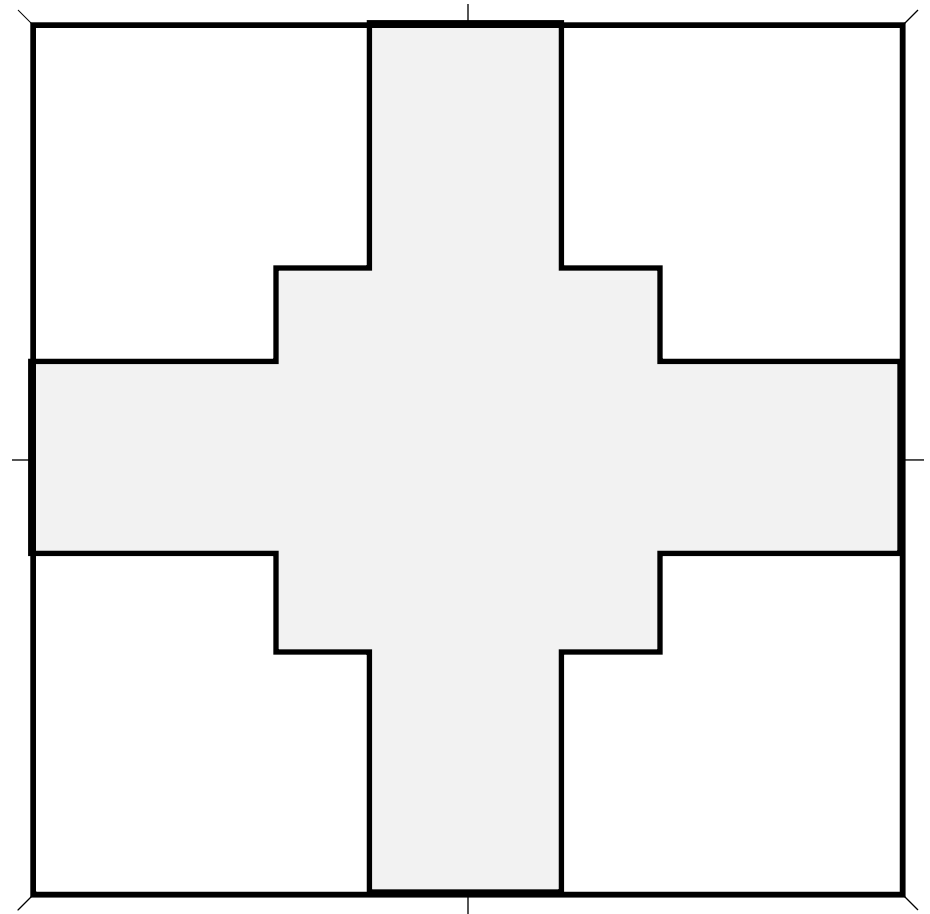
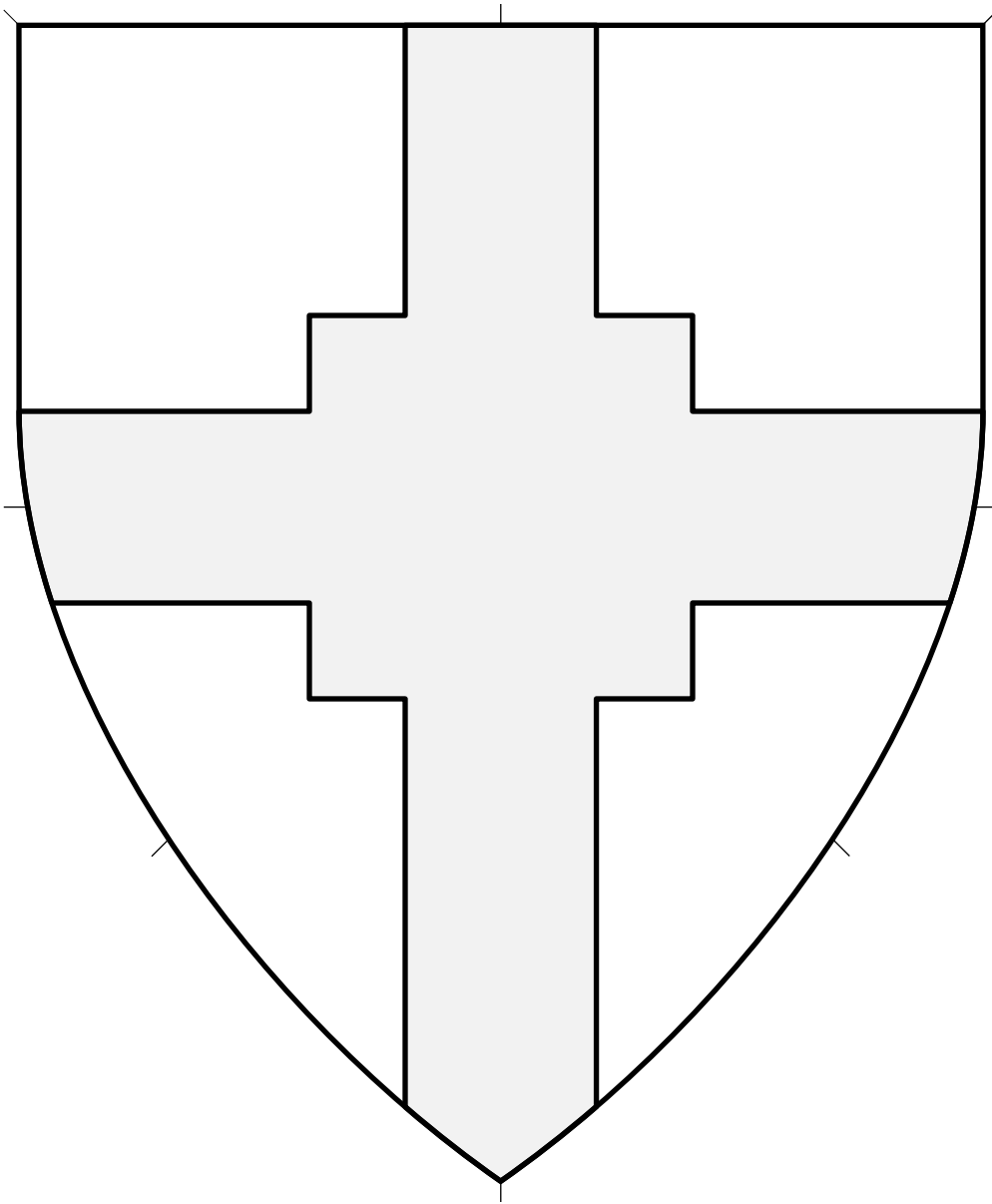

Central ordinary. A cross with a square protrusion in the center. Considered a step from core practice (SFCP).

Cross Quadrate 4.375

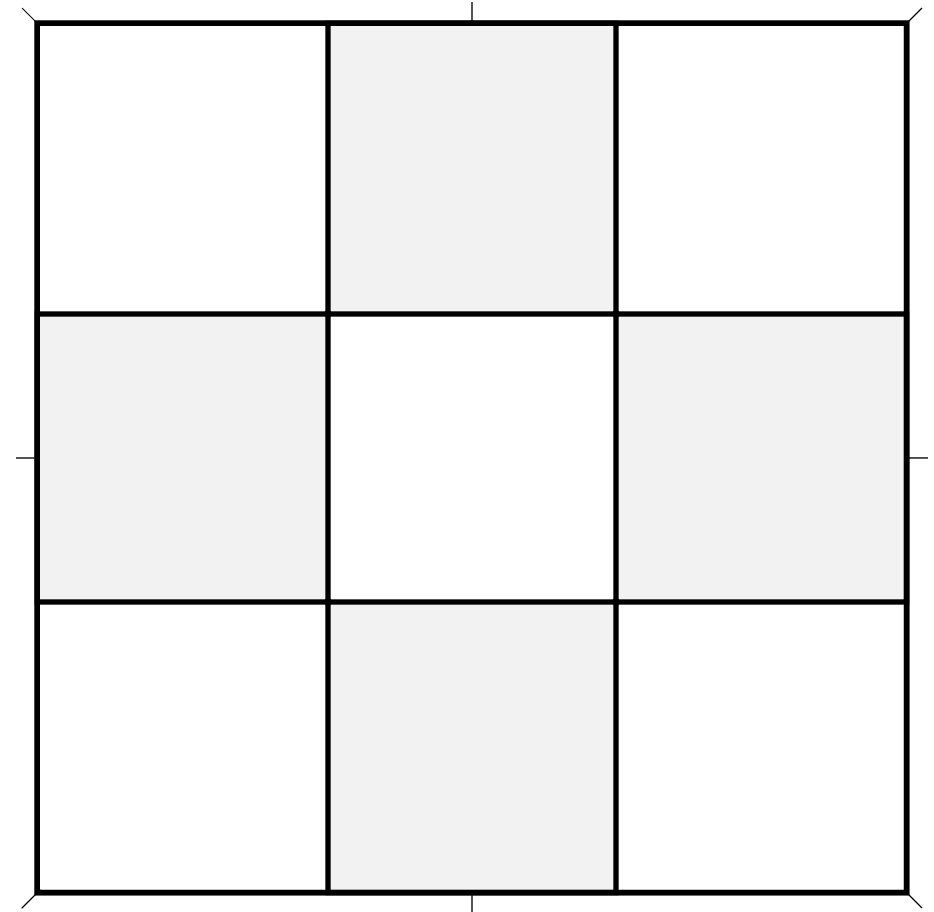
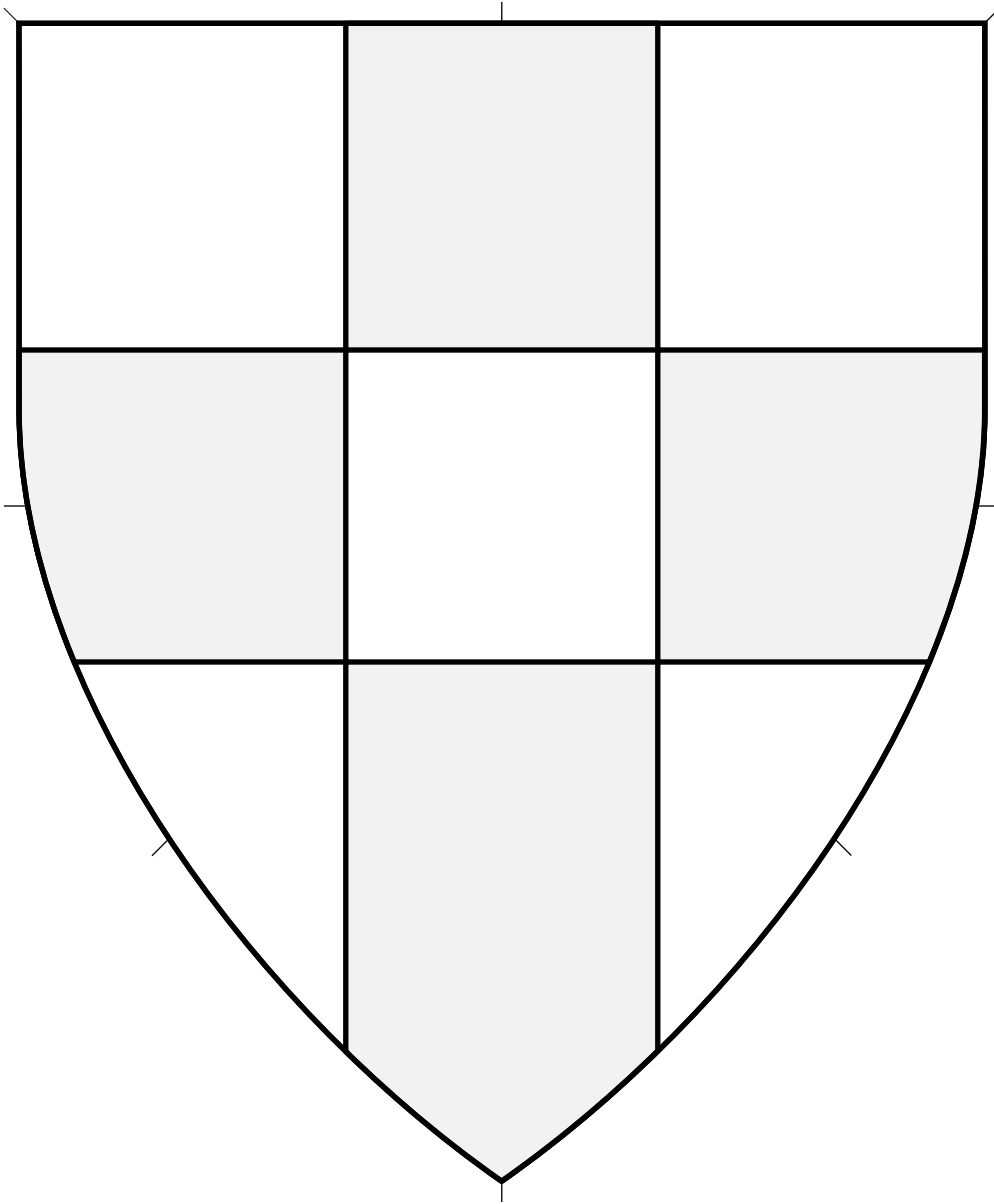

Central ordinary. A cross with its center removed.

In period this might be considered a field division blazoned “party of nine,” but in SCA usage this is viewed as an ordinary with a hole in its center, and thus considered a charge.

Cross Quarter-Pierced (1) 4.376

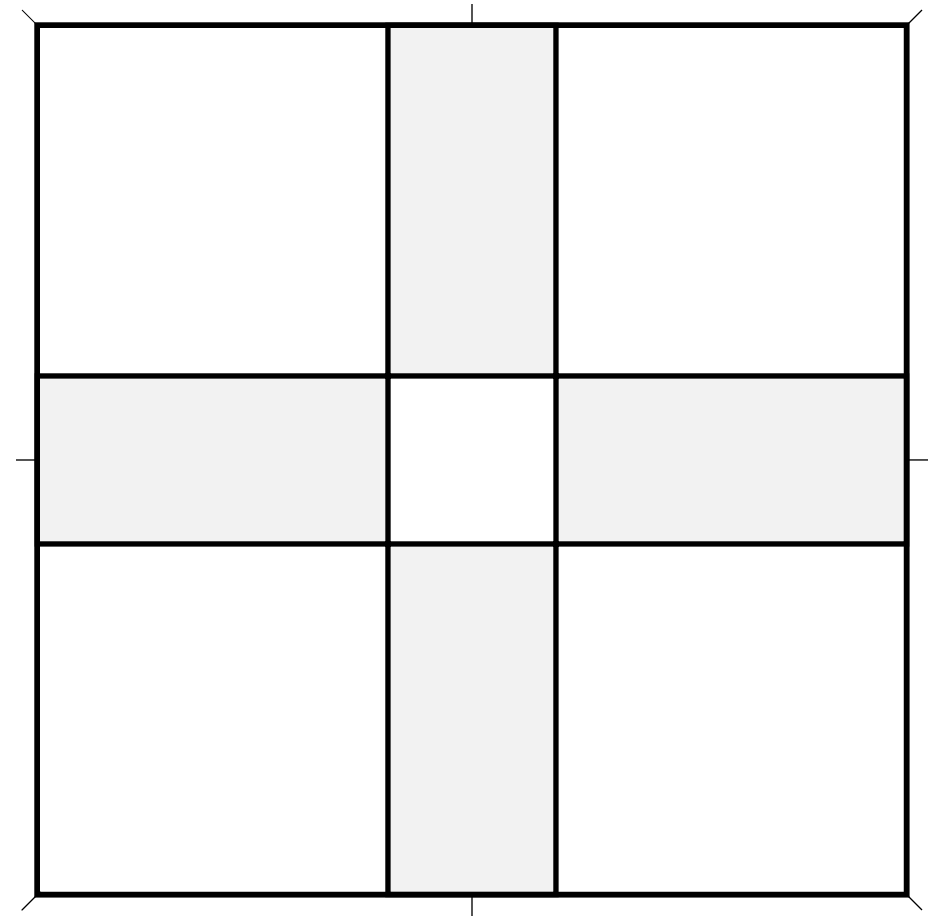
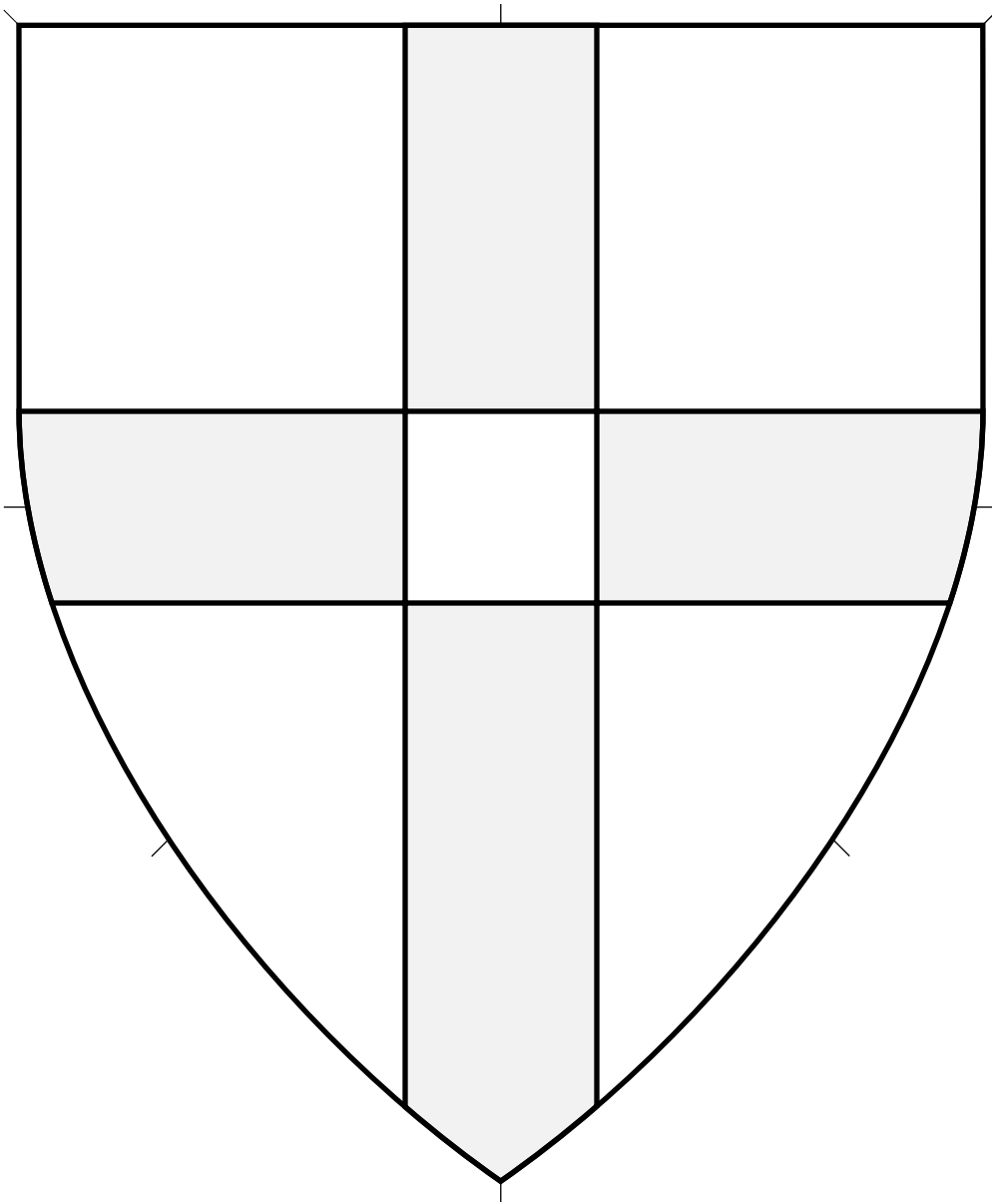

Central ordinary. A cross with its center removed.

Source: Wappenbuch der Arlberg-Bruderschaft.
Artist: Vigil Raber. (Page 197.)

Cross Quarter-Pierced (2) 4.377

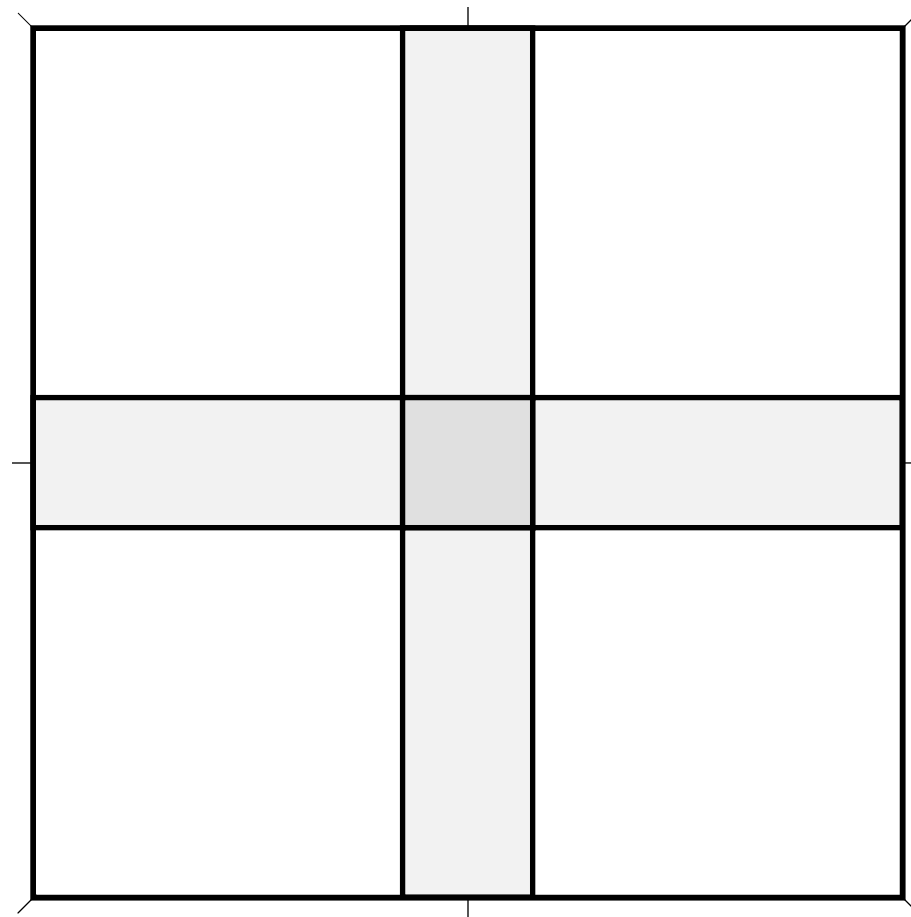
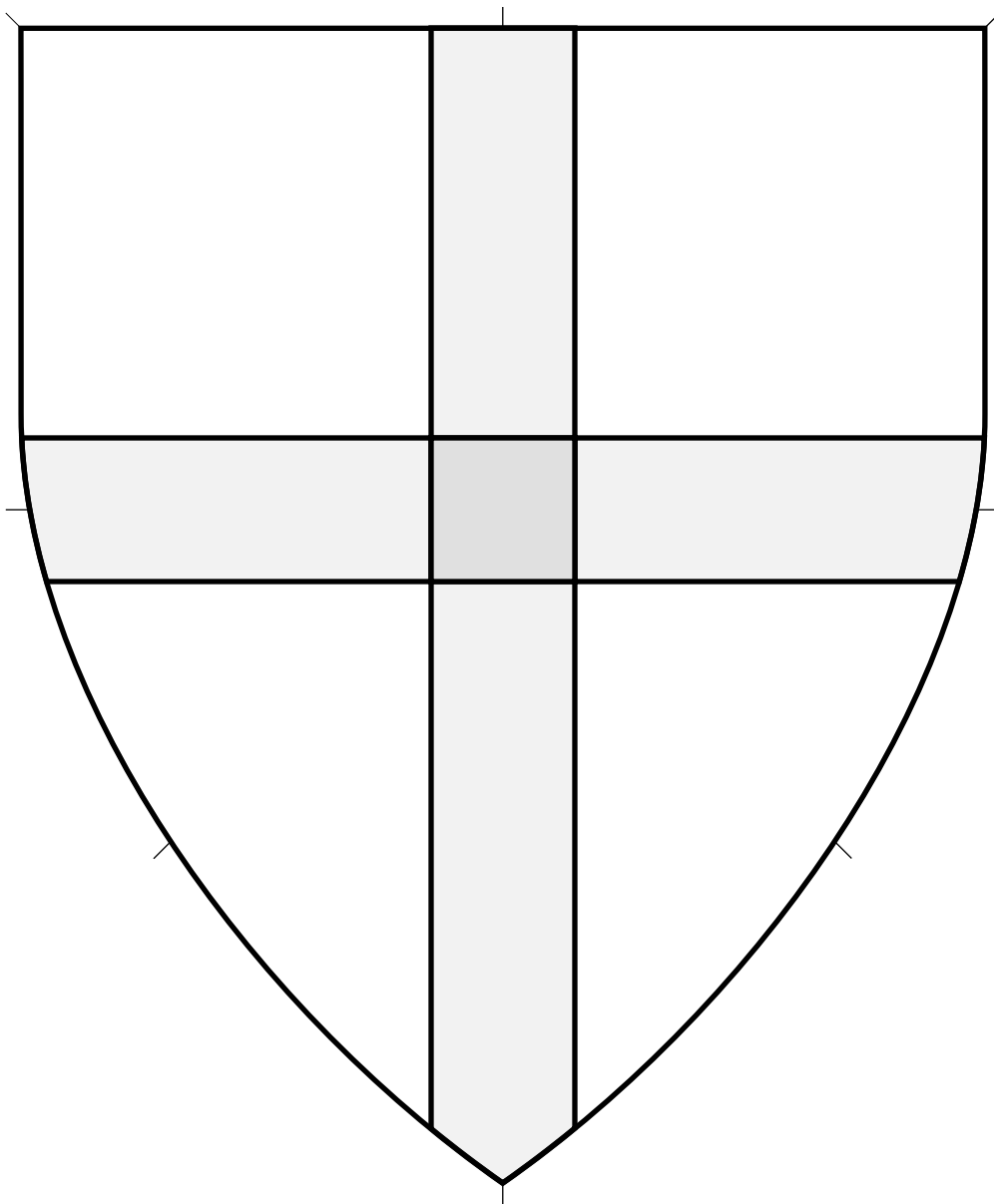

Central ordinary. A cross with its center removed.

Source: Armas de los Cavalleros de Venecia.

Artist unknown.
(Folio 97r.)

Cross Quarter-Pierced of Another Tincture 4.378

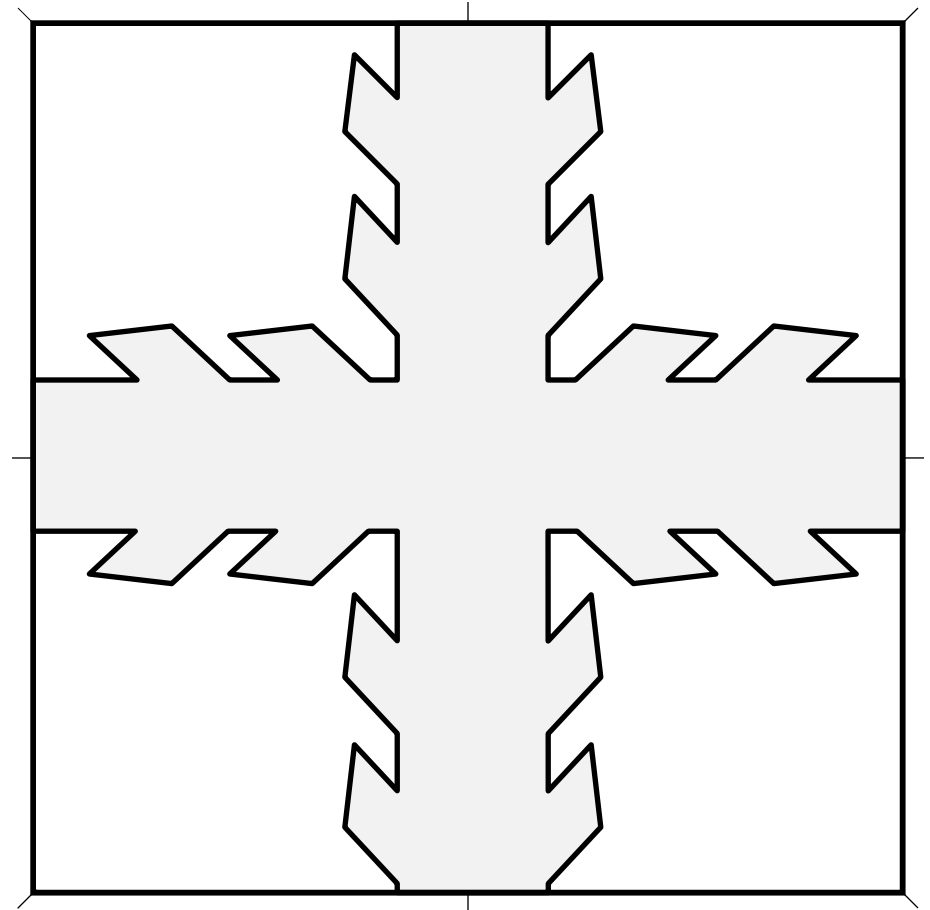
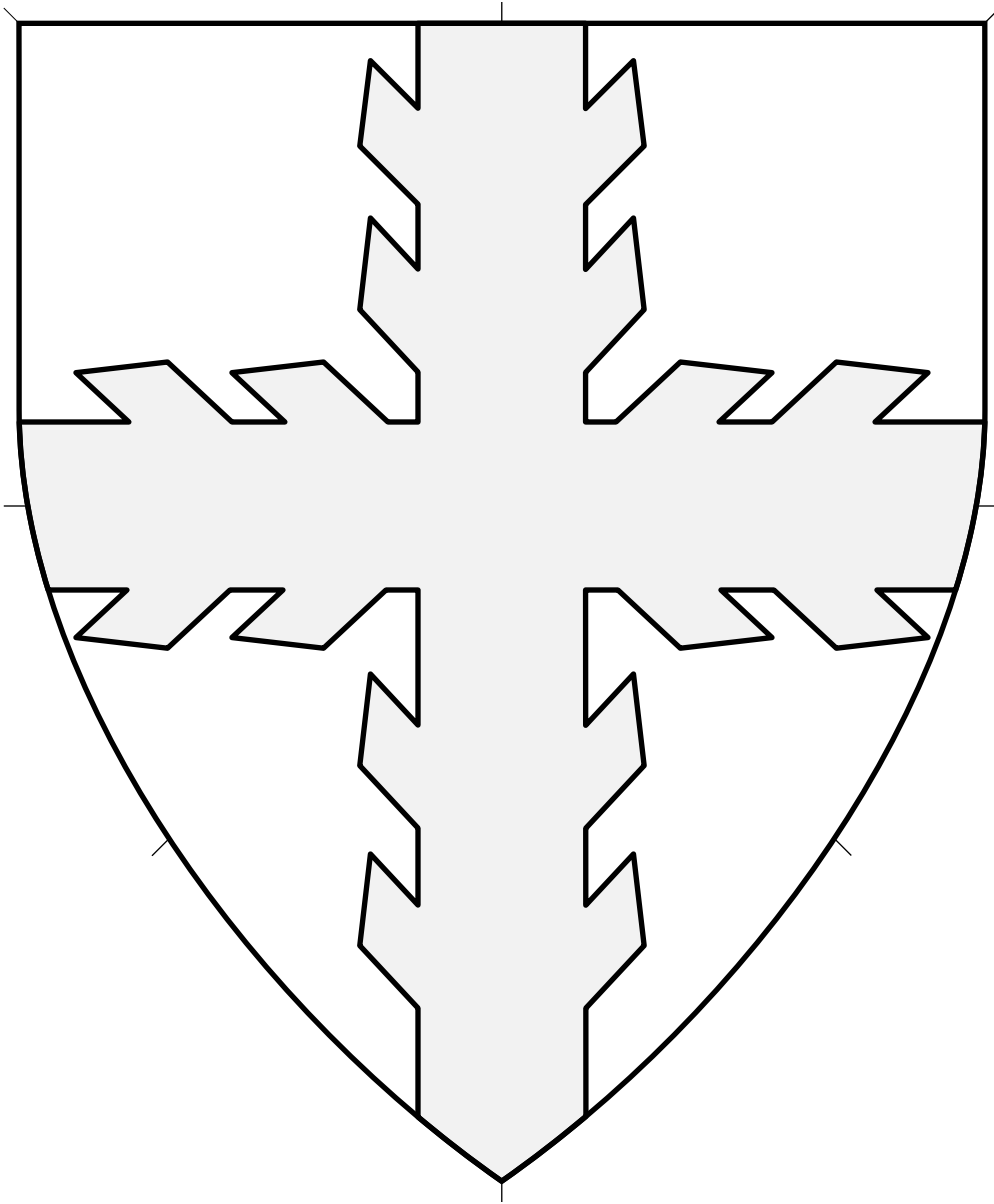

Central ordinary.
Source: Insignia Anglica. Artist unknown. (Pages 42, 62.)

Cross Raguly (1) 4.379

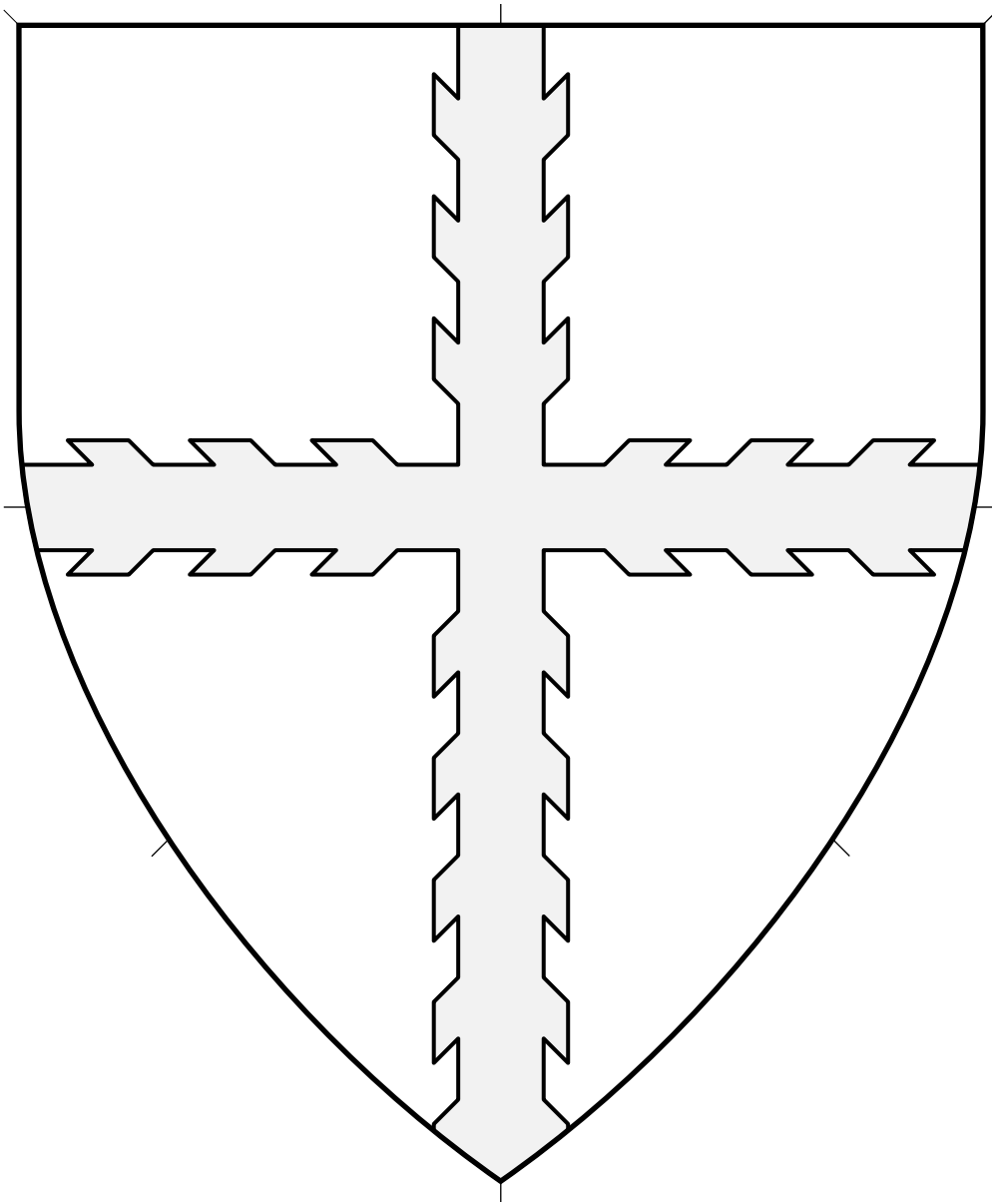

Central ordinary.

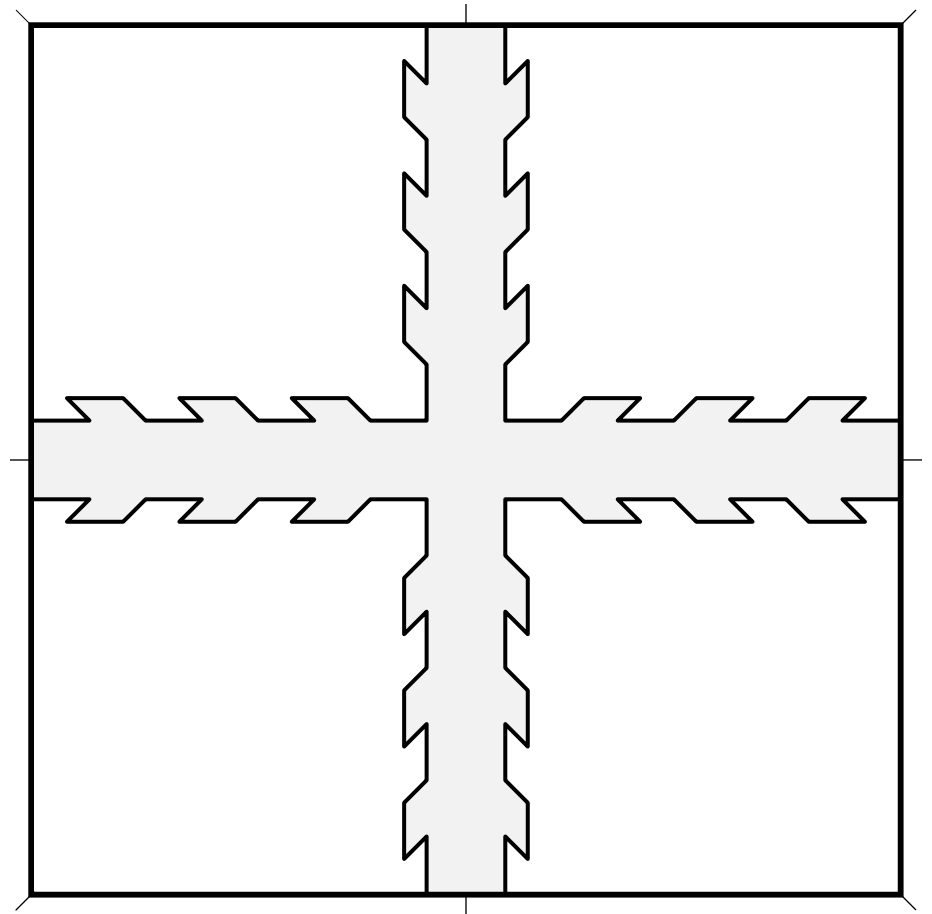

Cross Raguly (2) 4.380

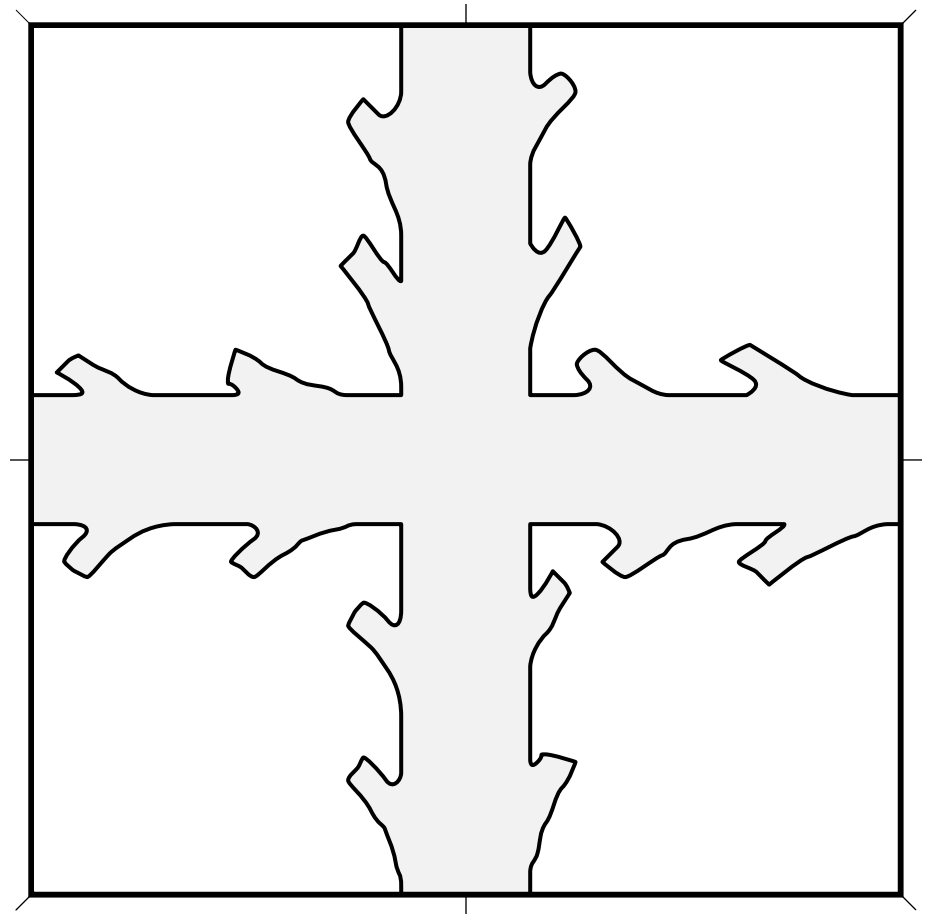
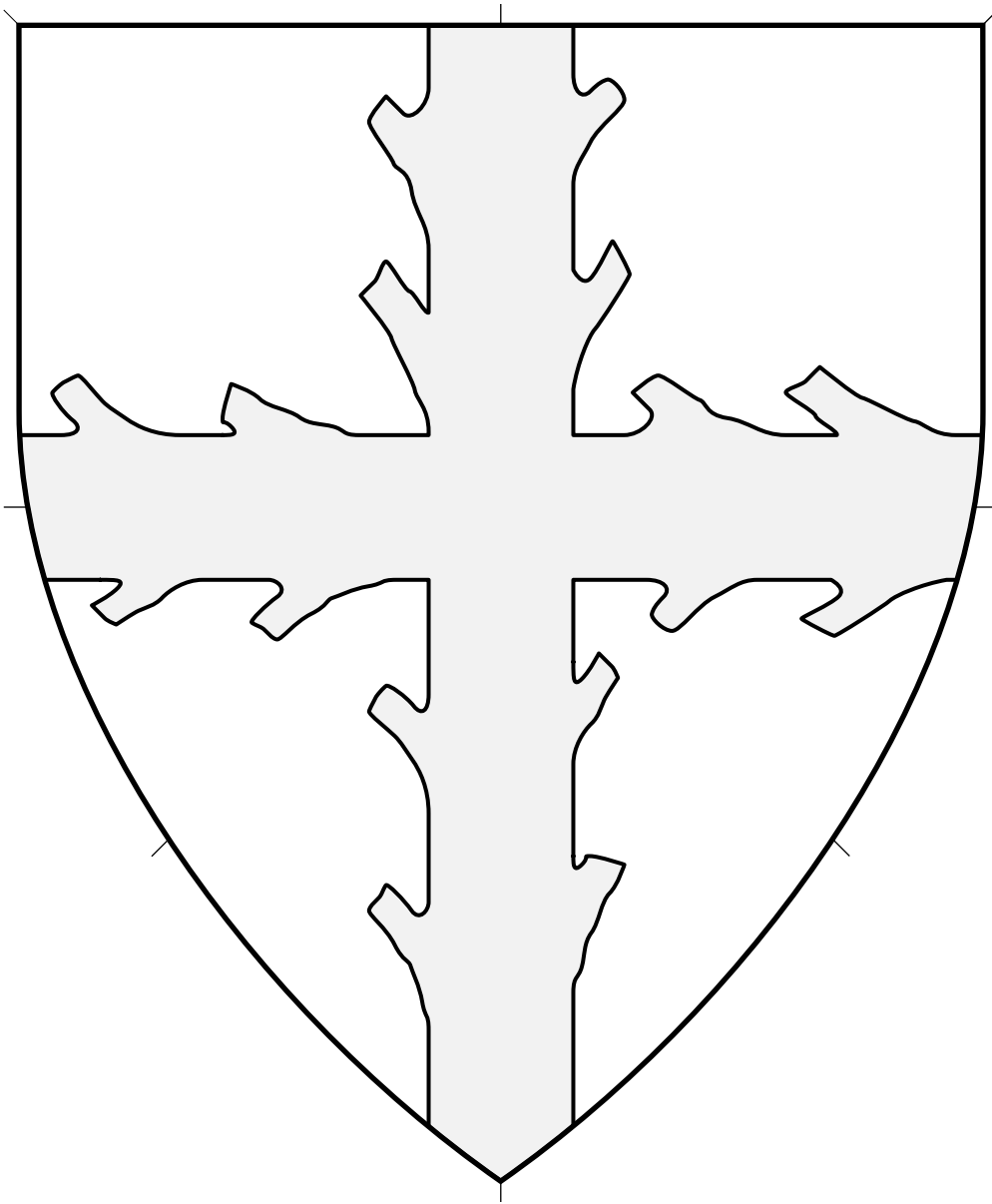

Central ordinary.

Source: Commonplace Book of Heraldry. (Folio 48v.)

Artist: Jean Faucket. Adapted by Mathghamhain Ua Ruadháin.

Cross Raguly (3) 4.381

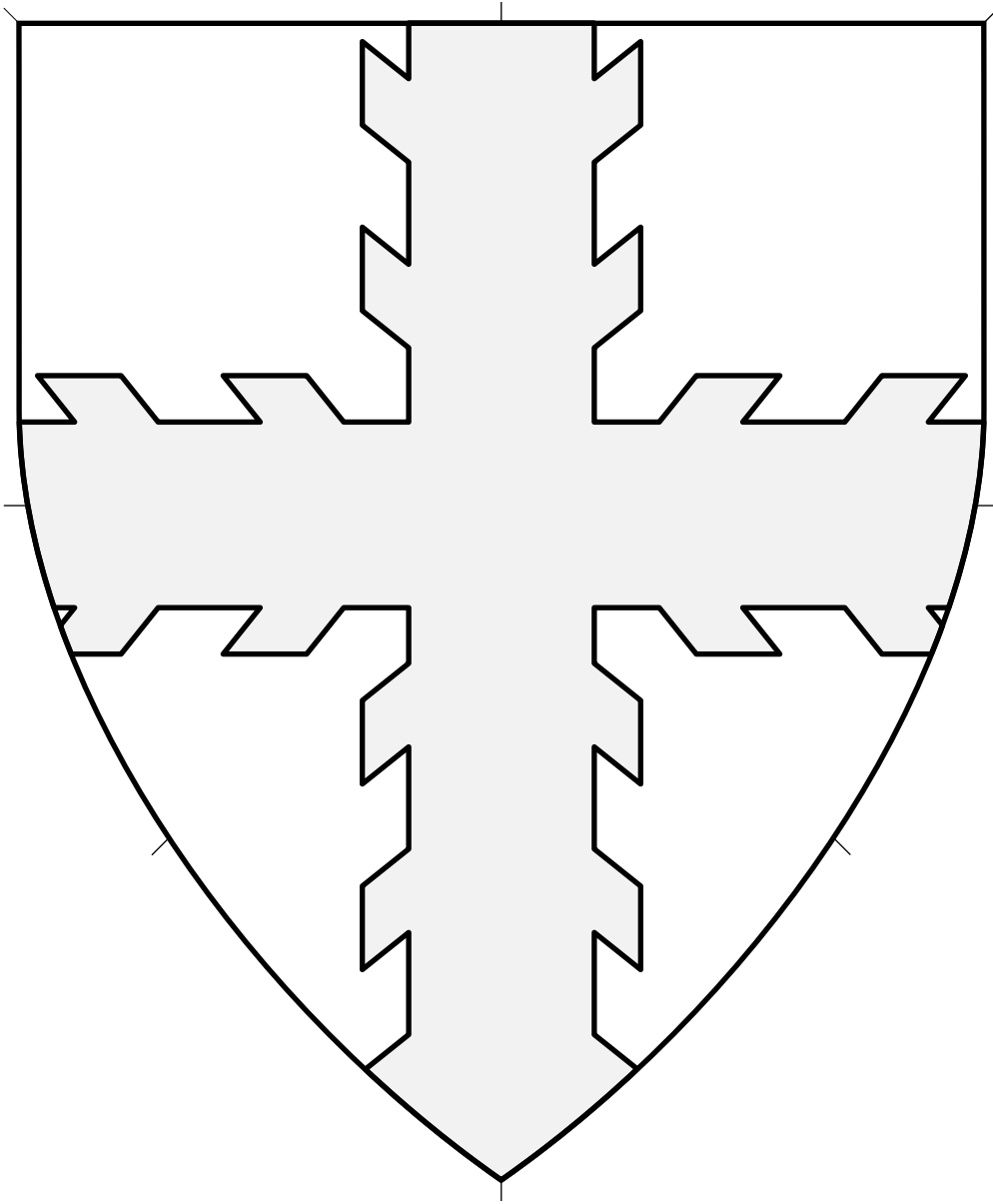

Central ordinary.

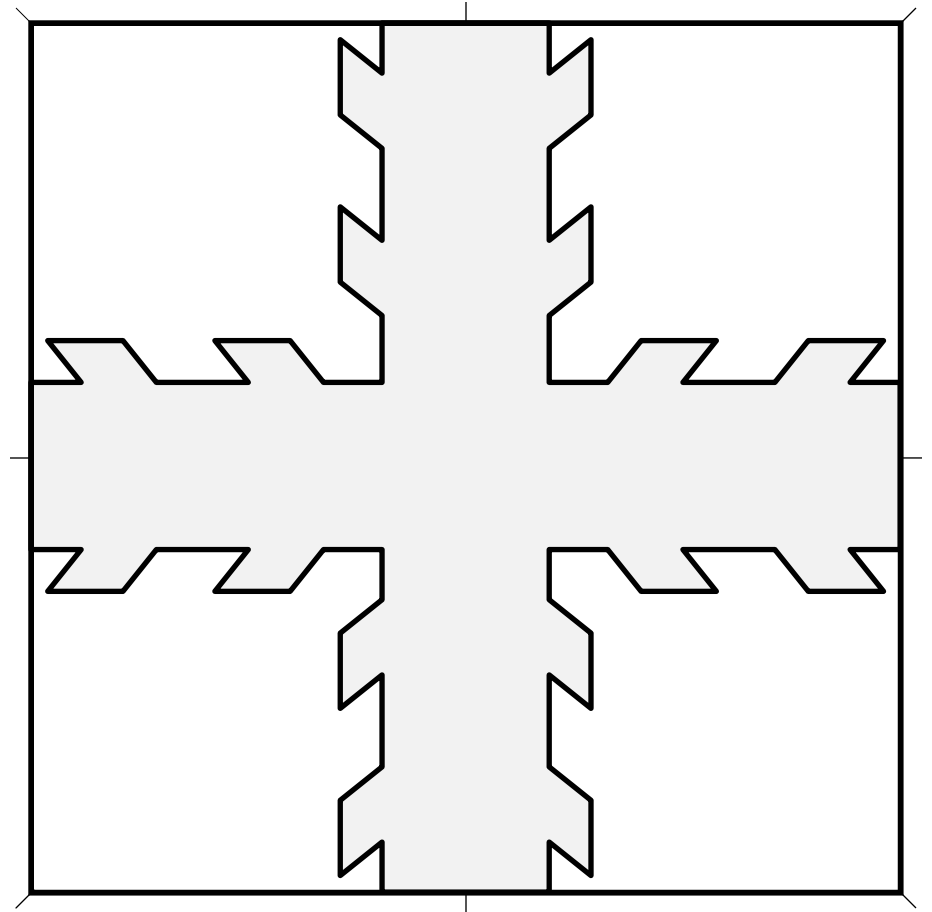

Cross Raguly (4) 4.382

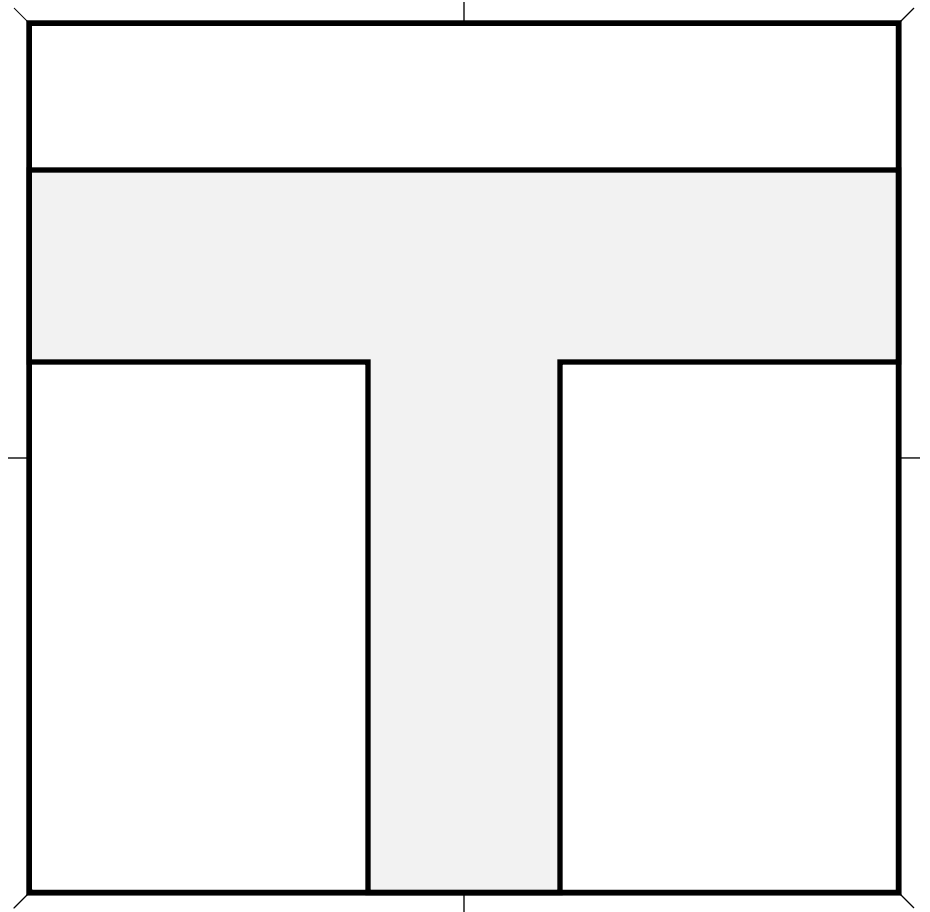
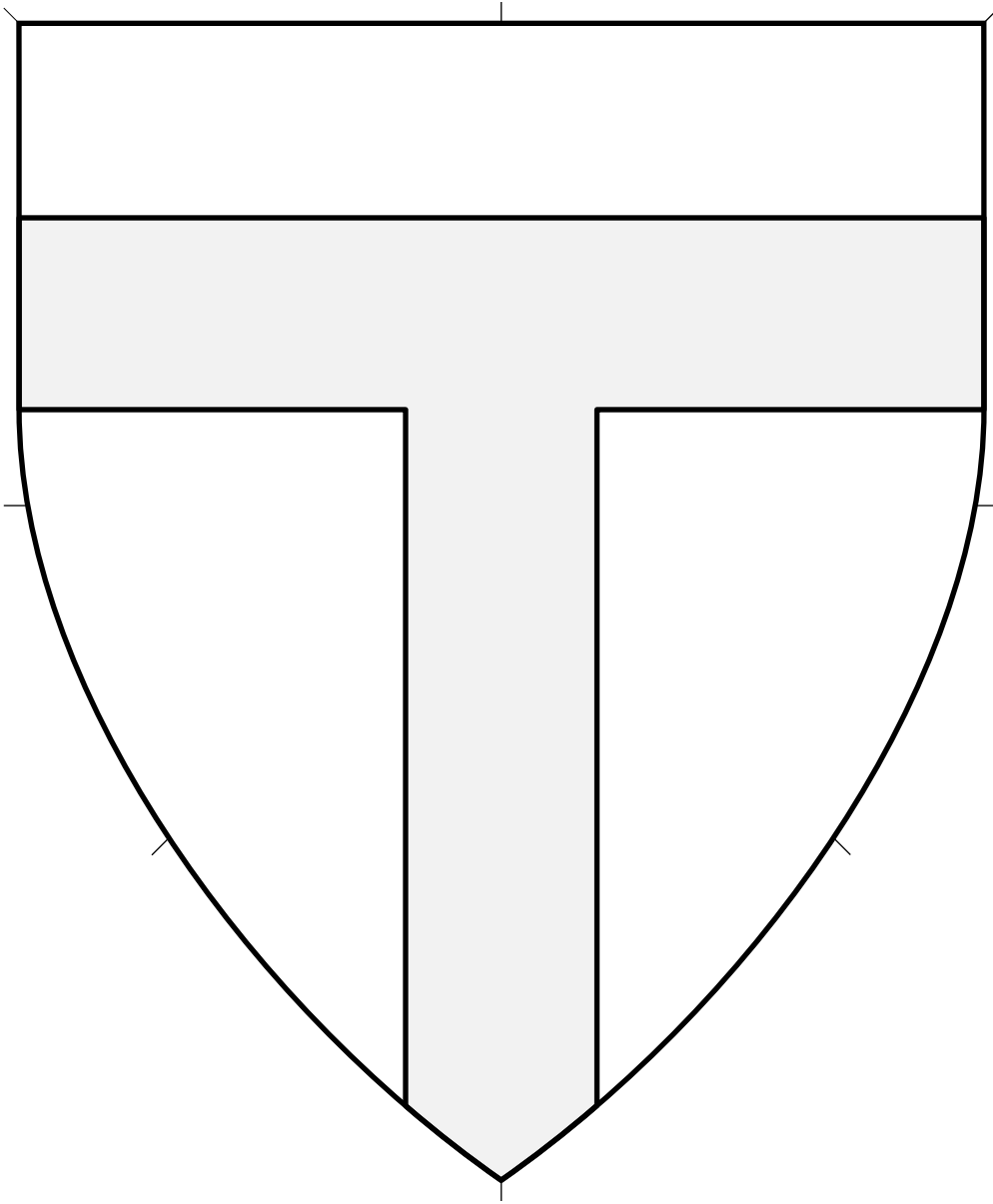

Central ordinary.

Cross, Straight Tau, Throughout 4.383

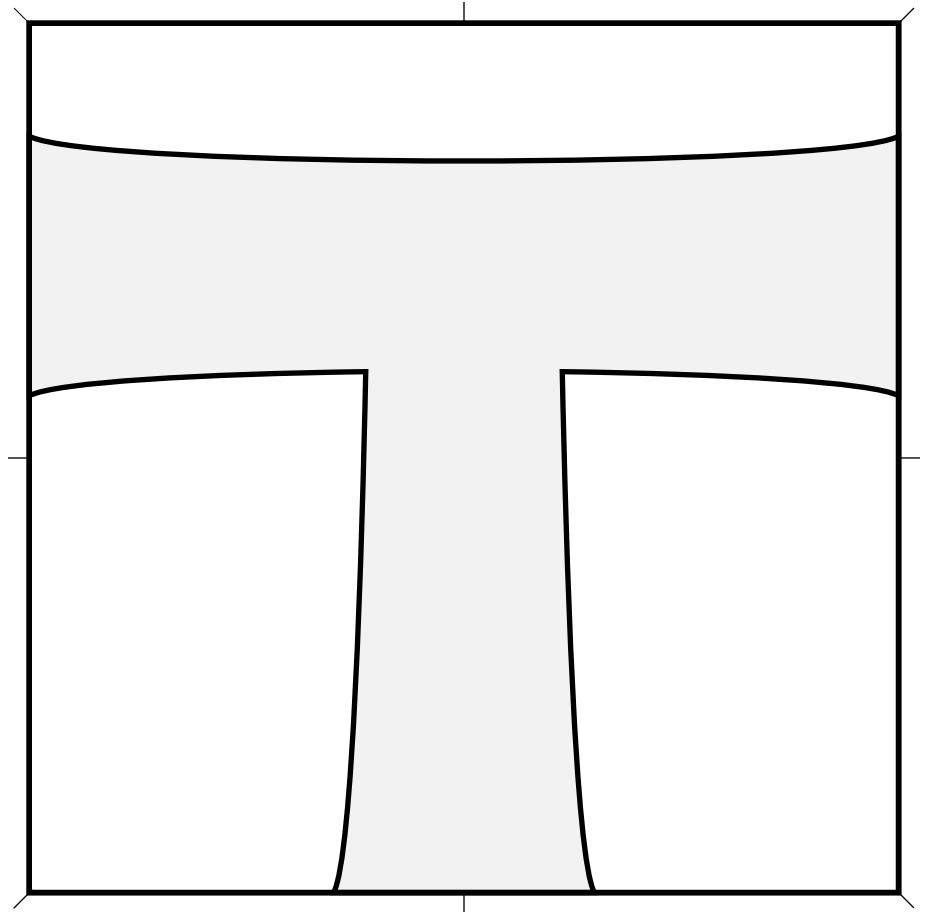
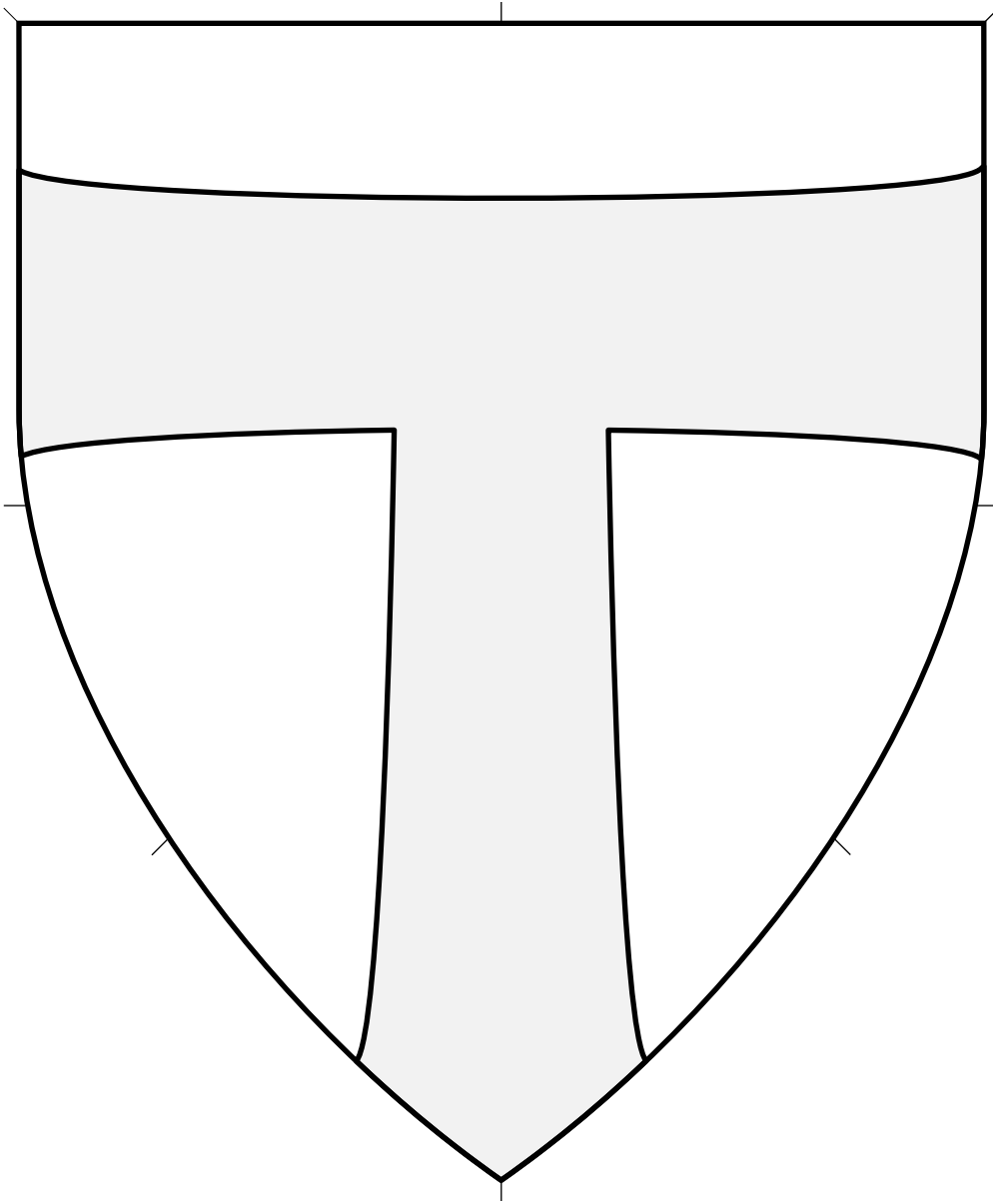

Central ordinary.

Cross, Tau, Throughout 4.384

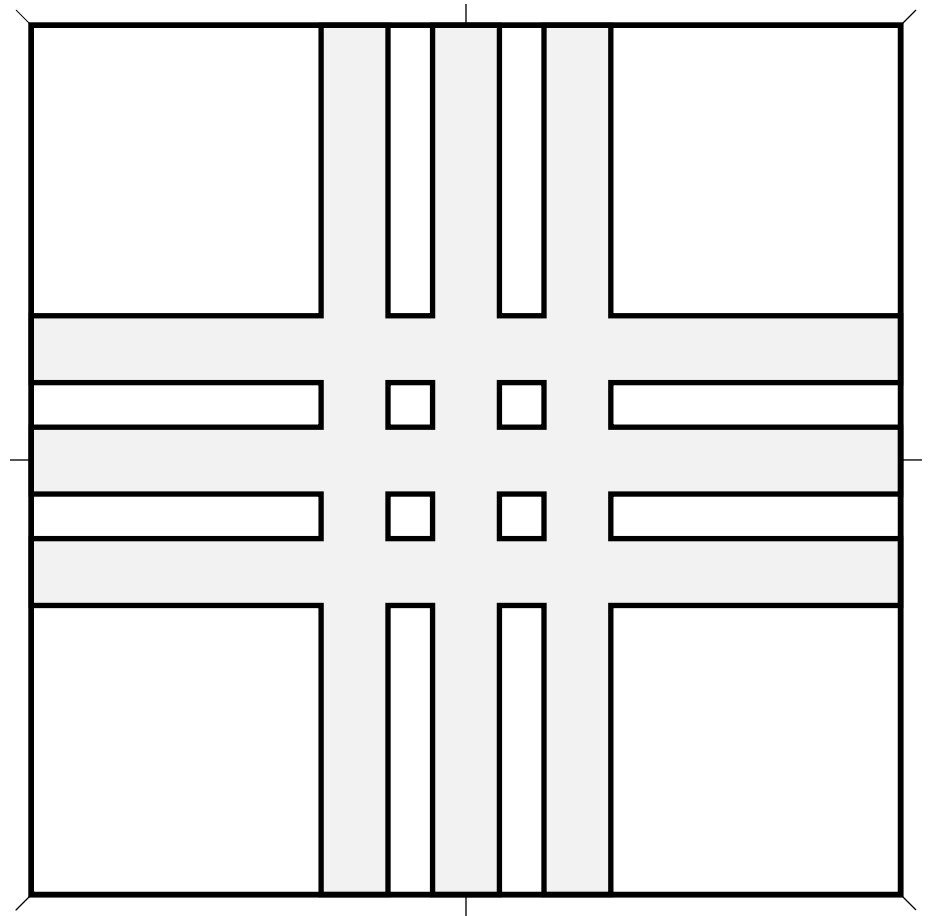
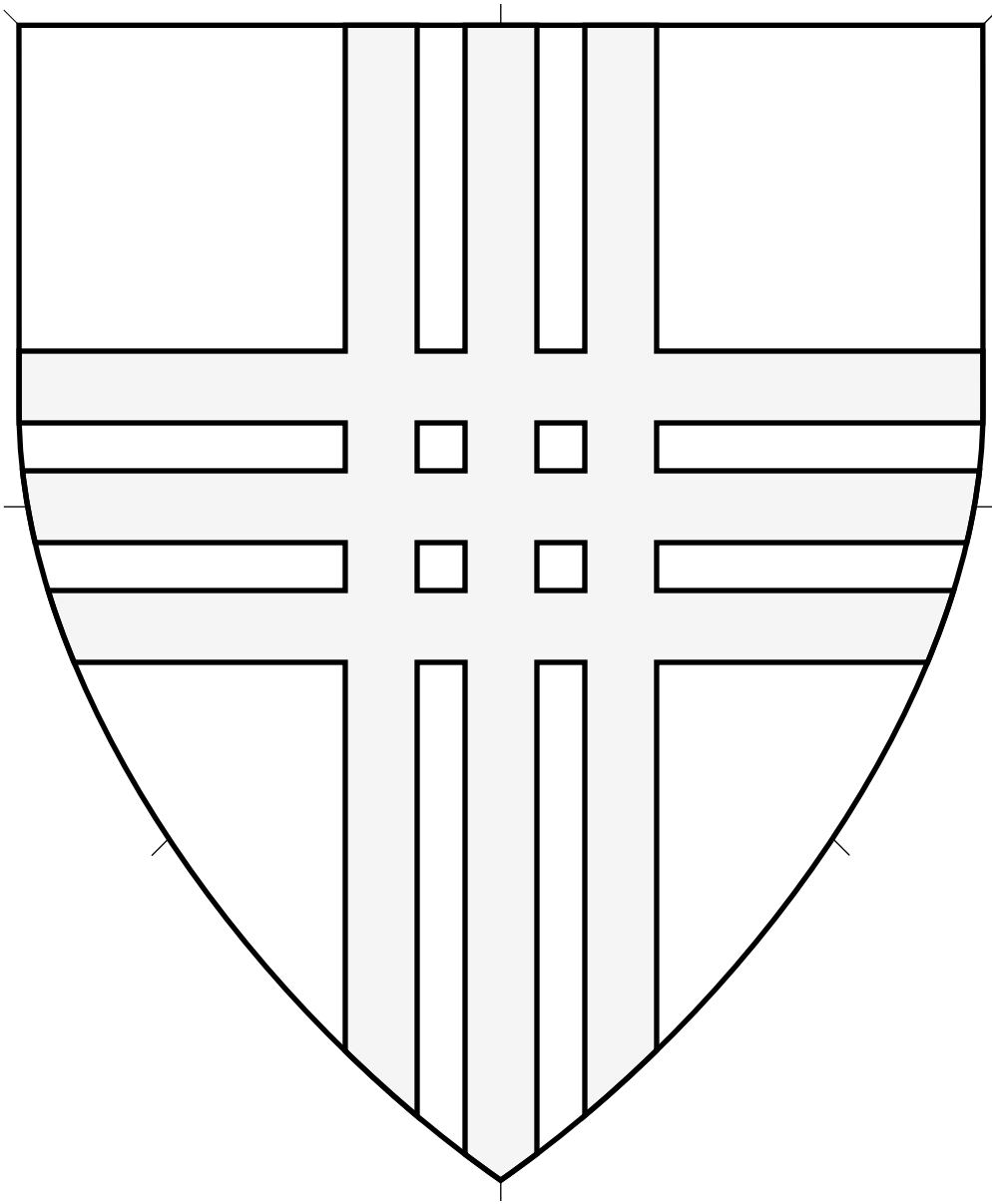

Central ordinary. A cross formed of three bars and three pales, conjoined.

Cross Triply Parted 4.385

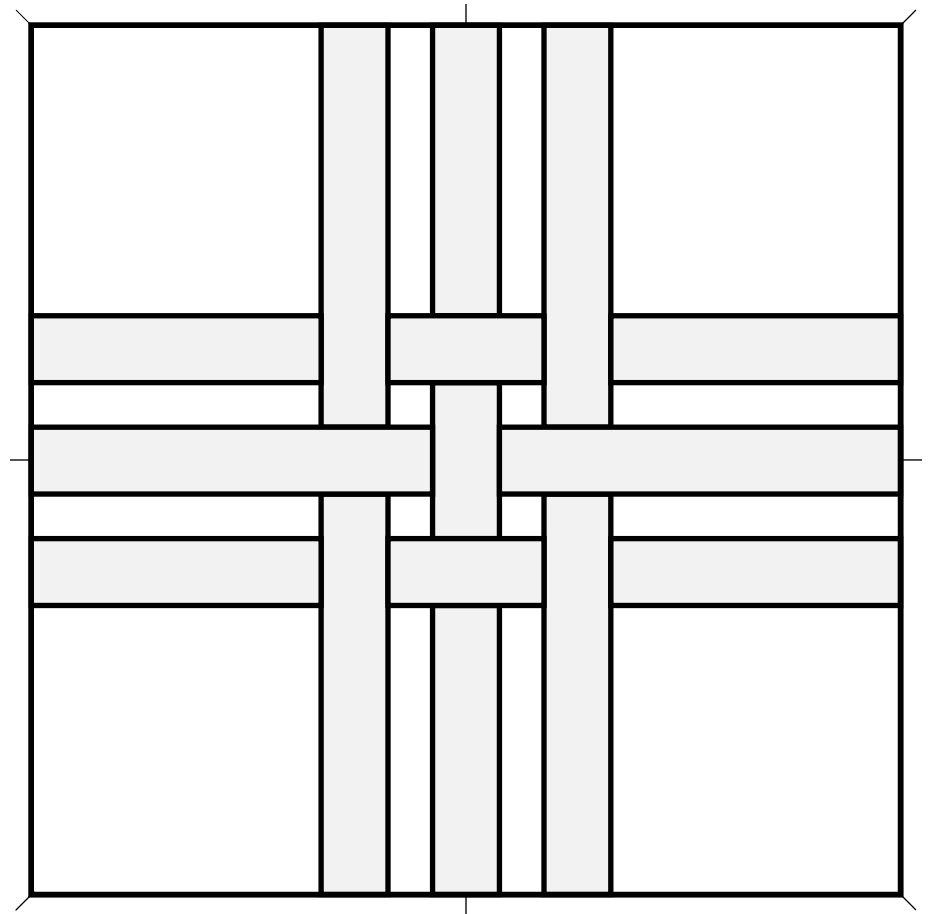
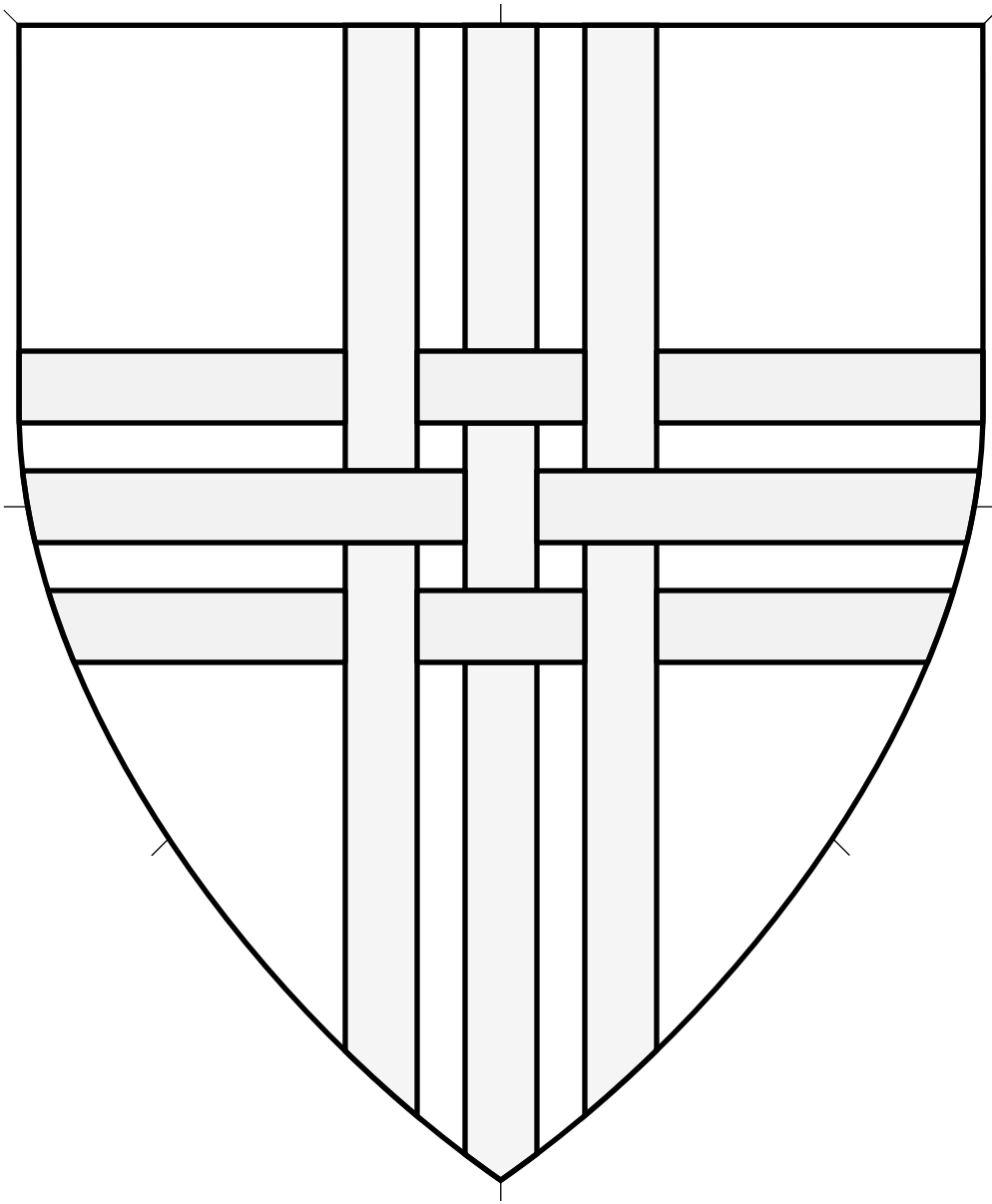

Central ordinary. A cross which has been split into interlaced strips.

Cross Triply Parted and Fretted 4.386

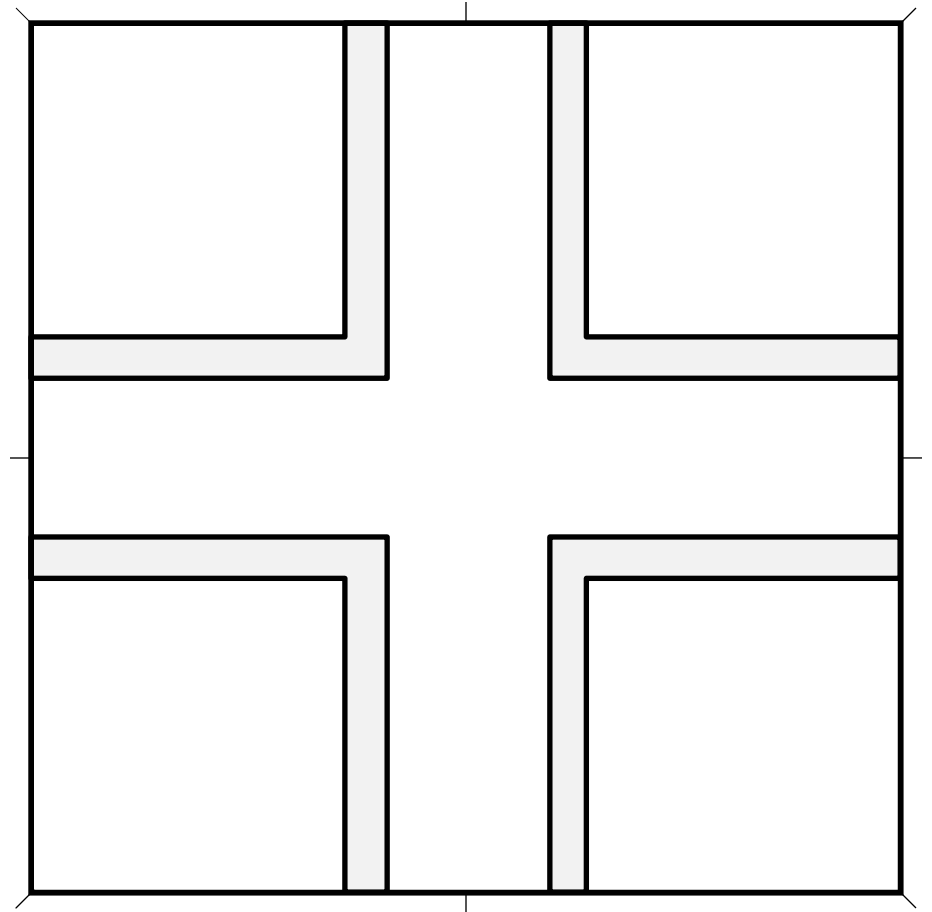
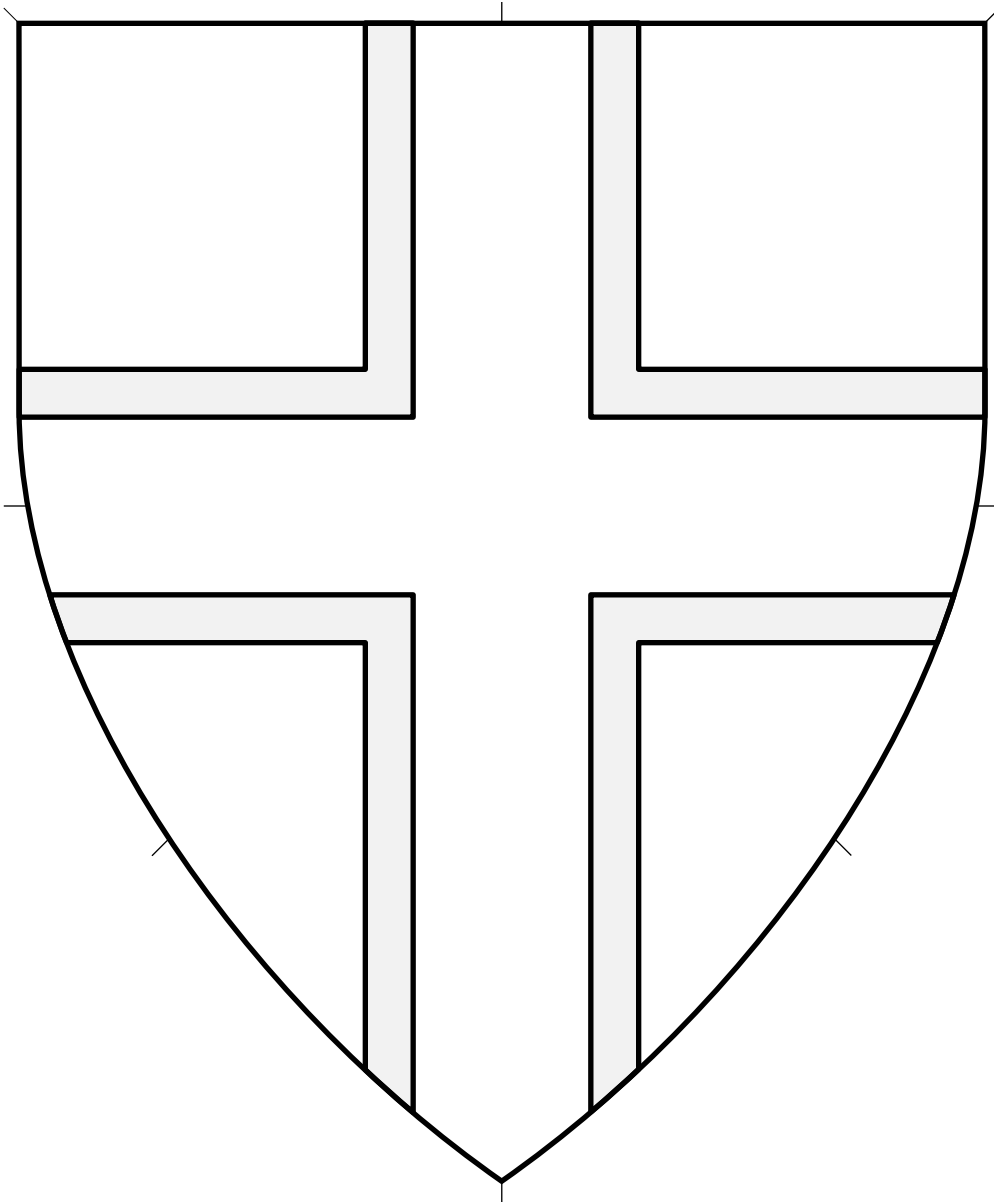

Central ordinary.

Cross Voided 4.387

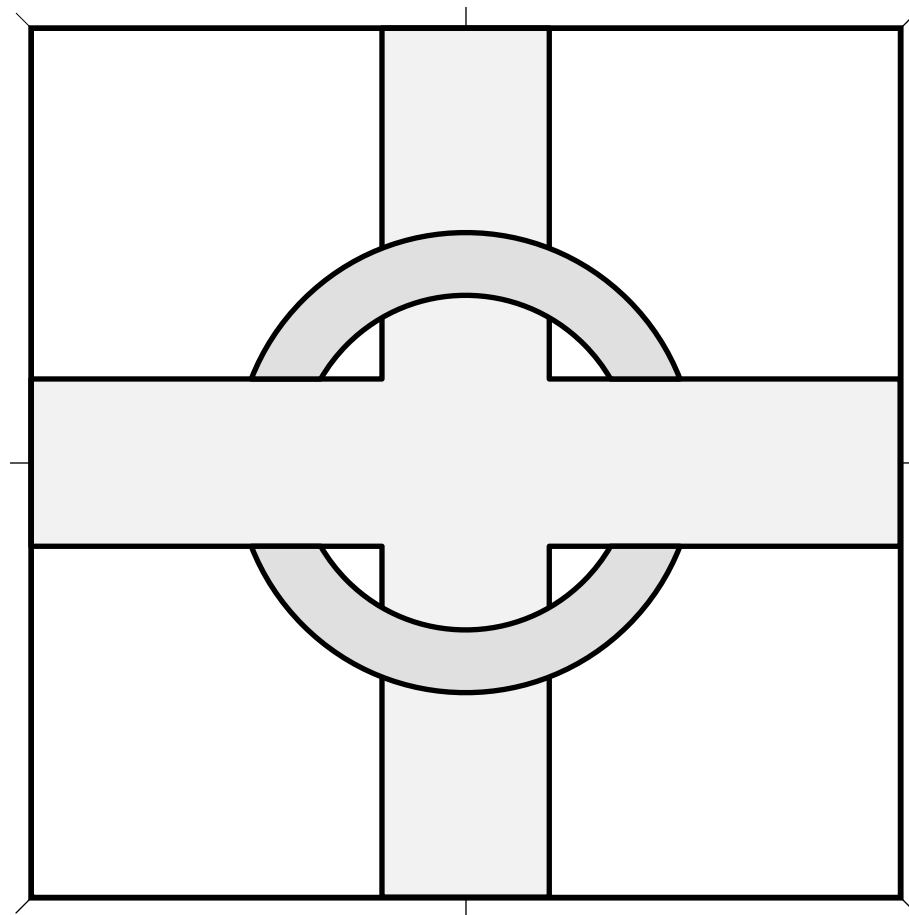
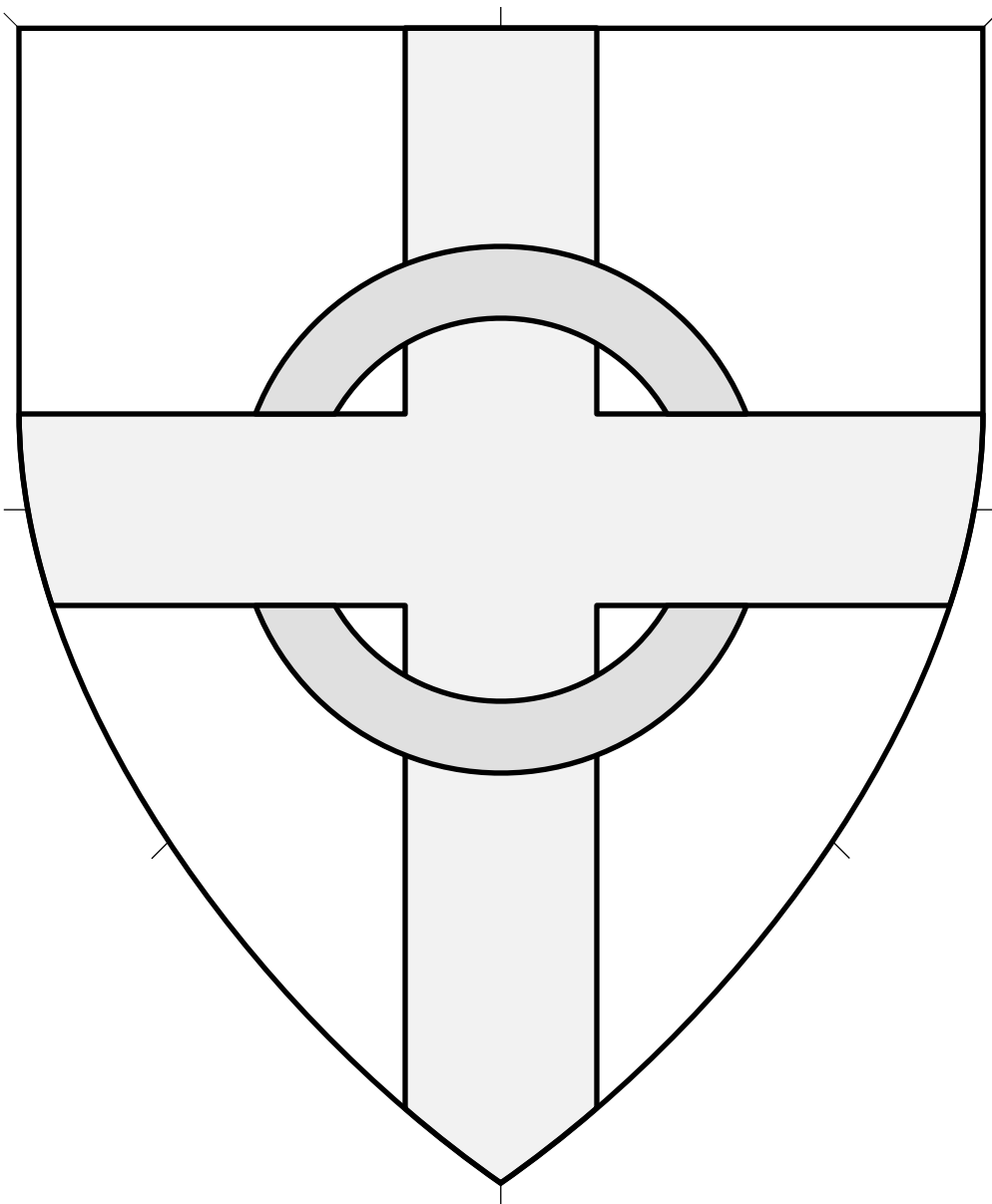

Central ordinary and surrounding charge.

Source: Encyclopædia Heraldica.
(Volume 3, plate XXXV.) Artist unknown.

Cross Interlaced with an Annulet 4.388

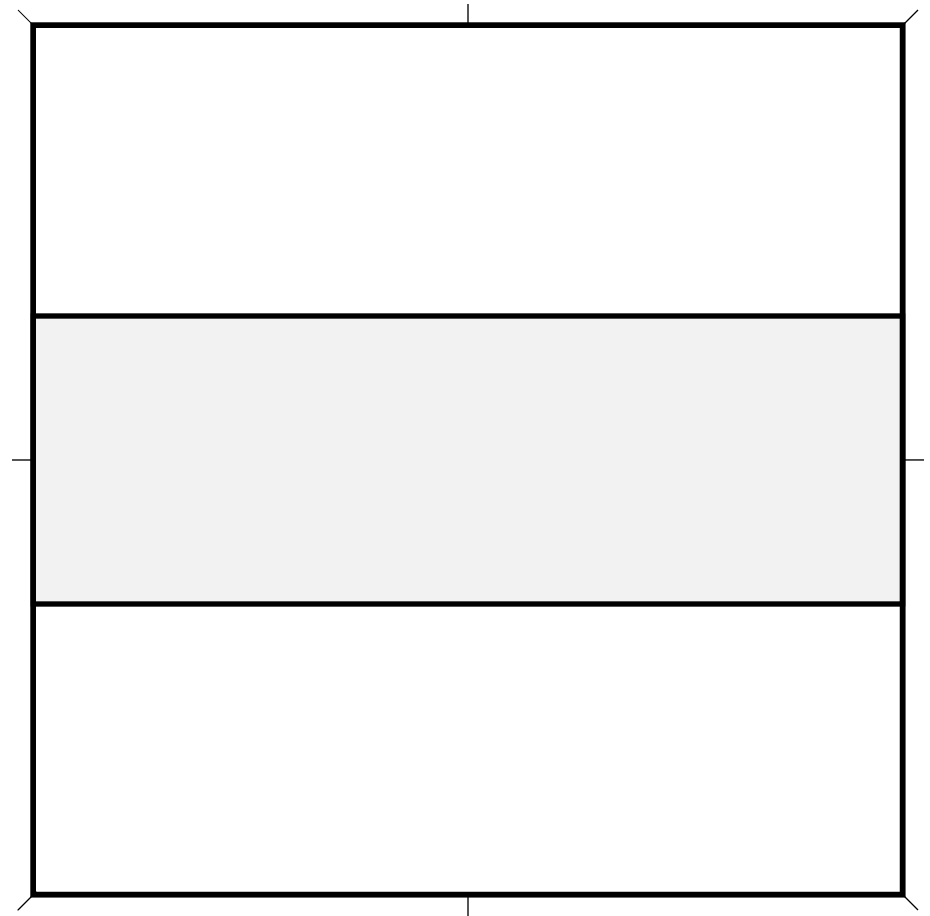
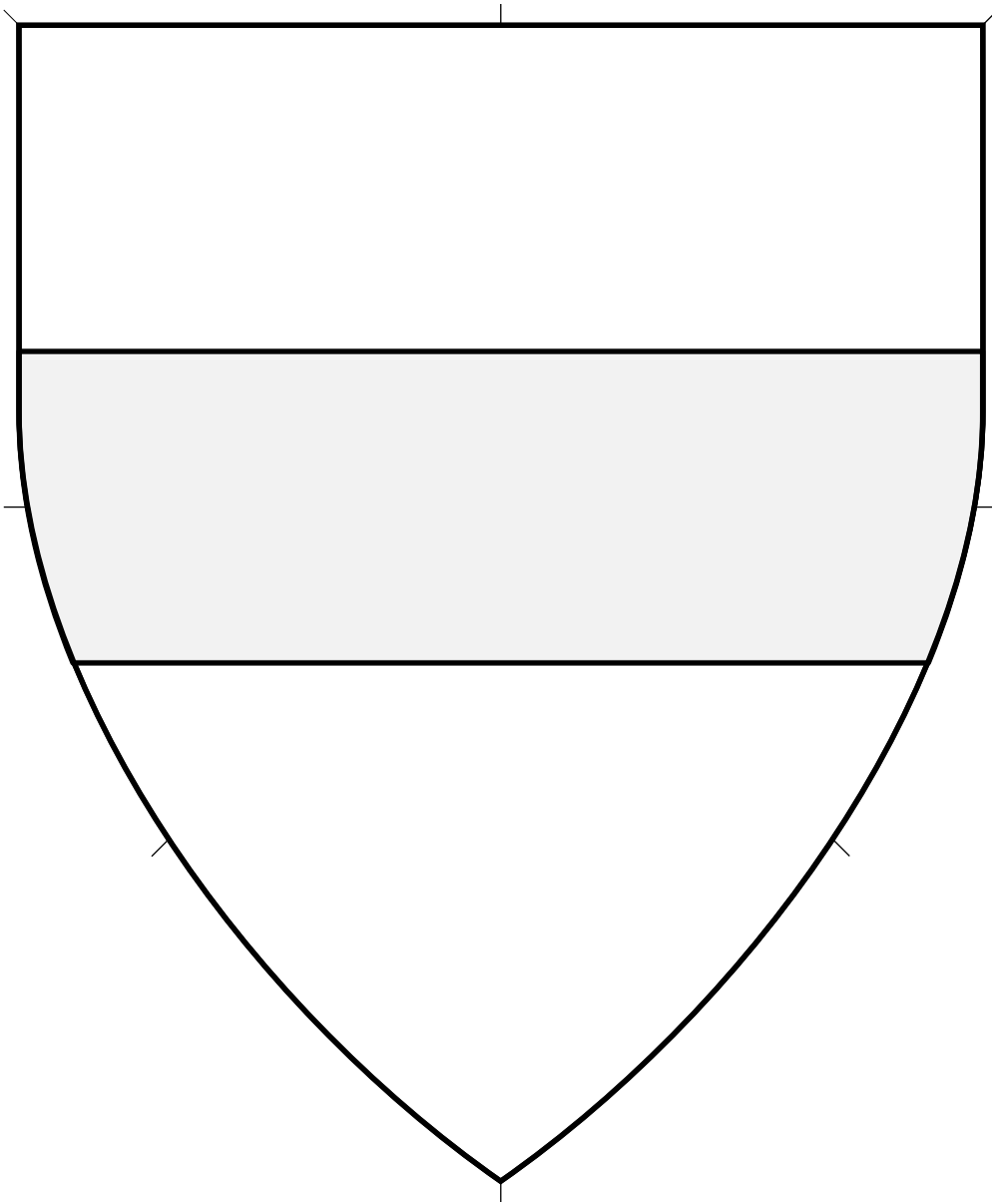

Central ordinary. The height is typically a third of the width of the device or a bit narrower.
This is a thin fess.

Should be centered on the fess line, with minor adjustments to accommodate secondary charges.

Fess (1) 4.389

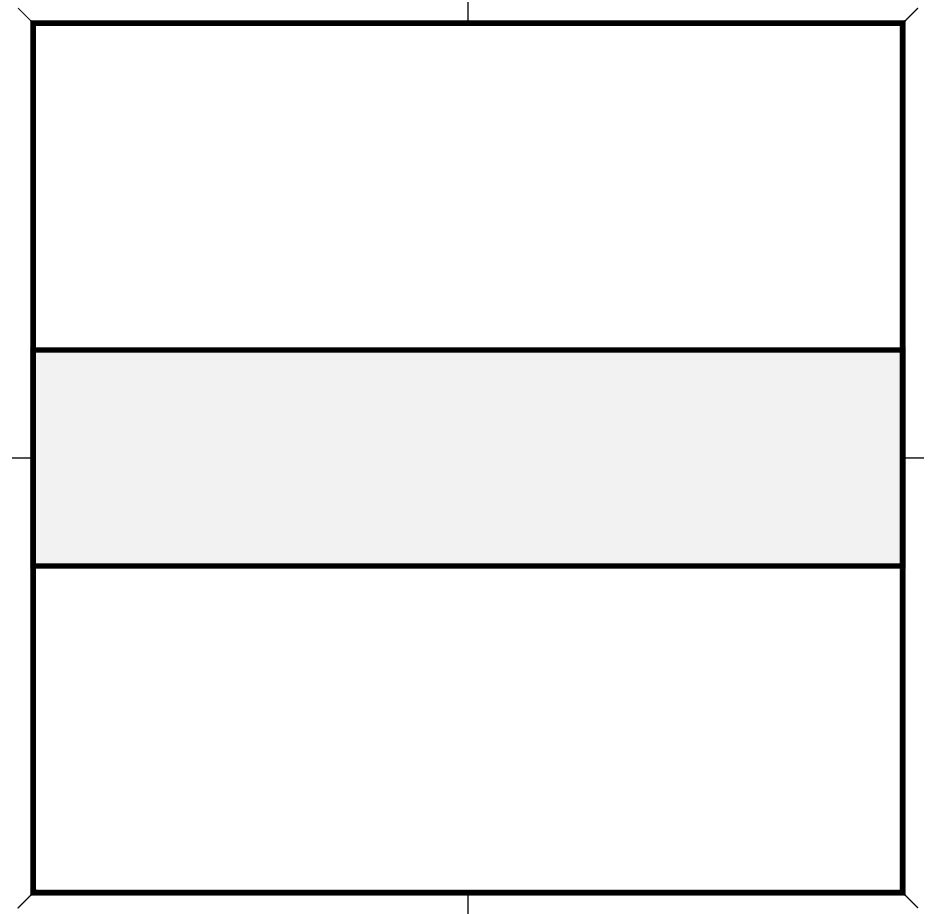
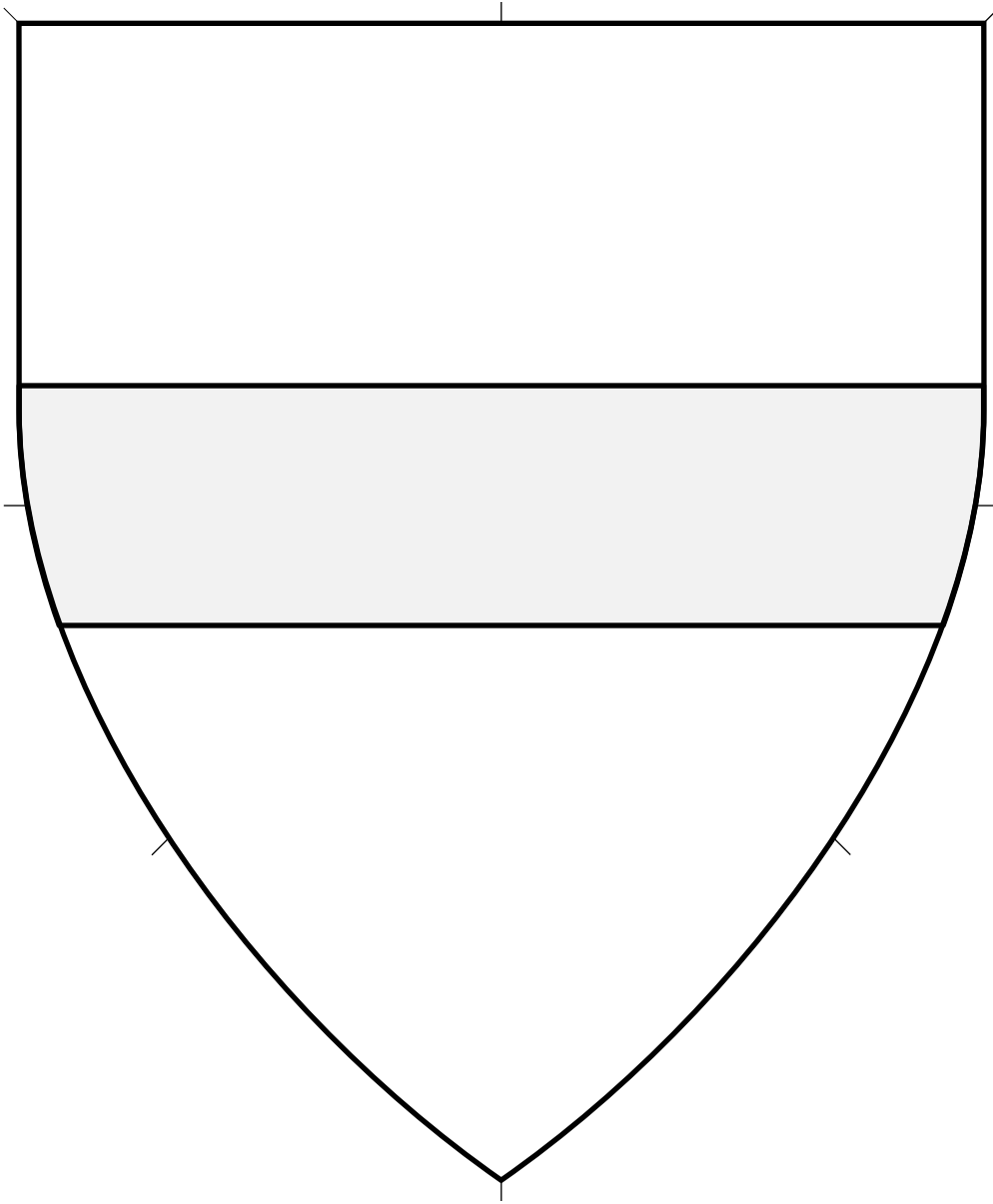

Central ordinary. The height is typically a third of the width of the device or a bit narrower.
This is a thin fess.

Should be centered on the fess line, with minor adjustments to accommodate secondary charges.

Fess (2) 4.390

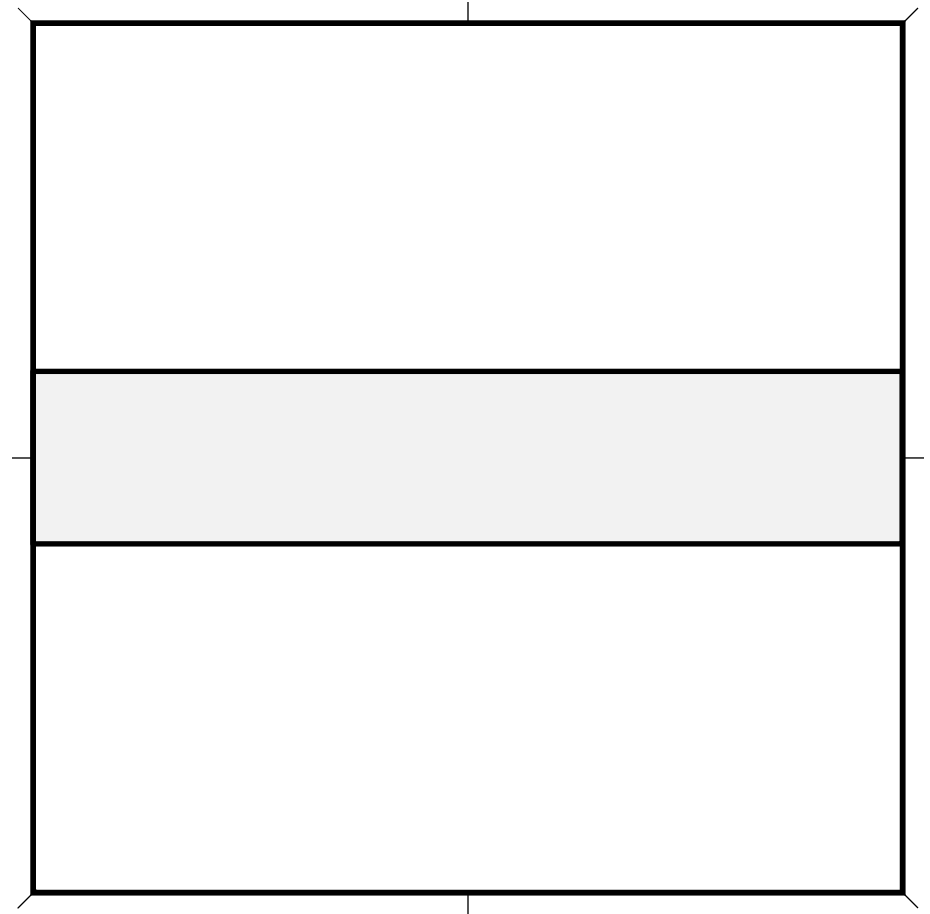
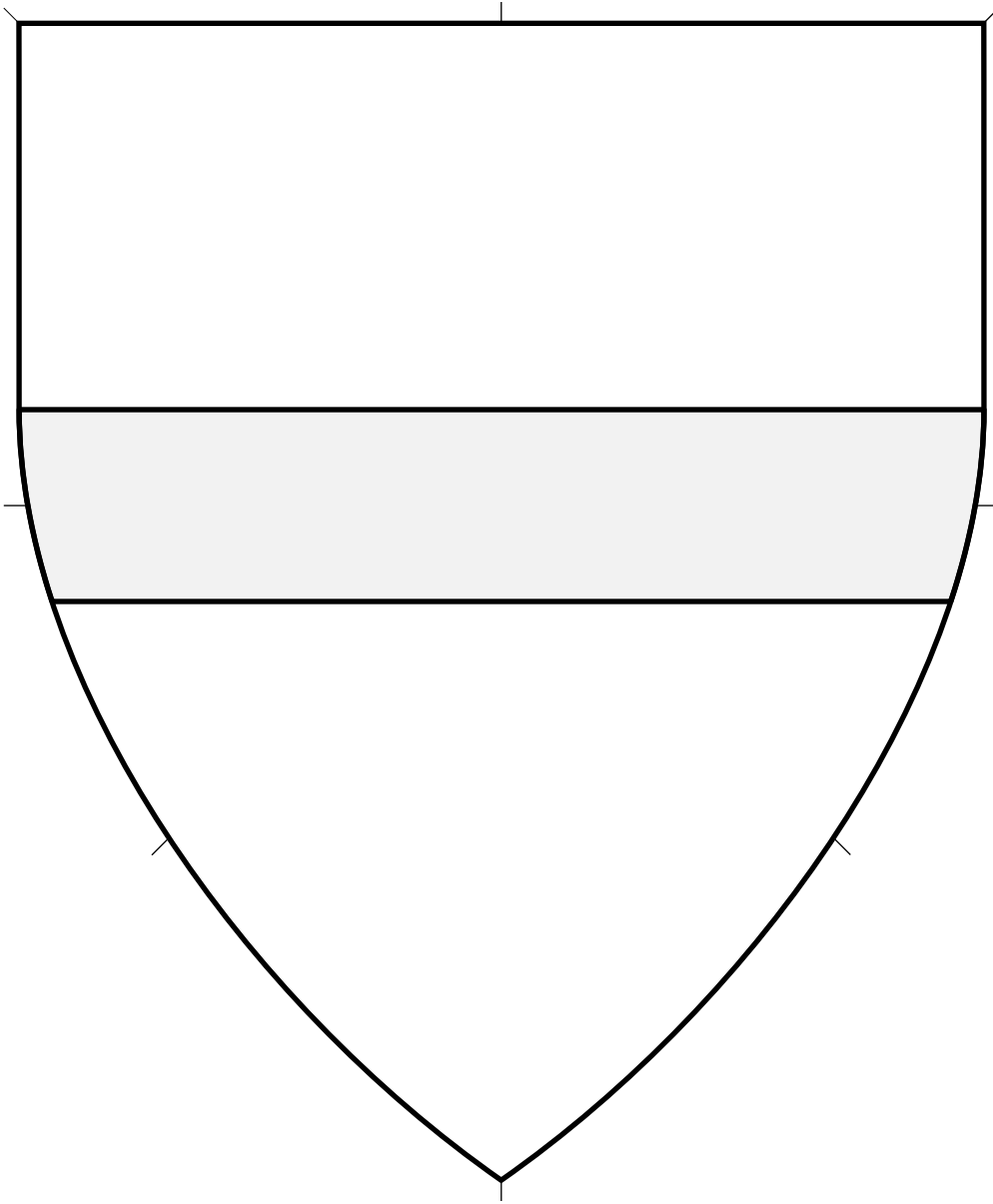

Central ordinary. The height is typically a third of the width of the device or a bit narrower.
This is a thin fess.

Should be centered on the fess line, with minor adjustments to accommodate secondary charges.

Fess (3) 4.391

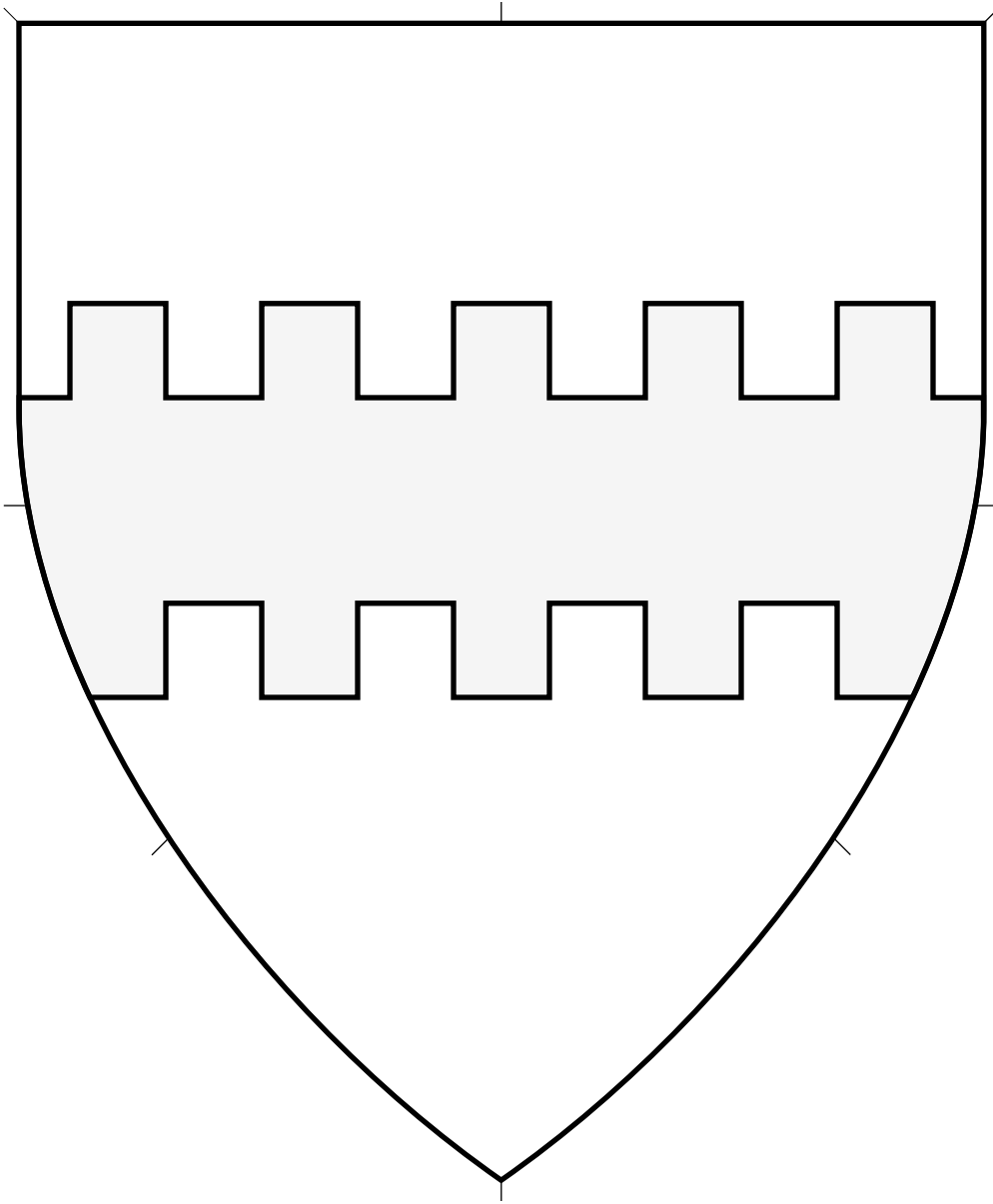

Central ordinary.

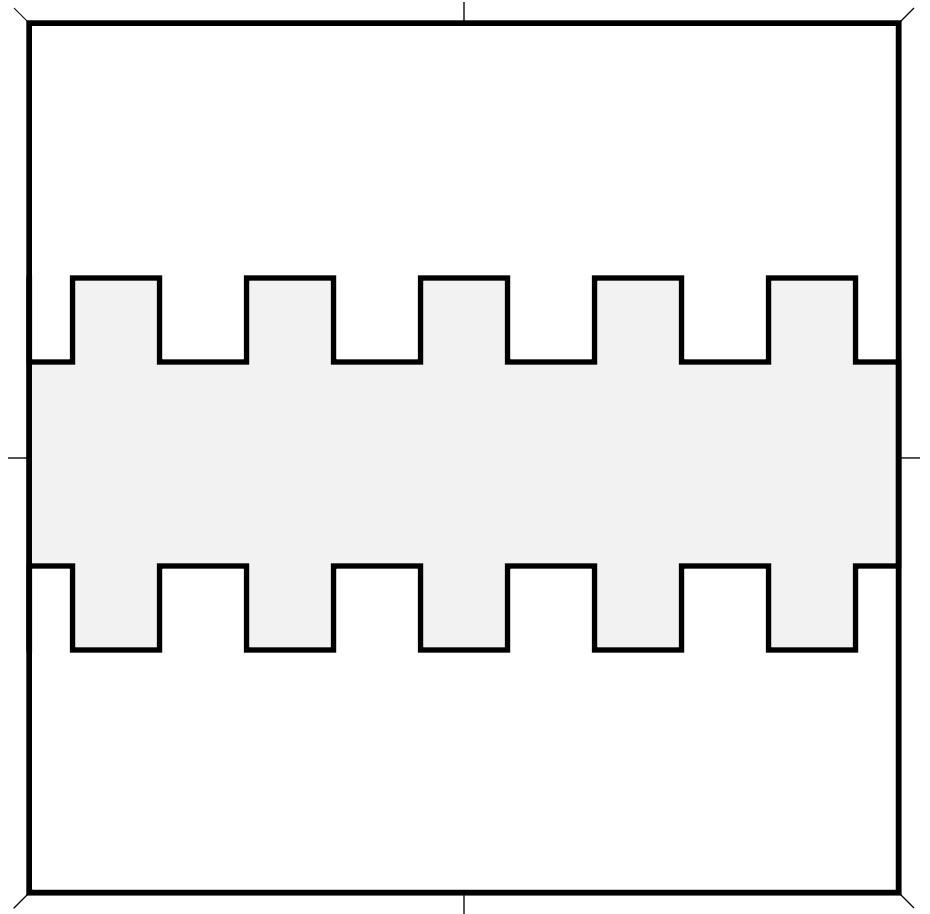

Fess Breasted 4.392

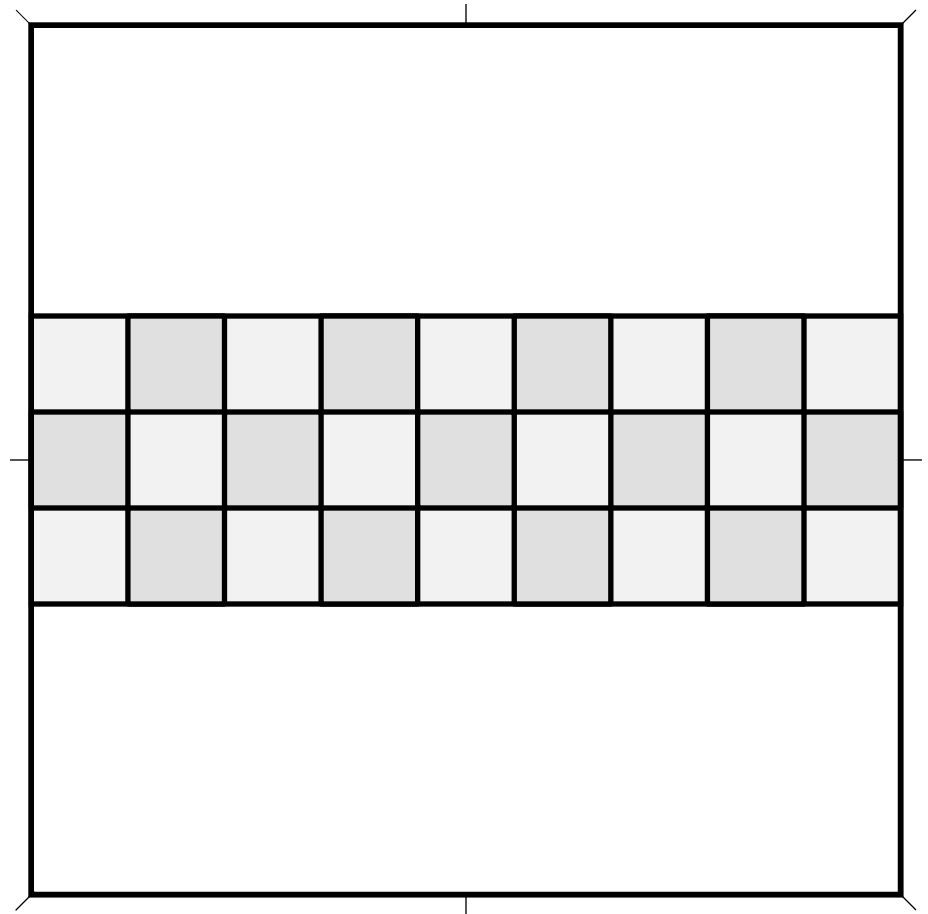
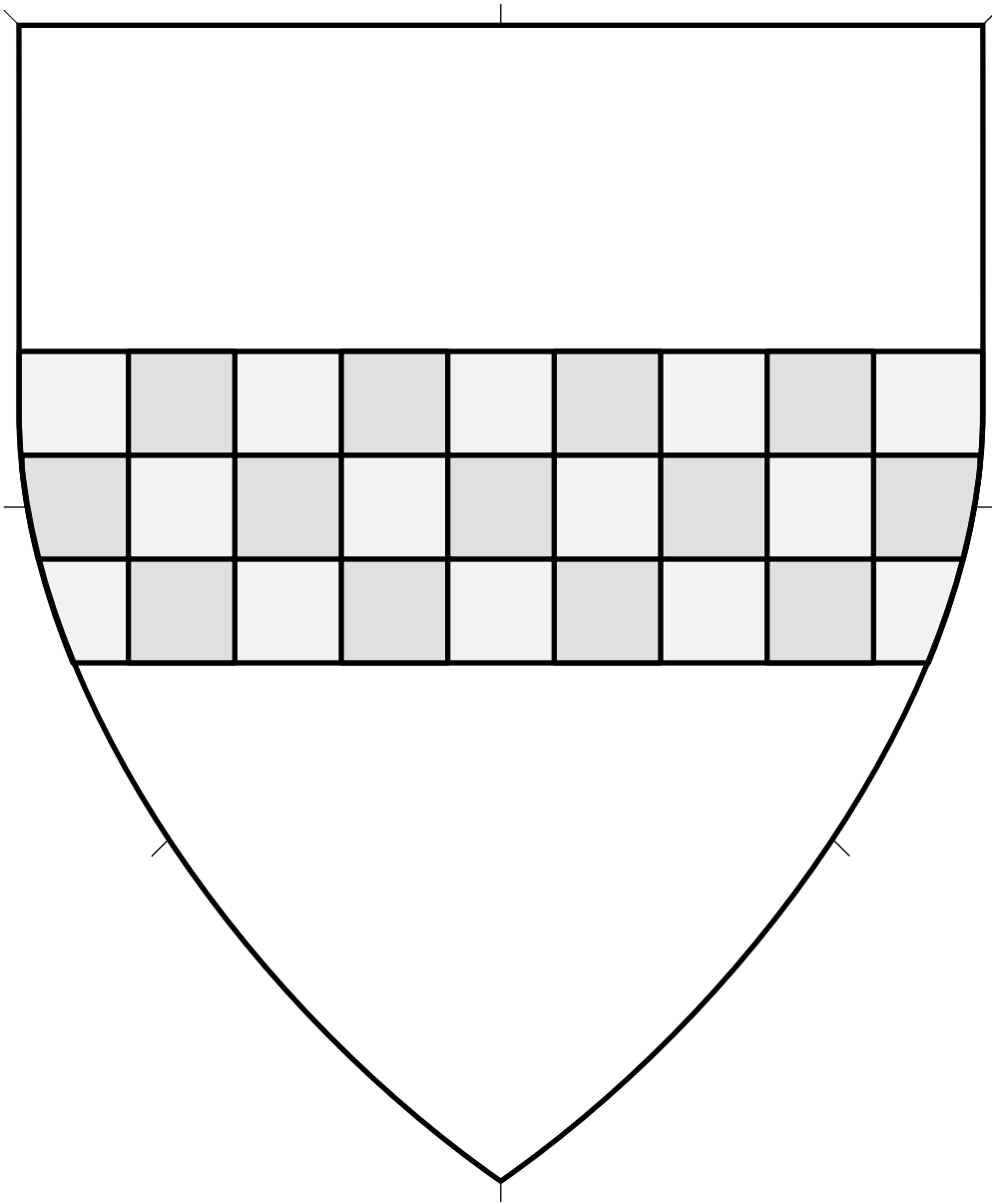

Central ordinary. Two contrasting tinctures.

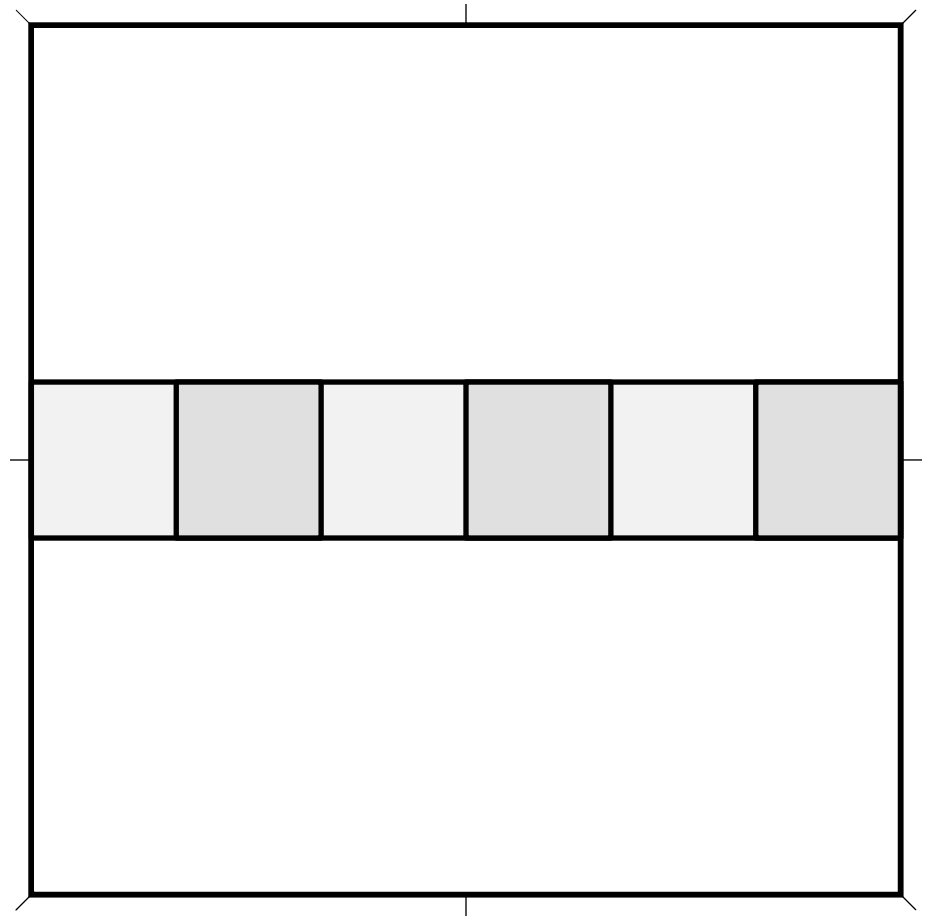
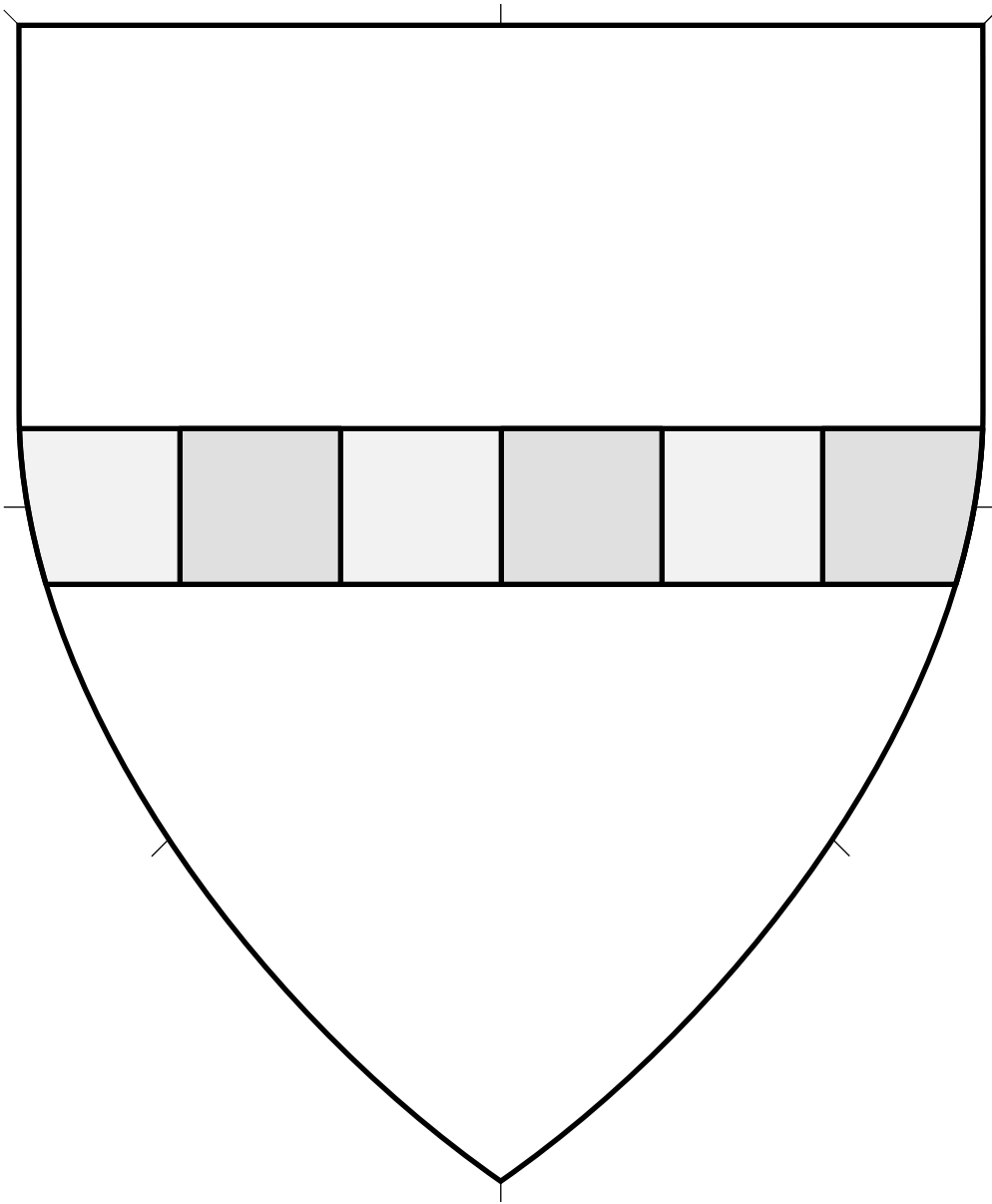

Central ordinary. Two contrasting tinctures.

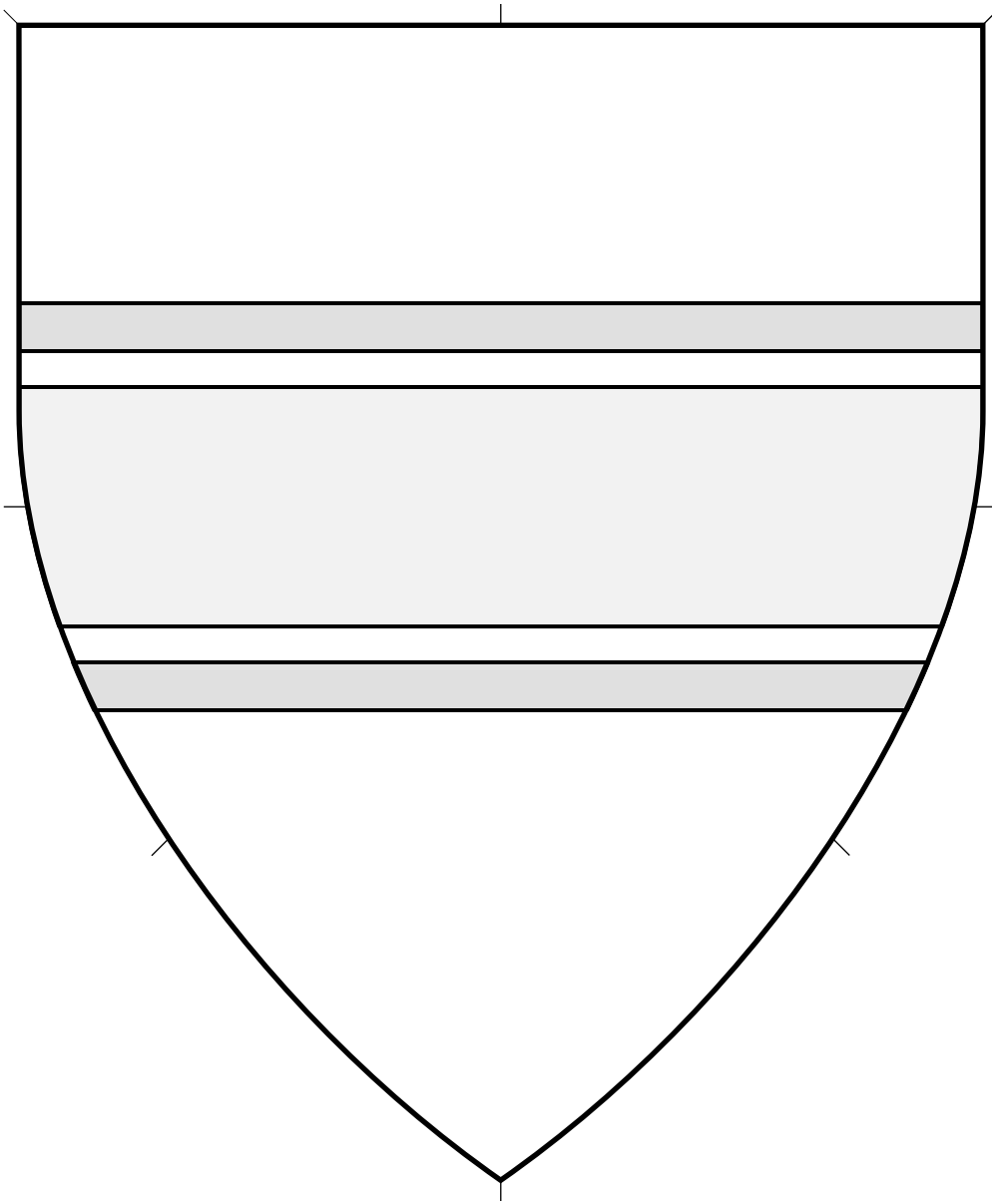

Central ordinary cotised.

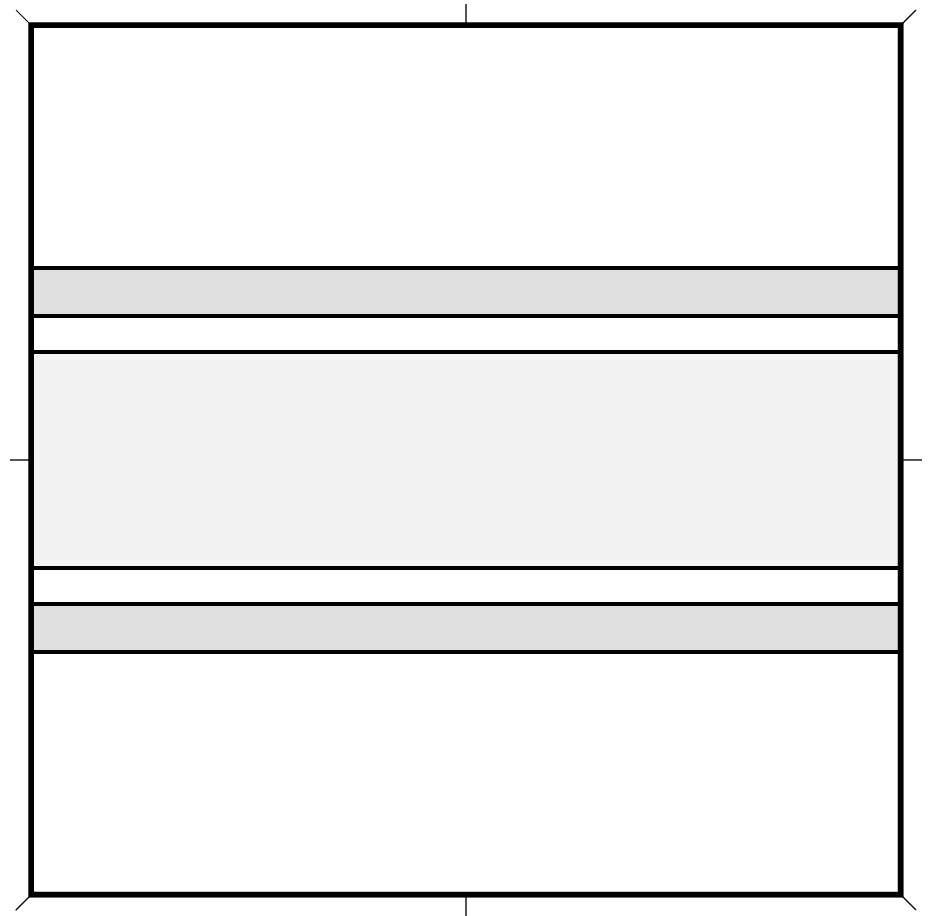

Fess Cotised (1) 4.395

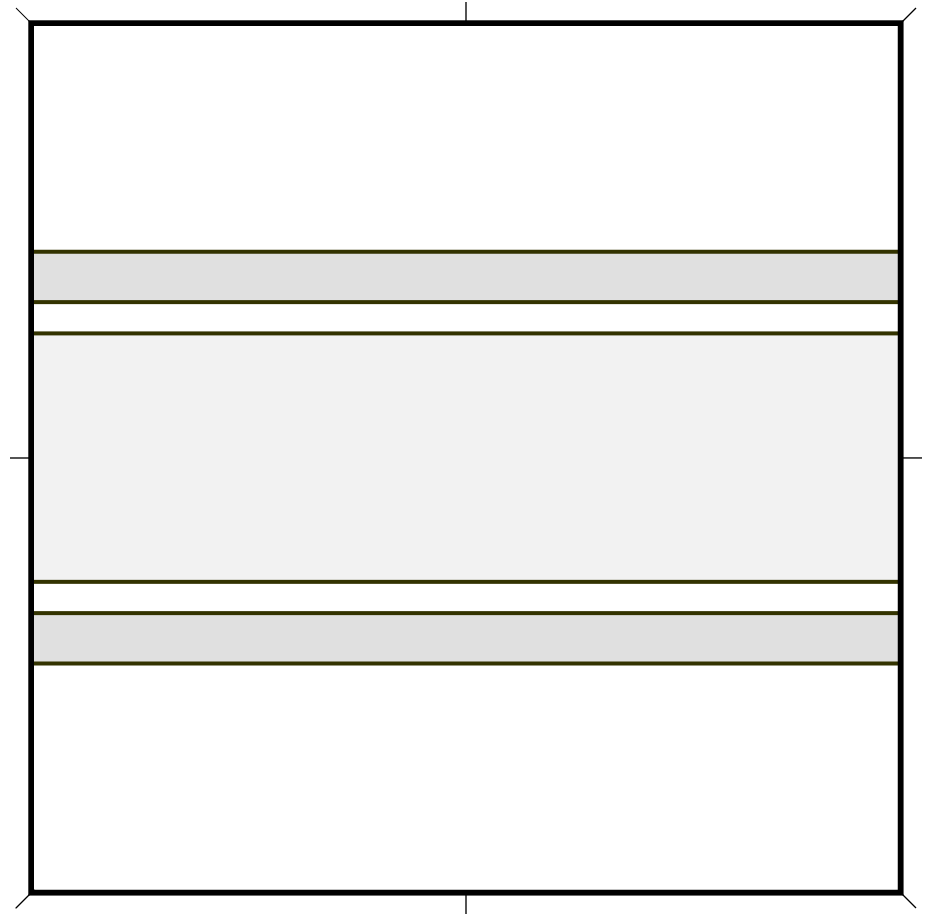
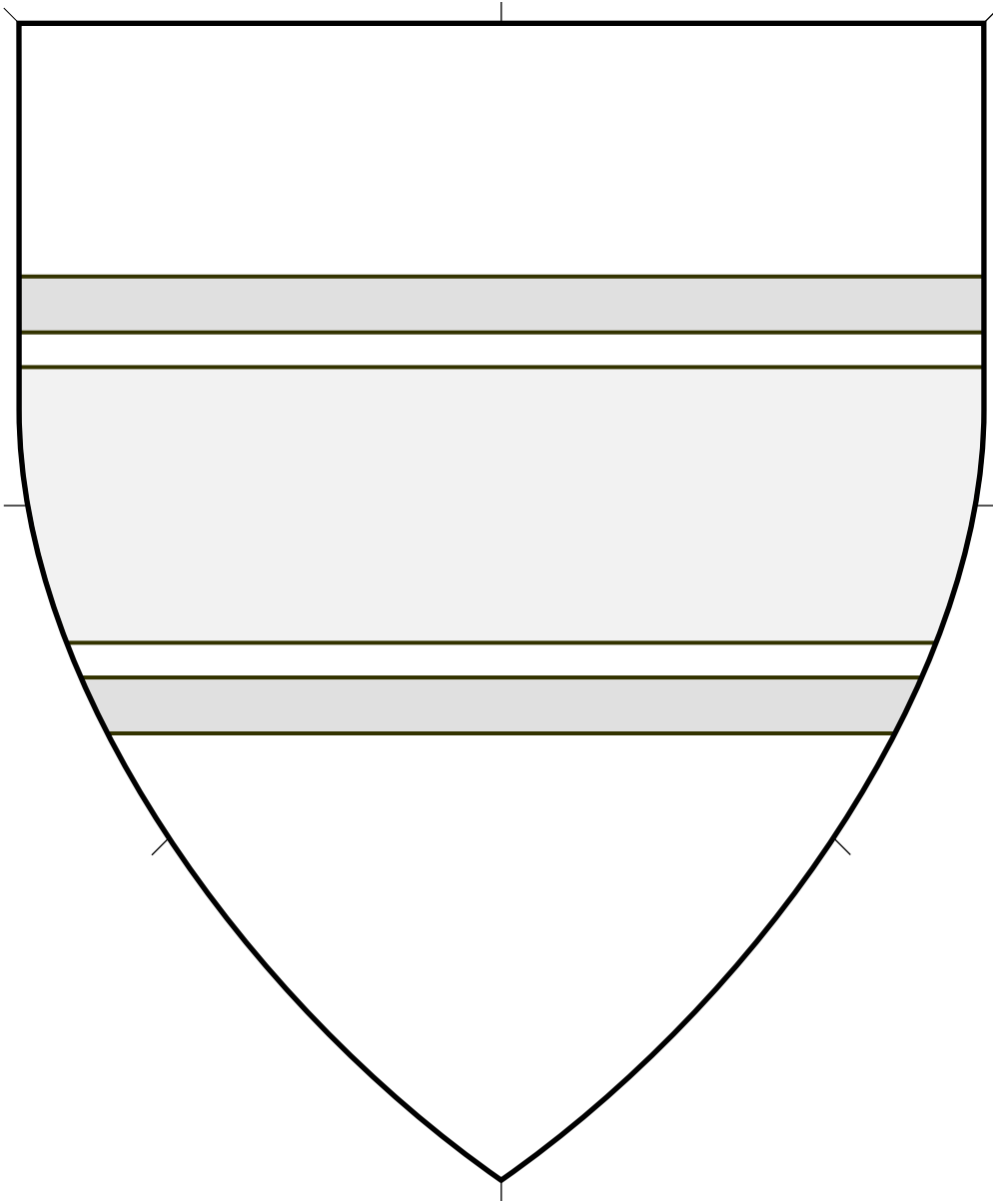

Central ordinary cotised.

Fess Cotised (2) 4.396

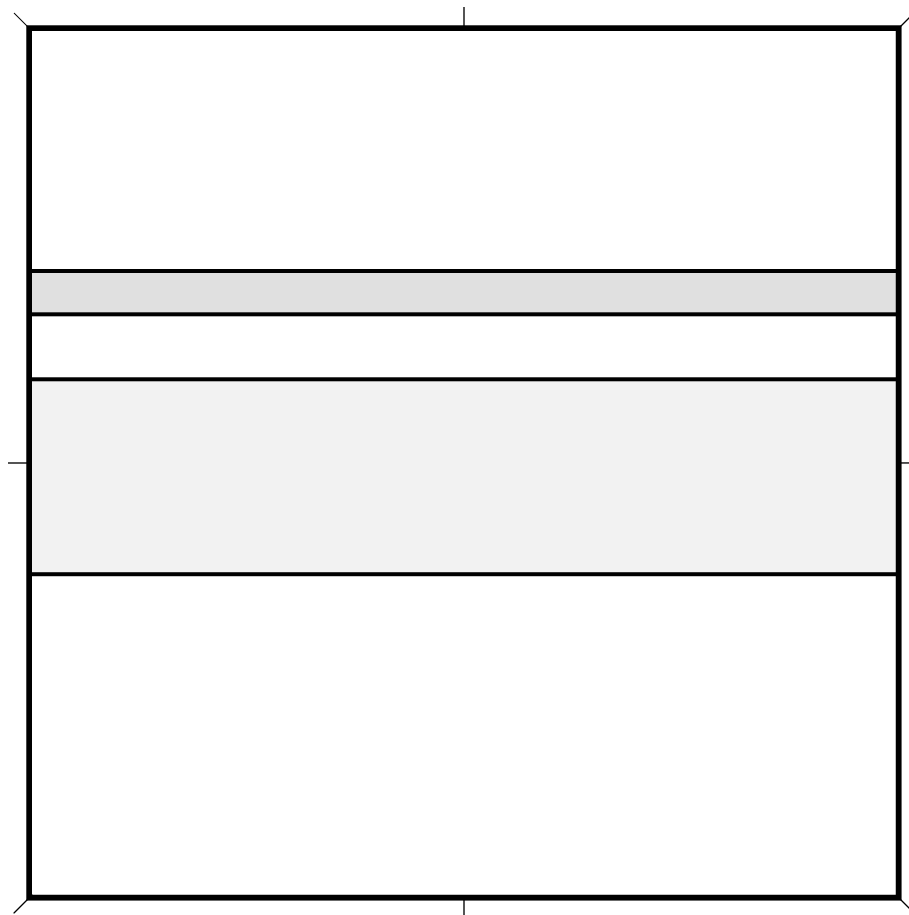
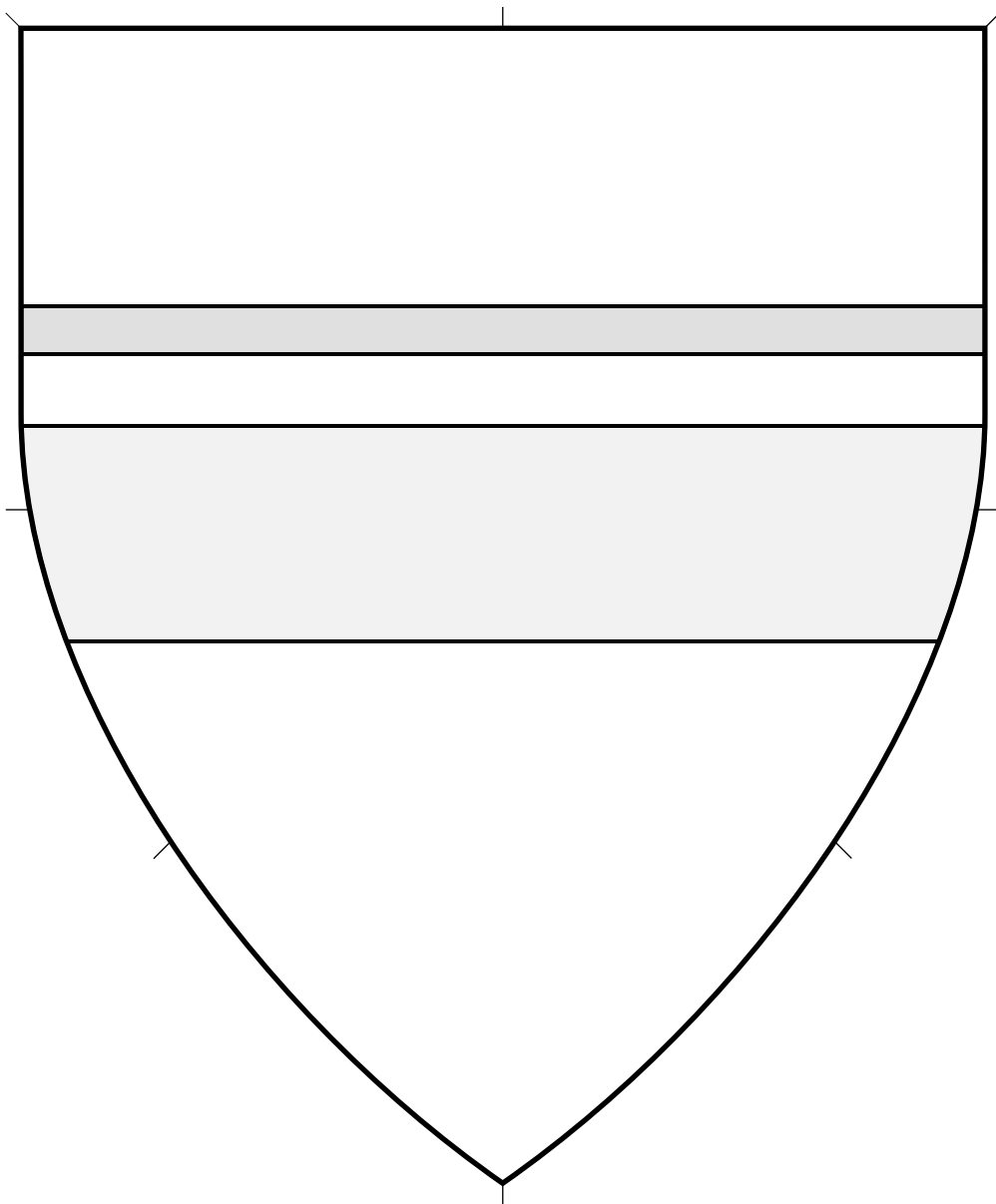

Central ordinary cotised.

Source: BnF MS Allemand 304.
Artist unknown. (Page 224v.)

Fess Cotised to Chief 4.397

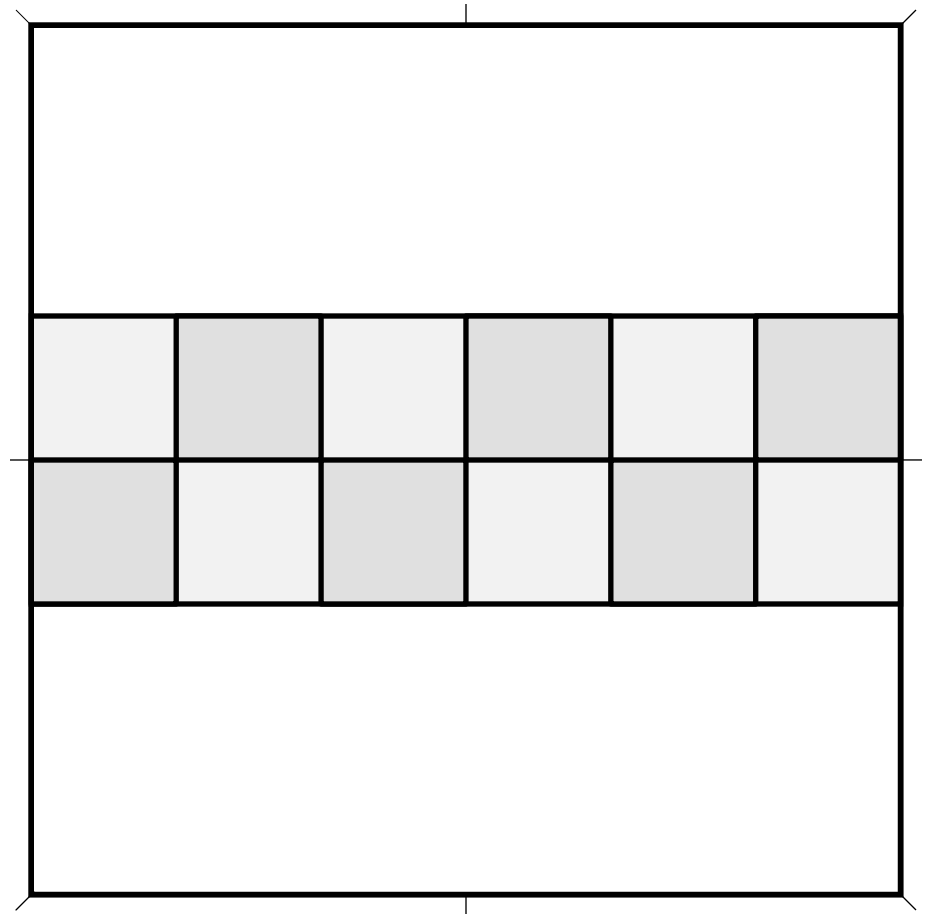
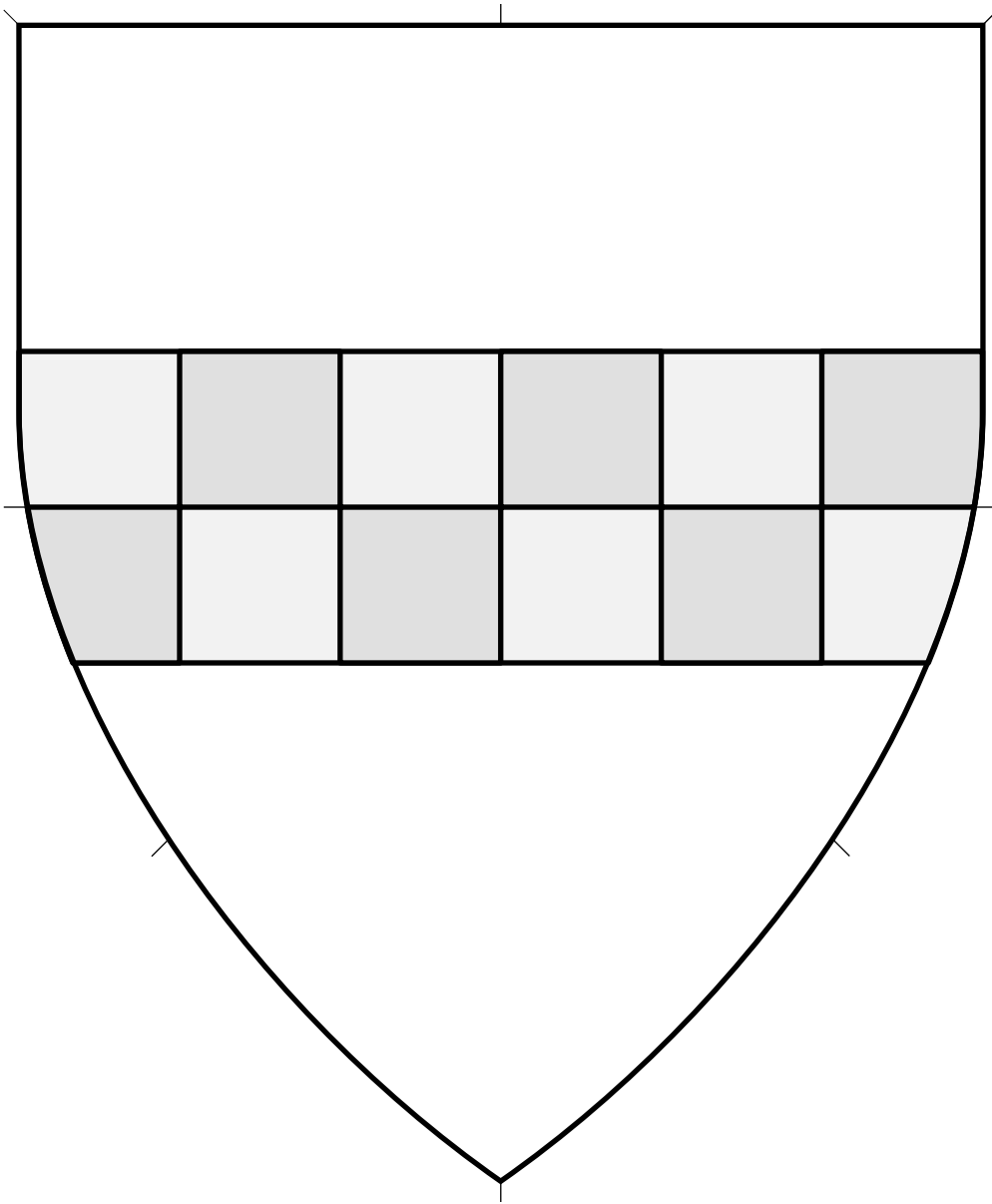

Central ordinary. Two contrasting tinctures.

Fess Counter-compony (1) 4.398

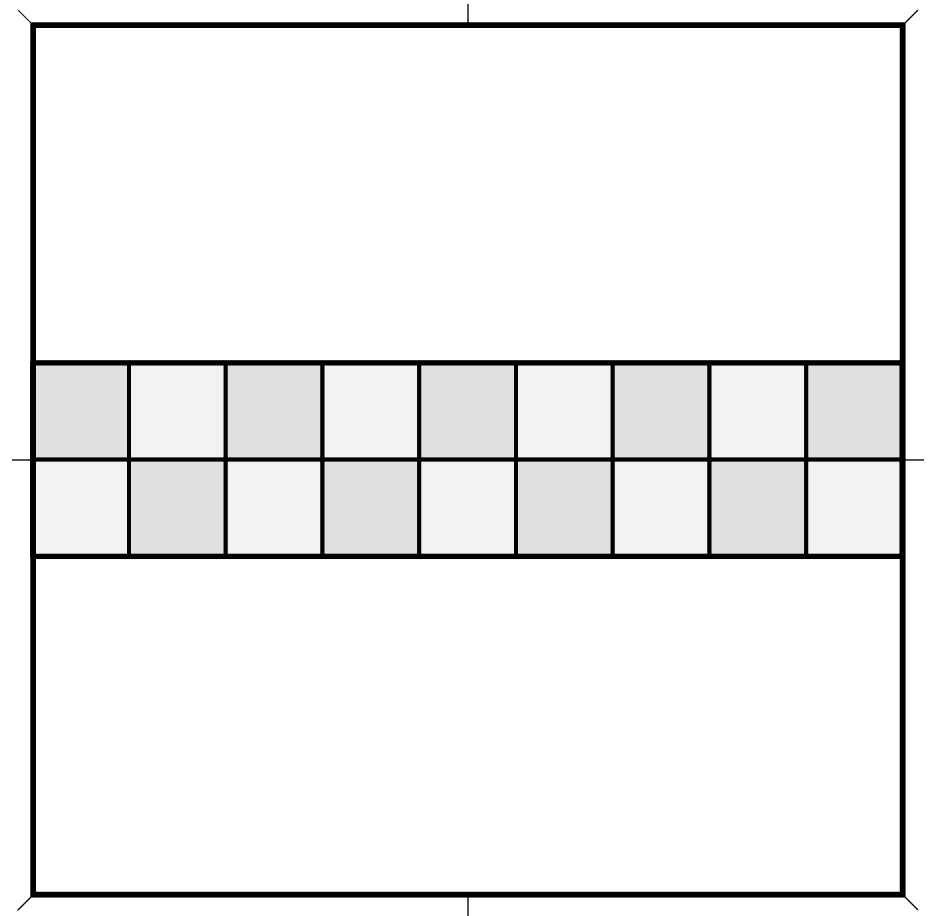
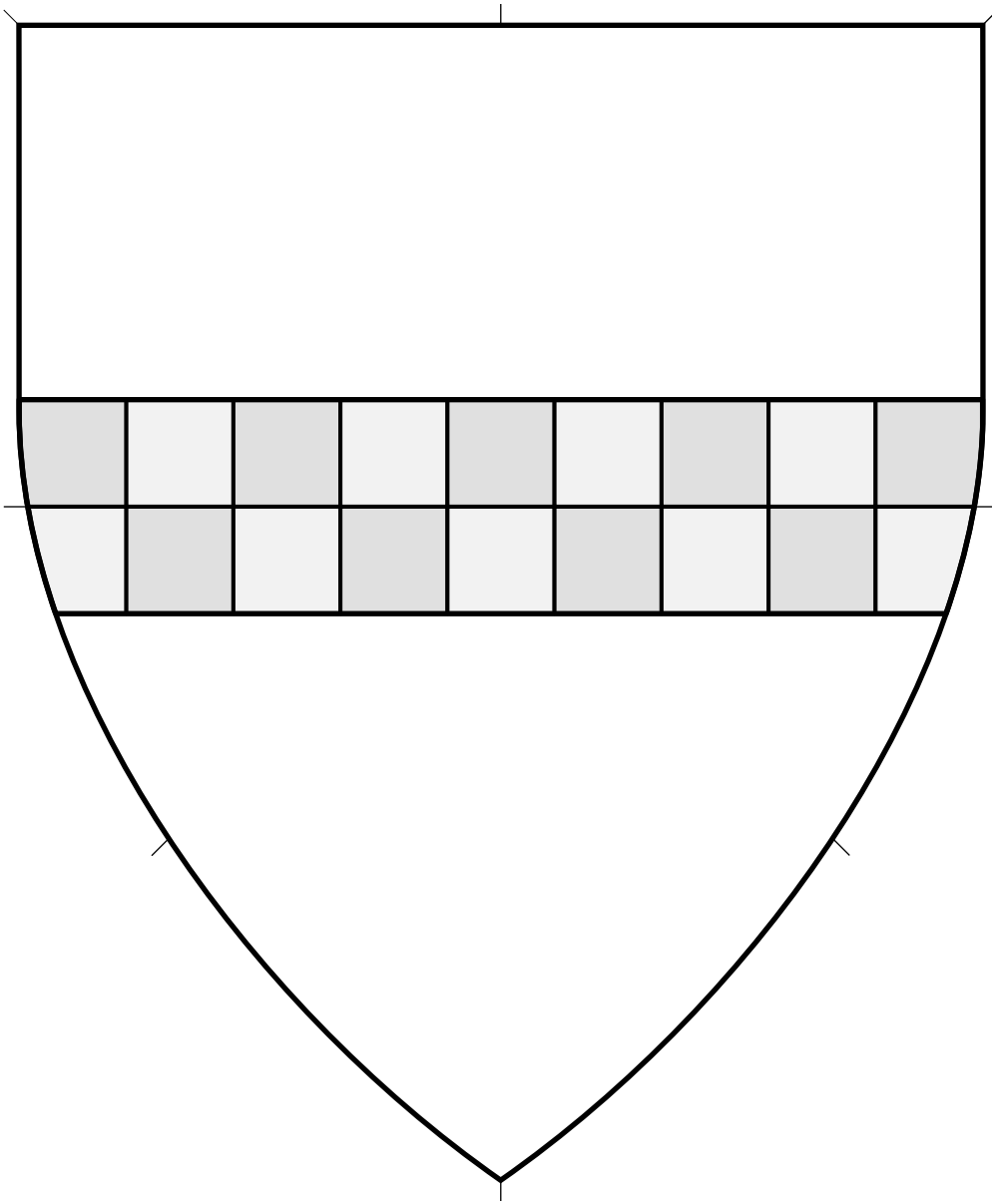

Central ordinary. Two contrasting tinctures.
Source: Thomas Jenyn's Book. Artist unknown. (Folio 27v.)

Fess Counter-compony (2) 4.399

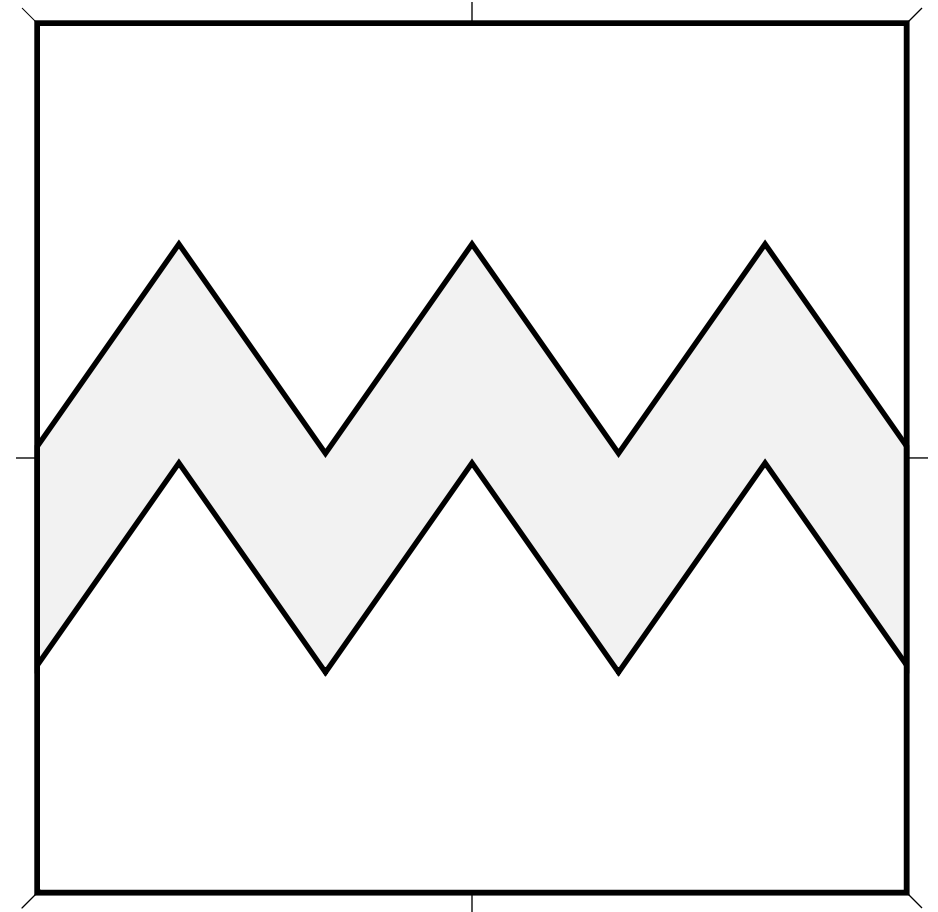
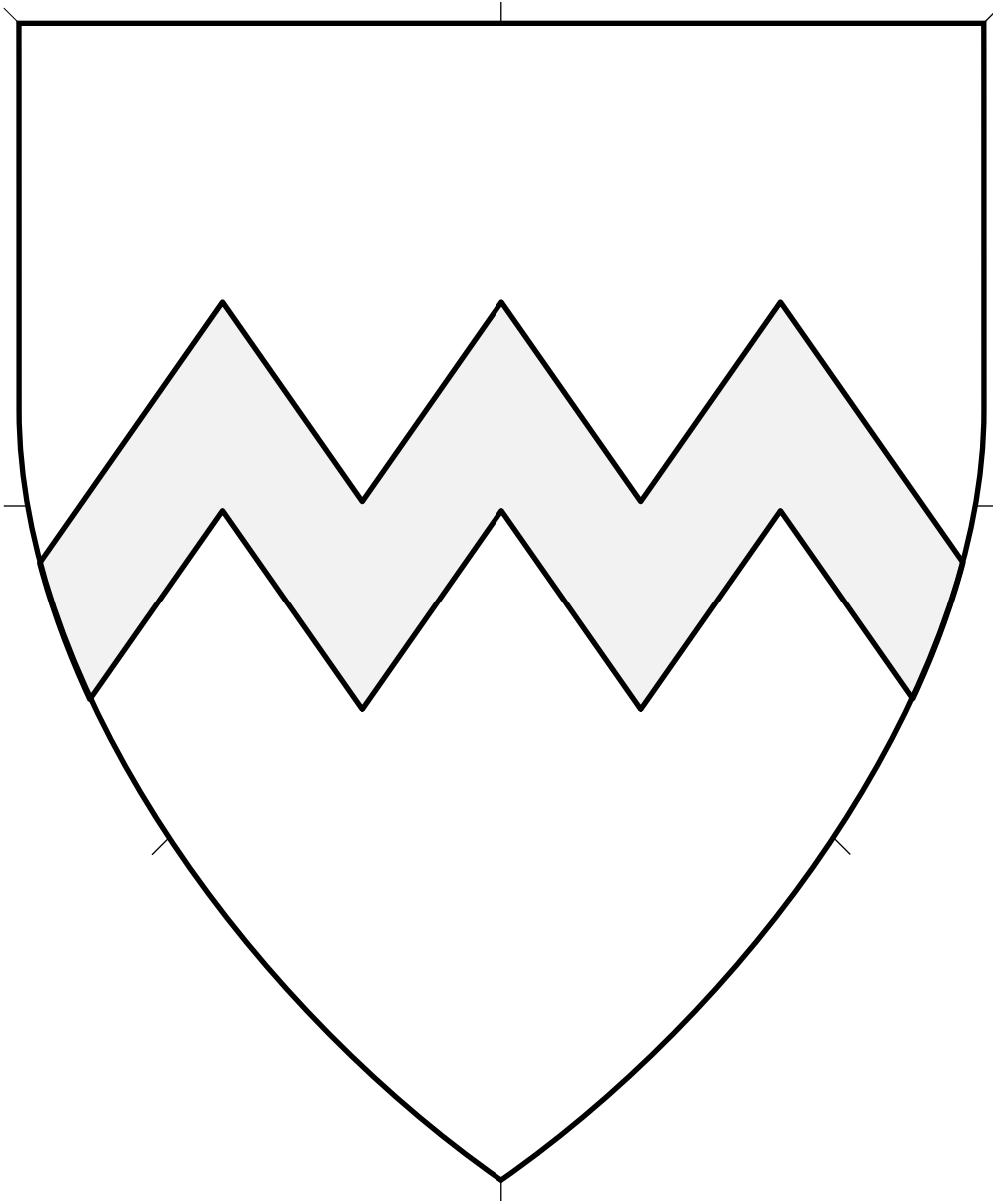

Central ordinary. A fess indented.

Fess Dancetty, or Dance (1) 4.400

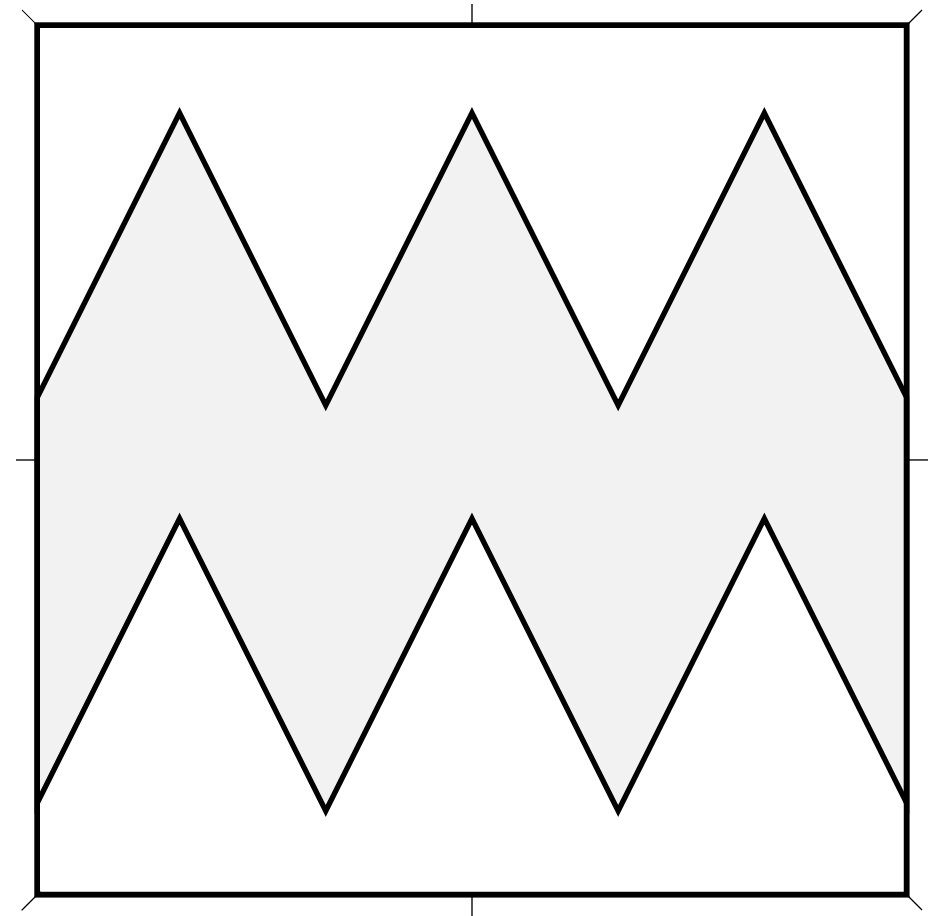
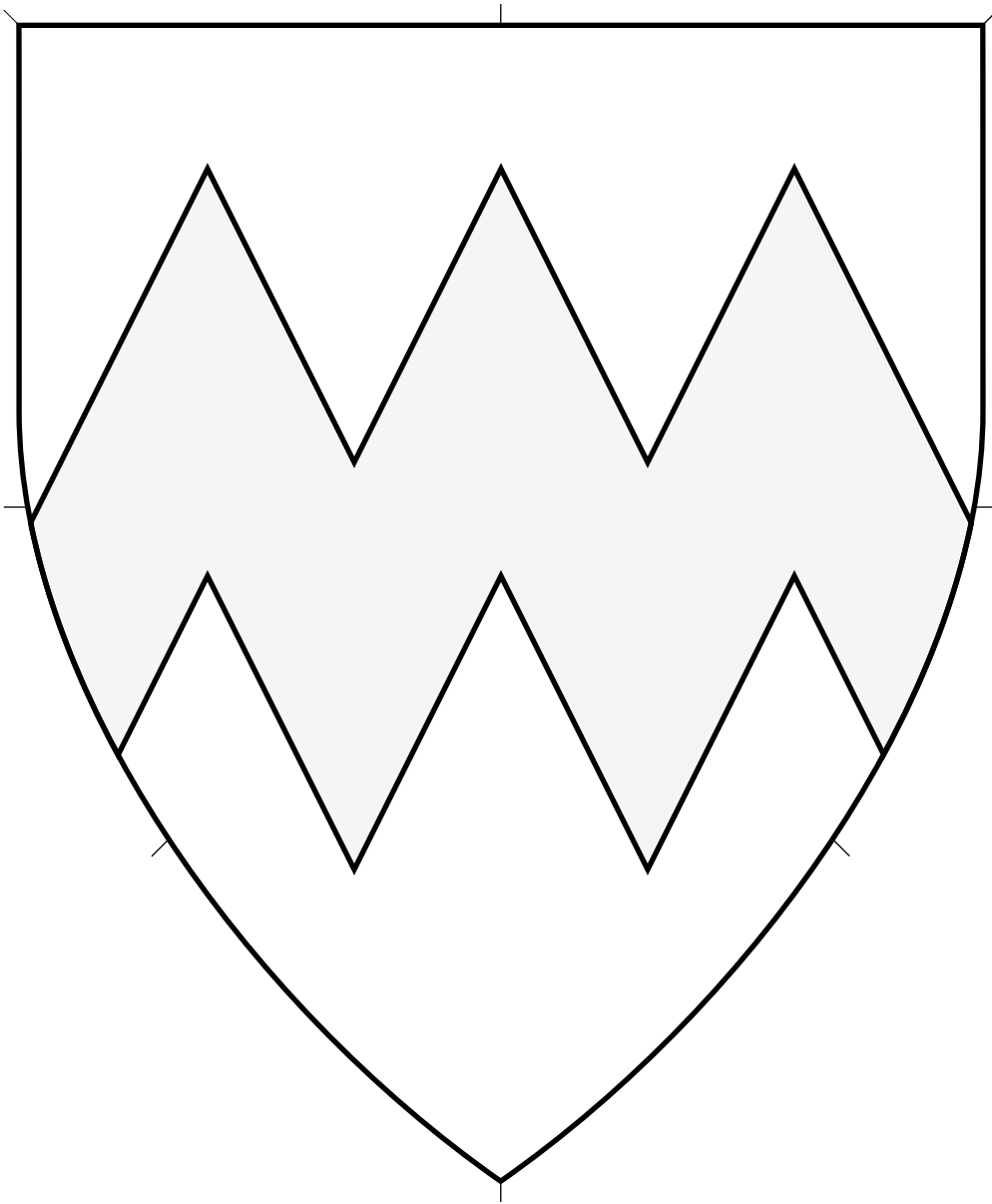

Central ordinary. A fess indented.

Source: Siebmacher's Wappenbuch of 1605. Artist: Johann Siebmacher. (Arms of vom Ulm, page 199.)

Fess Dancetty, or Dance (2) 4.401

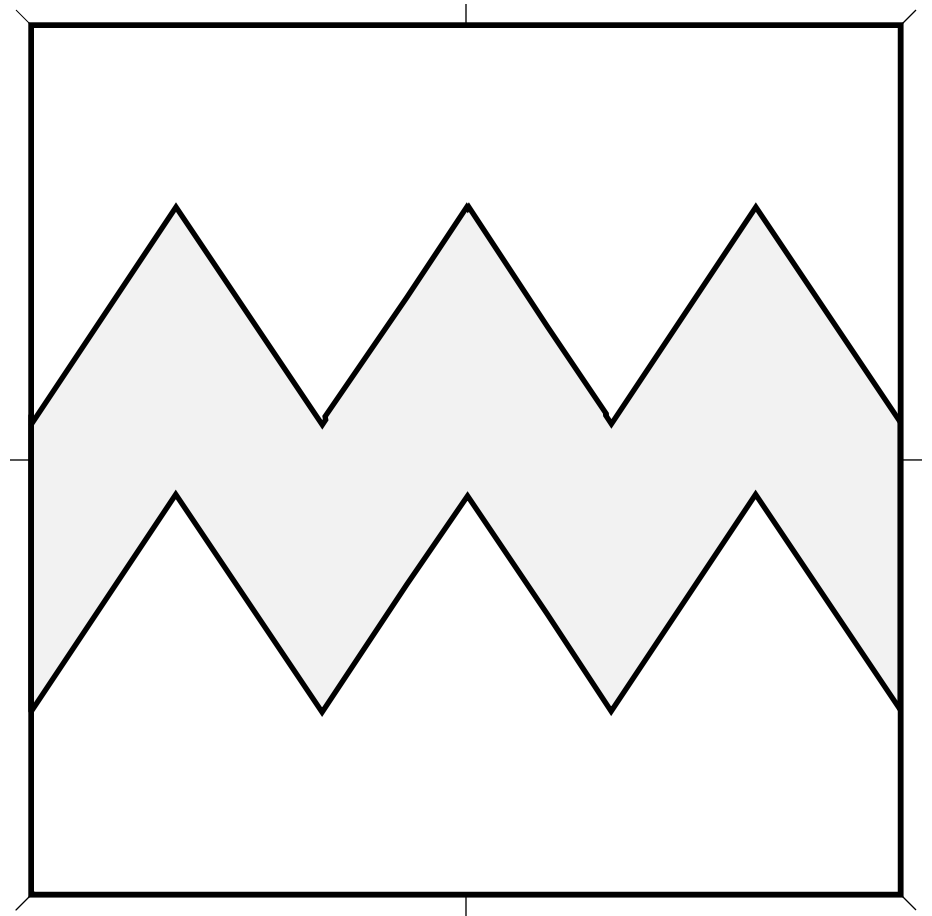
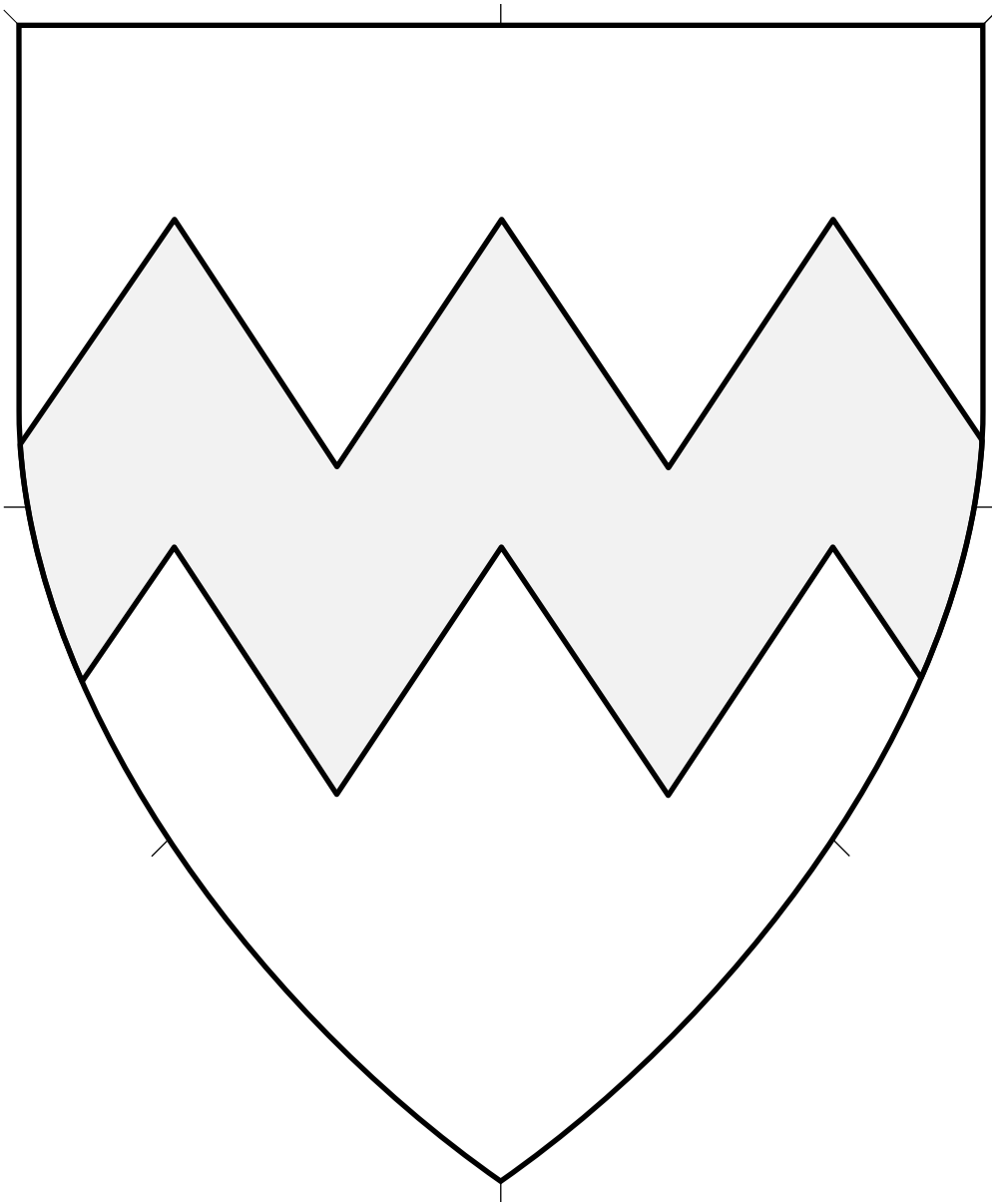

Central ordinary.

Source: Viking Answer Lady SVG Images For Heraldry. Artist: Gunnvôr silfrhárr. Adapted by Mathghamhain Ua Ruadháin.

Fess Dancetty, or Dance (3) 4.402

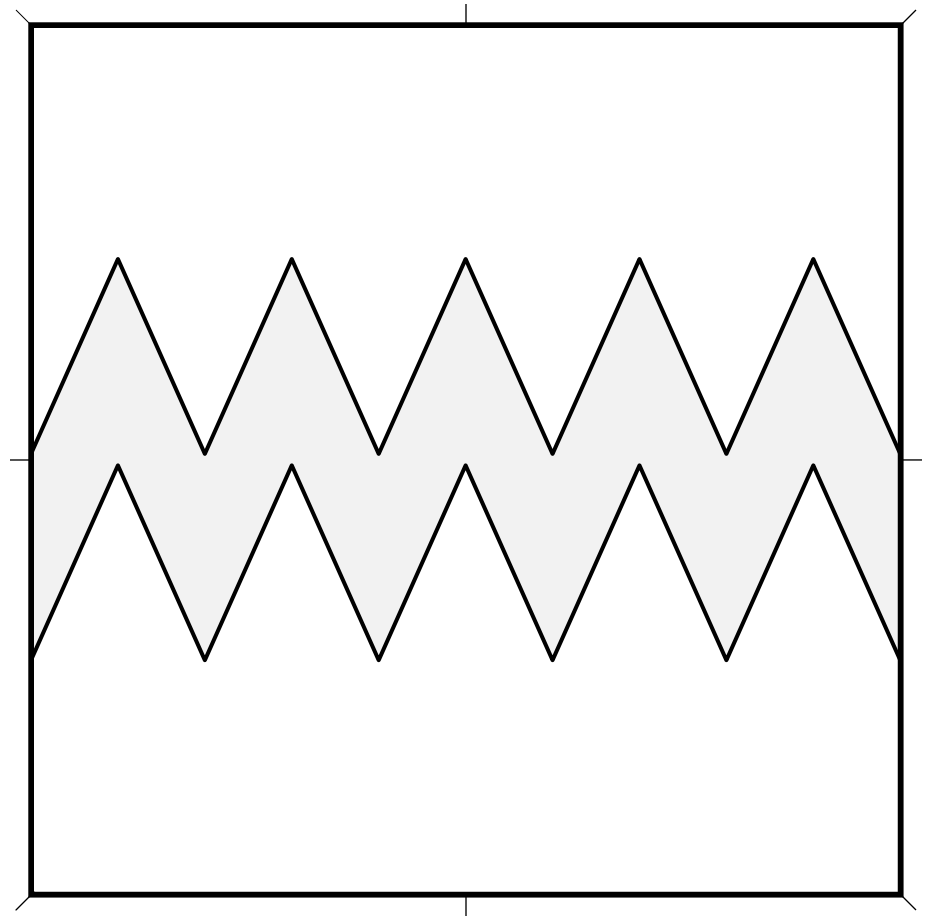
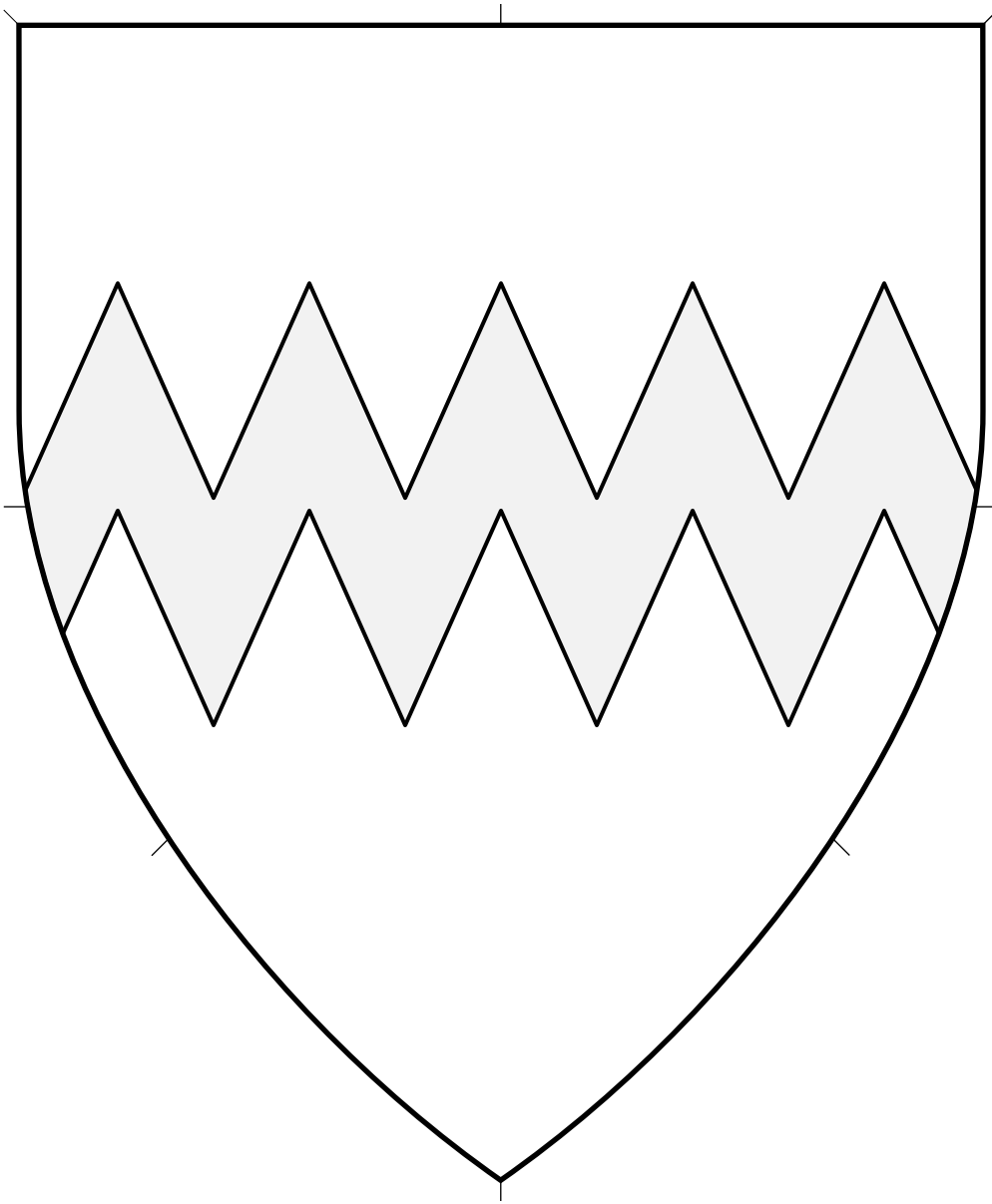

Central ordinary.

Source: Zurich Roll. Artist unknown. (Folio 3v.)

Fess Dancetty, or Dance (4) • 4.403

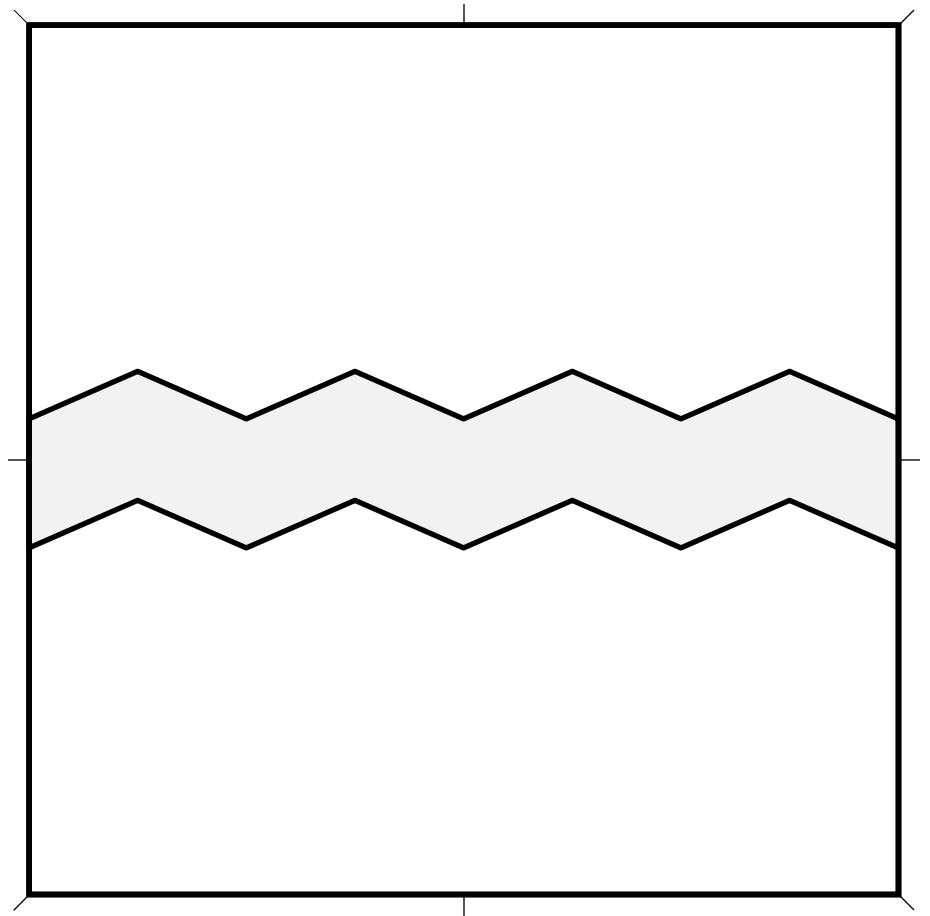
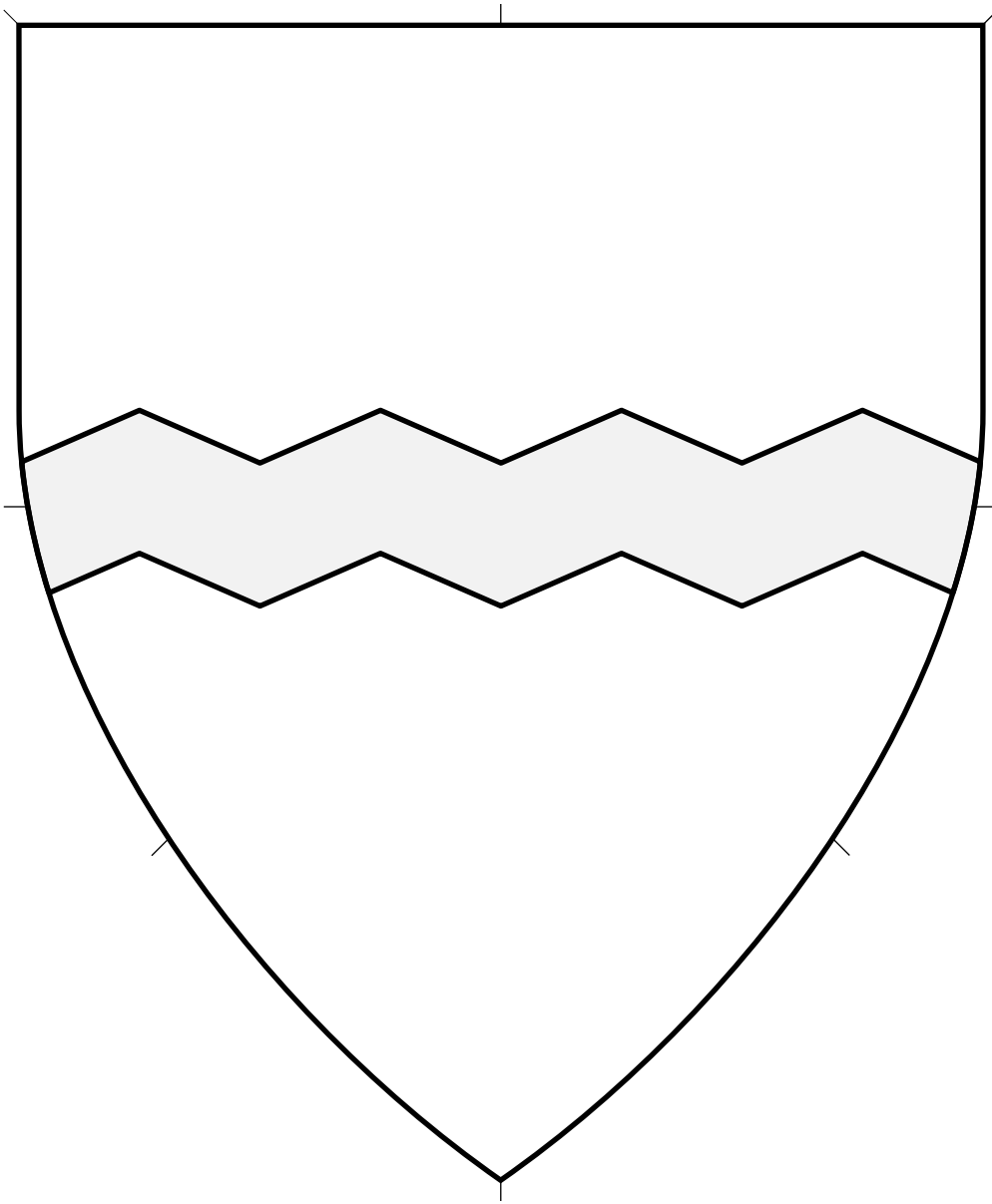

Central ordinary.

Source: Armorial General d'Europe.

Artist: Victor Rolland and Henri Rolland.

Fess Dancetty, or Dance (5) 4.404

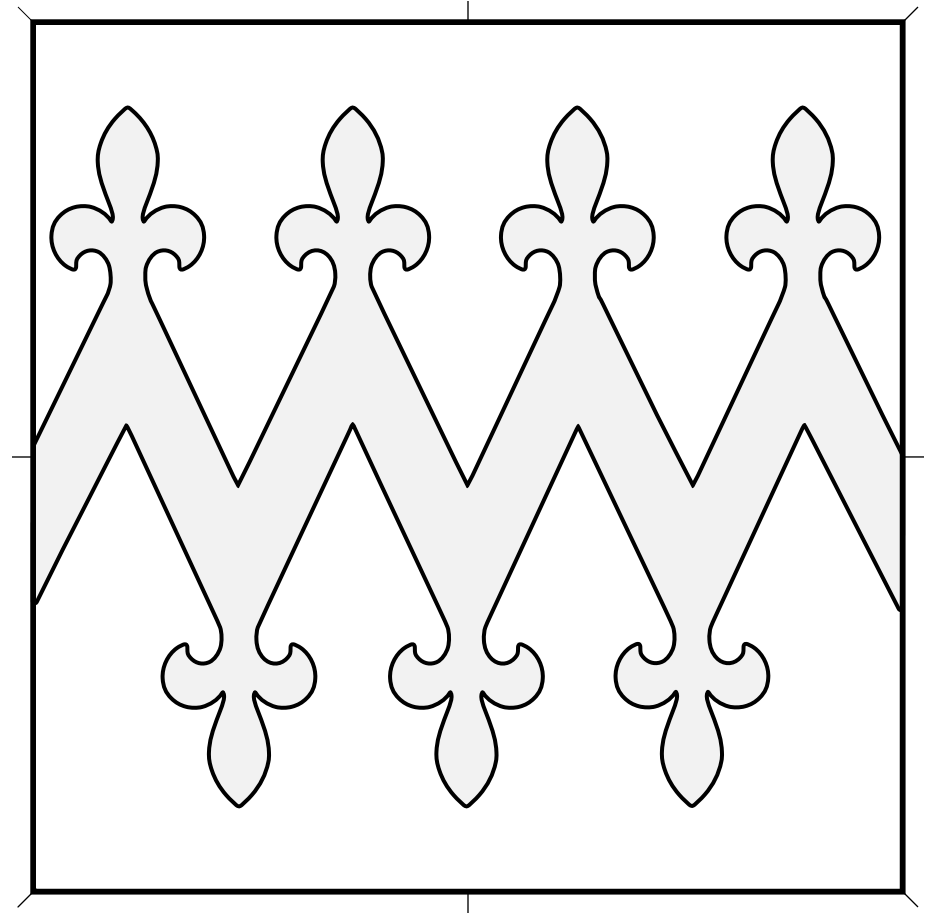
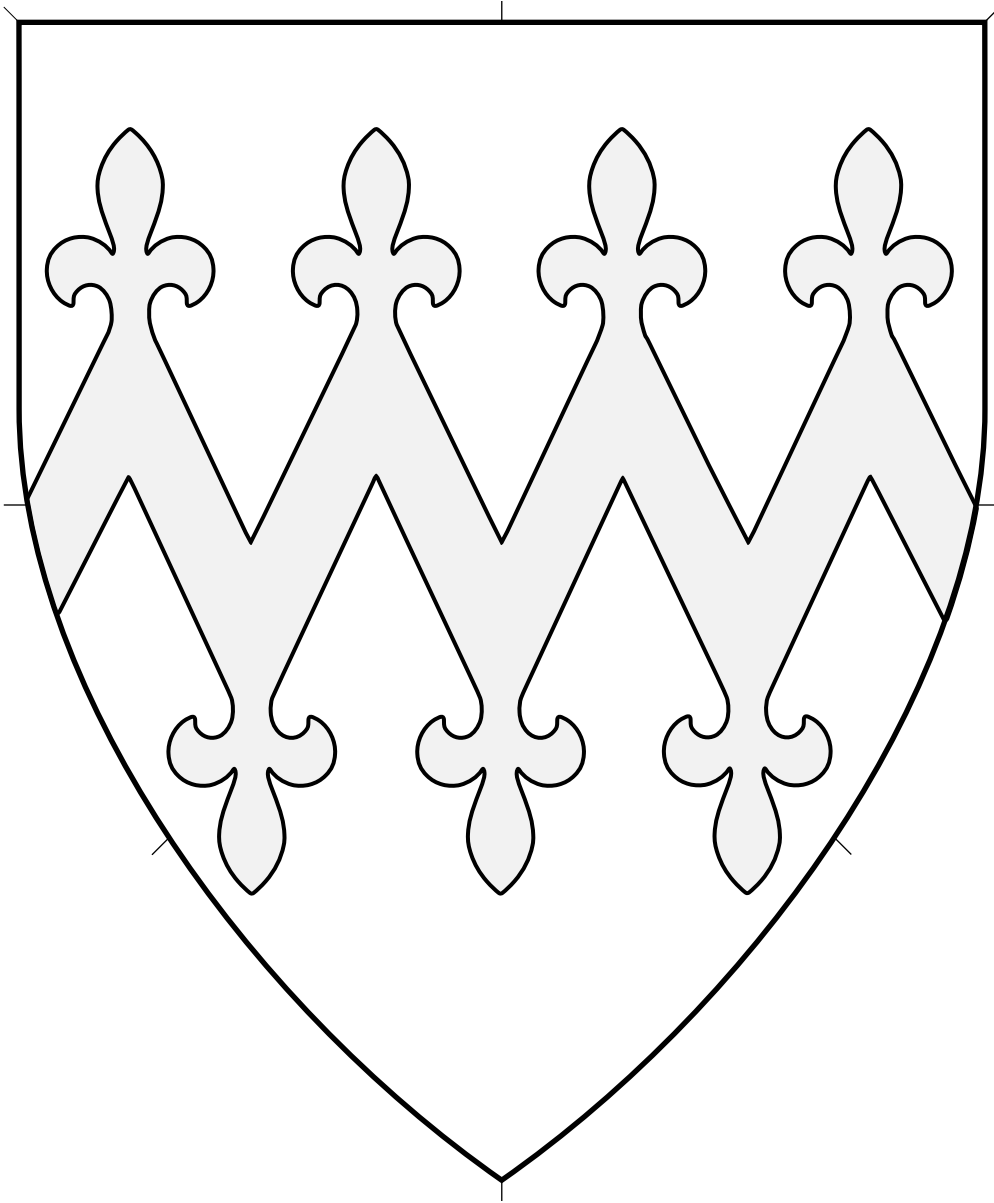

Central ordinary. A fess indented with fleurs-de-lys added to each point.

Artist: Ajir Tsagaan. Adapted by Mathghamhain Ua Ruadháin.

Fess Dancetty Flory at the Points (1) 4.405

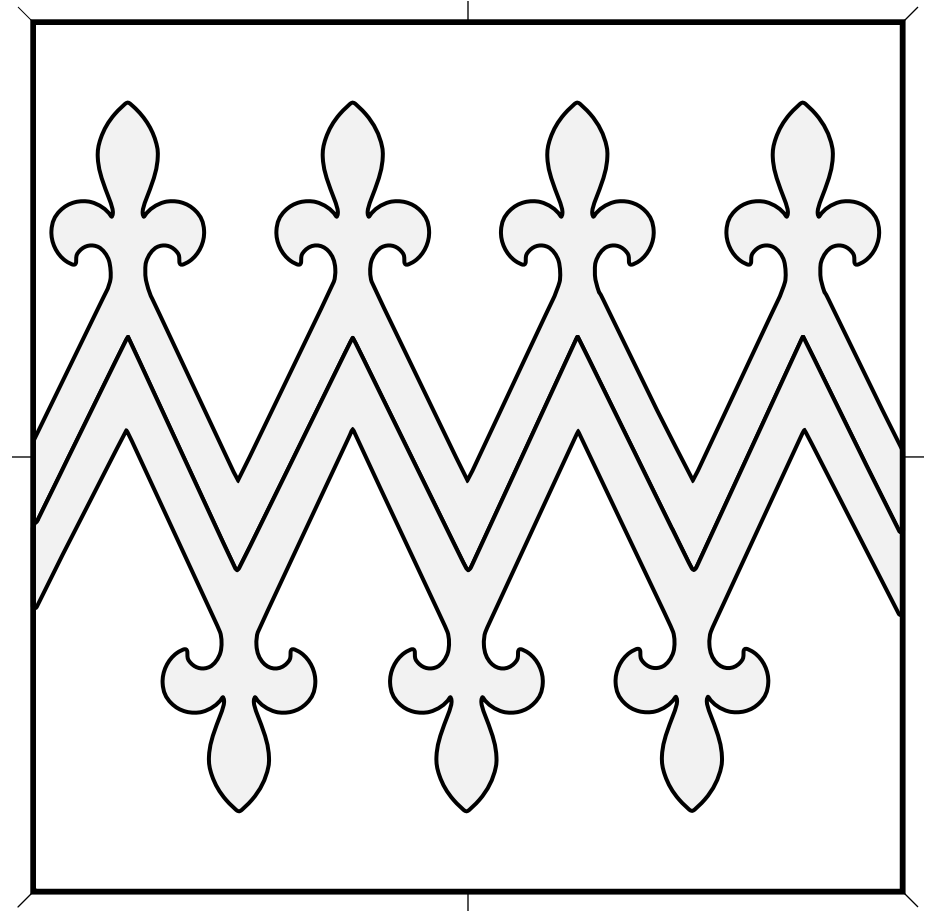
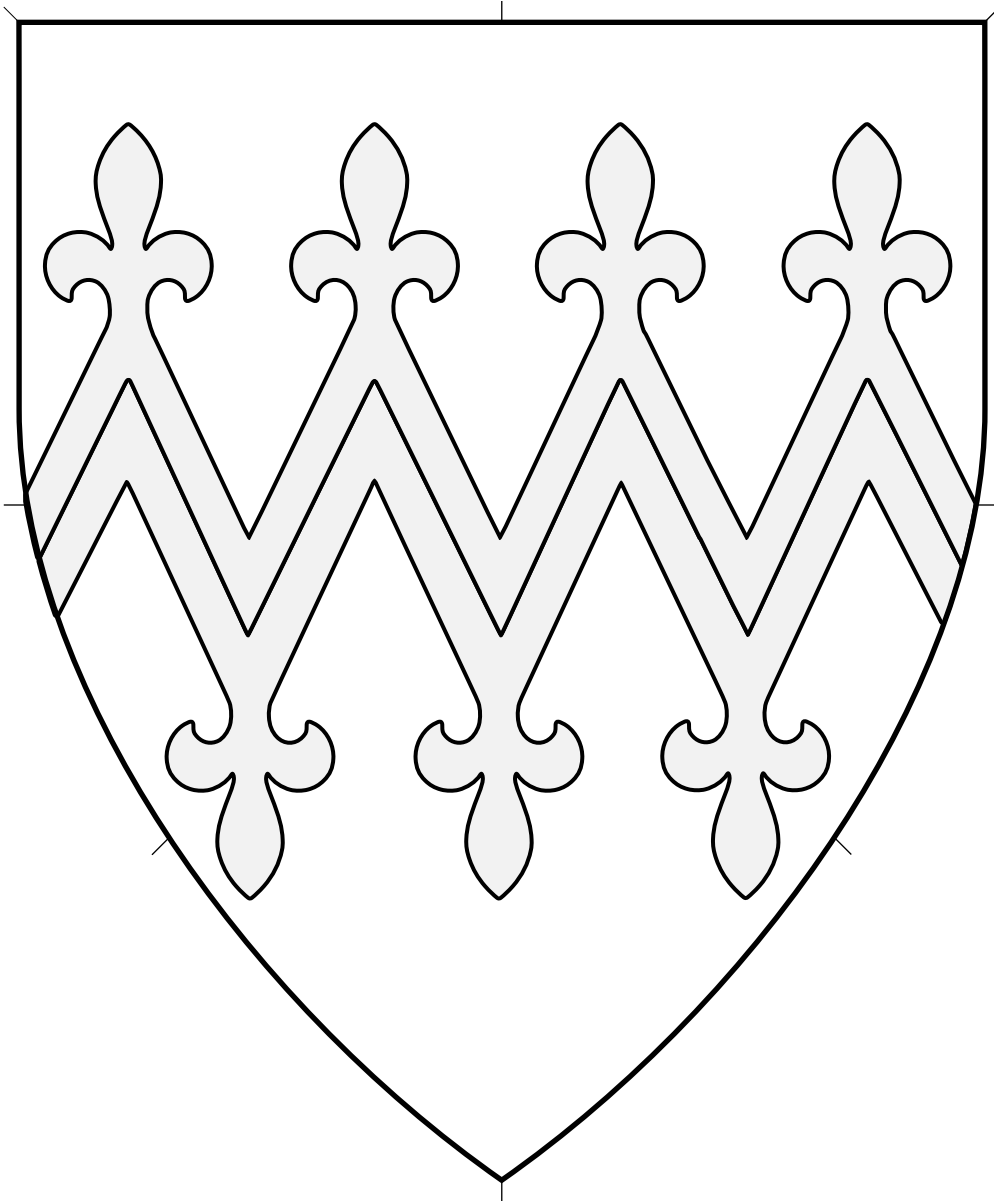

Central ordinary. A fess indented with fleurs-de-lys added to each point.

Artist: Ajir Tsagaan. Adapted by Mathghamhain Ua Ruadháin.

Fess Dancetty Flory at the Points (2) 4.406

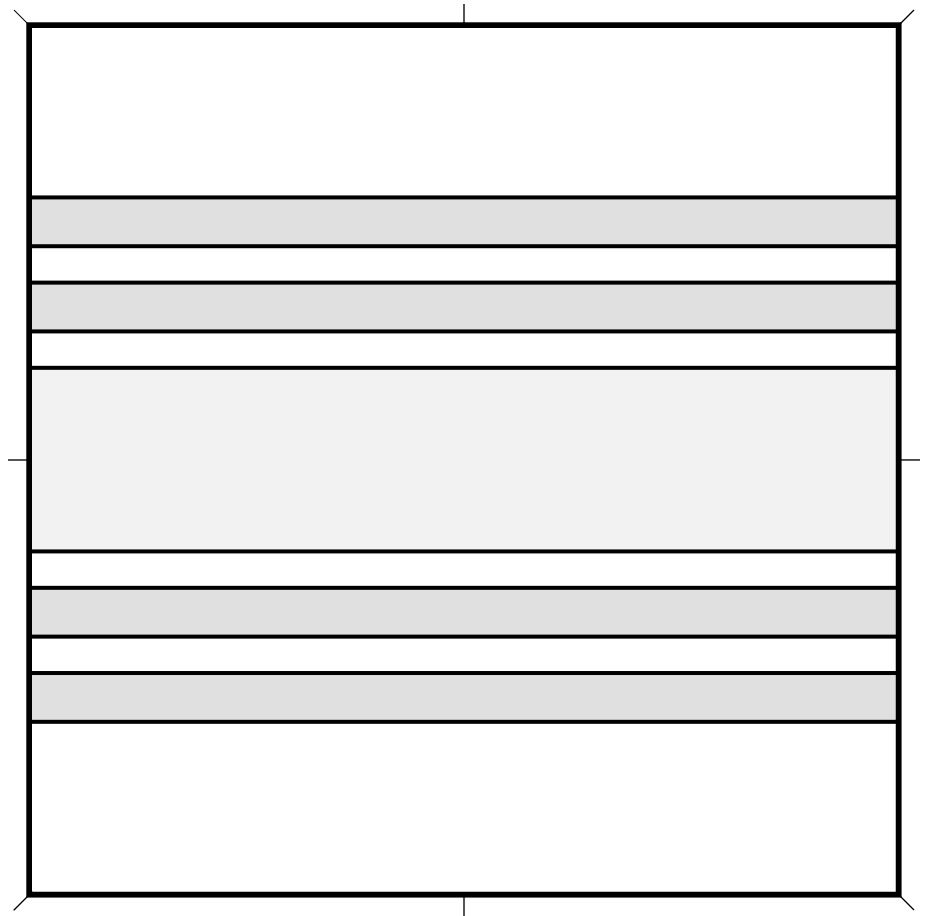
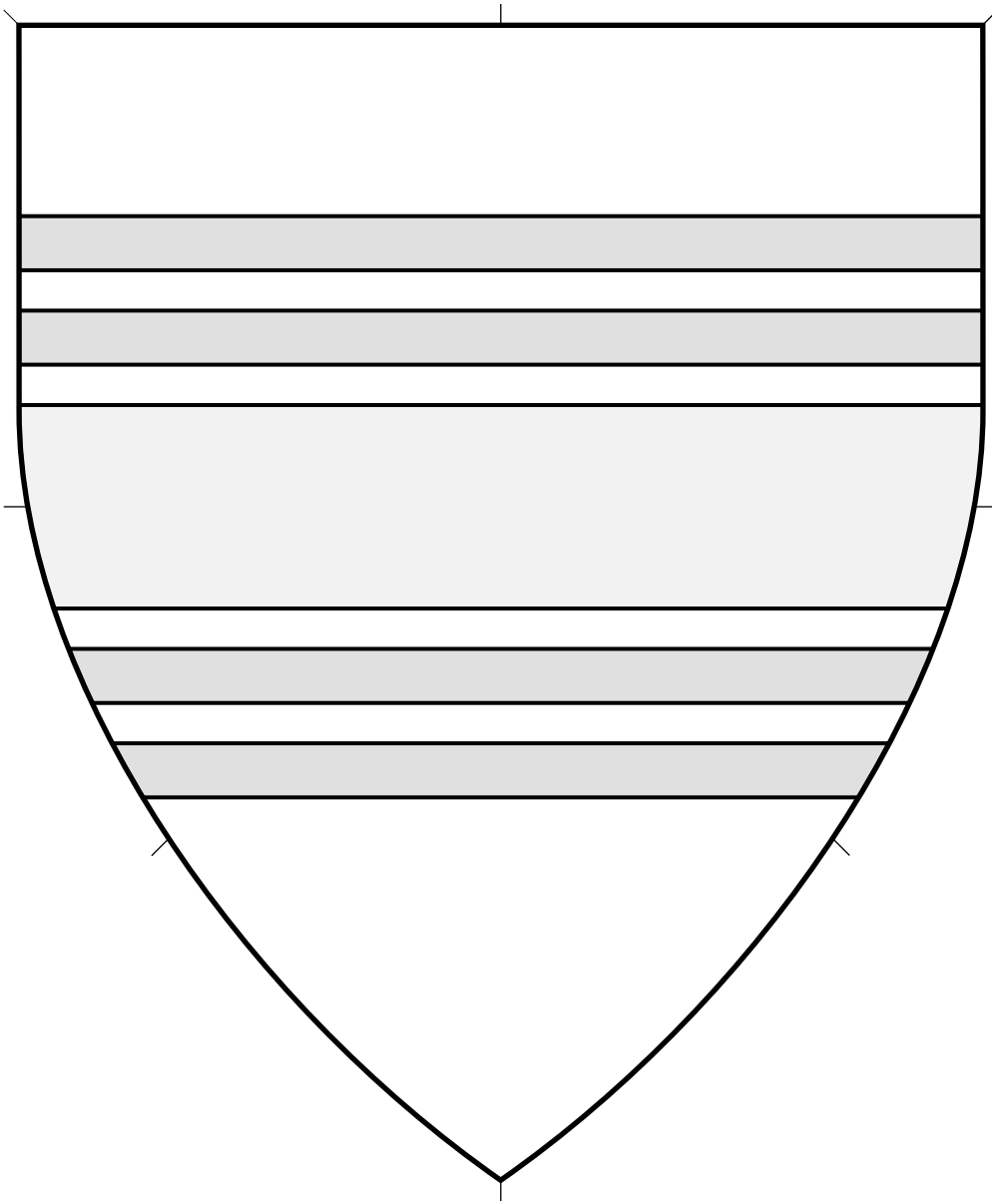

Central ordinary.

Source: Thomas Jenyn's Book. Artist unknown. (Folio 26r.)

Fess Doubly Cotised 4.407

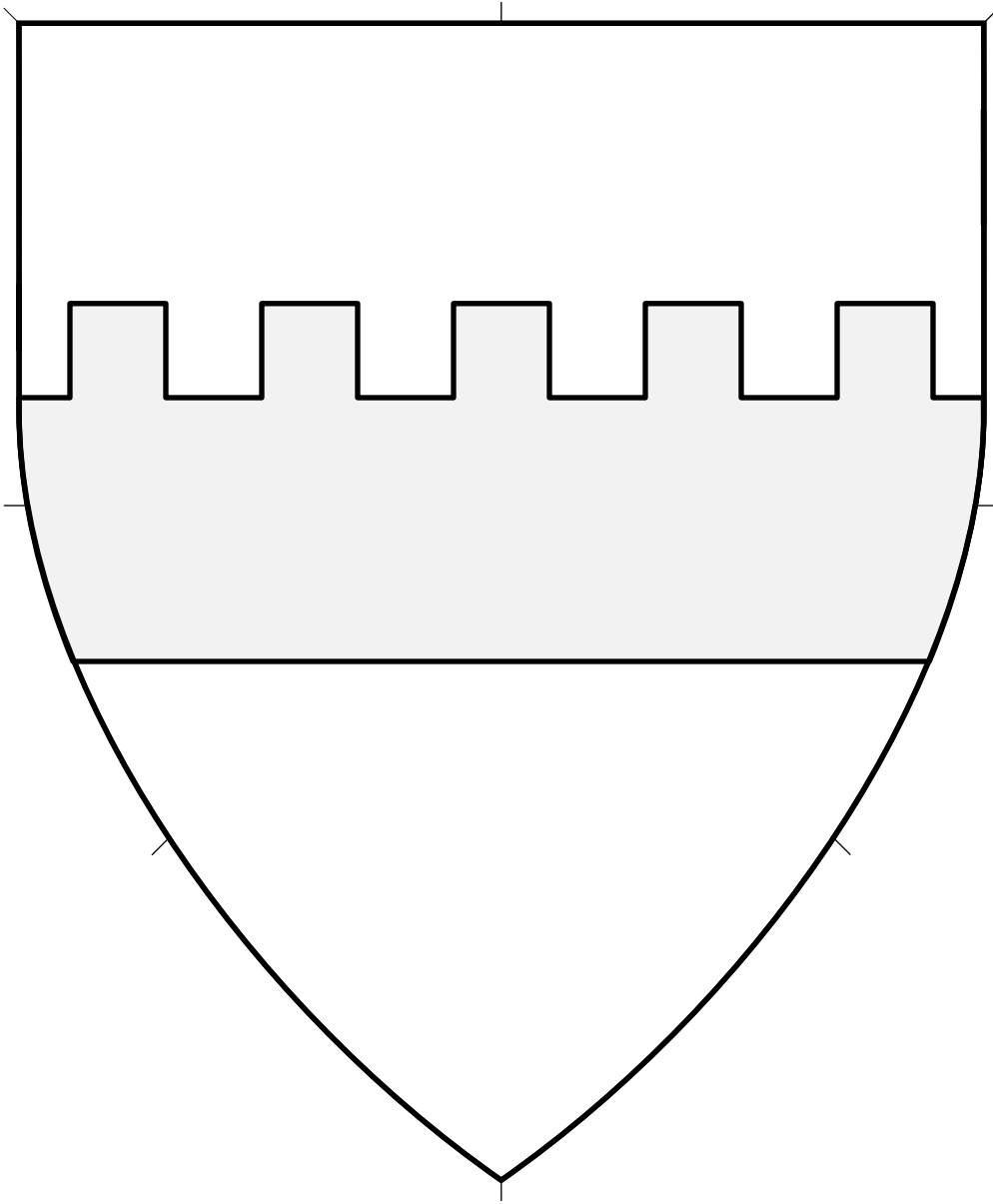

Central ordinary.

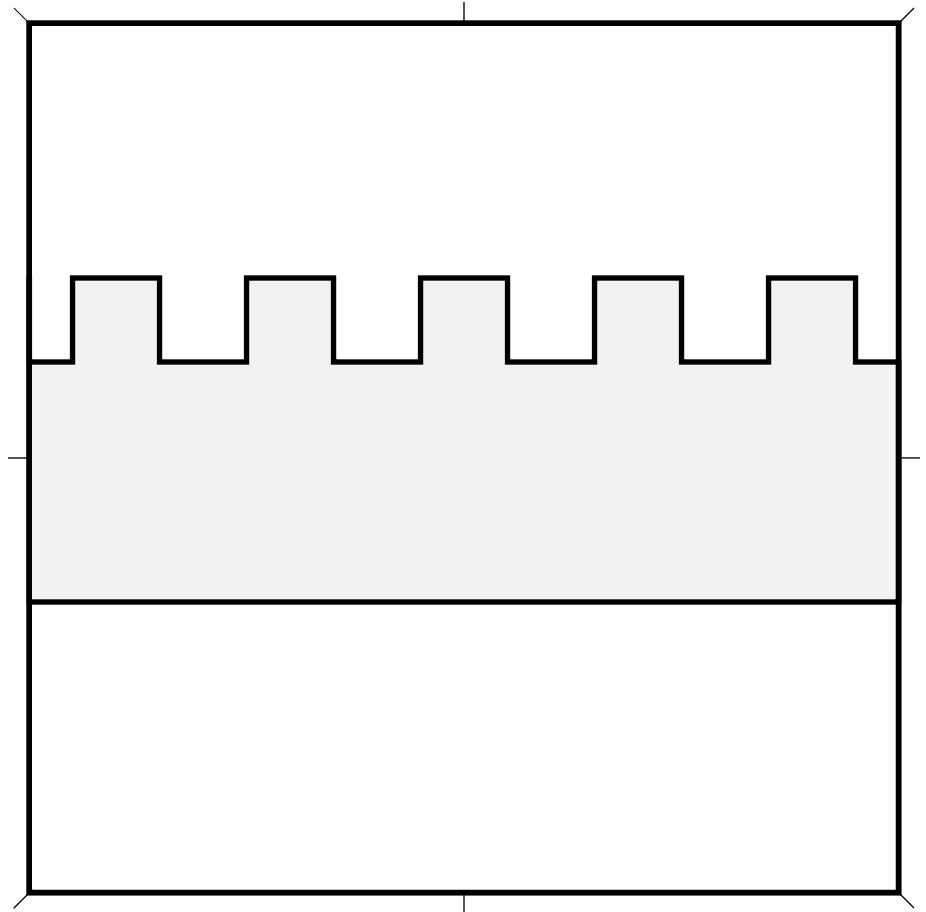

Fess Embattled (1) 4.408

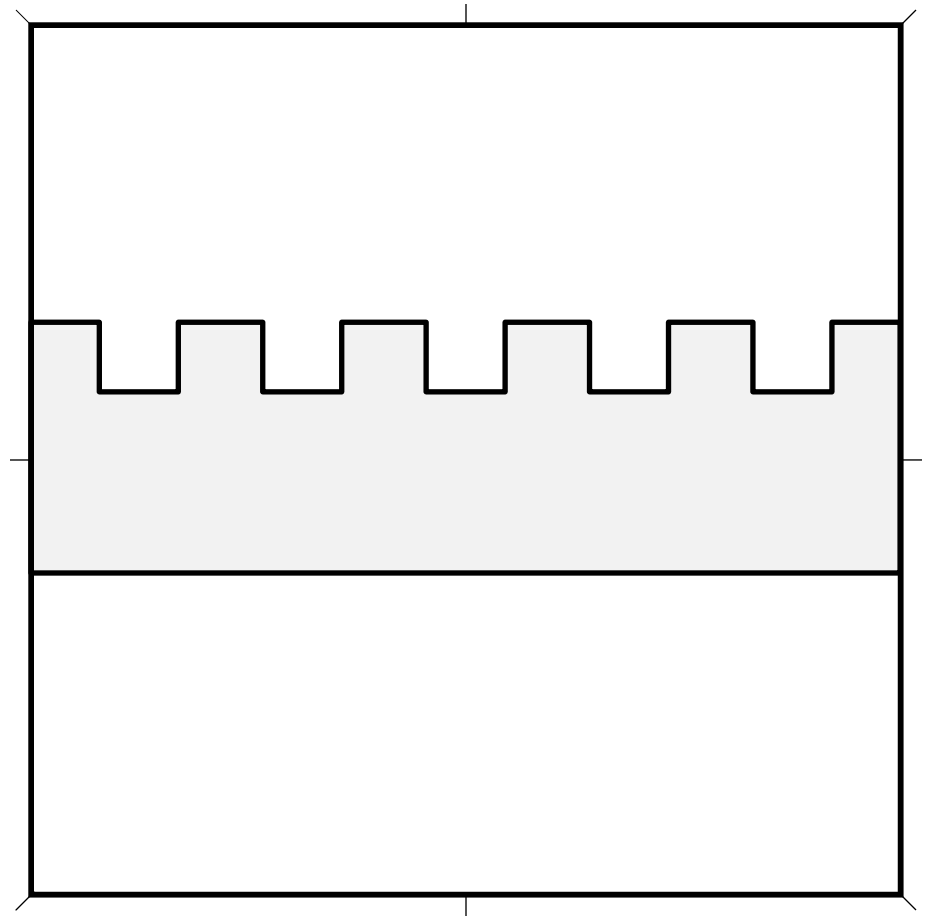
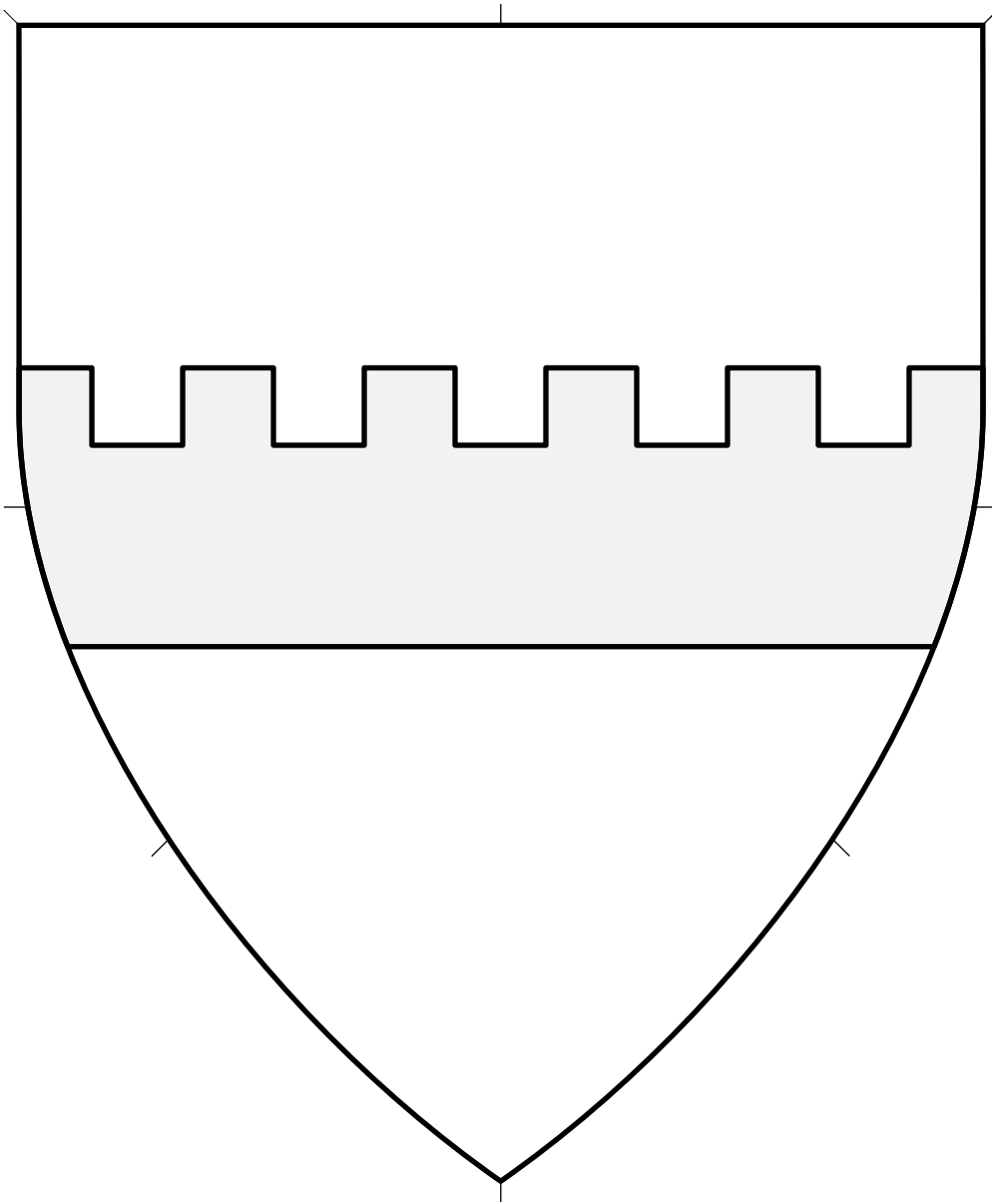

Central ordinary.

Source: Viking Answer Lady SVG Images For Heraldry.
Artist: Gunnvôr silfrhárr. Adapted by Mathghamhain Ua Ruadháin.

Fess Embattled (2) 4.409

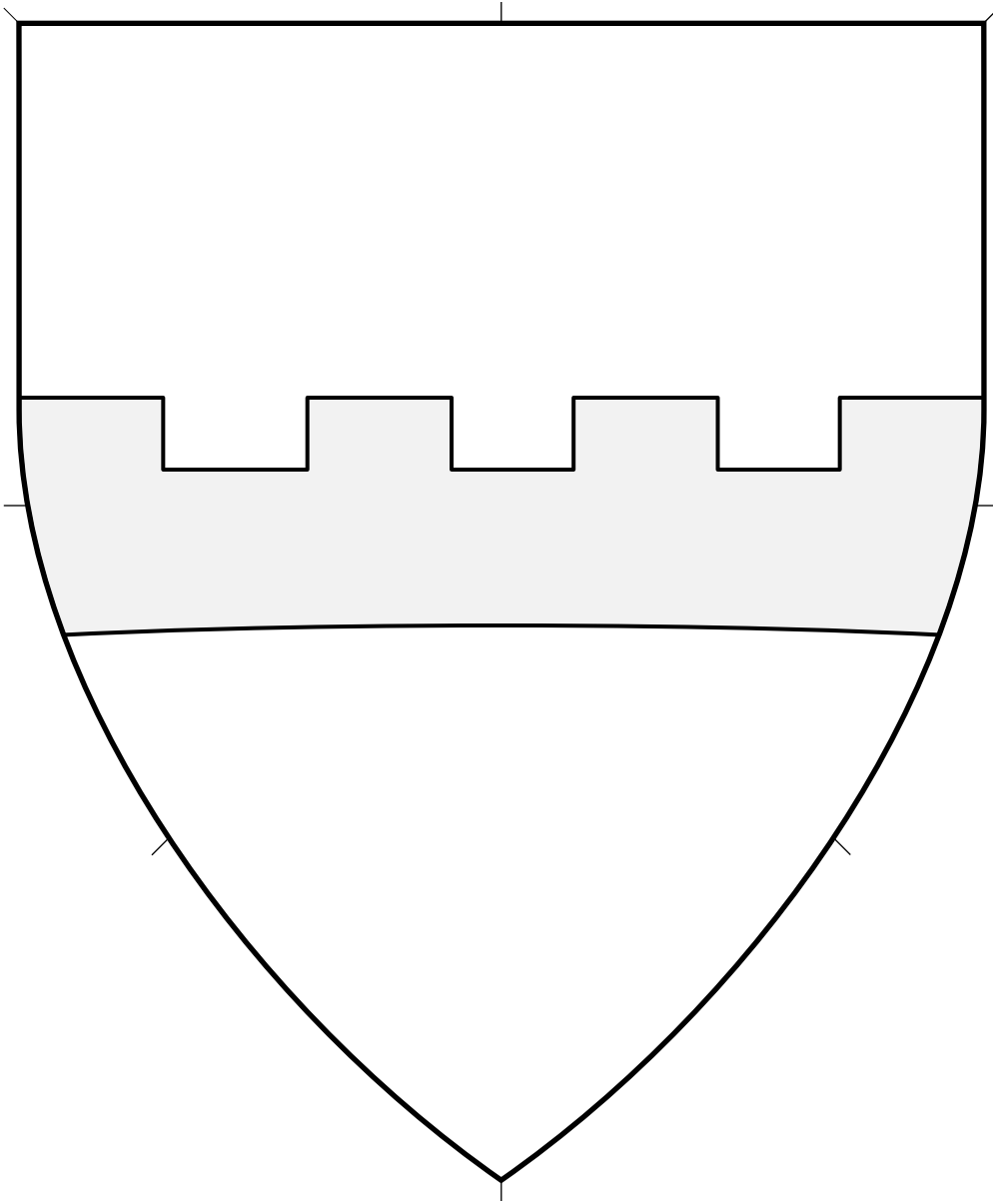

Central ordinary.

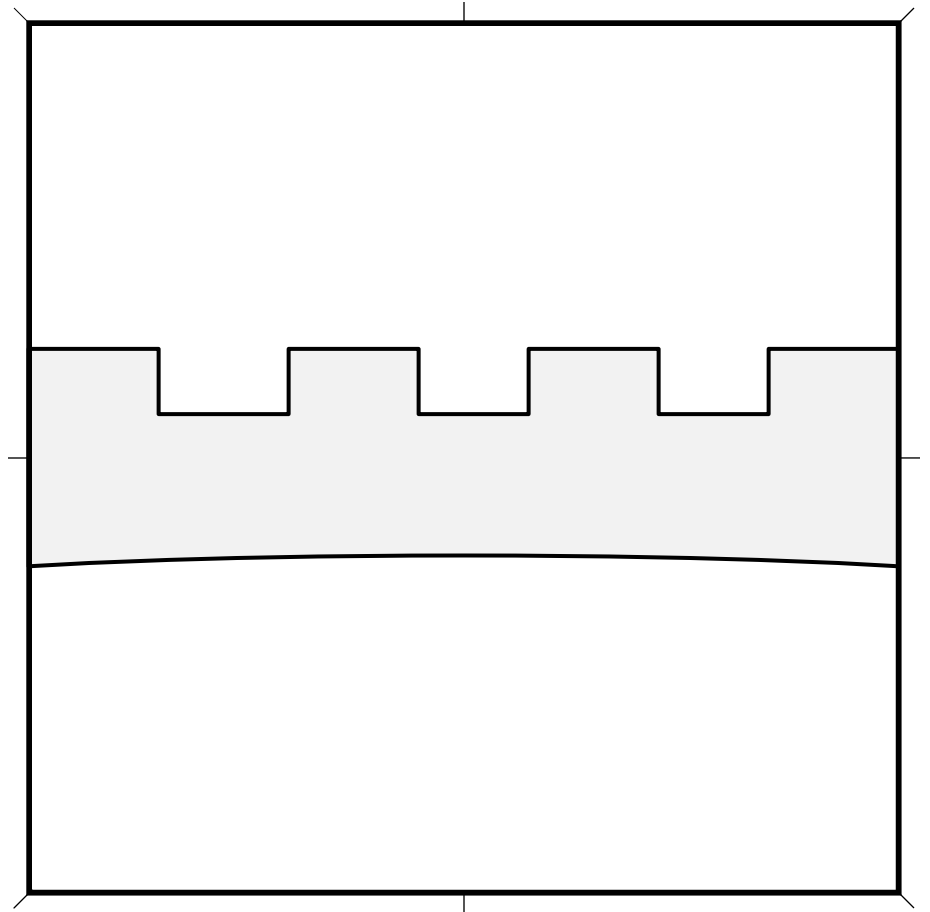

Fess Embattled (3) 4.410

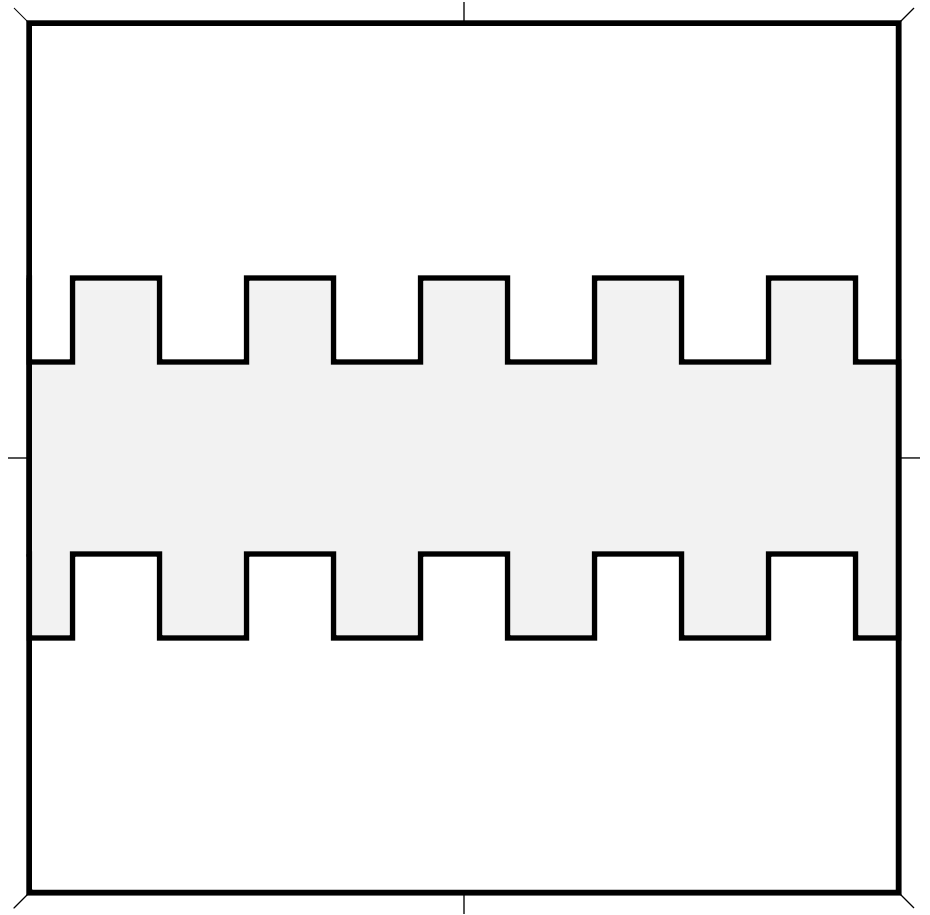
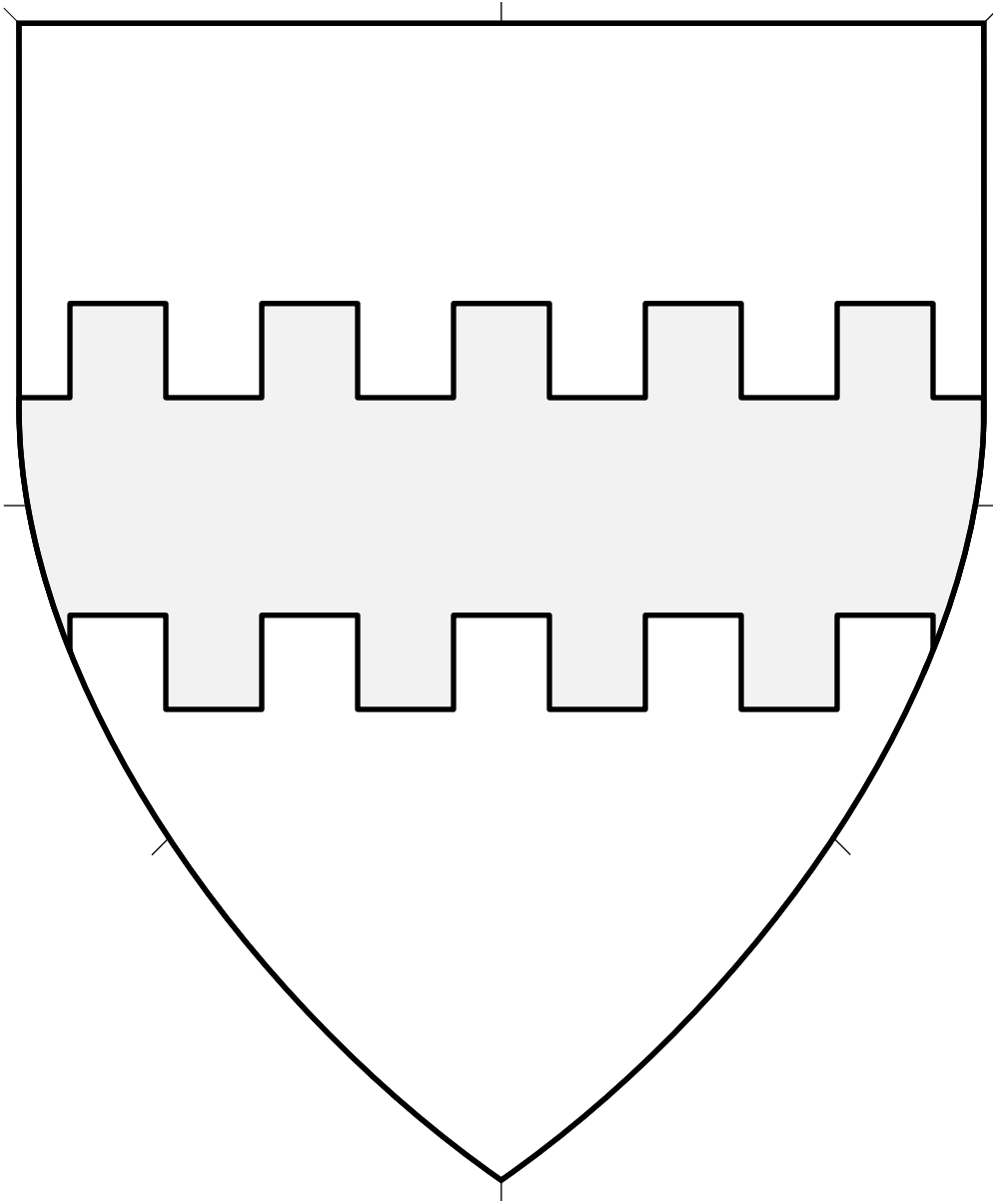

Central ordinary.

Fess Embattled Counter-embattled (1) 4.411

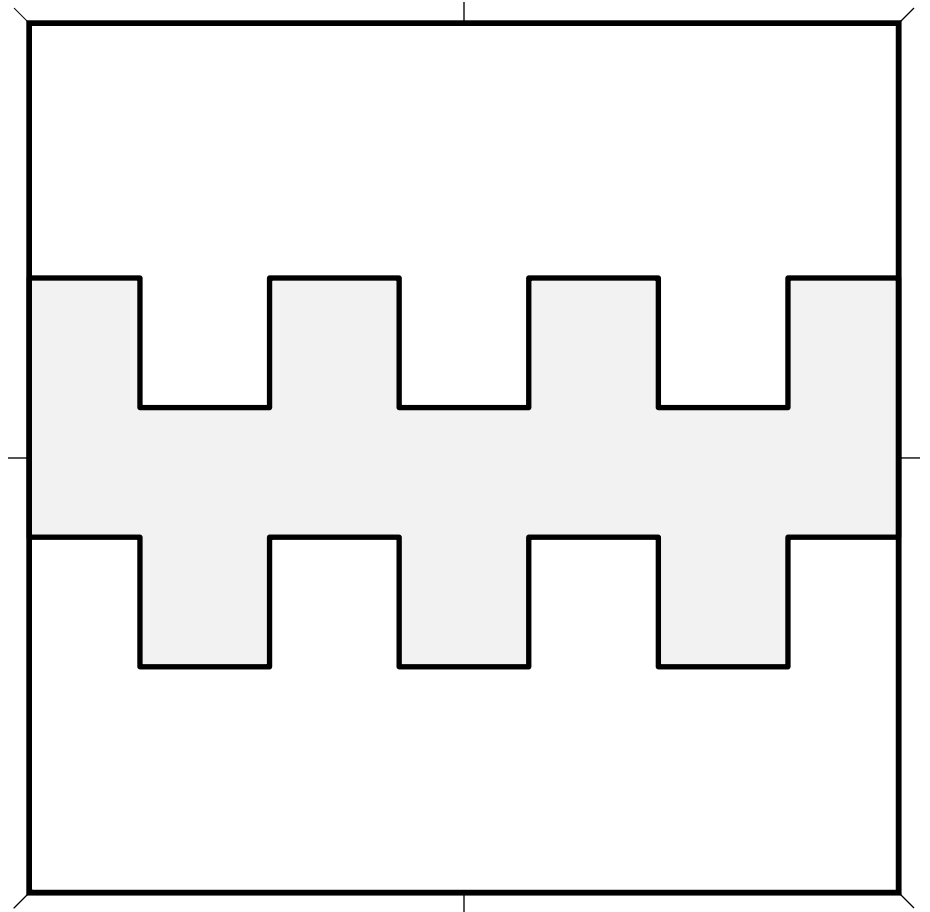
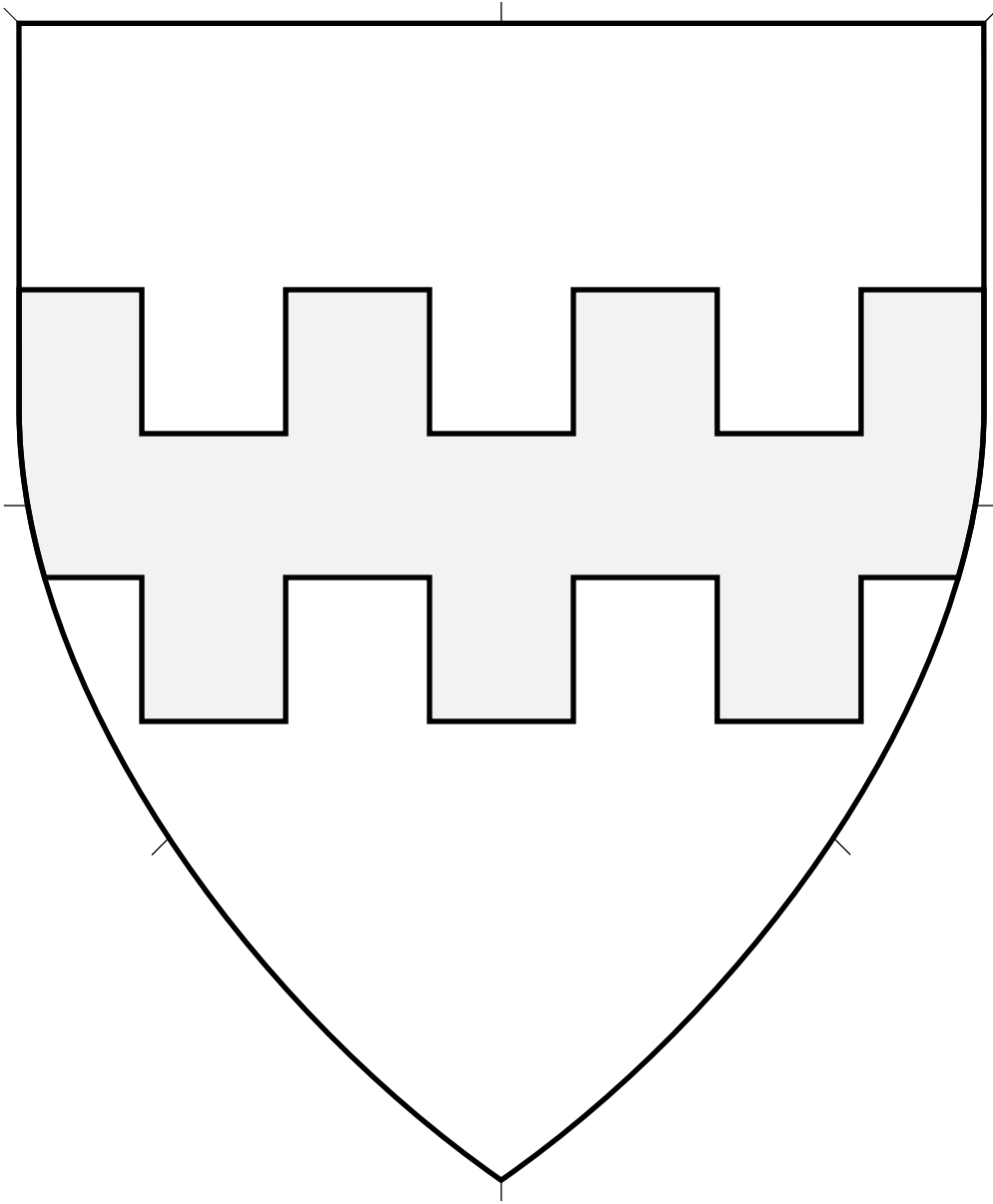

Central ordinary.
Source: Bellenville Armorial.
Artist unknown. (Folio 50r.)

Fess Embattled Counter-embattled (2) 4.412

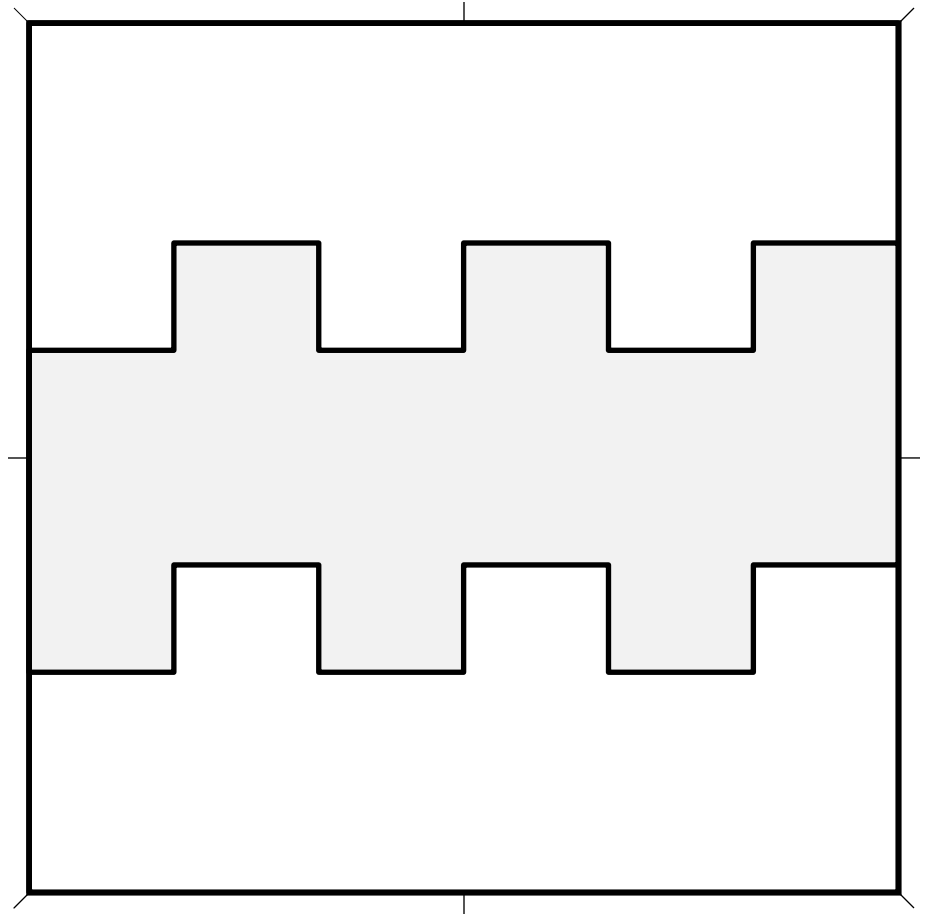
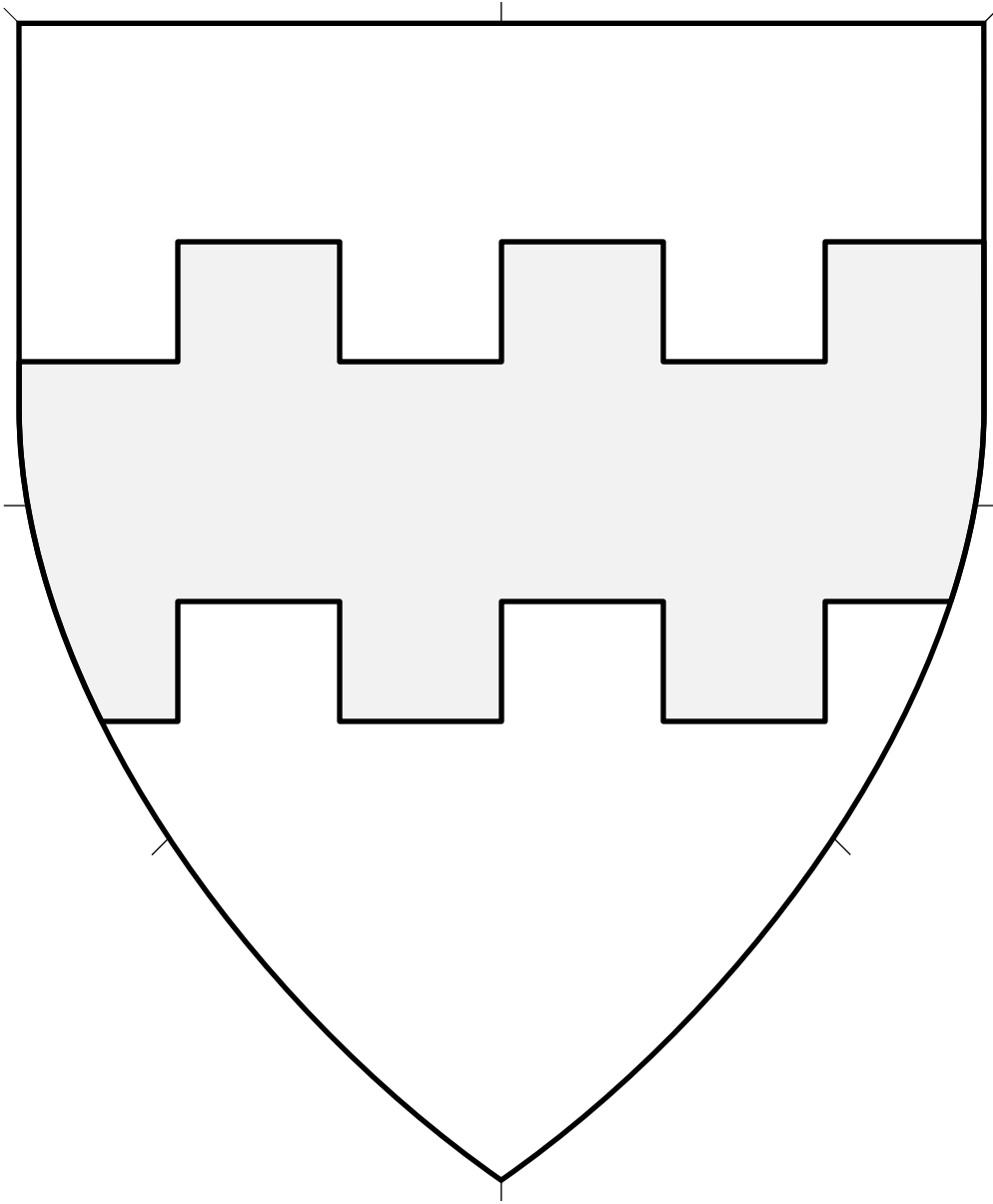

Central ordinary.

Source: Utrecht Archives MS 421.
Artist unknown. (View 64.)

Fess Embattled Counter-embattled (3) 4.413

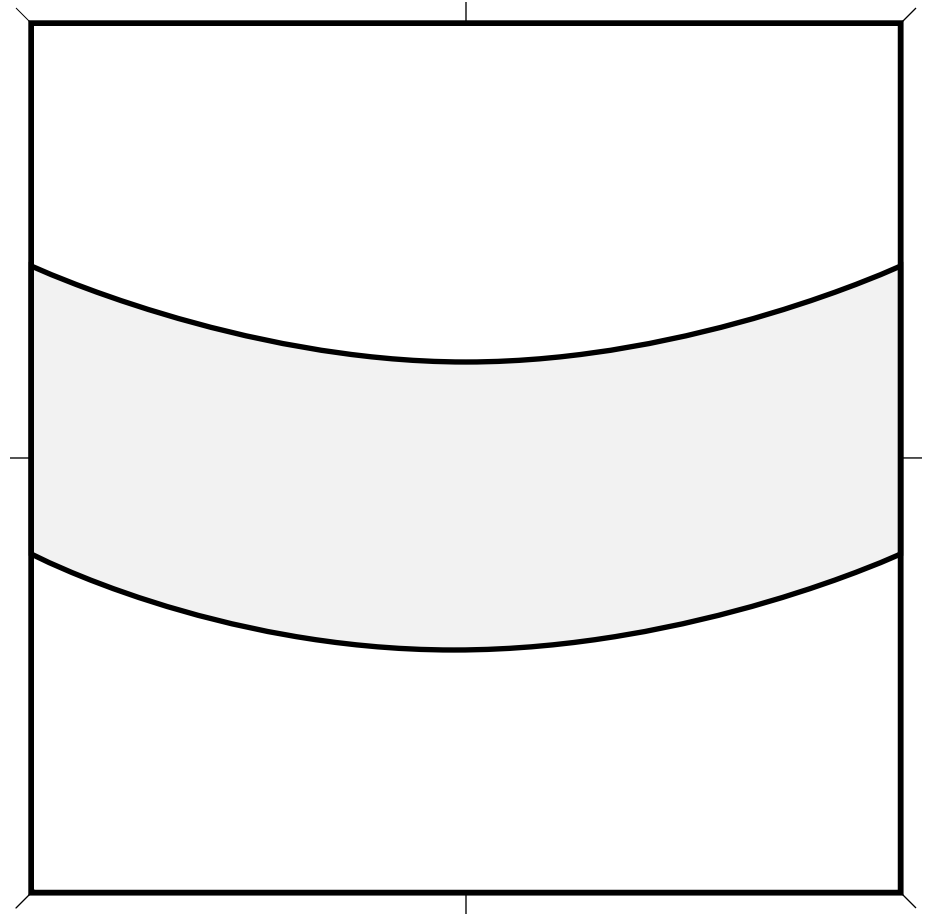
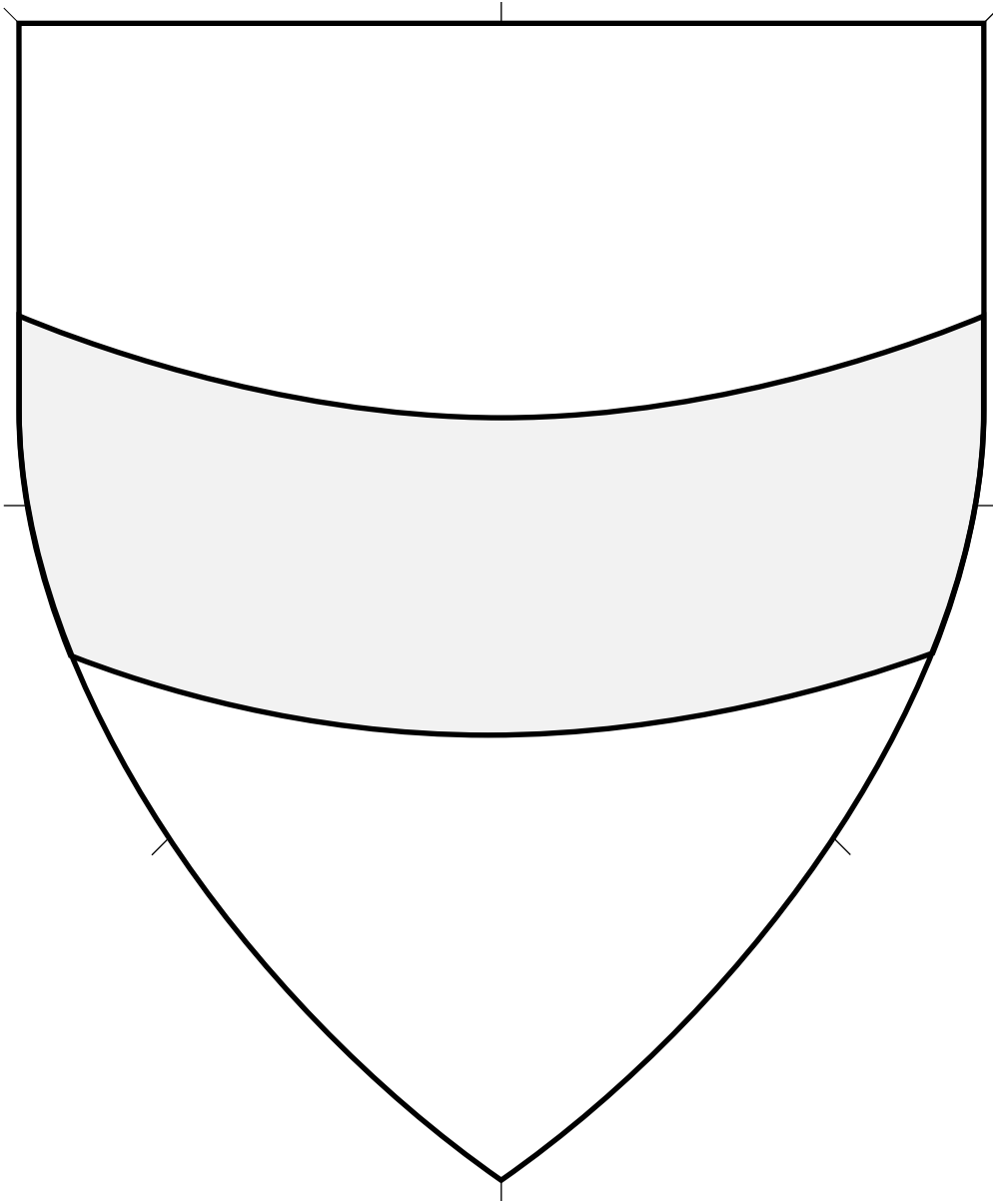

Central ordinary.
This charge is unregistrable as it is not found in period European armory. One example has been registered in the Society, under an IAP for Aztec practice.

Fess Embowed to Base 4.414

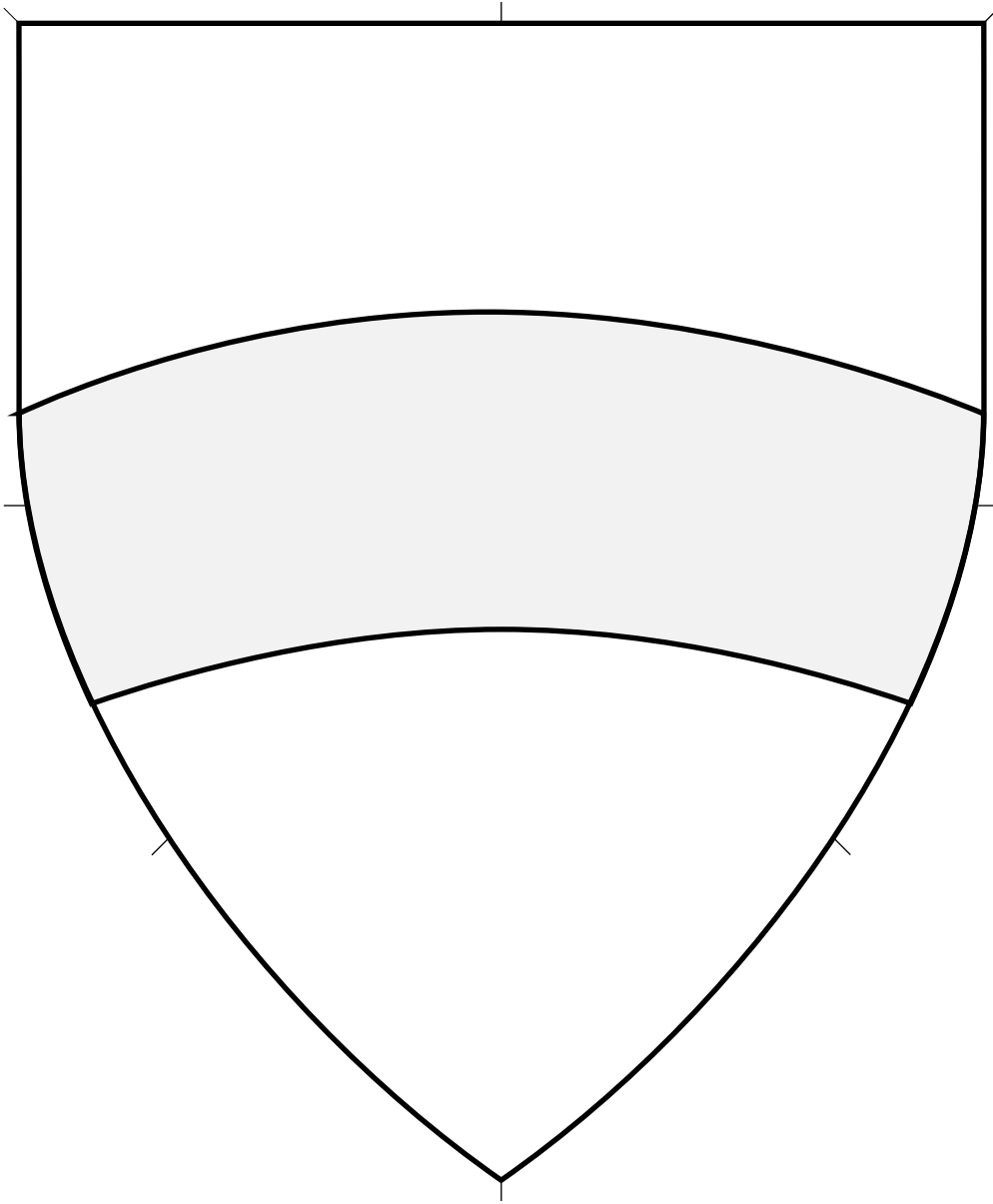

Central ordinary.

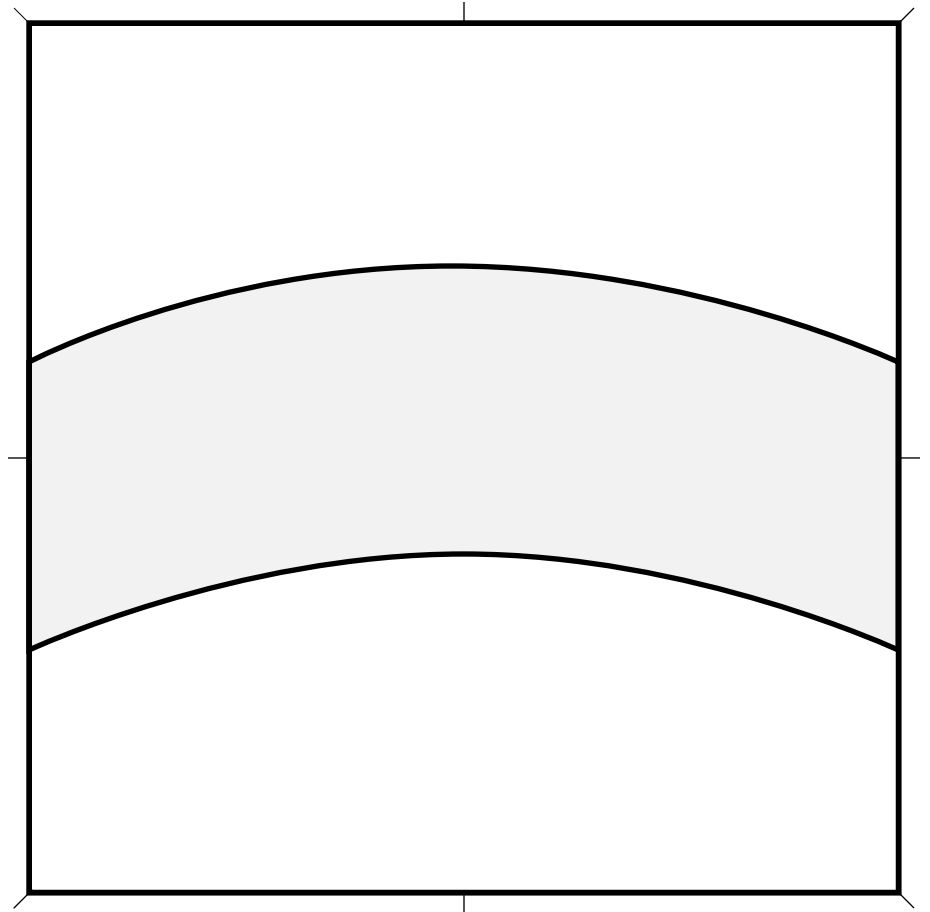

Fess Enarched 4.415

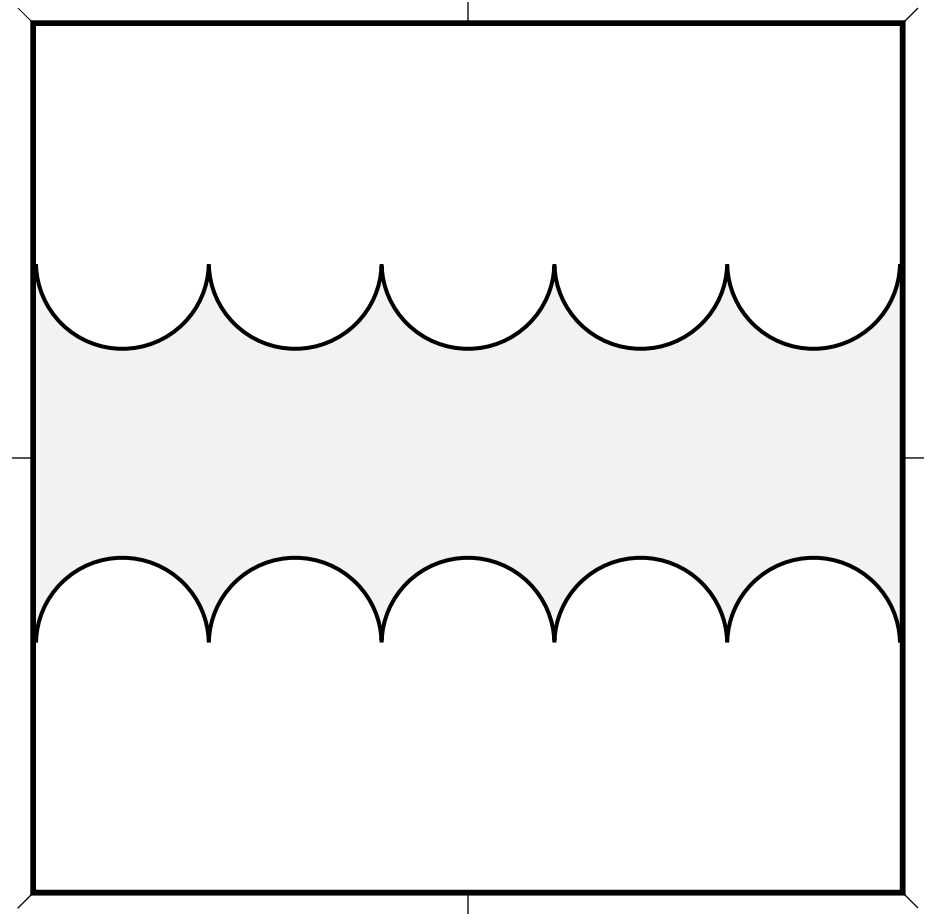
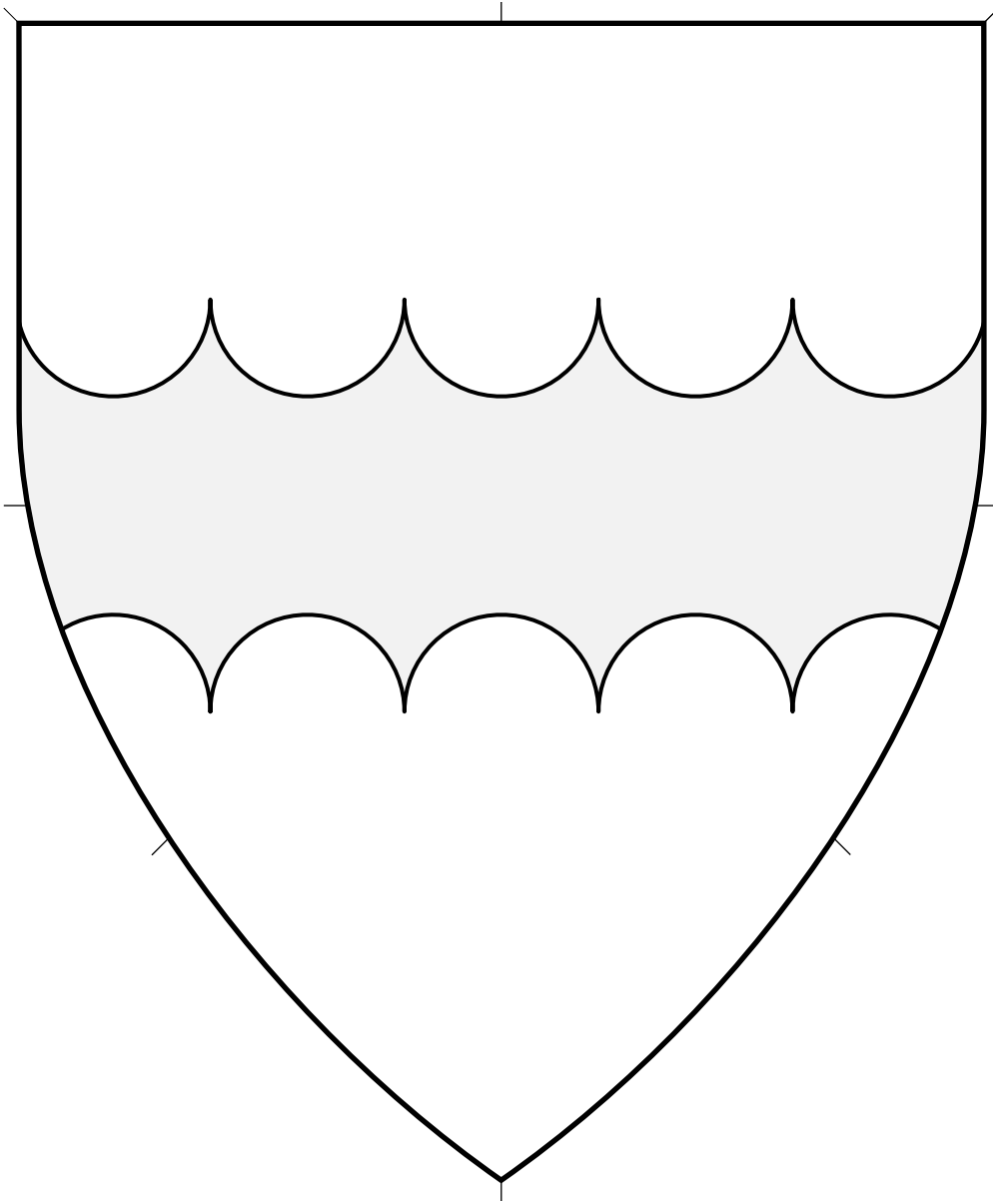

Central ordinary.

Fess Engrailed (1) 4.416

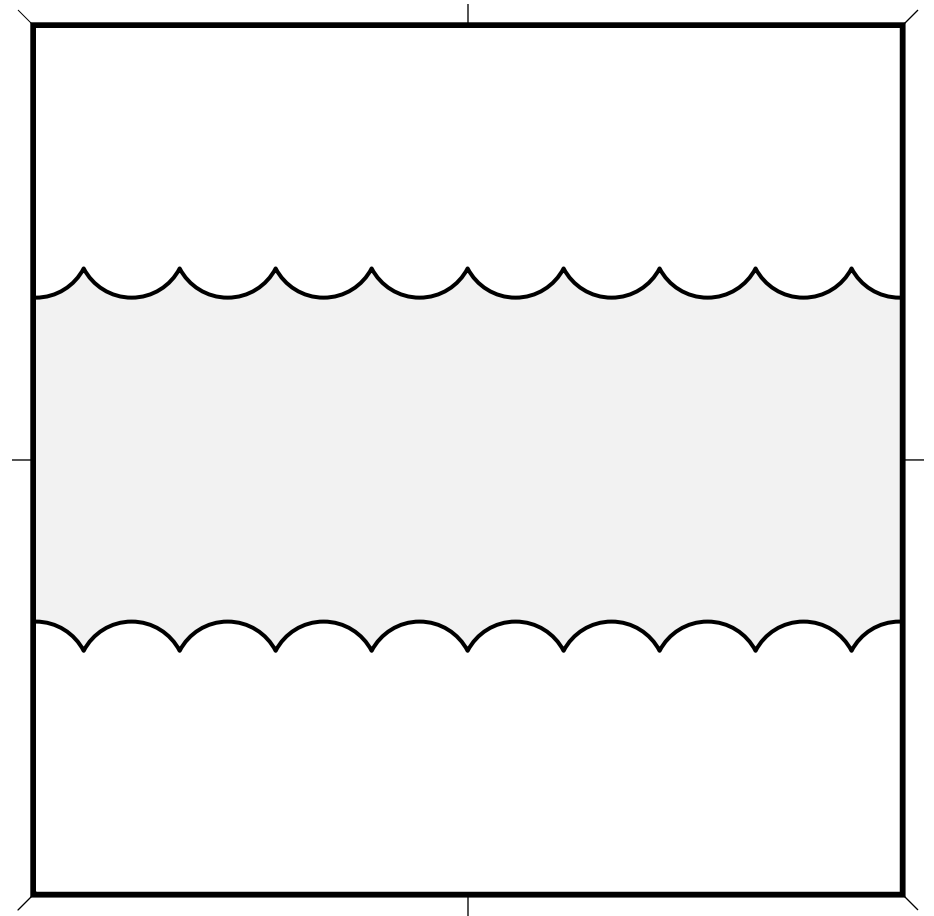
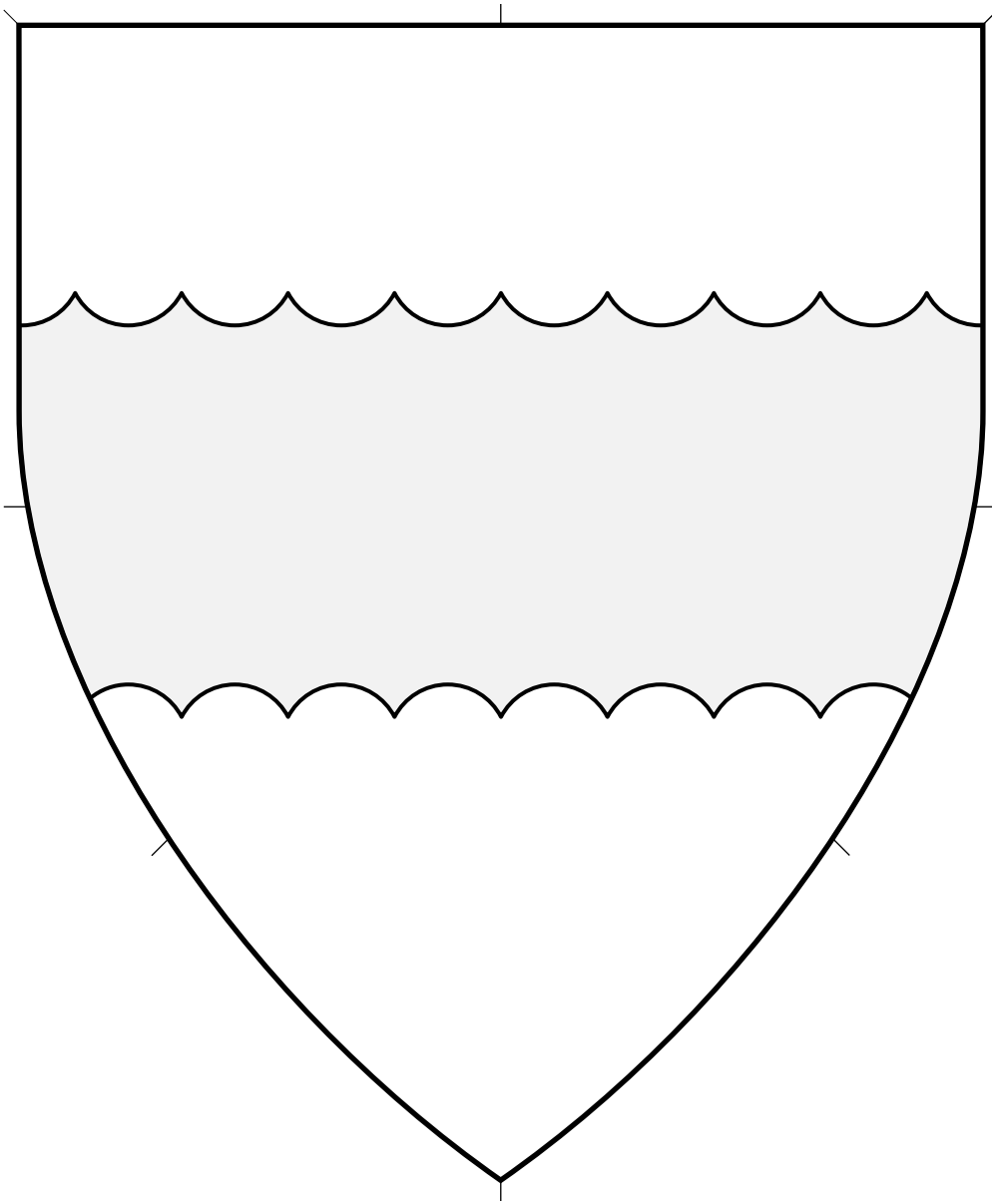

Central ordinary.

Source: Insignia Anglica. Artist unknown.
(Folio 47v.)

Fess Engrailed (2) 4.417

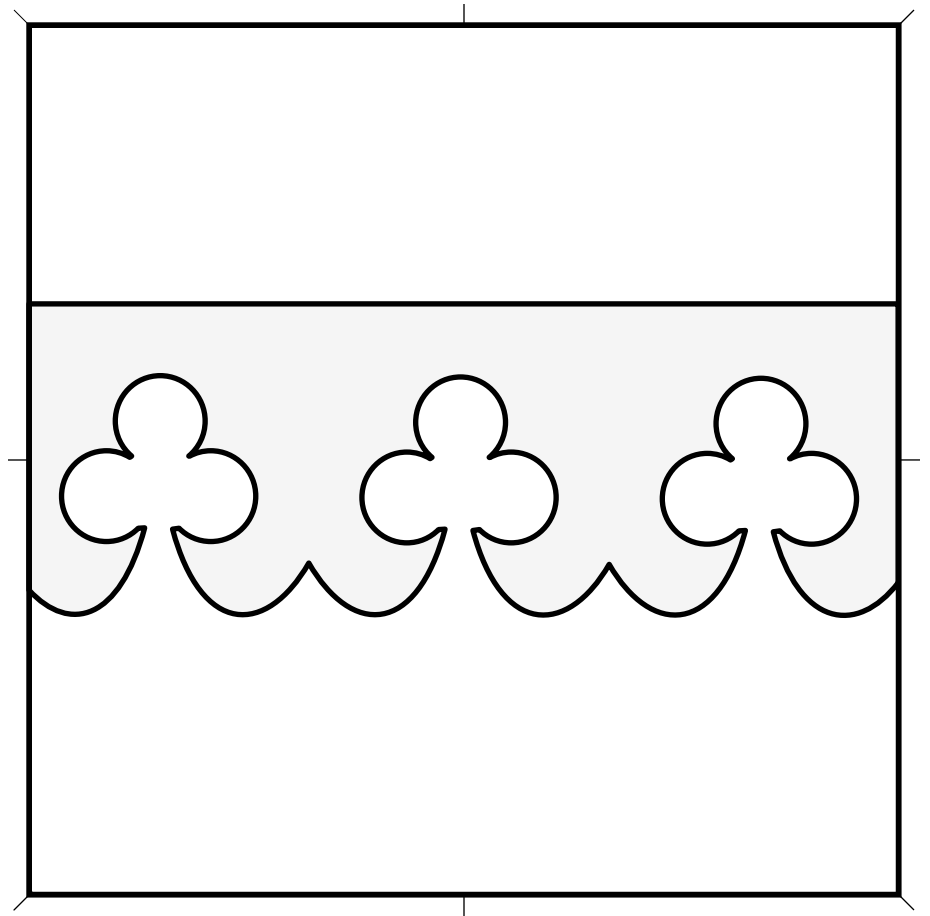
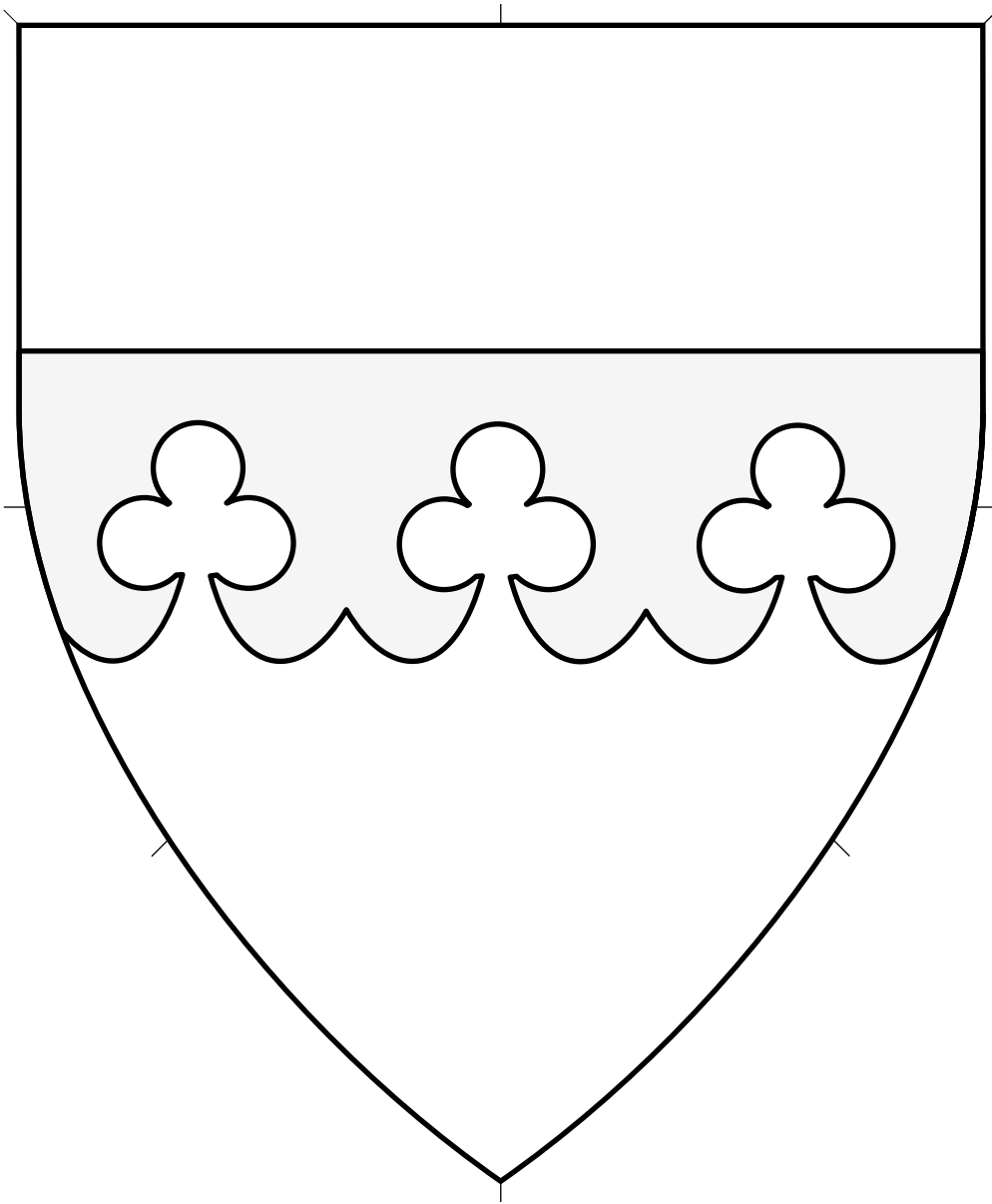

Central ordinary.

Source: St. Gallen Armorial. Artist unknown. Adapted by Vémundr Syvursson.

Fess Invected Trefly on the Bottom Edge 4.418

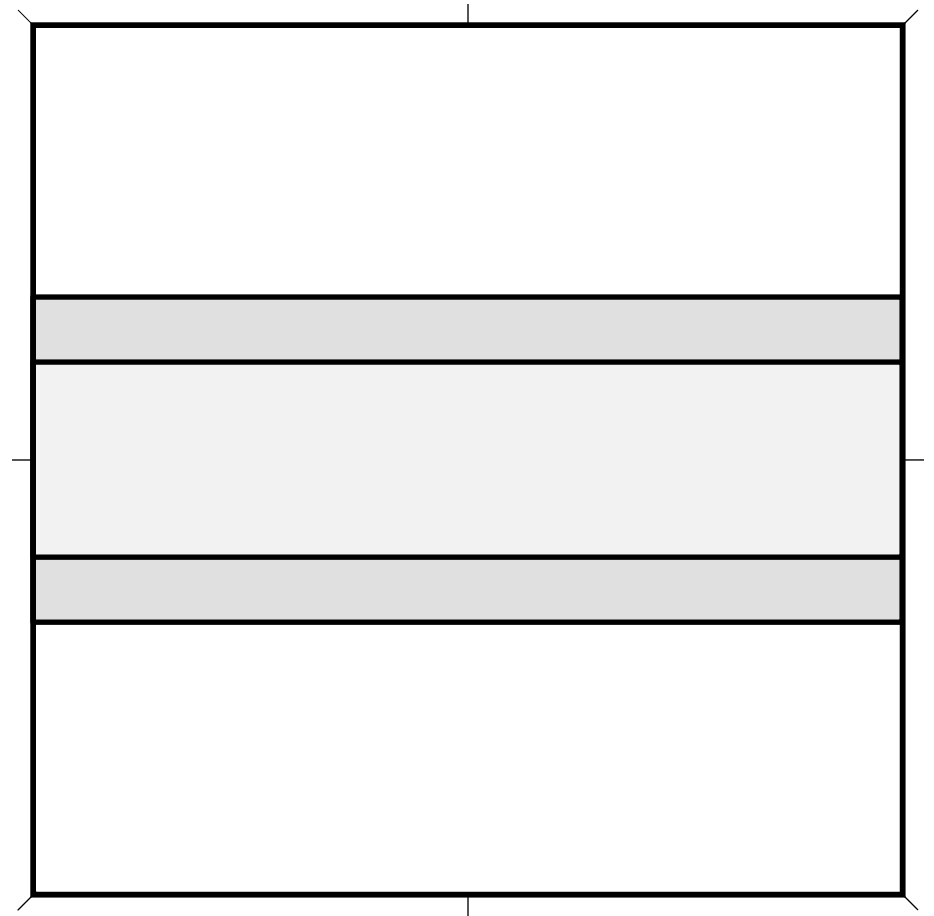
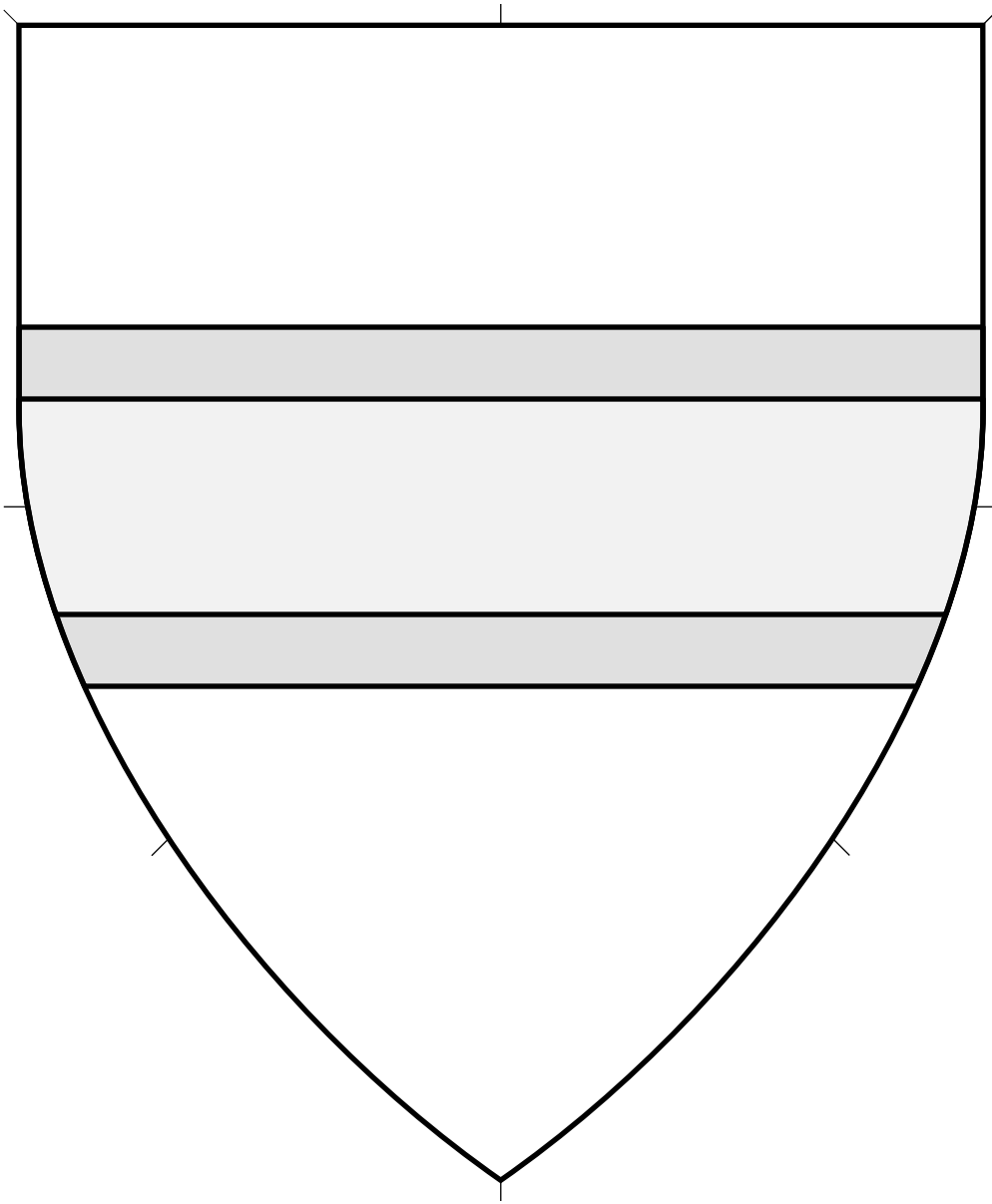

Central ordinary.

Source: BnF MS Allemand 304. Artist unknown. (Page 599.)

Fess Fimbriated 4.419

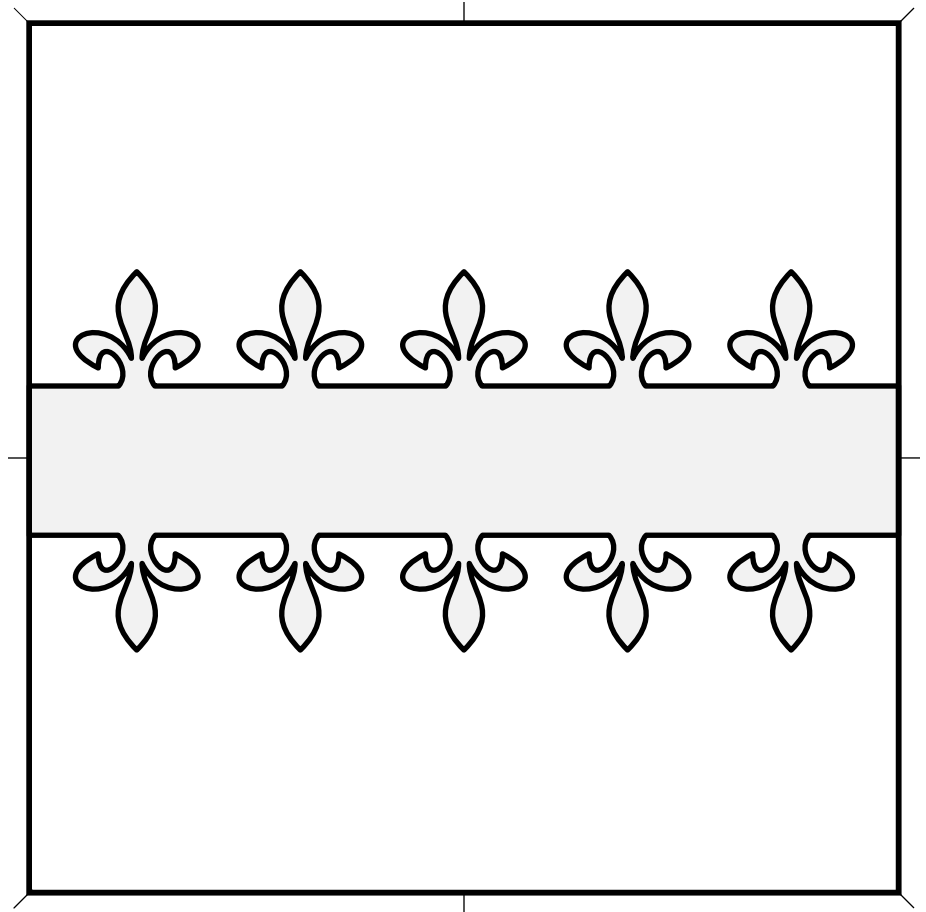
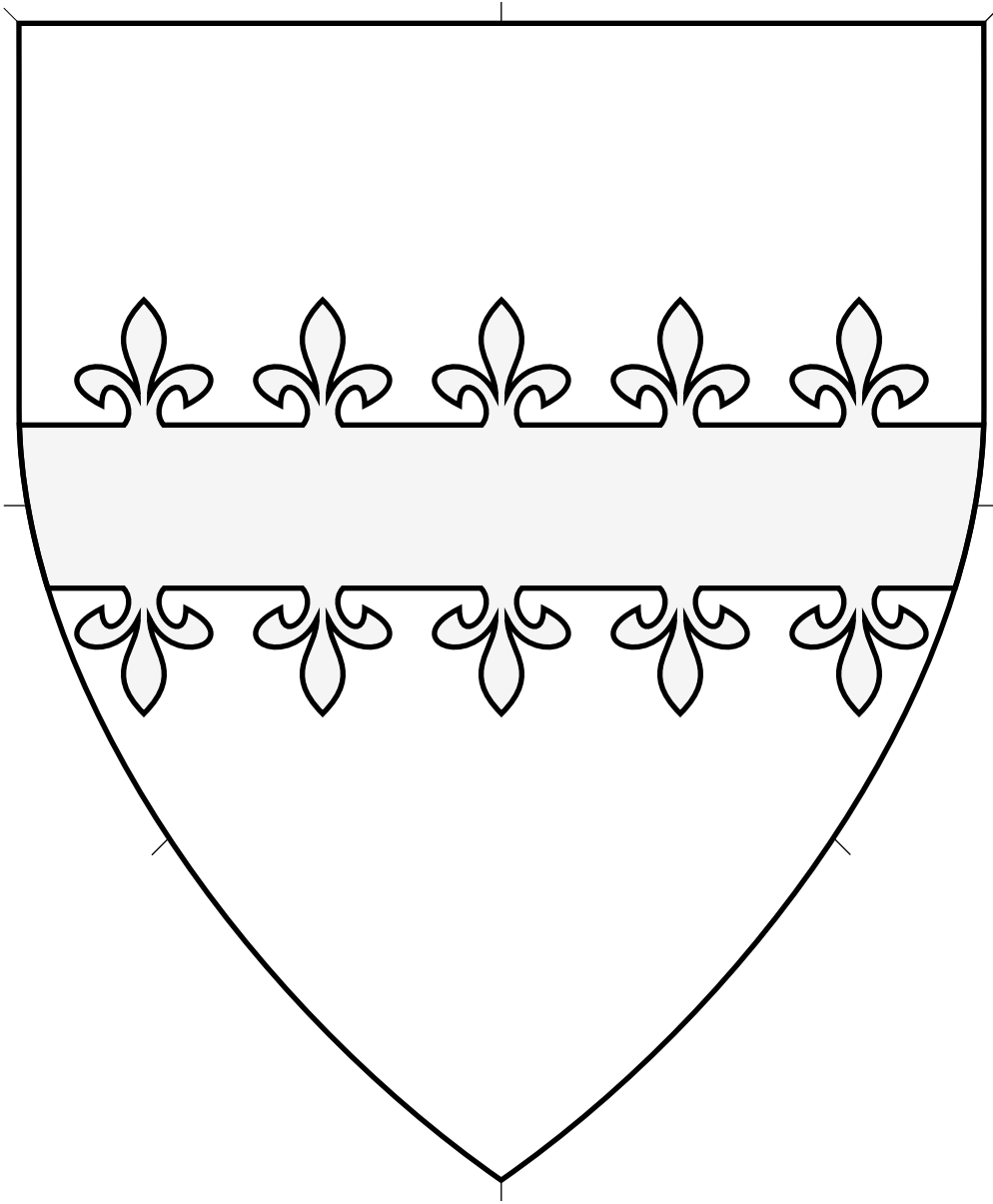

Central ordinary.

Combining a central ordinary flory with other charges would be a Step from Core Practice (SFCP).

Fess Flory 4.420

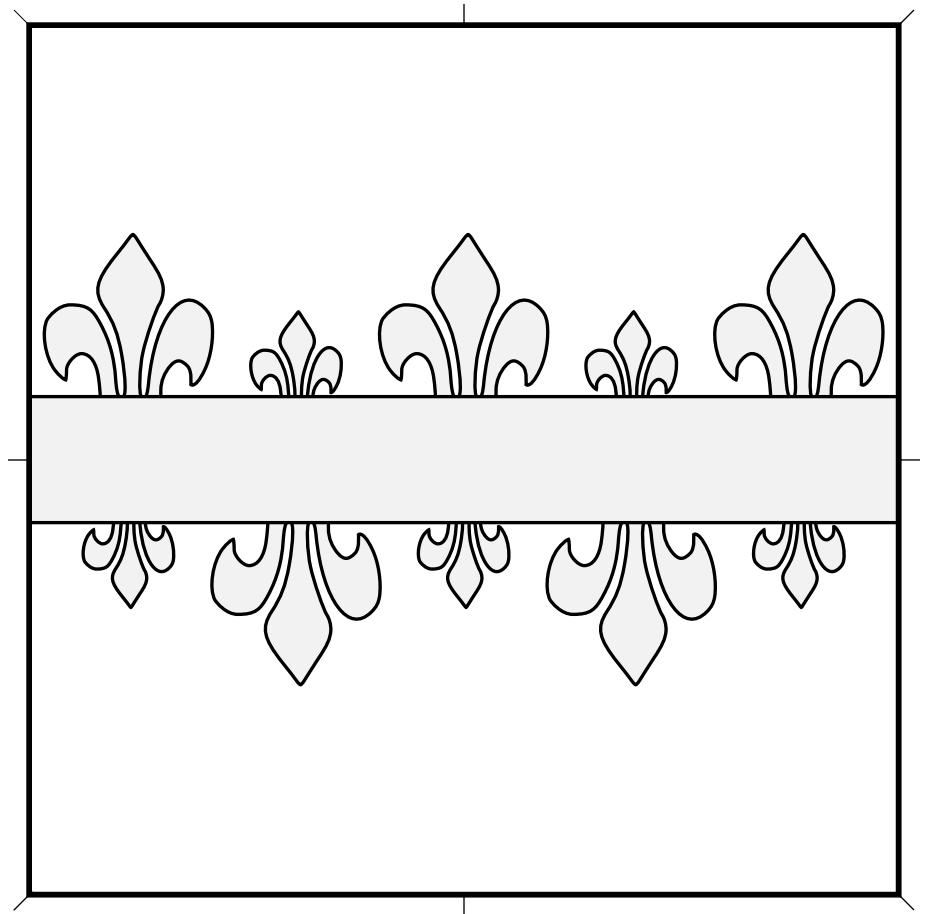
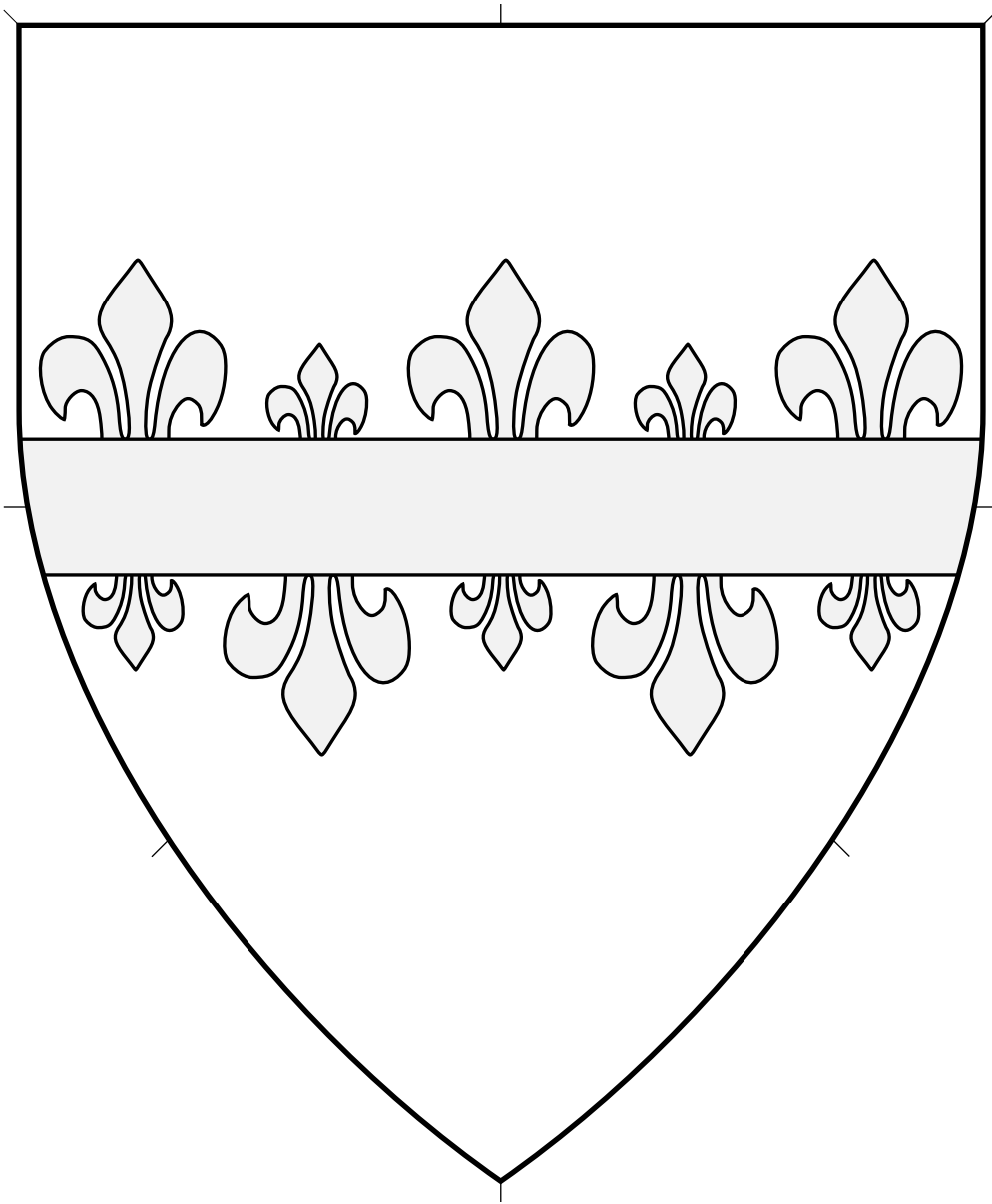

Central ordinary.

Source: Vocabulaire-Atlas Héraldique.
Artist unknown. (Illustration 503.)

Fess Flory Counter-flory 4.421

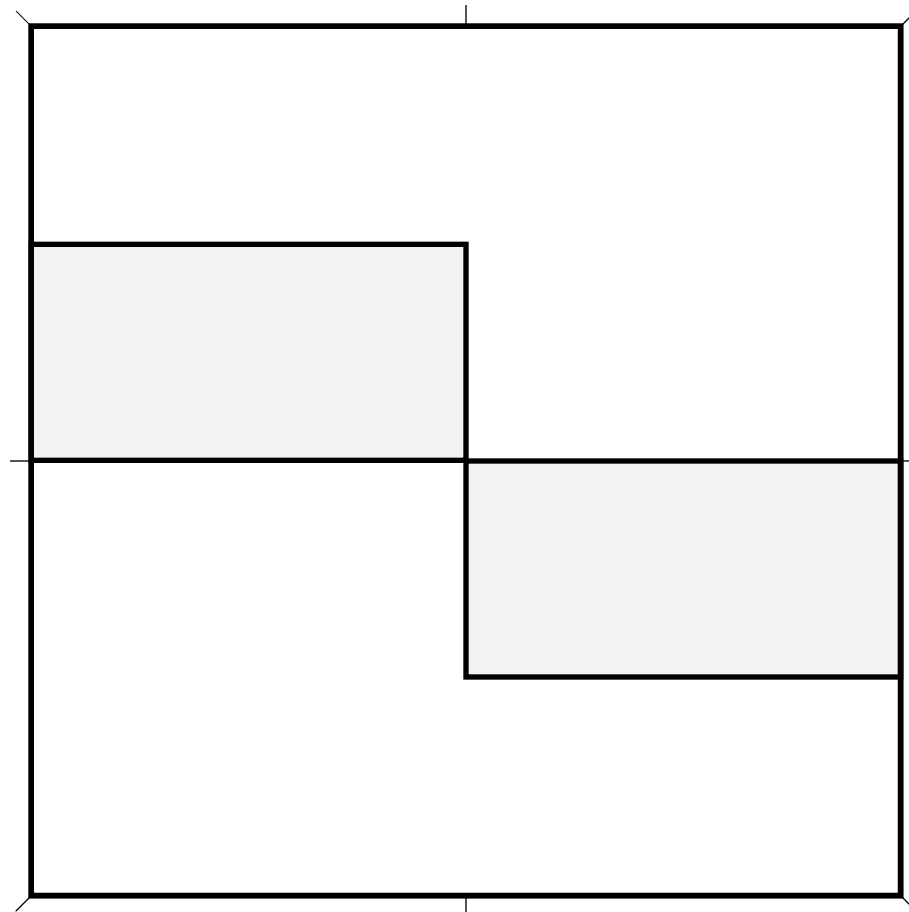
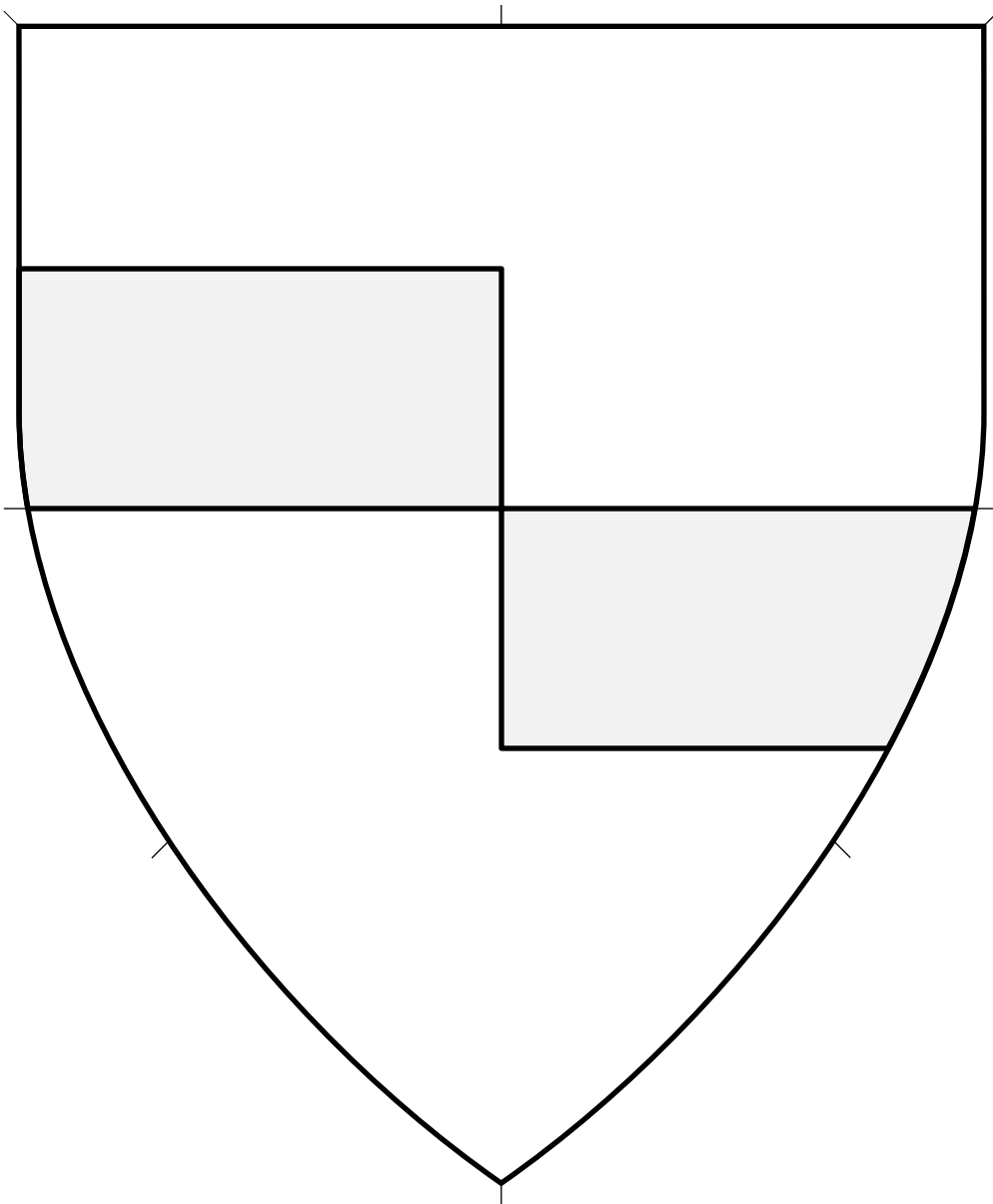

Central ordinary. A fess that is broken and displaced.
Only registered once, in 1980, so may require additional documentation.

Fess Fracted (1) 4.422

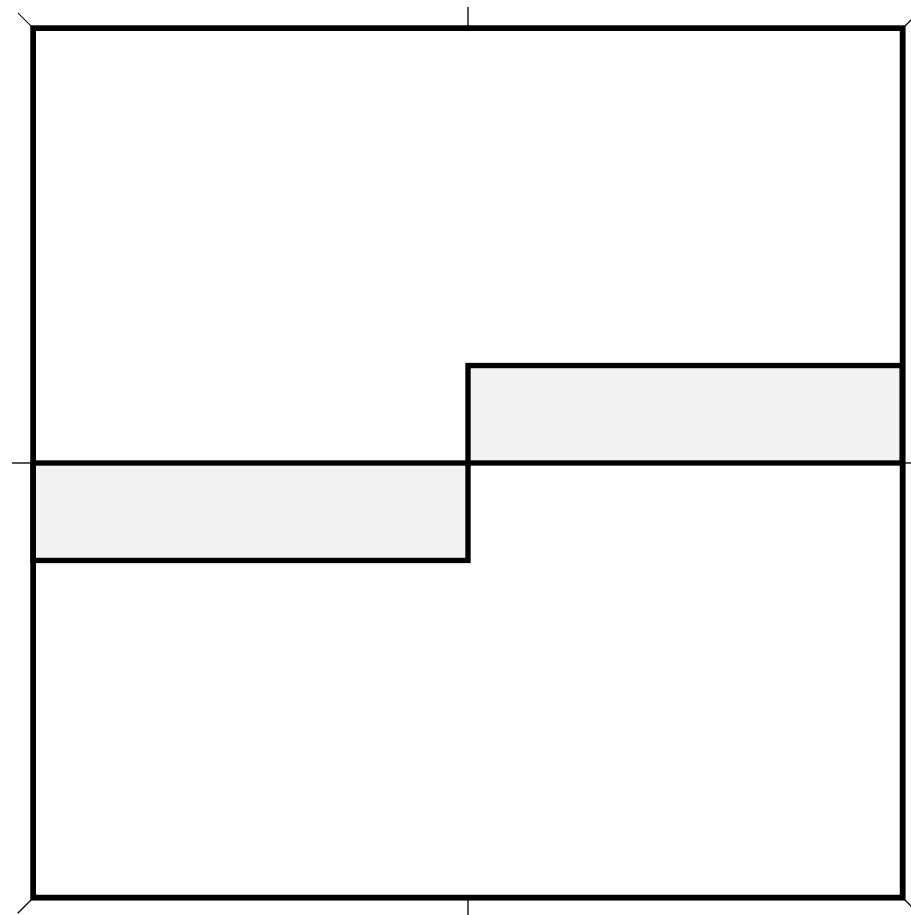
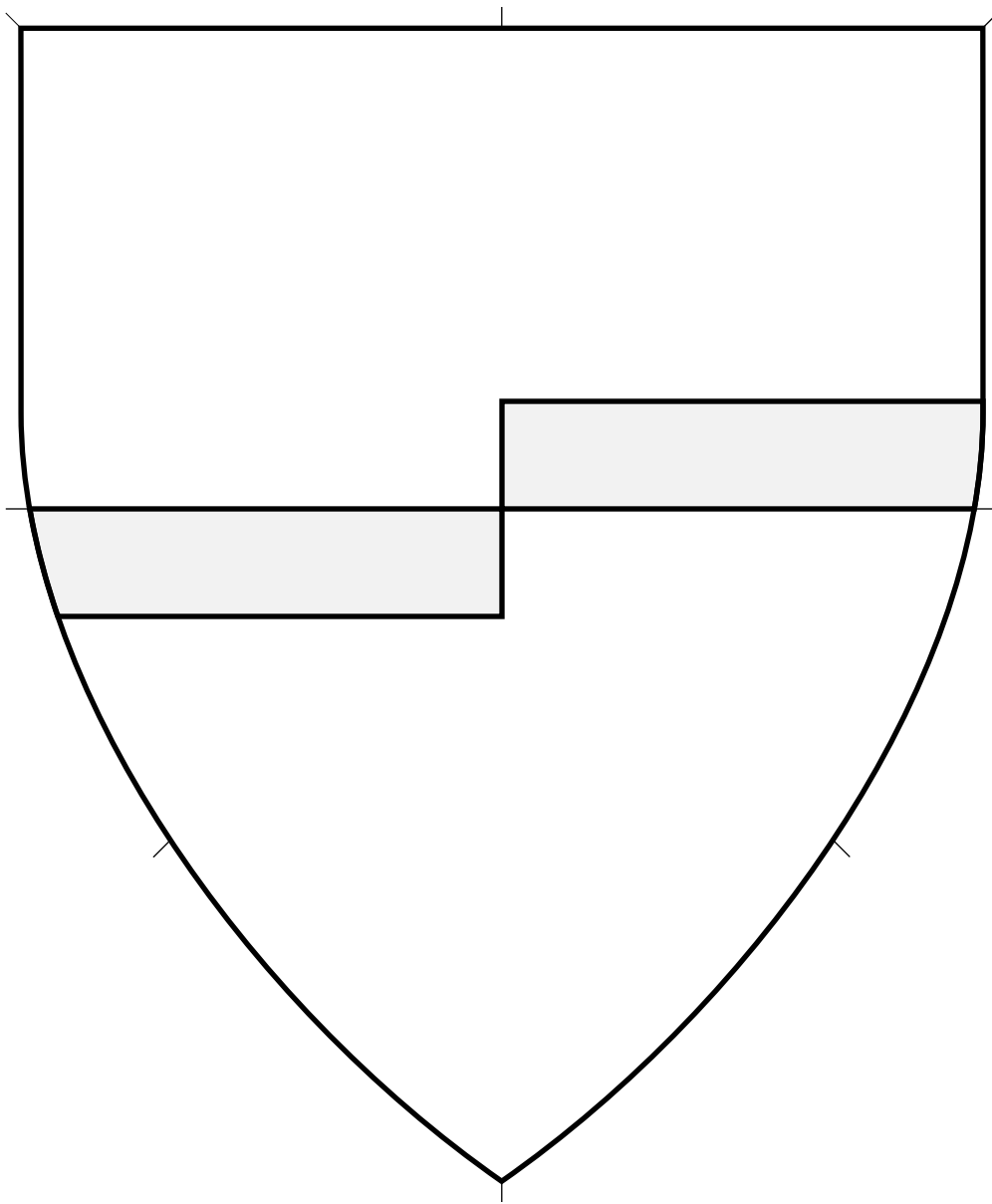

Central ordinary. A fess that is broken and displaced.
Source: Armas de los Cavalleros de Venecia. Artist unknown. (Folio 47v.)

Fess Fracted (2) 4.423

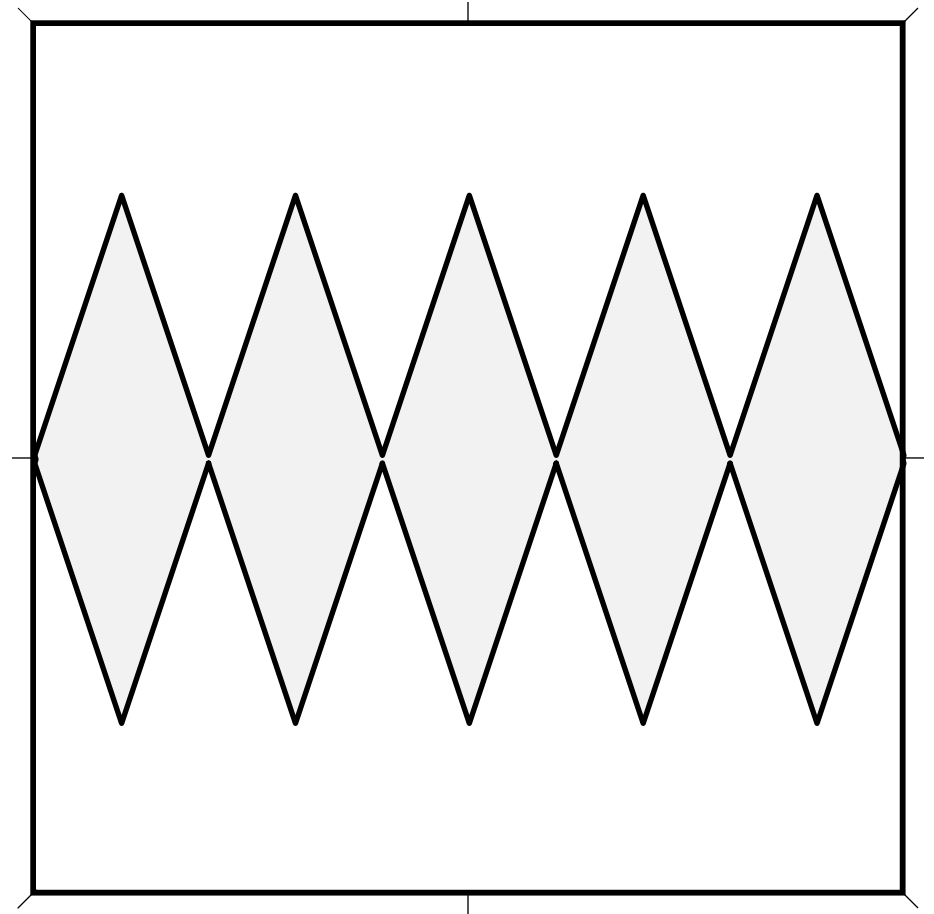
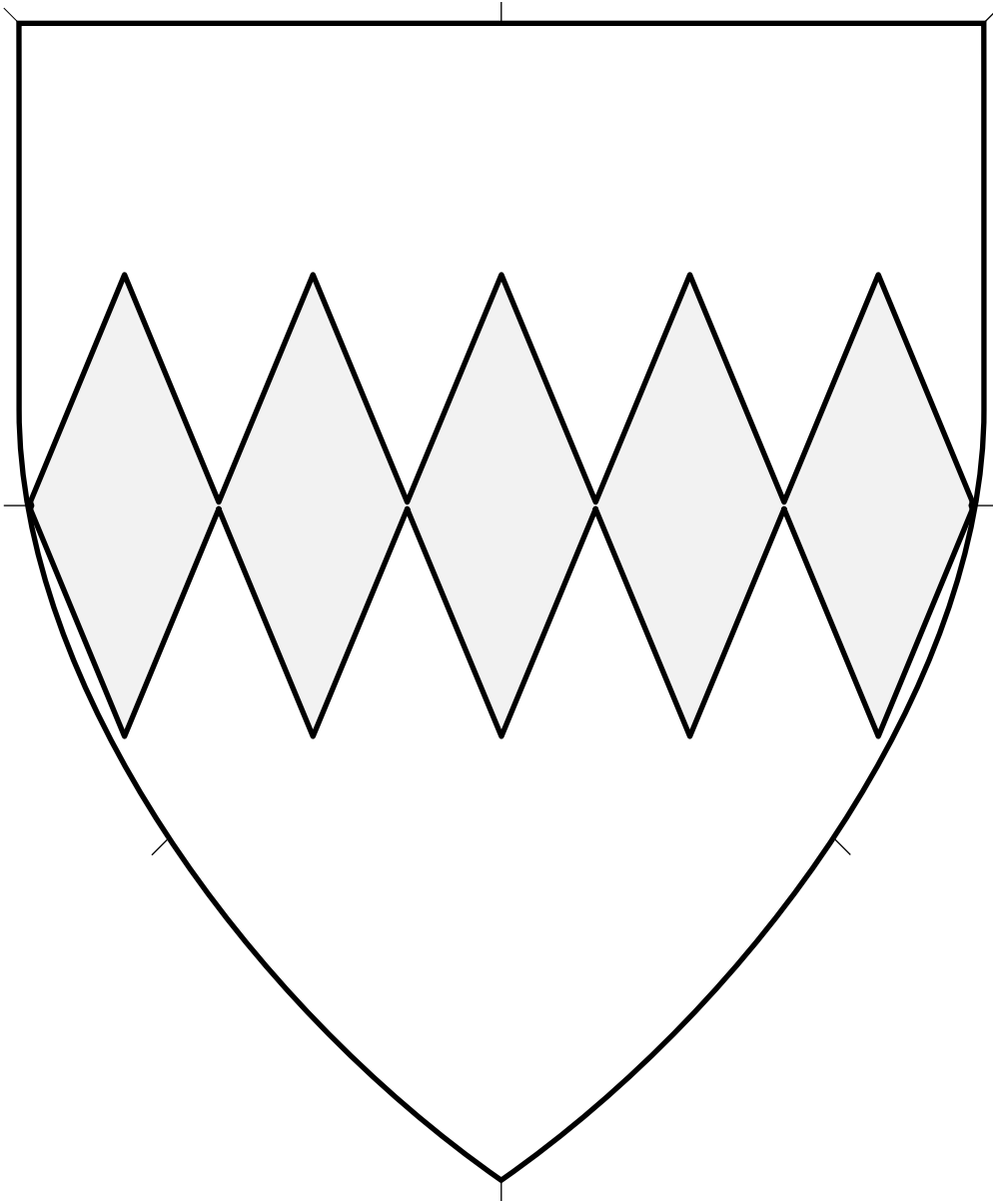

Central ordinary.

Source: Walters Ms. W.847. Artist unknown.
(Arms of William lord Percy, folio 5v.)

Fess Fusilly 4.424

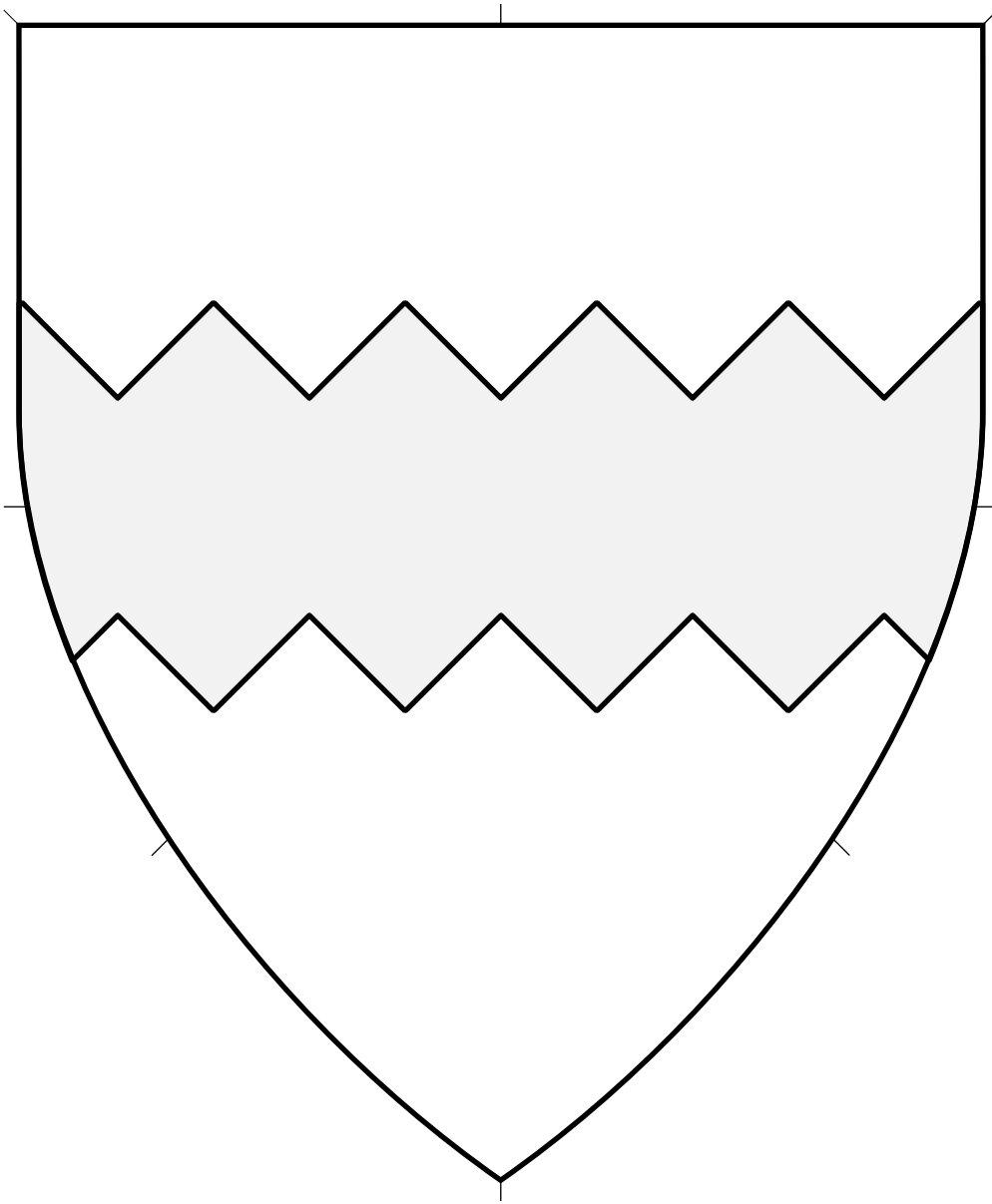

Central ordinary.

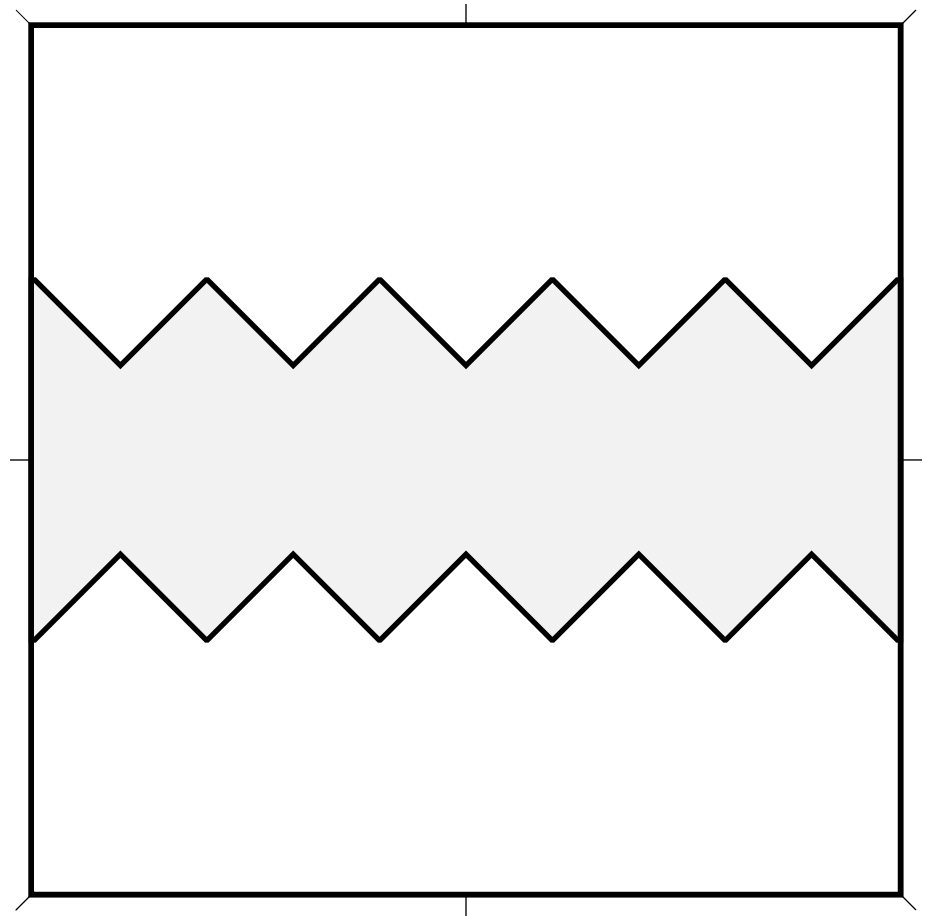

Fess Indented • 4.425

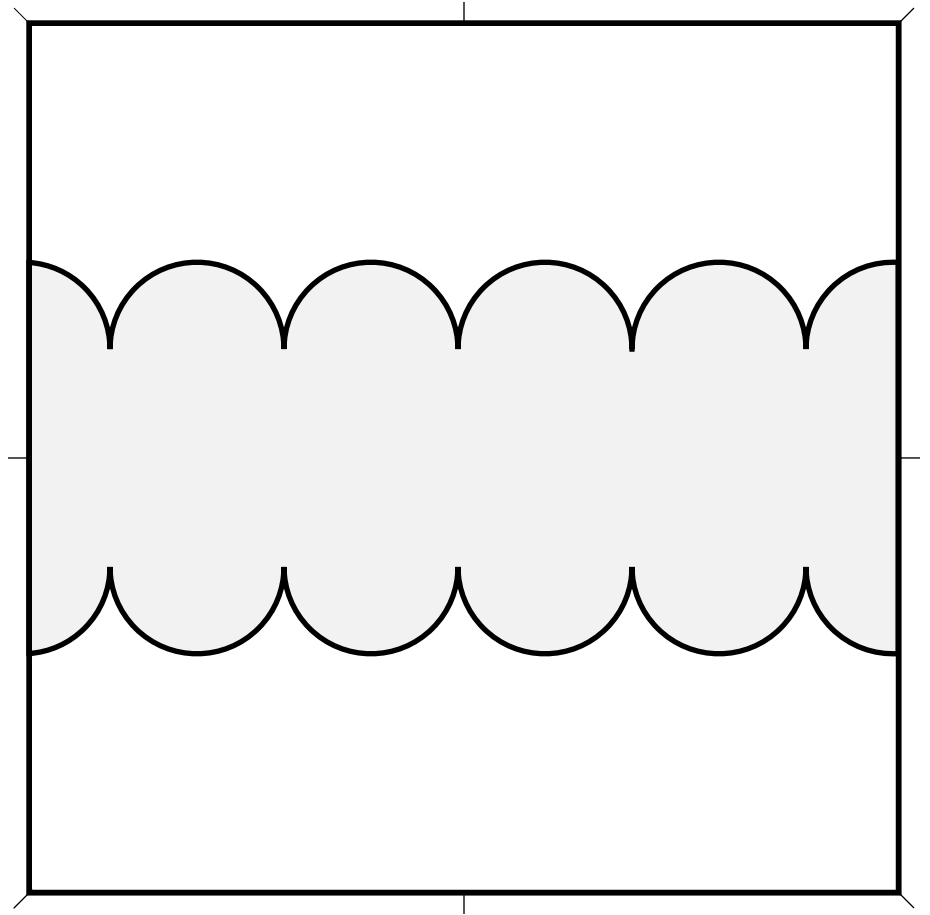
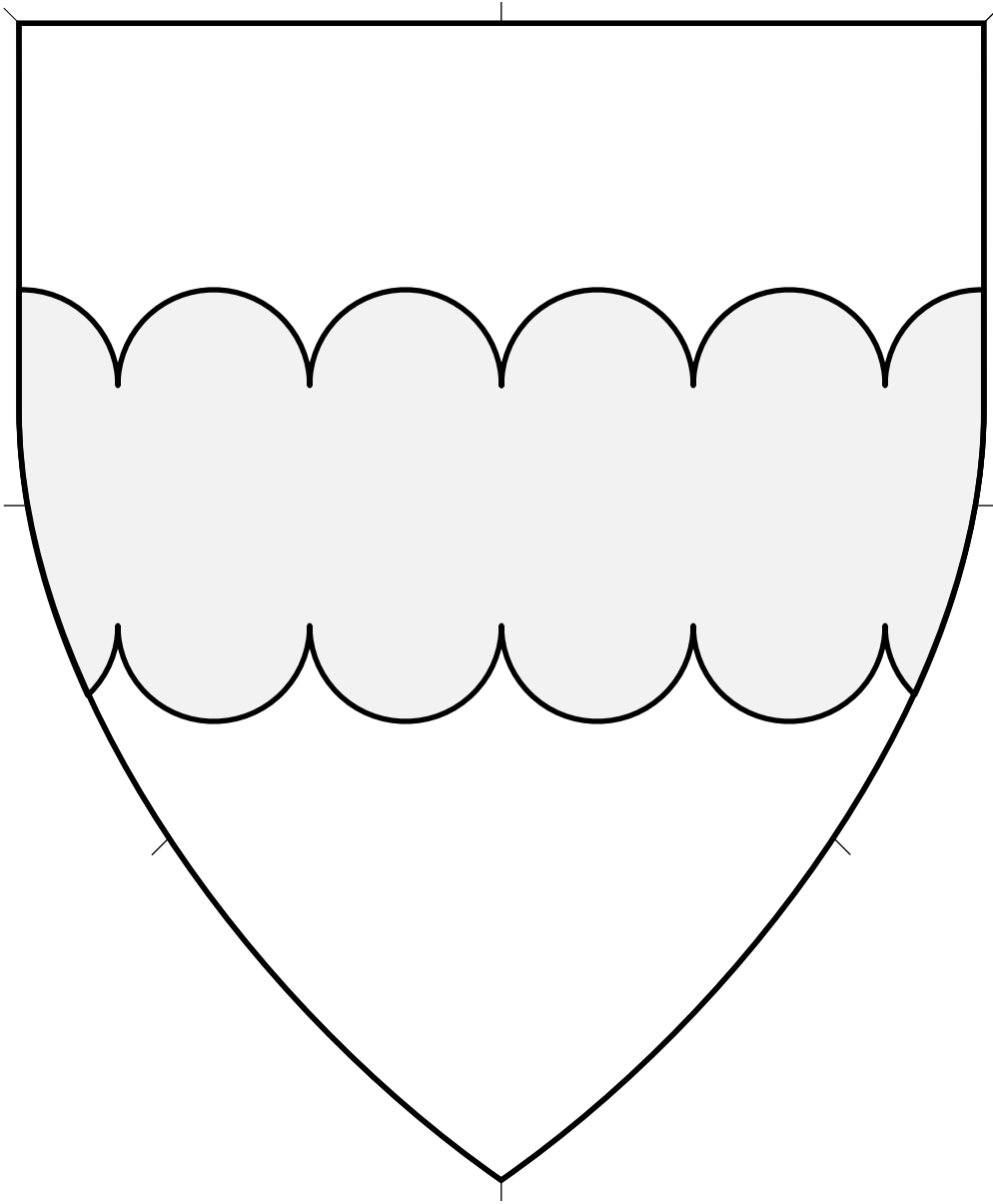

Central ordinary.

Fess Inverted 4.426

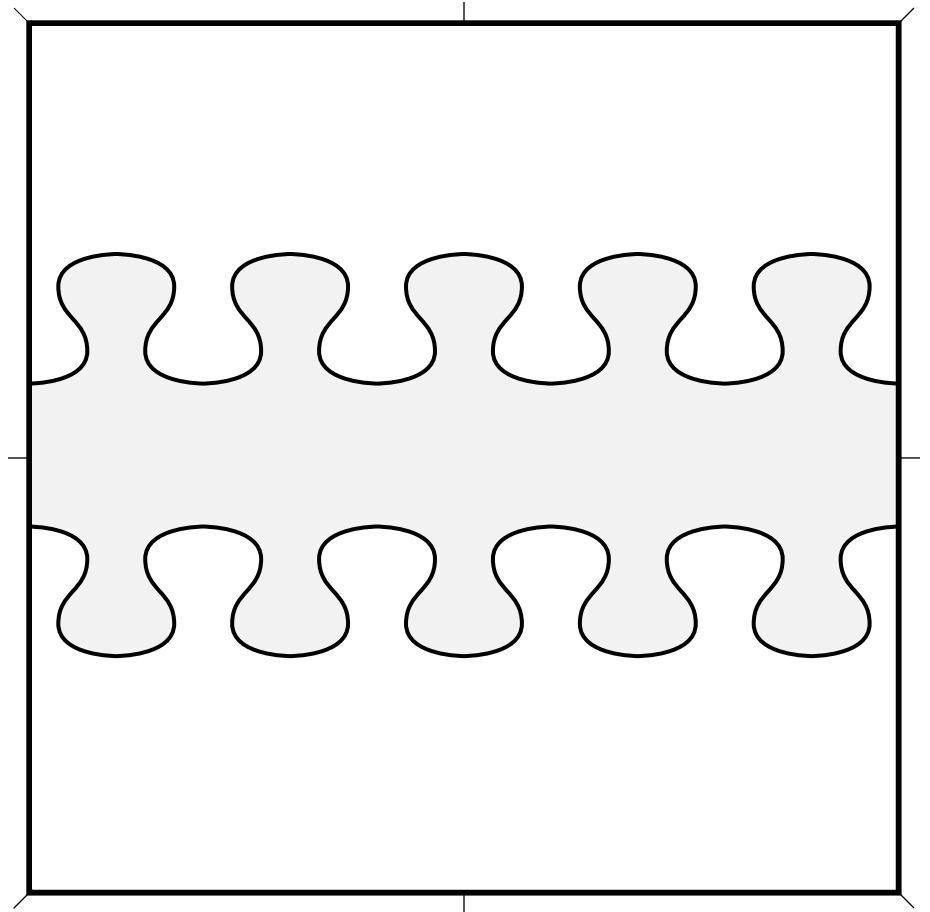
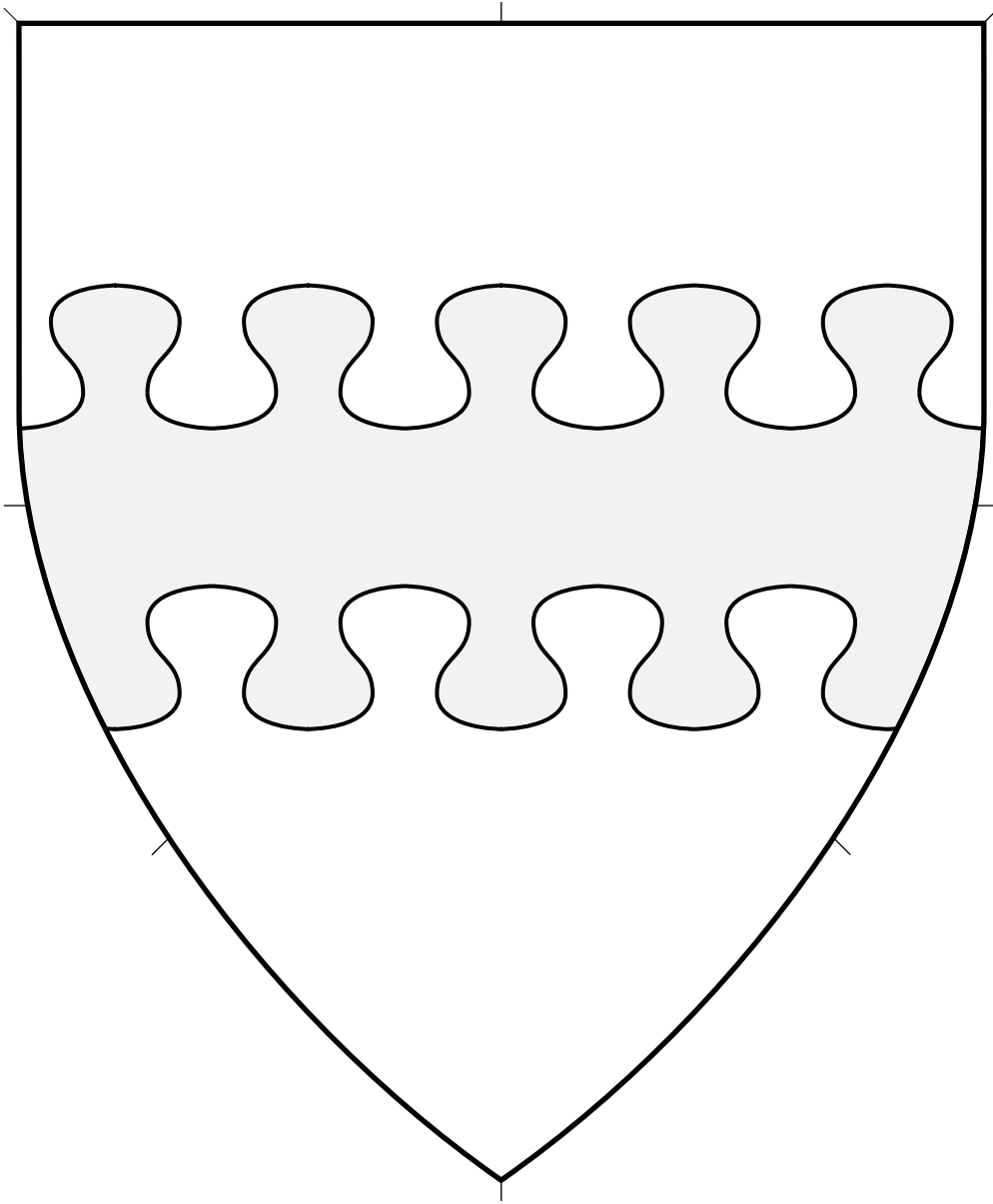

Central ordinary.

Fess Nebuly (1) 4.427

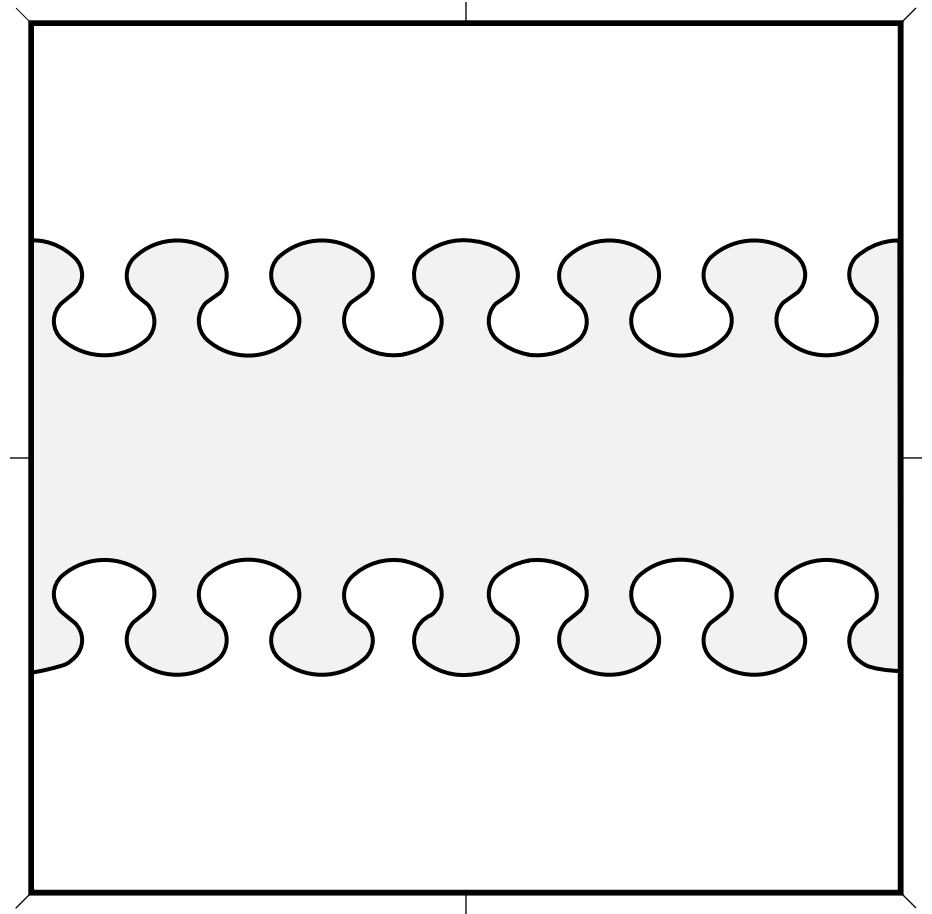
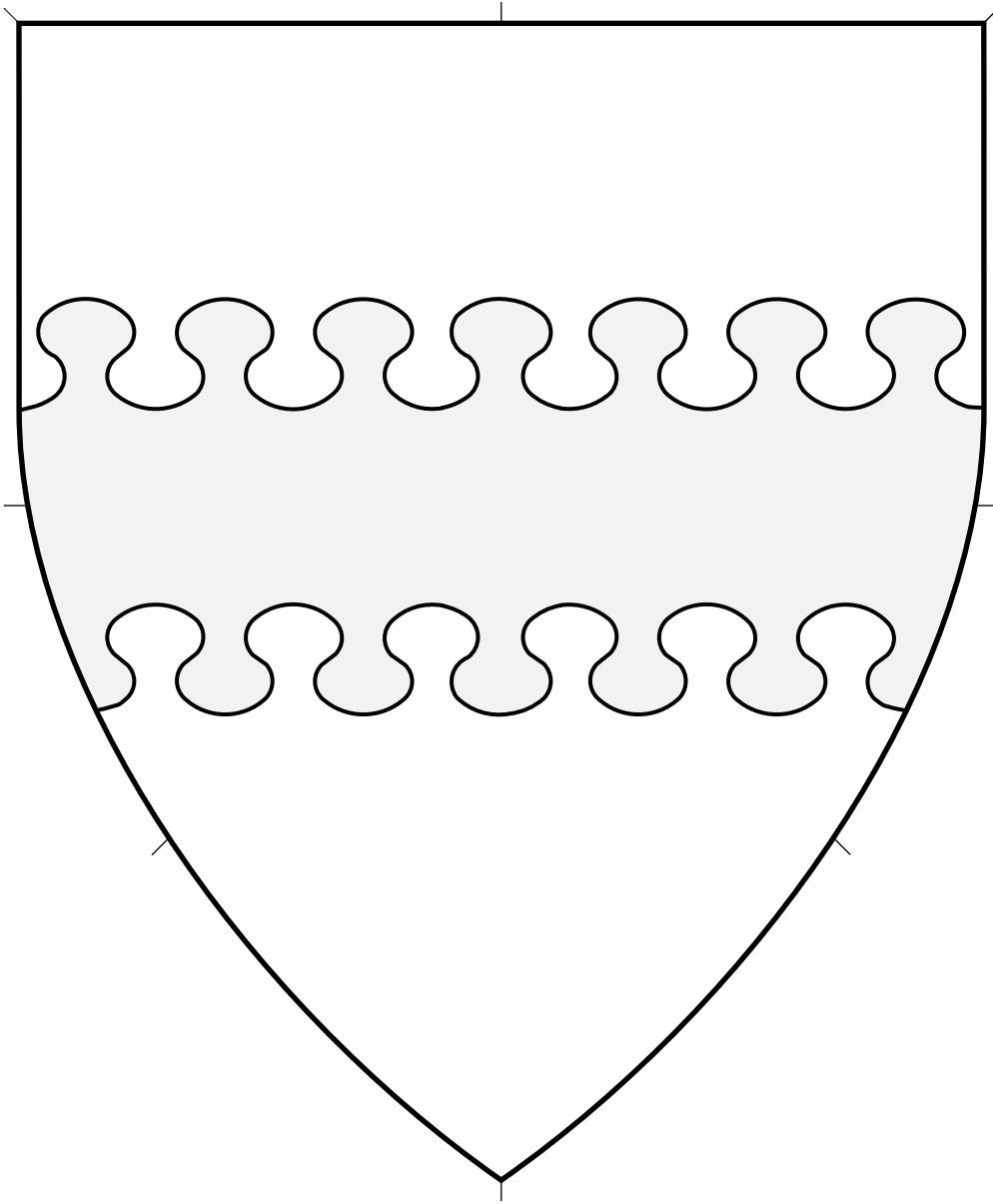

Central ordinary.

Source: Viking Answer Lady SVG Images For Heraldry.
Artist: Gunnvôr silfrahárr. Adapted by Mathghamhain Ua Ruadháin.

Fess Nebuly (2) 4.428

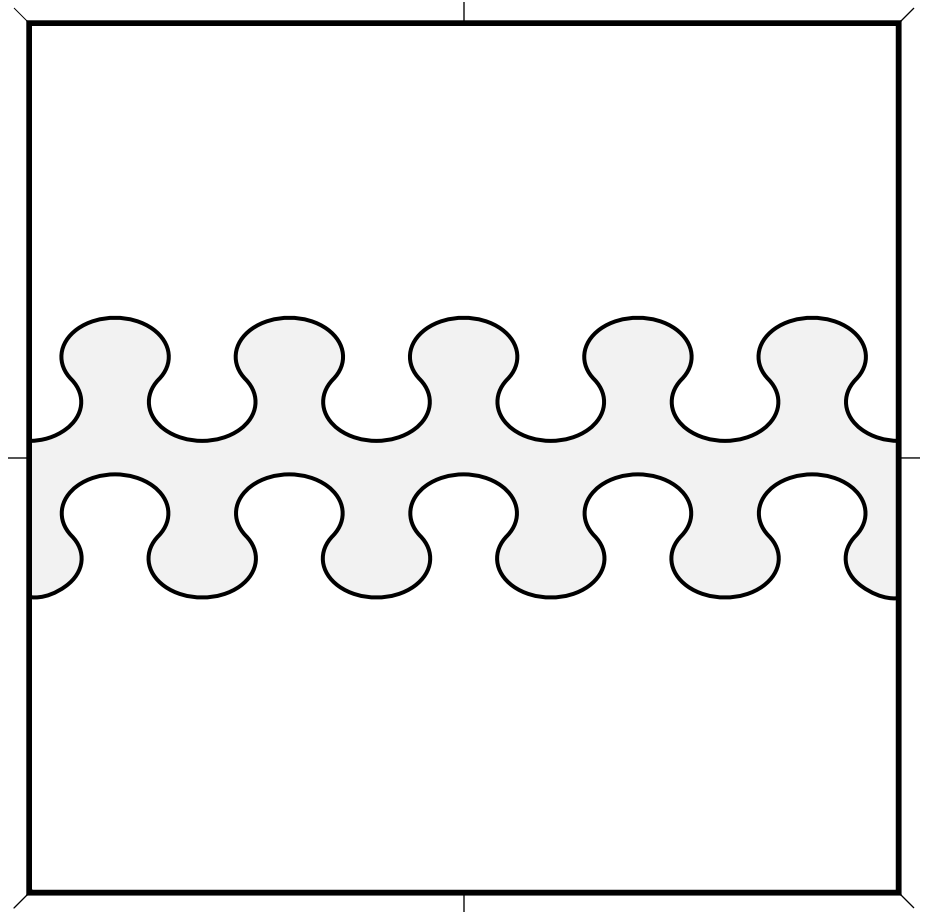
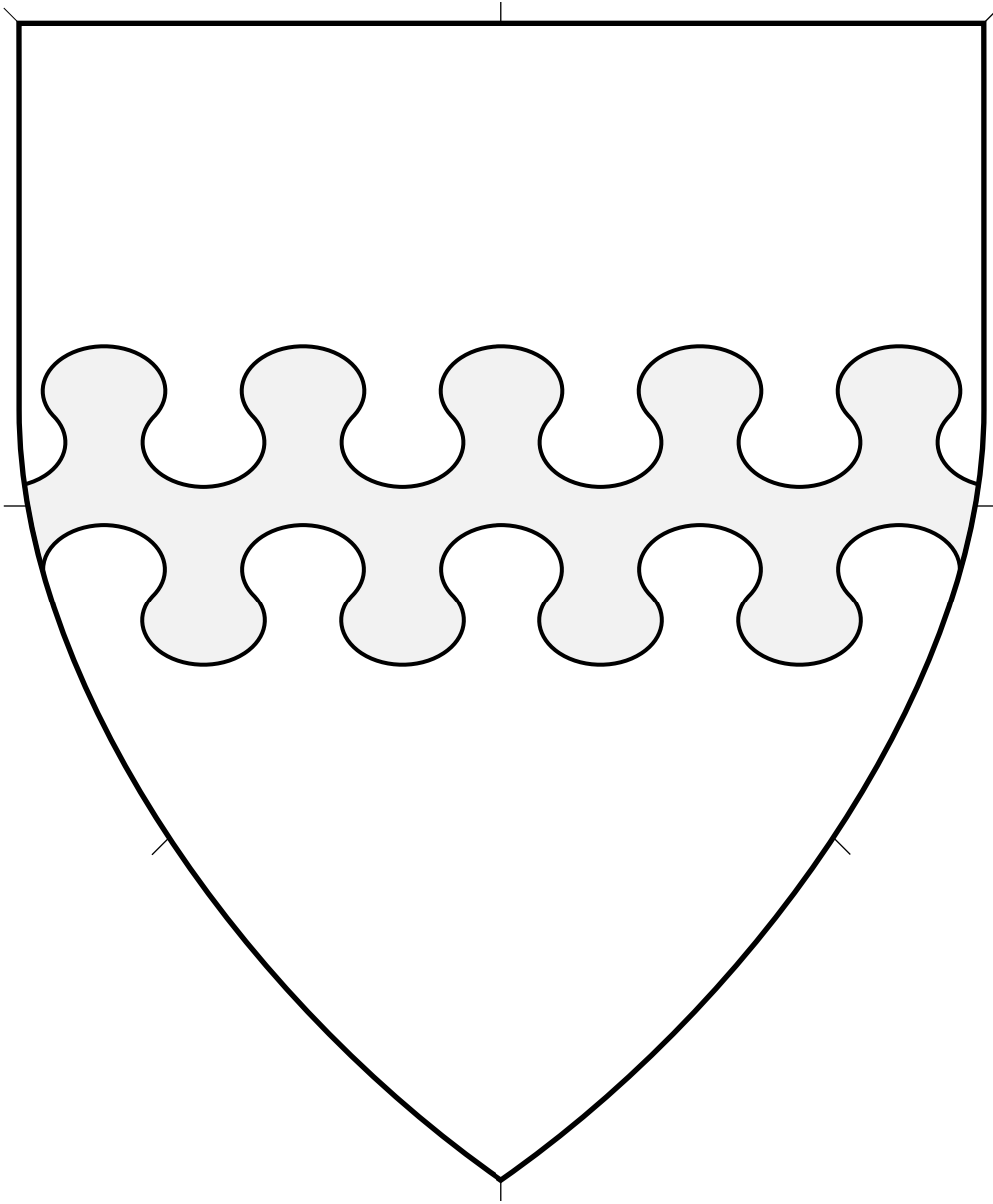

Central ordinary.

Source: Insignia Anglica. Artist unknown.

Fess Nebuly (3) • 4.429

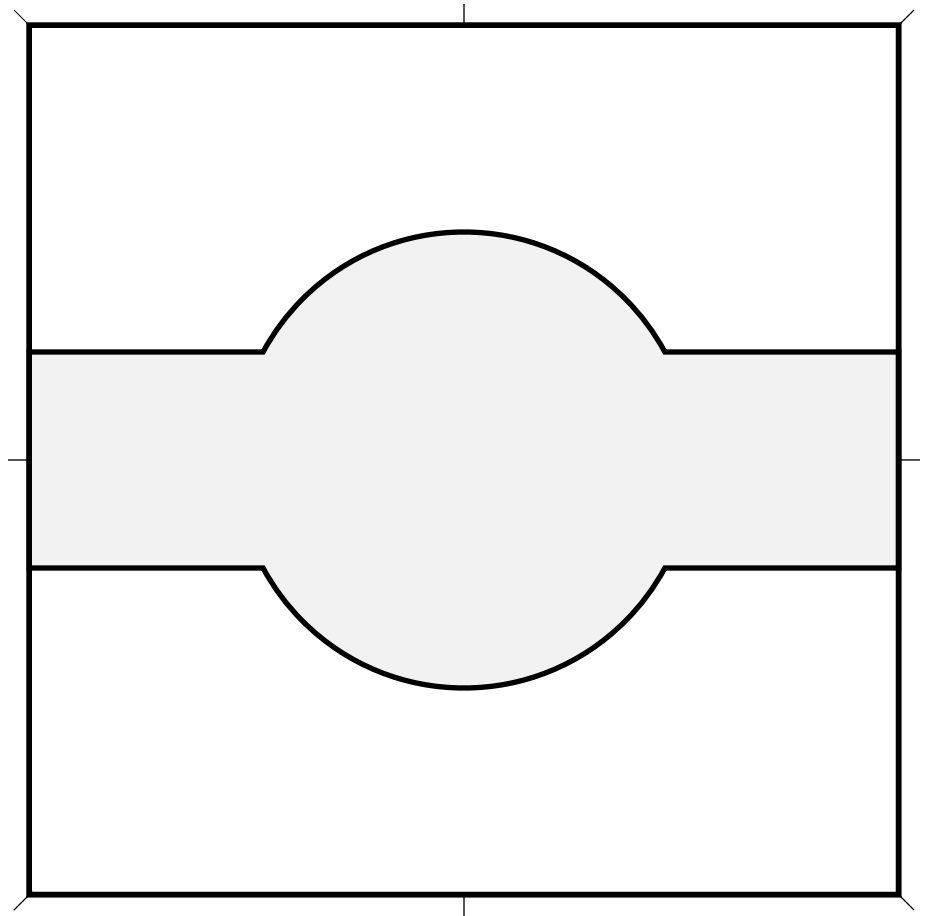
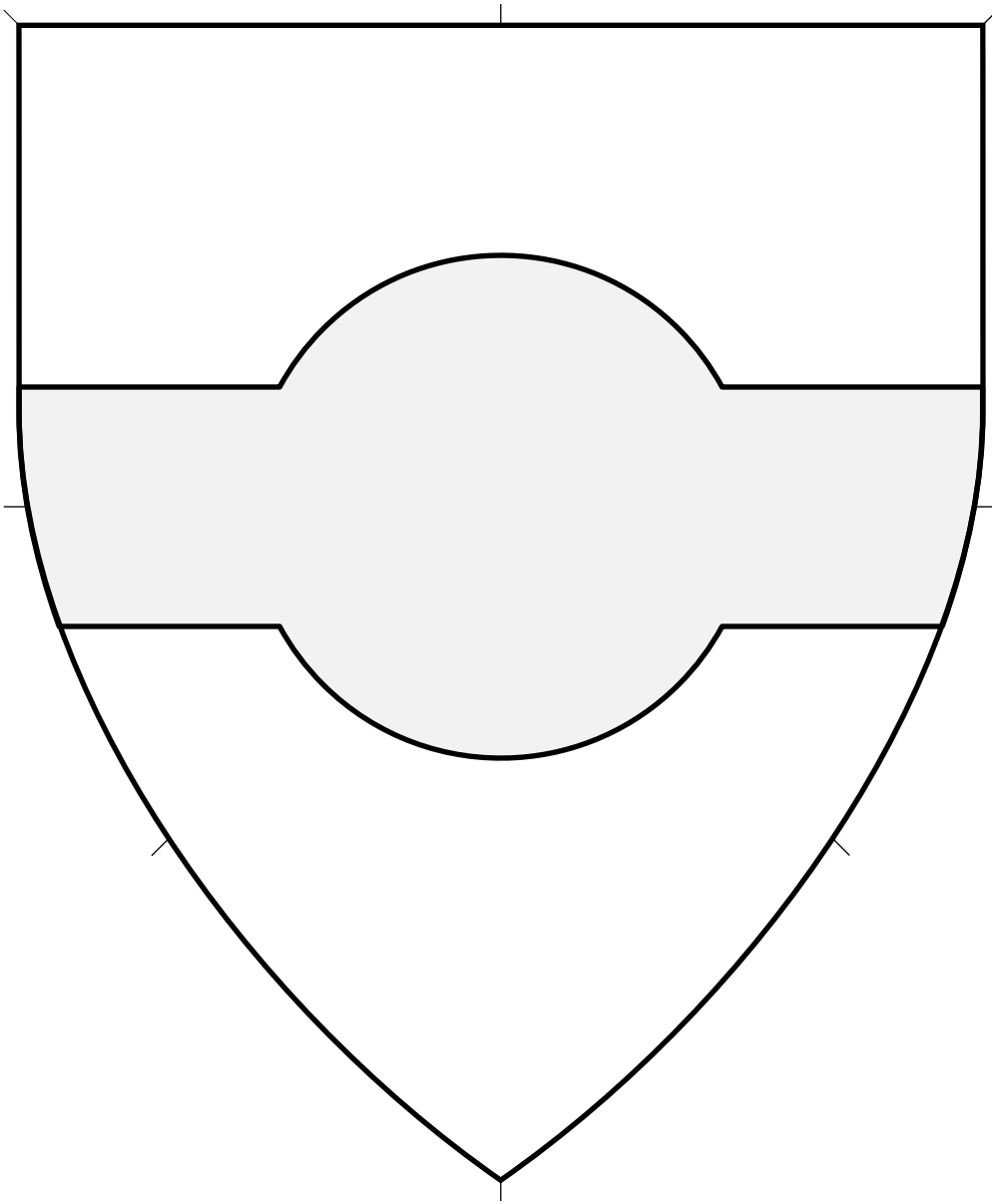

Central ordinary.

Fess Nowy (1) 4.430

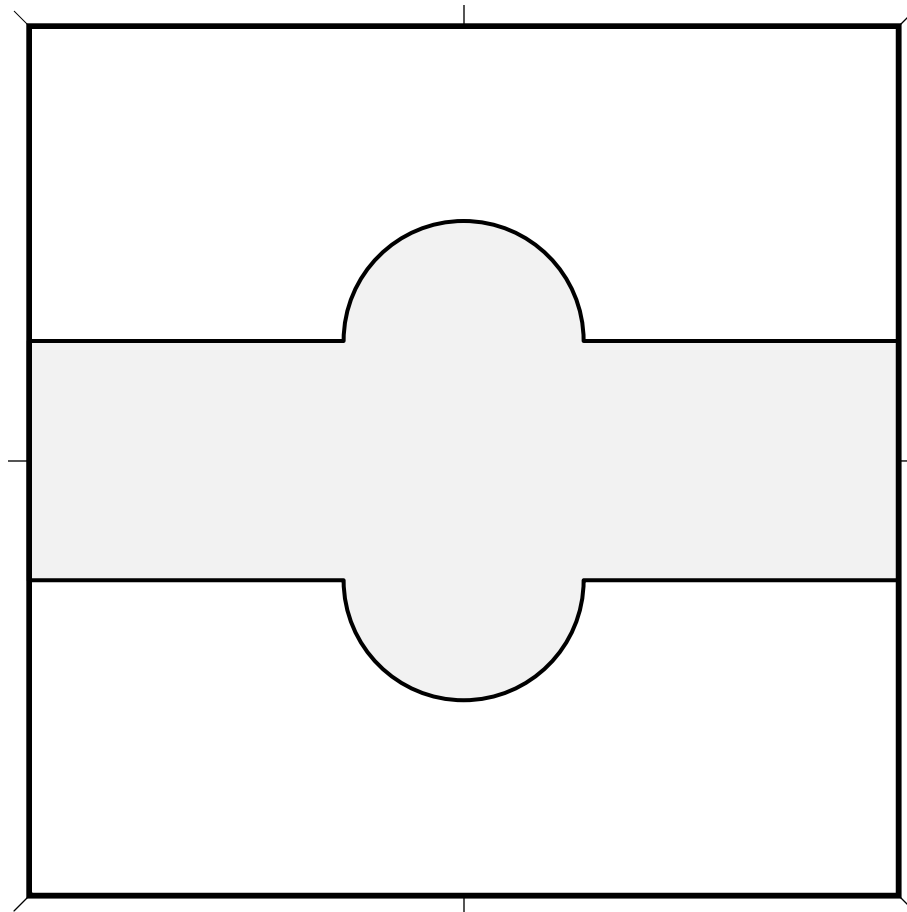
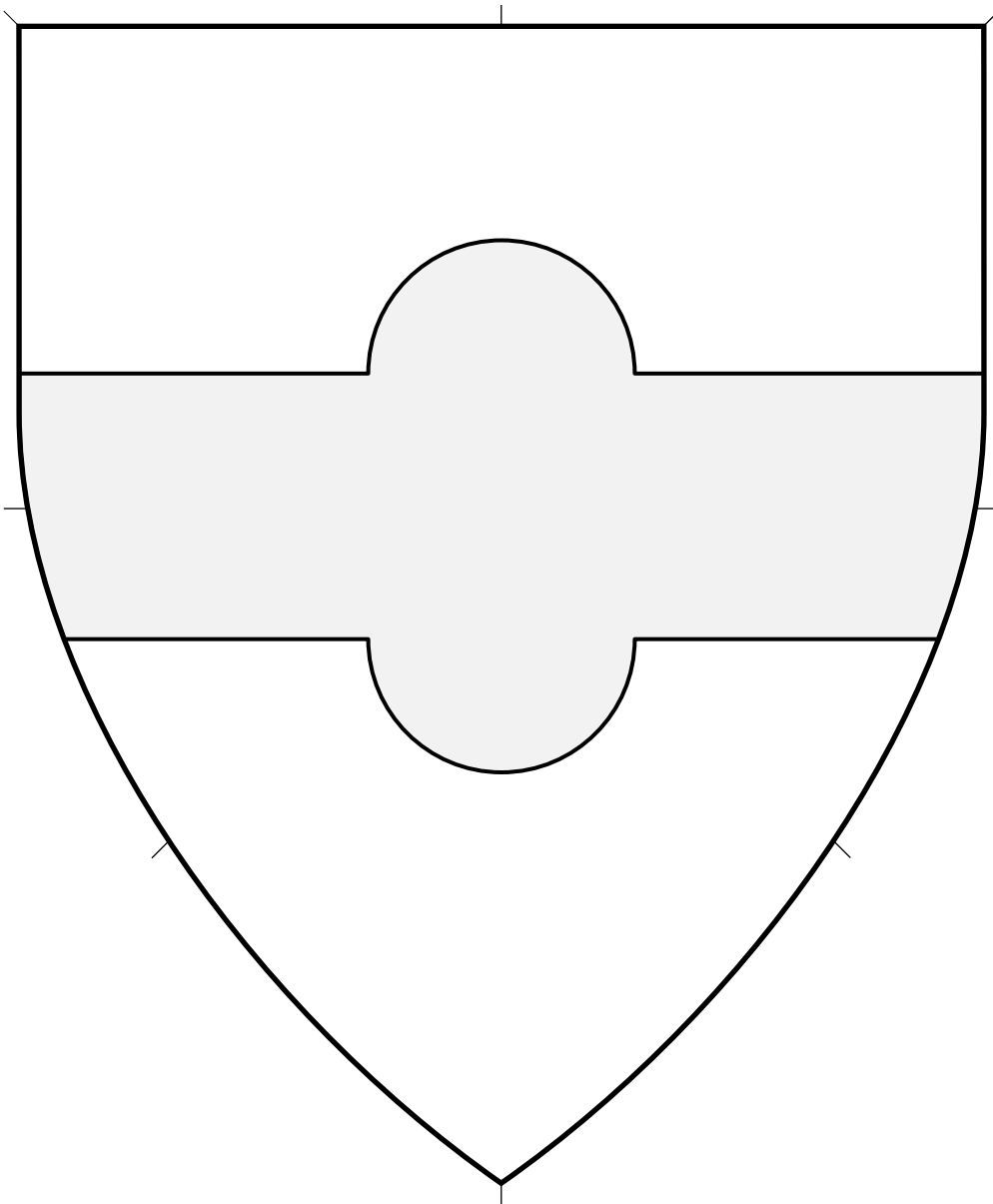

Central ordinary.

Source: Blasons de Bretagne. (Folio 74r.) Artist unknown.

Fess Nowy (2) 4.431

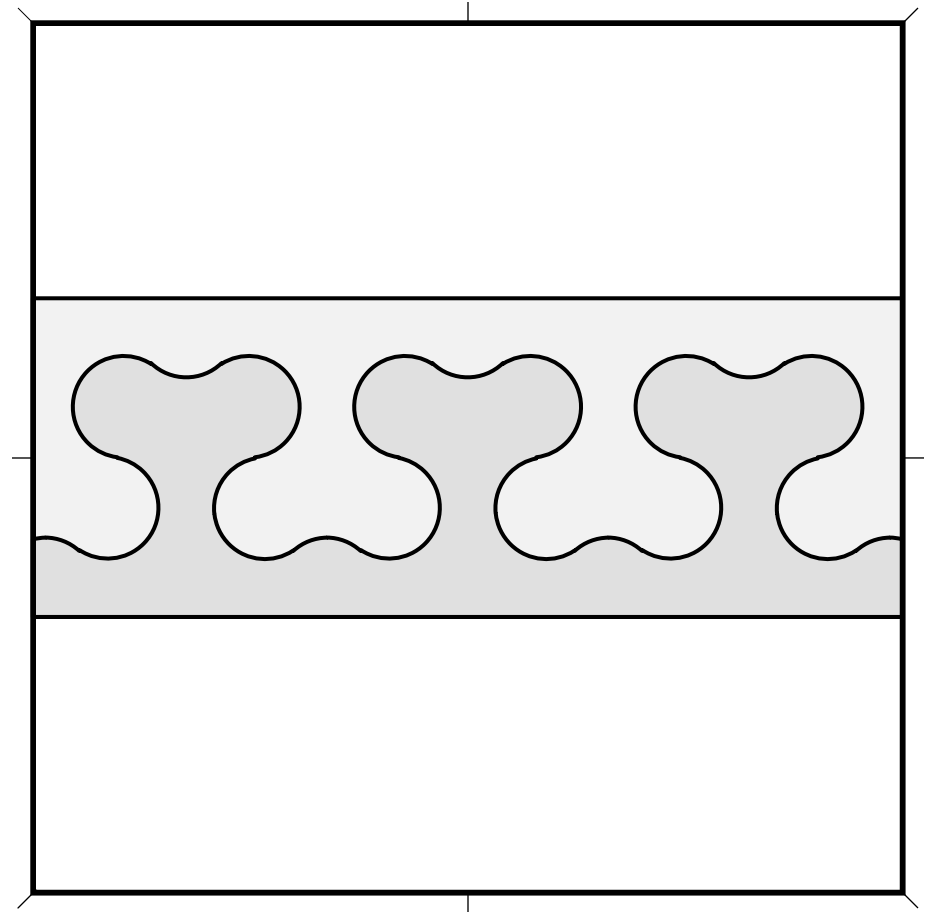
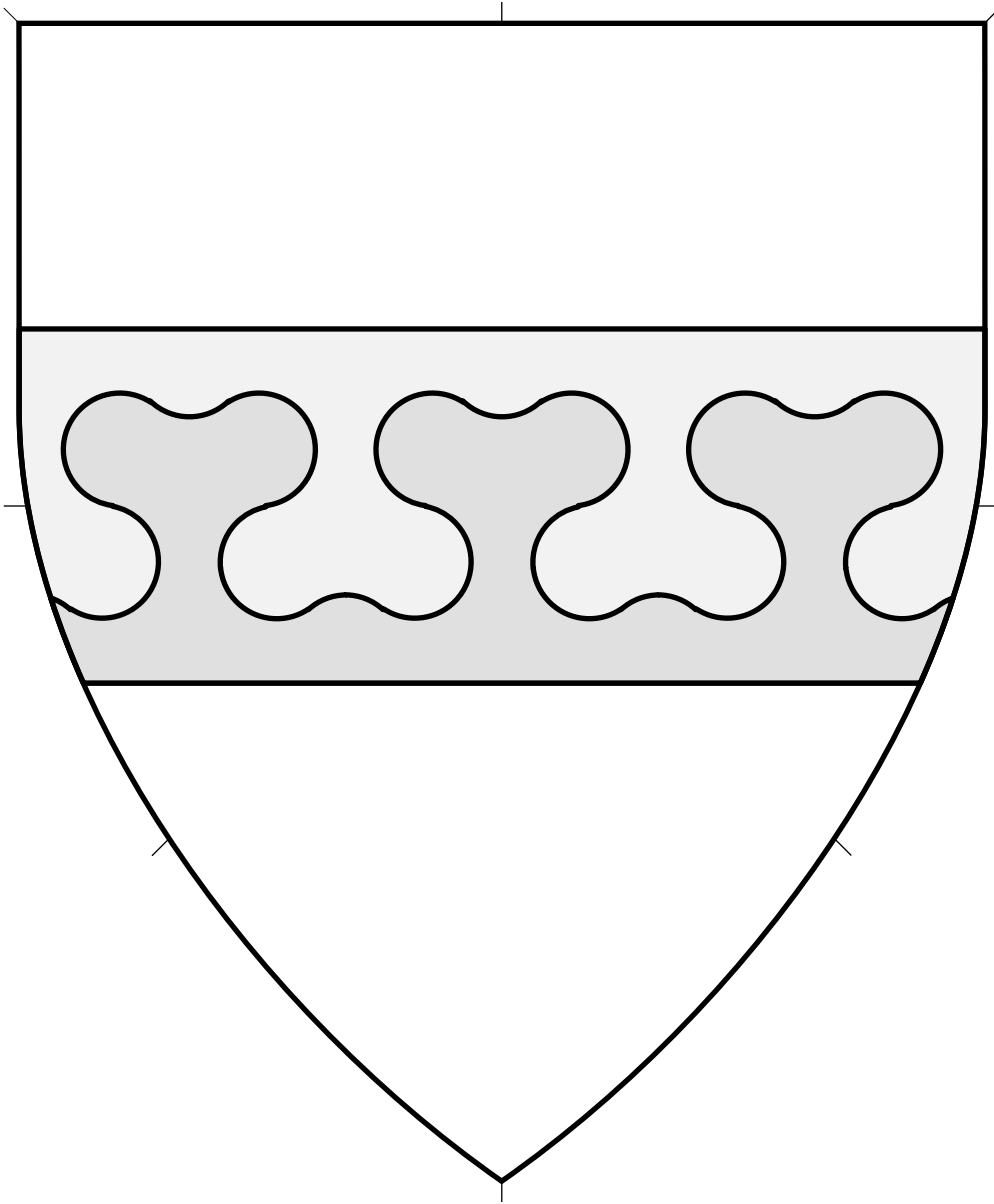

Central ordinary.

Source: Siebmacher's Wappenbuch of 1605. Artist: Johann Siebmacher.
(Arms of von Bastheim, plate 104.)

Fess Parted Nebuly 4.432

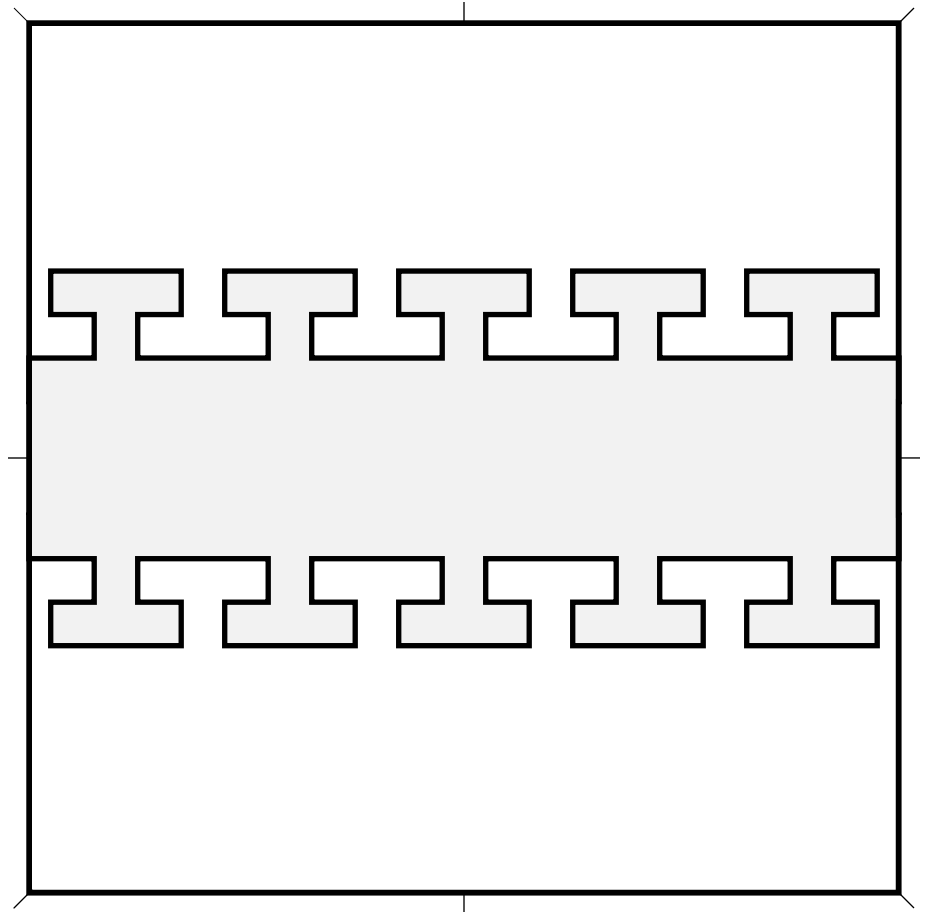
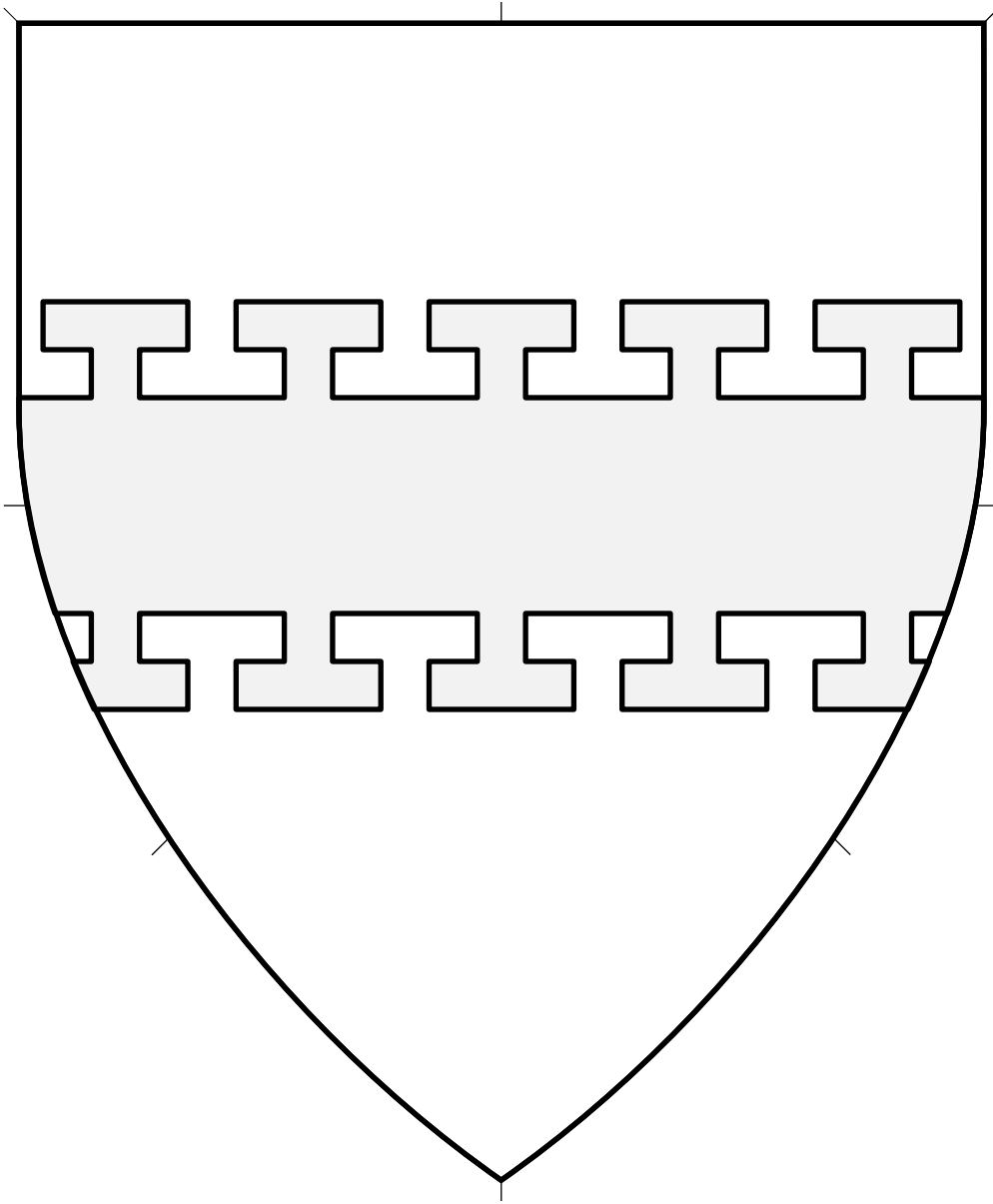

Central ordinary.

Fess Potency (1) 4.433

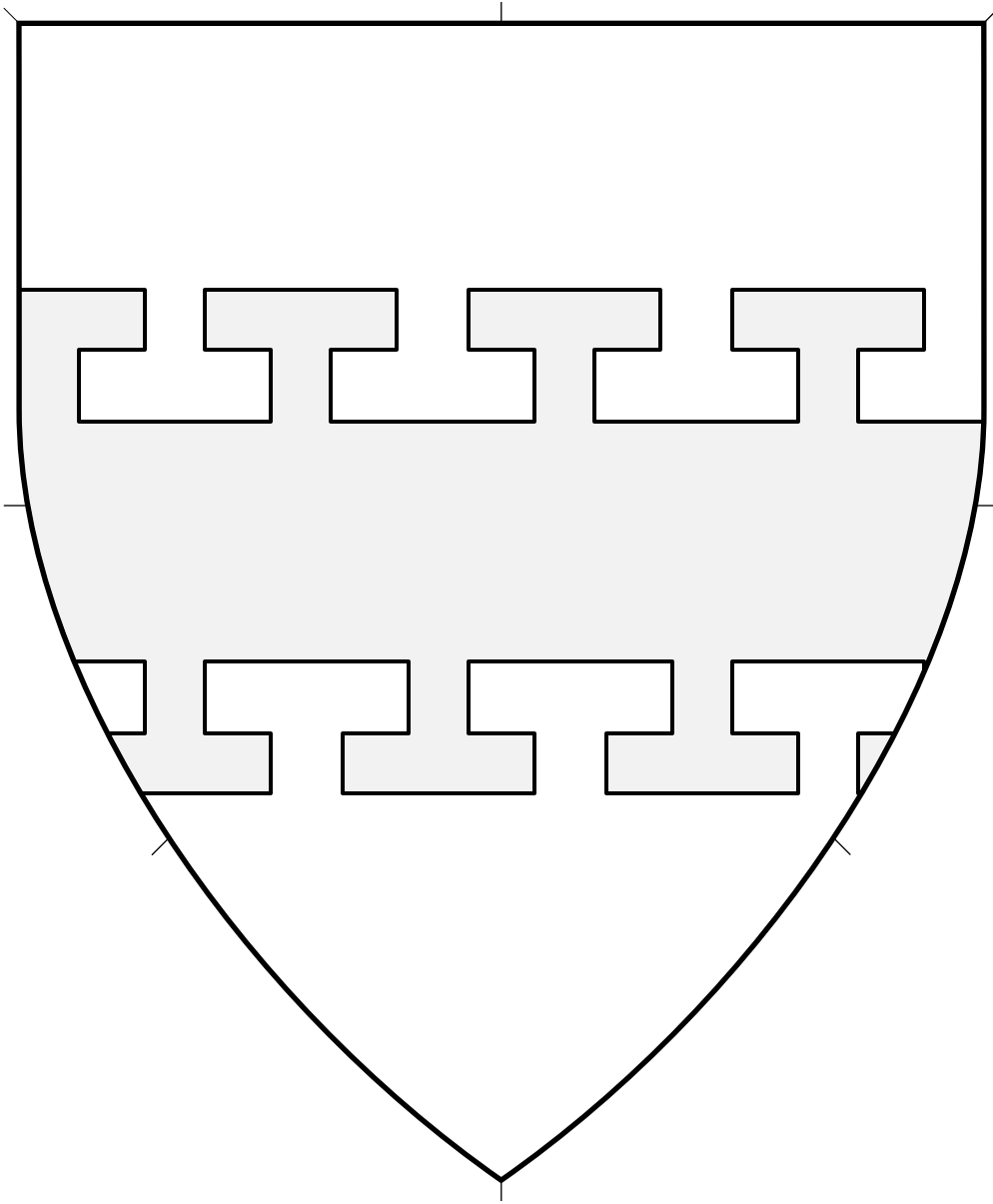

Central ordinary.

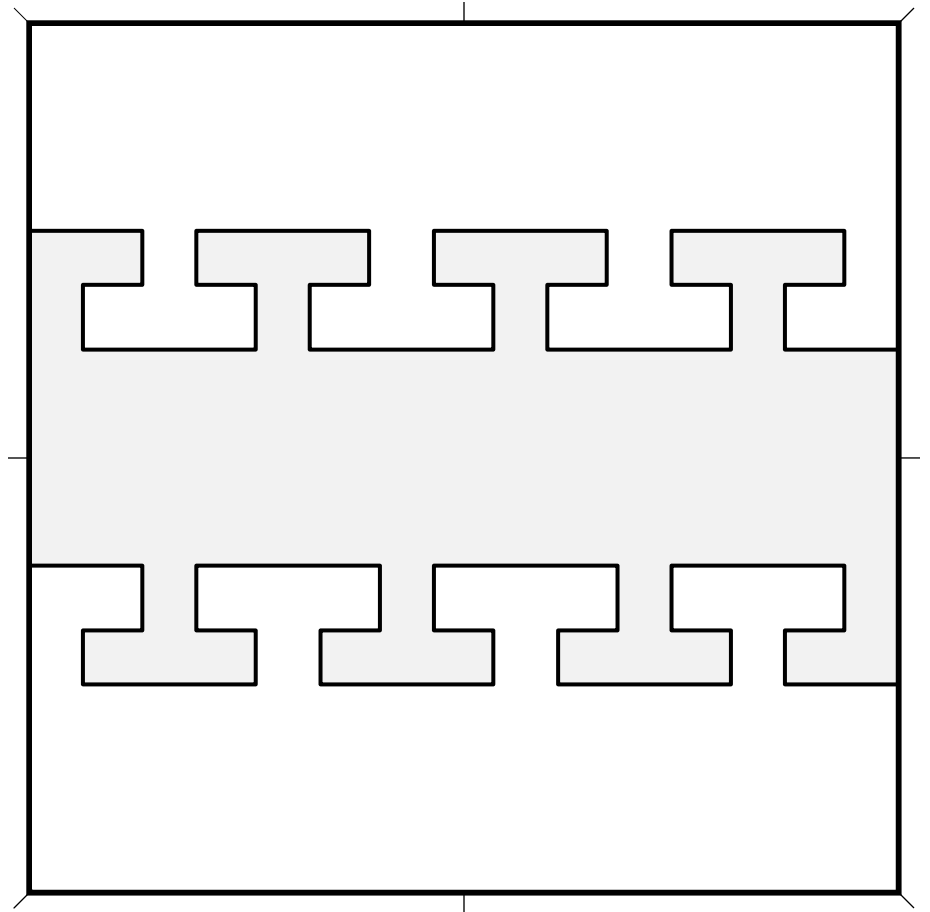

Fess Potenty (2) 4.434

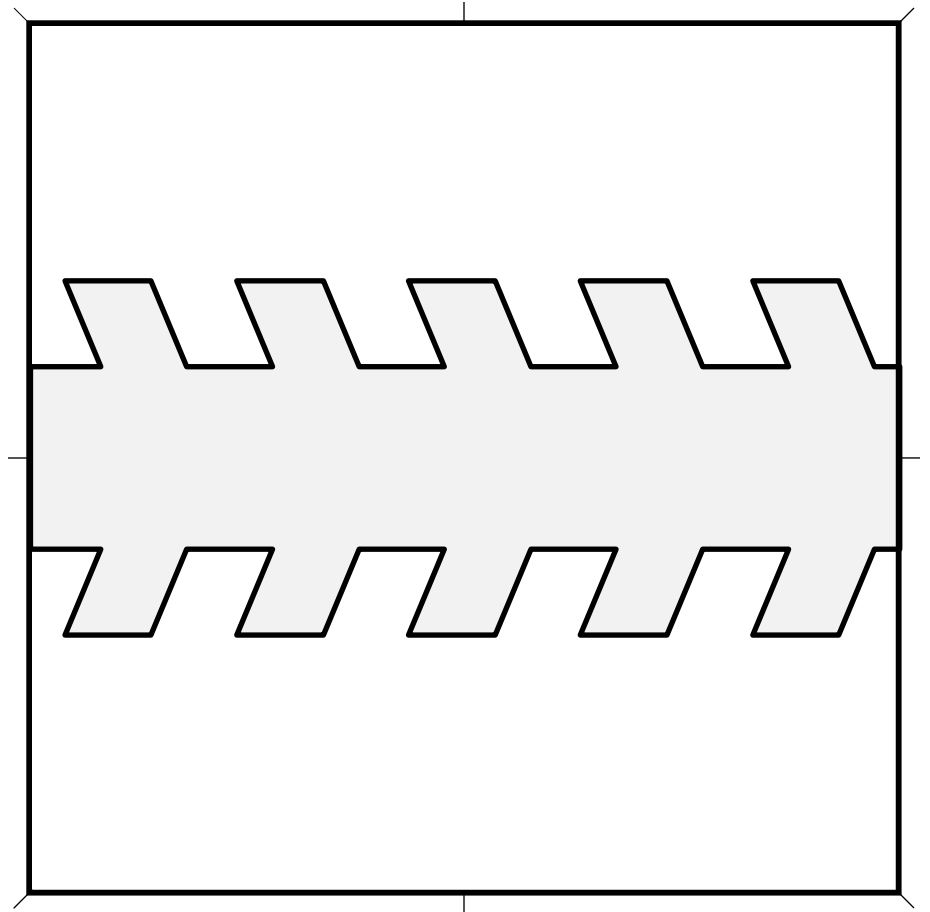
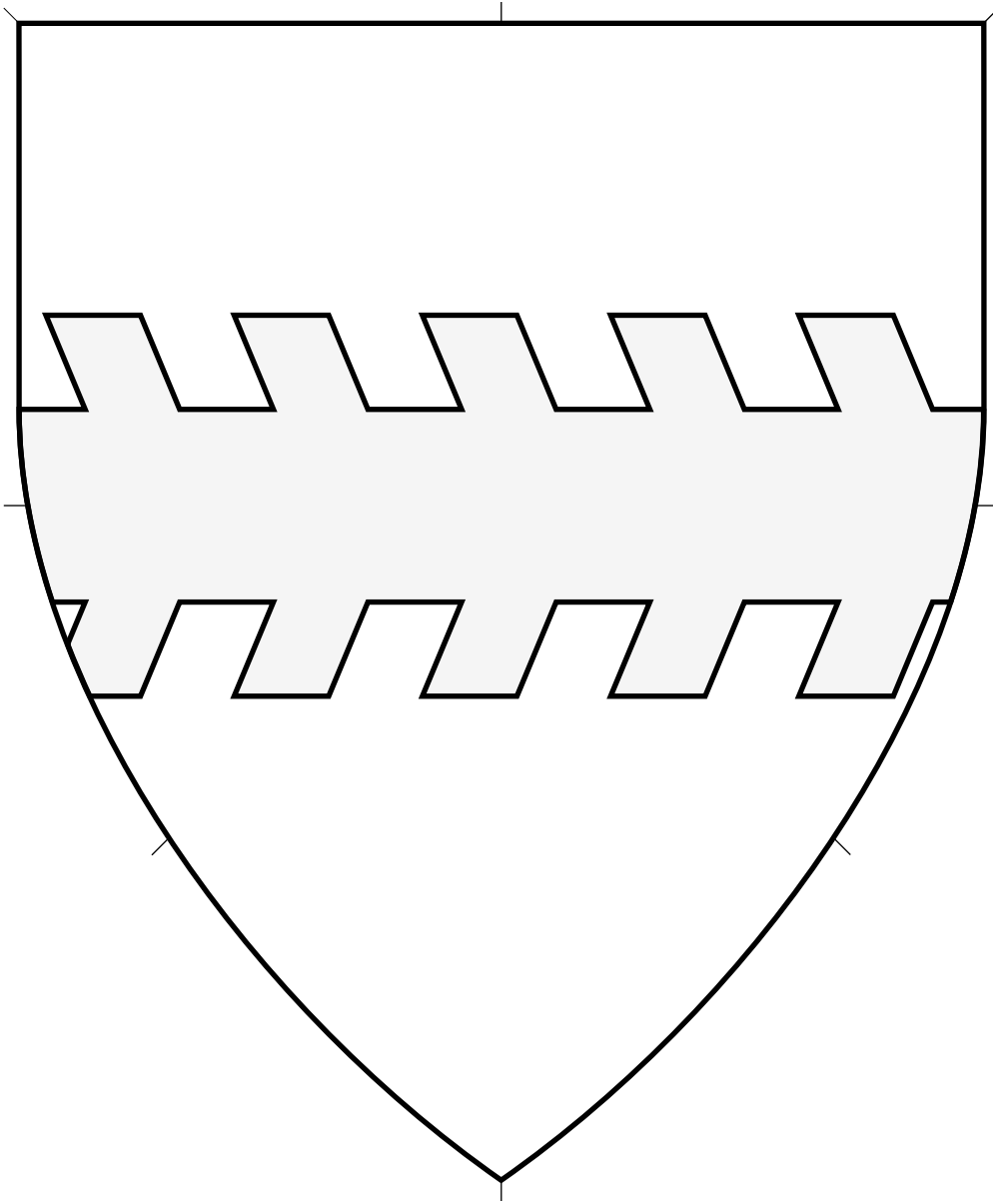

Central ordinary.

Fess Raguly (1) 4.435

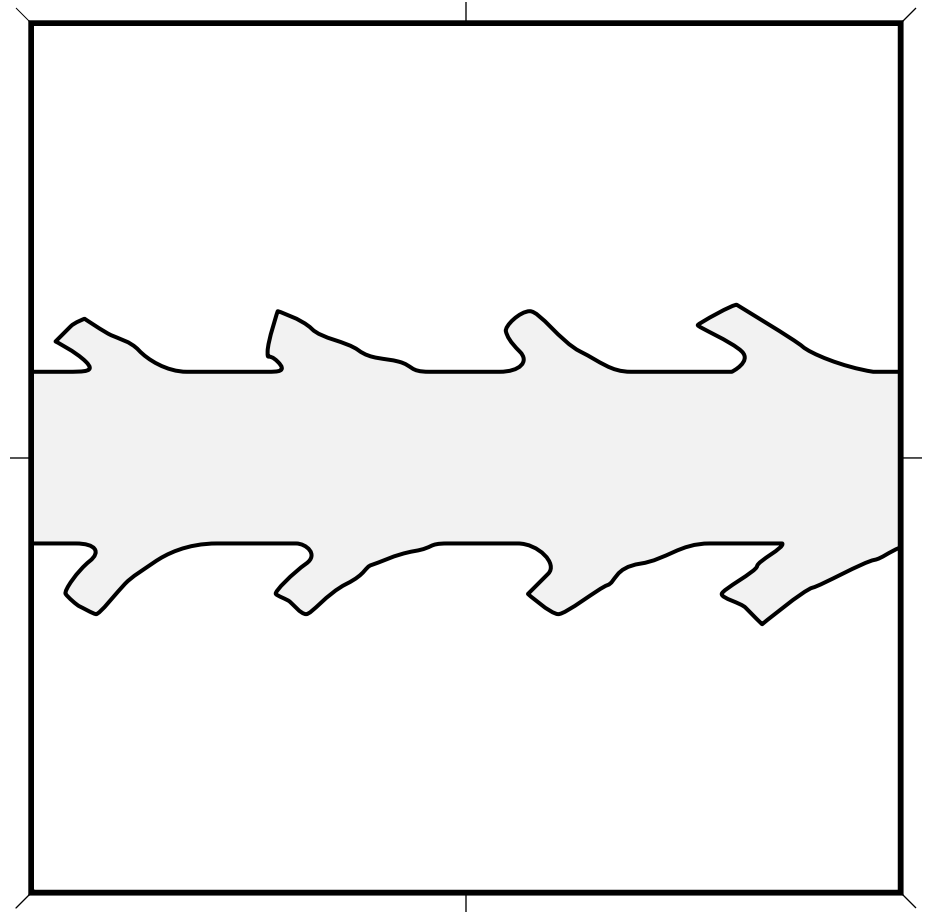
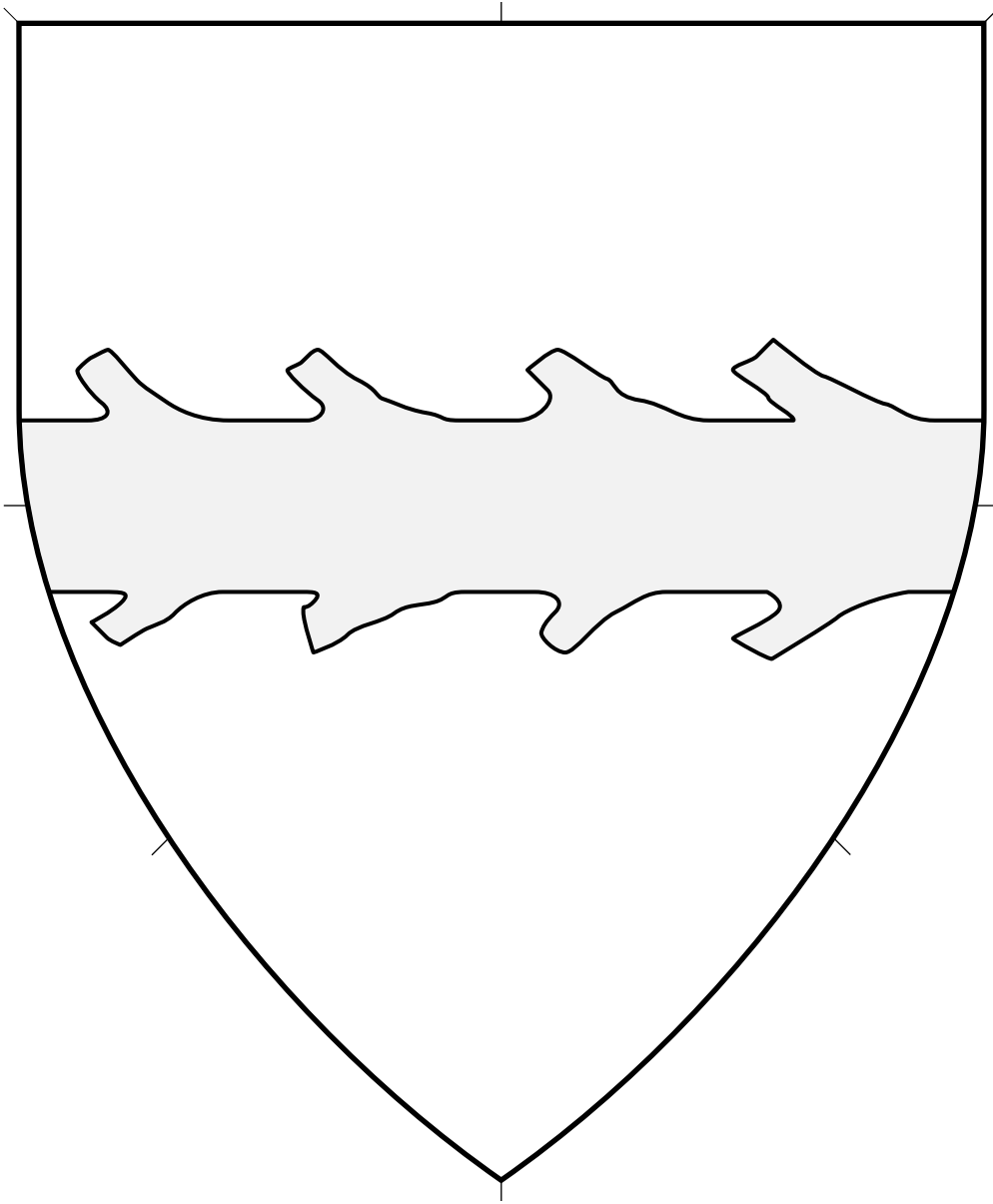

Central ordinary.

Source: Commonplace Book of Heraldry. (Folio 48v.)

Artist: Jean Faucket. Adapted by Mathghamhain Ua Ruadháin.

Fess Raguly (2) 4.436

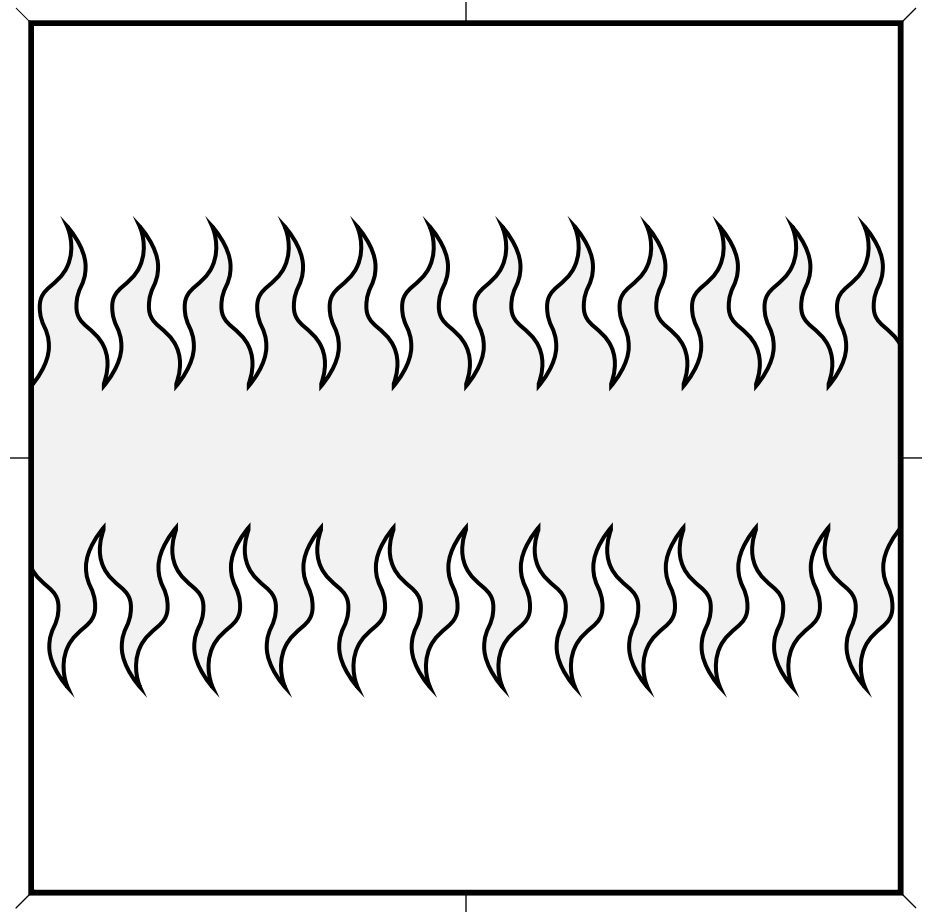
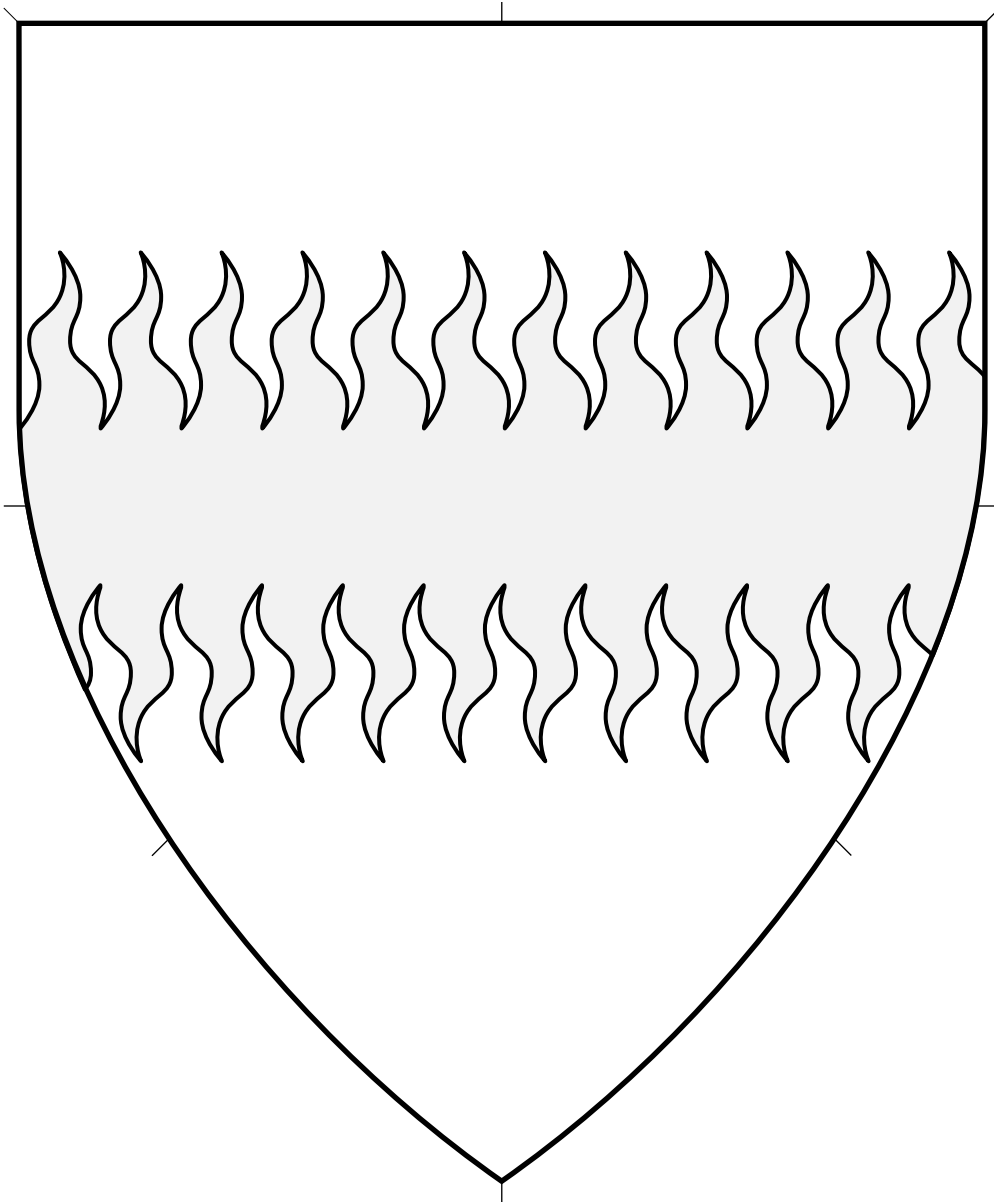

Central ordinary.

Fess Rayonny (1) 4.437

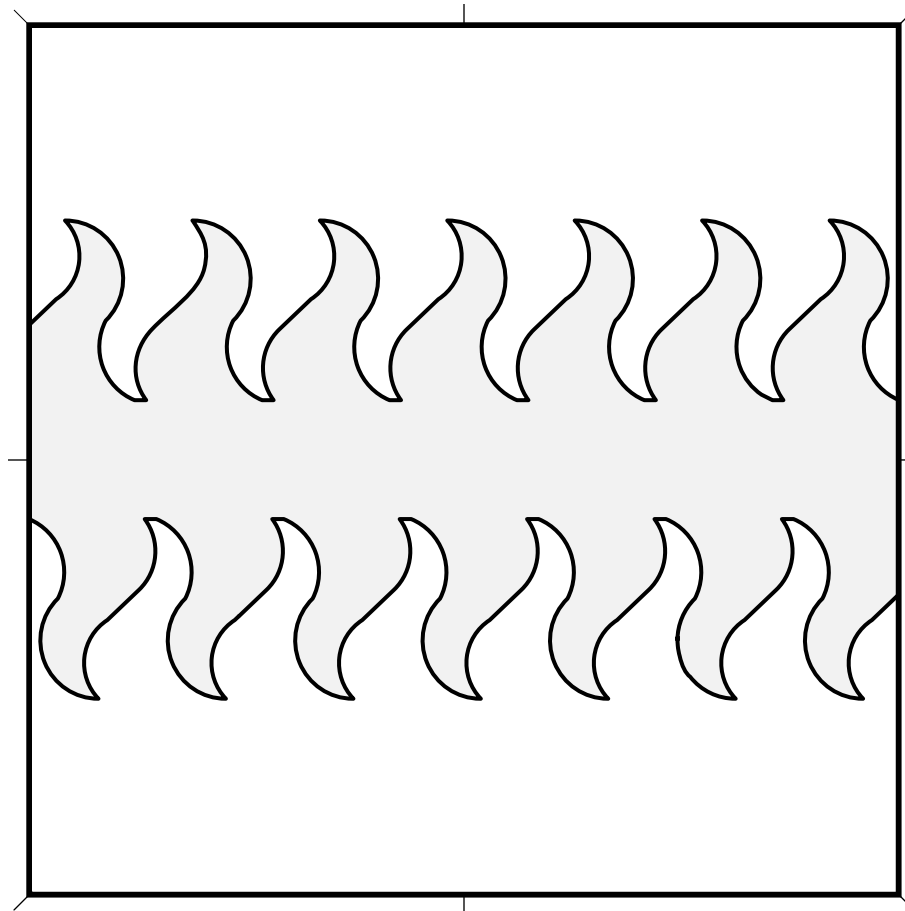
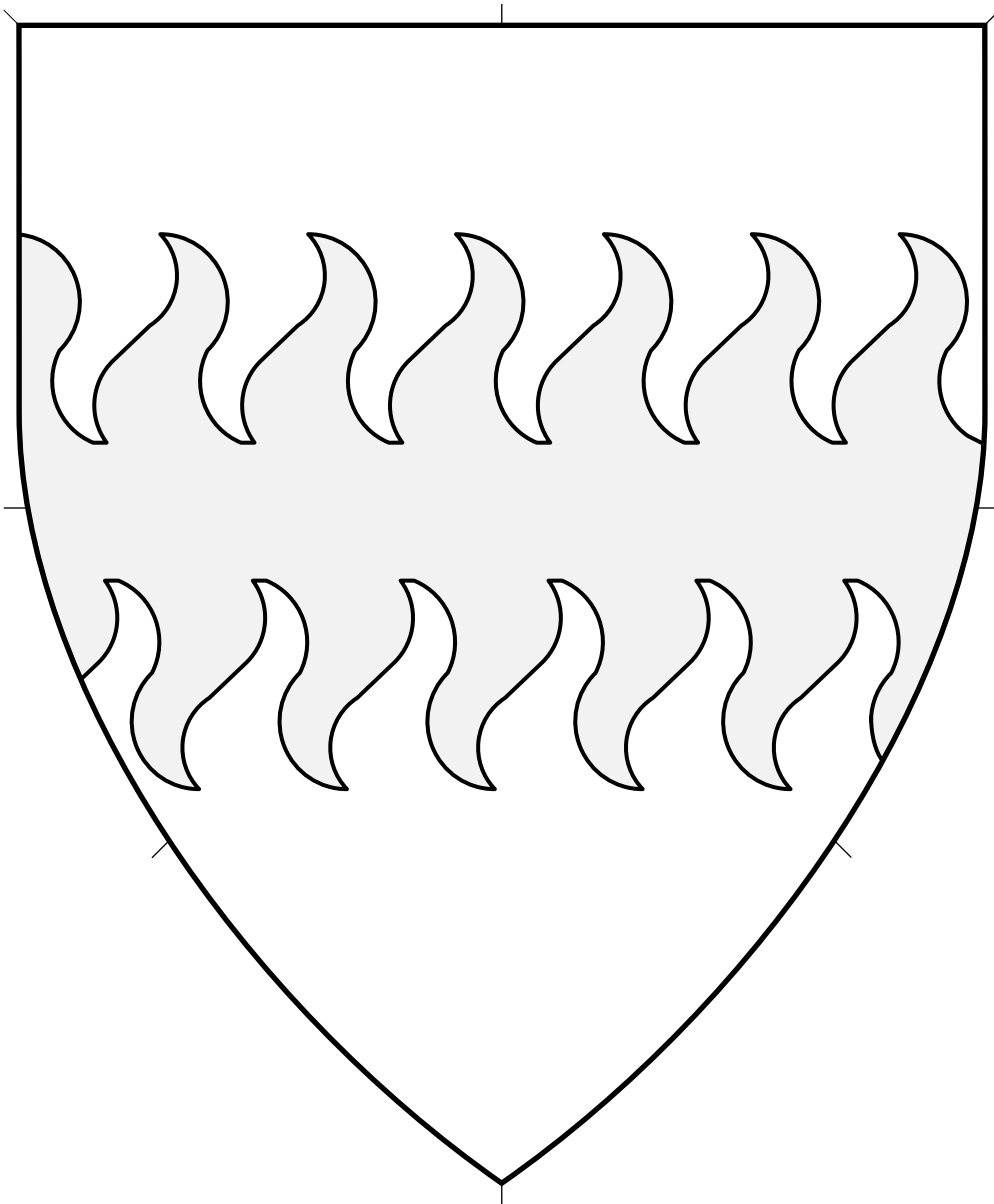

Central ordinary.

Source: Viking Answer Lady SVG Images For Heraldry.
Artist: Gunnvôr silfrahárr. Adapted by Mathghamhain Ua Ruadháin.

Fess Rayonny (2) 4.438

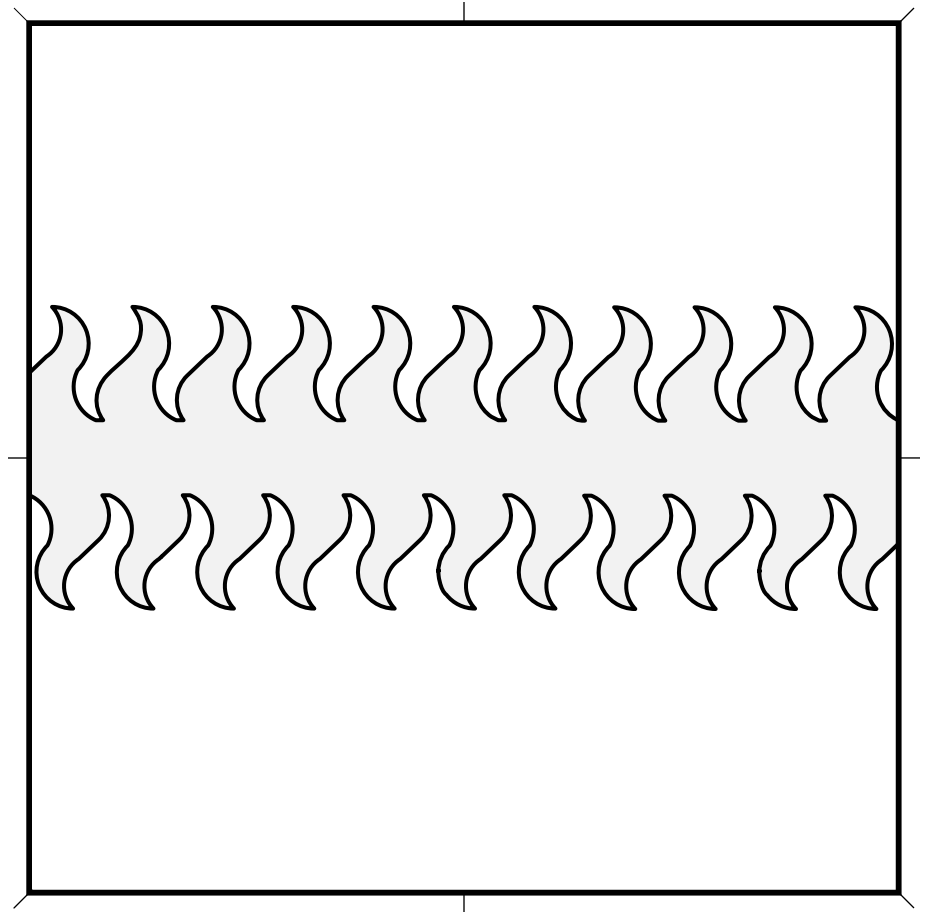
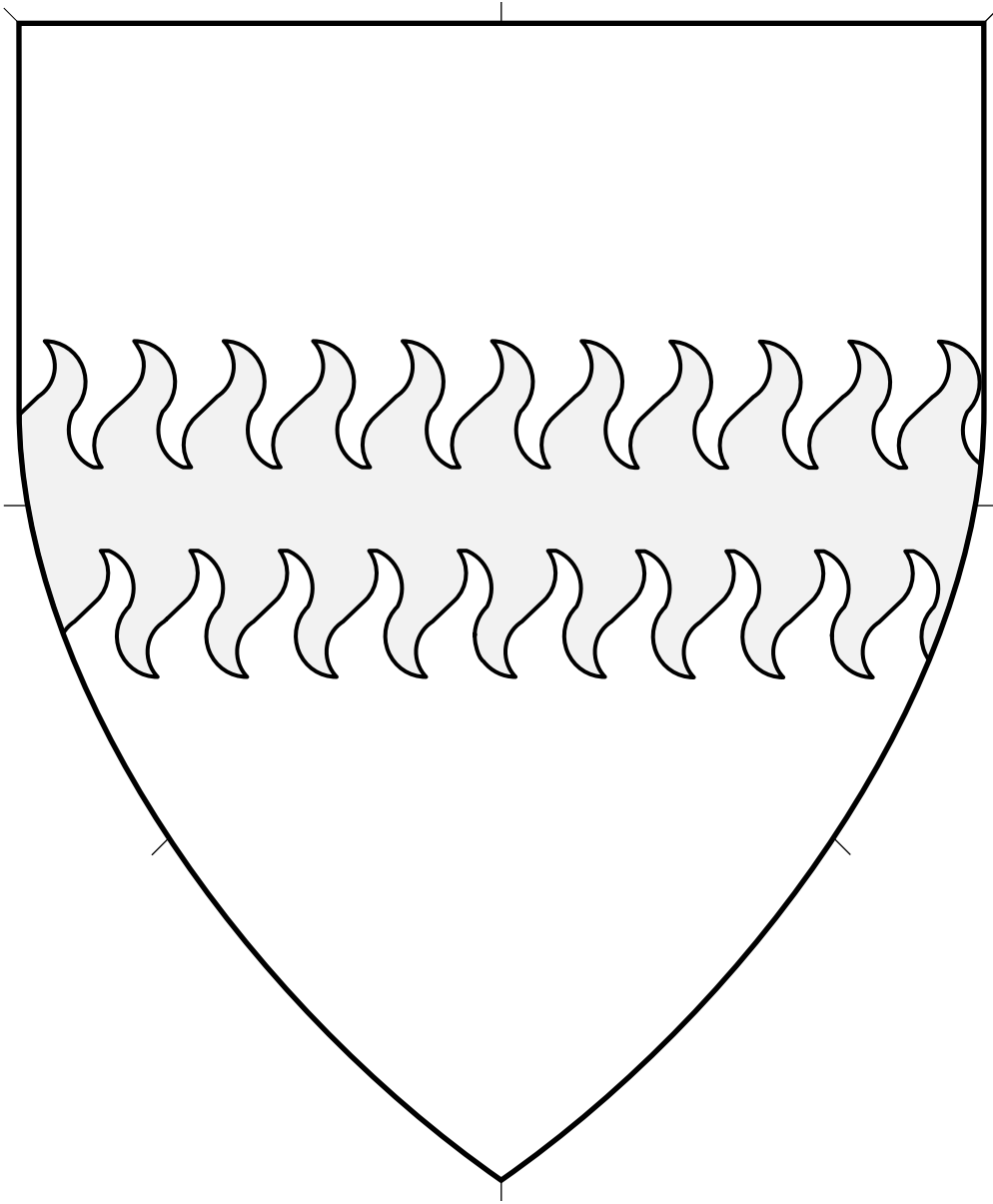

Central ordinary.

Source: Viking Answer Lady SVG Images For Heraldry.
Artist: Gunnvôr silfrahárr. Adapted by Mathghamhain Ua Ruadháin.

Fess Rayonny (3) 4.439

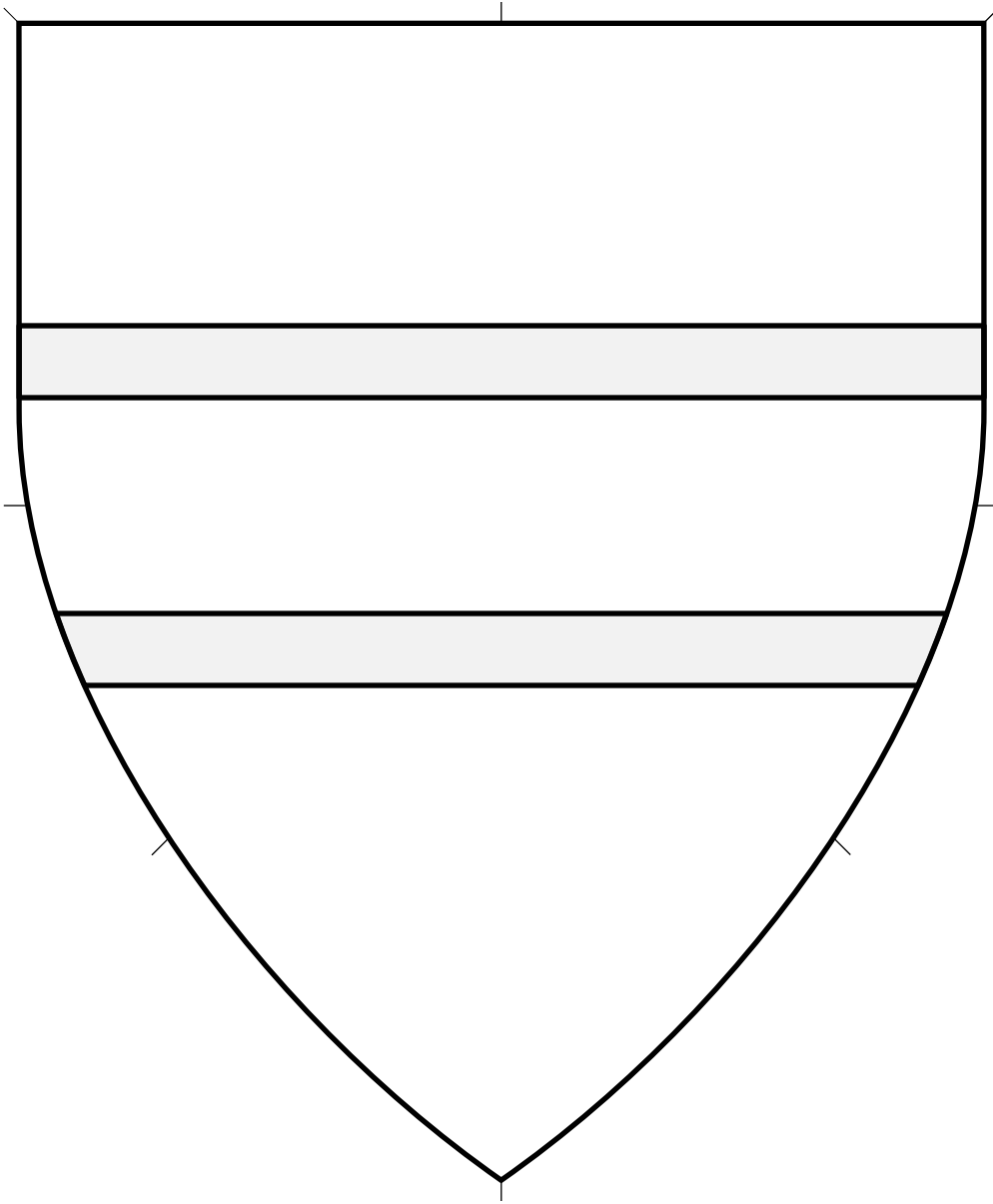

Central ordinary.

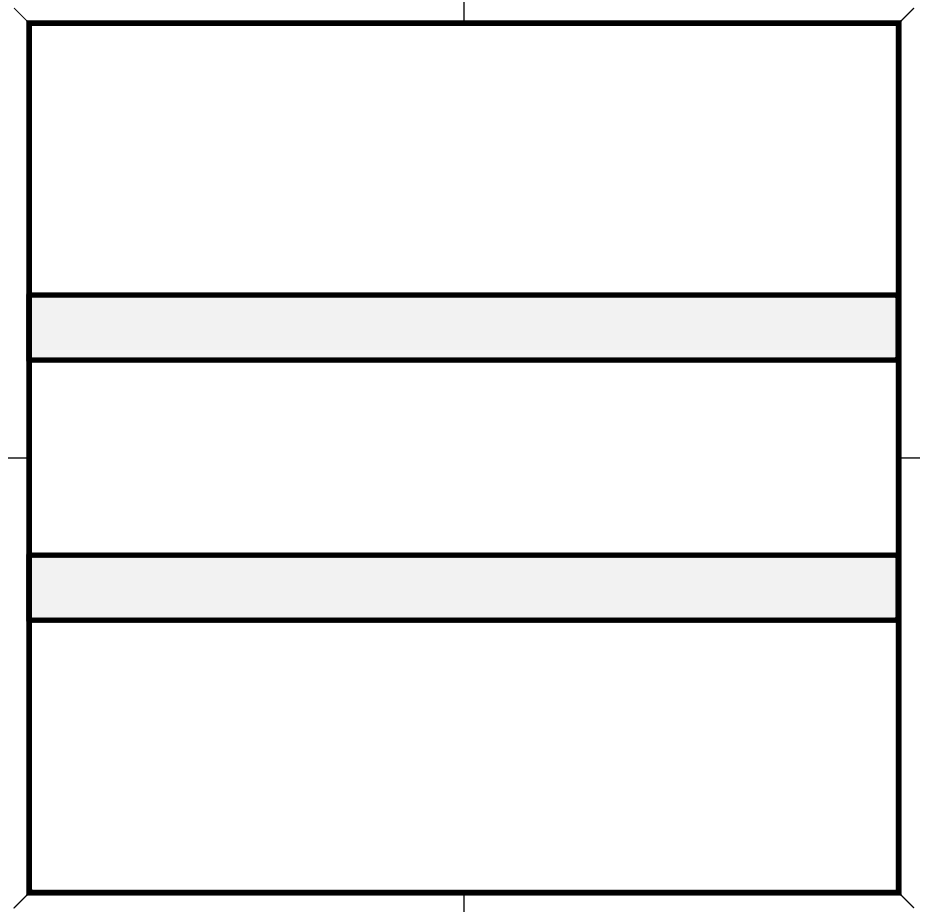

Fess Voided 4.440

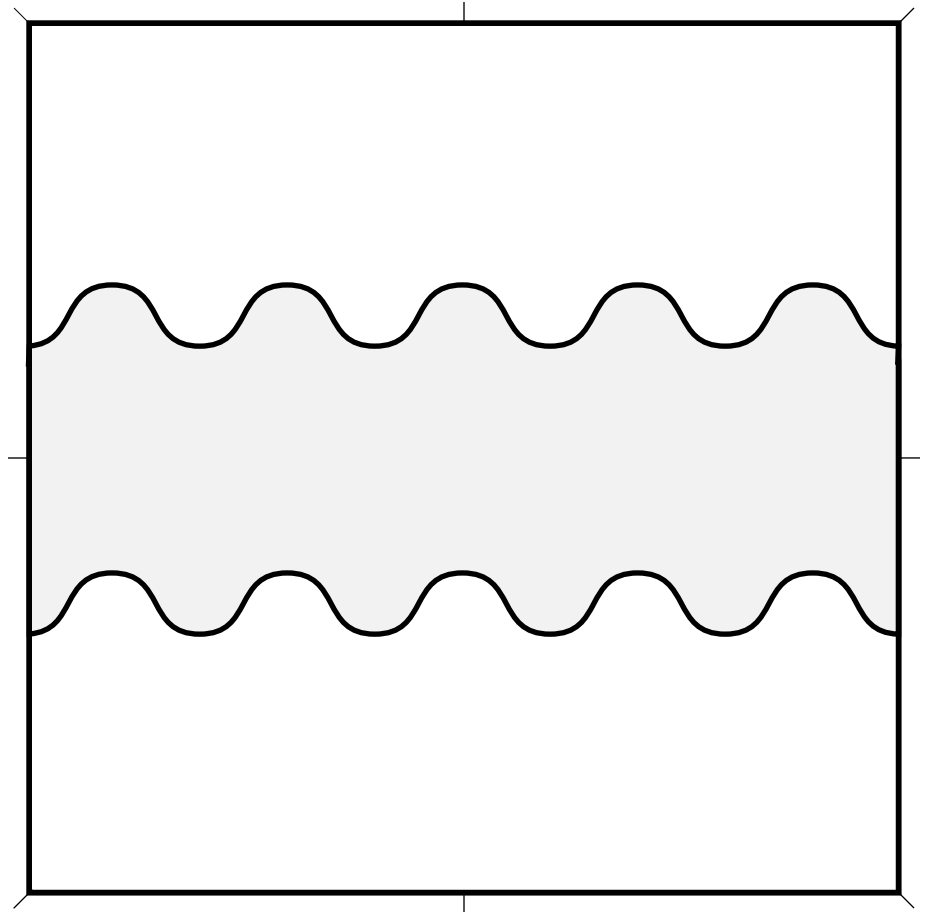
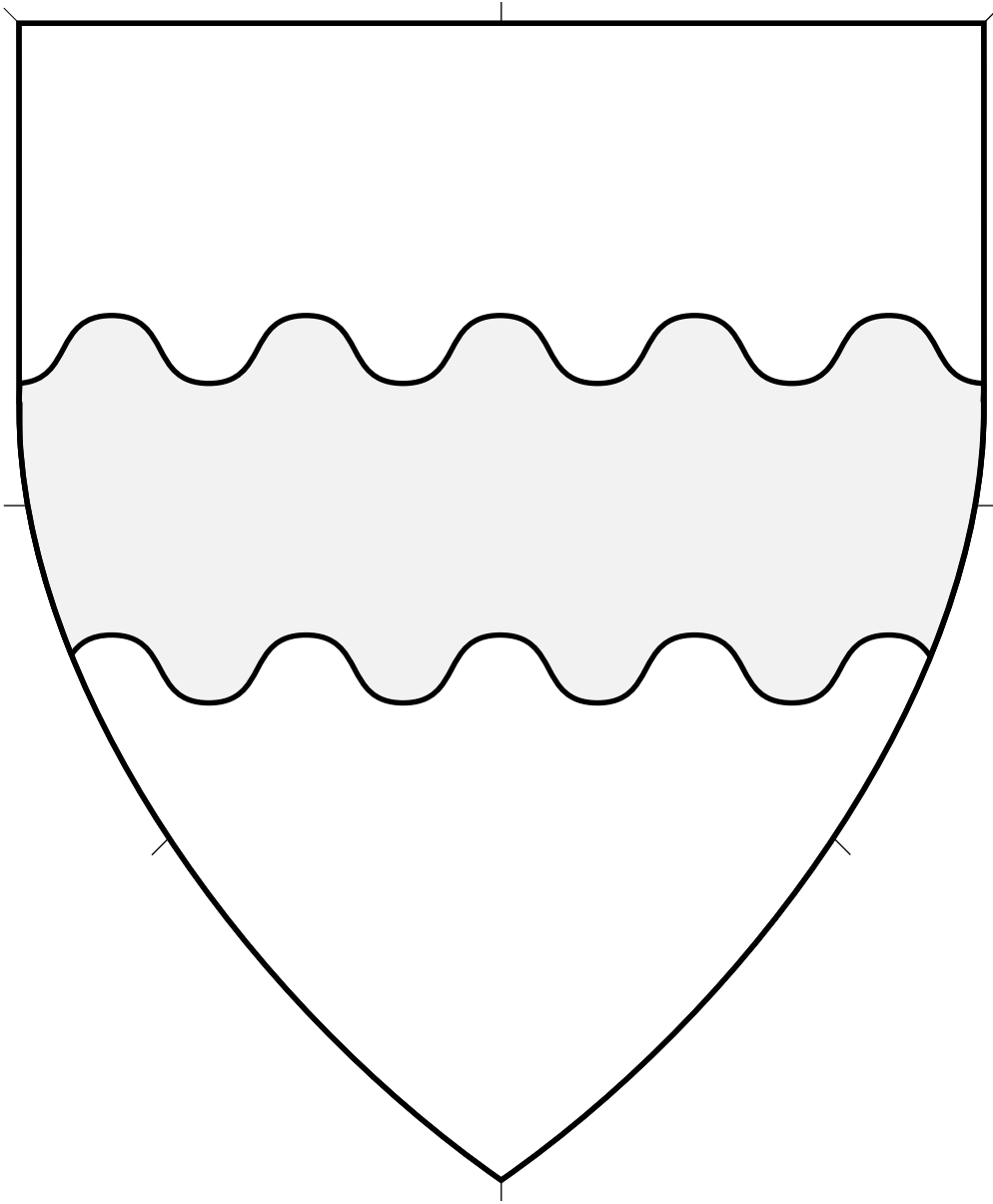

Central ordinary.

Fess Wavy (1) 4.441

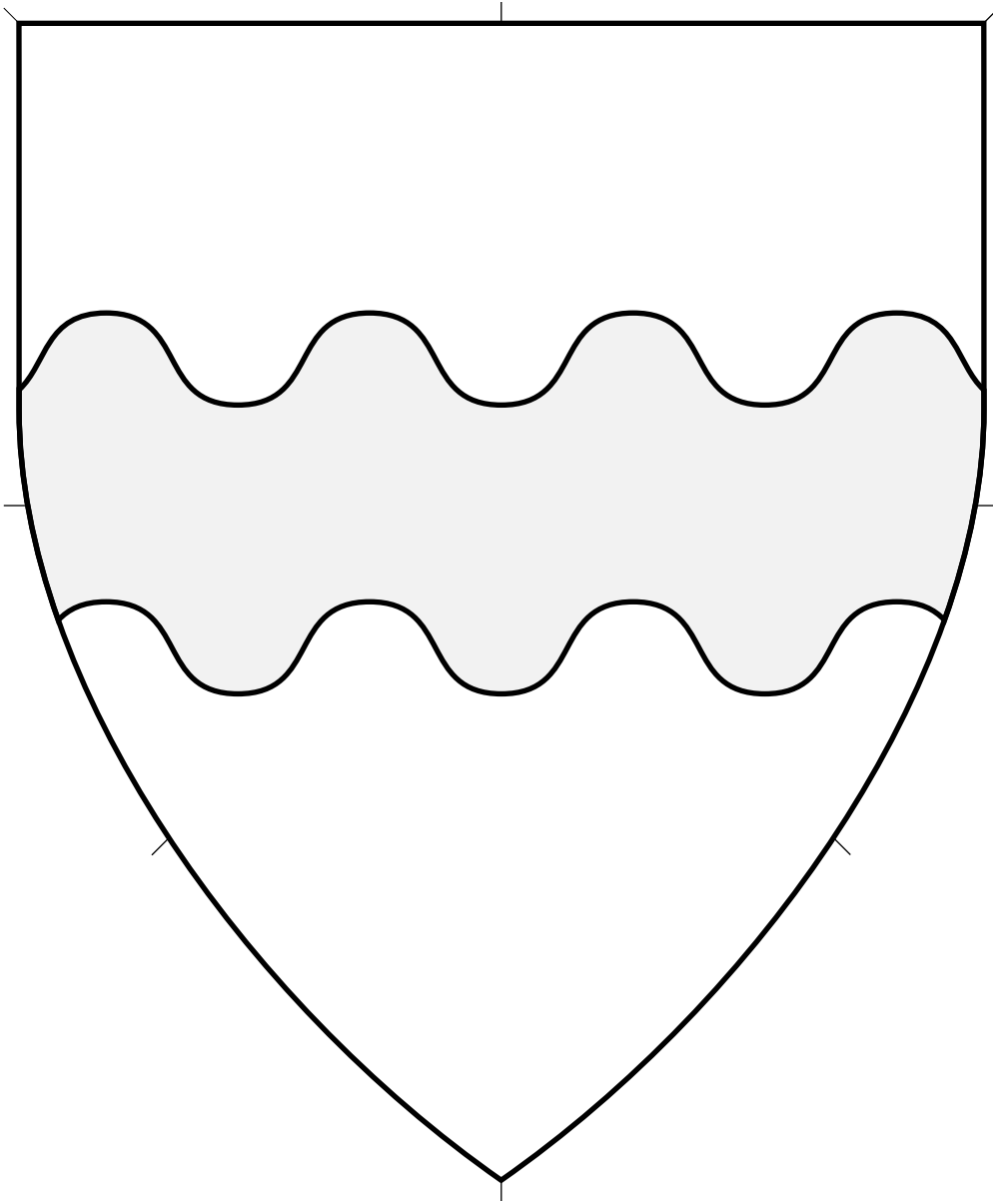

Central ordinary.

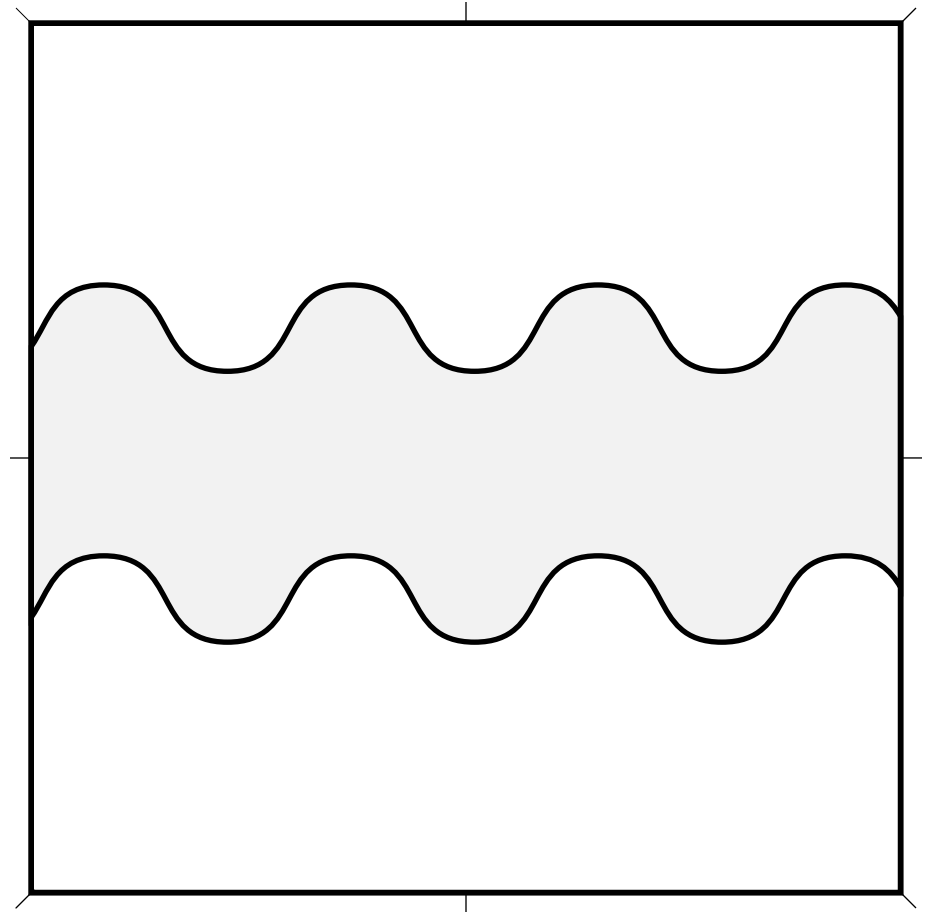

Fess Wavy (2) 4.442

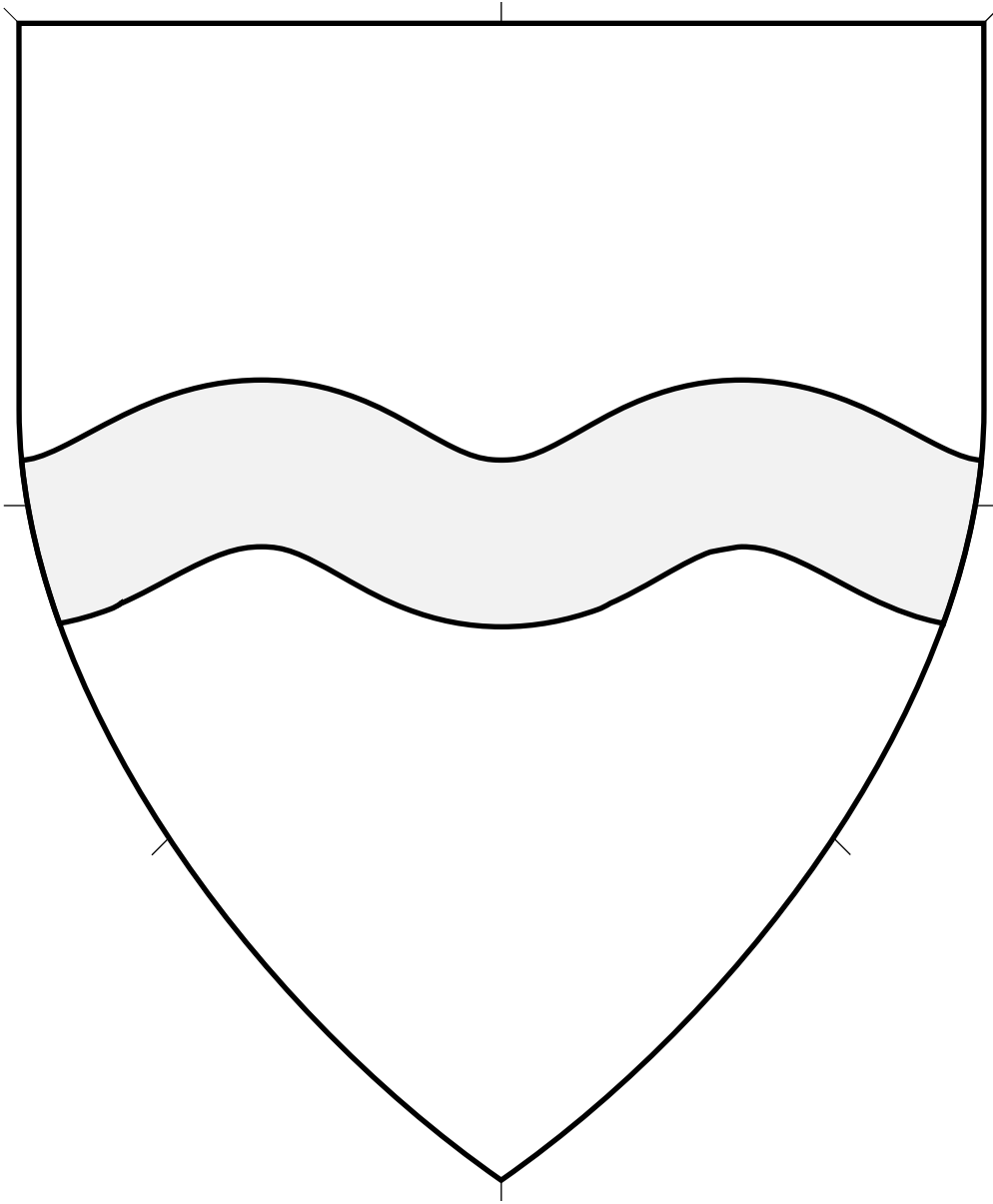

Central ordinary.

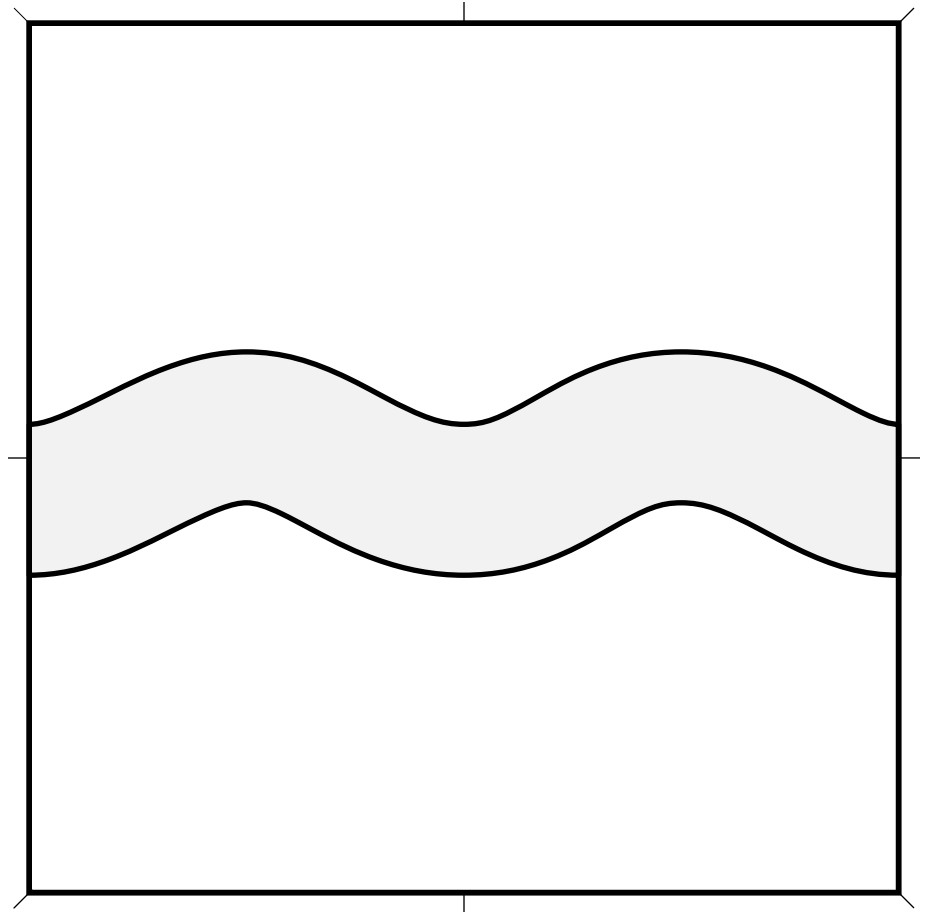

Fess Wavy (3) 4.443

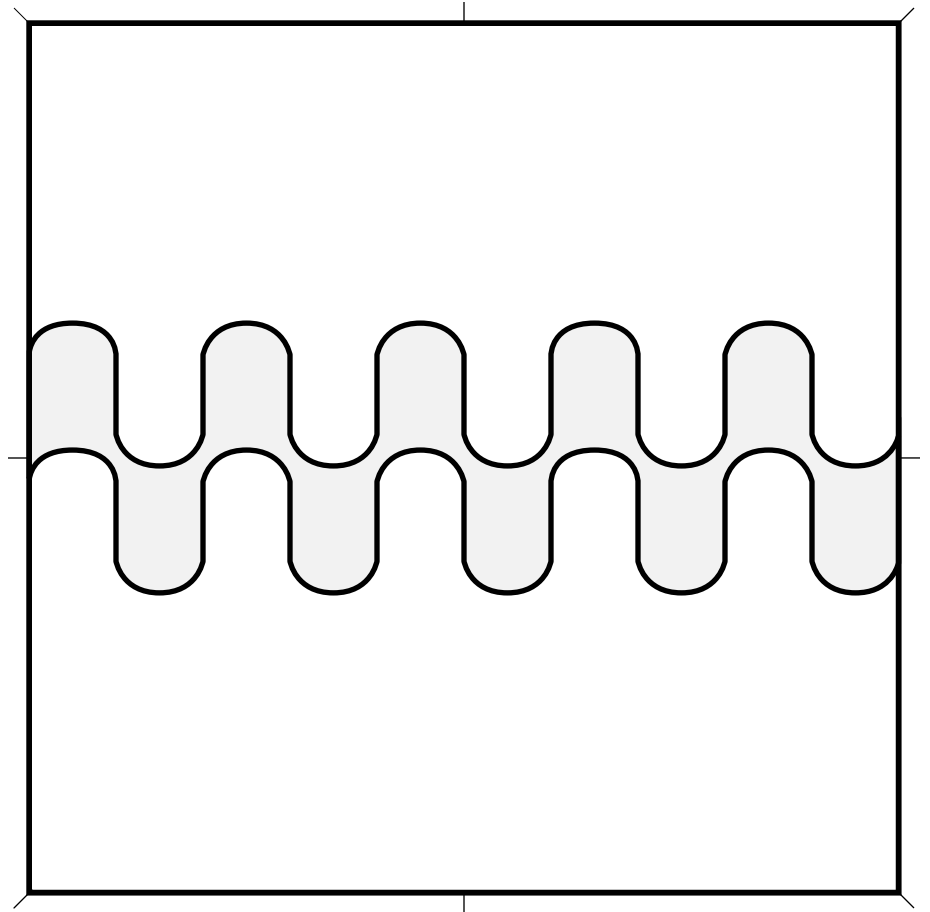
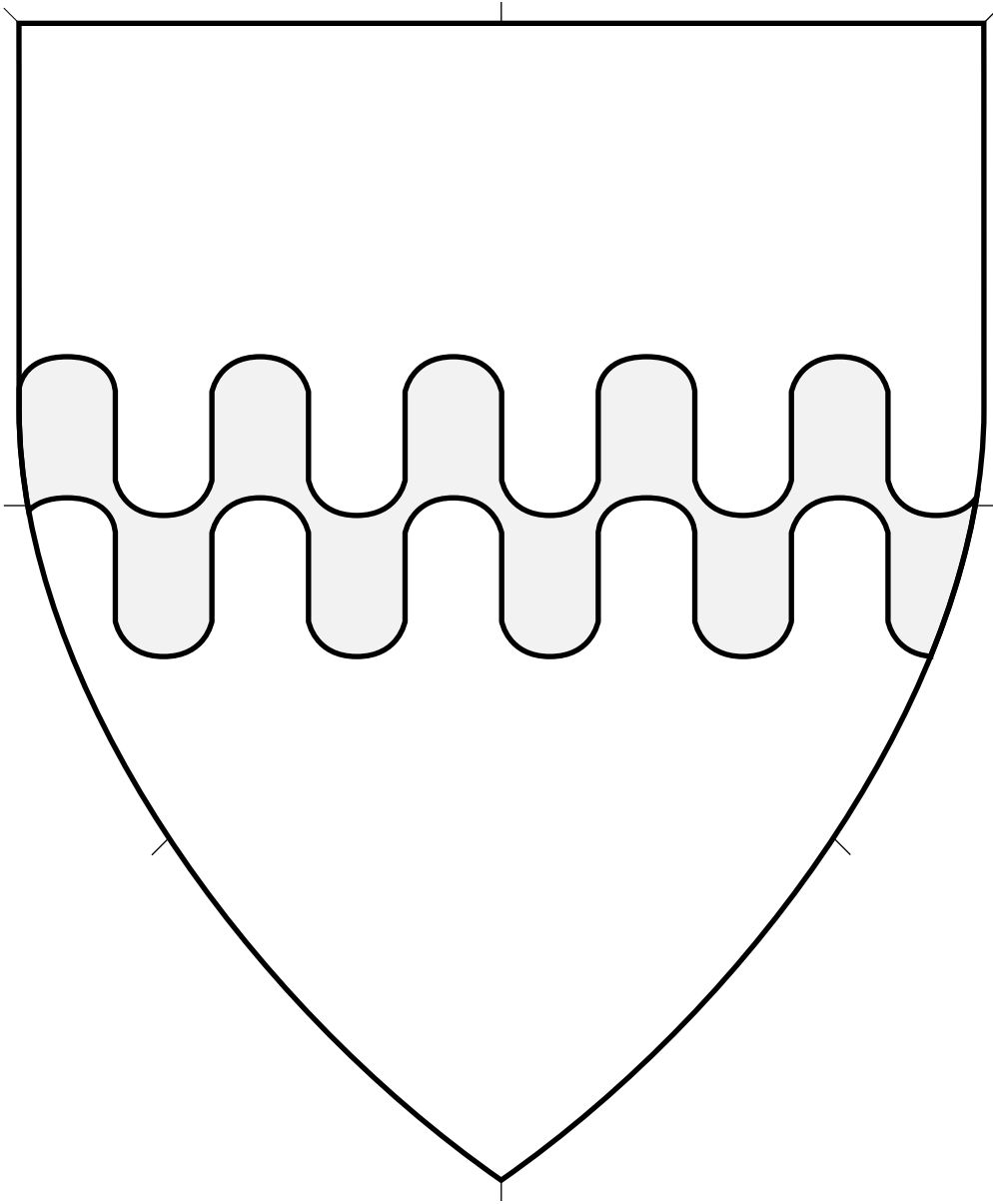

Central ordinary.

Fess Wavy (4) 4.444

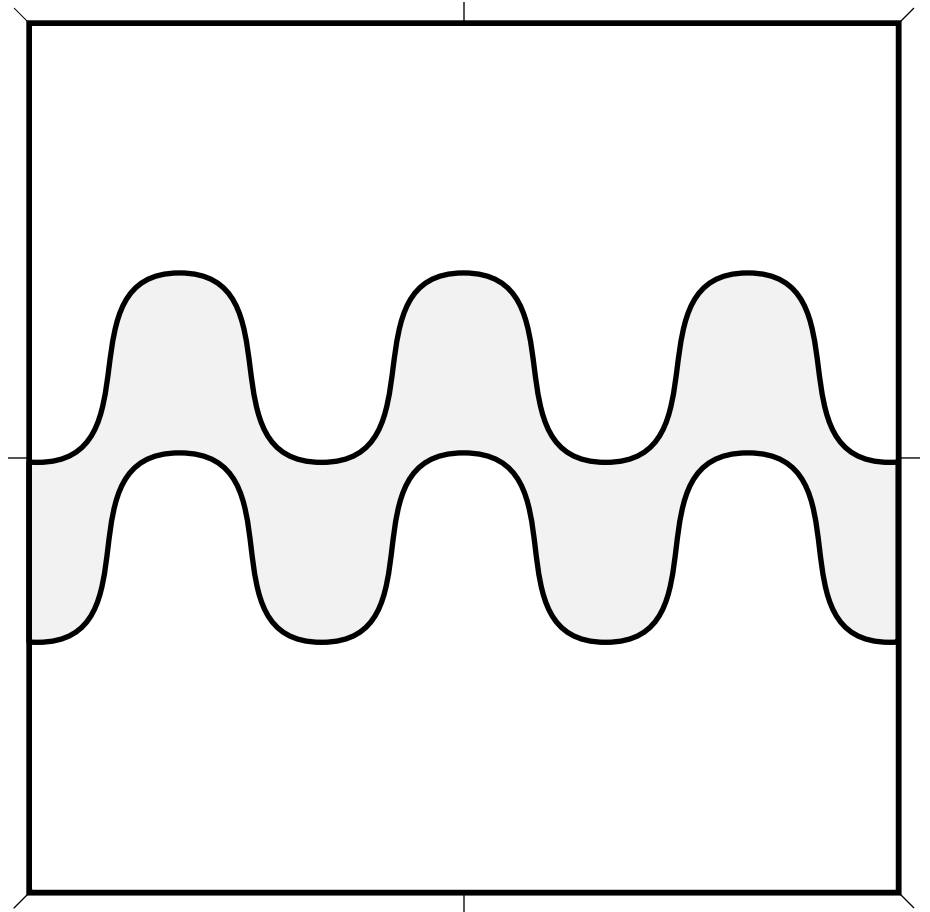
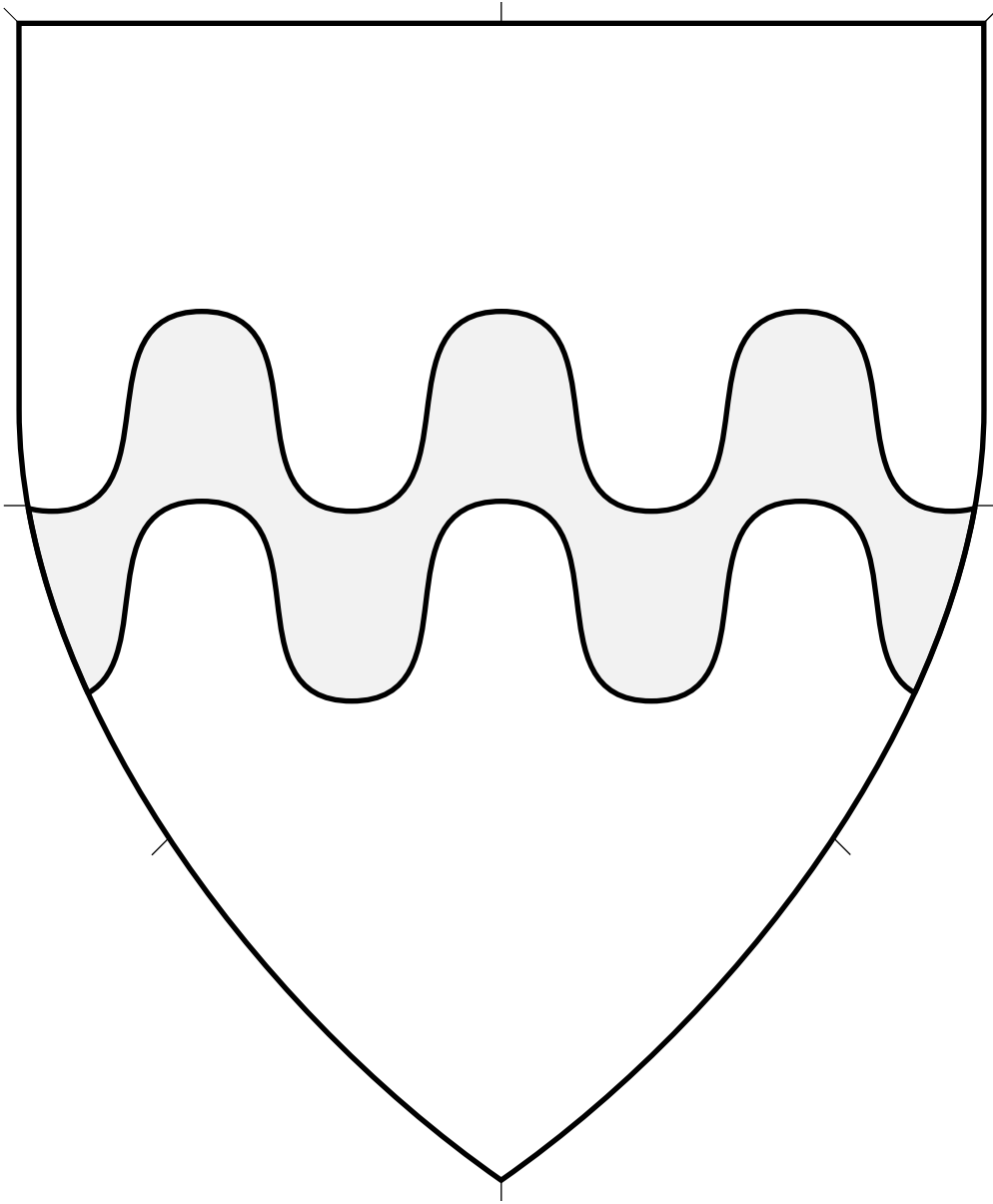

Central ordinary.

Fess Wavy (5) 4.445

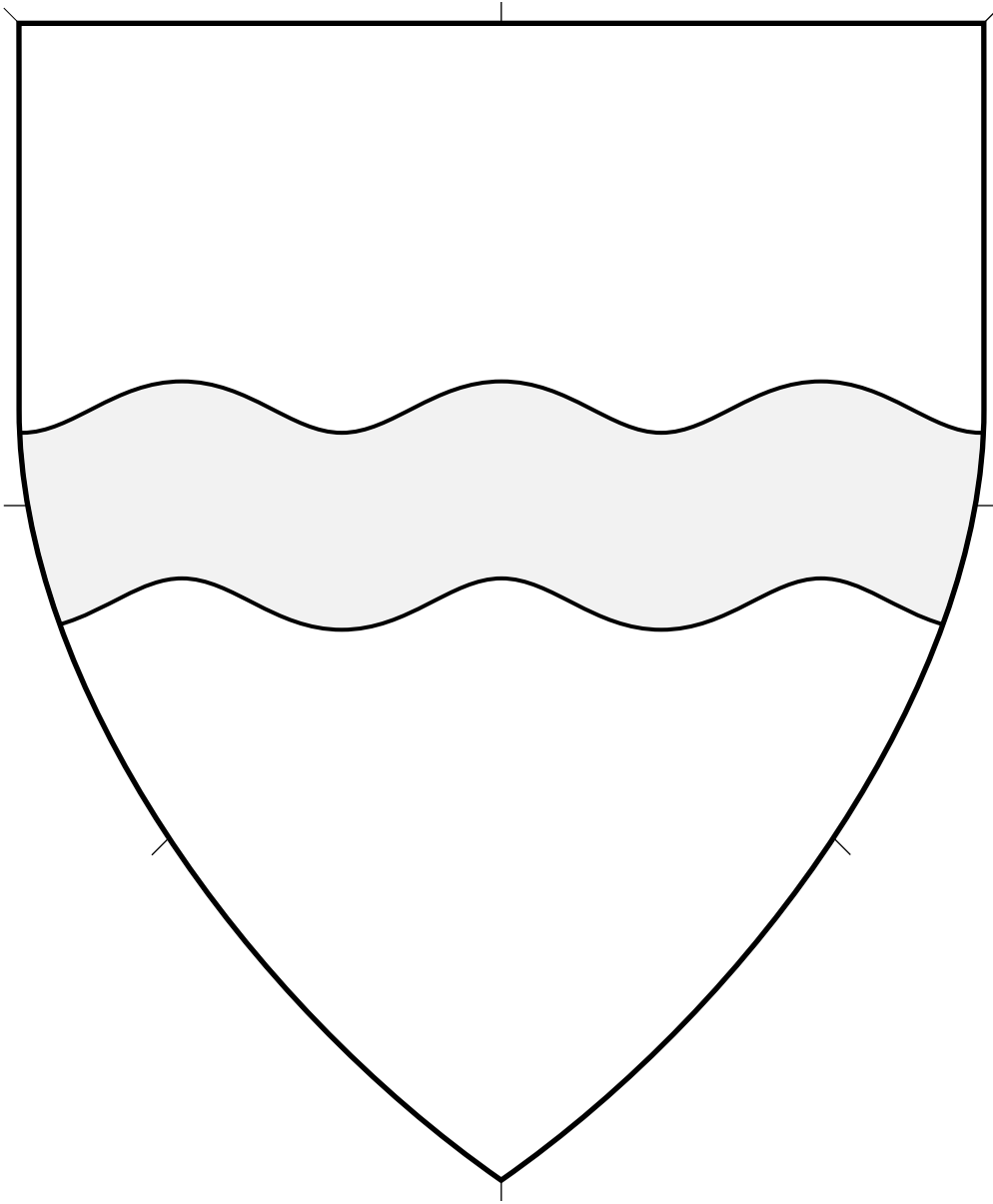

Central ordinary.

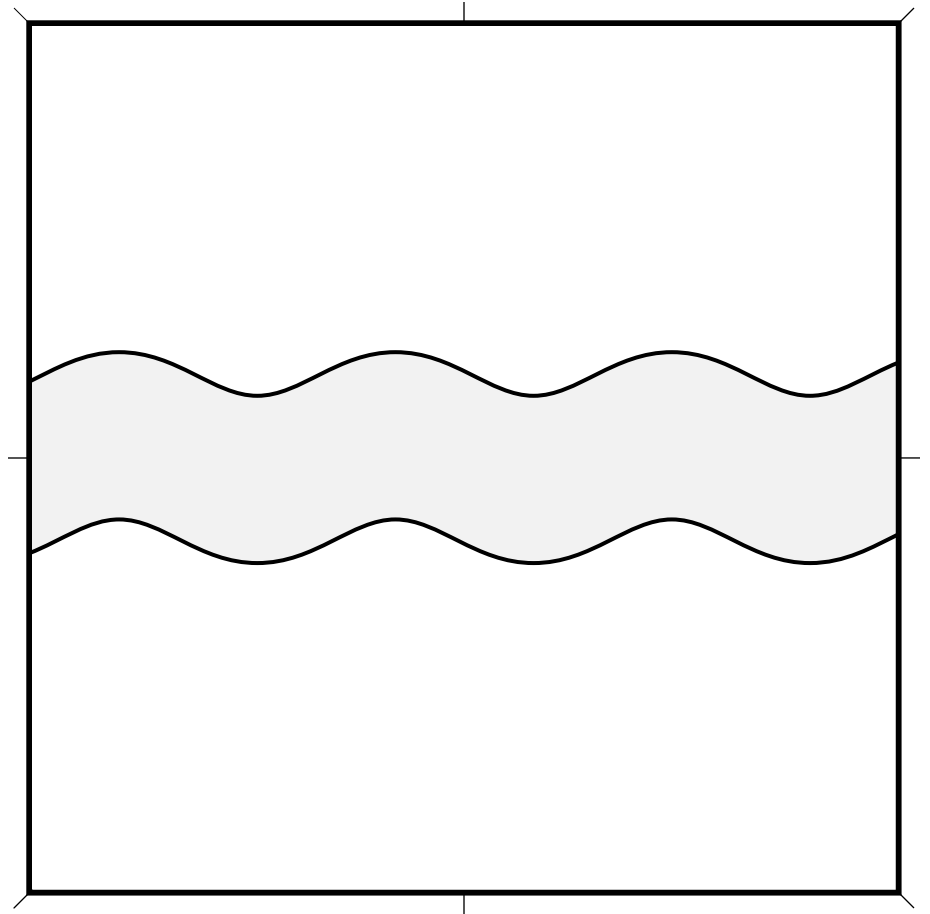

Fess Wavy (6) 4.446

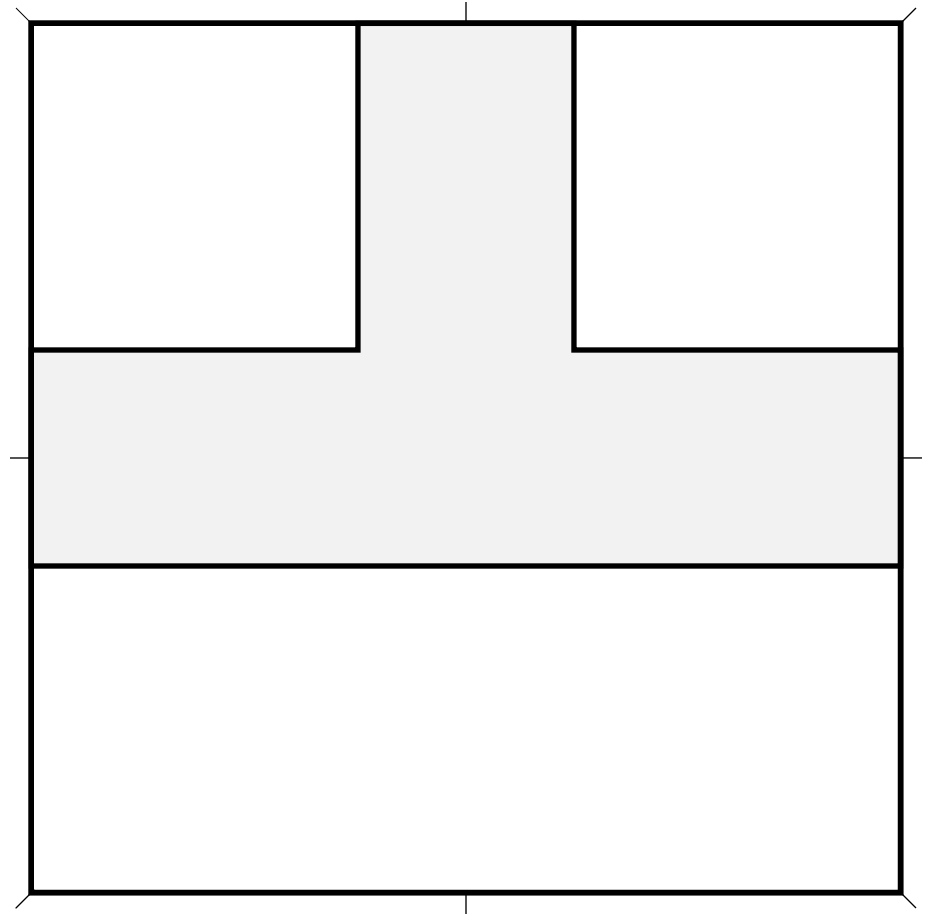
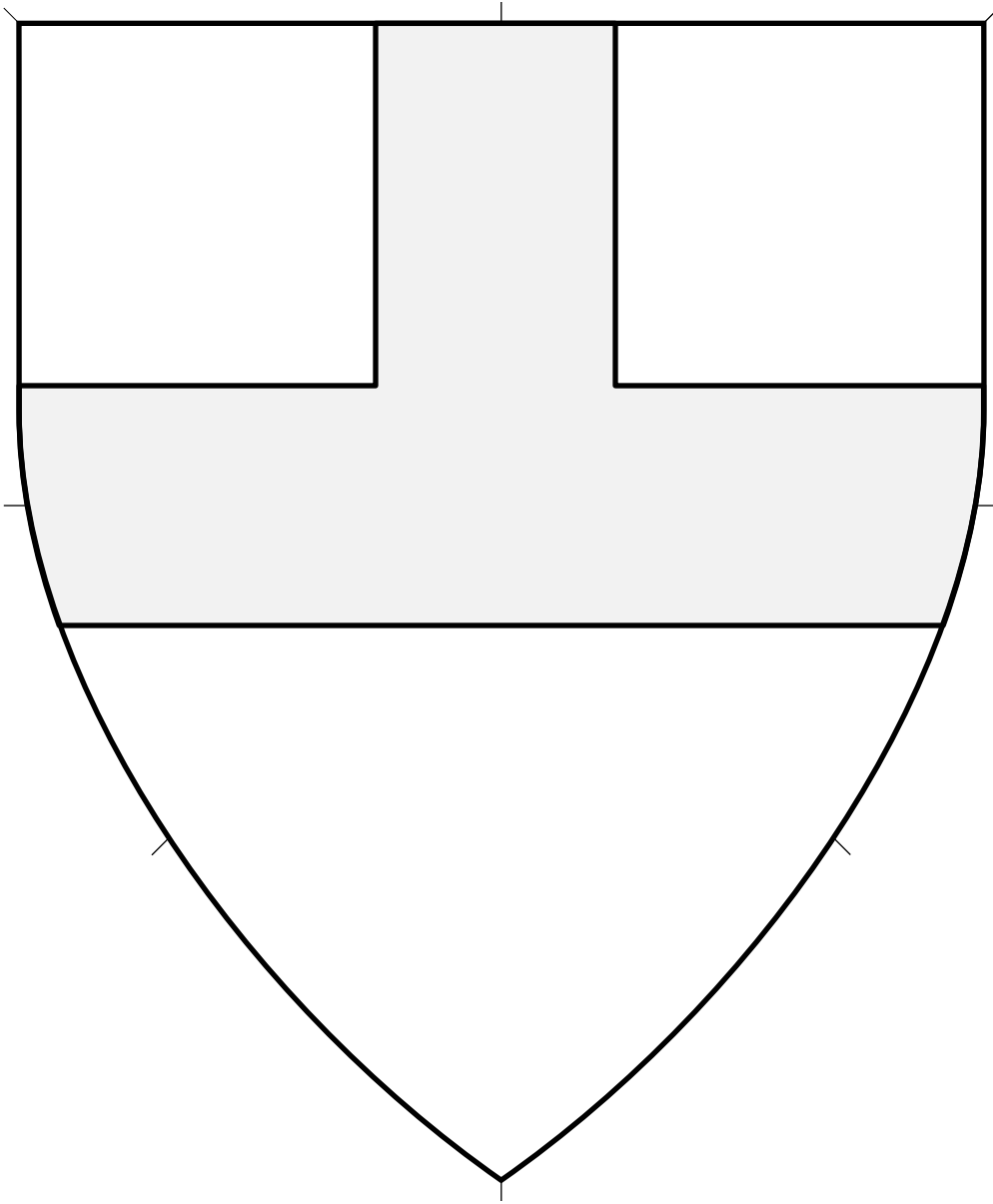

Central ordinary.

Fess Conjoined In Chief With a Demi-Pale 4.447

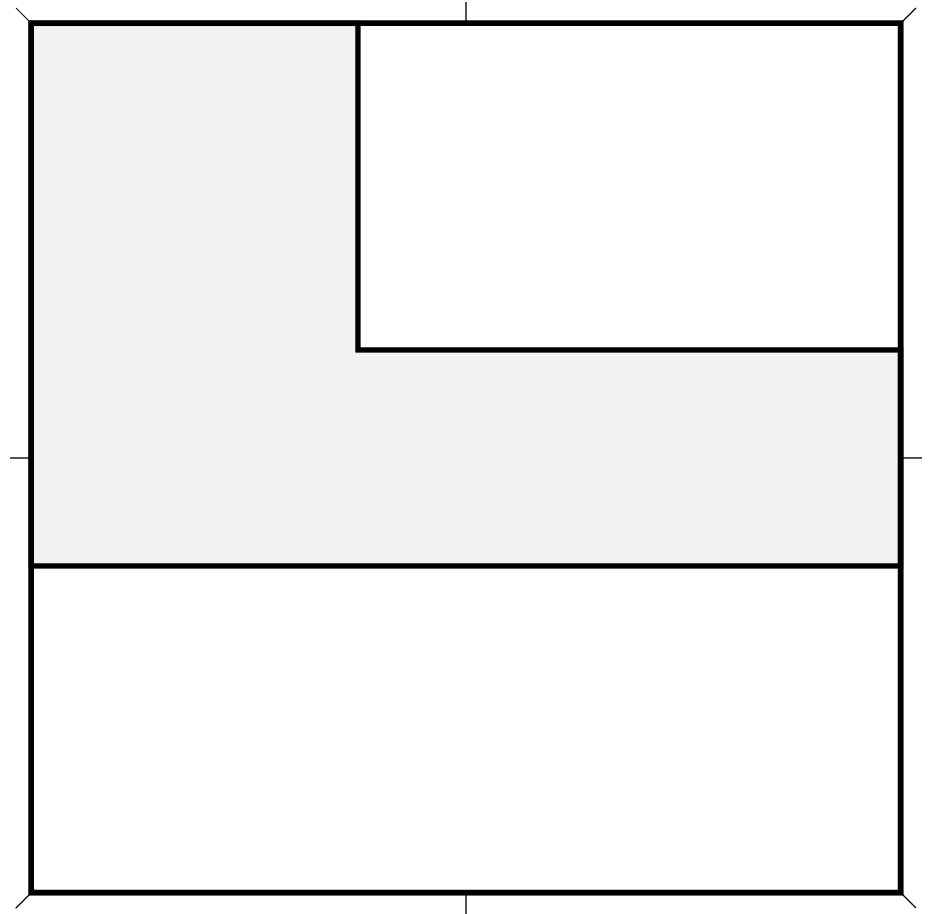
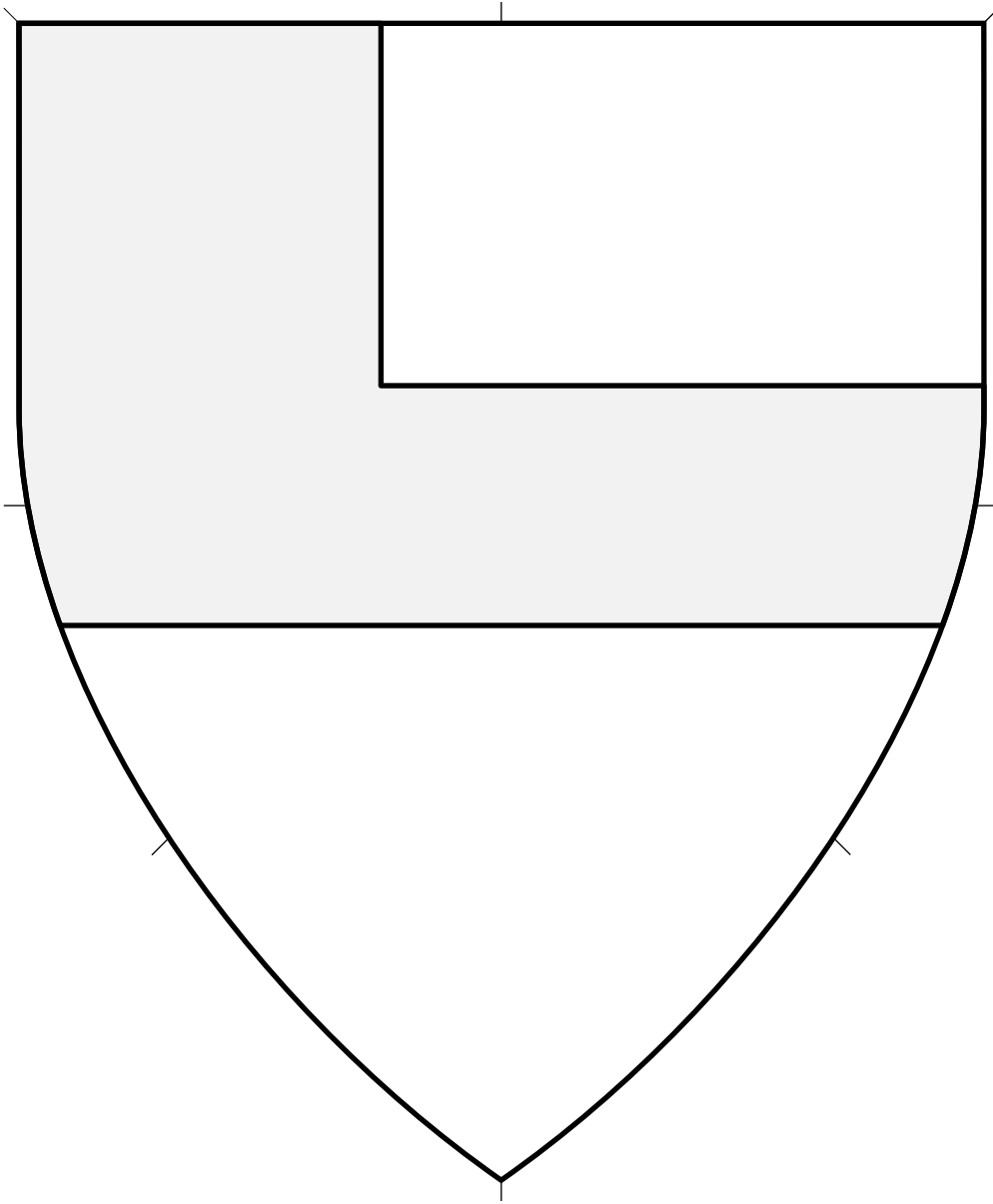

Central ordinary.

Fess Conjoined With a Canton 4.448

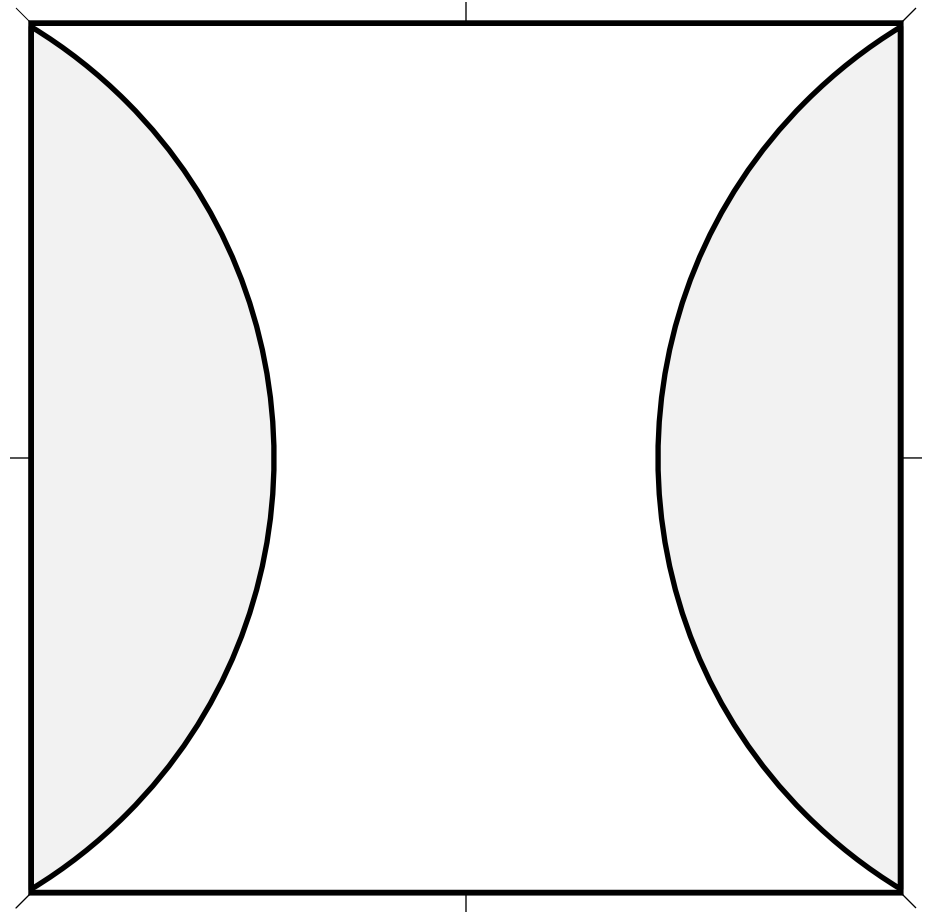
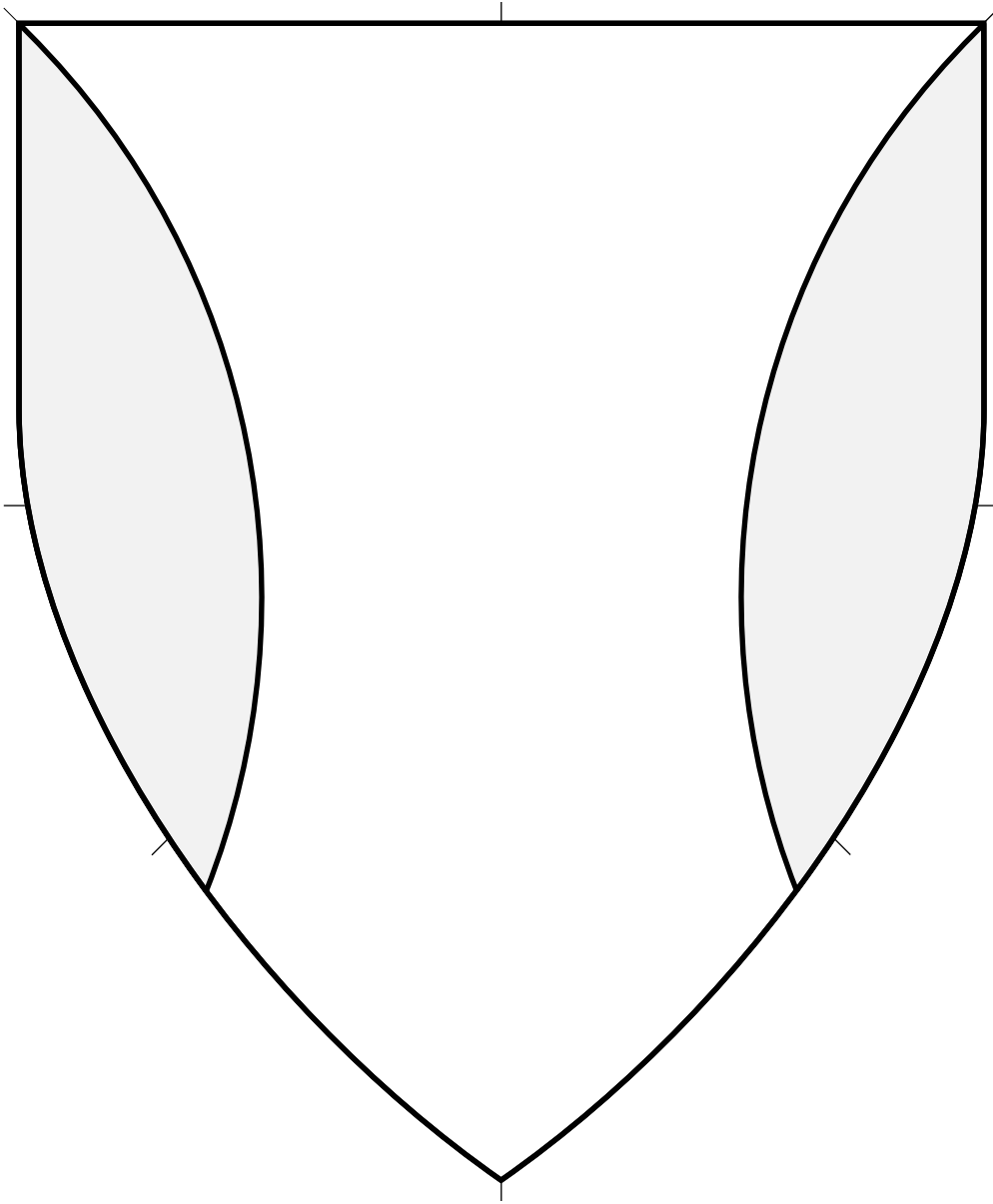

Peripheral ordinary. Always appear together as a pair. May be charged.

Flaunches (1) 4.449

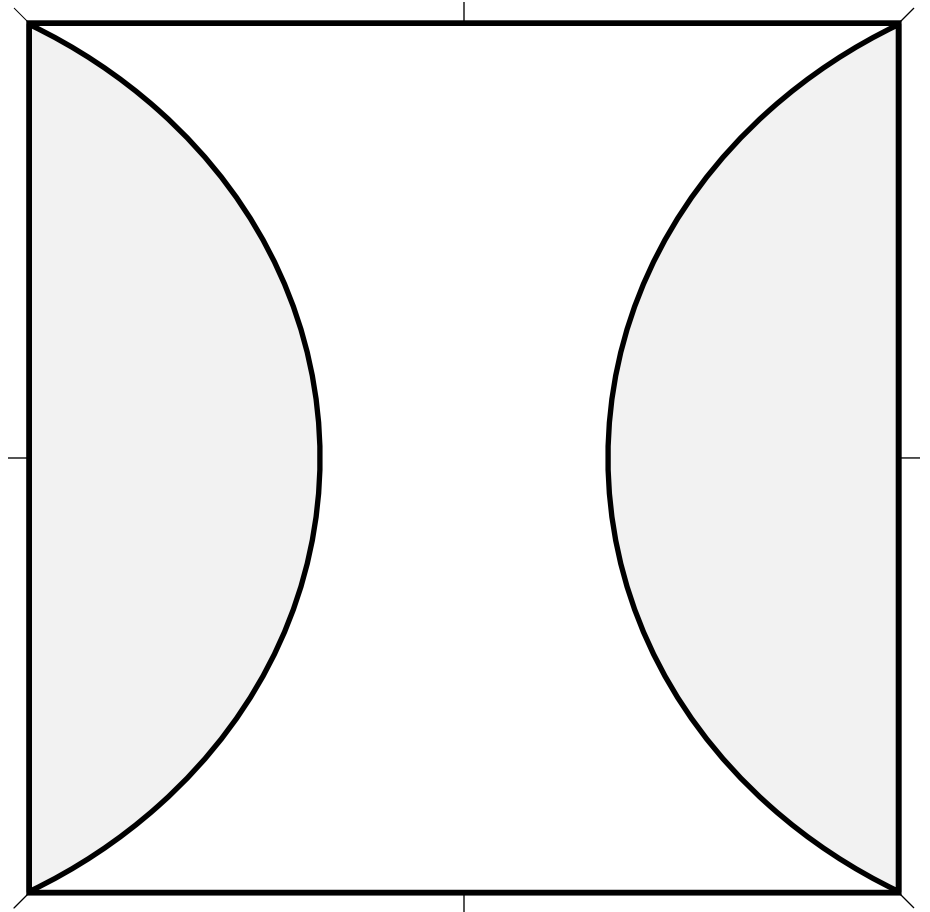
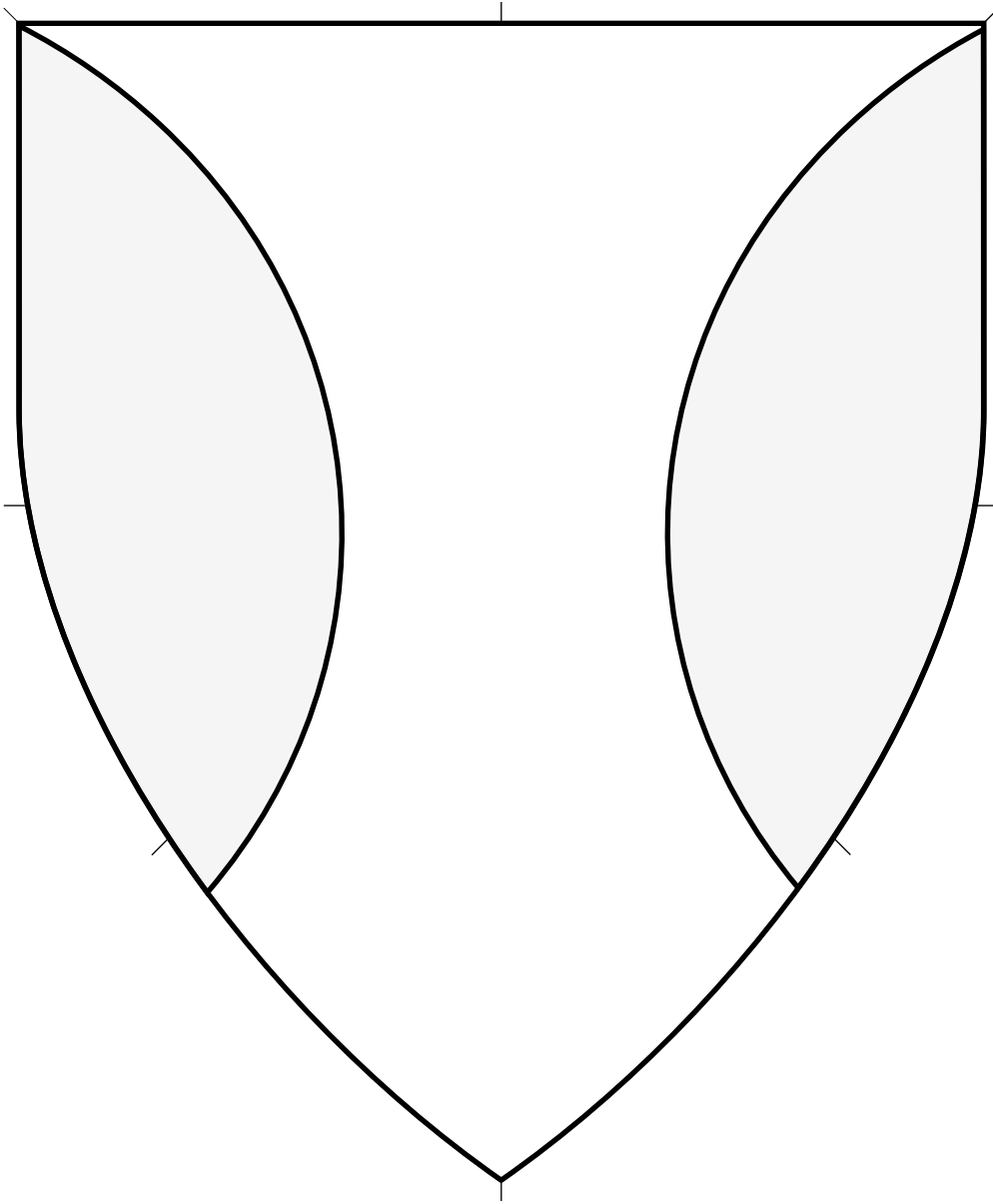

Peripheral ordinary. Always appear together as a pair. May be charged.

Flanches (2) 4.450

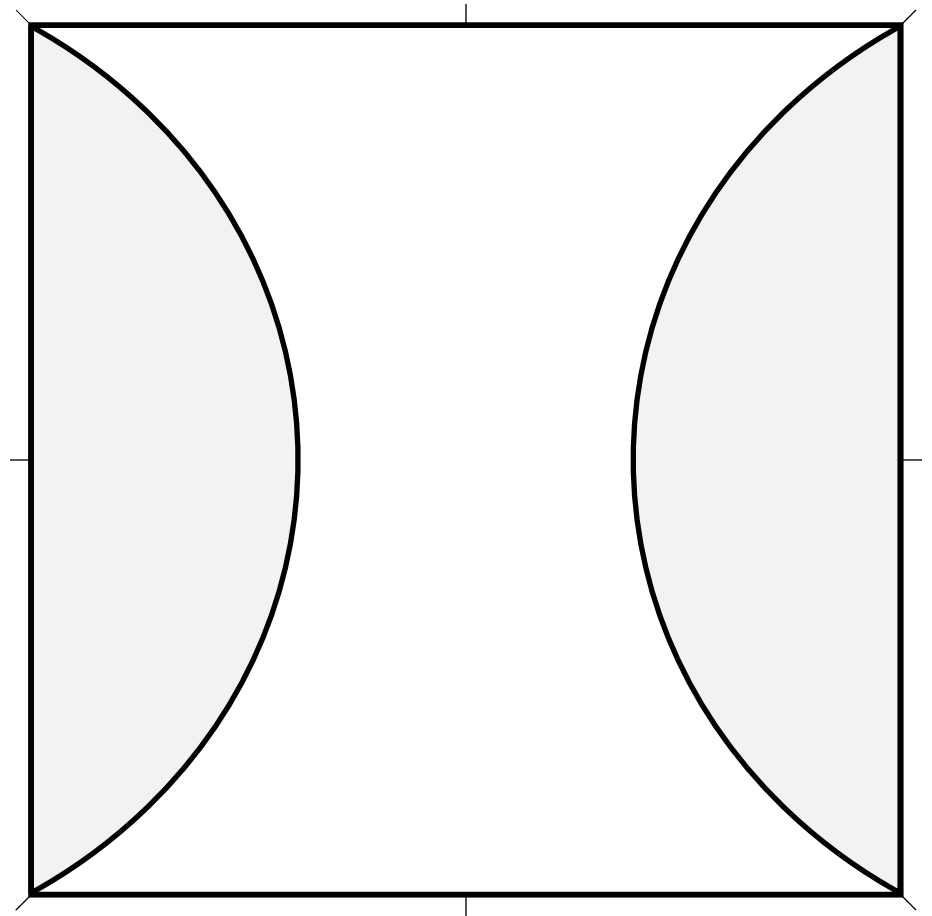
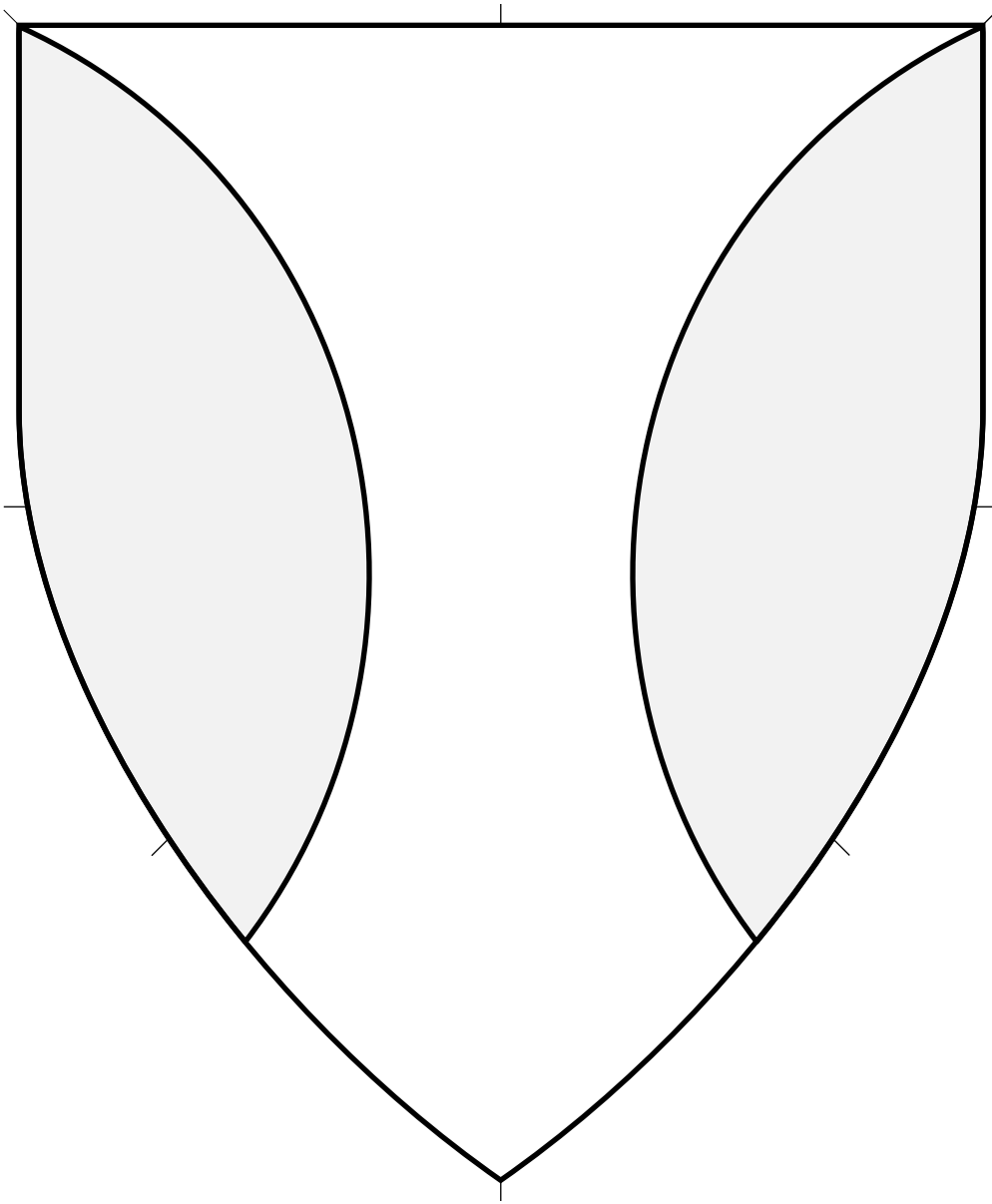

Peripheral ordinary.

Source: Viking Answer Lady SVG Images For Heraldry.
Artist: Gunnvôr silfrahárr. Adapted by Mathghamhain Ua Ruadháin.

Flaunches (3) 4.451

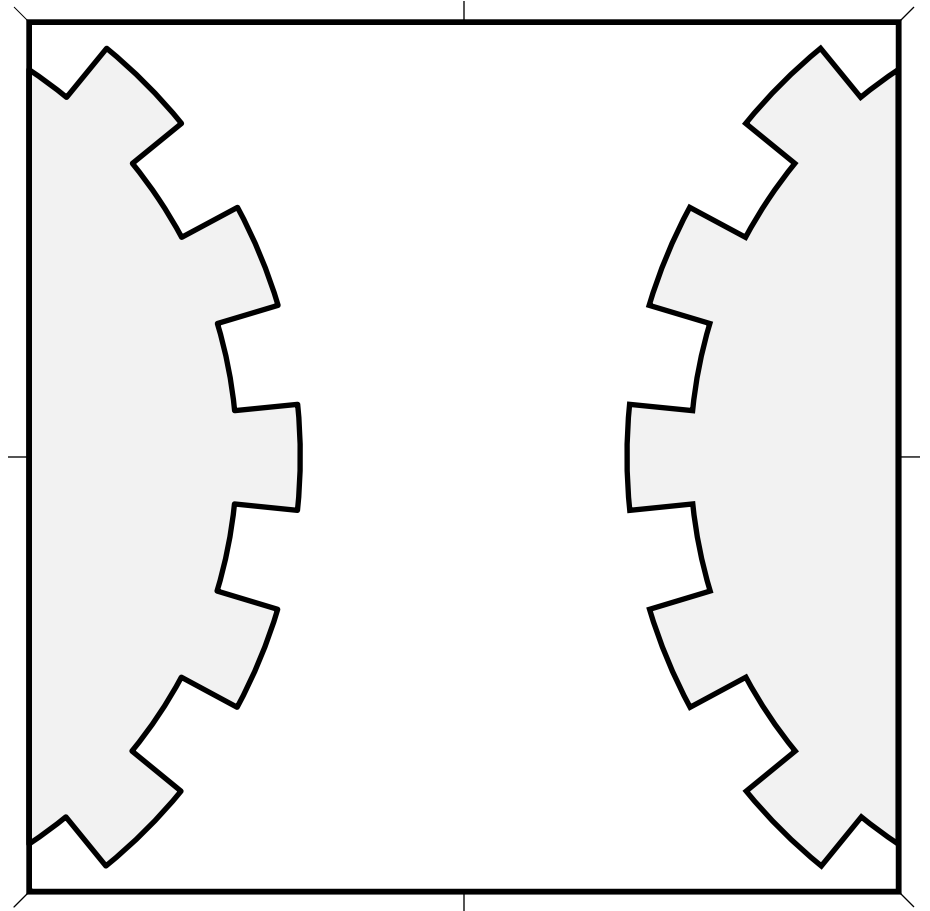
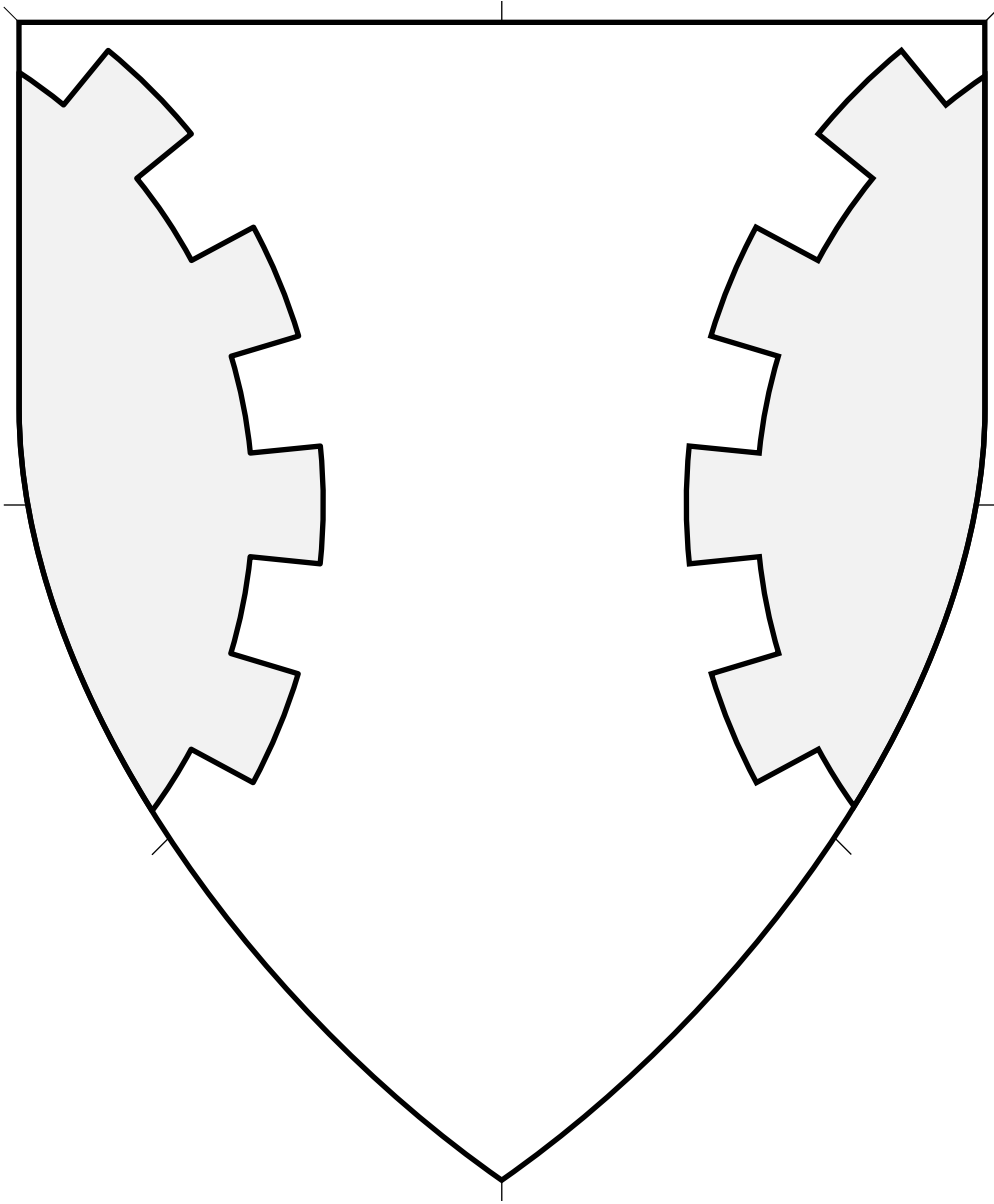

Peripheral ordinary. Always appear together as a pair. May be charged.

Flanches Embattled 4.452

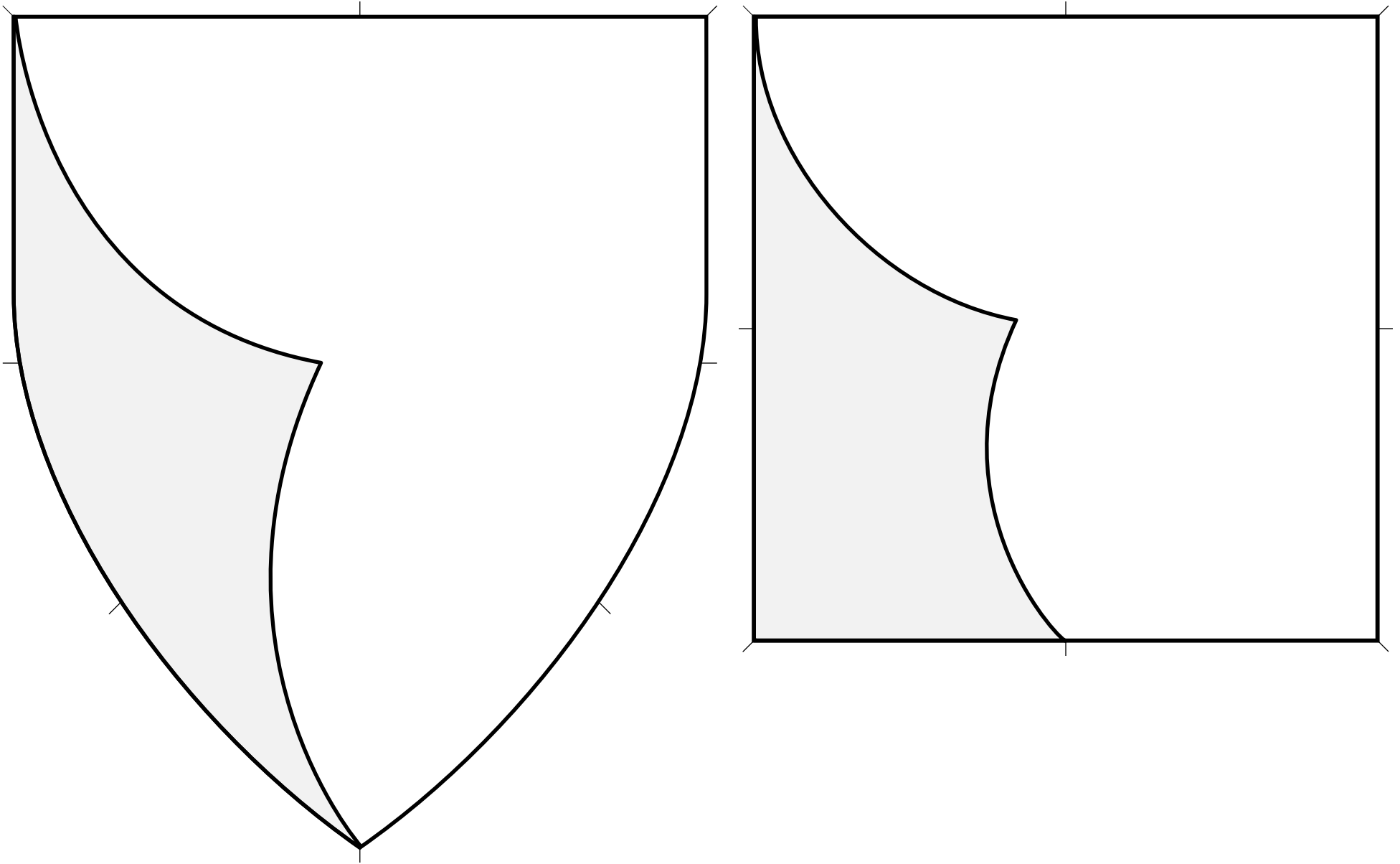

Peripheral ordinary.

Use of both a gore and a gore sinister, or use of a charged gore, would be considered a step from core practice (SFCP).

Gore (1) 4.453

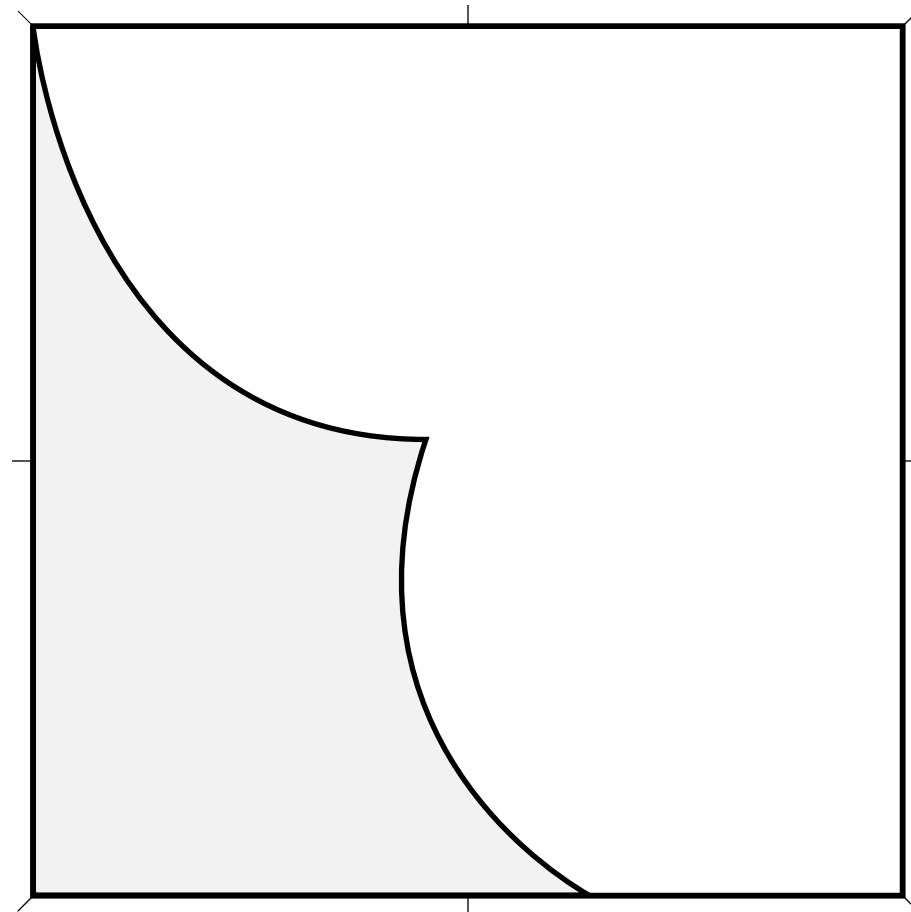
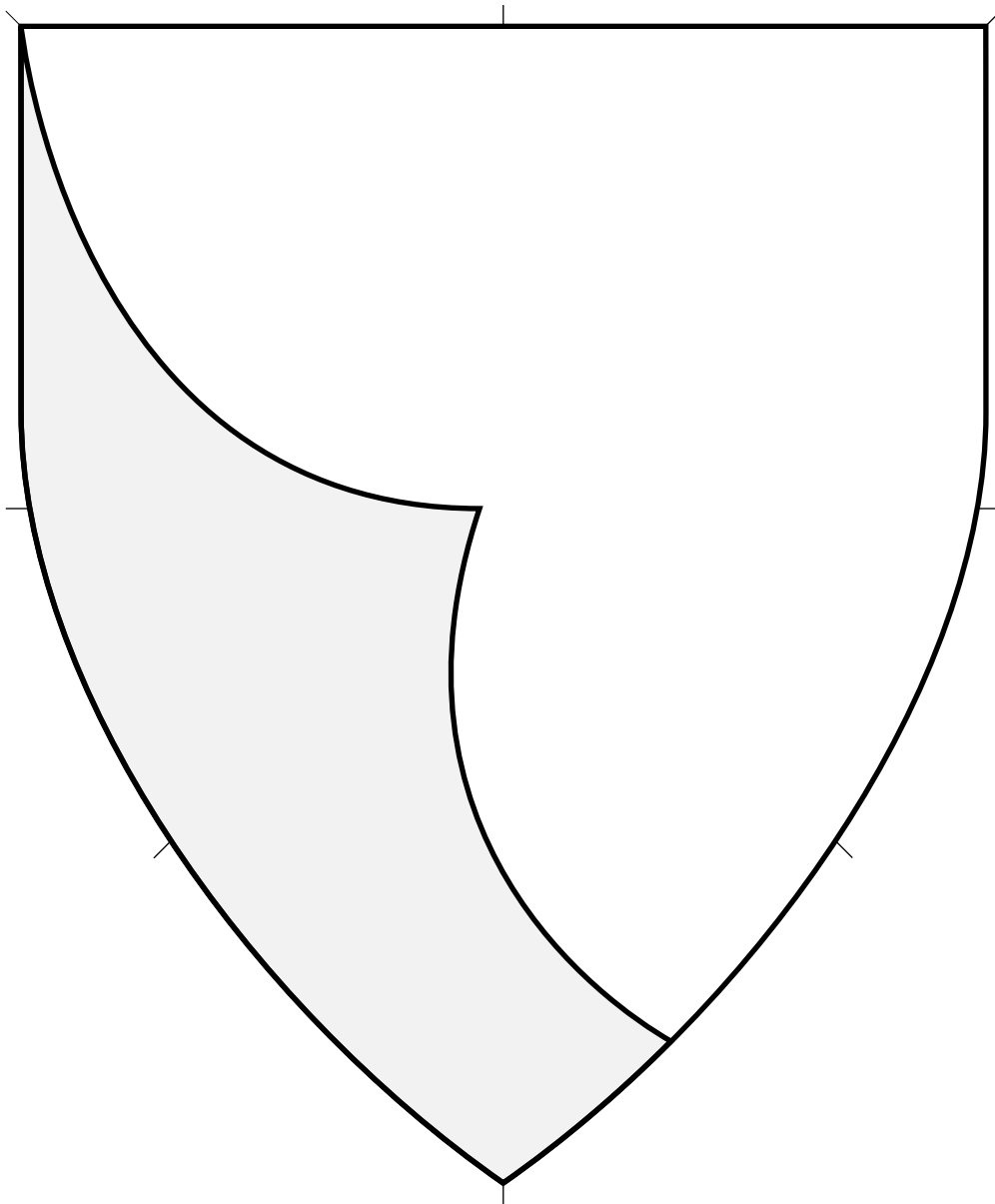

Peripheral ordinary.

Use of both a gore and a gore sinister, or use of a charged gore, would be considered a step from core practice (SFCP).

Source: Wappen besonders von deutschen Geschlechtern.

Artist unknown. (Folio 40v.)

Gore (2) 4.454

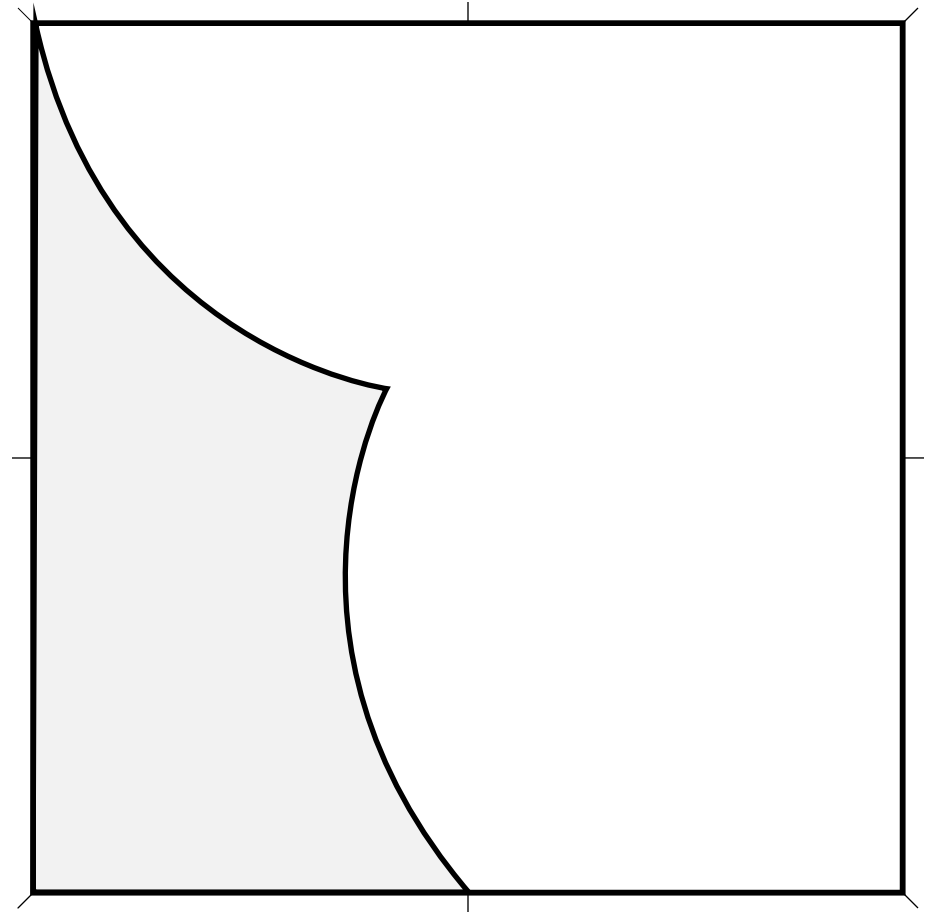
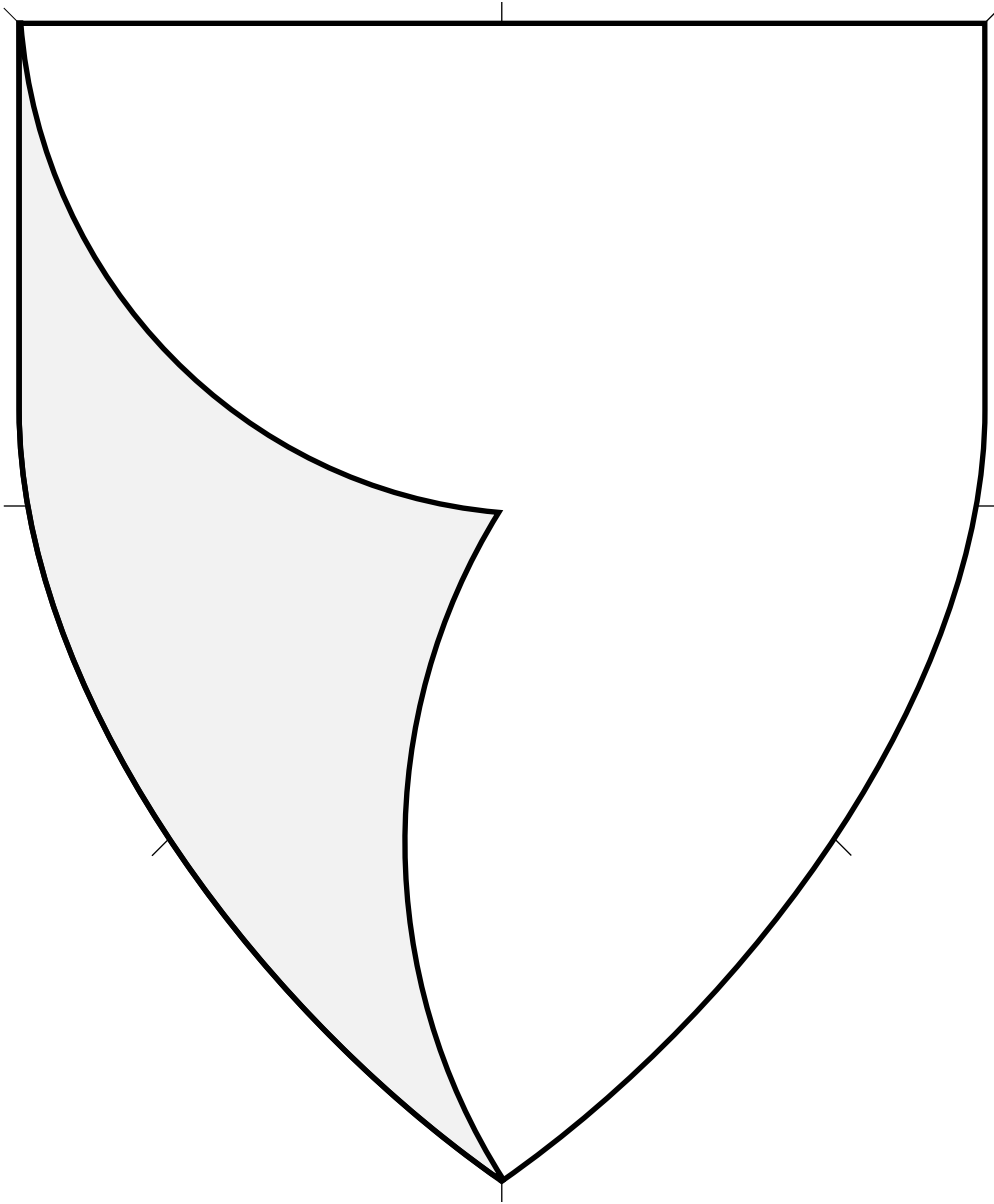

Peripheral ordinary.

Use of both a gore and a gore sinister, or use of a charged gore, would be considered a step from core practice (SFCP).

Source: Viking Answer Lady SVG Images For Heraldry.

Artist: Gunnvôr silfrhárr. Adapted by Mathghamhain Ua Ruadháin.

Gore (3) 🐉 4.455

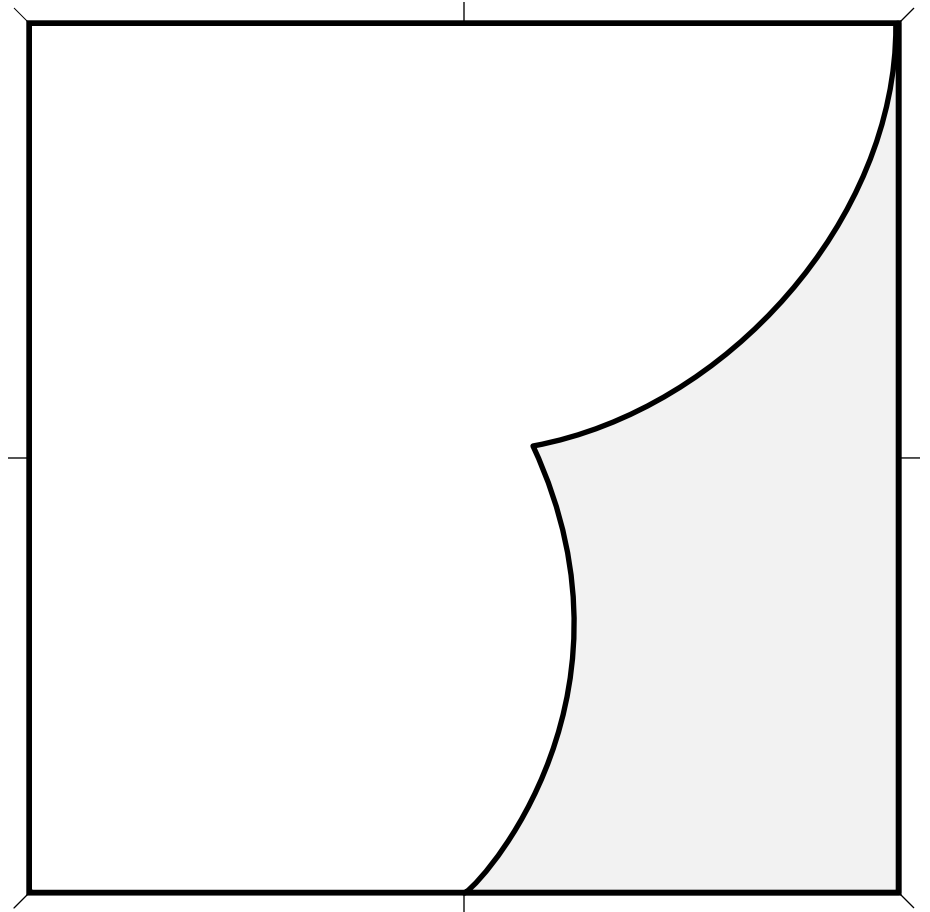
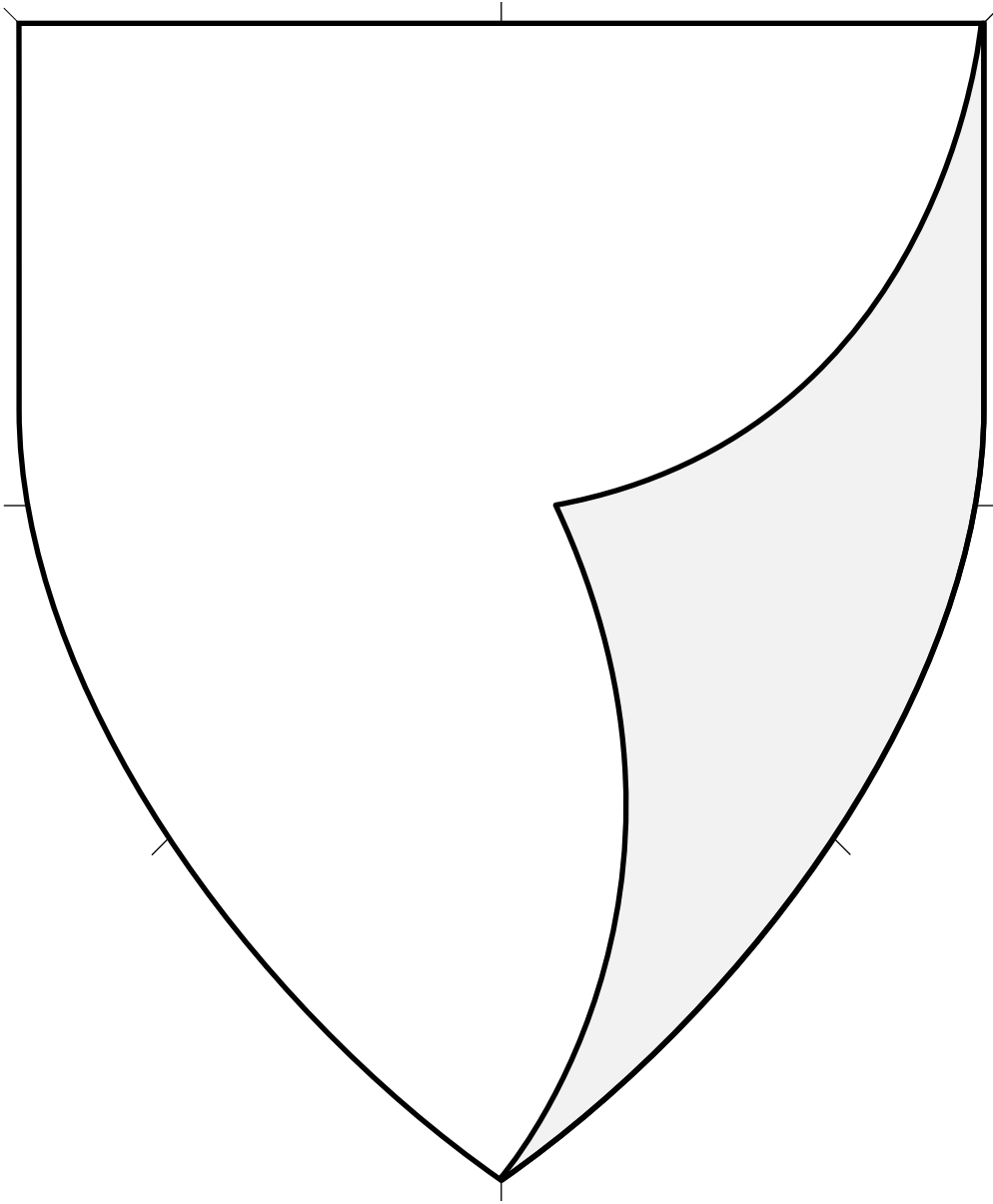

Peripheral ordinary.

Use of both a gore and a gore sinister, or use of a charged gore, would be considered a step from core practice (SFCP).

Gore Sinister 4.456

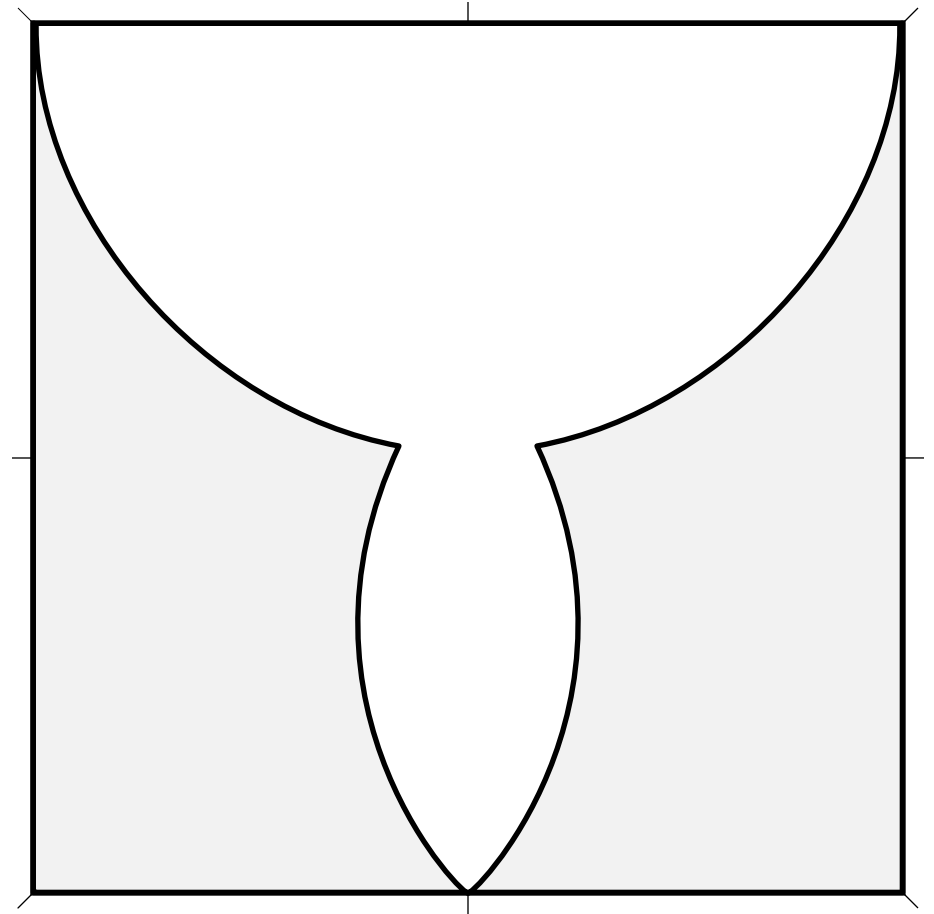
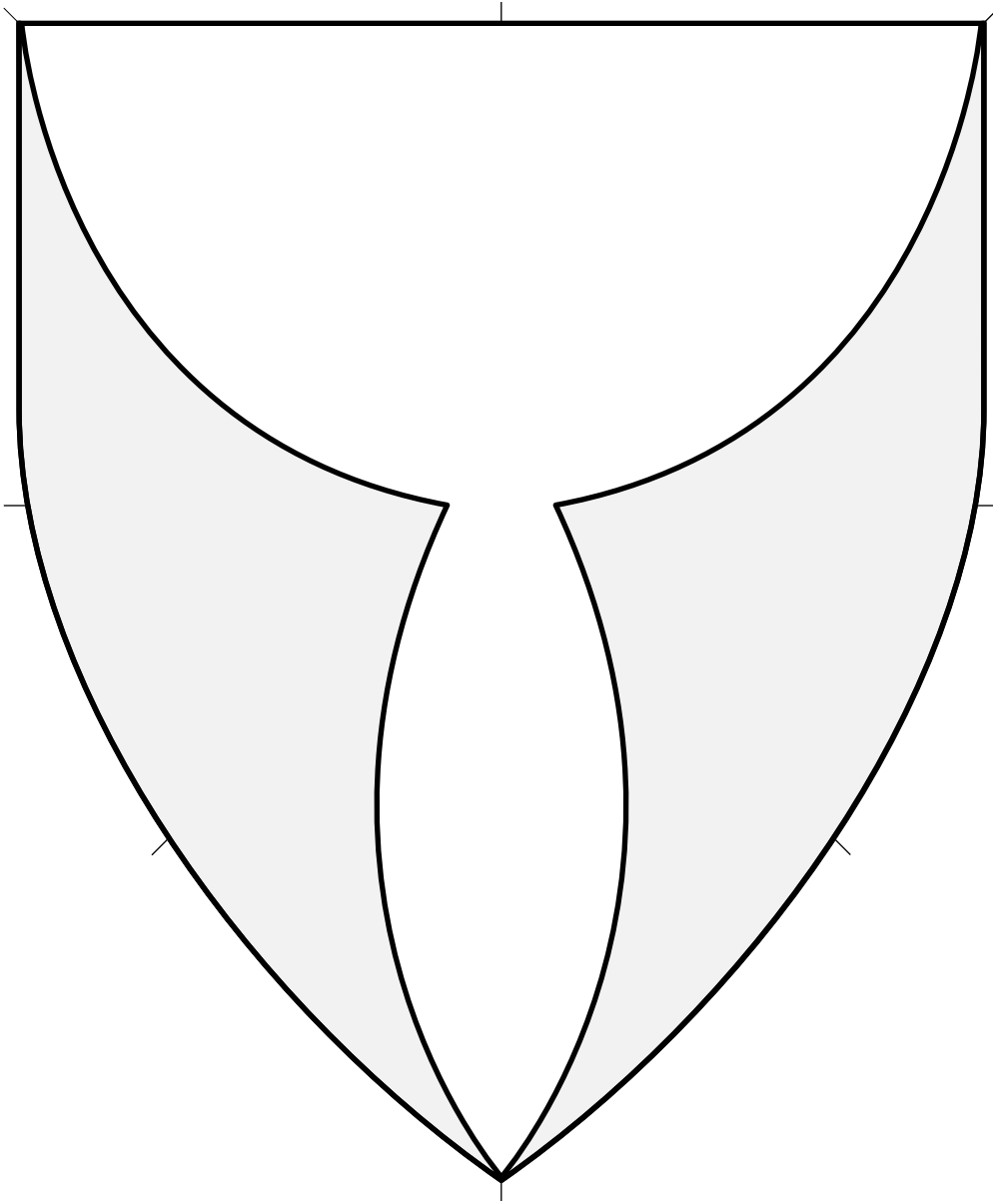

Peripheral ordinary.

Use of both a gore and a gore sinister, or use of a charged gore, would be considered a step from core practice (SFCP).

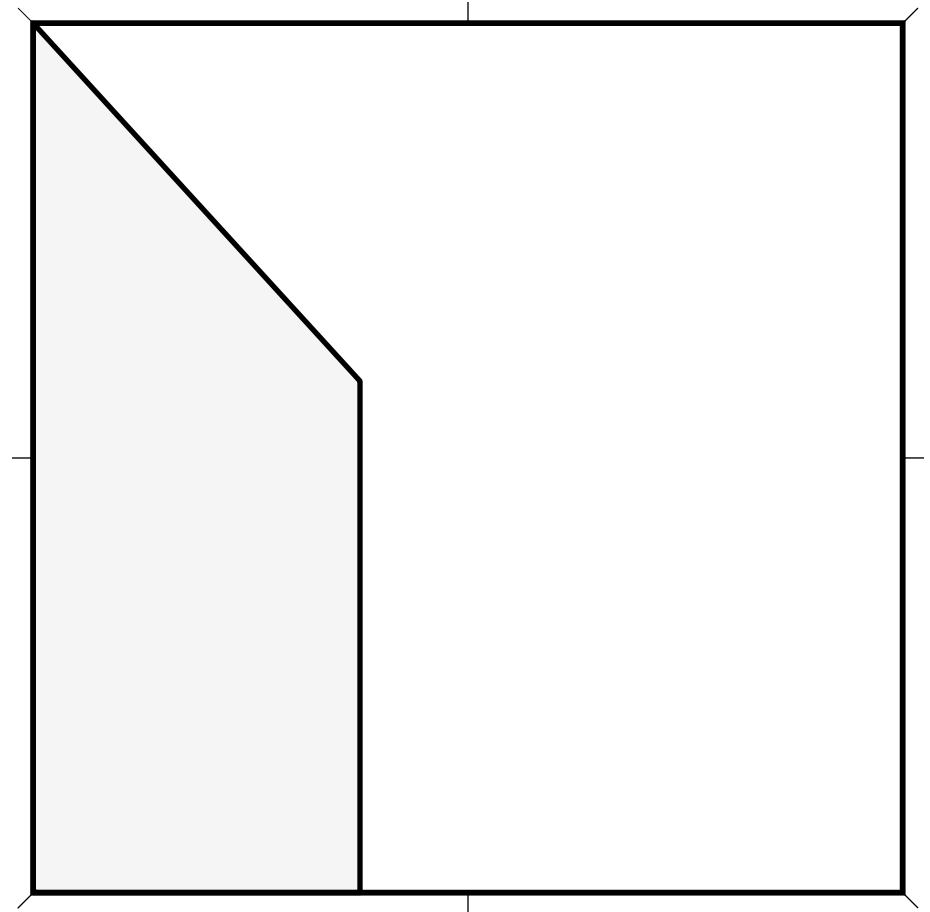
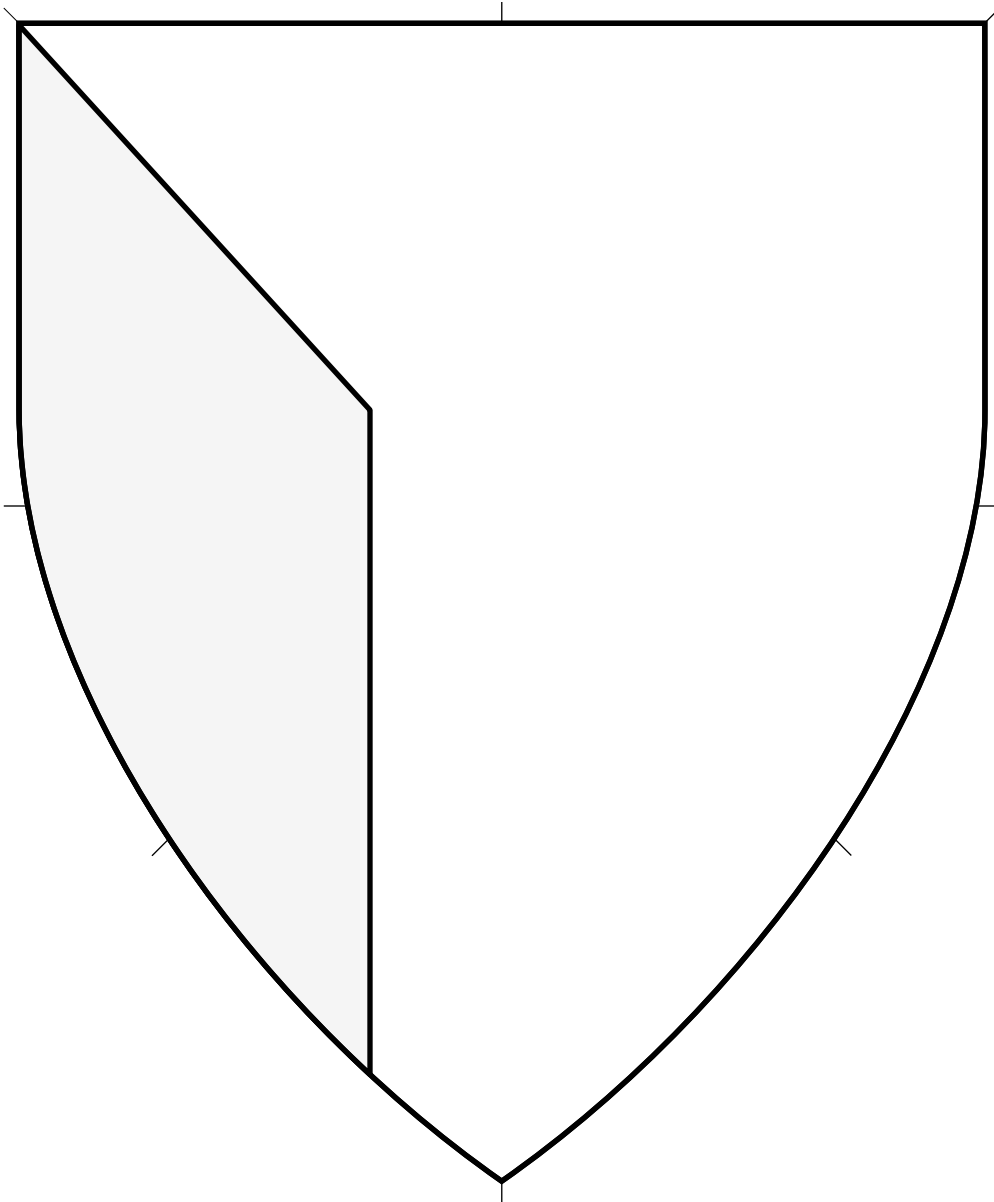

Peripheral ordinary. A straight-line variant of the gore.

Appears on dexter side unless blazoned a “gusset sinister;” frequently both are included, and blazoned “two gussets.”

Use of a charged gusset would be considered a step from core practice (SFCP).

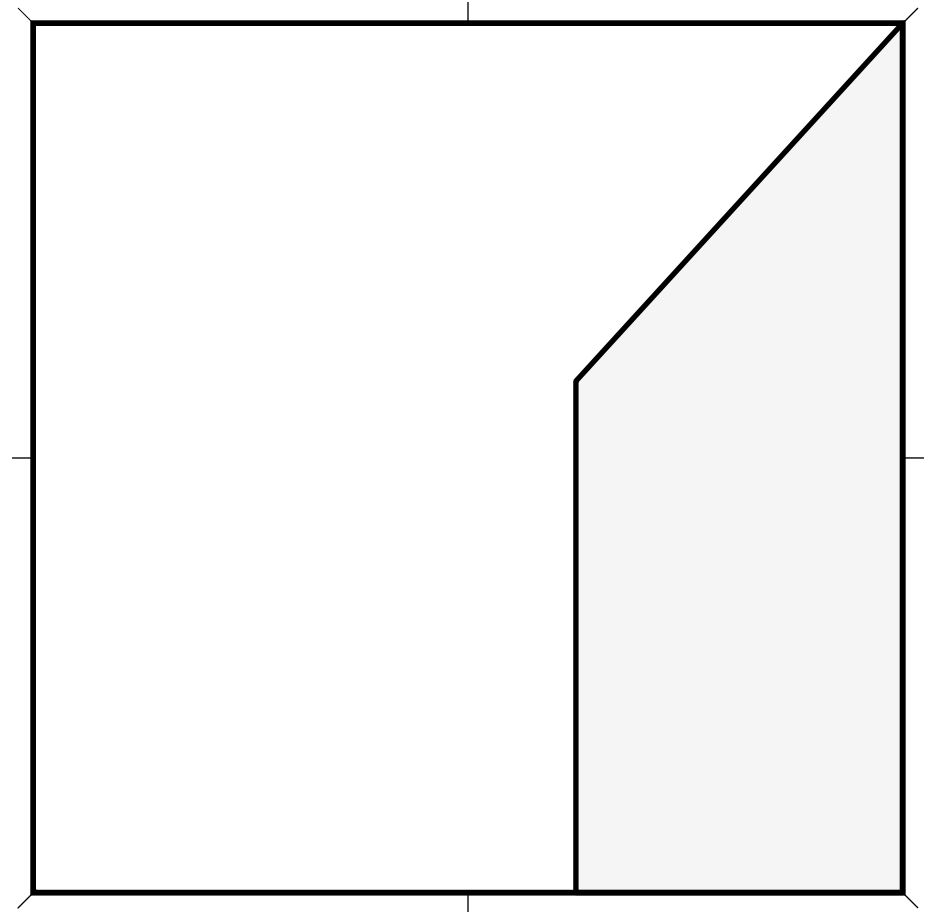
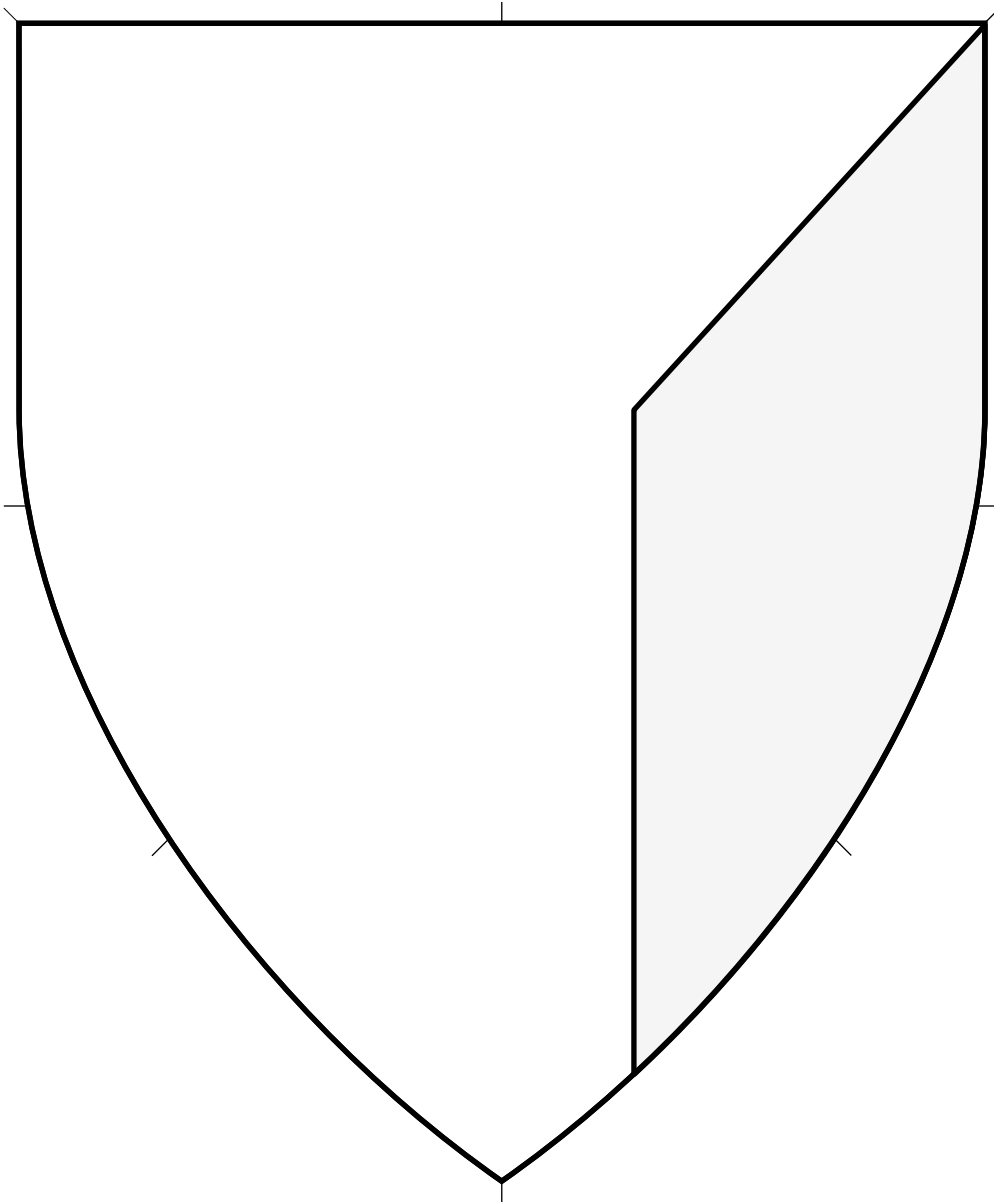

Peripheral ordinary. A straight-line variant of the gore.

Appears on dexter side unless blazoned a “gusset sinister;” frequently both are included, and blazoned “two gussets.”

Use of a charged gusset would be considered a step from core practice (SFCP).

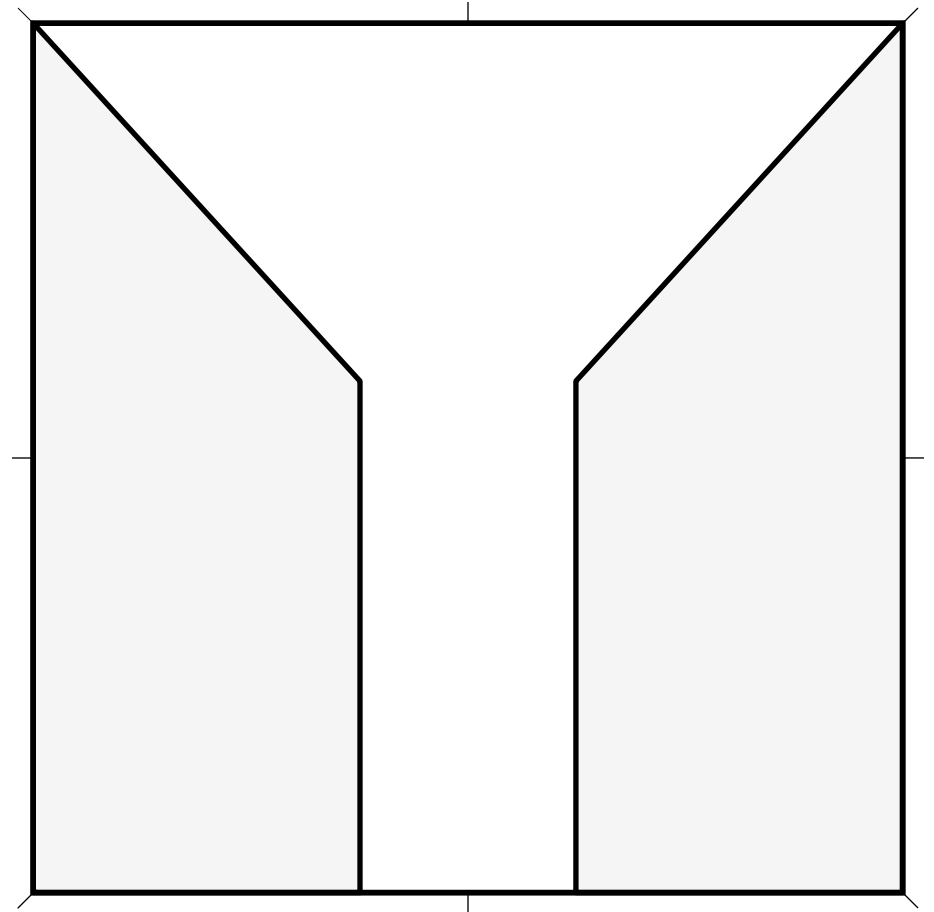
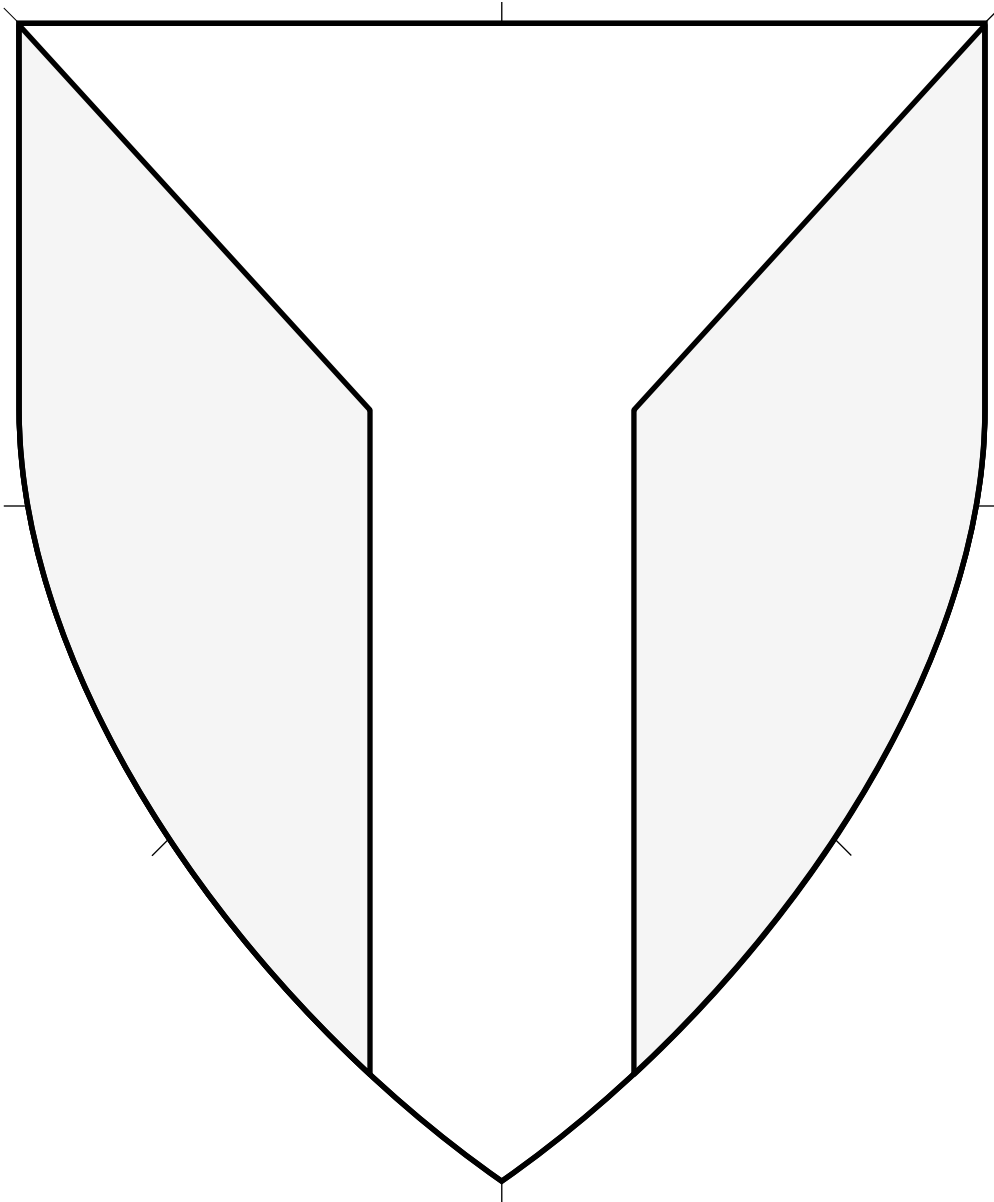

Peripheral ordinary. A straight-line variant of the gore.

Appears on dexter side unless blazoned a “gusset sinister;” frequently both are included, and blazoned “two gussets.”

Use of a charged gusset would be considered a step from core practice (SFCP).

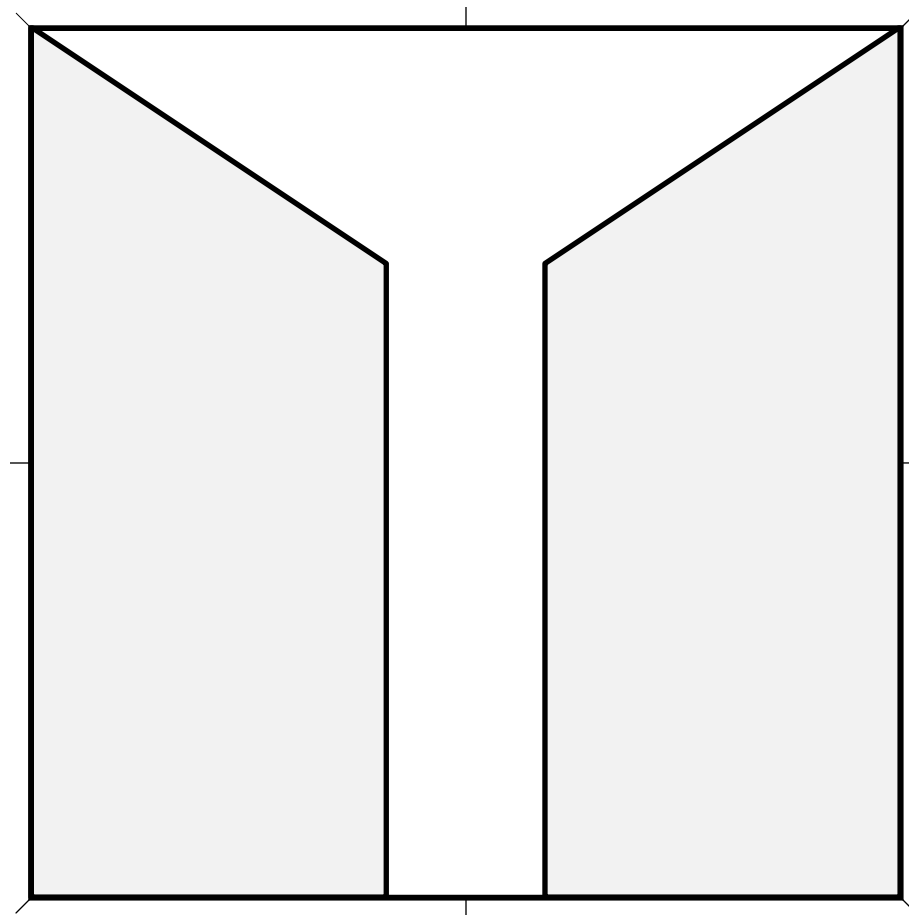
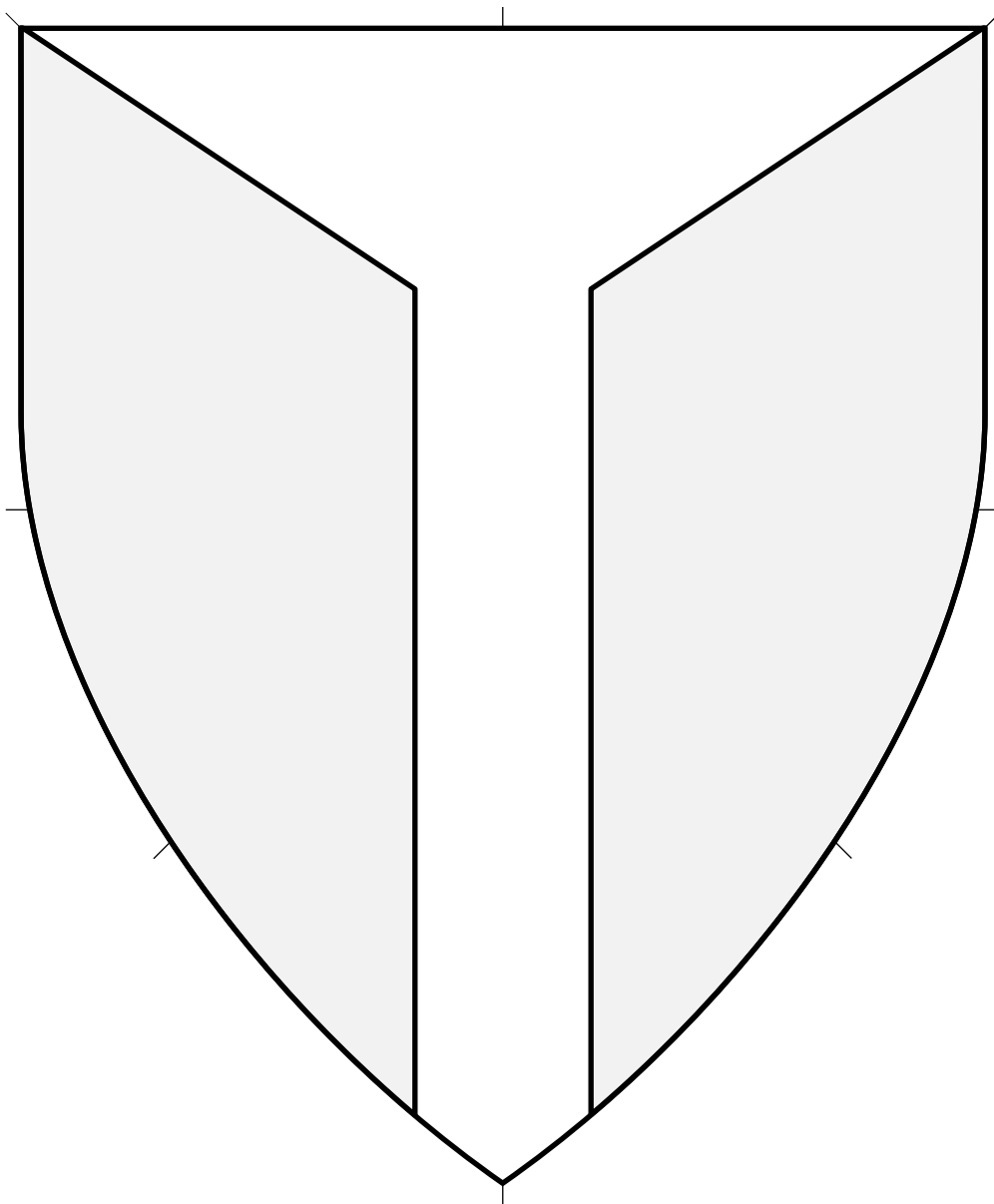

Peripheral ordinary.

Source: Viking Answer Lady SVG Images For Heraldry.
Artist: Gunnvôr silfrhárr.

Gussets, Two (2) 4.461

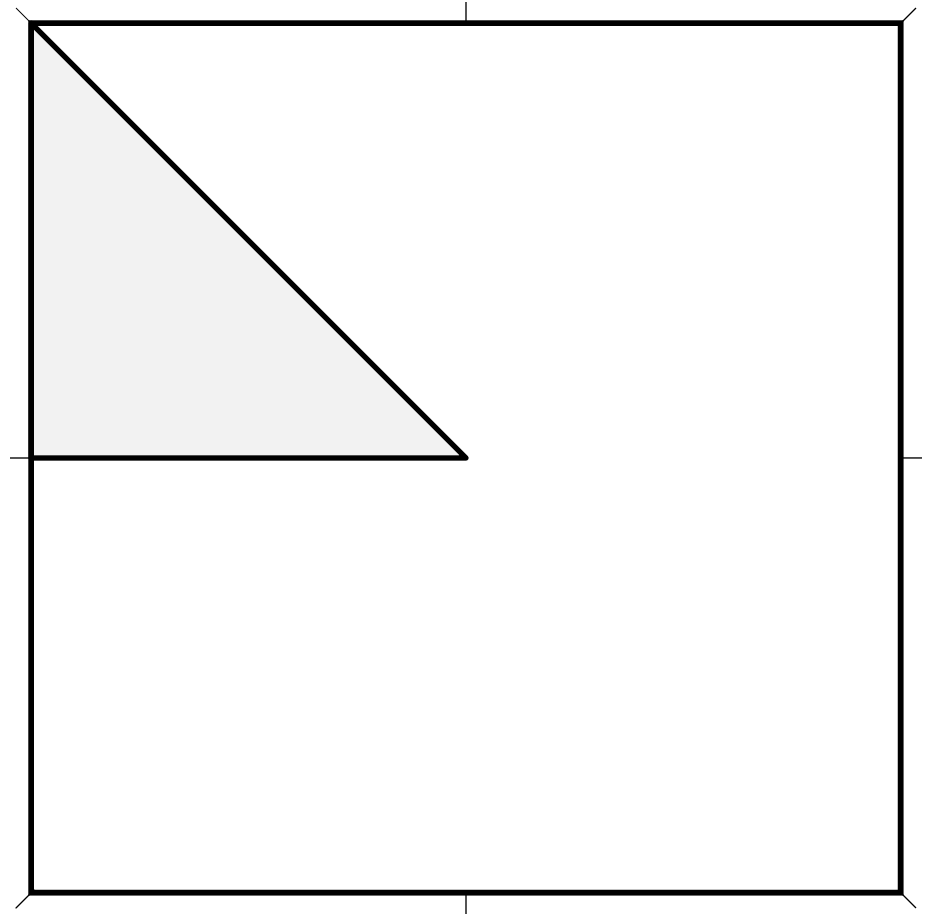
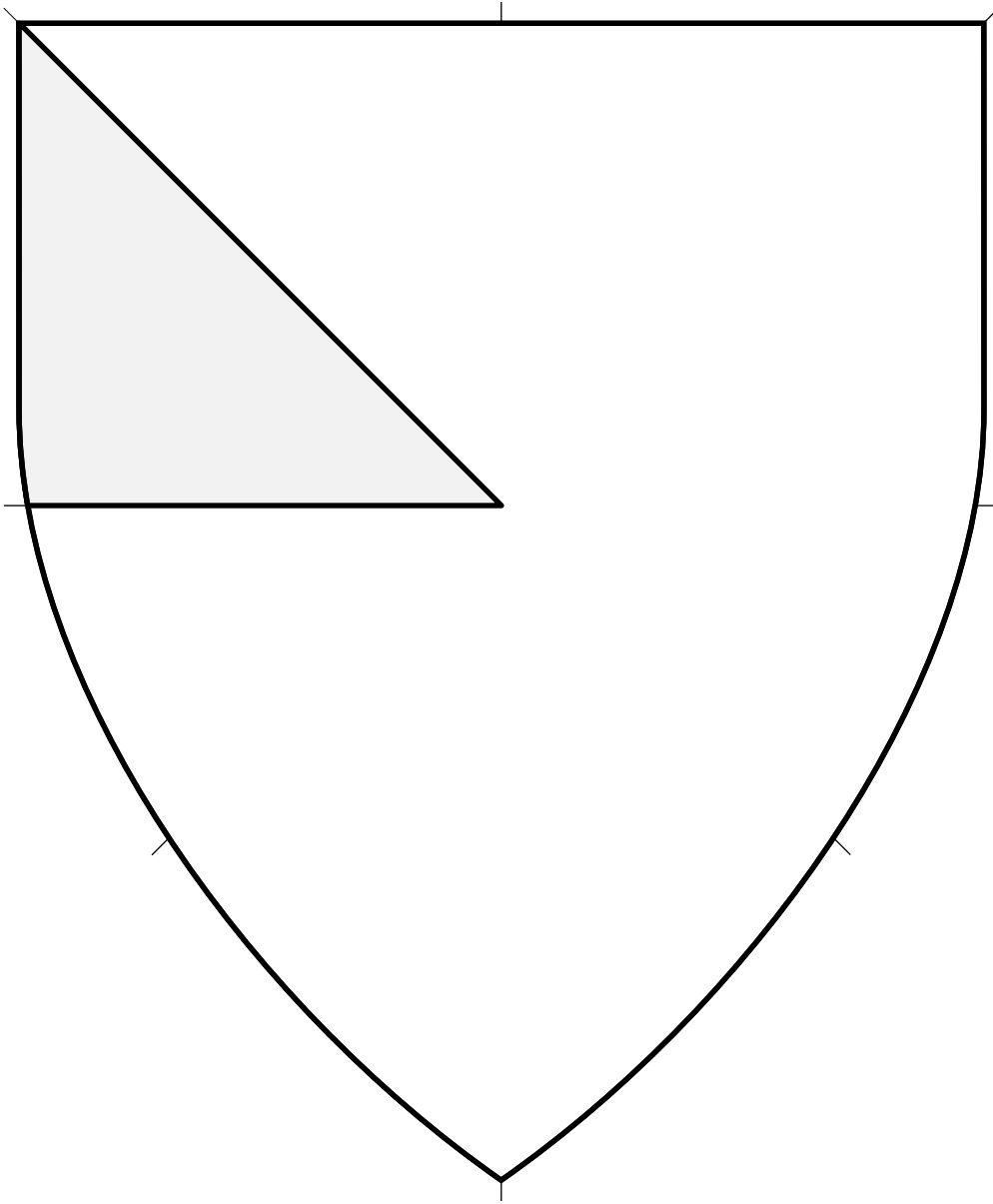

Peripheral ordinary. Triangle protruding from dexter side of one upper corner.

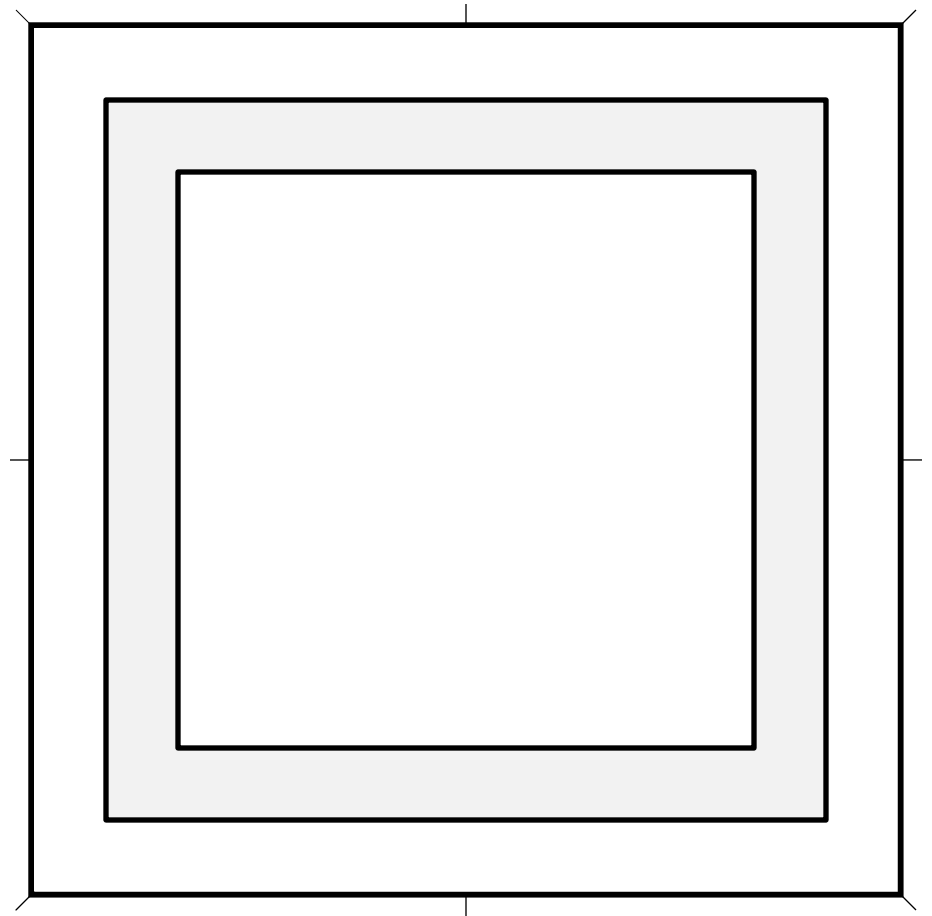
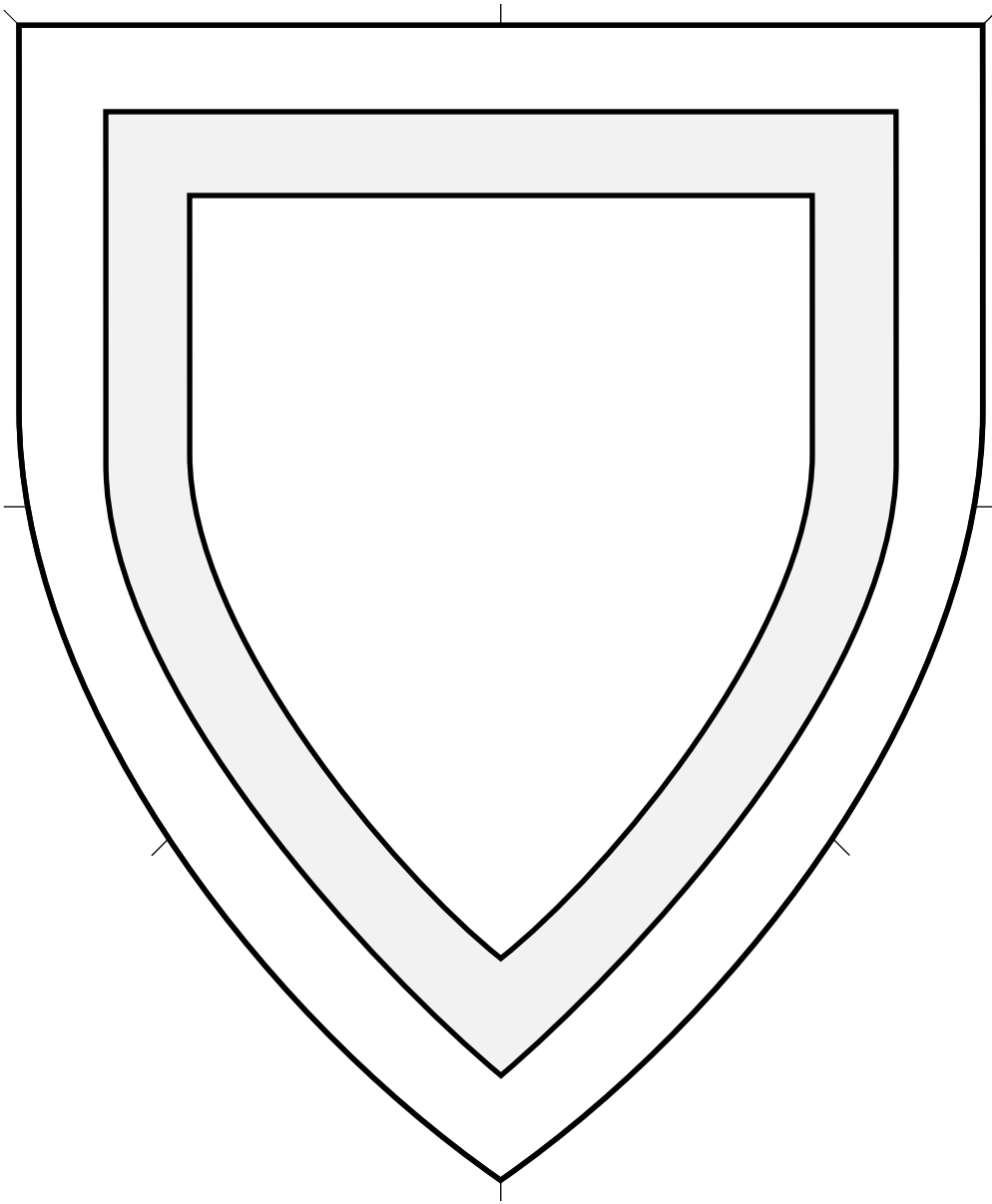

Peripheral ordinary. The thickness of the stripe is typically around a twelfth of the width of the device, and spaced a similar distance from the edge.

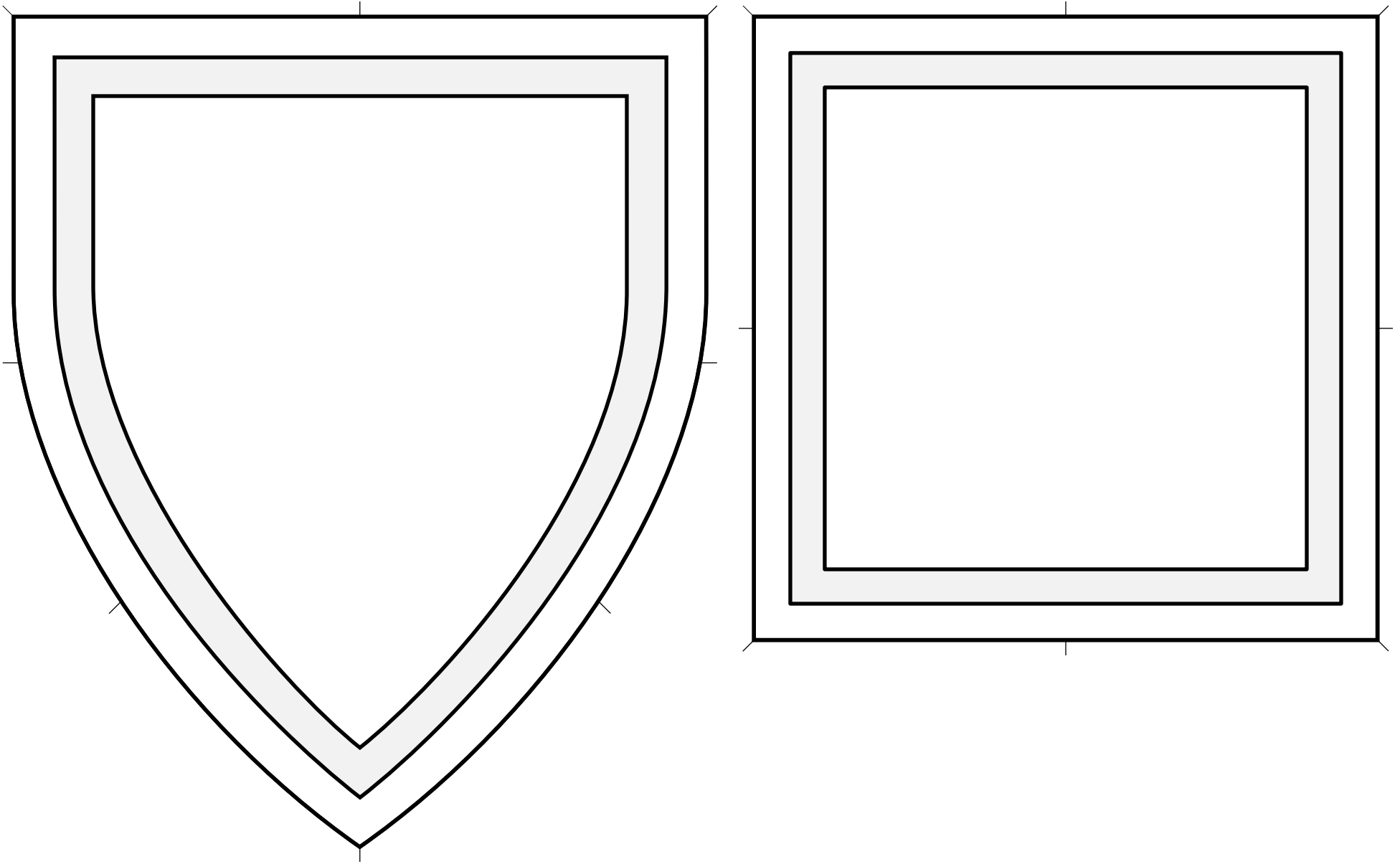

Peripheral ordinary. The thickness of the stripe is typically around a twelfth of the width of the device, and spaced a similar distance from the edge.

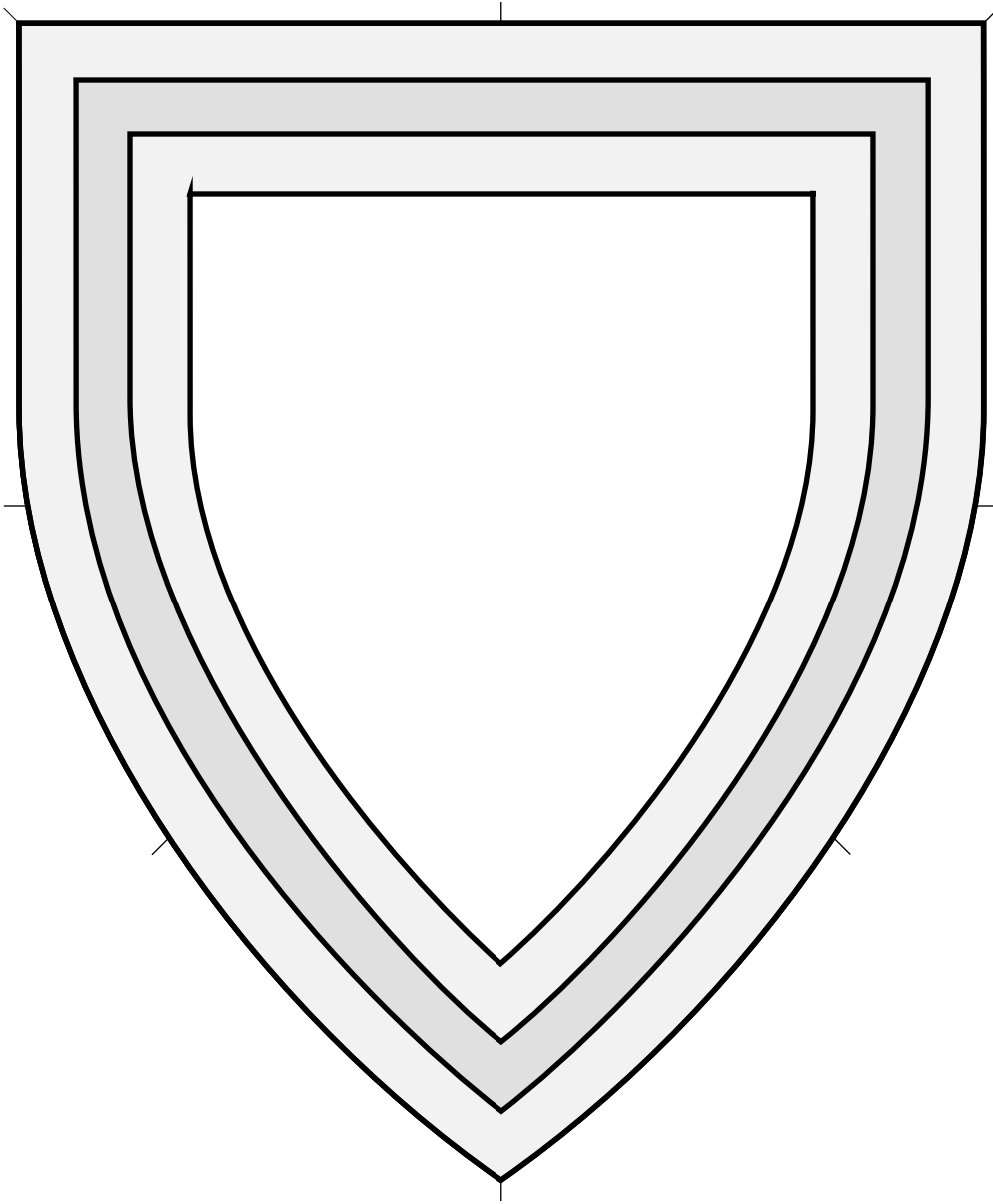

Peripheral ordinary.

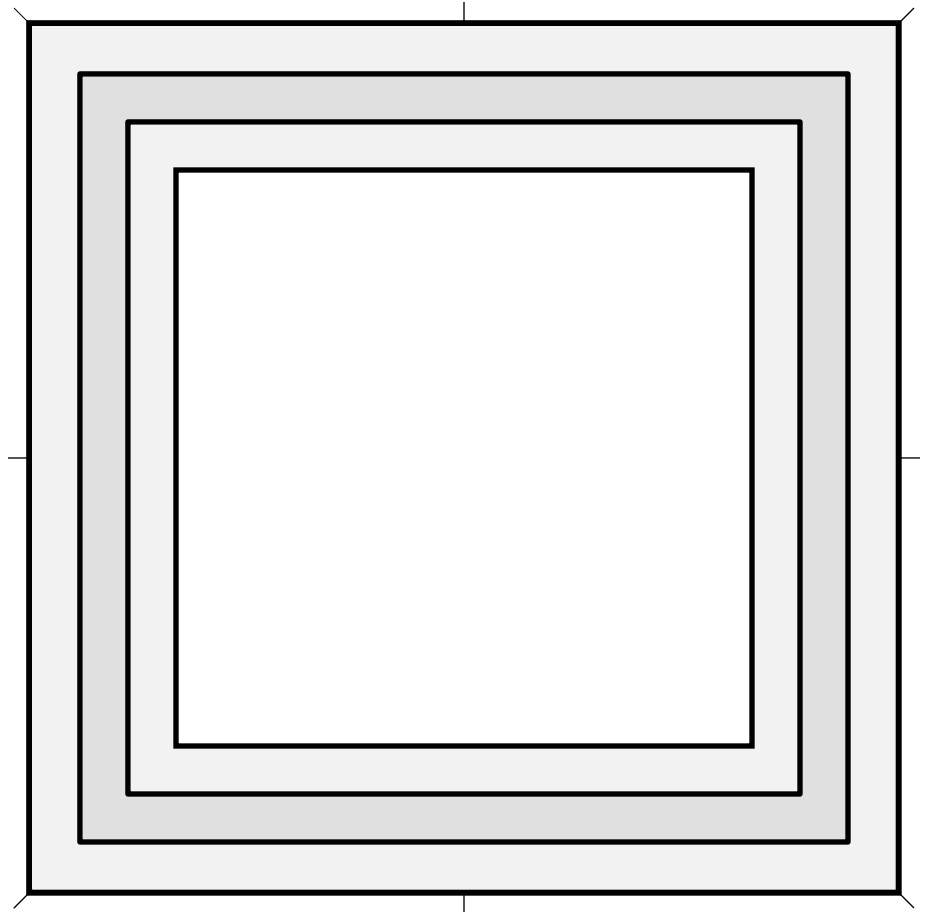

Orle on a Bordure 4.465

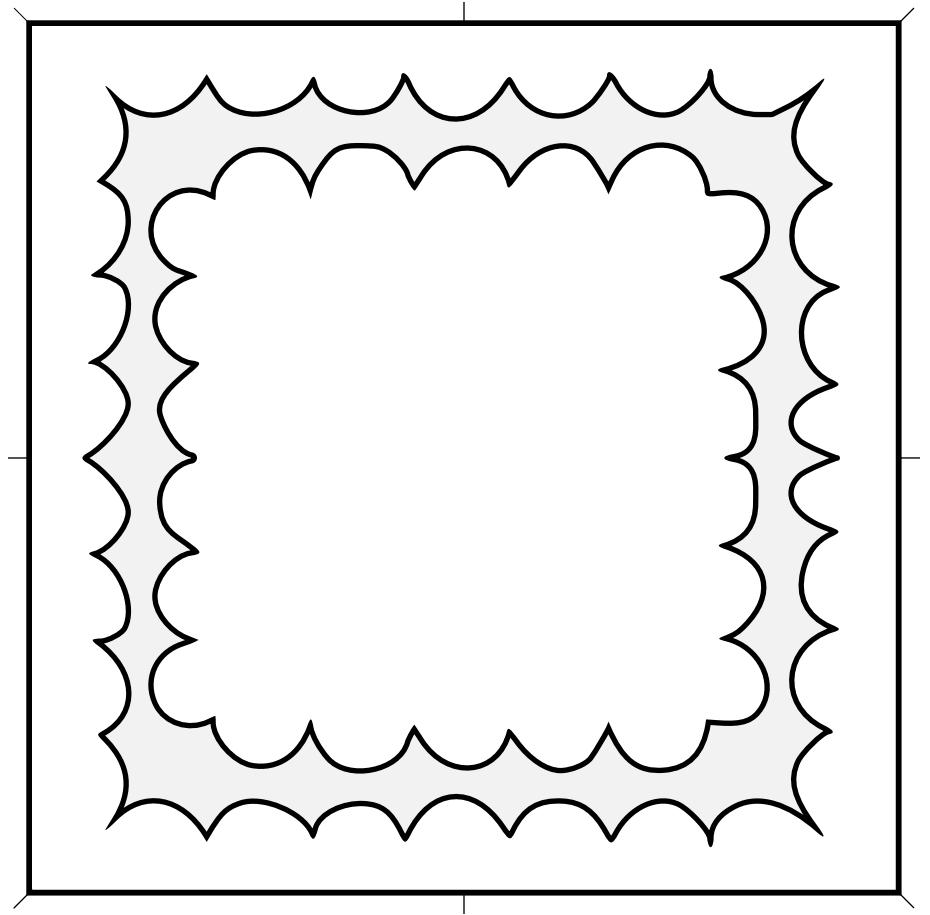
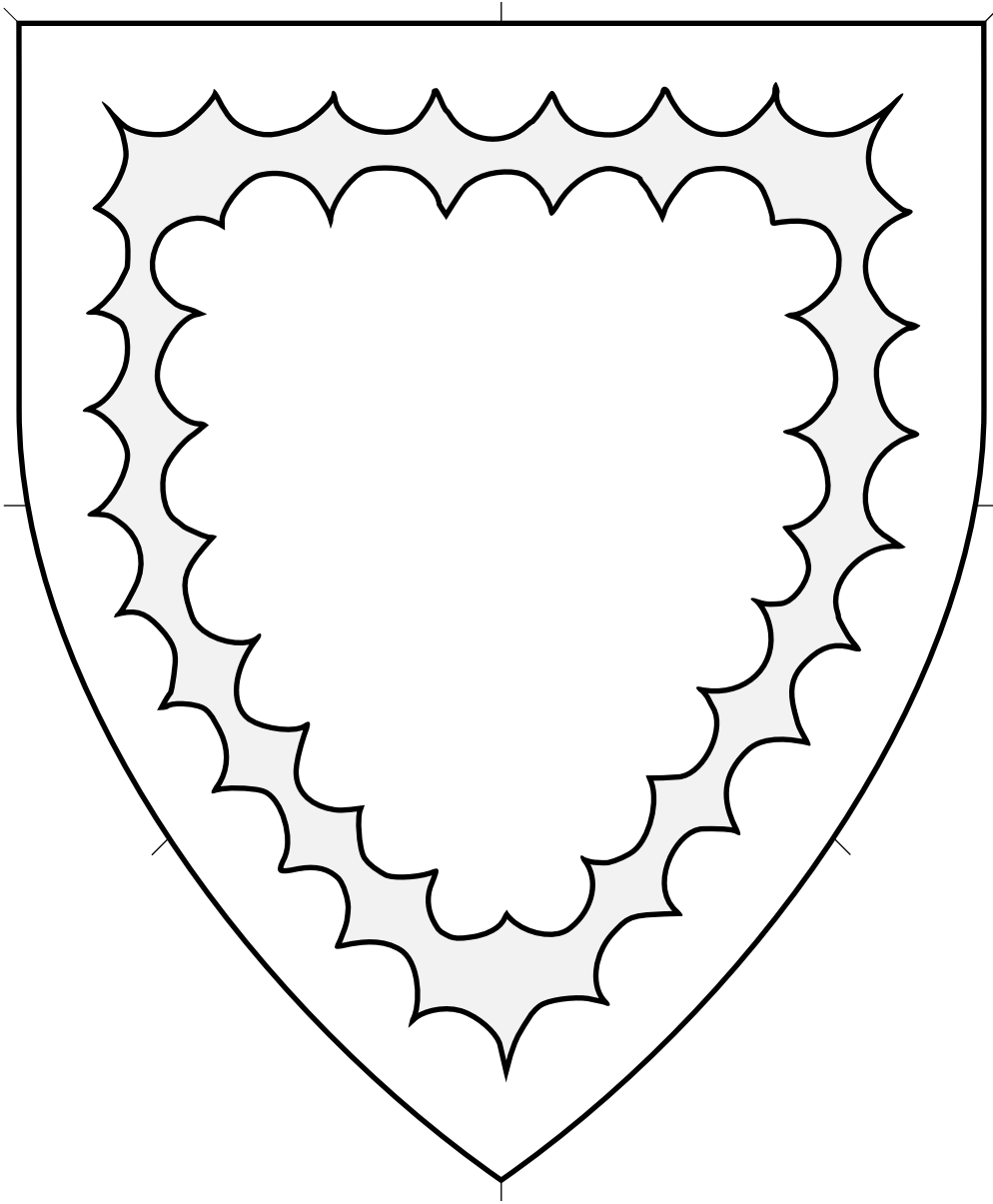

Peripheral ordinary.

Source: Pennsic Herald's Point Artists. Artist: Kryss Kostarev.

Orle Engrailed 4.466

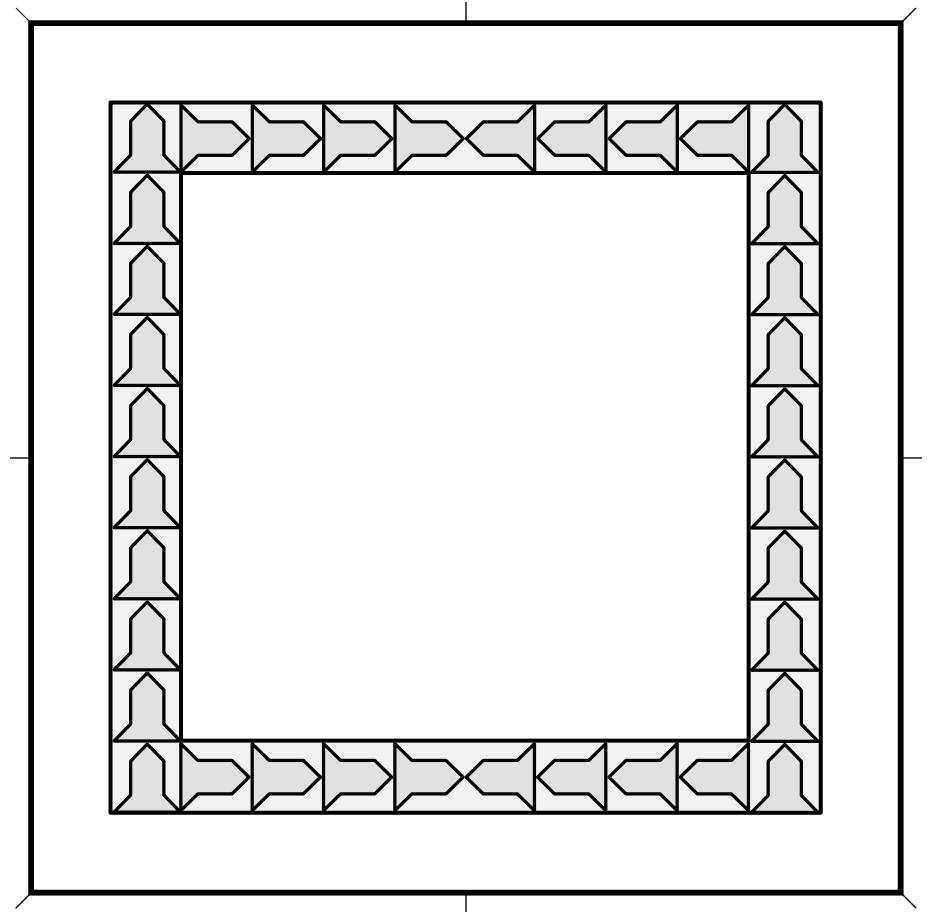
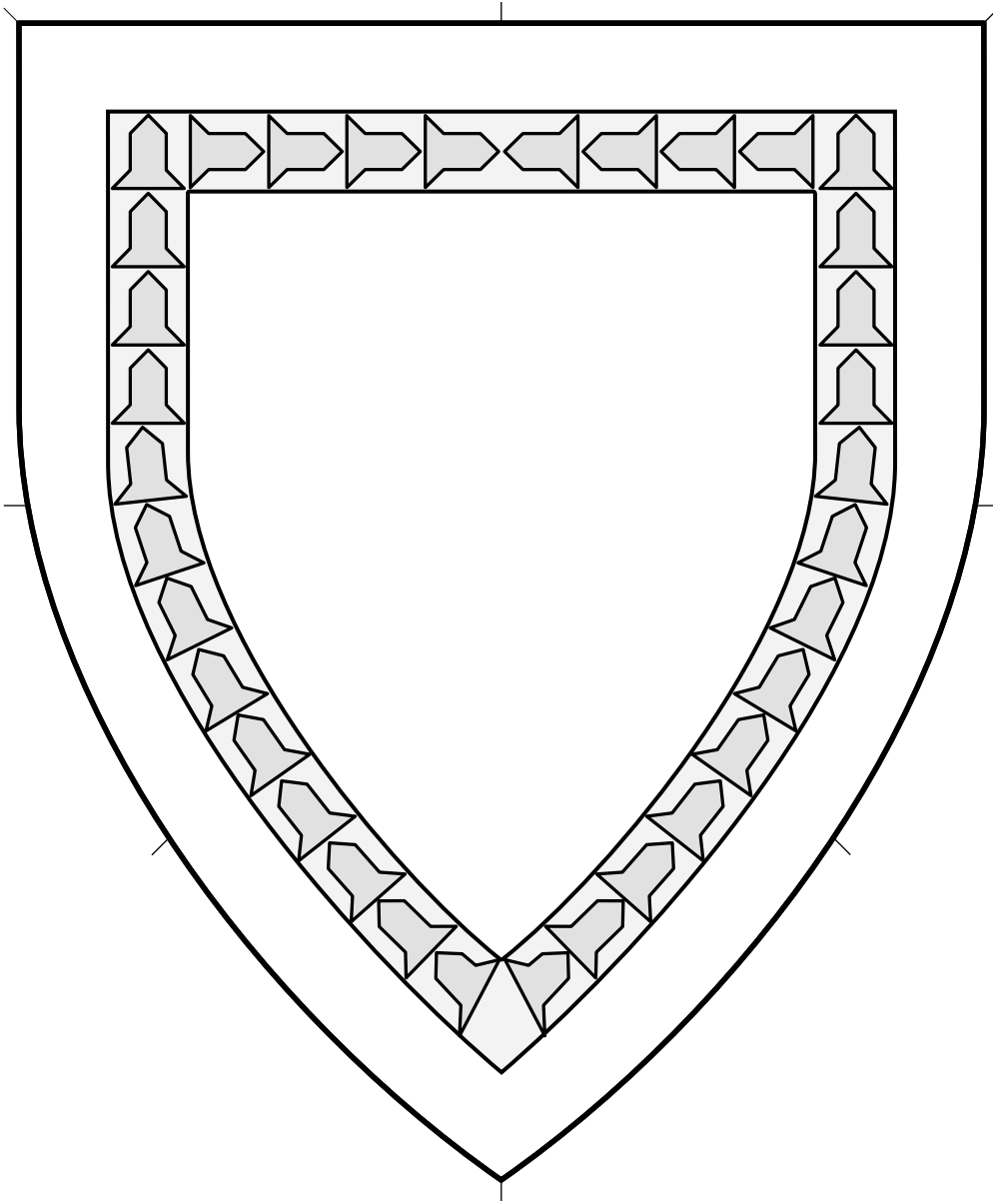

Peripheral ordinary.

Artist: Vémundr Syvursson. Adapted by Mathghamhain Ua Ruadháin.

Orle Vair 4.467

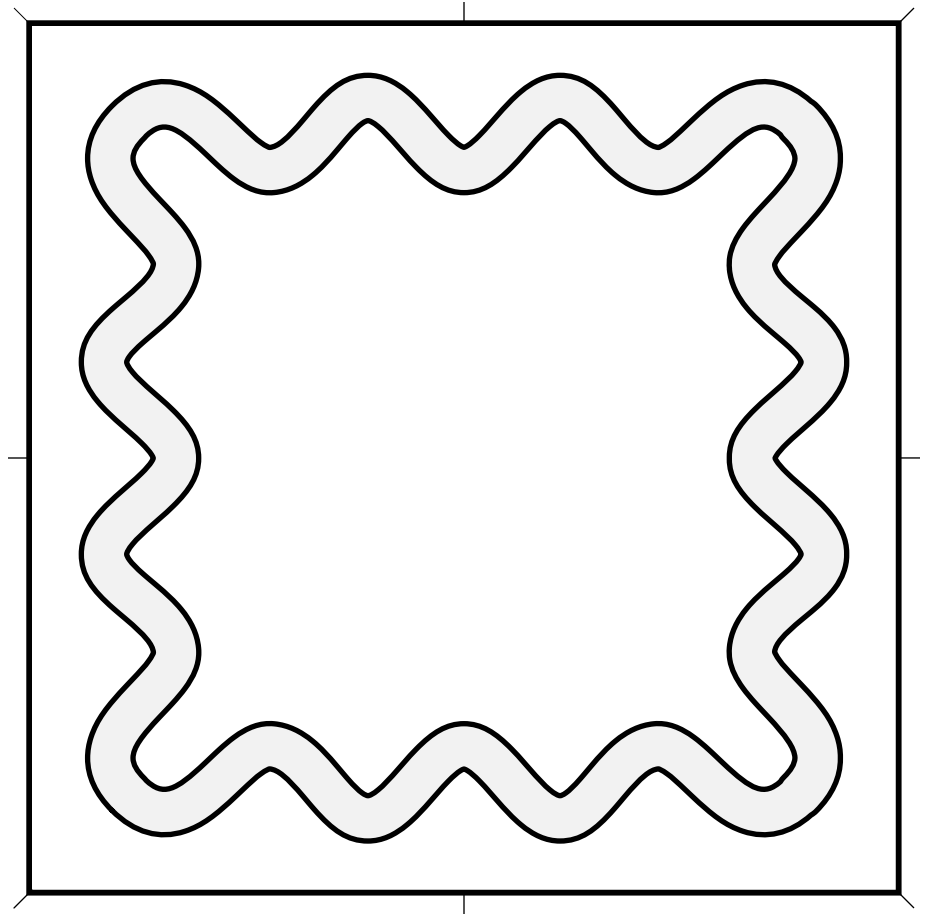
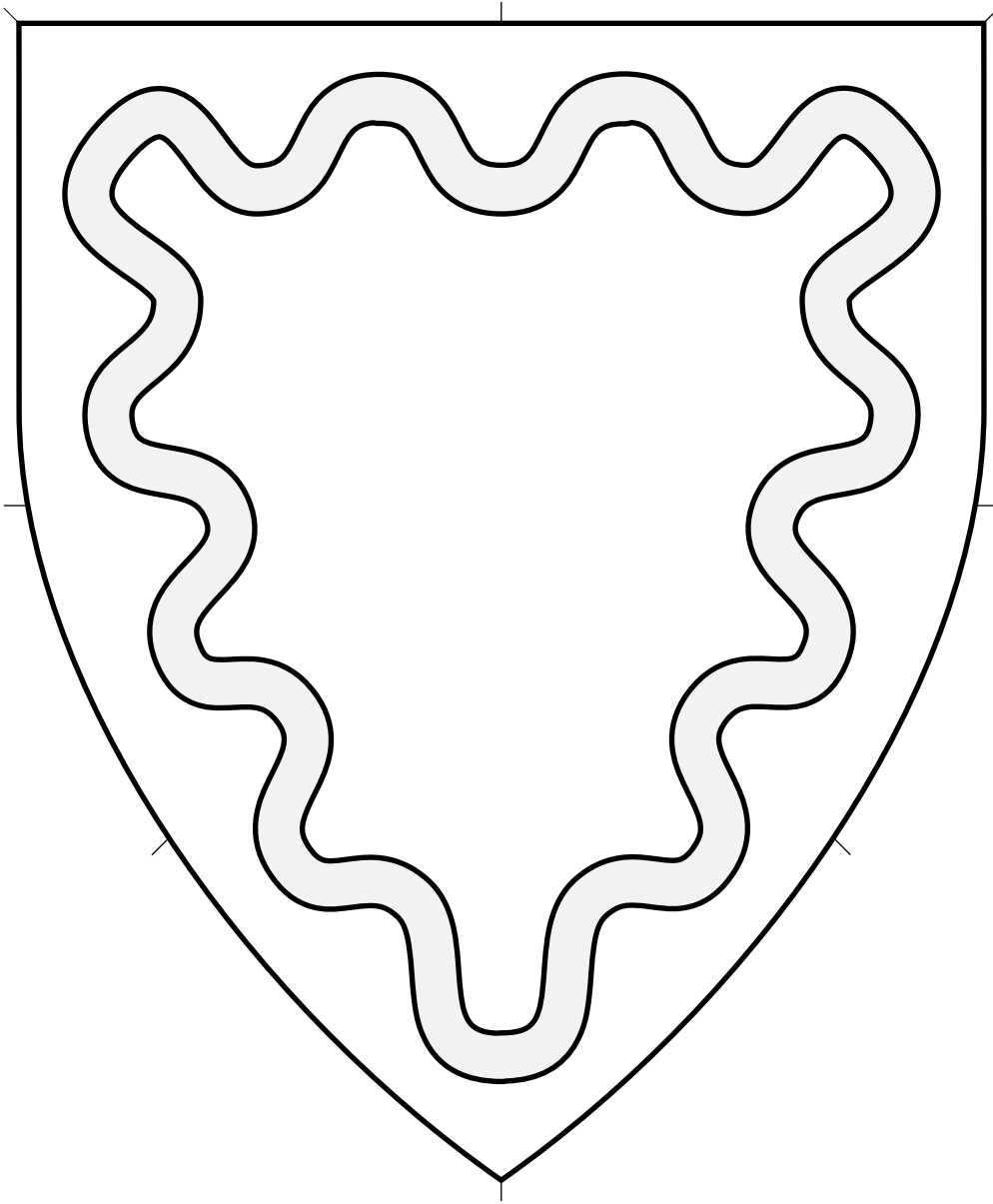

Peripheral ordinary.

Orle Wavy 4.468

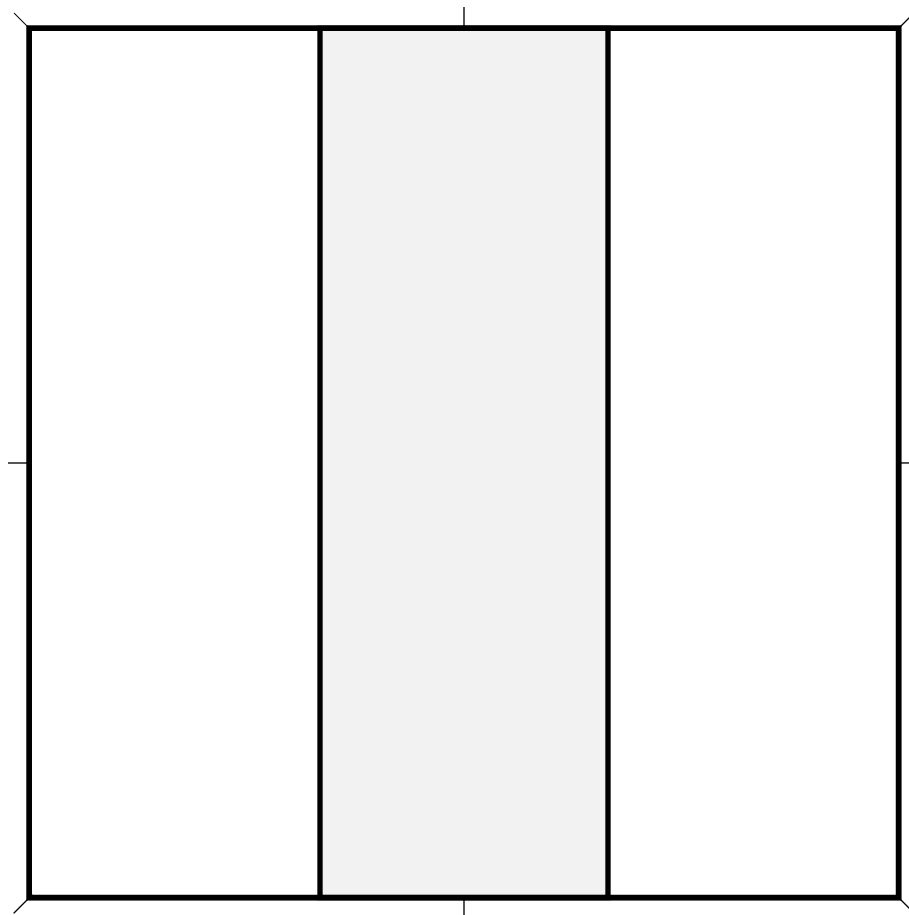
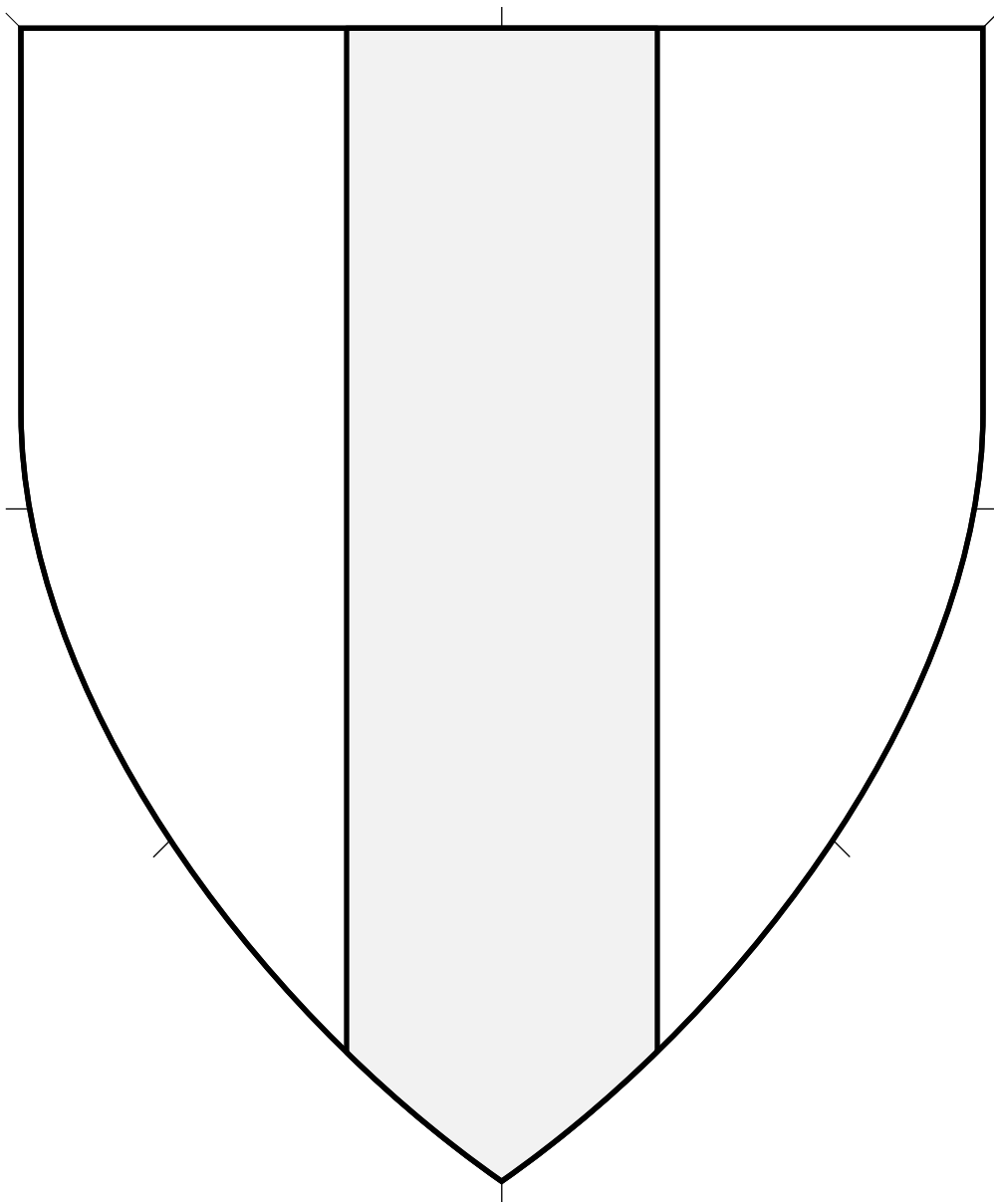

Central ordinary. Should be centered on the device.

The width is typically a third of the width of the device or a bit narrower. This is a thick pale.

Pale (1) 4.469

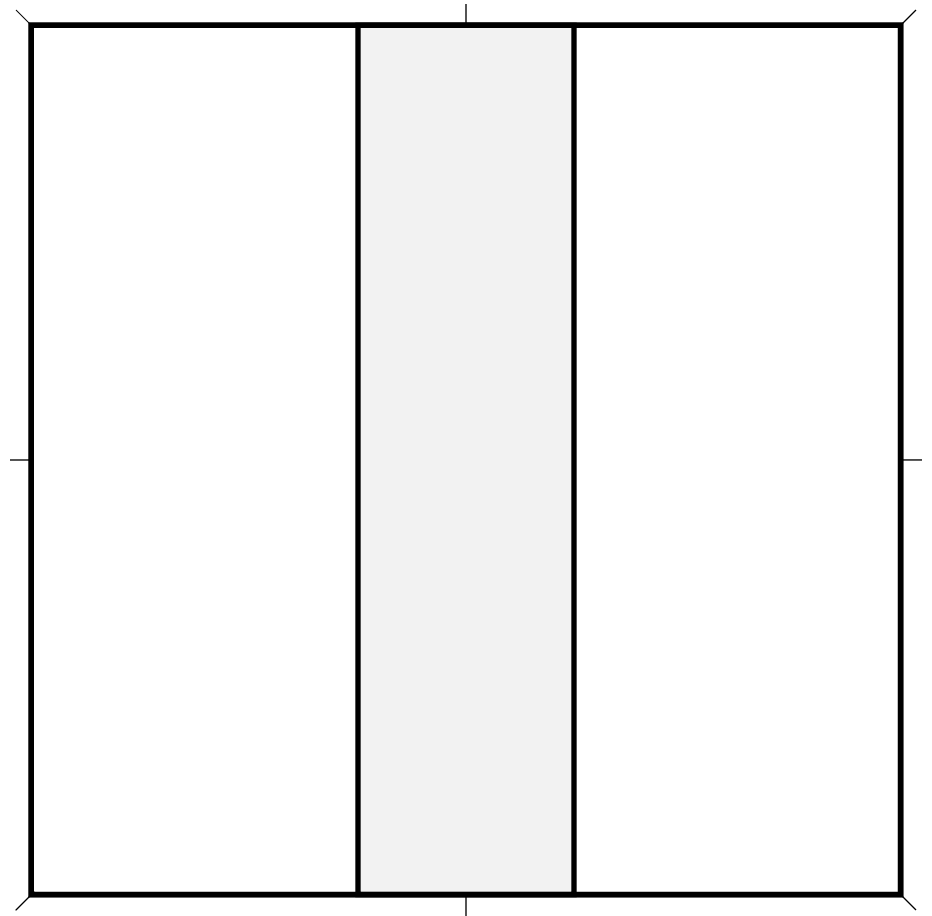
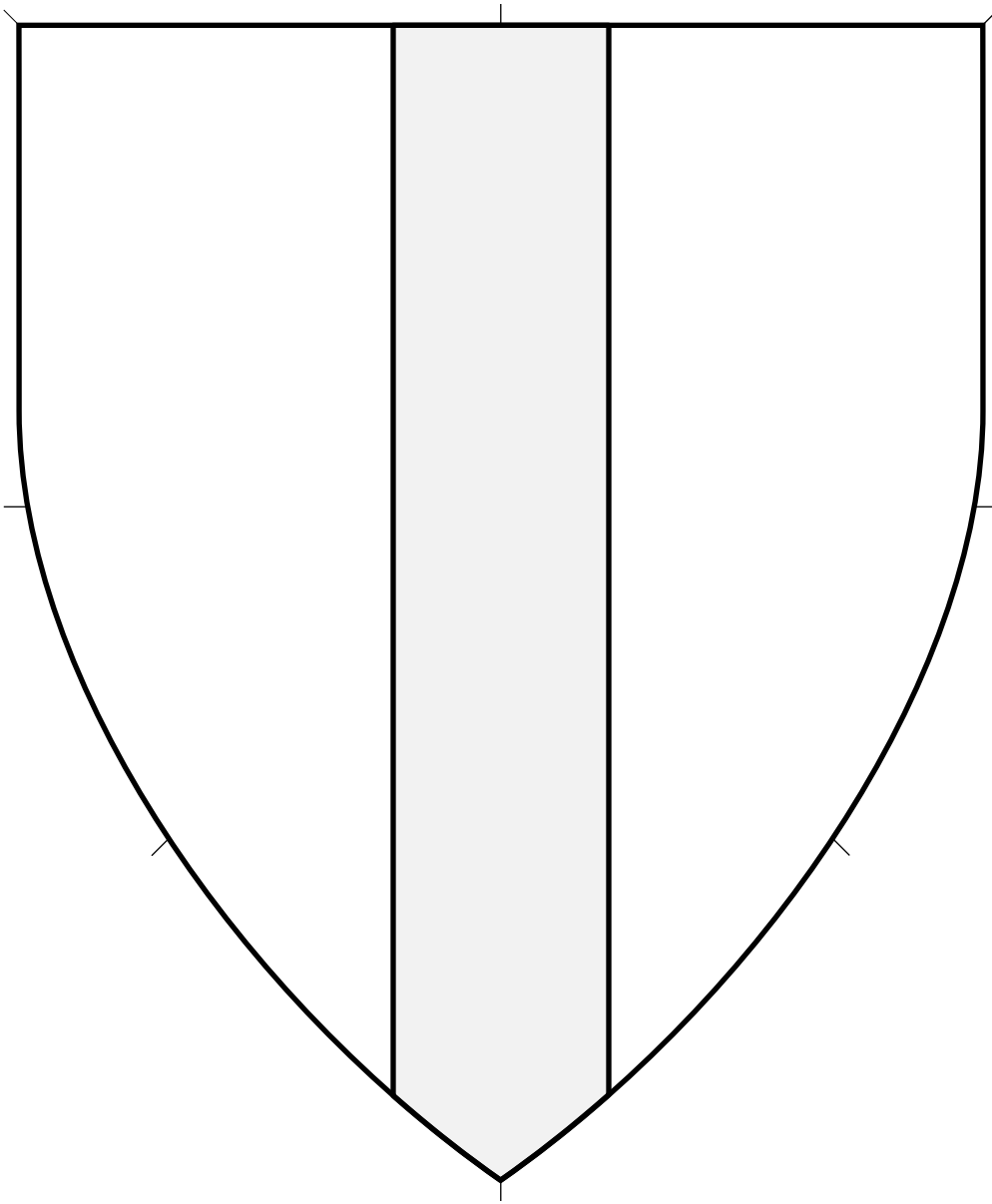

Central ordinary. Should be centered on the device.

The width is typically a third of the width of the device or a bit narrower. This is a thin pale.

Pale (2) 4.470

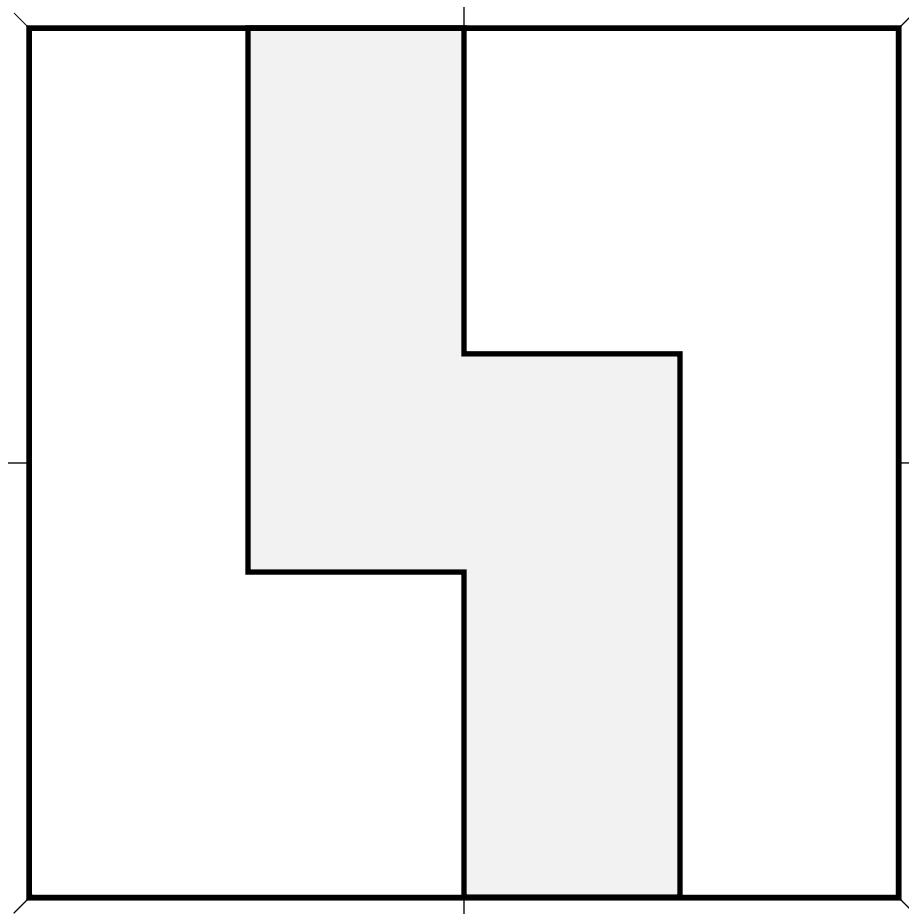
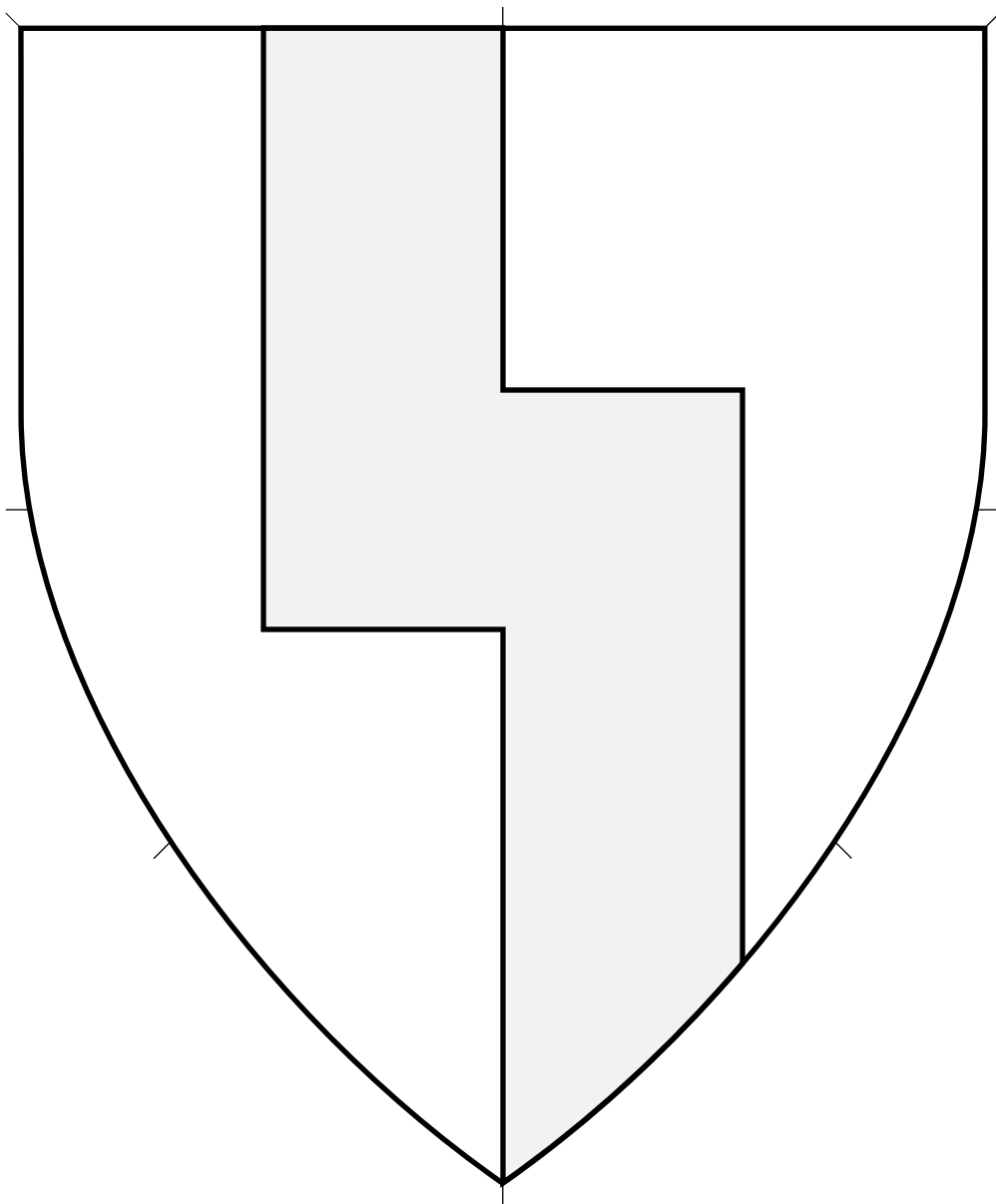

Central ordinary.

Source: Wappenbuch der Arlberg-Bruderschaft. Artist: Vigil Raber. (Page 640.)

Pale Angled • 4.471

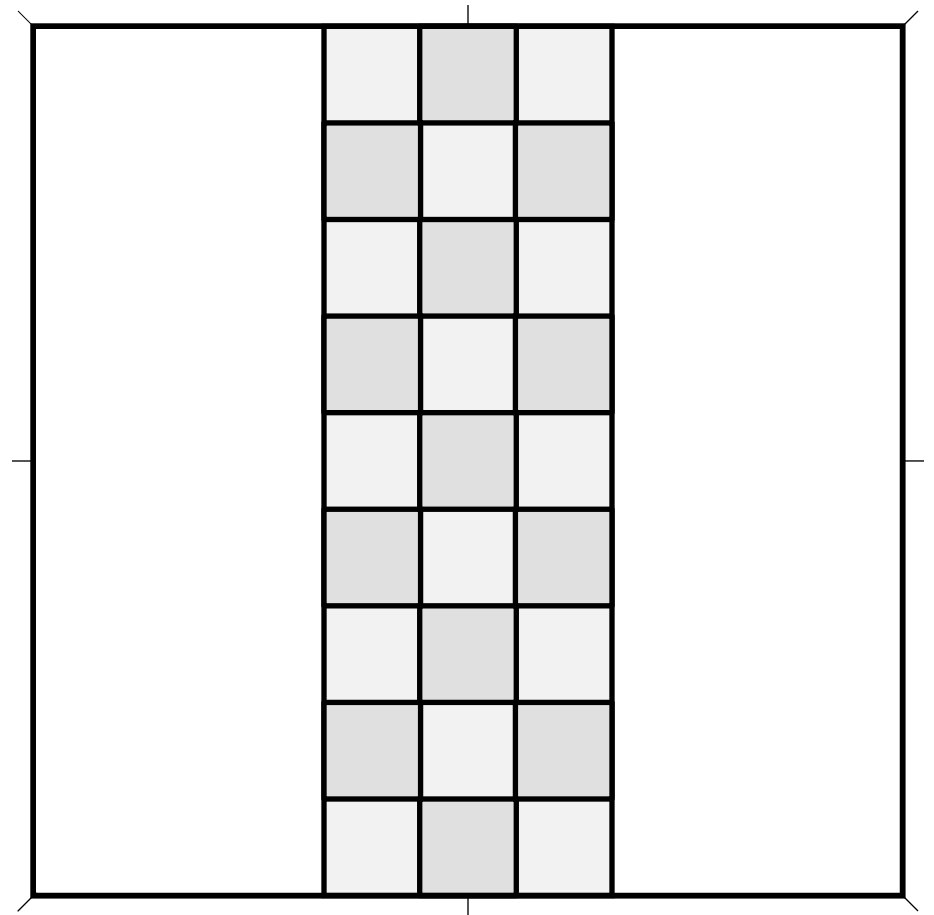
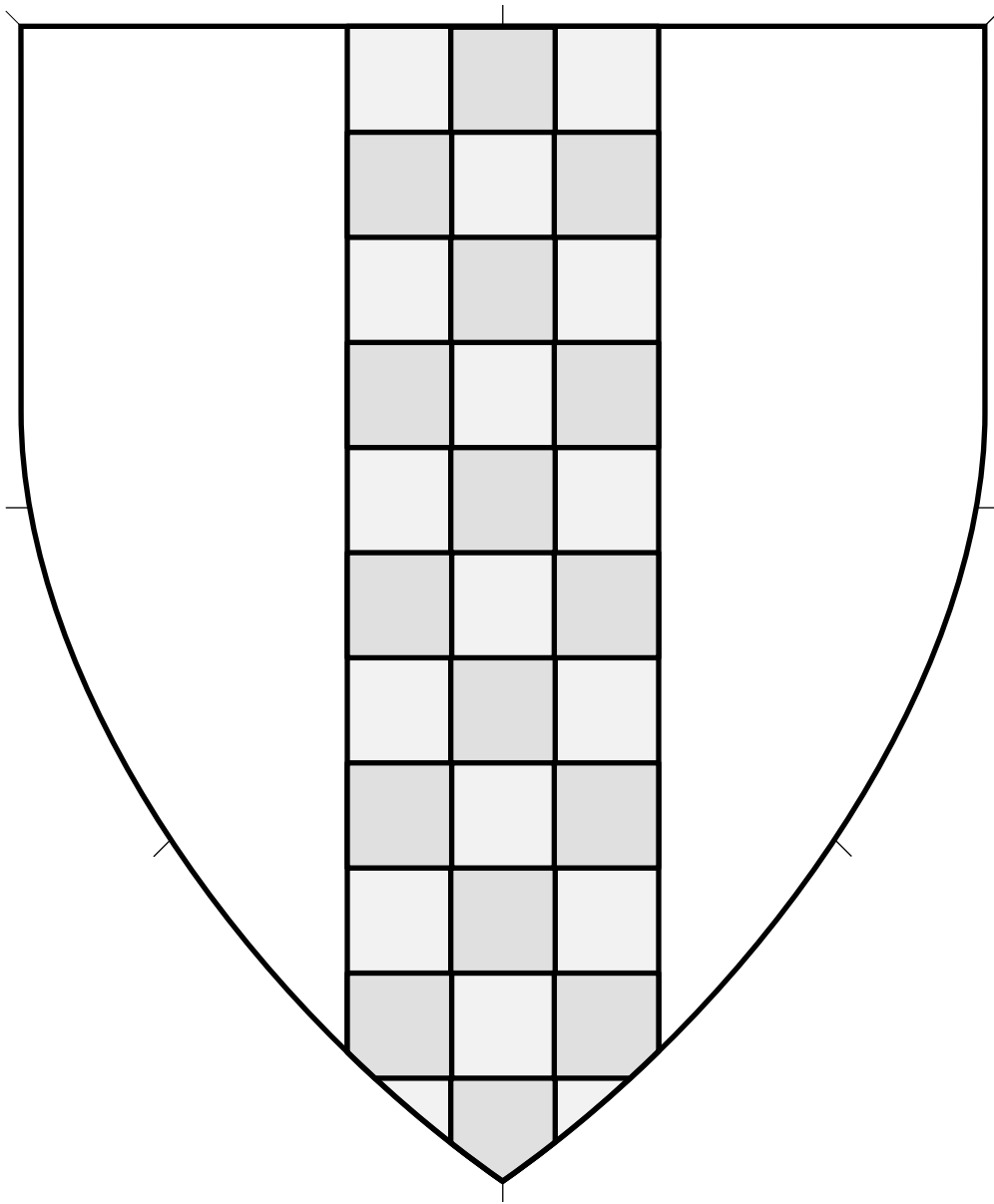

Central ordinary. Two contrasting tinctures.

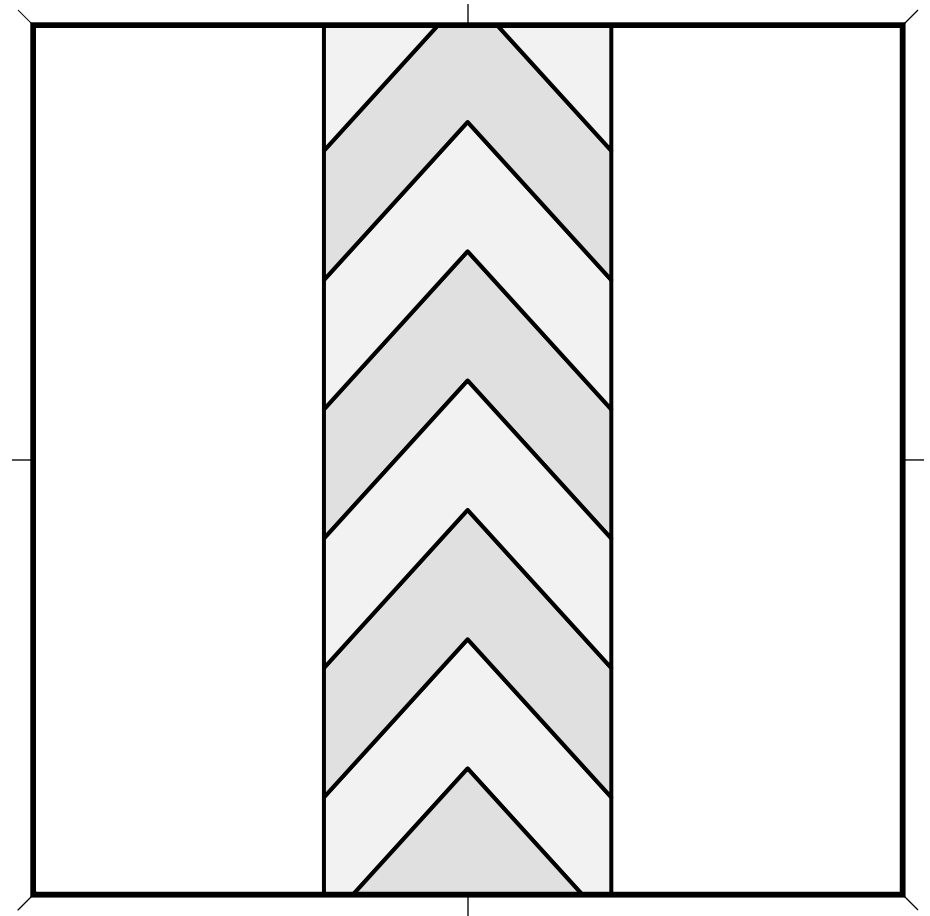
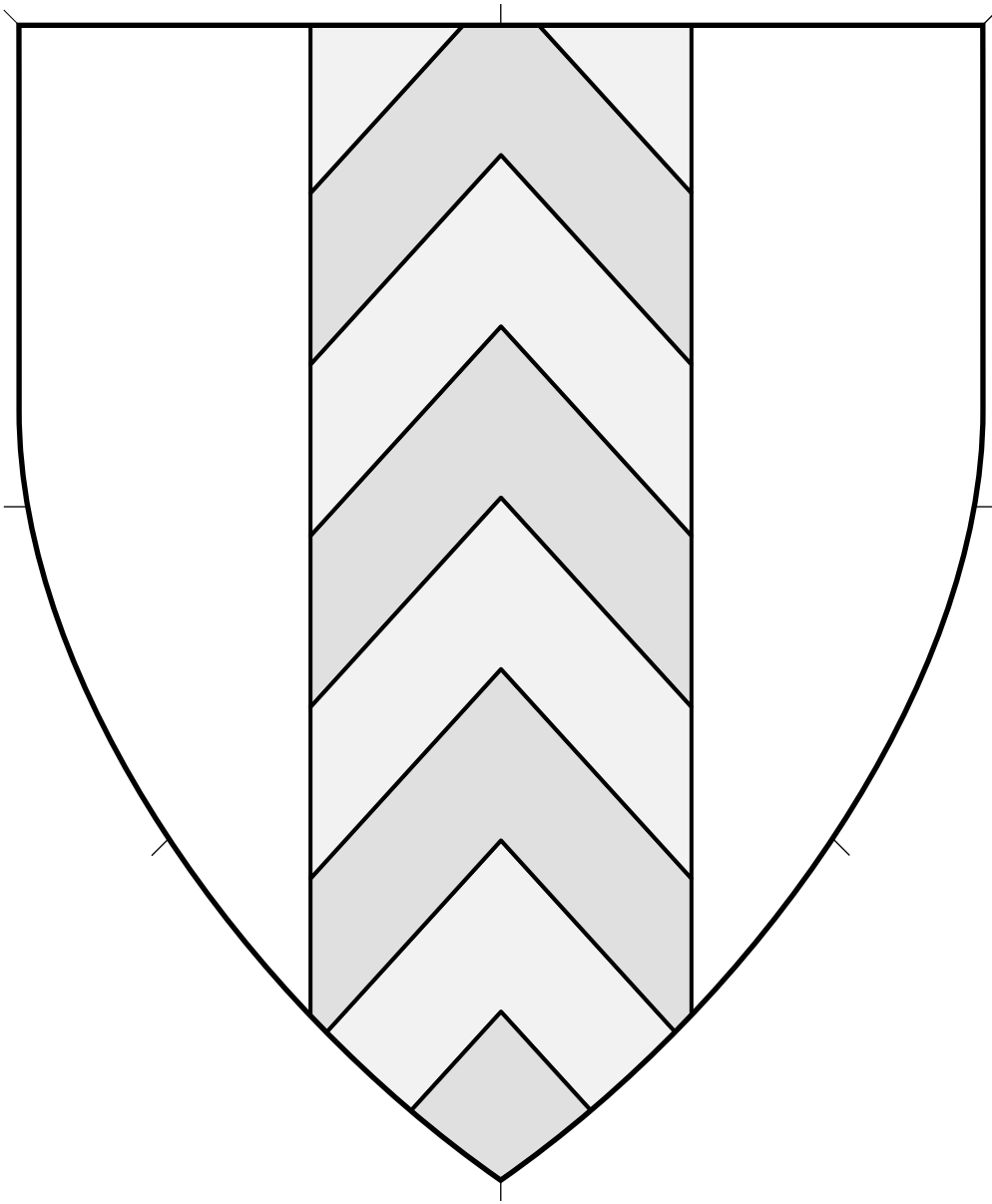

Central ordinary. Two contrasting tinctures.

Source: Insignia Pontificum Romanorum et Cardinalium I.
Artist unknown. (Folio 171r.)

Pale Chevronelly 4.473

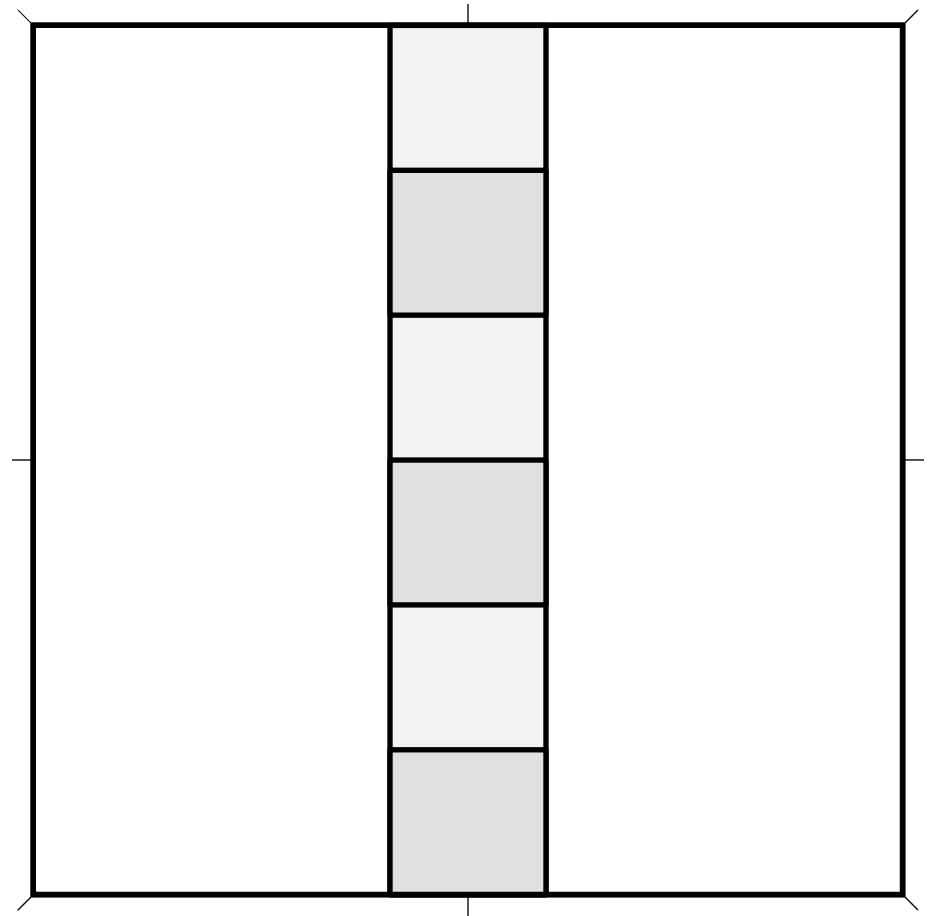
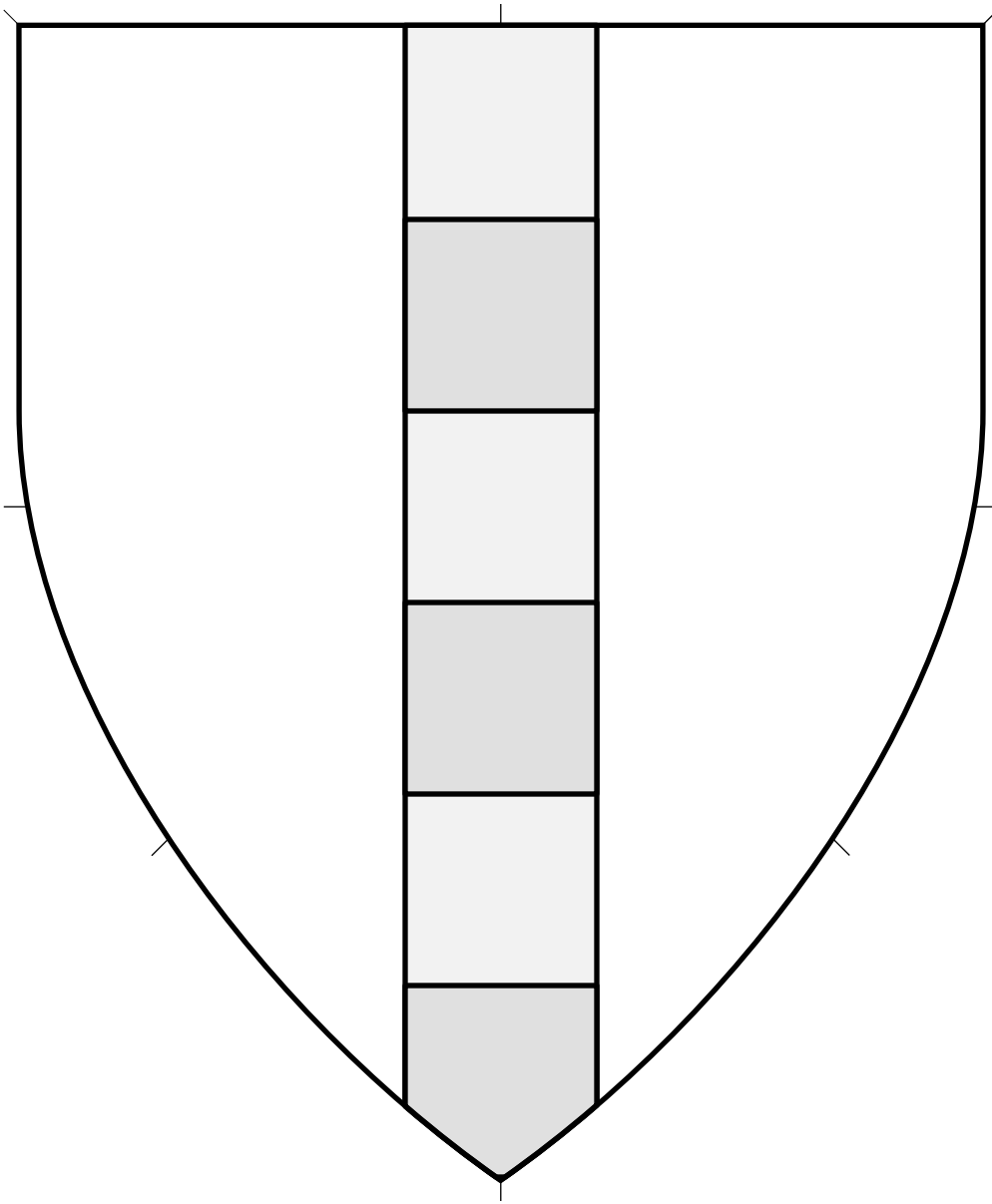

Central ordinary. Two contrasting tinctures.

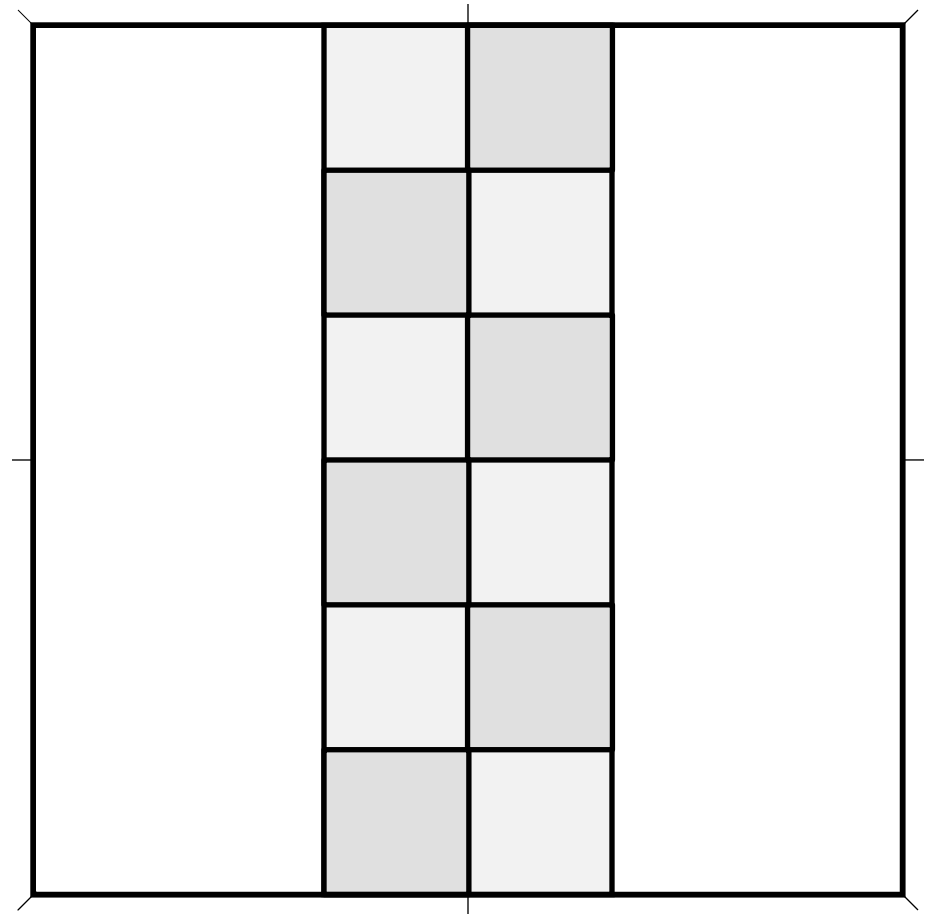
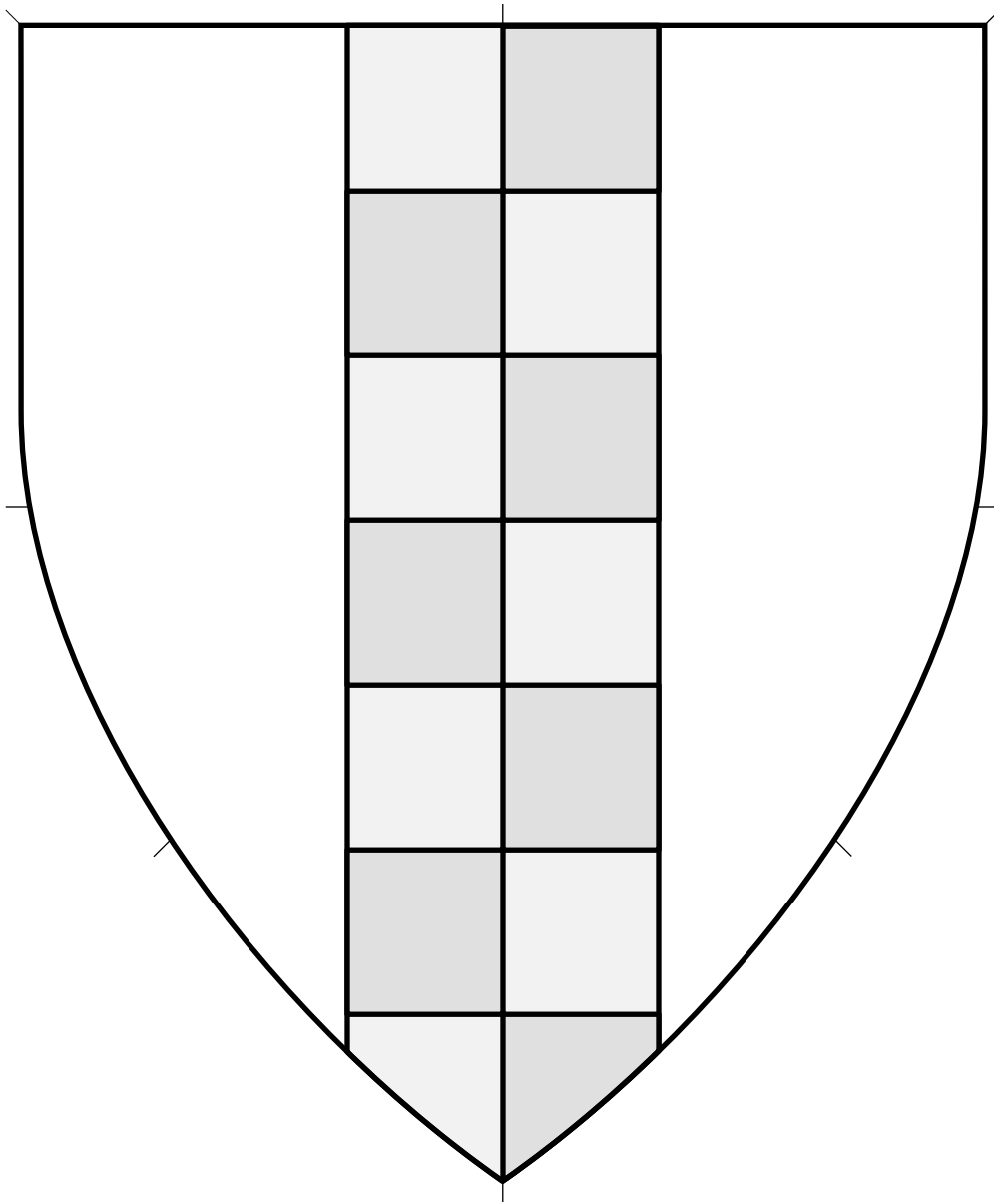

Central ordinary. Two contrasting tinctures.

Pale Counter-compony 4.475

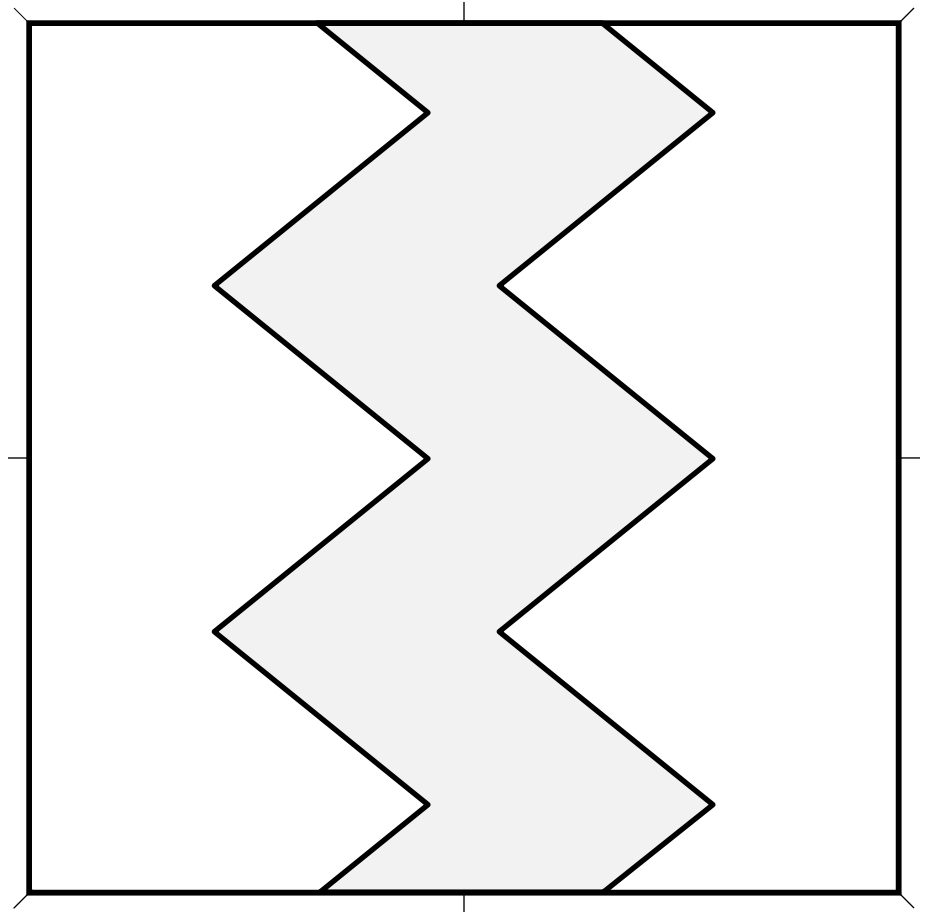
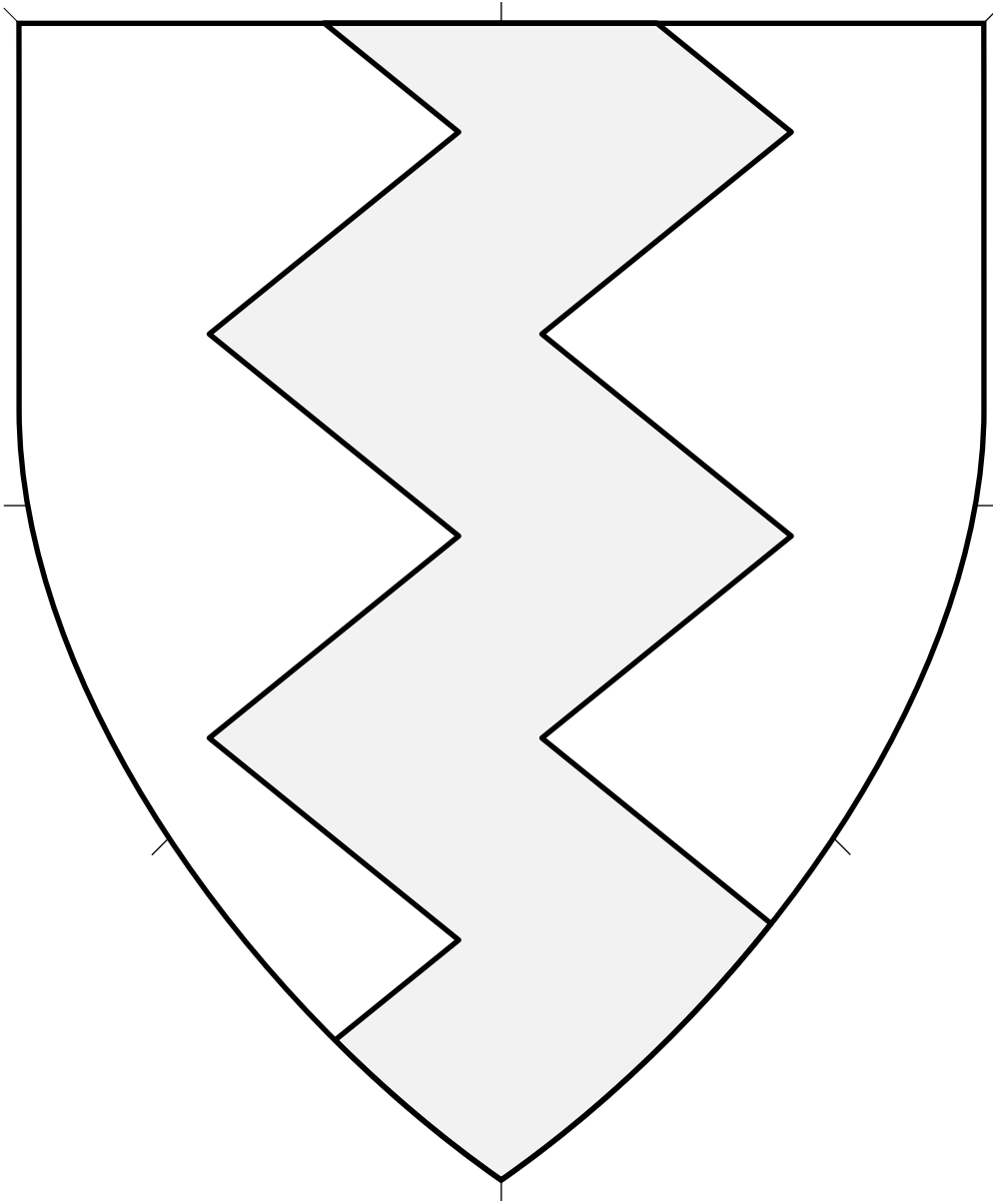

Central ordinary.
Artist: Sadhbh Bheag.

Pale Dancetty • 4.476

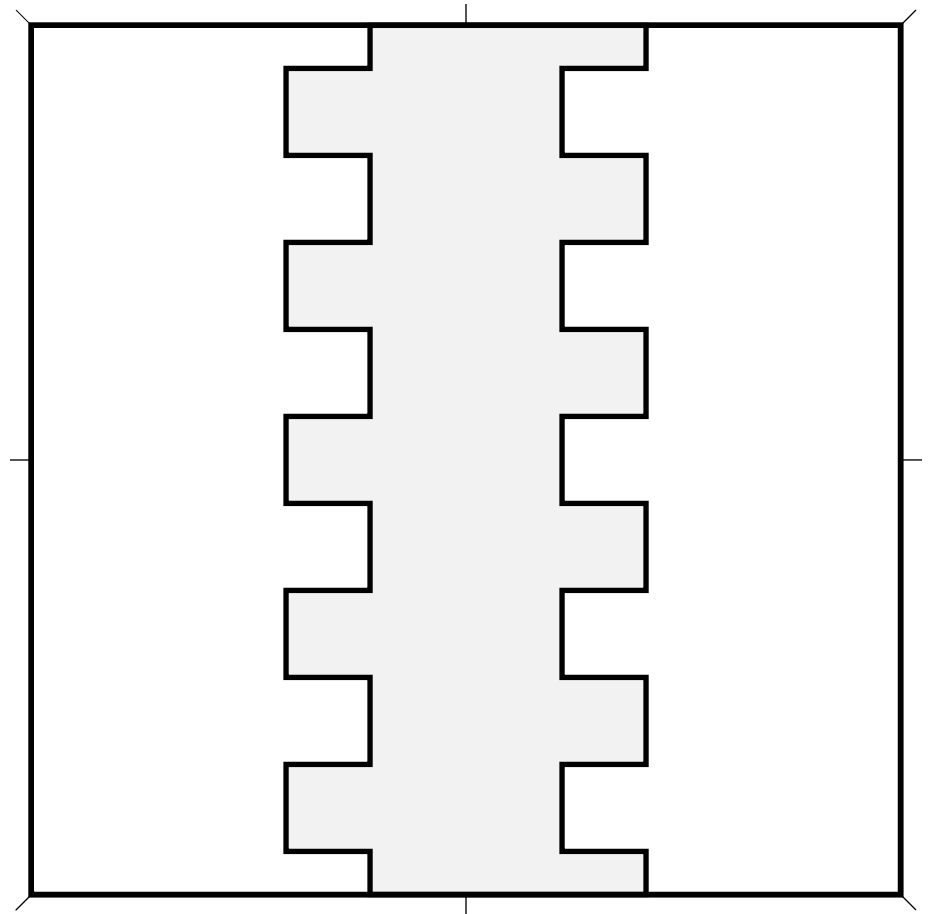
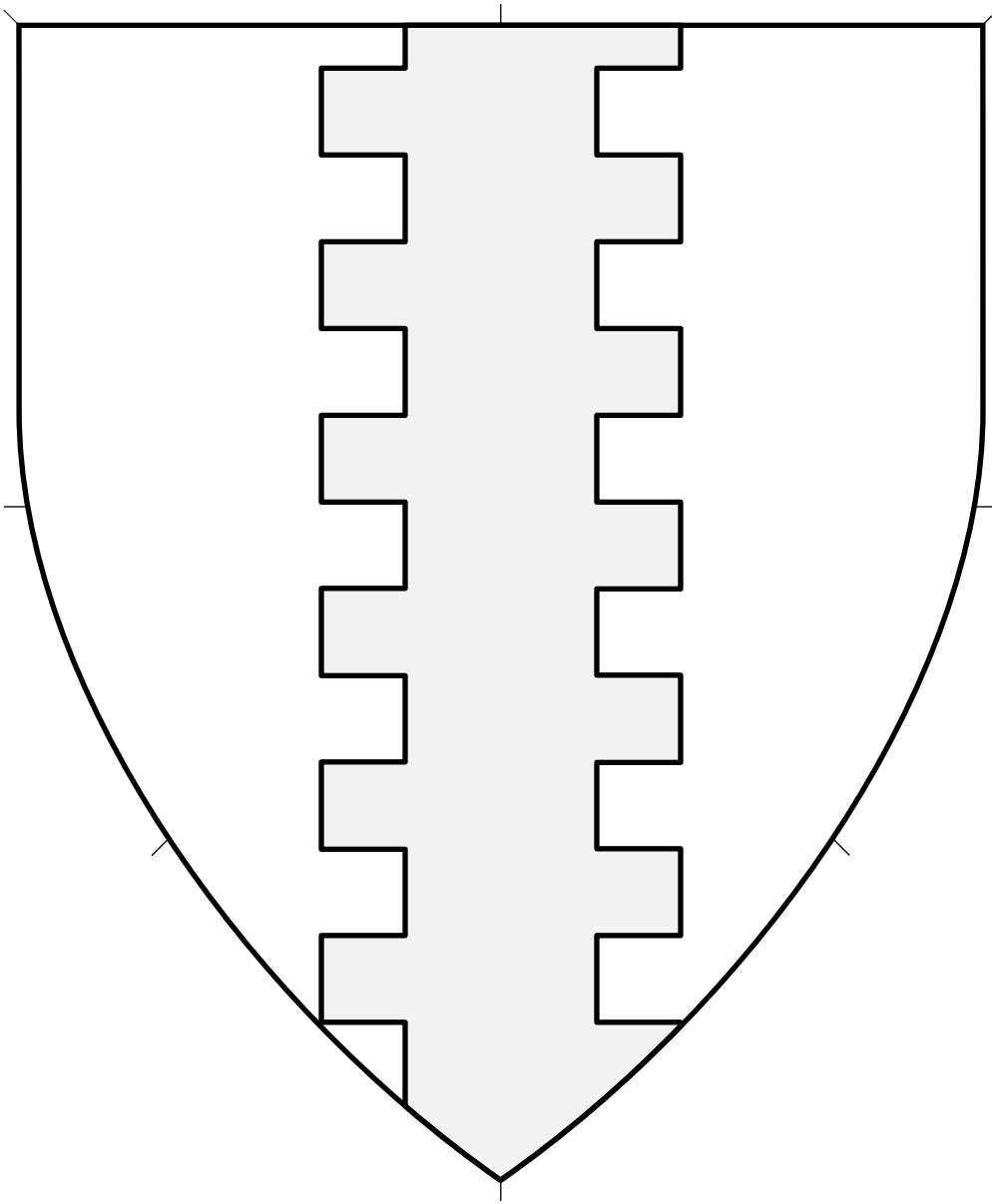

Central ordinary. Should be centered on the device.

Pale Embattled (1) 4.477

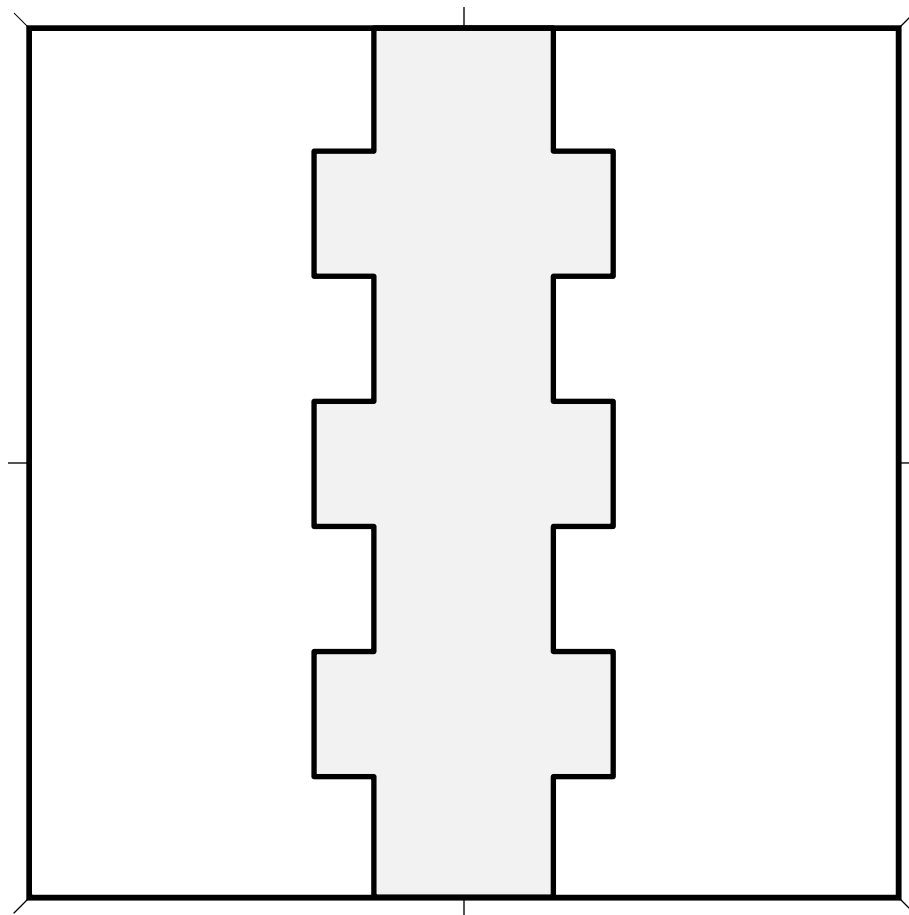
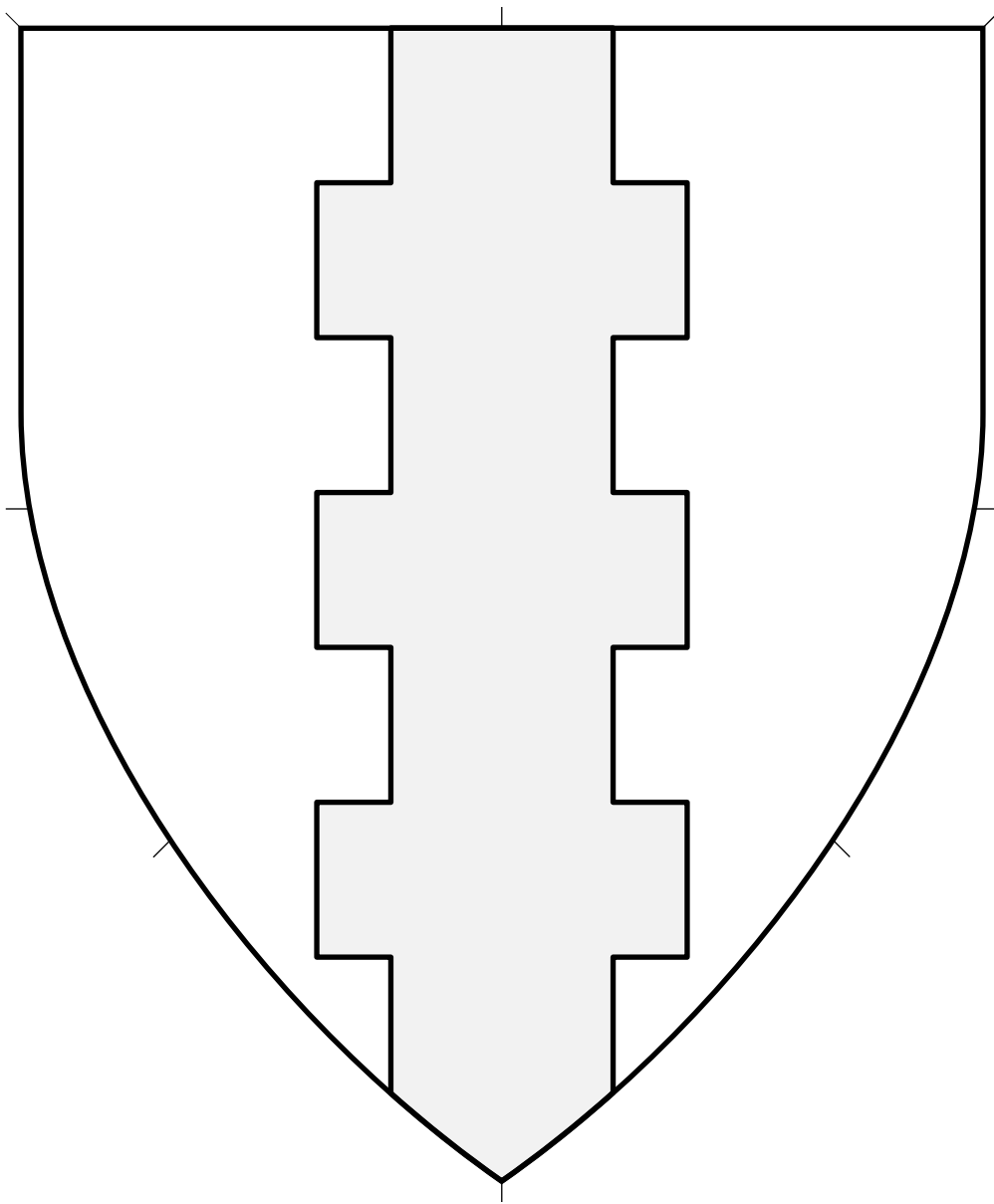

Central ordinary.

Source: English Arms A. Artist unknown. (Page 67.)

Pale Embattled (2) 4.478

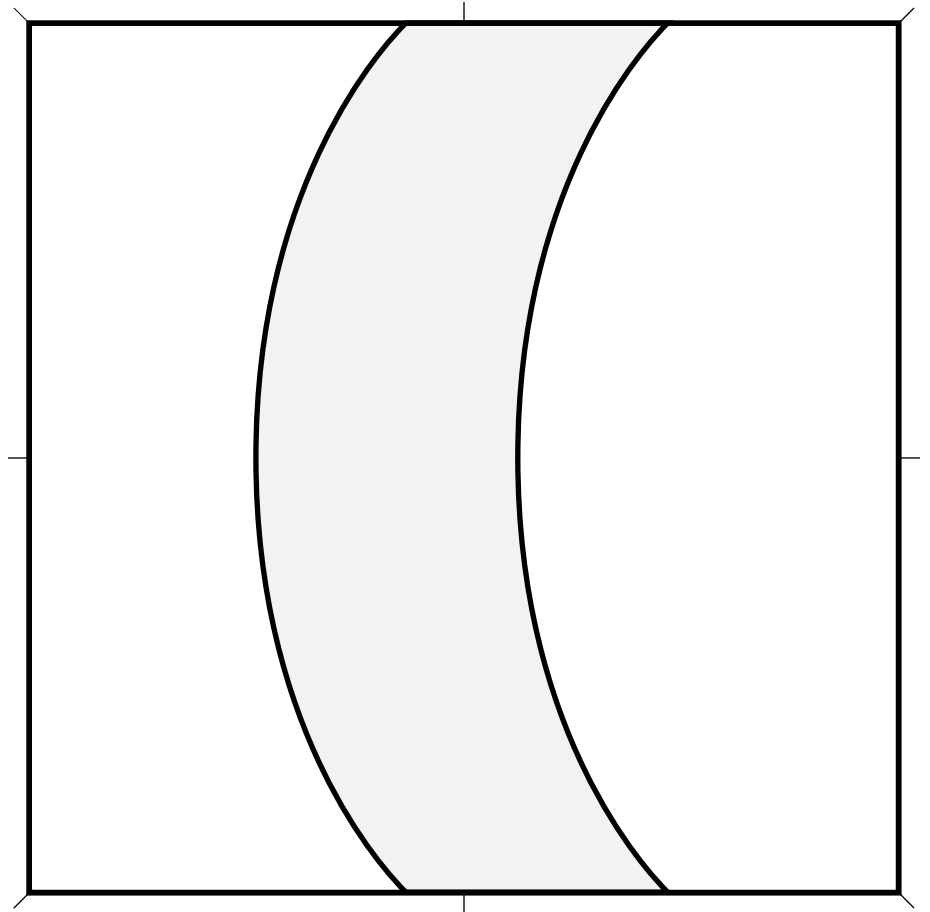
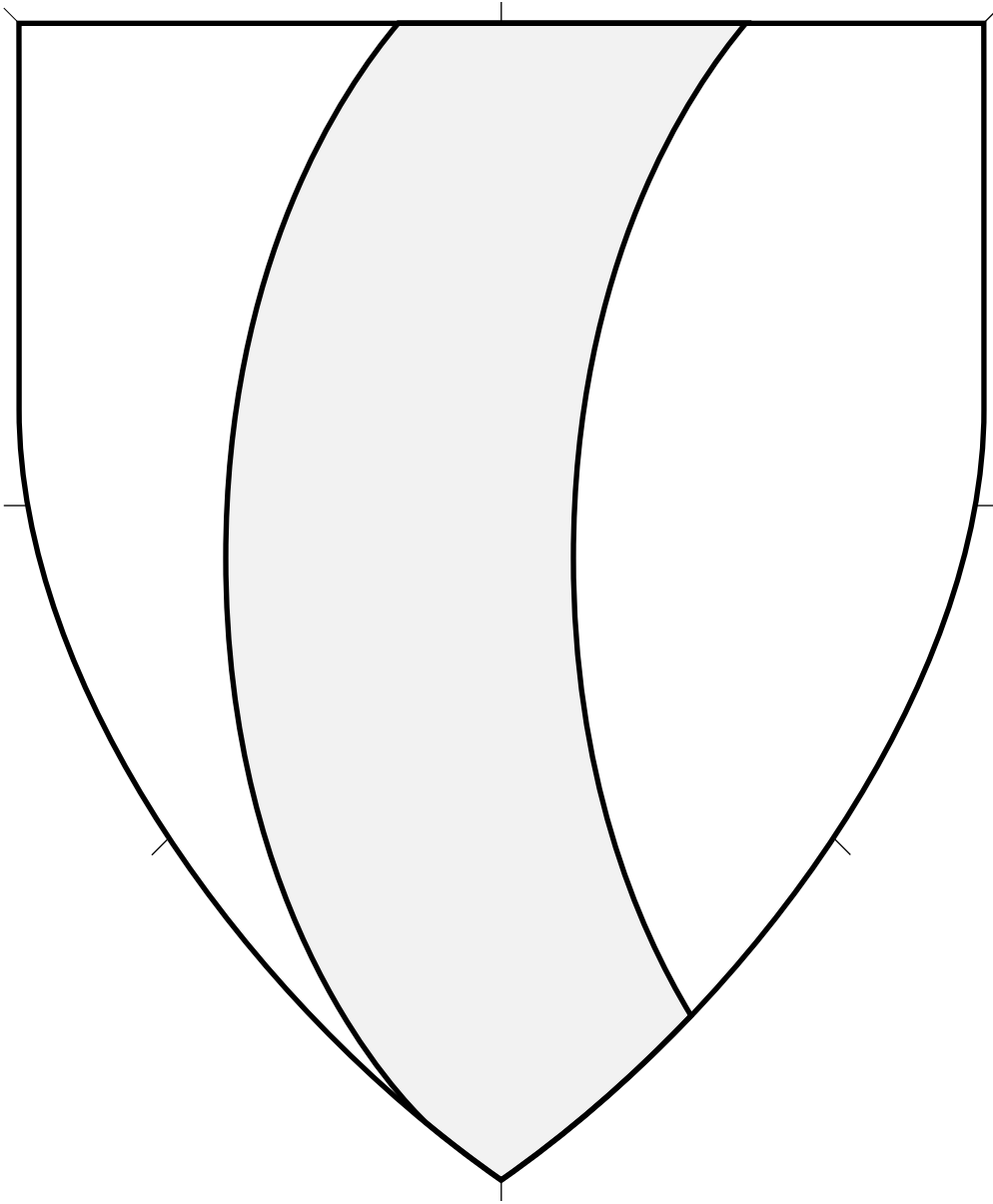

Central ordinary.

Source: BnF MS Allemand 304. Artist unknown. (Page 762.)

Pale Embowed • 4.479

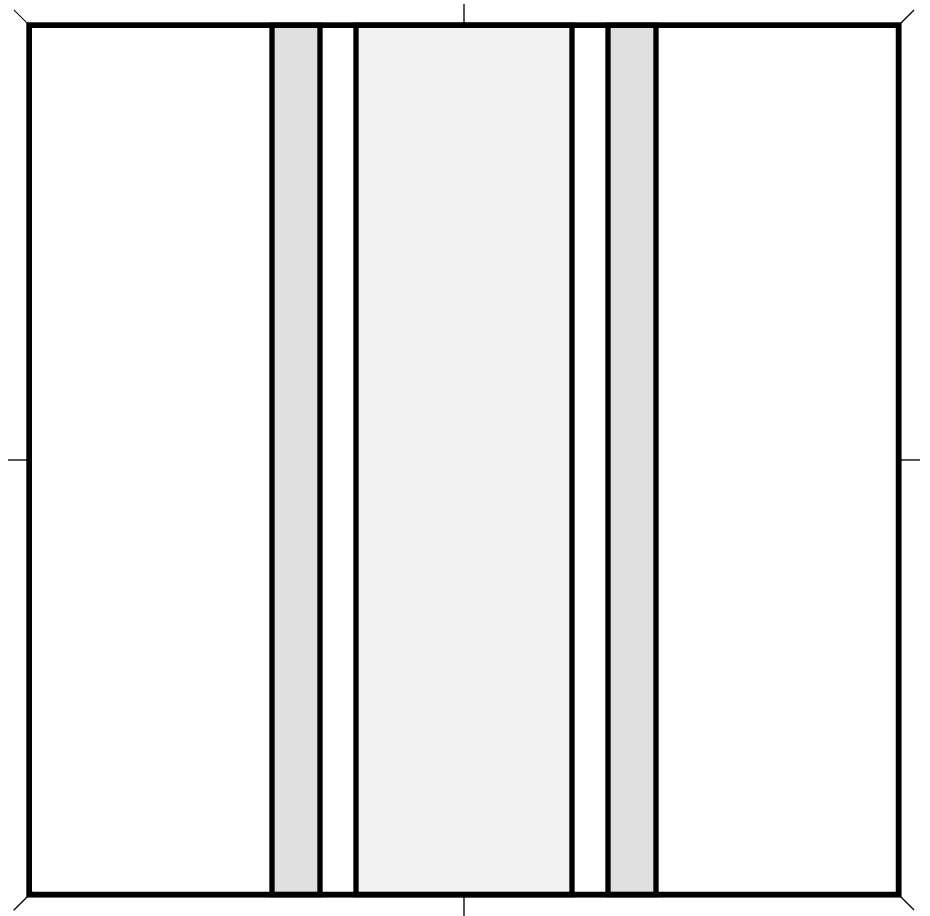
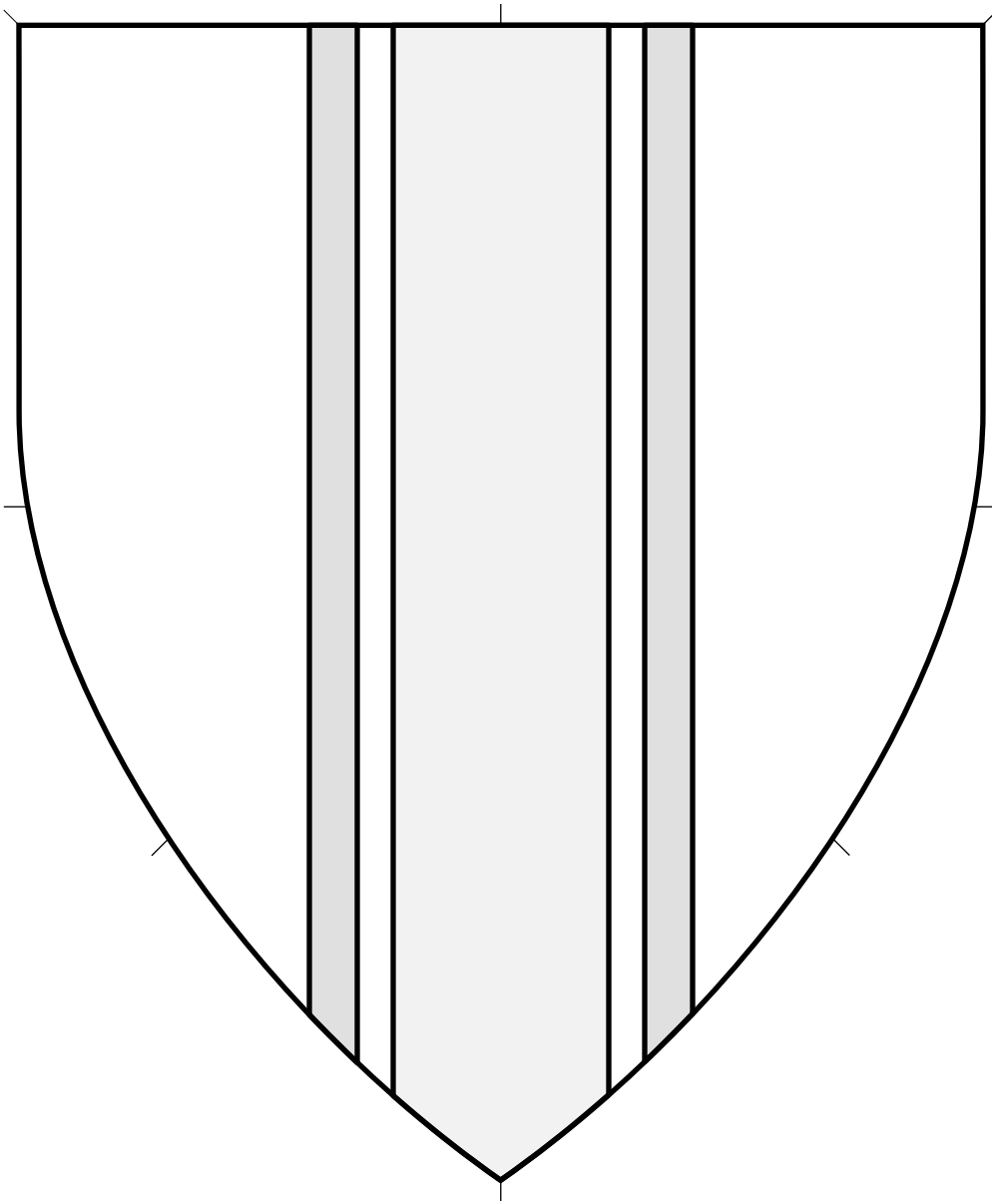

Central ordinary cotised.

Pale Endorsed 4.480

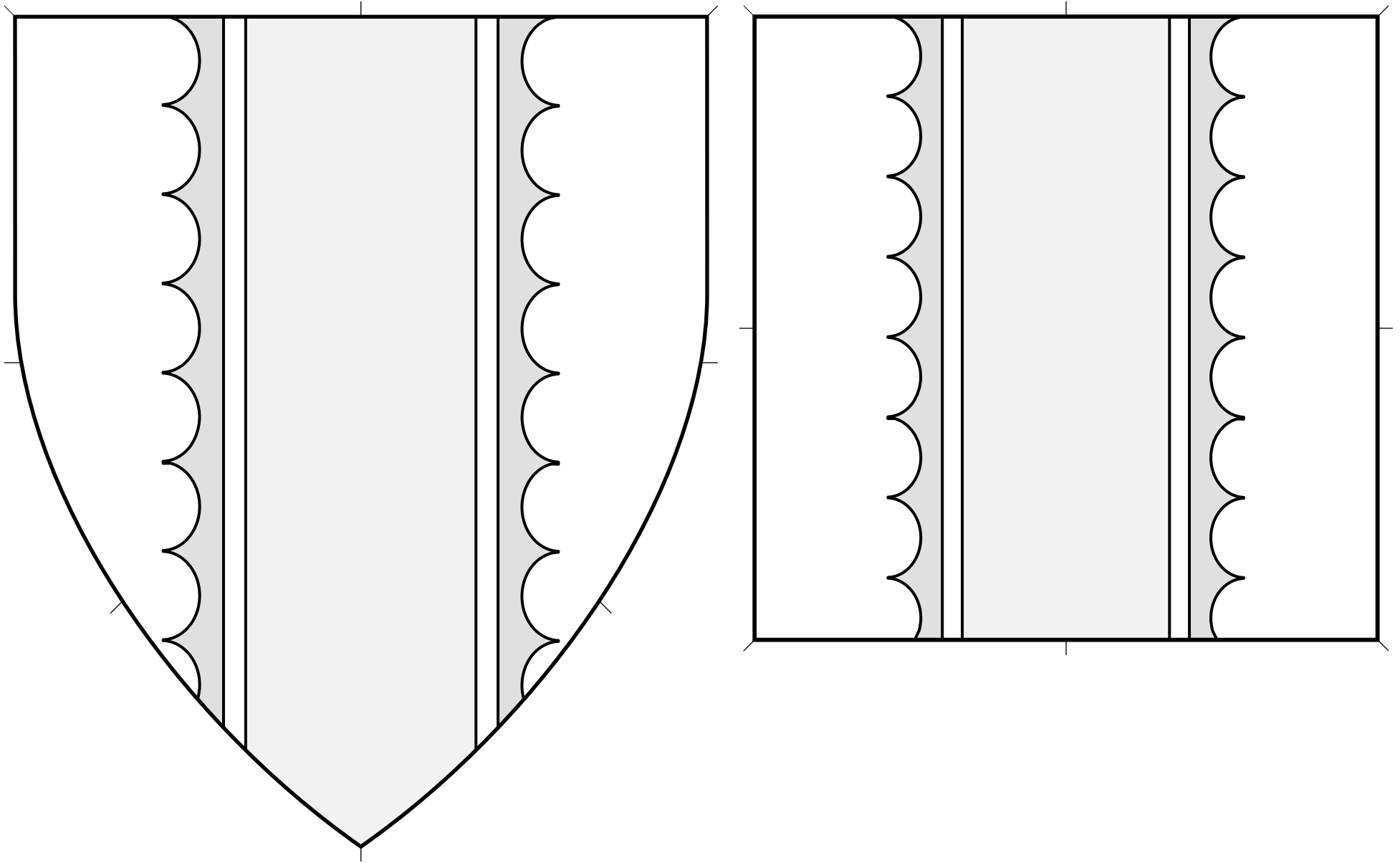

Central ordinary.

Source: Viking Answer Lady SVG Images For Heraldry. Artist: Gunnvör silfrhárr. Adapted by Mathghamhain Ua Ruadháin.

Pale Endorsed Engrailed On The Outer Edge 4.481

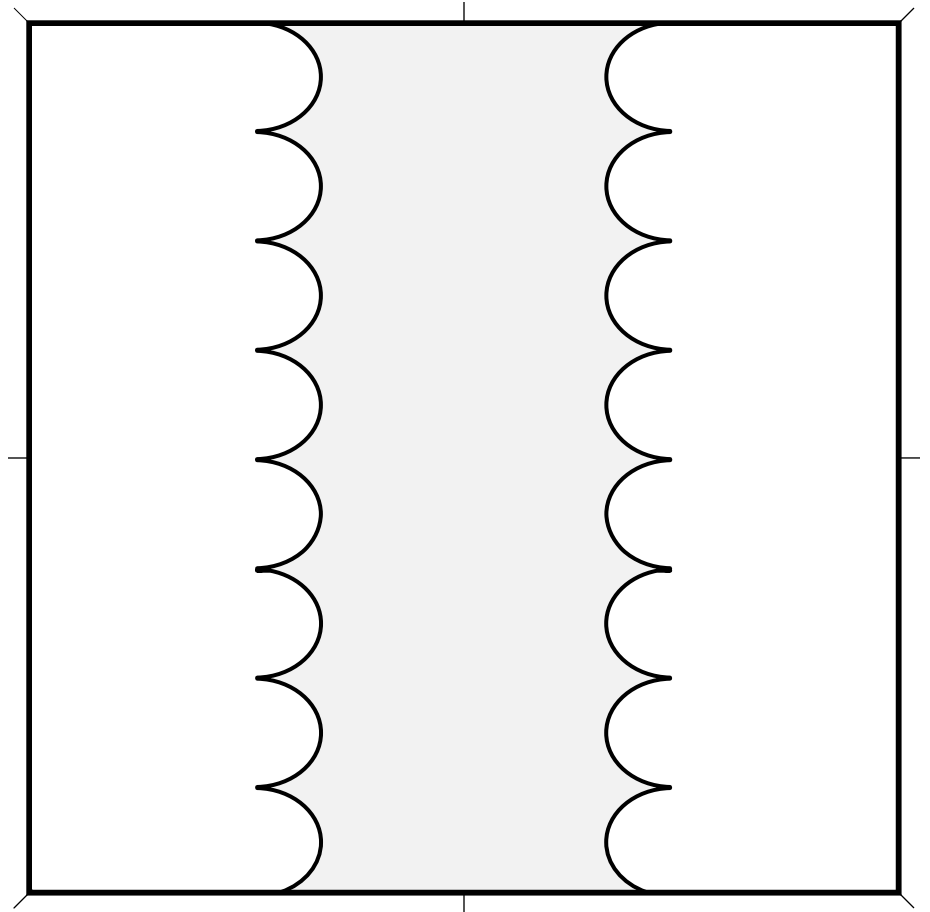
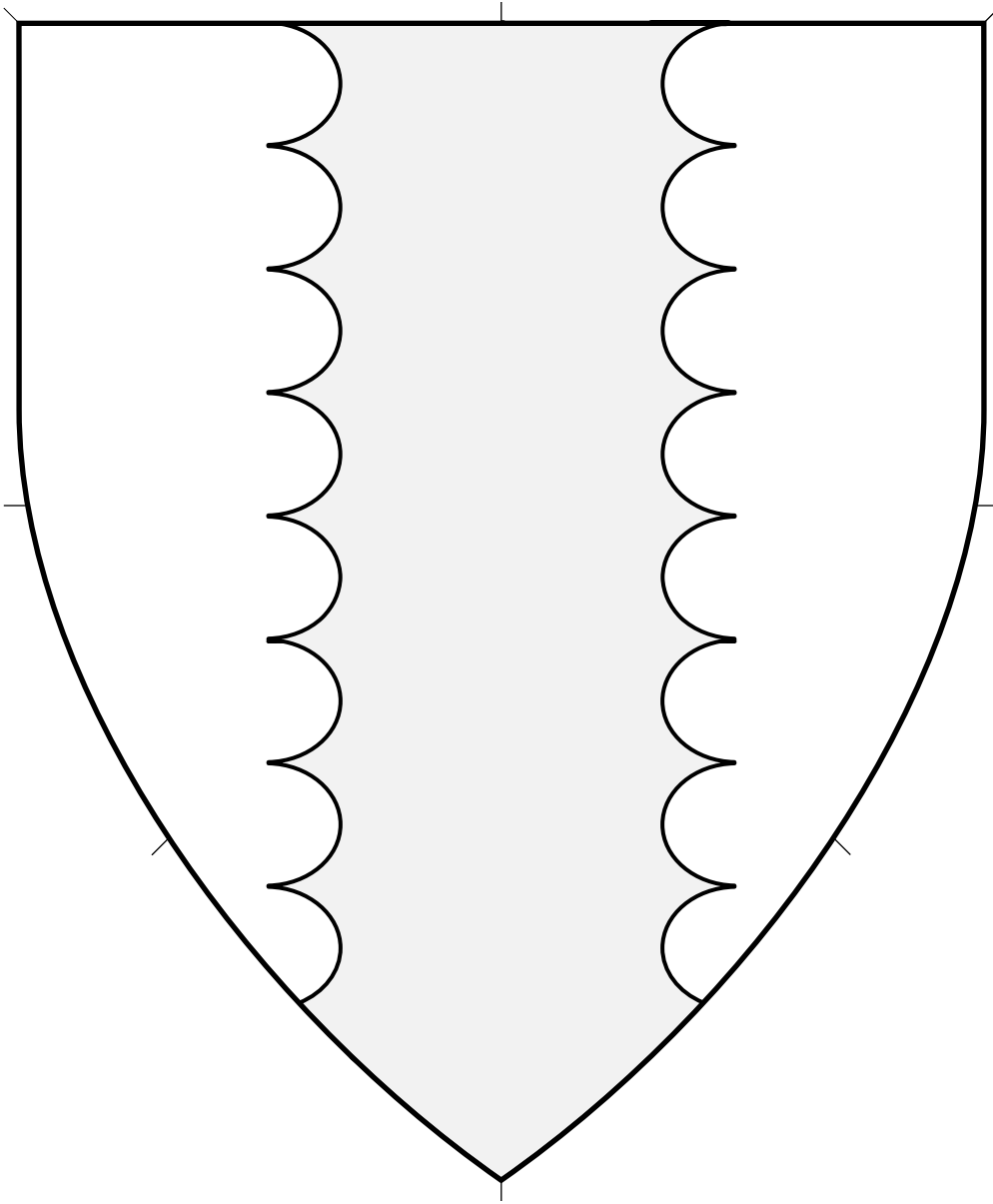

Central ordinary.

Source: Viking Answer Lady SVG Images For Heraldry.
Artist: Gunnvôr silfrhárr.

Pale Engrailed (1) 4.482

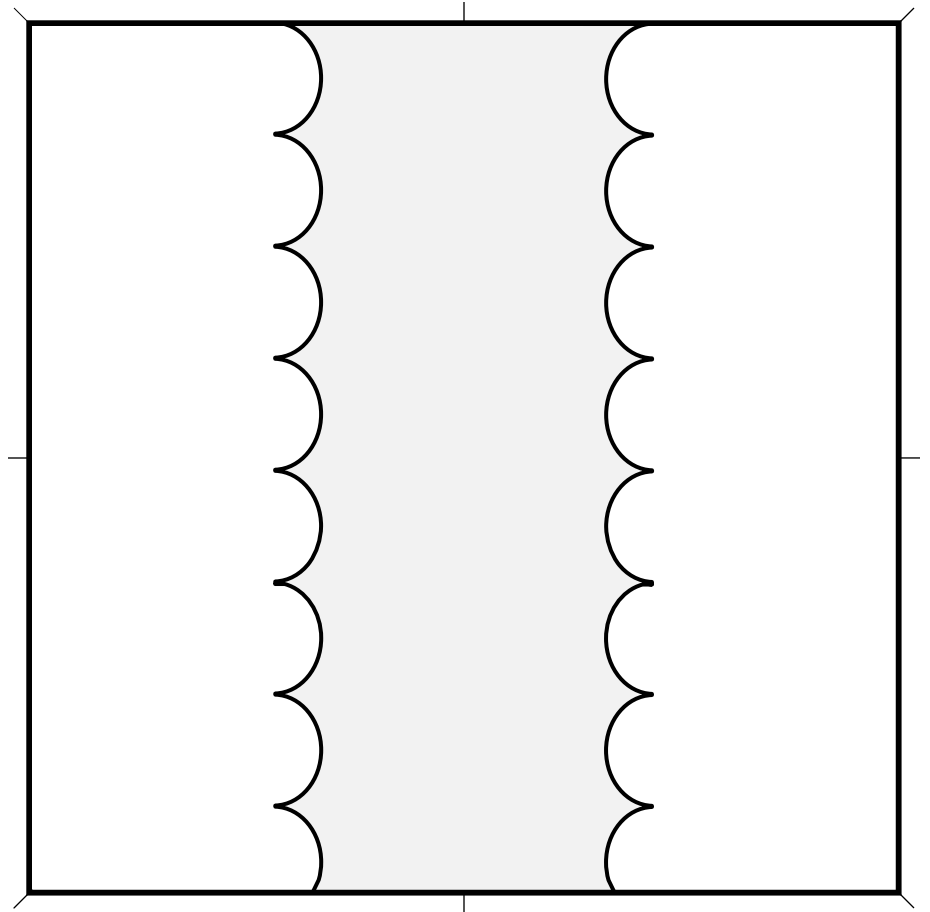
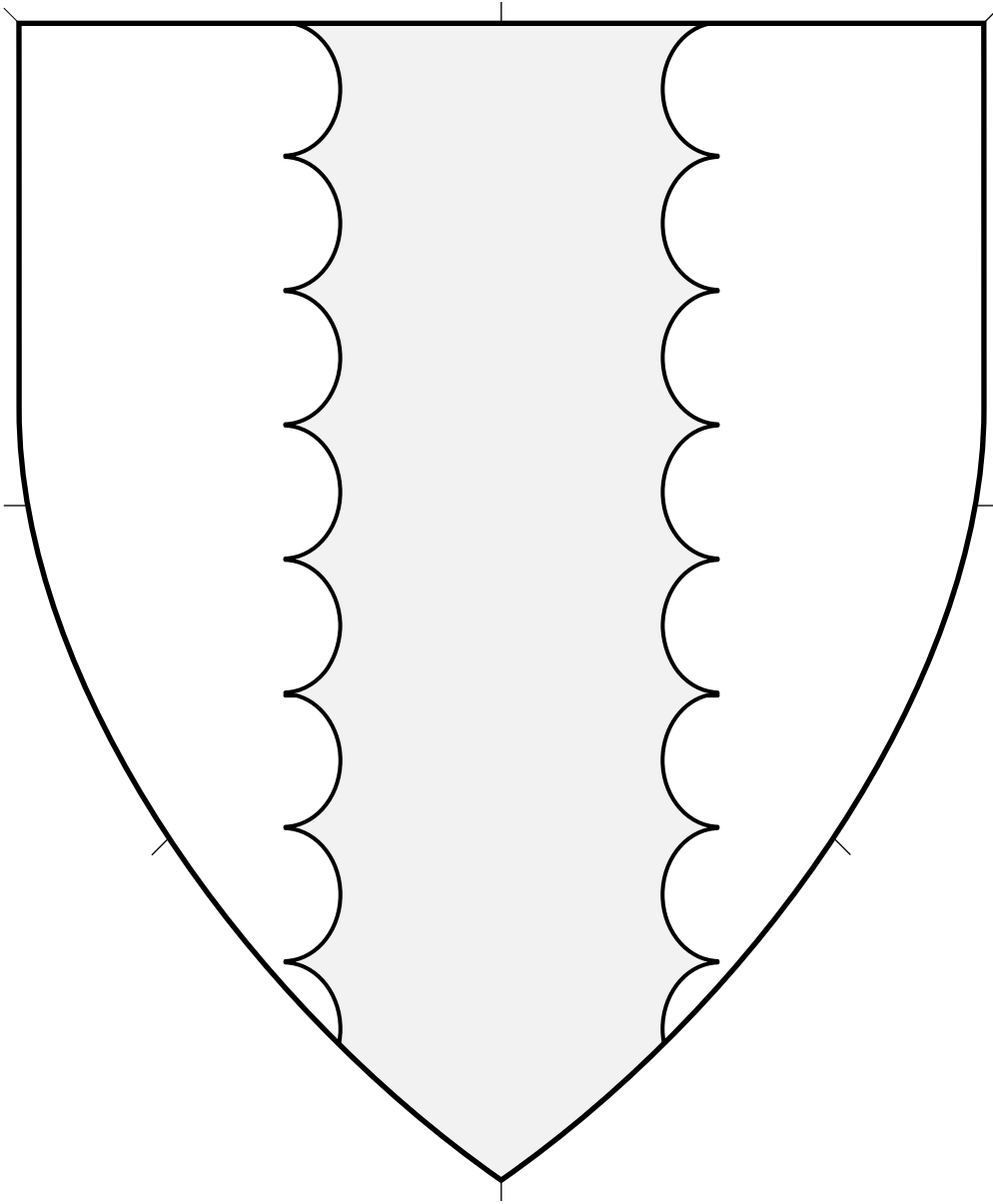

Central ordinary.

Source: Viking Answer Lady SVG Images For Heraldry.
Artist: Gunnvôr silfrhárr. Adapted by Mathghamhain Ua Ruadháin.

Pale Engrailed (2) 4.483

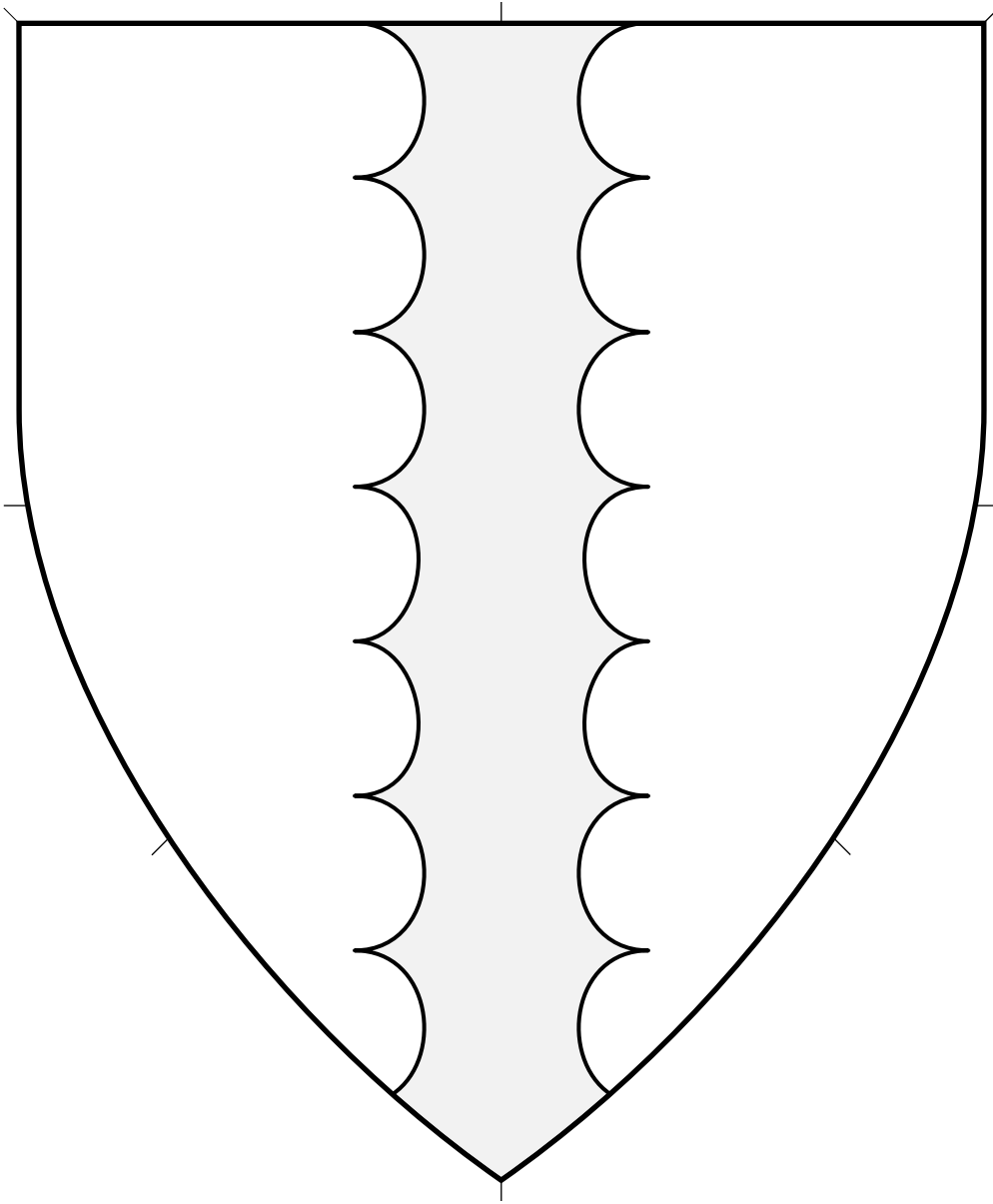

Central ordinary.

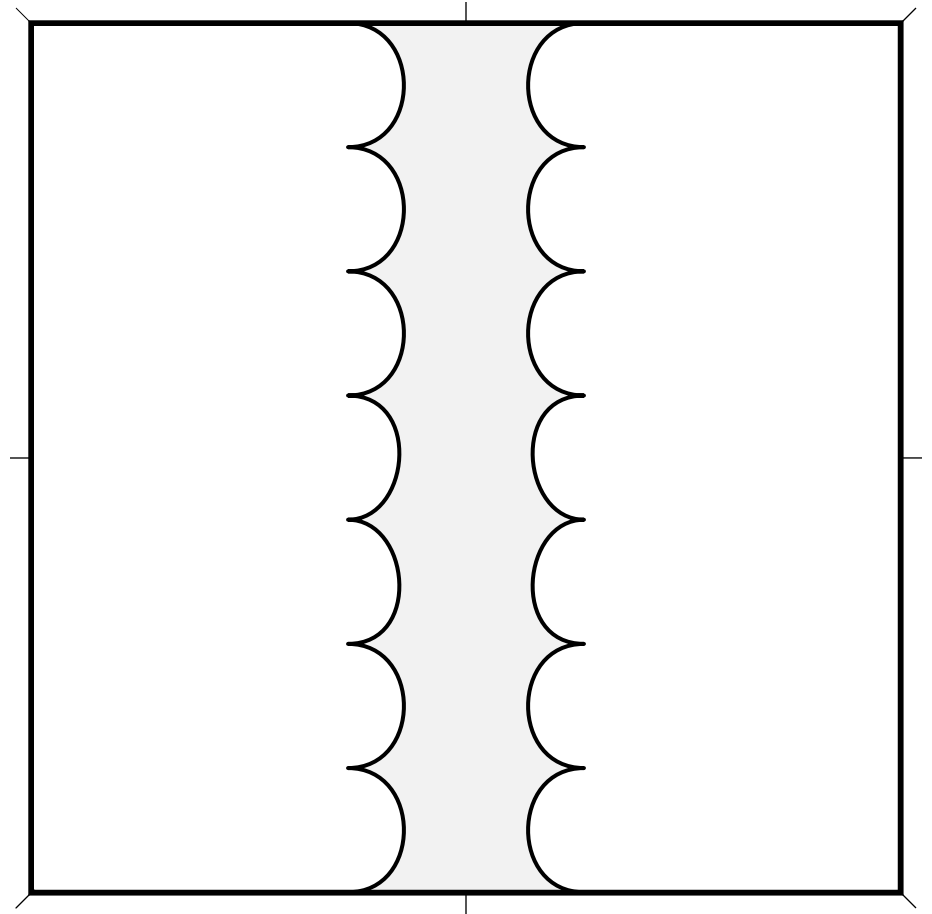

Pale Engrailed (3) 4.484

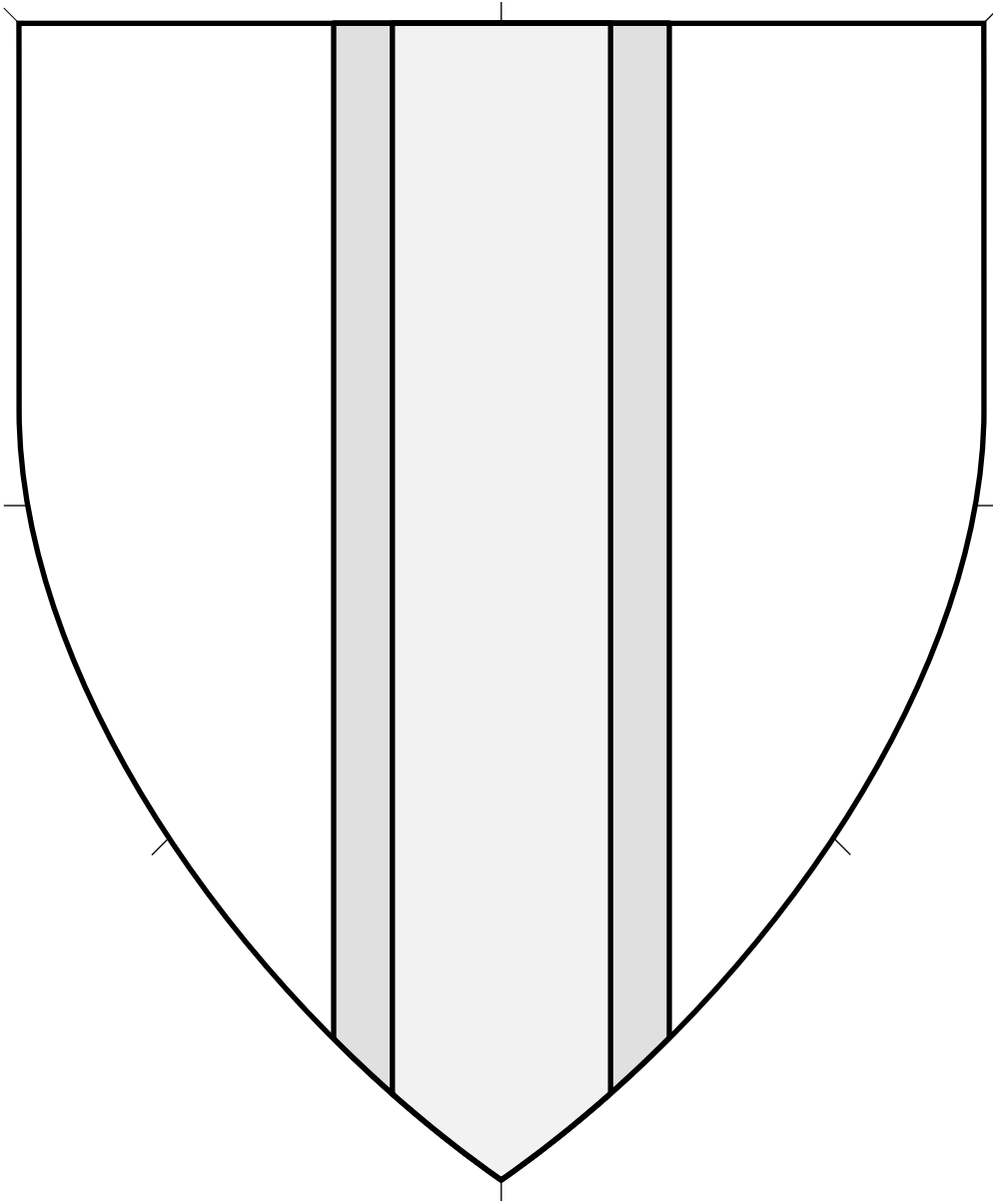

Central ordinary.

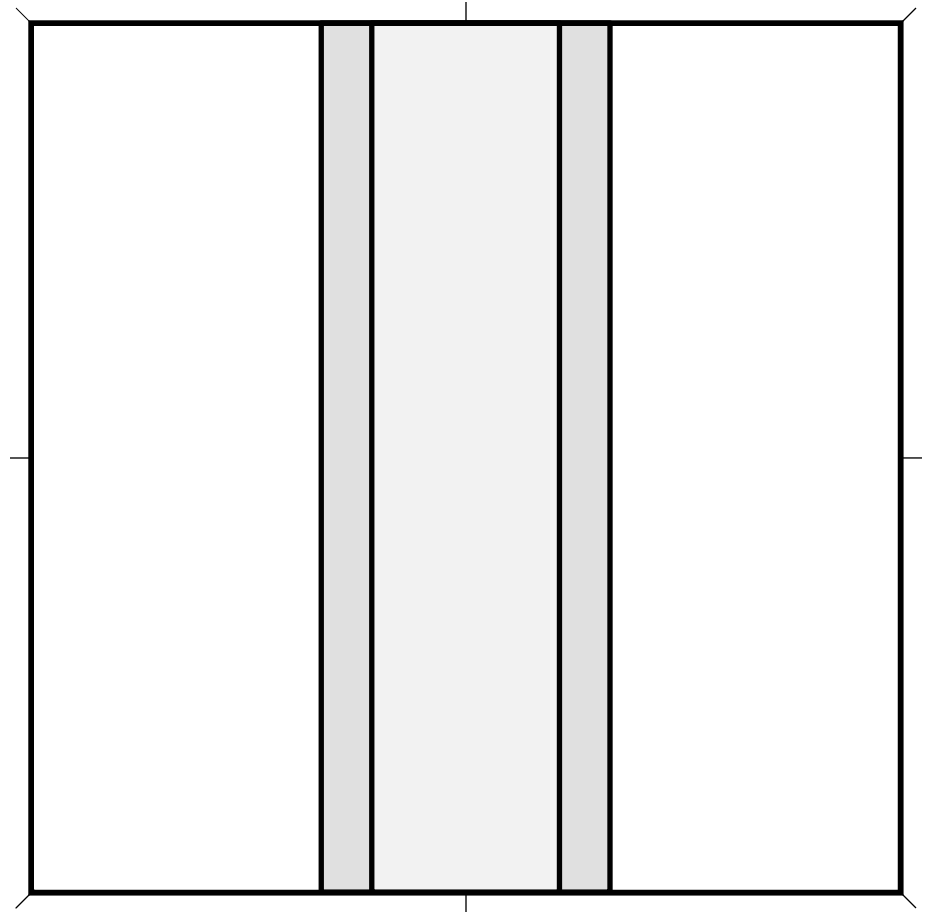

Pale Fimbriated 4.485

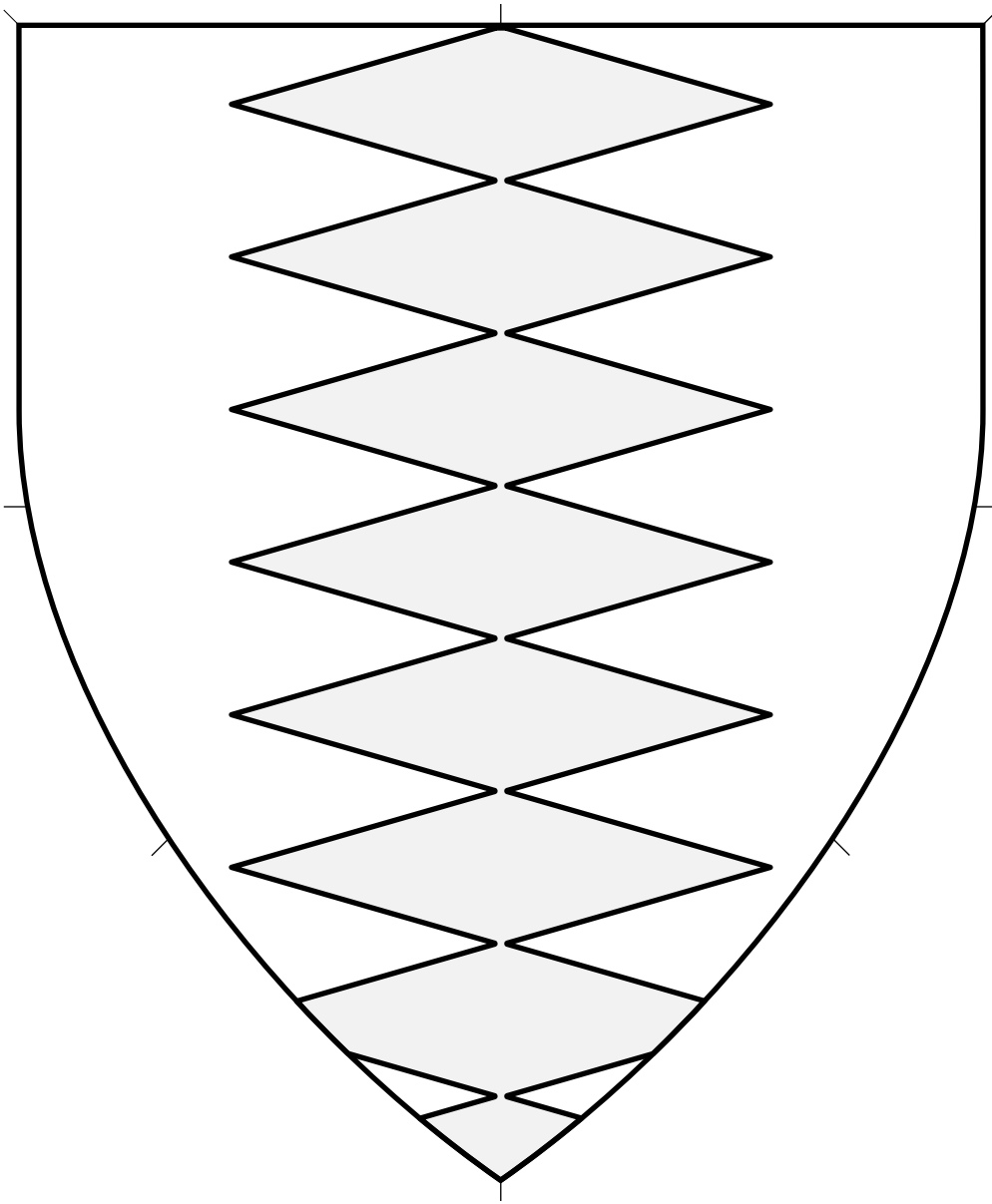

Central ordinary.

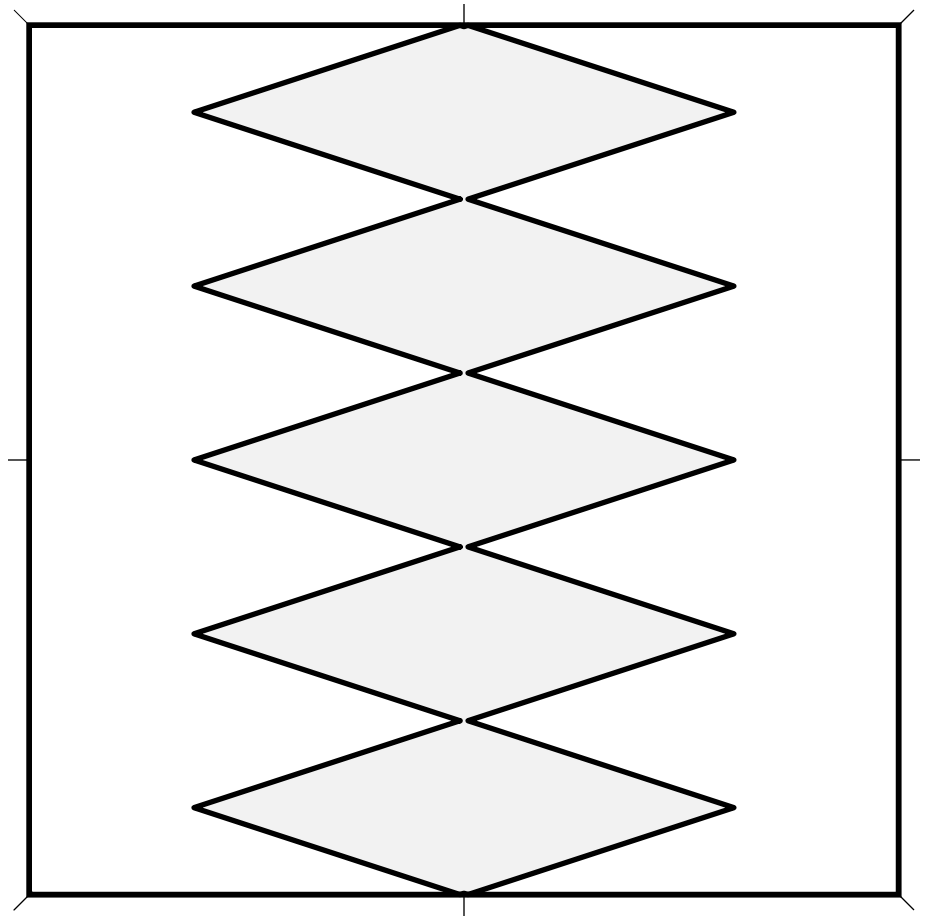

Pale Fusilly (1) • 4.486

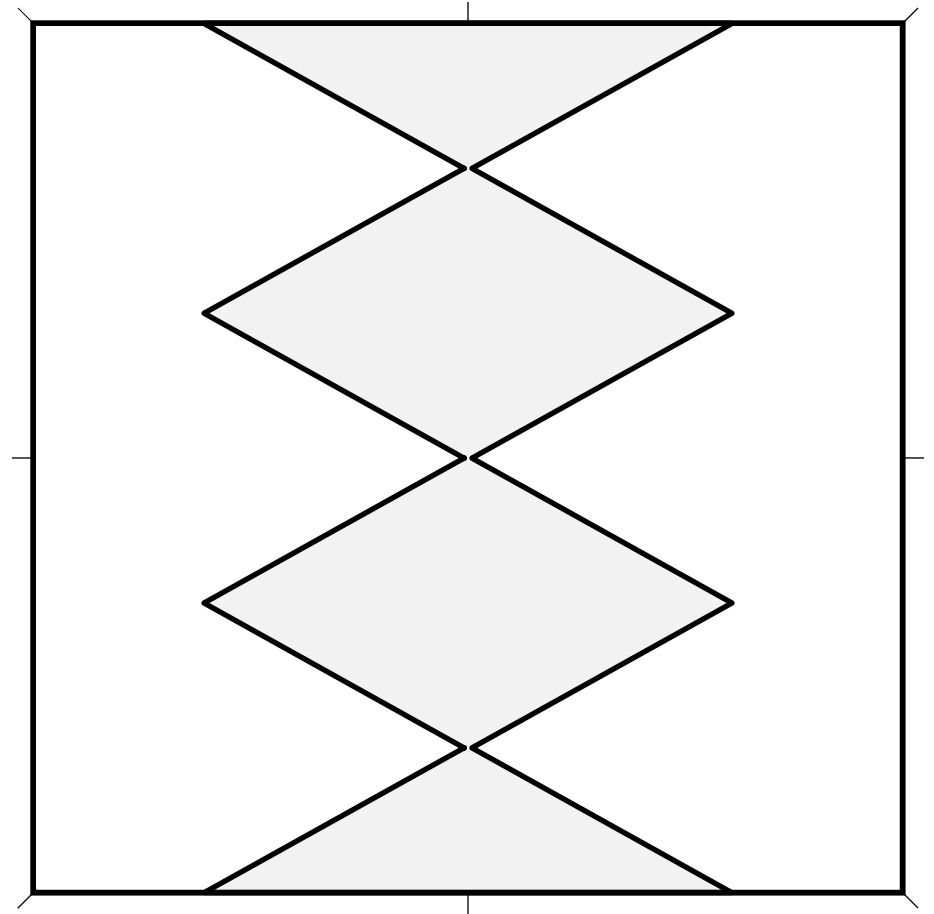
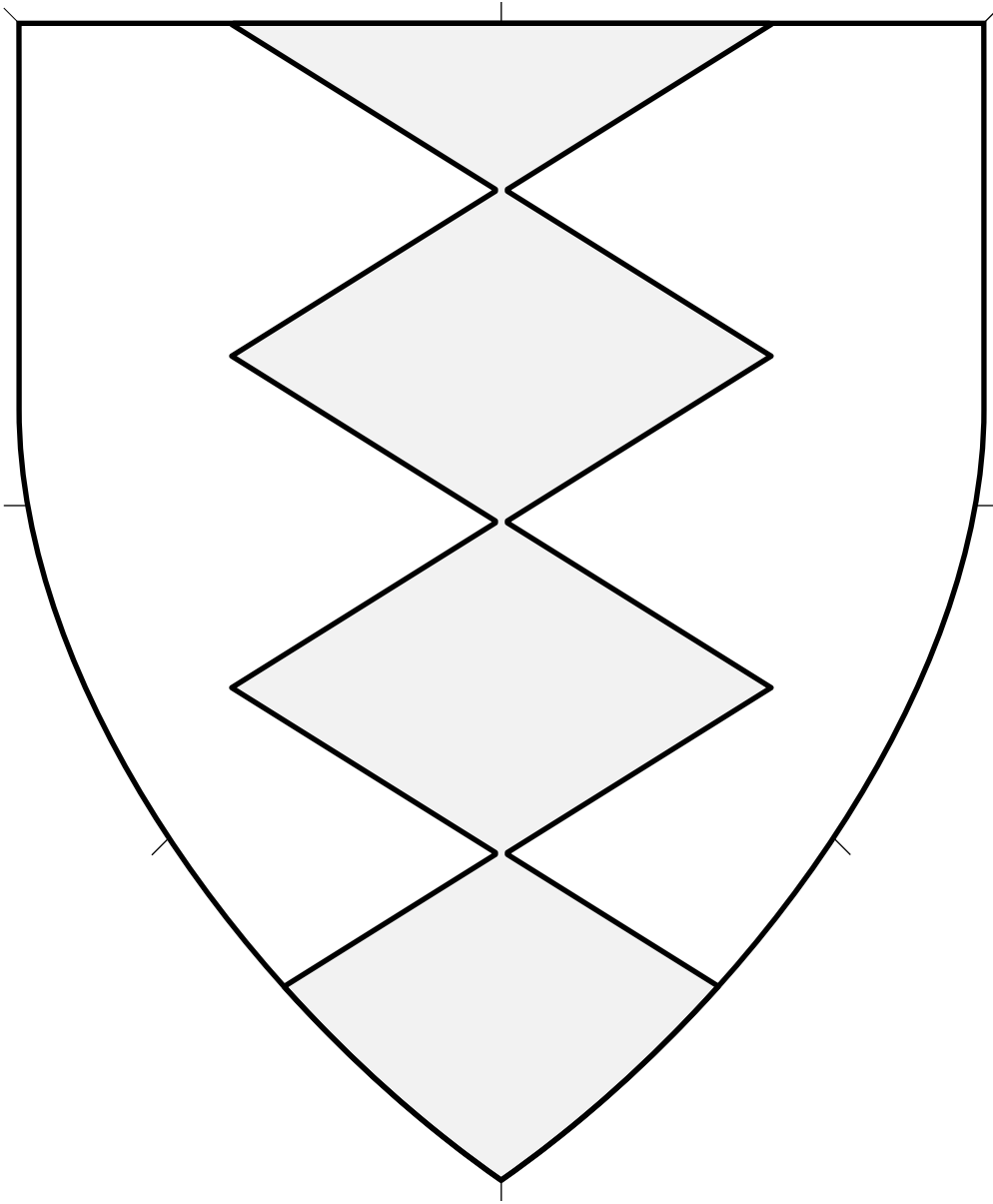

Central ordinary.

Source: Insignia Anglica. Artist unknown. (Page 104.)

Pale Fusilly (2) 4.487

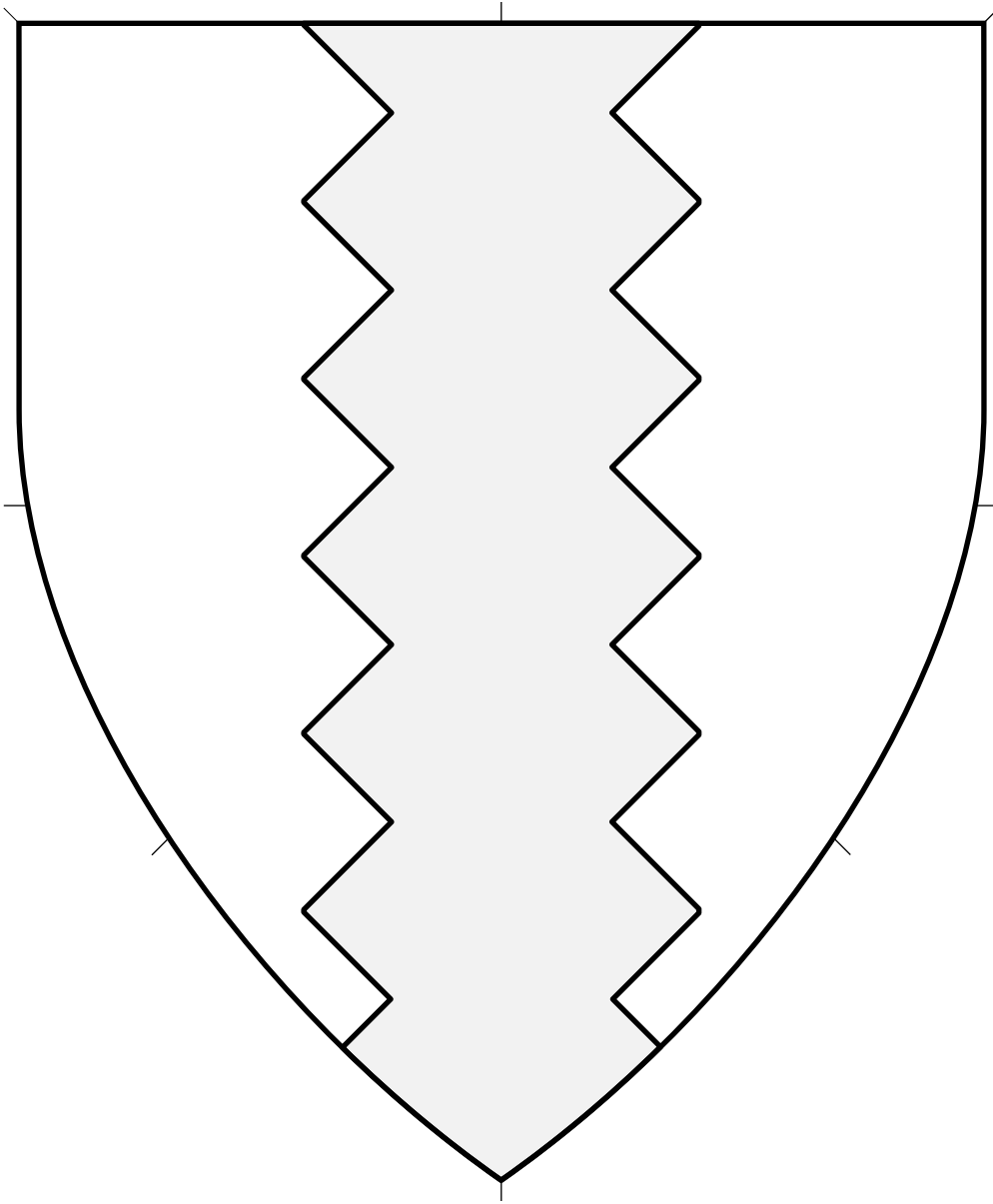

Central ordinary.

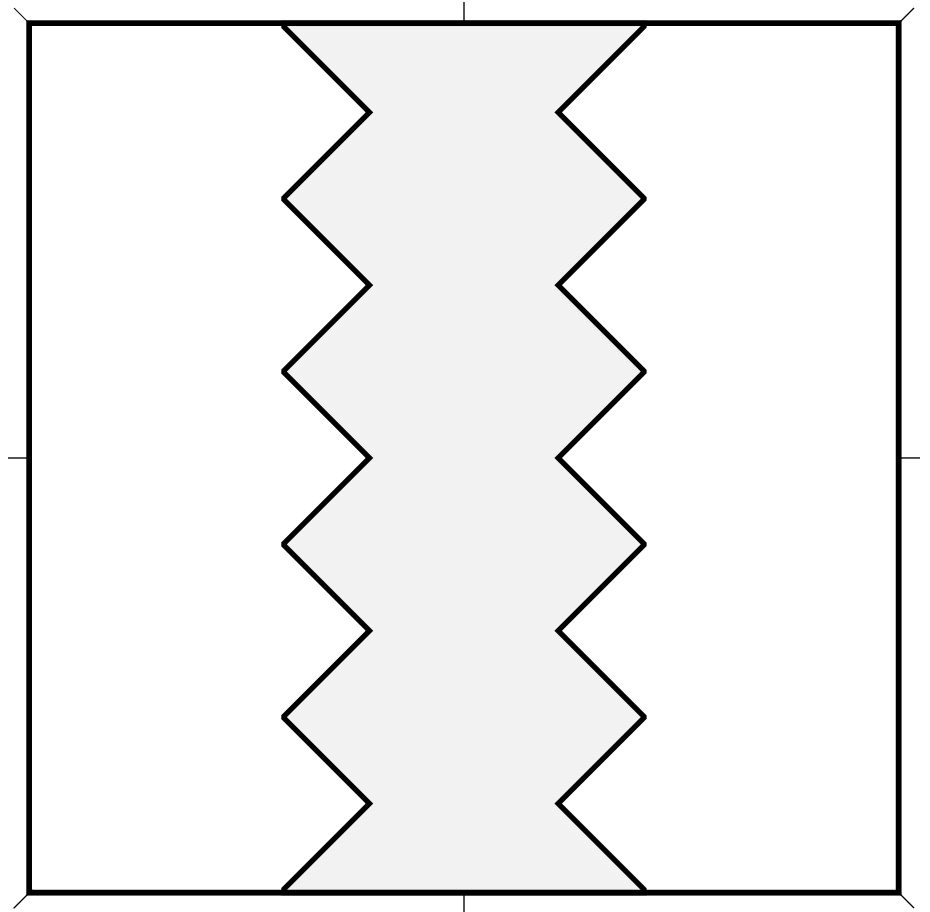

Pale Indented (1) 4.488

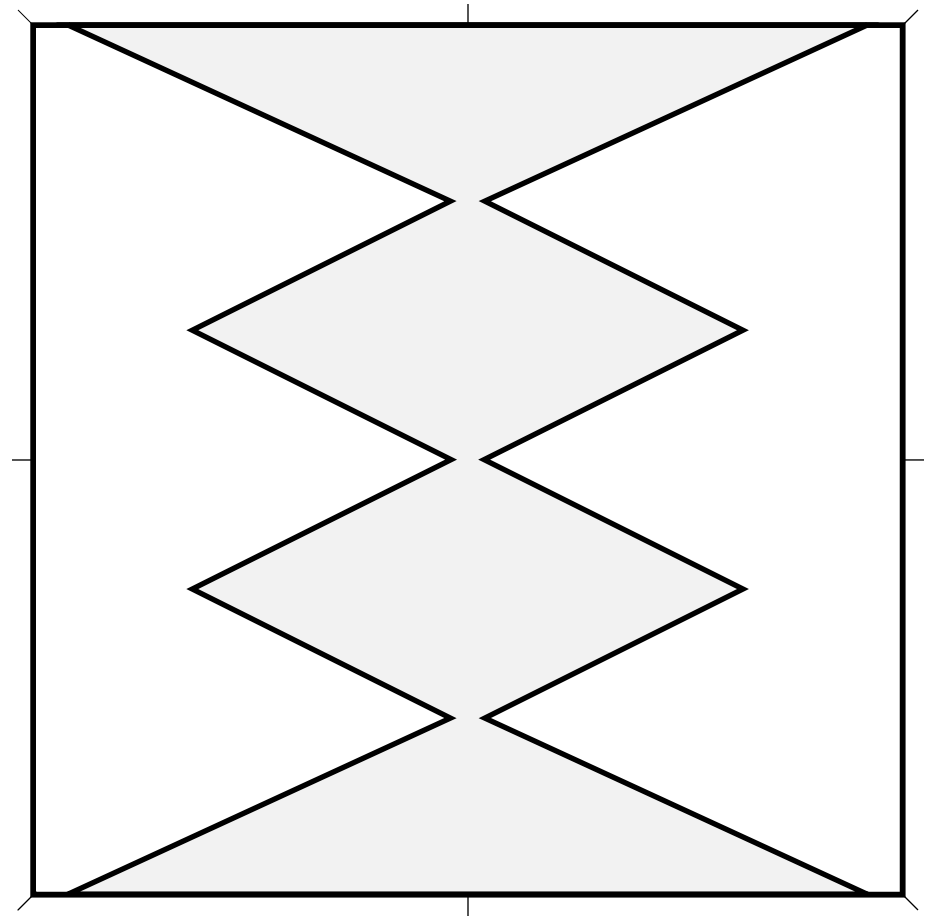
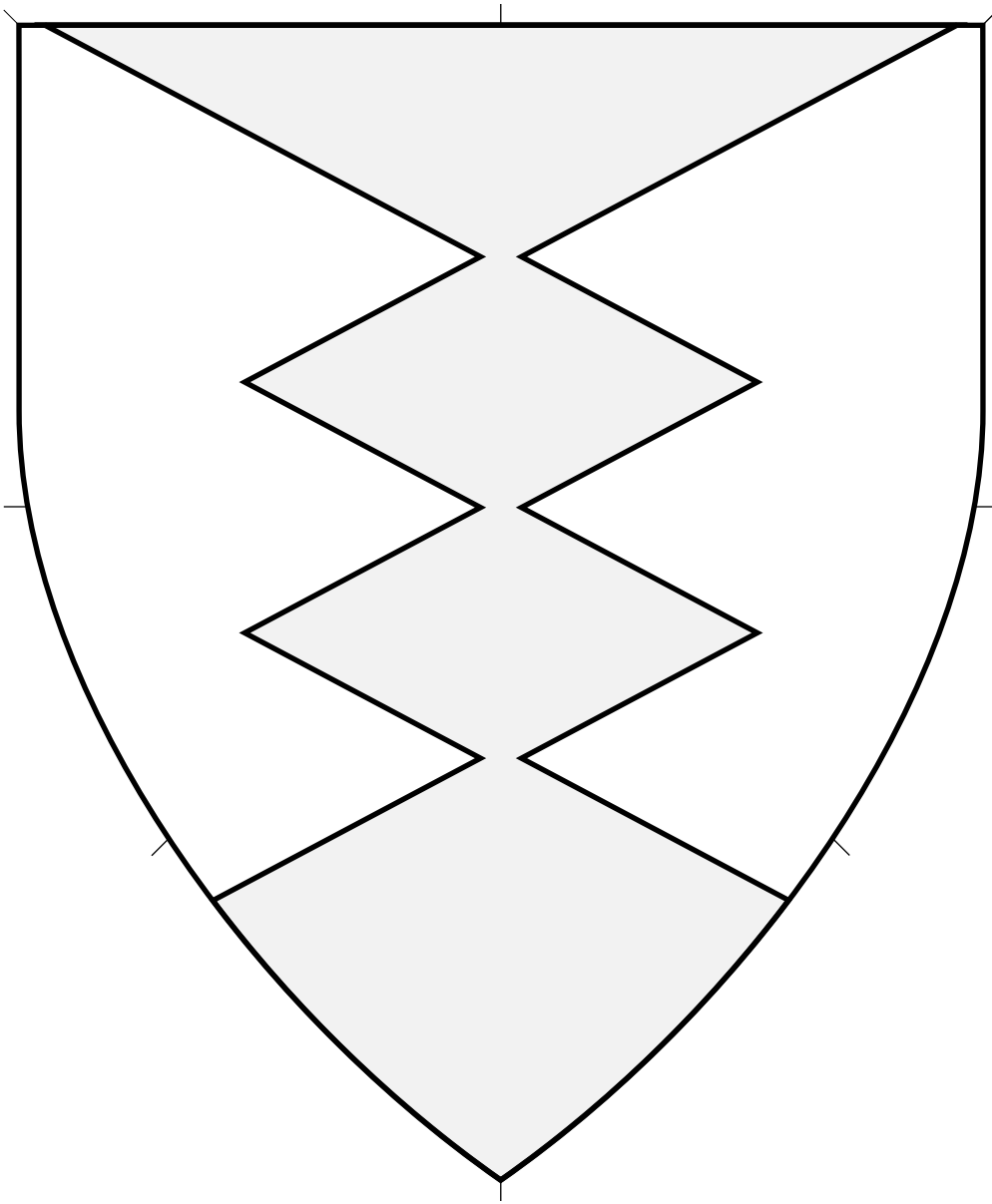

Central ordinary.

Source: Two Tudor Books of Arms. Artist: Robert Cooke. (From page 42.)

Pale Indented (2) • 4.489

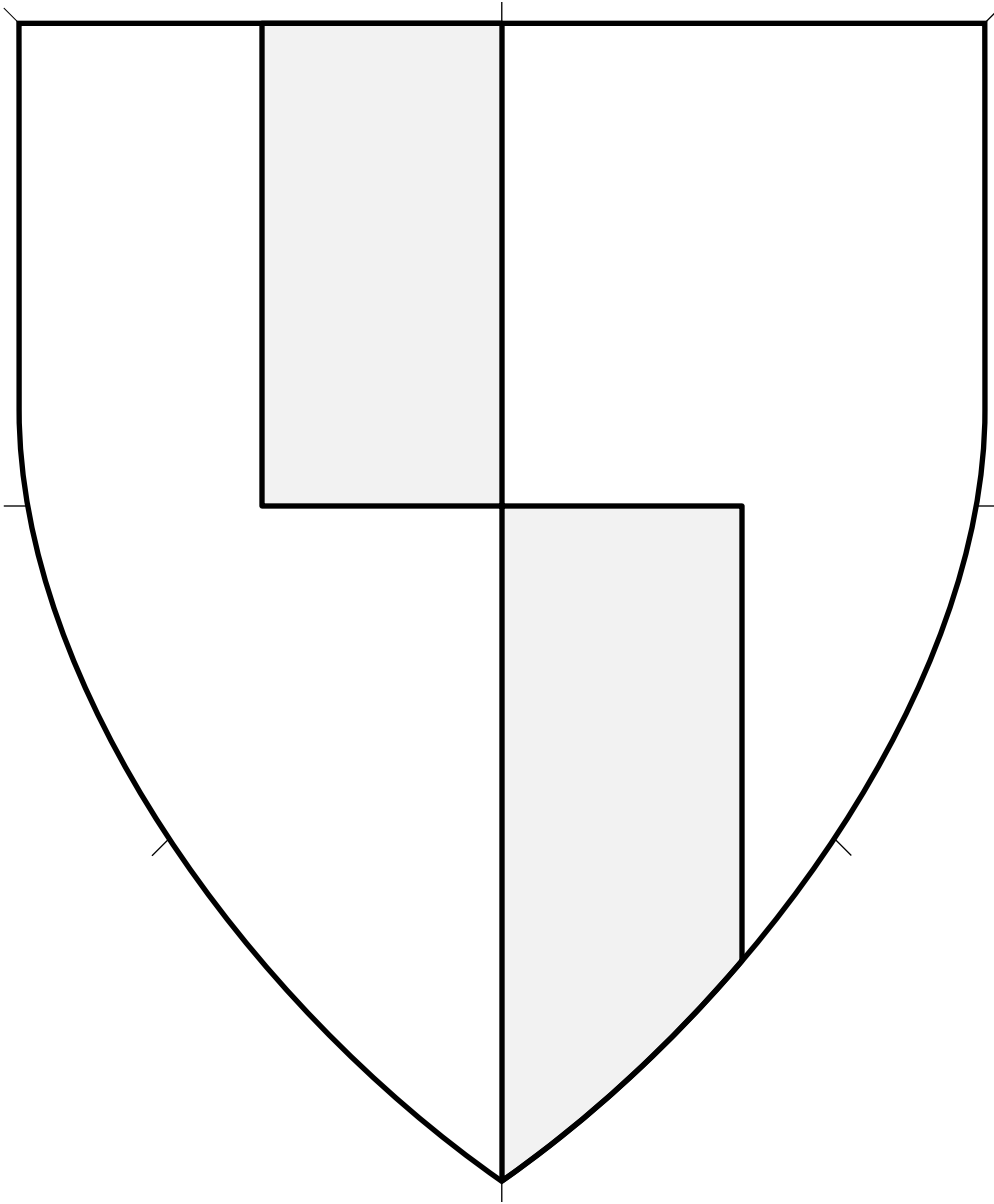

Central ordinary.

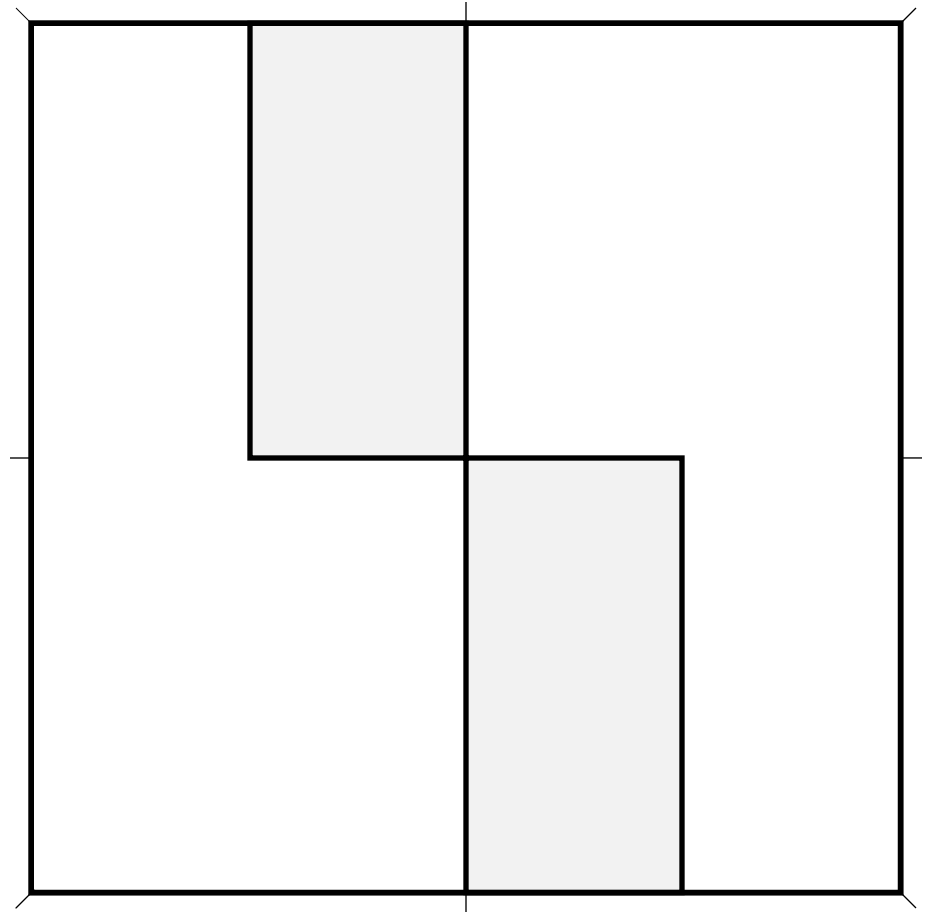

Pale Offset 4.490

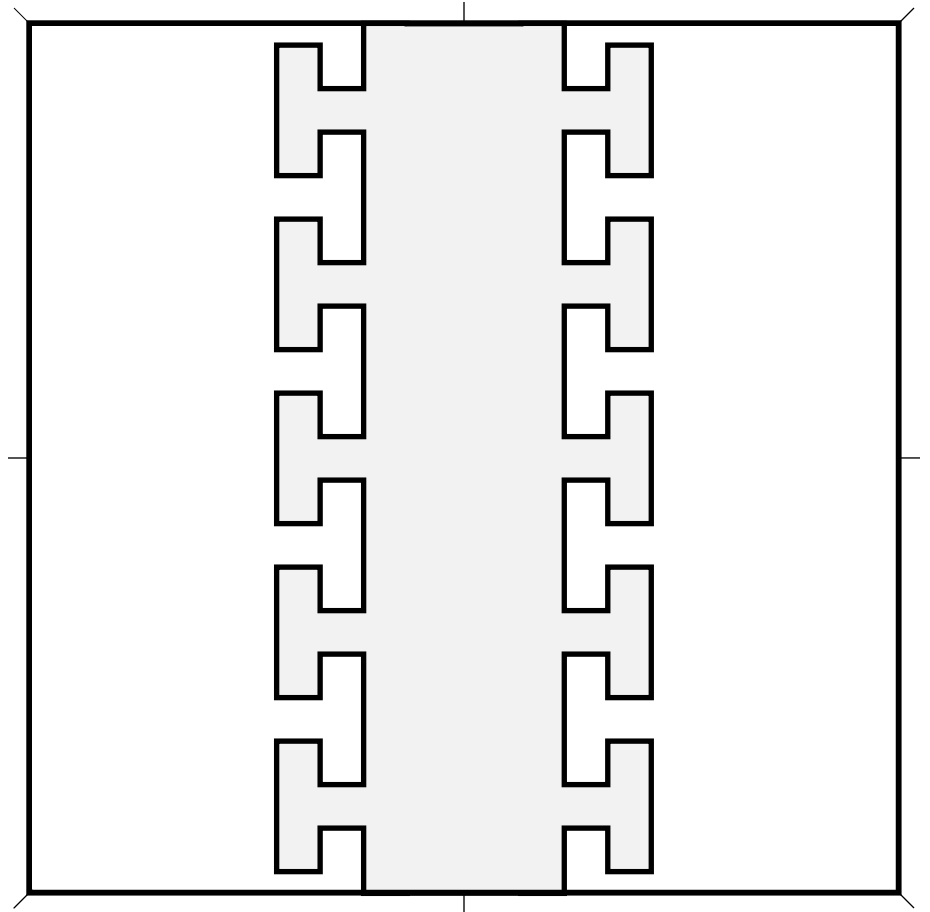
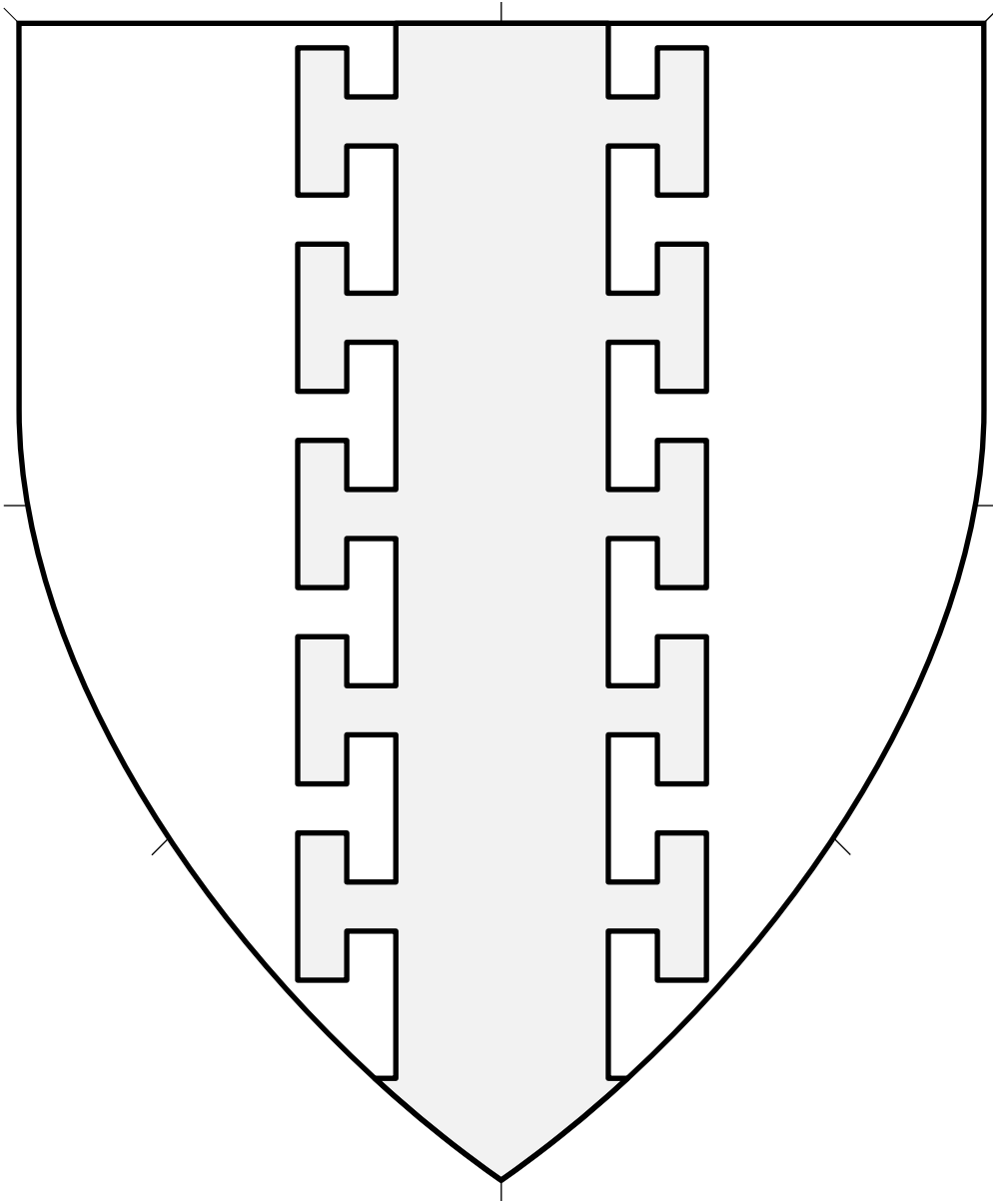

Central ordinary.

Pale Potenty 4.491

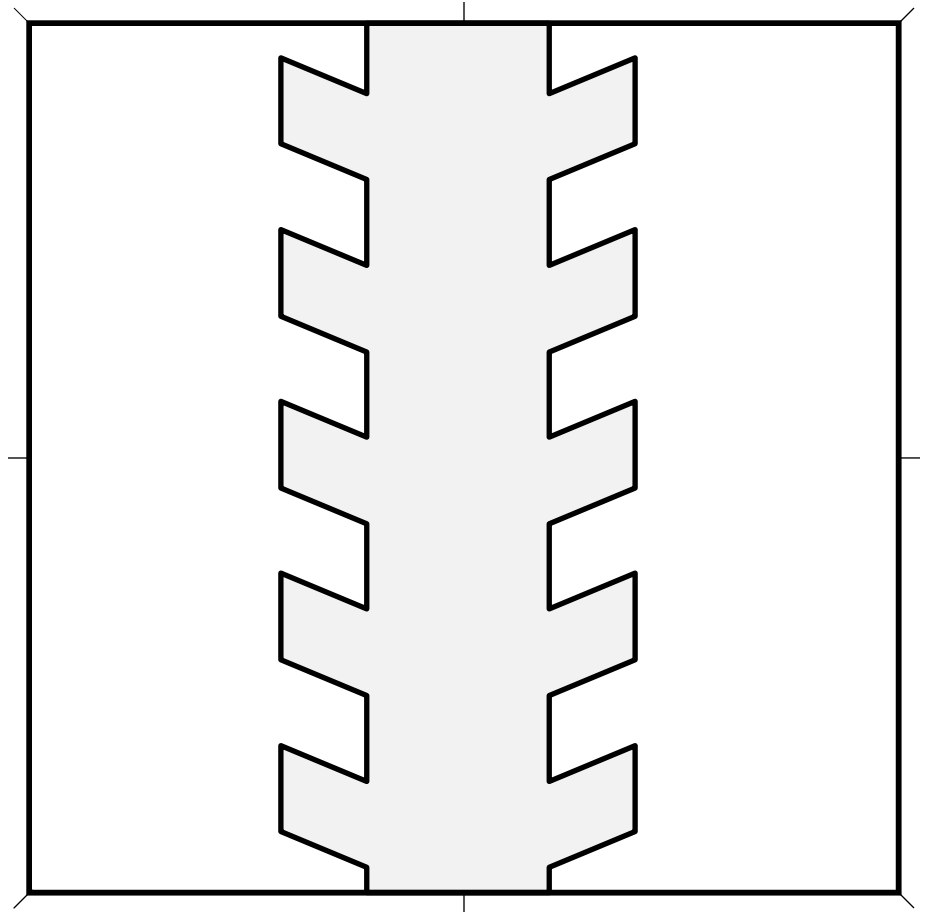
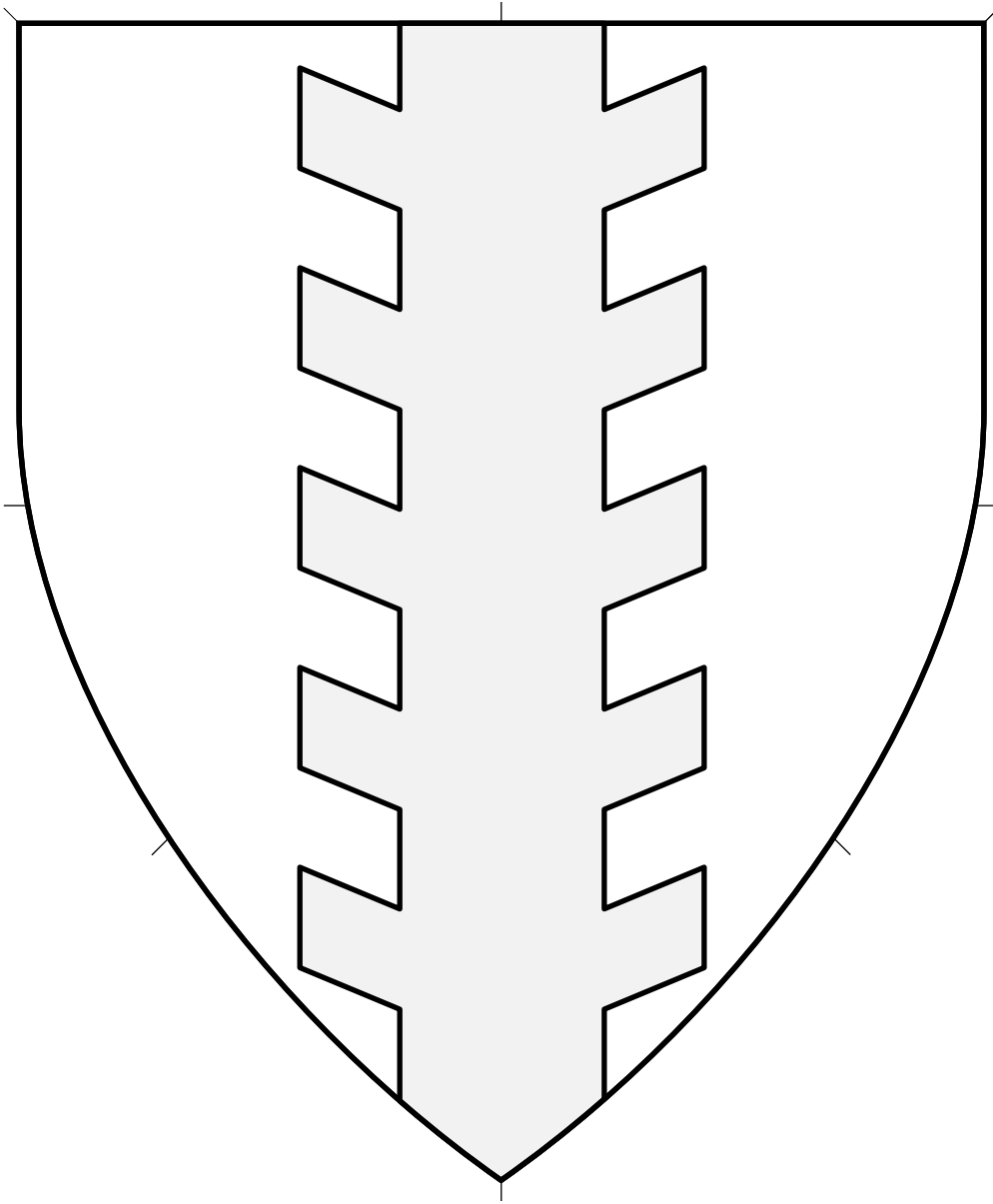

Central ordinary.

Pale Raguly (1) 4.492

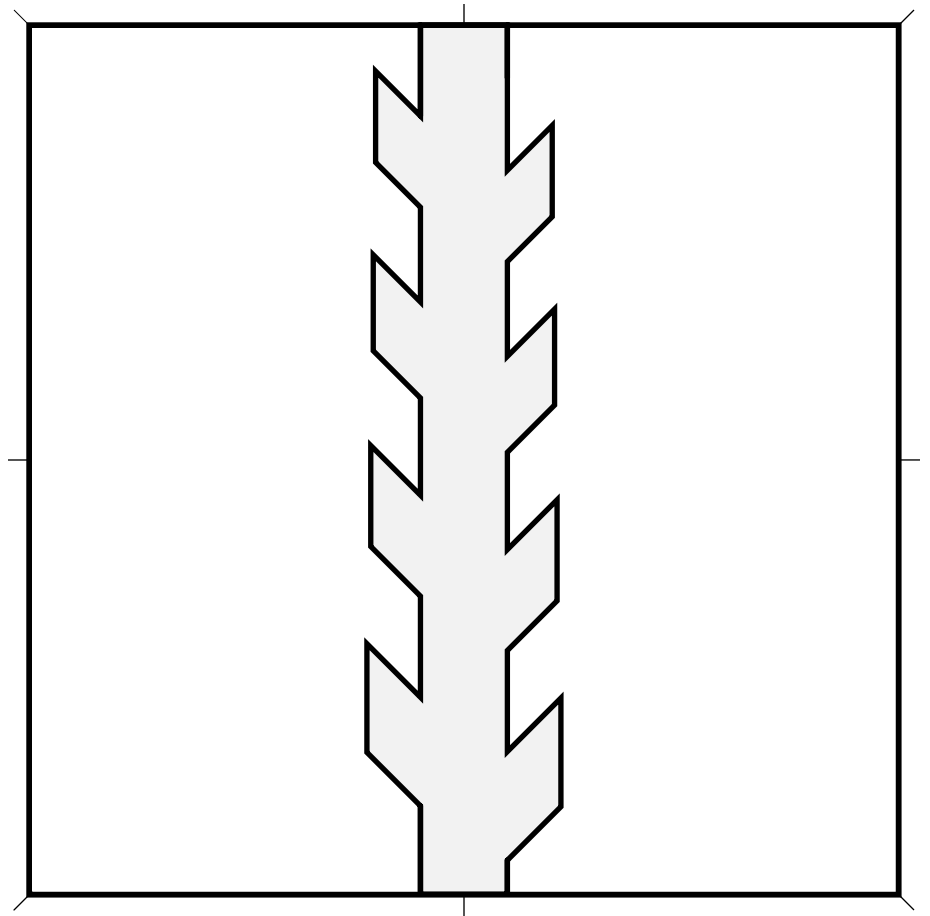
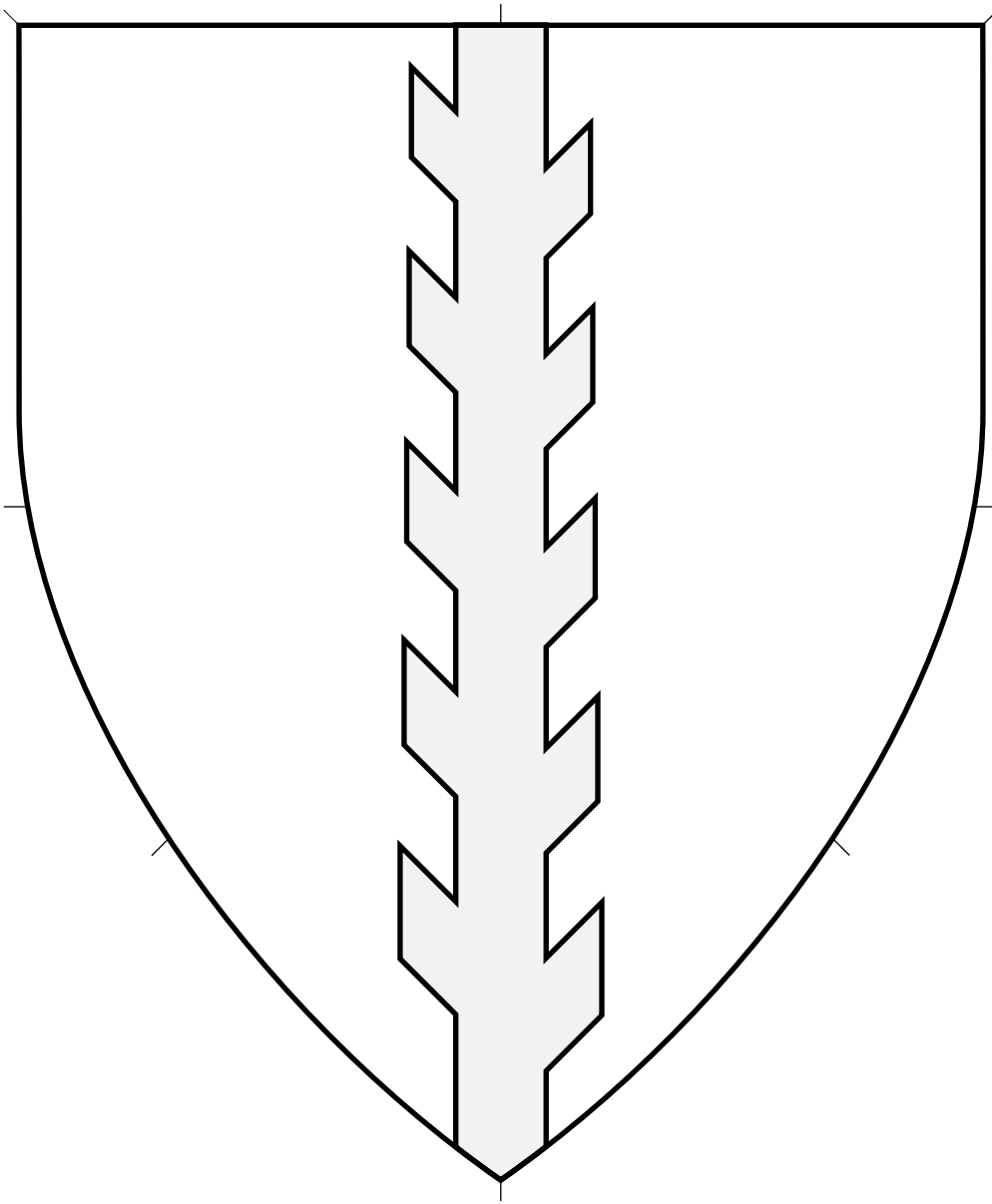

Central ordinary.

Pale Raguly (2) 4.493

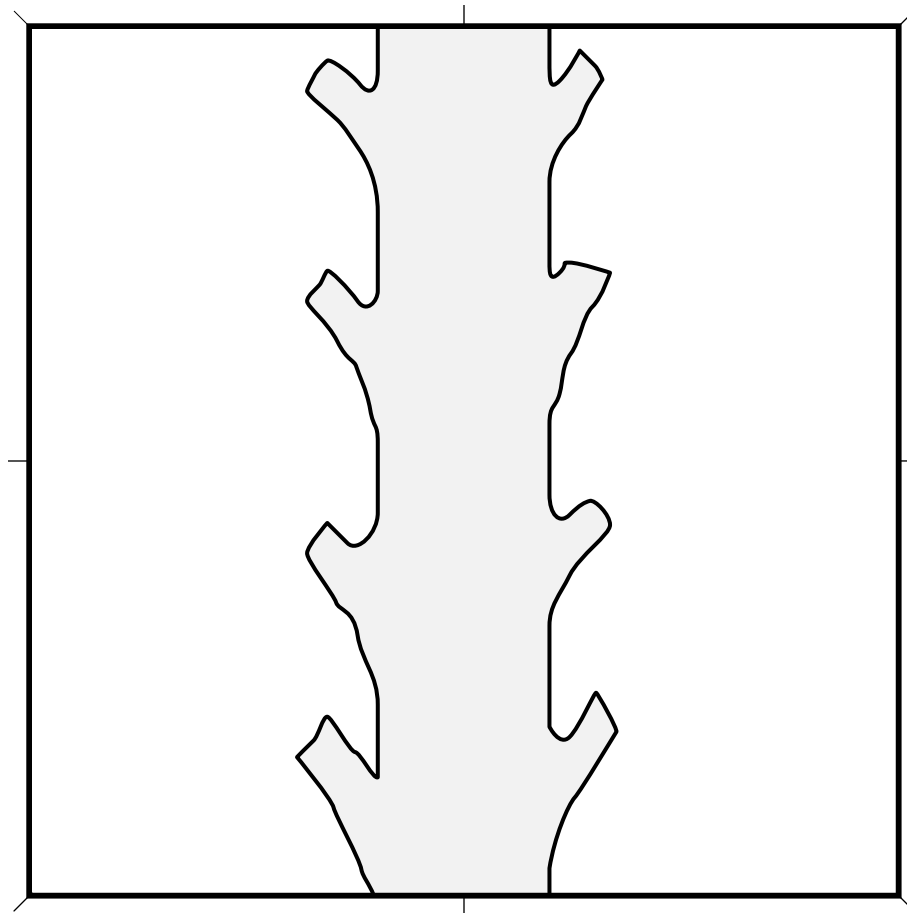
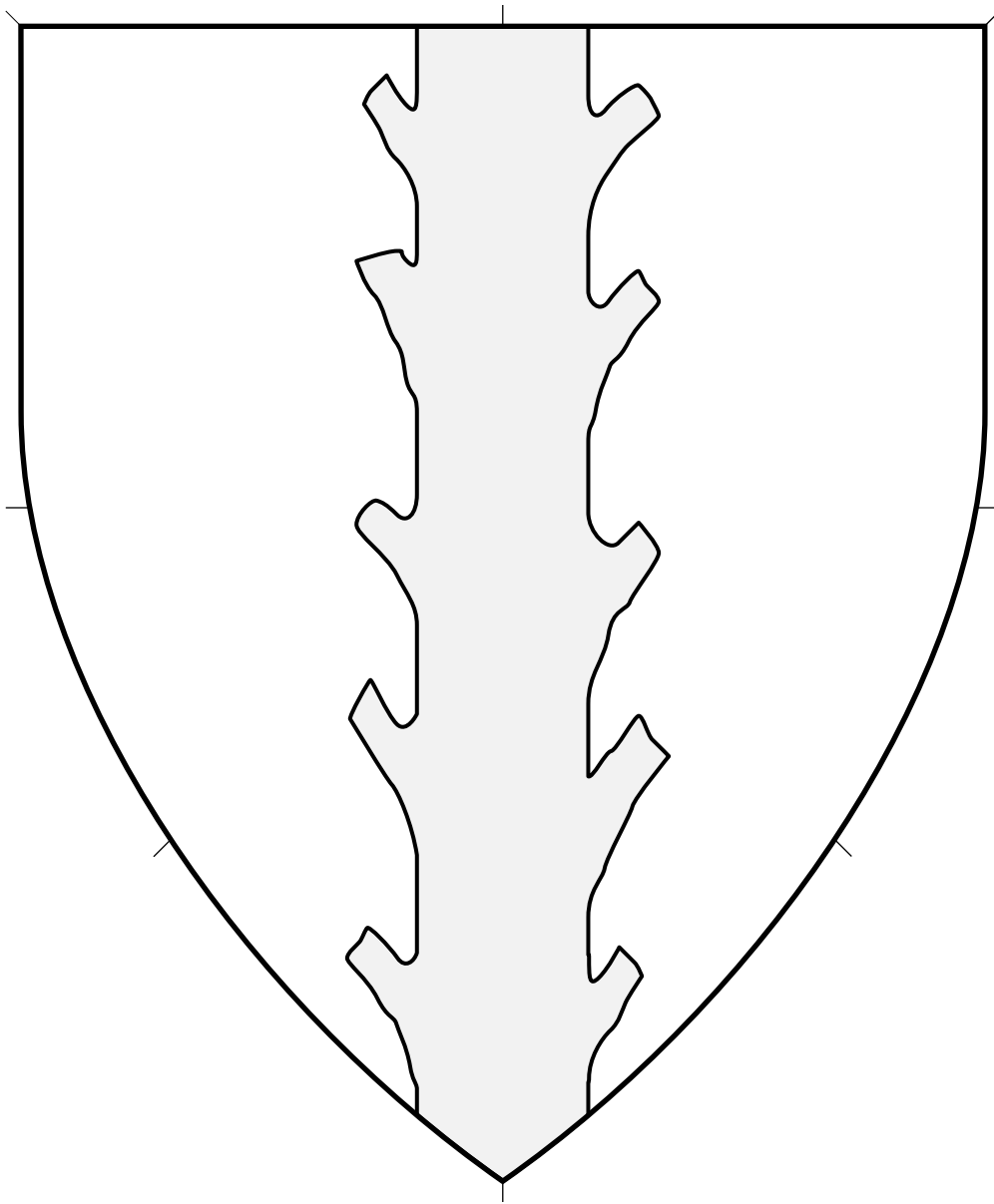

Central ordinary.

Source: Commonplace Book of Heraldry. (Folio 48v.)

Artist: Jean Faucket. Adapted by Mathghamhain Ua Ruadháin.

Pale Raguly (3) 4.494

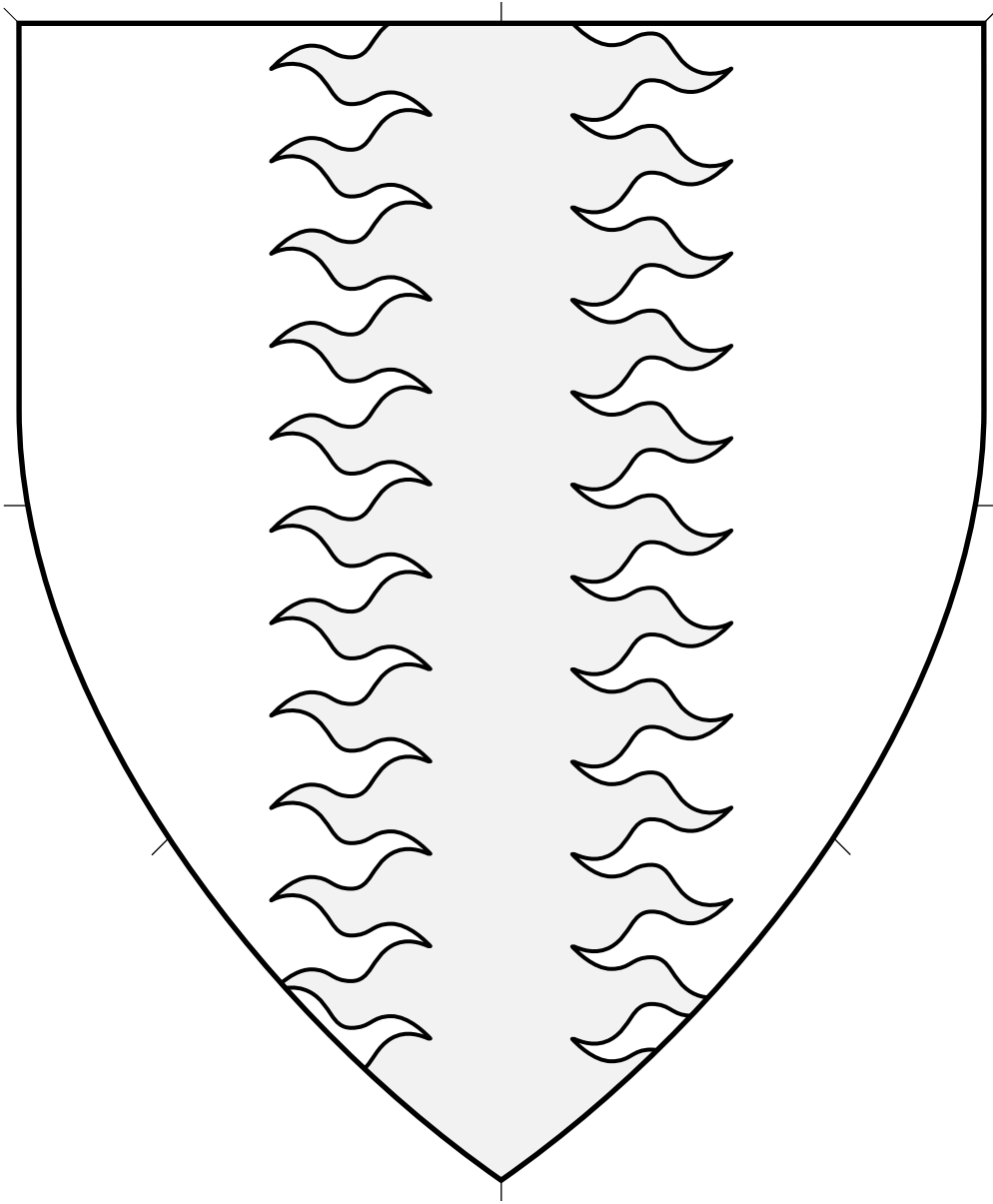

Central ordinary.

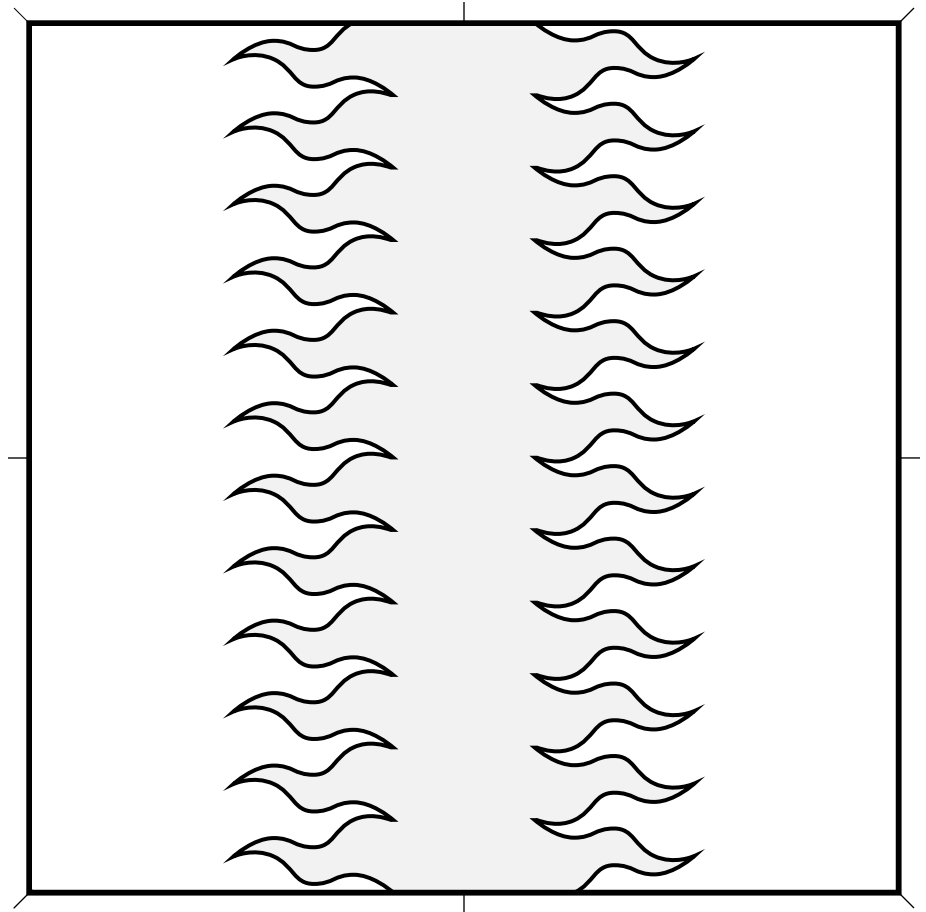

Pale Rayonny (1) • 4.495

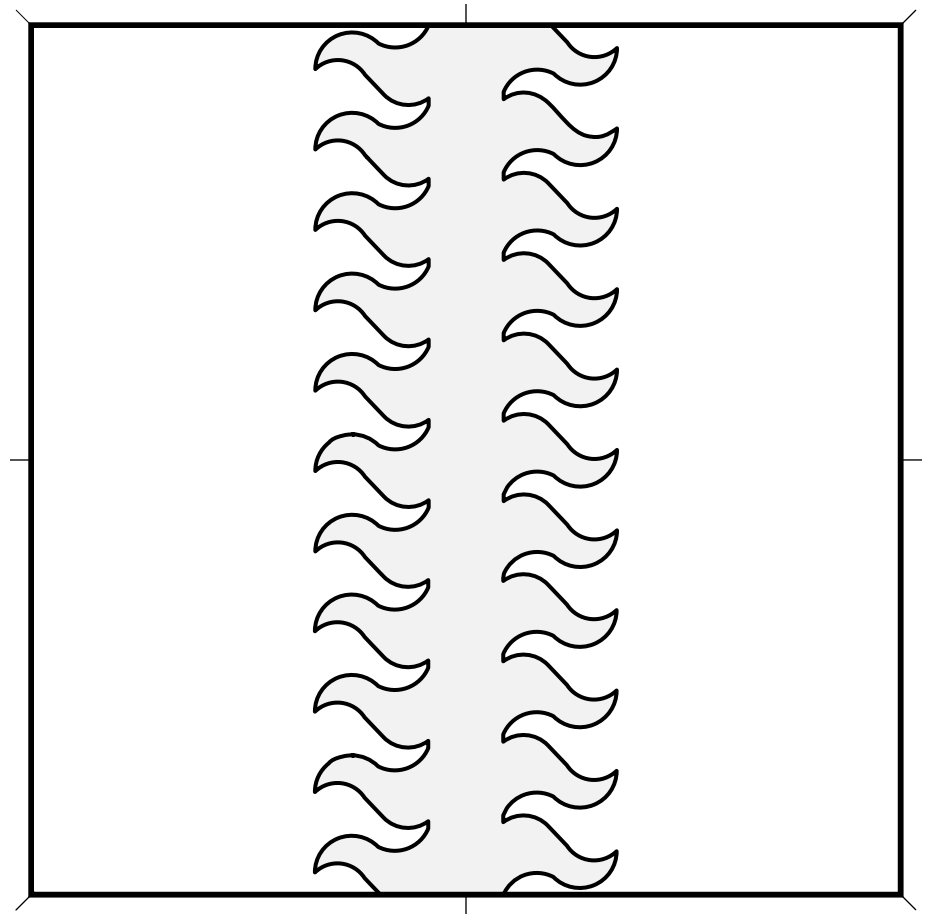
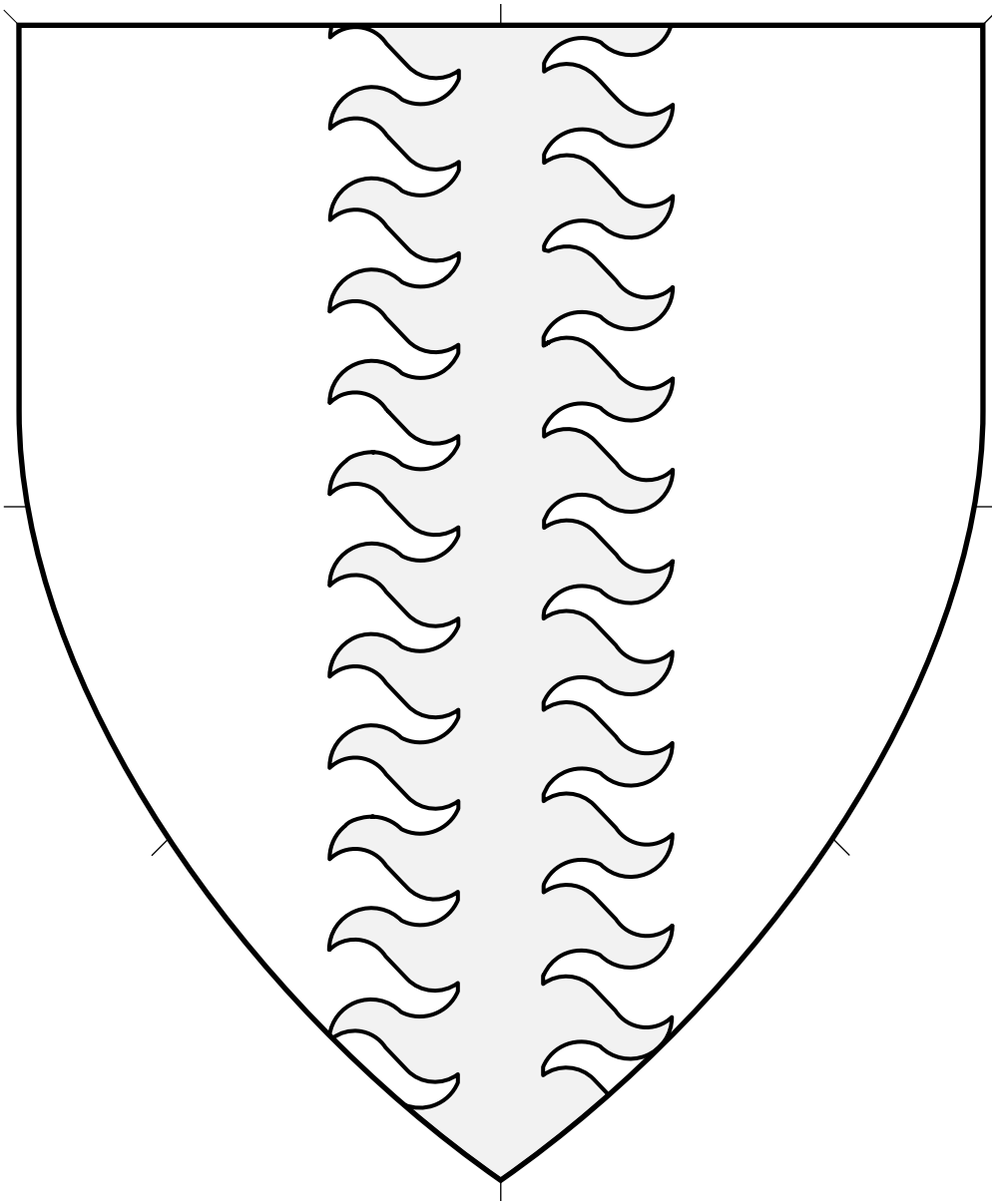

Central ordinary.

Source: Viking Answer Lady SVG Images For Heraldry.
Artist: Gunnvôr silfrahárr. Adapted by Mathghamhain Ua Ruadháin.

Pale Rayonny (2) 4.496

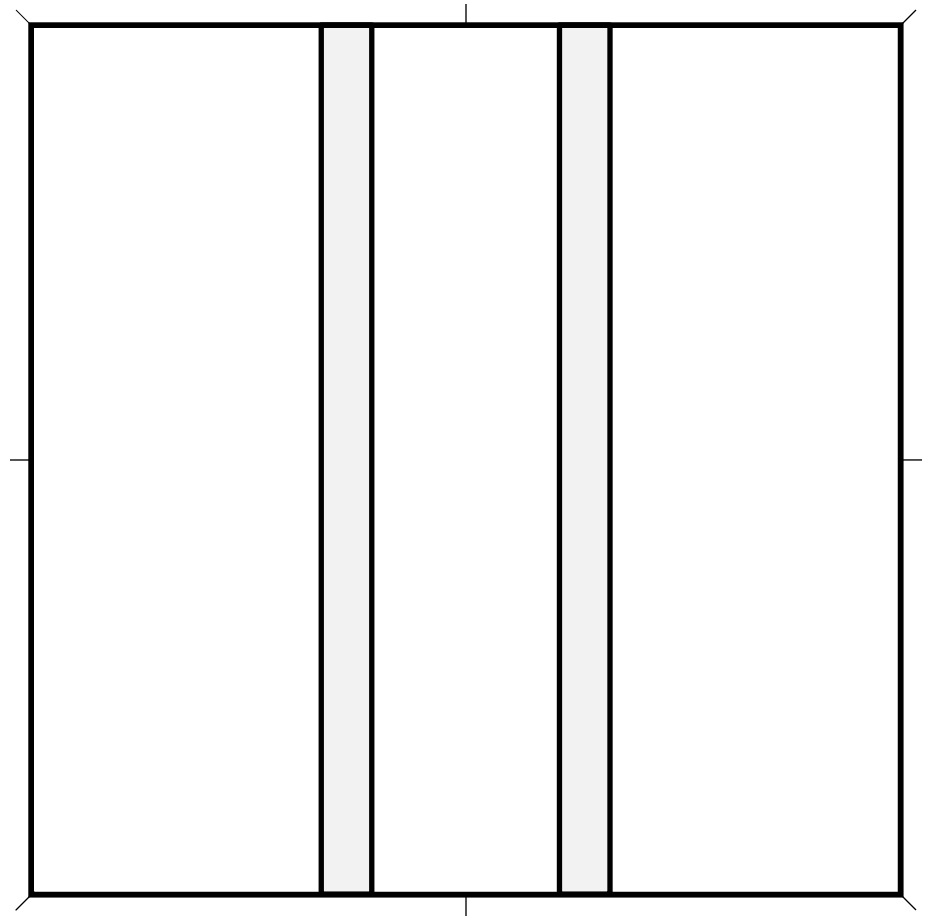
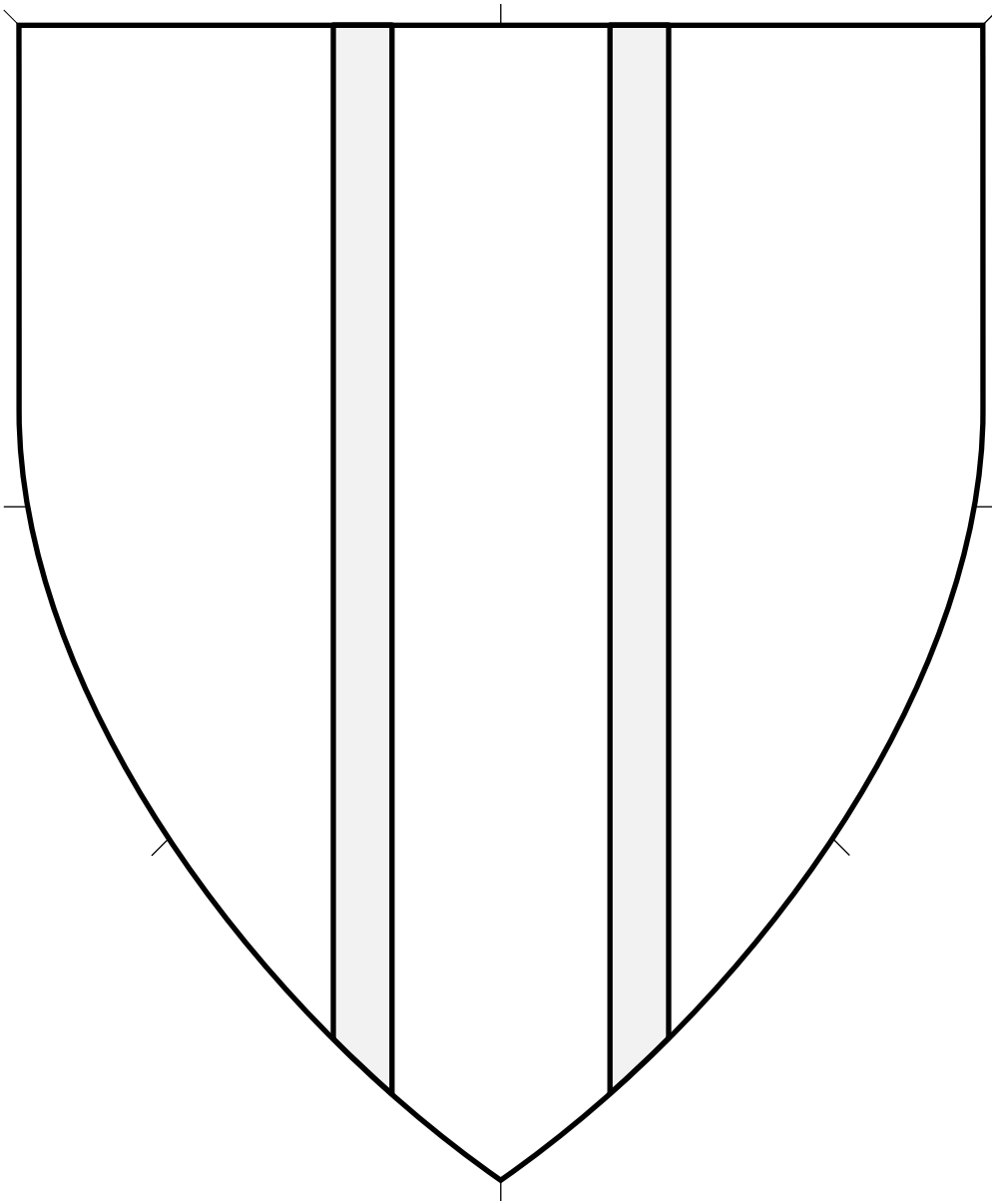

Central ordinary.

Pale Voided 4.497

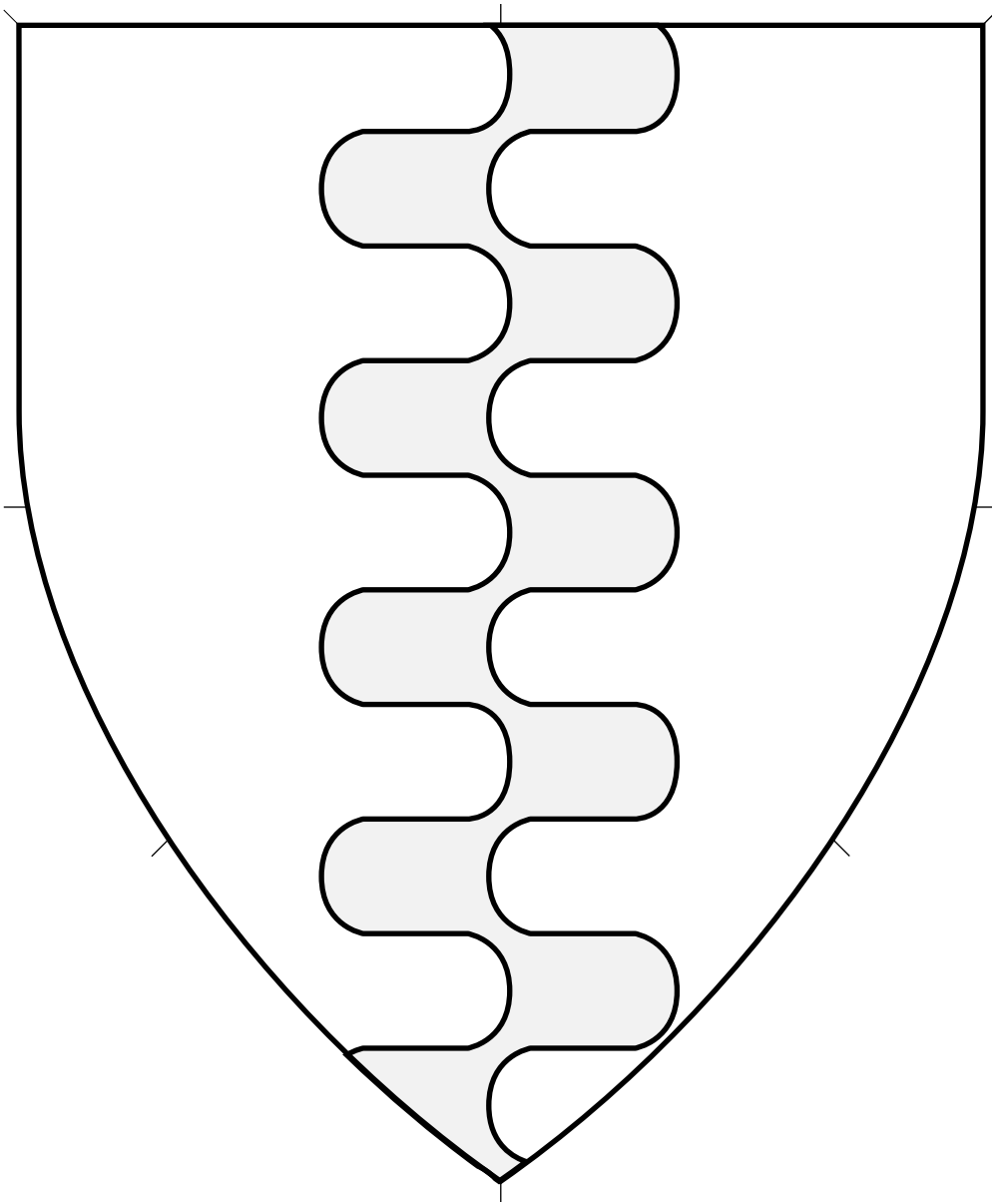

Central ordinary.

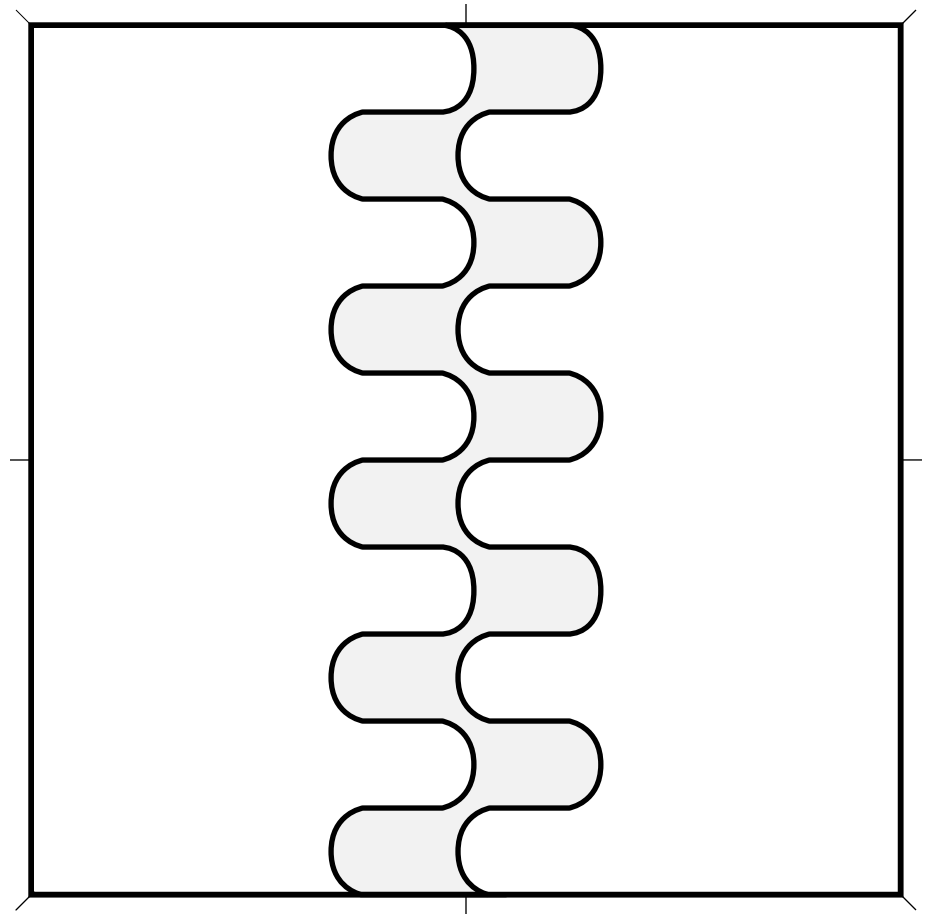

Pale Wavy (1) 4.498

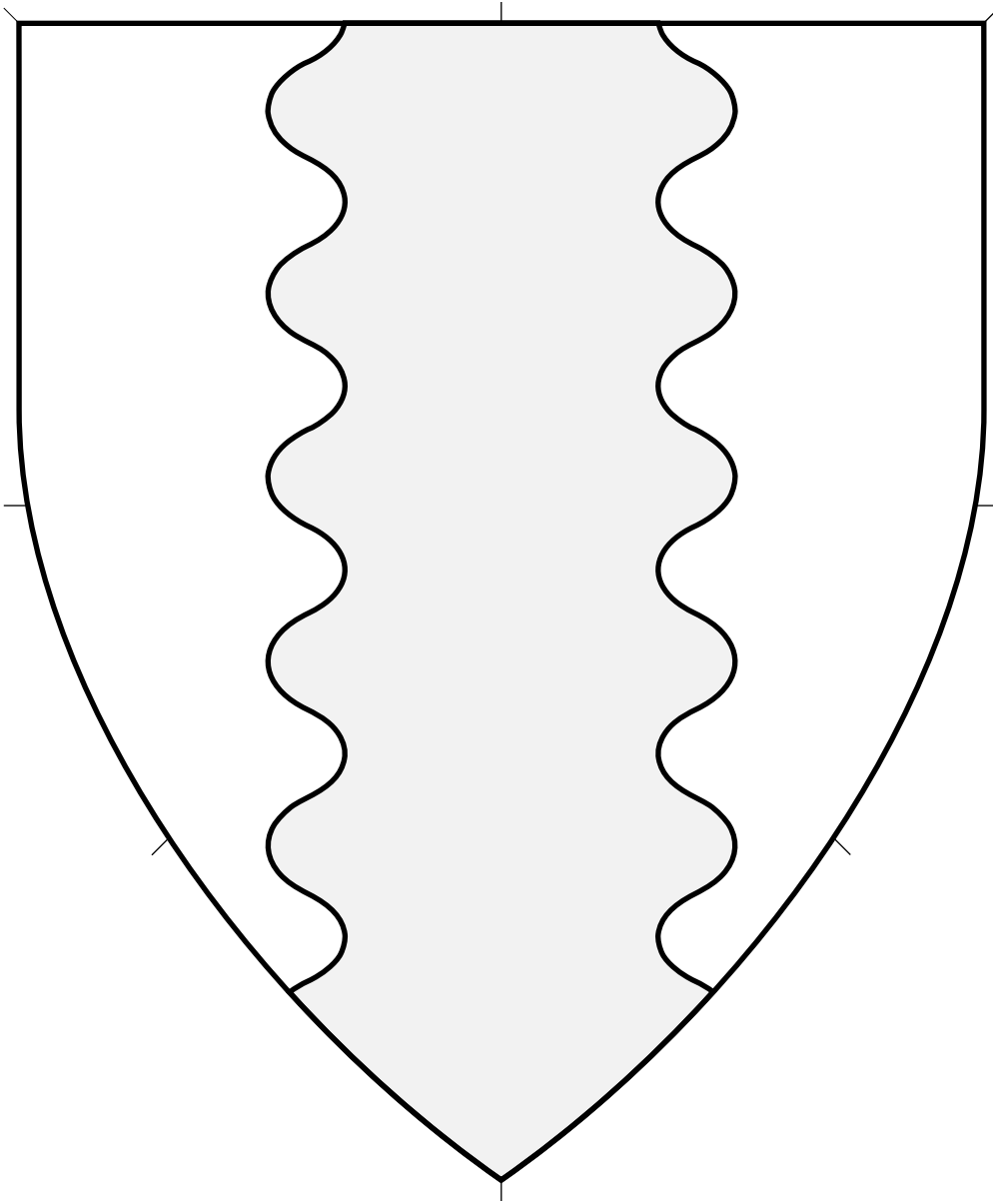

Central ordinary.

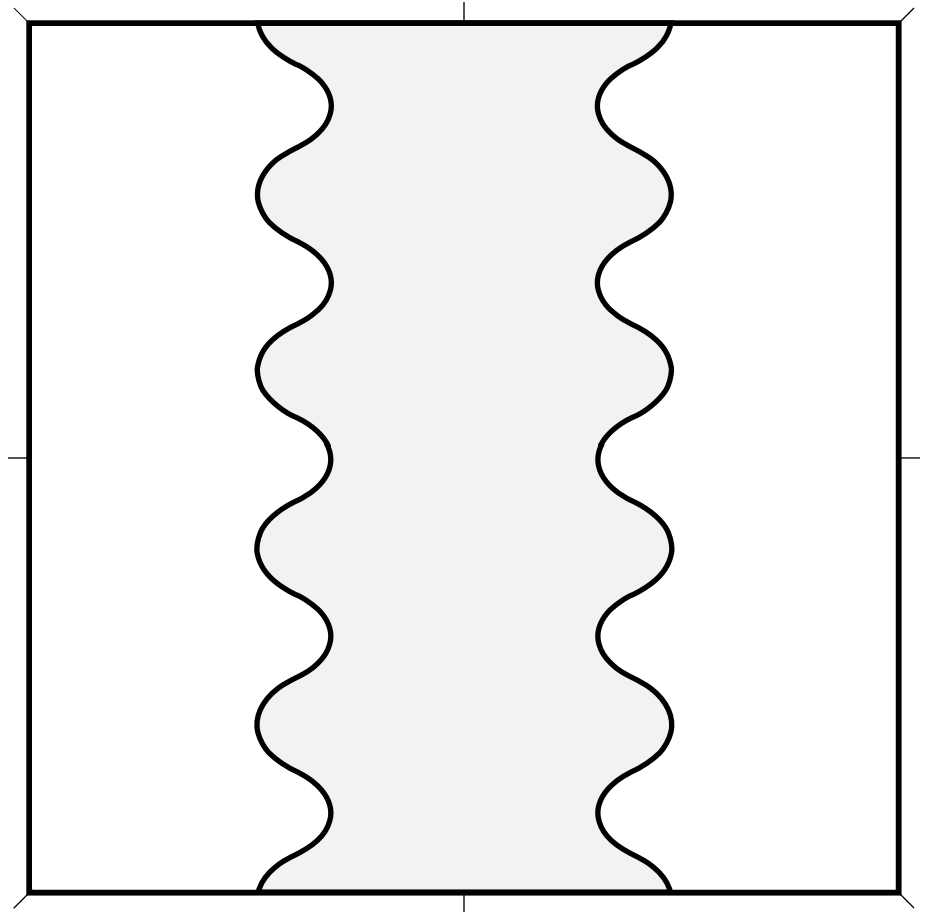

Pale Wavy (2) • 4.499

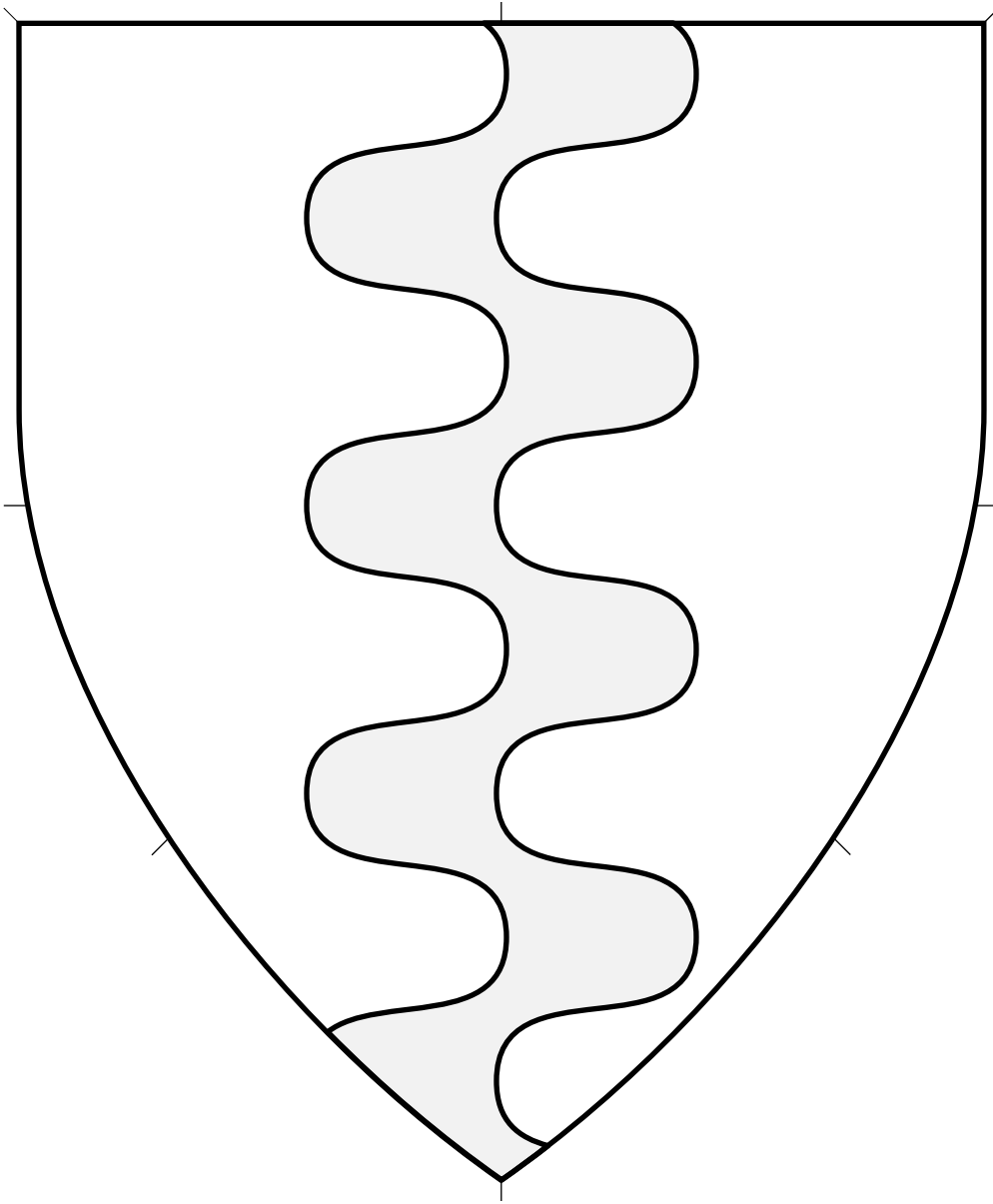

Central ordinary.

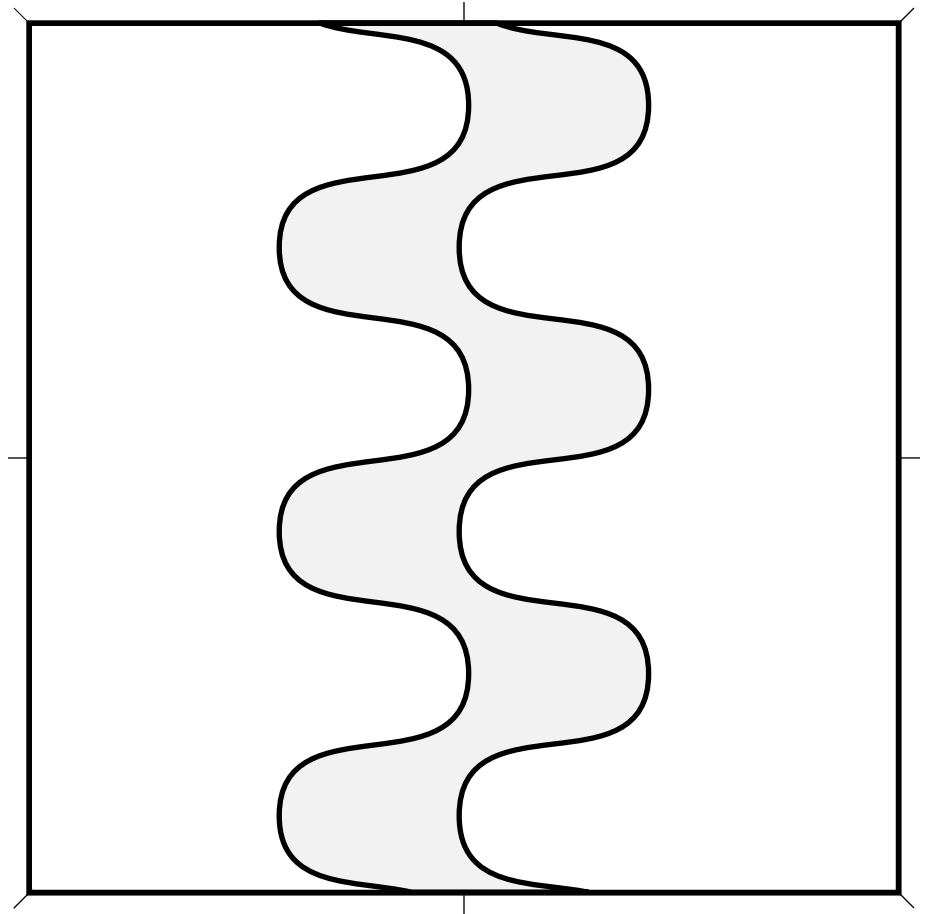

Pale Wavy (3) • 4.500

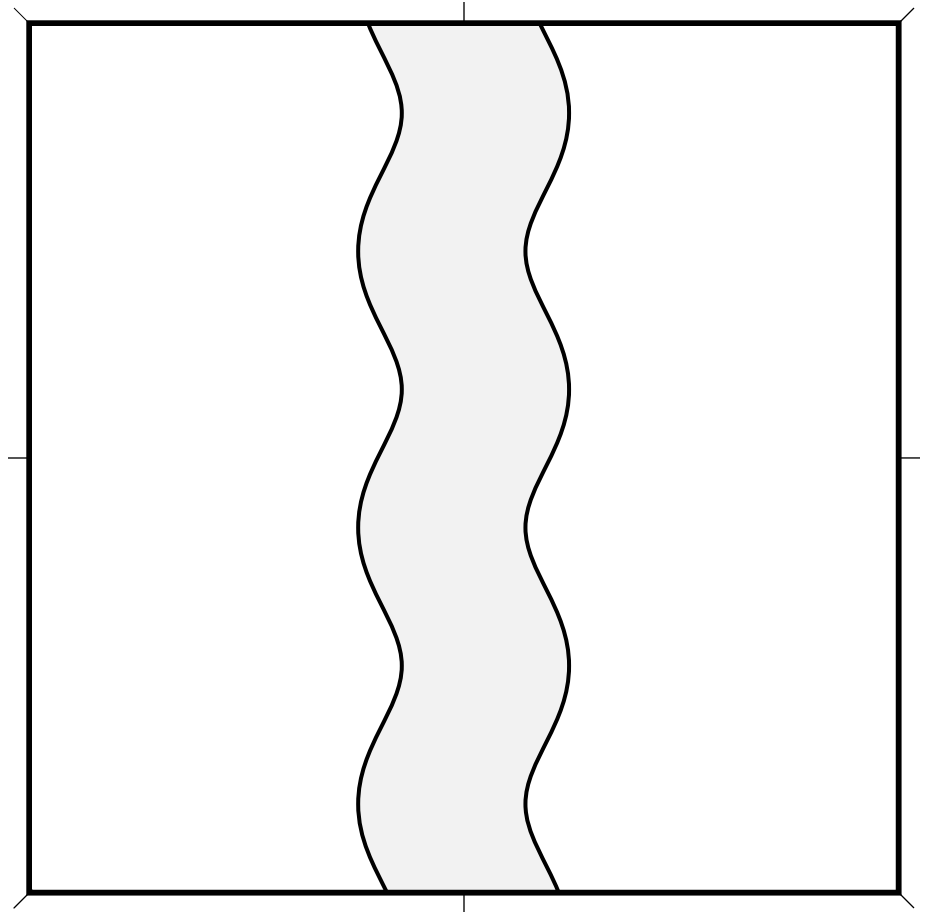
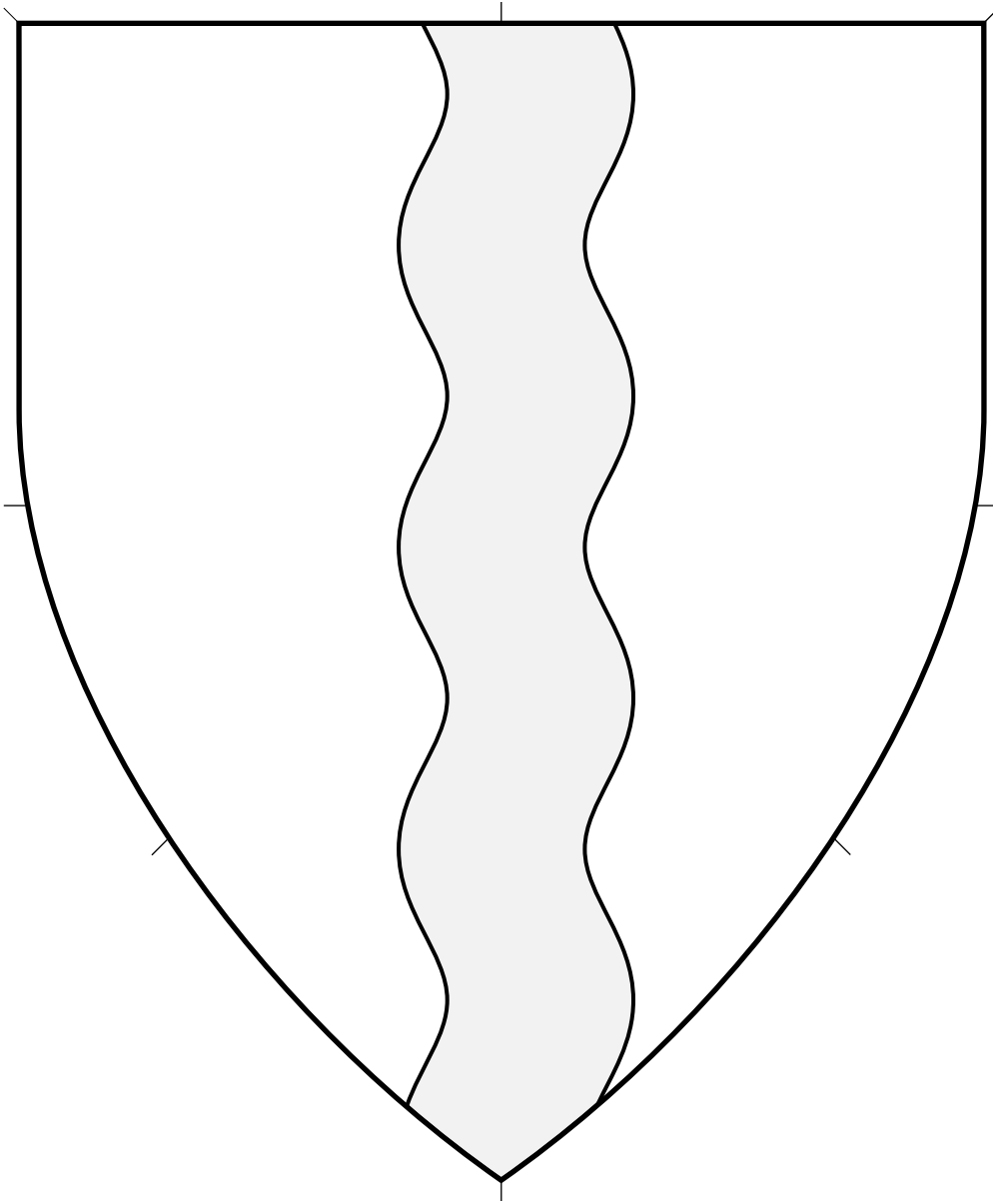

Central ordinary.

Pale Wavy (4) • 4.501

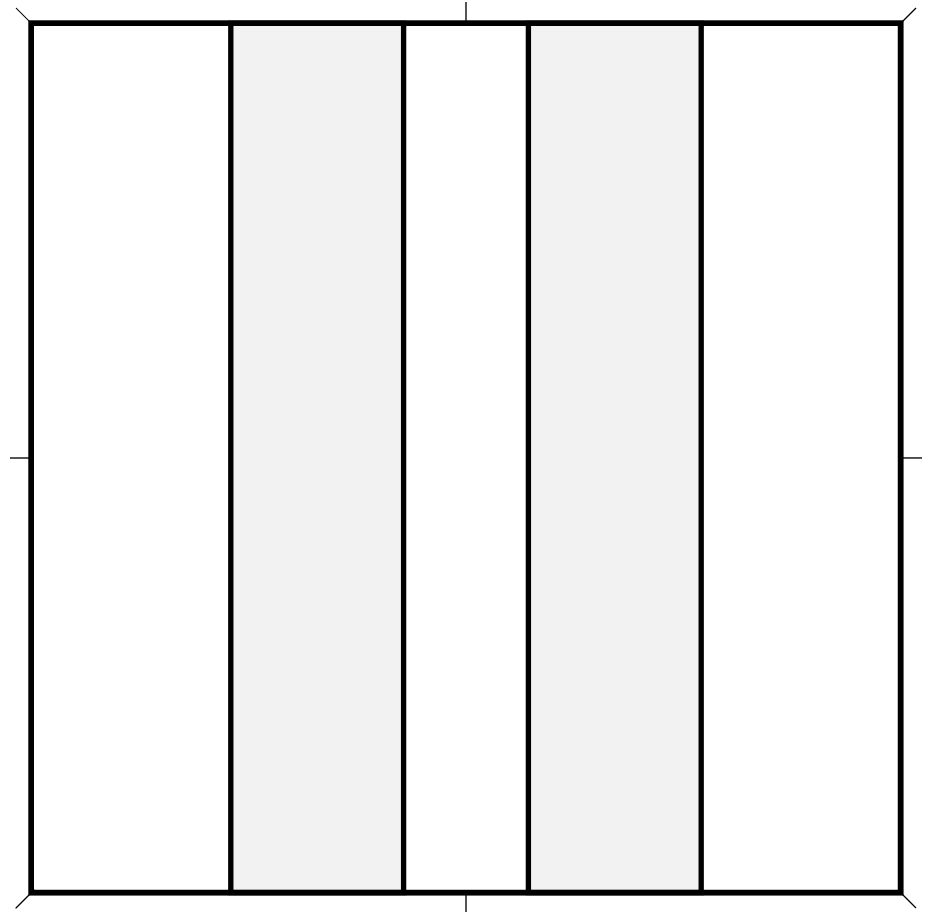
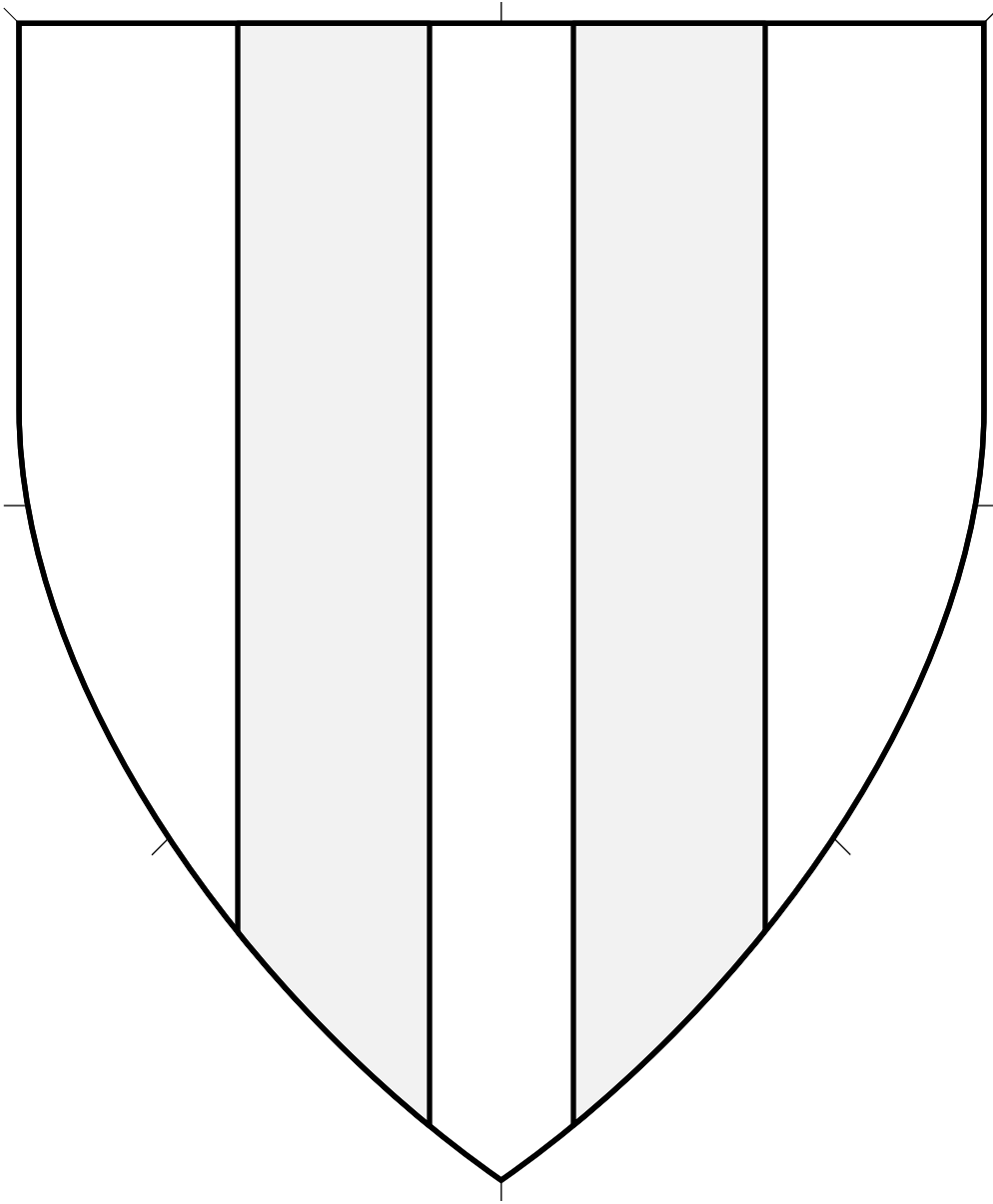

Central ordinary.

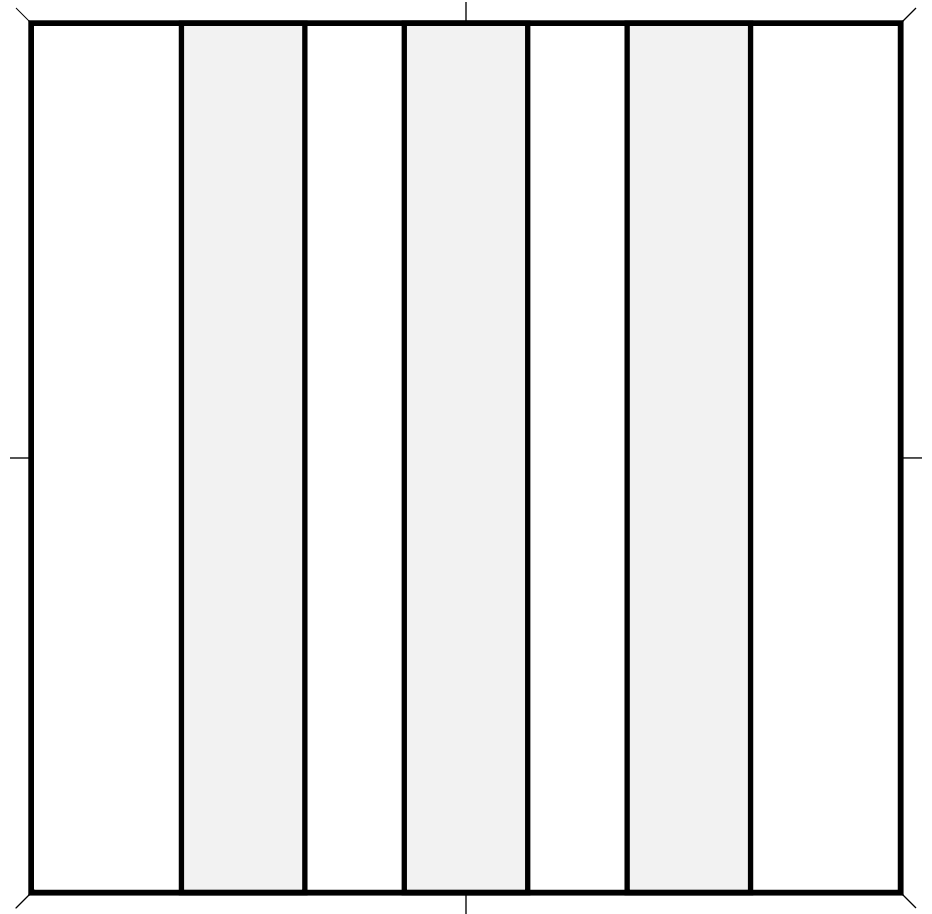
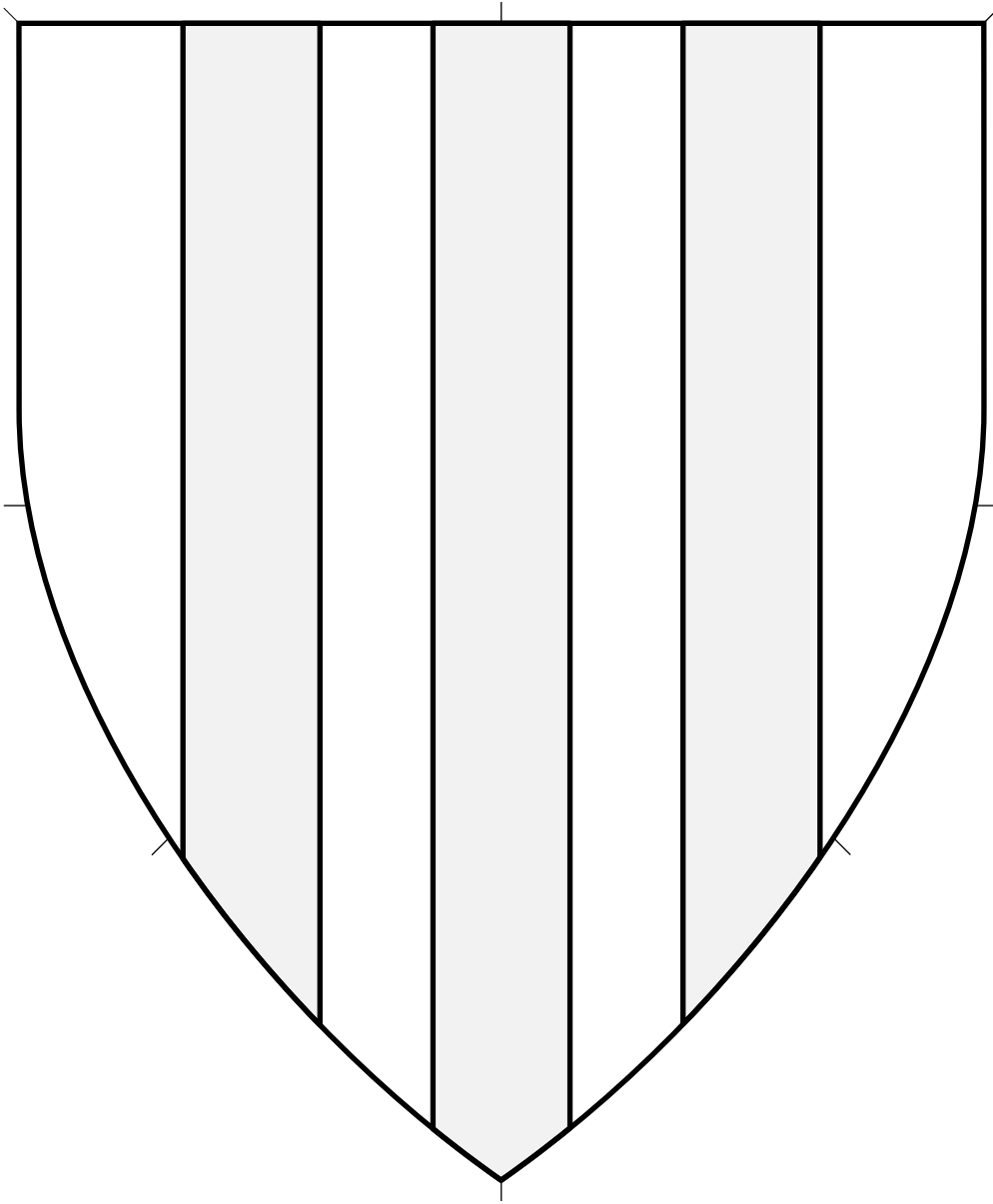

Central ordinary.

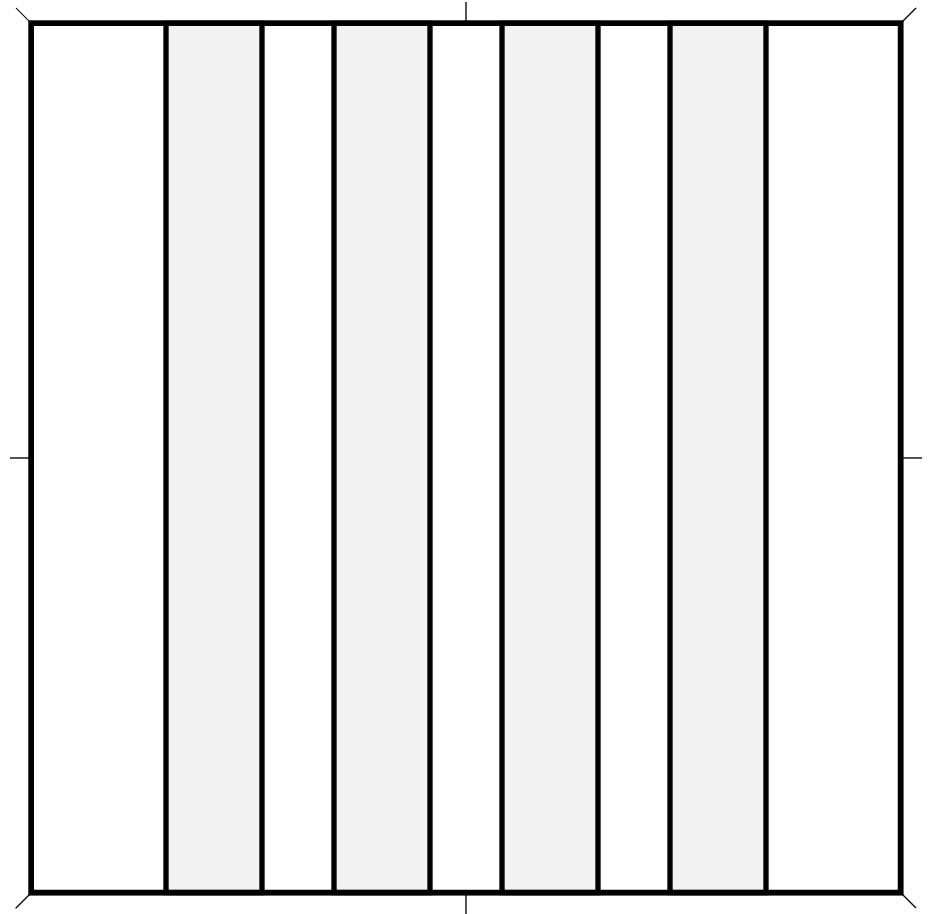
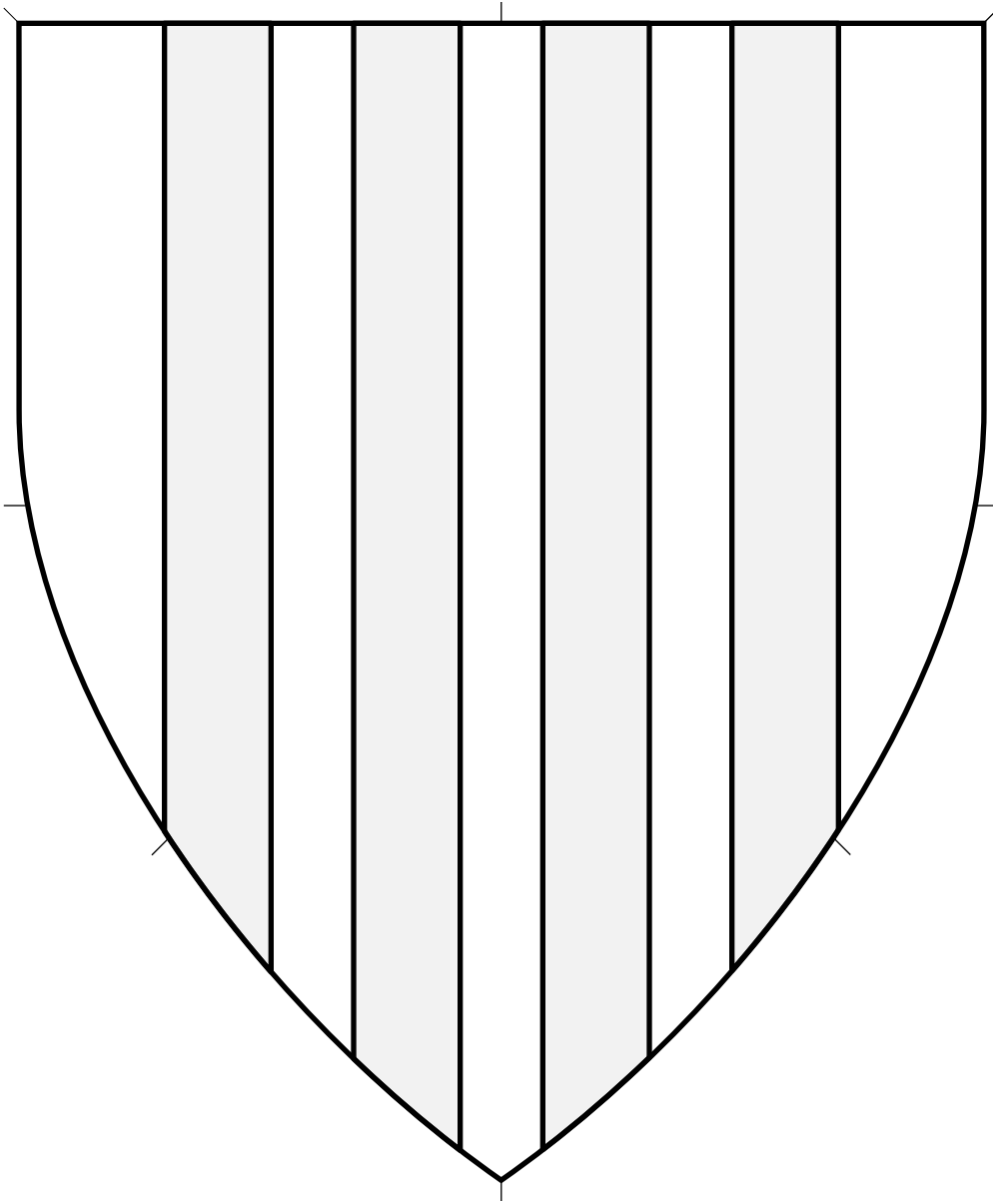

Central ordinary.

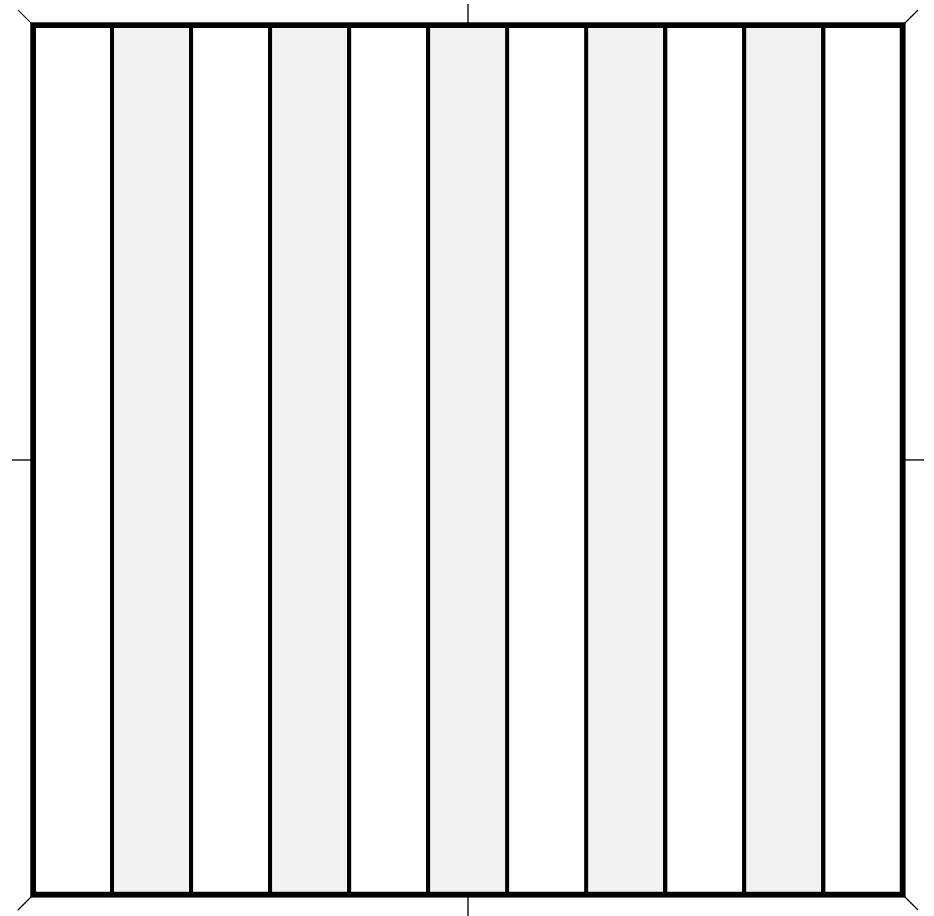
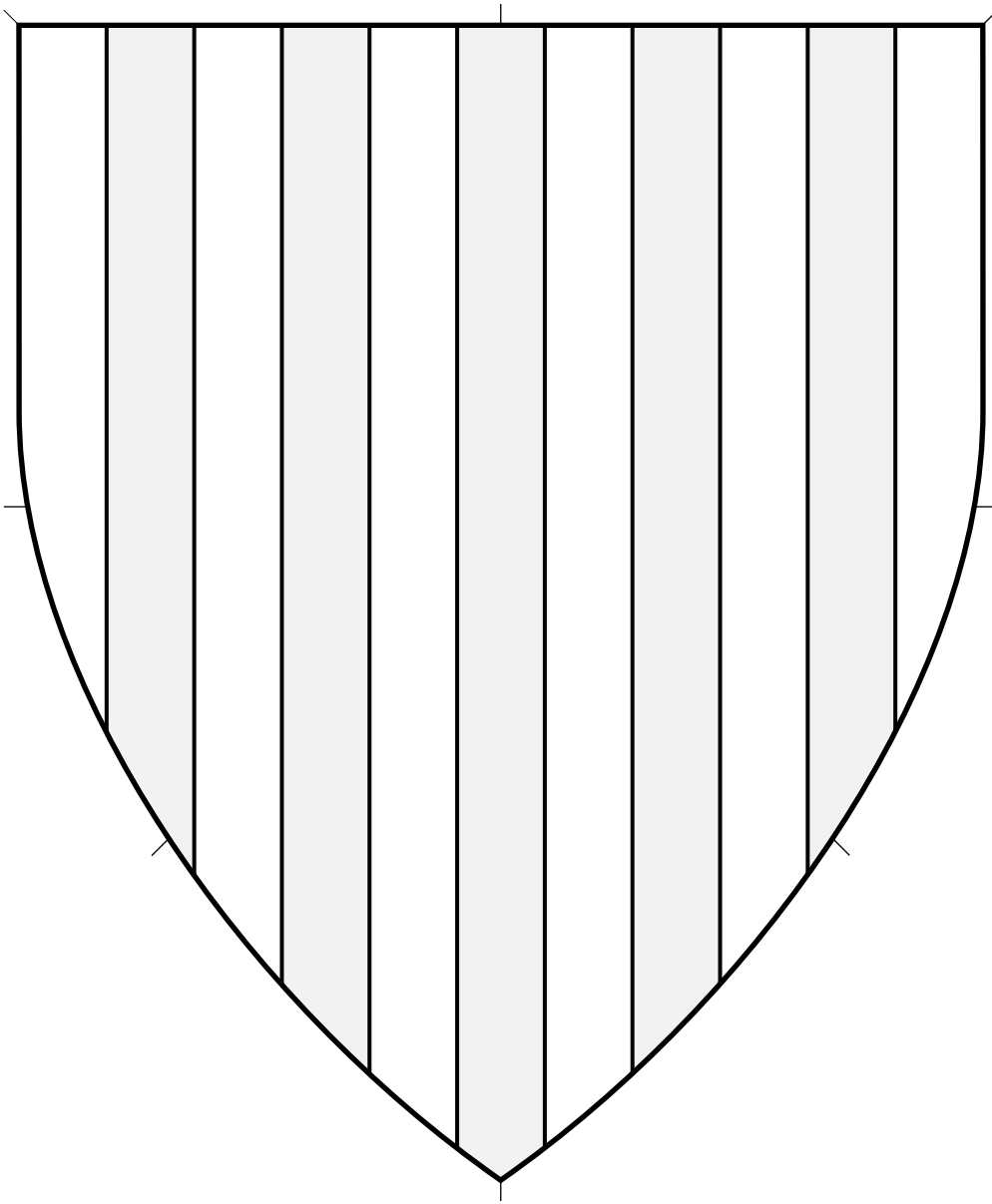

Central ordinary.

Source: Insignia Equitum Gallici Ordinis Sancti Michaelis.
Artist unknown. (Page 13.)

Pallets, 5 4.505

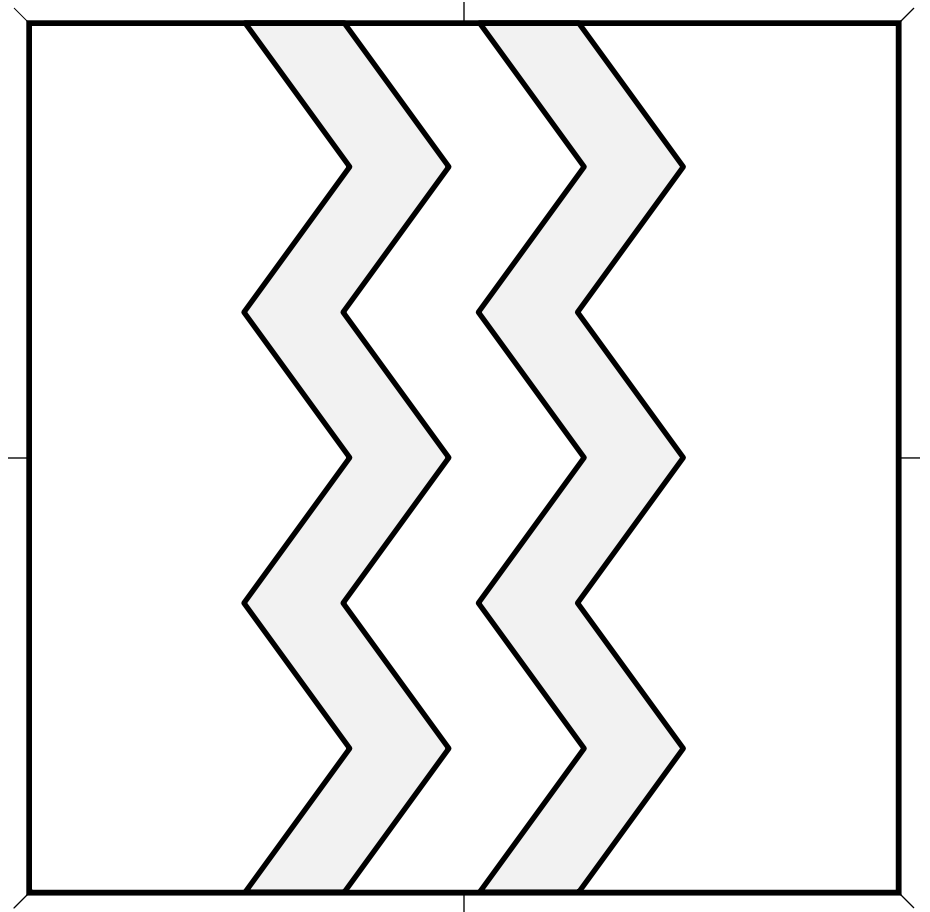
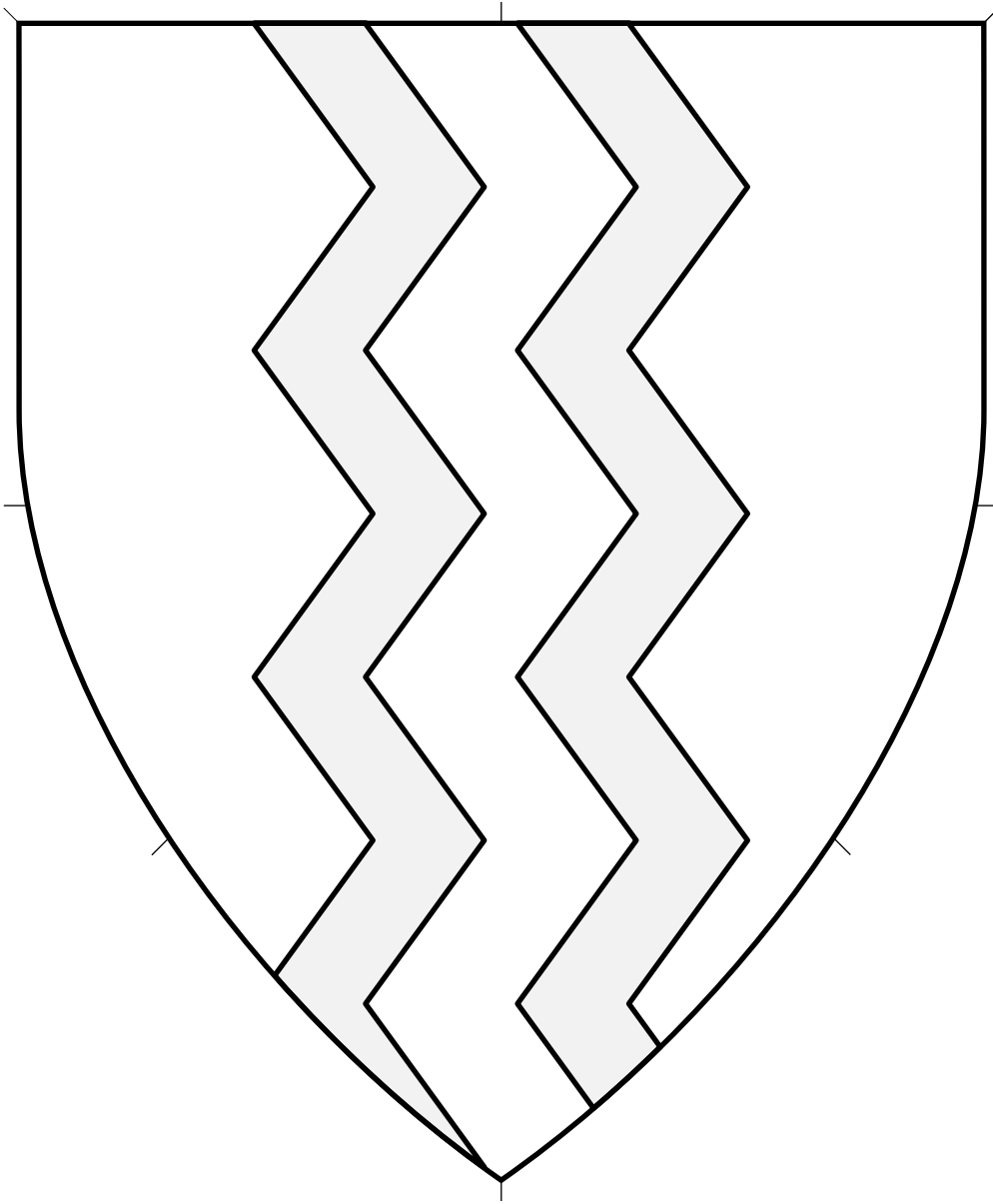

Central ordinary.

Pallets Dancetty, Two 4.506

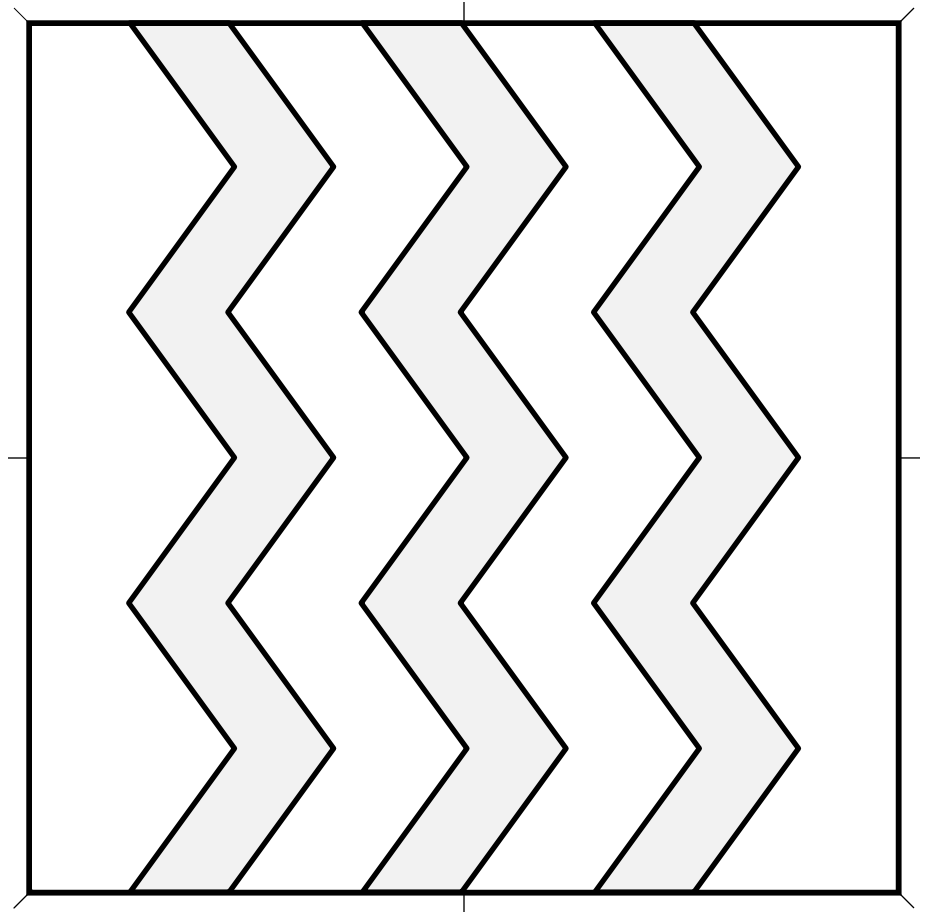
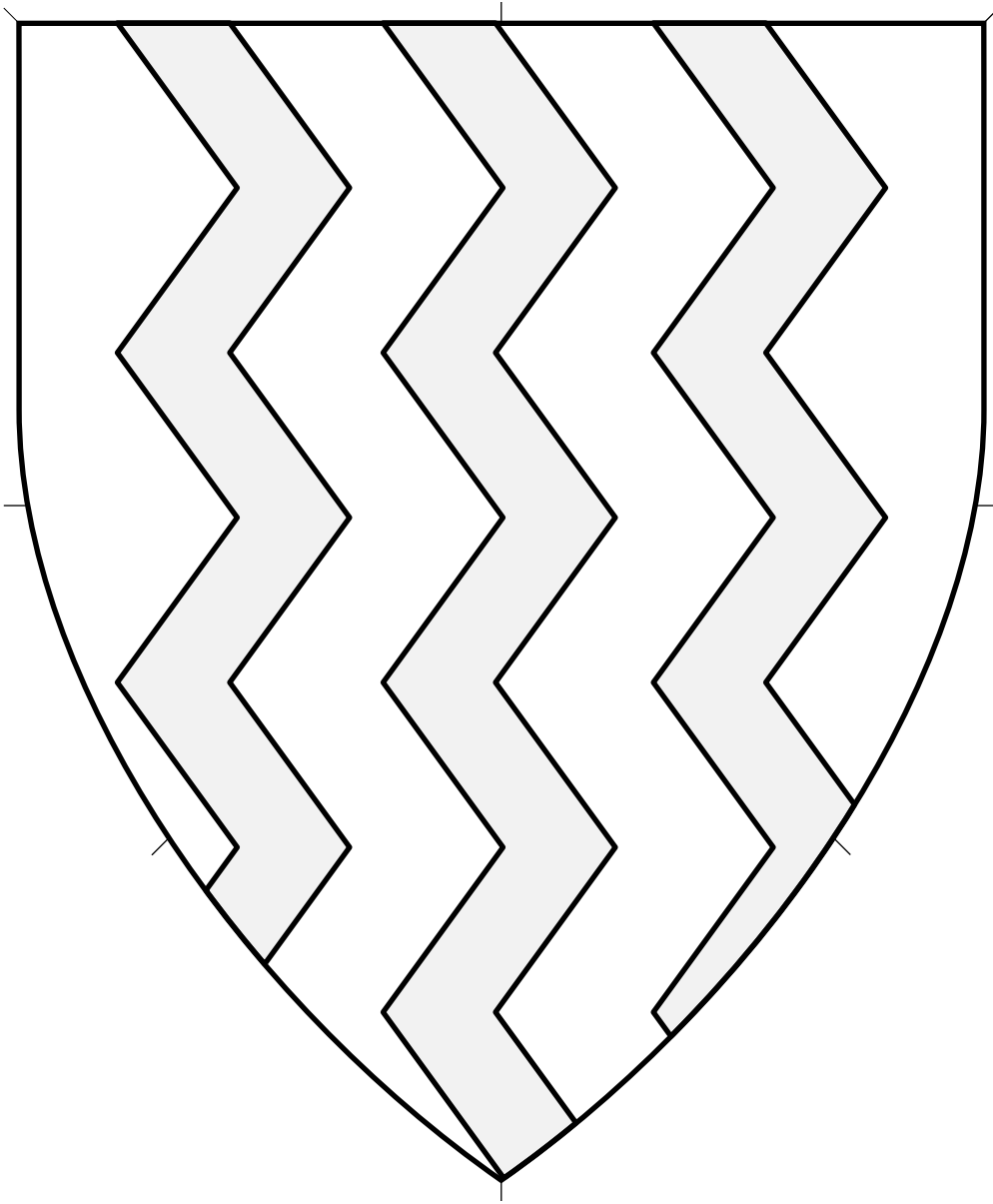

Central ordinary.

Pallets Dancetty, Three • 4.507

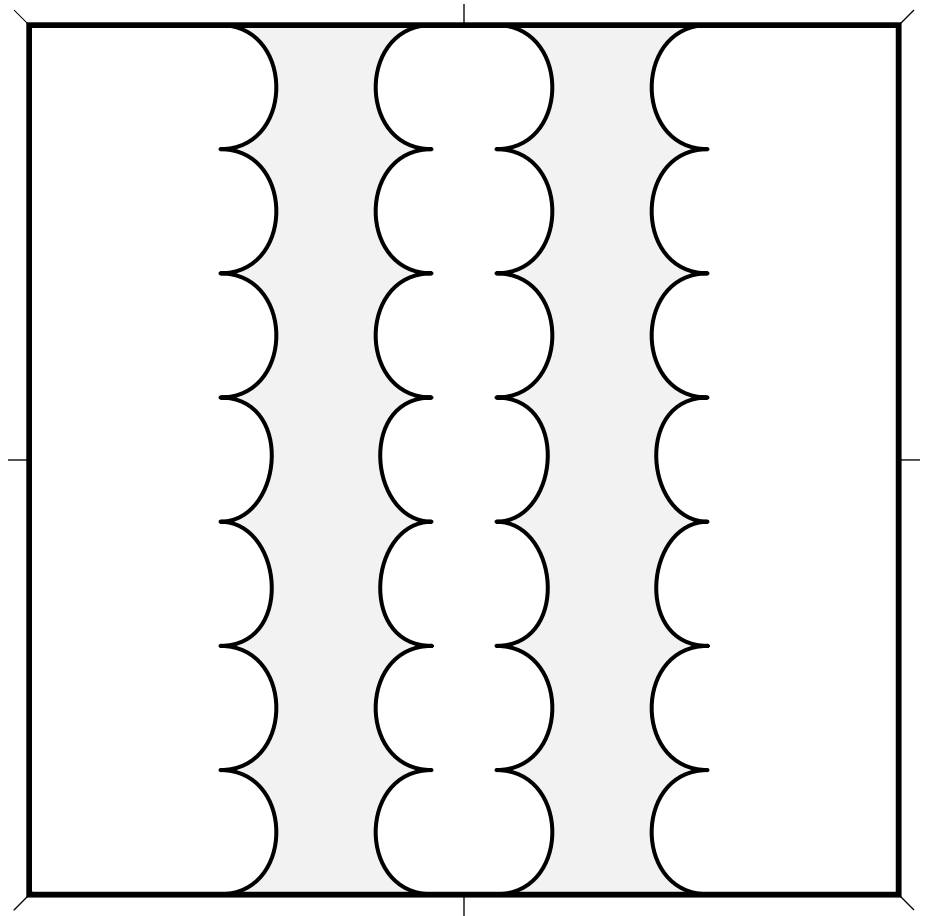
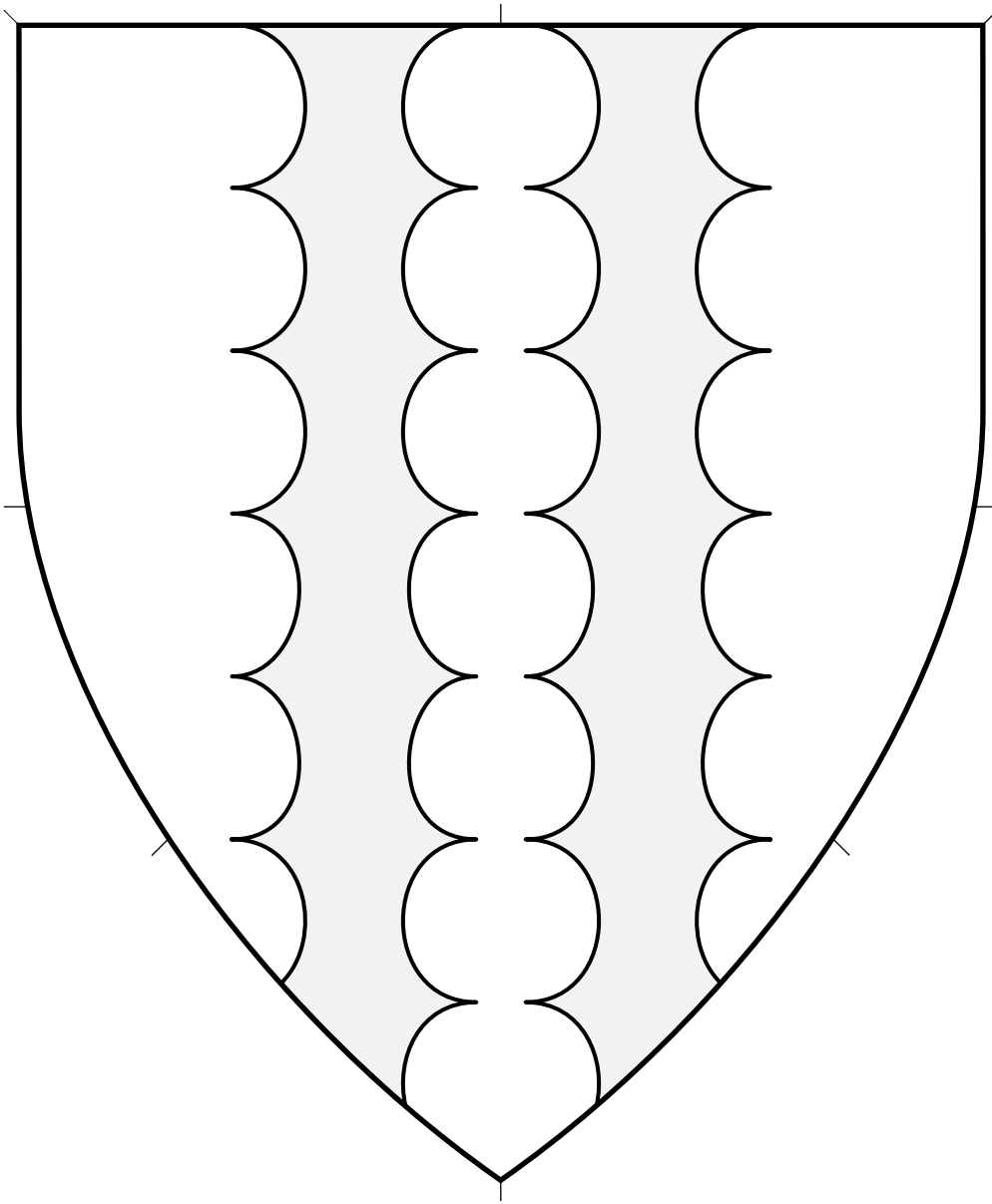

Central ordinary.

Pallets Engrailed, Two 4.508

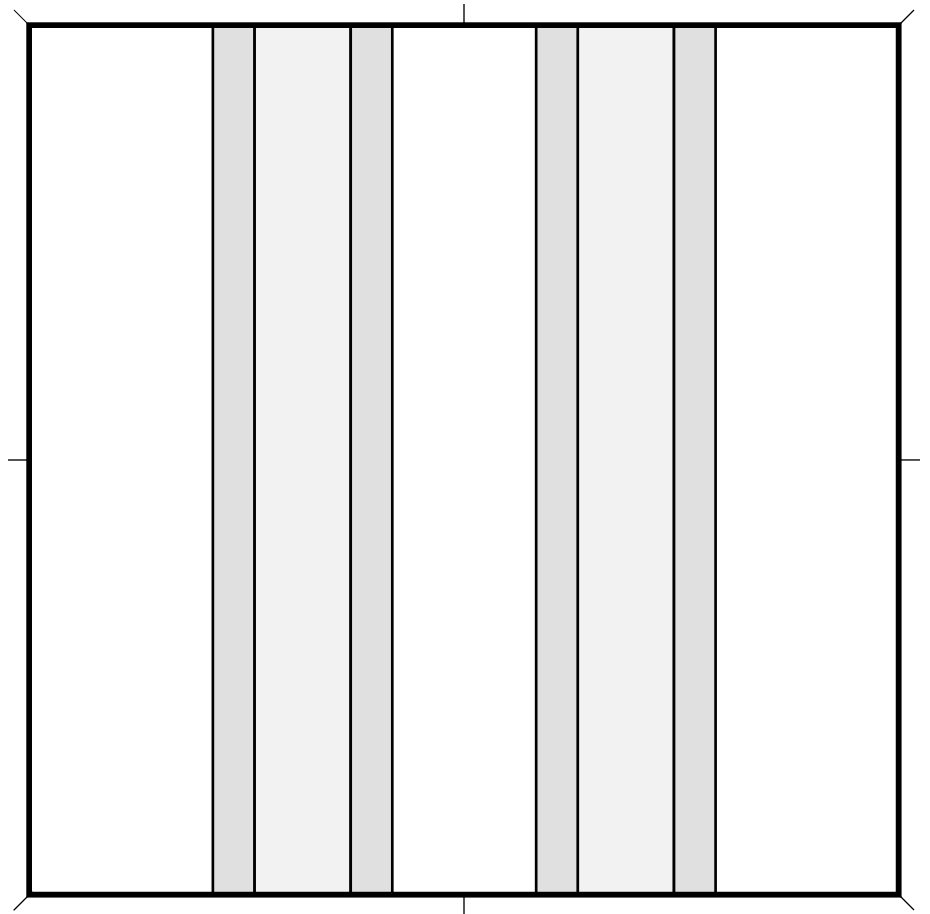
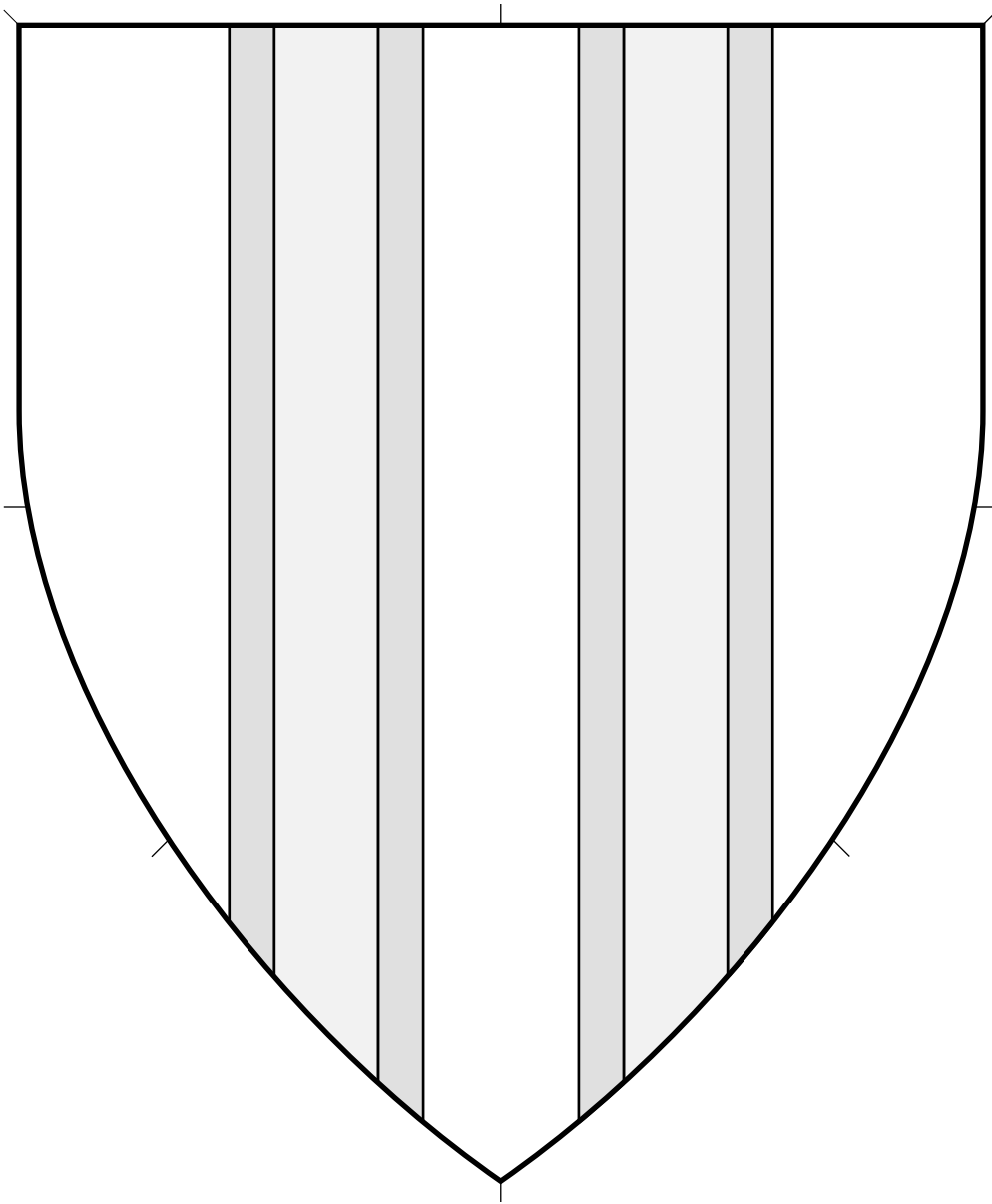

Central ordinary.

Pallets Fimbriated, Two • 4.509

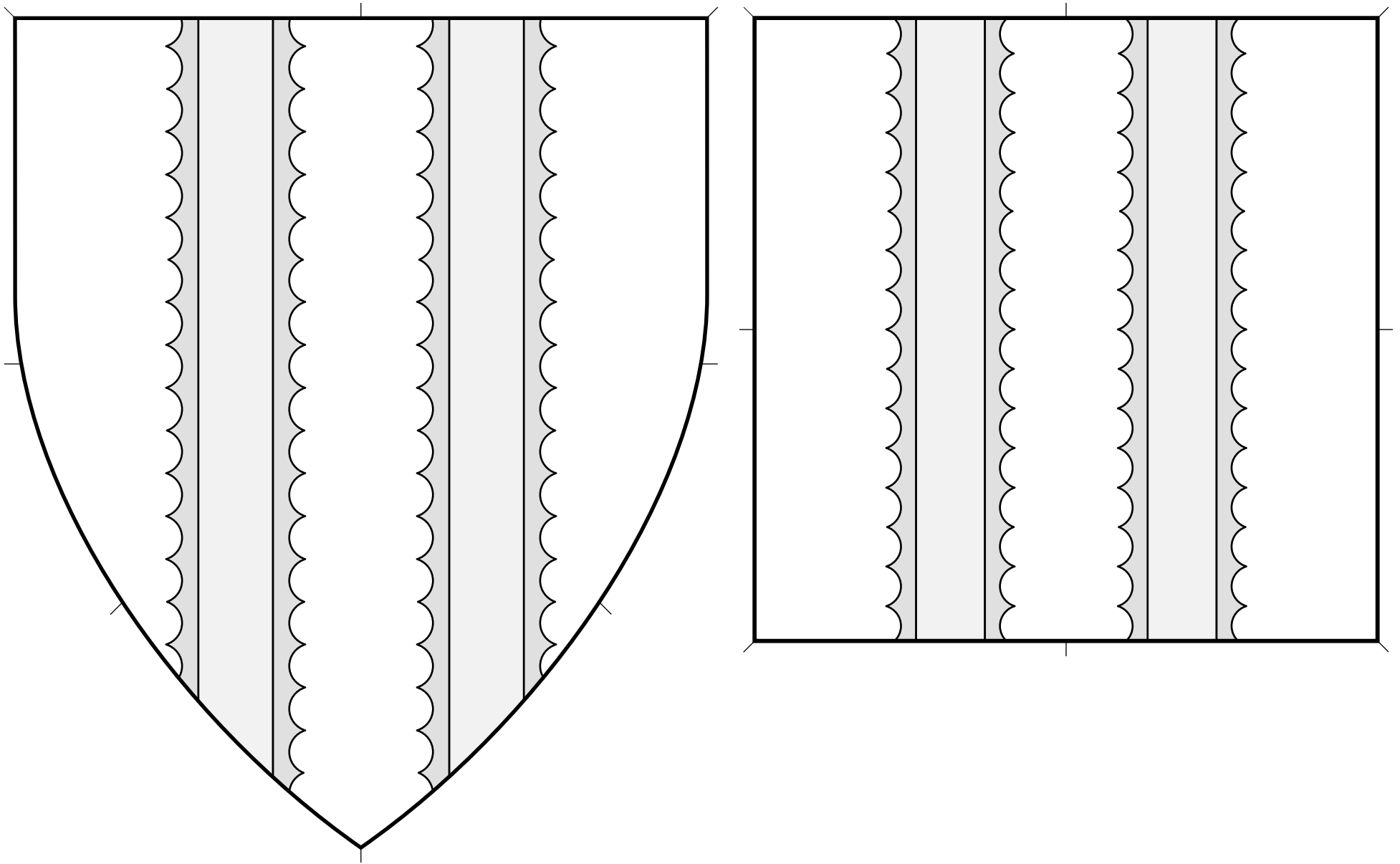

Central ordinary.

Source: Armorial Lorrain de la Première Moitié du XVIe Siècle. (Page 150.) Artist unknown.

Pallets Fimbriated Engrailed, Two 4.510

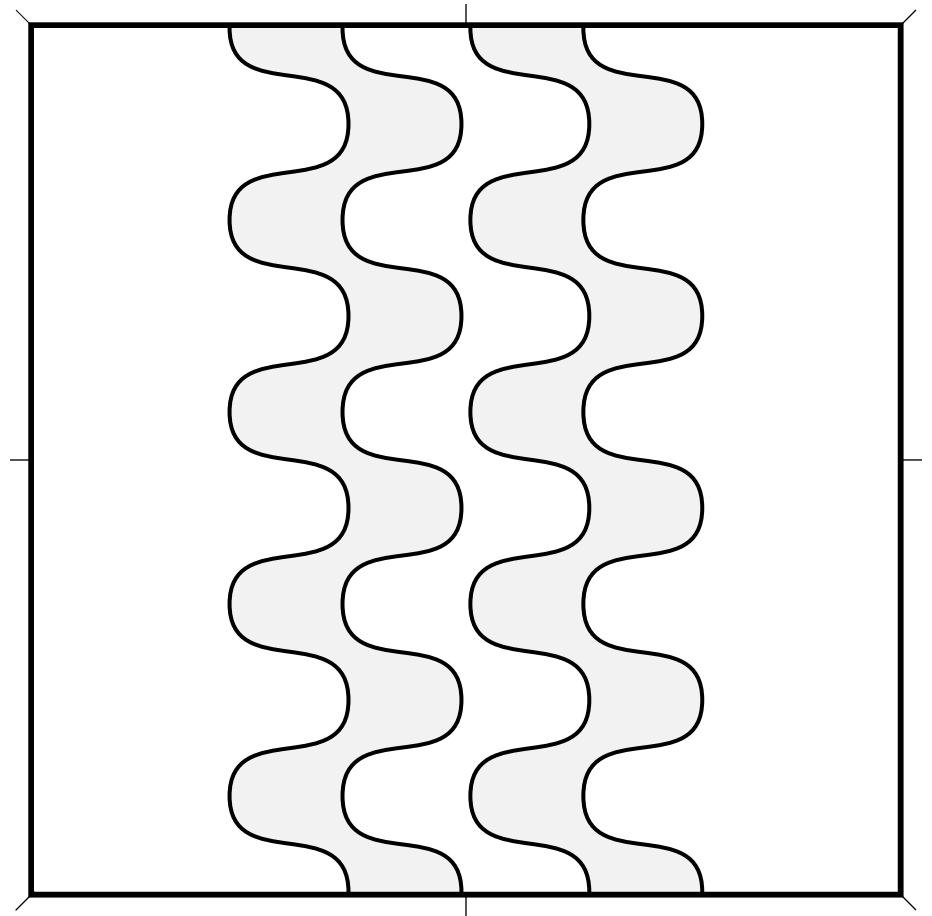
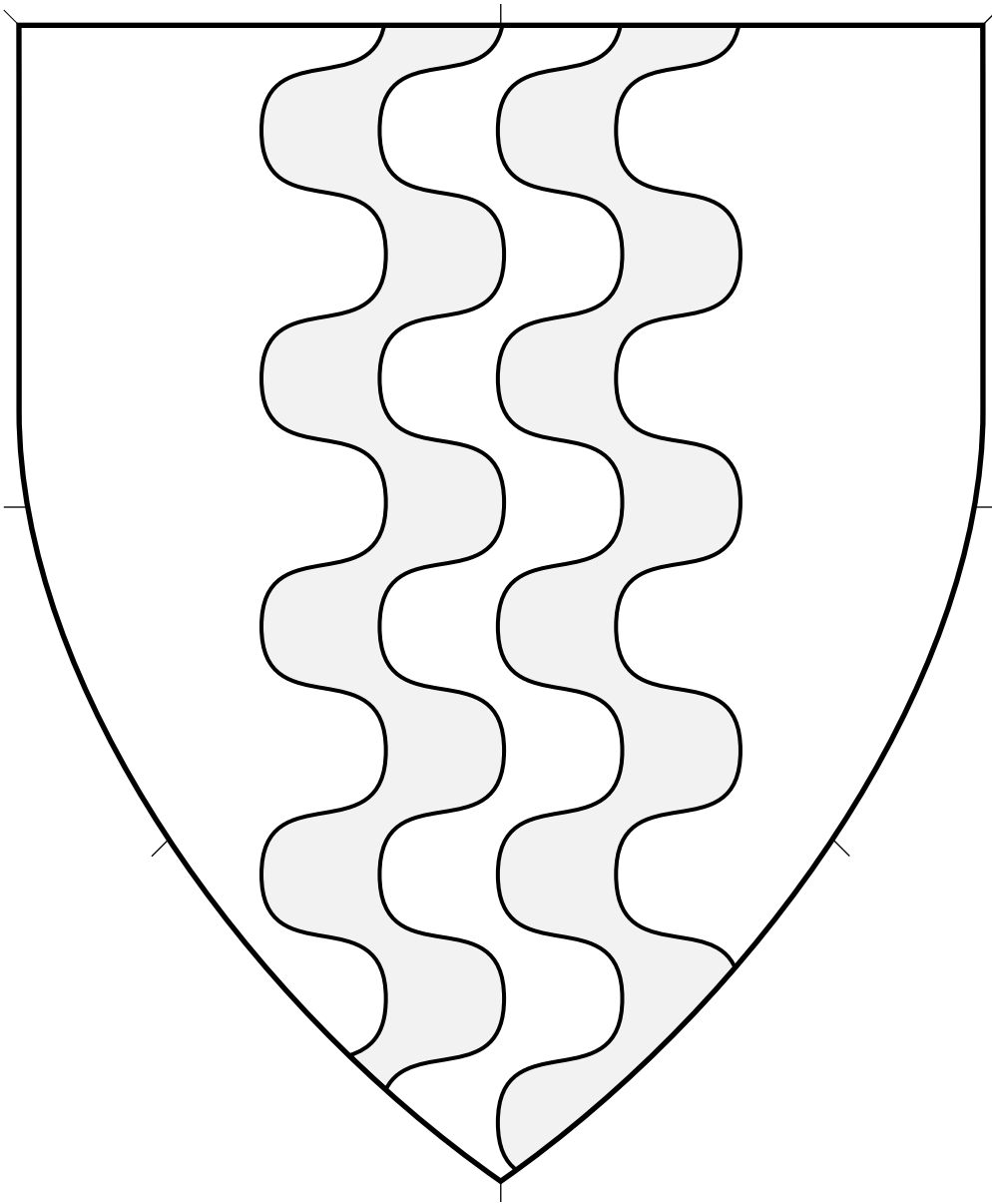

Central ordinary.

Pallets Wavy, 2 • 4.511

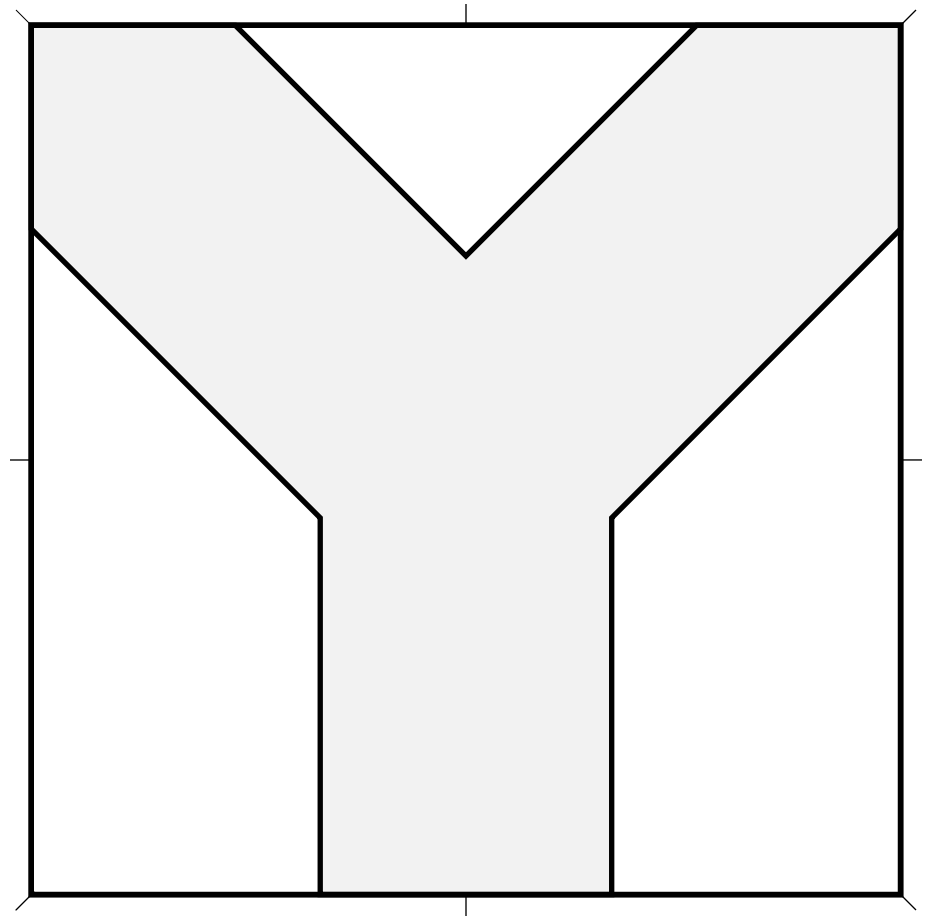
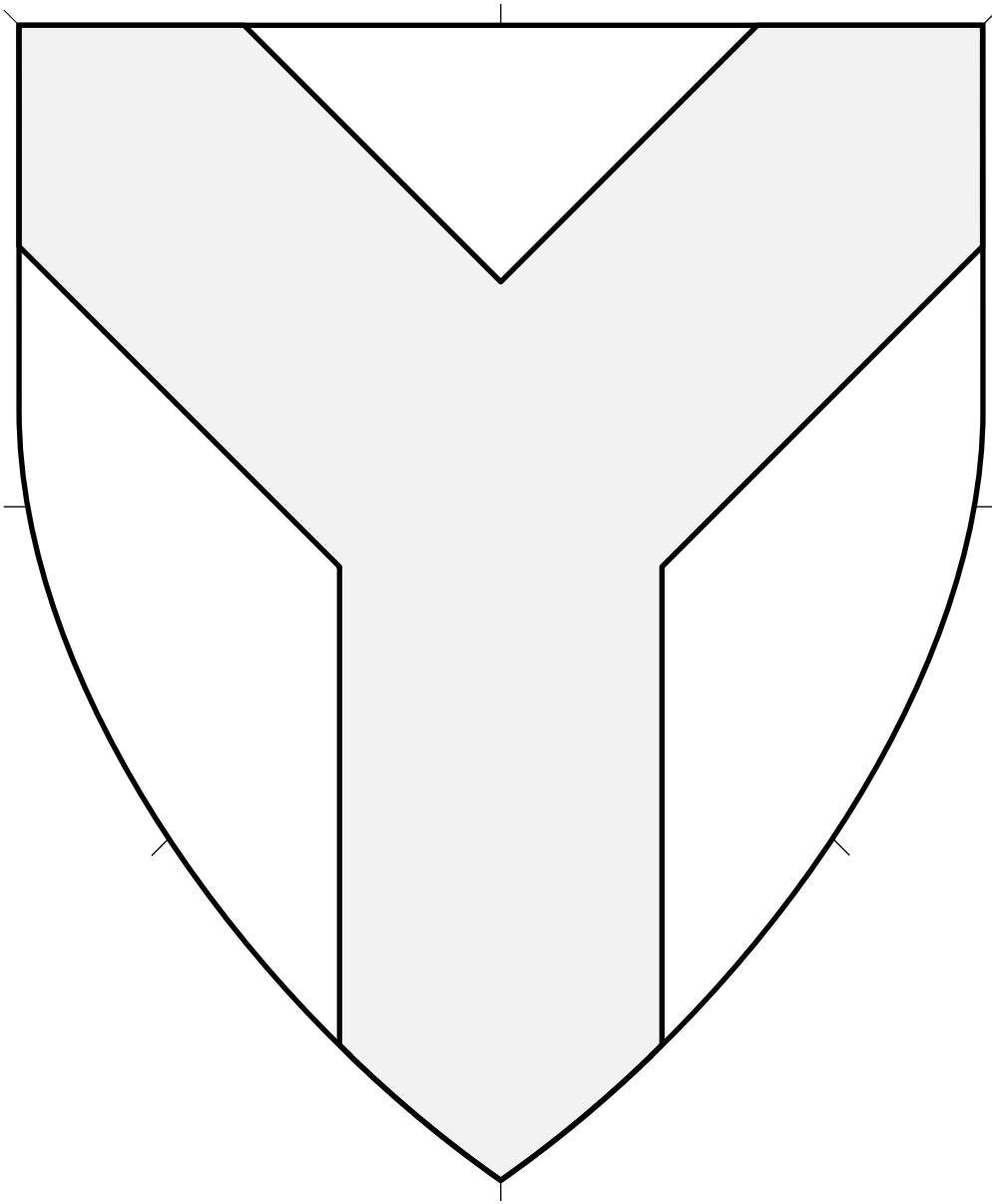

Central ordinary. The width of each arm is typically a third of the width of the device or a bit narrower.

Pall (1) 4.512

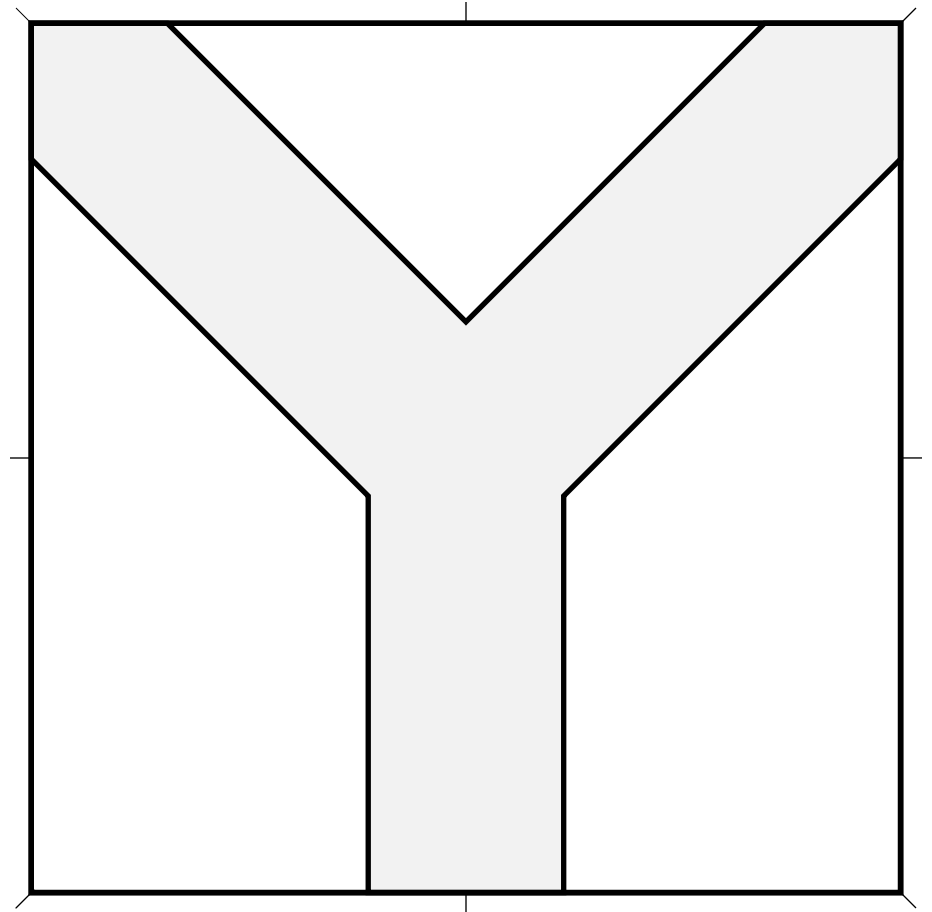
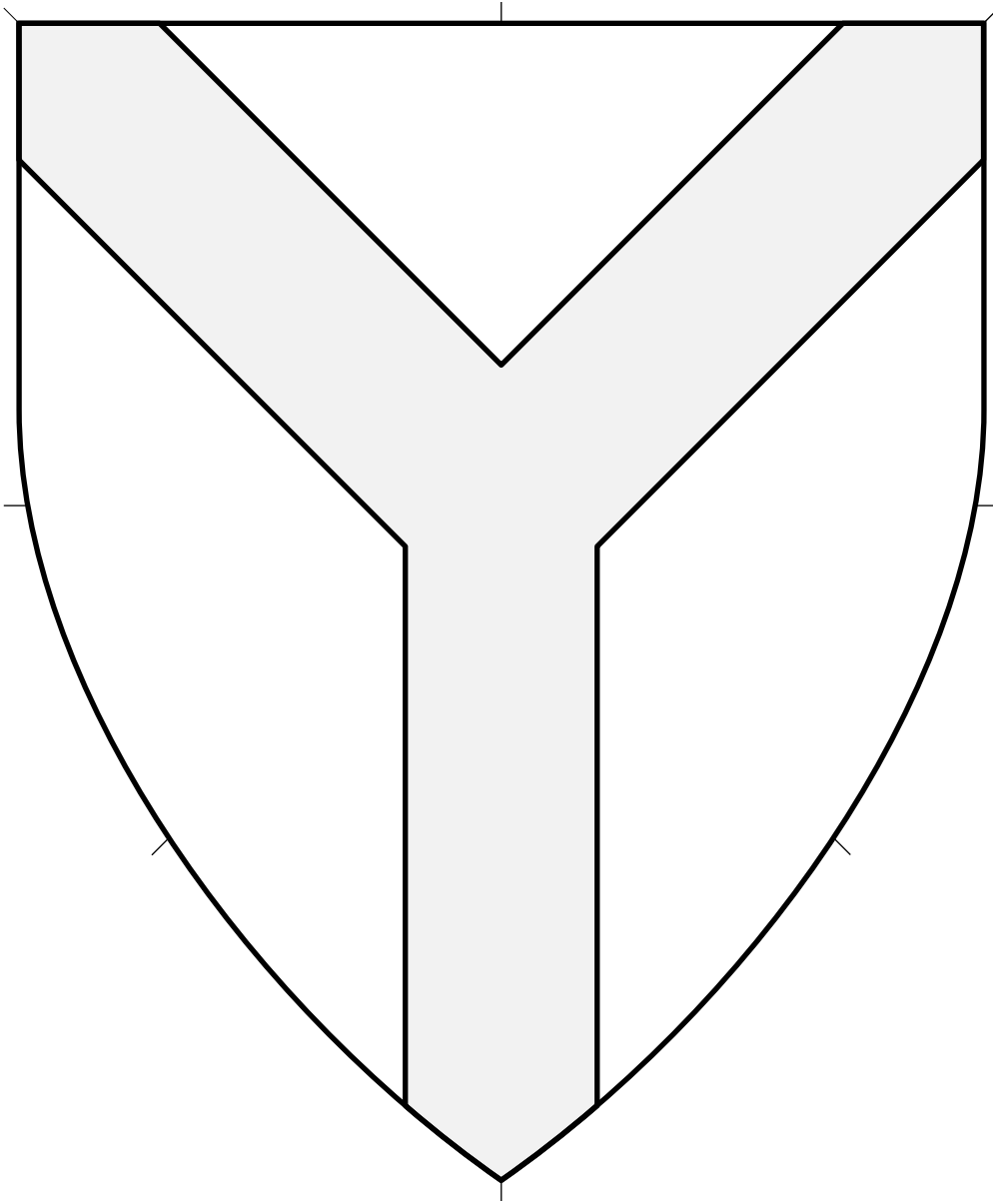

Central ordinary. The width of each arm is typically a third of the width of the device or a bit narrower.

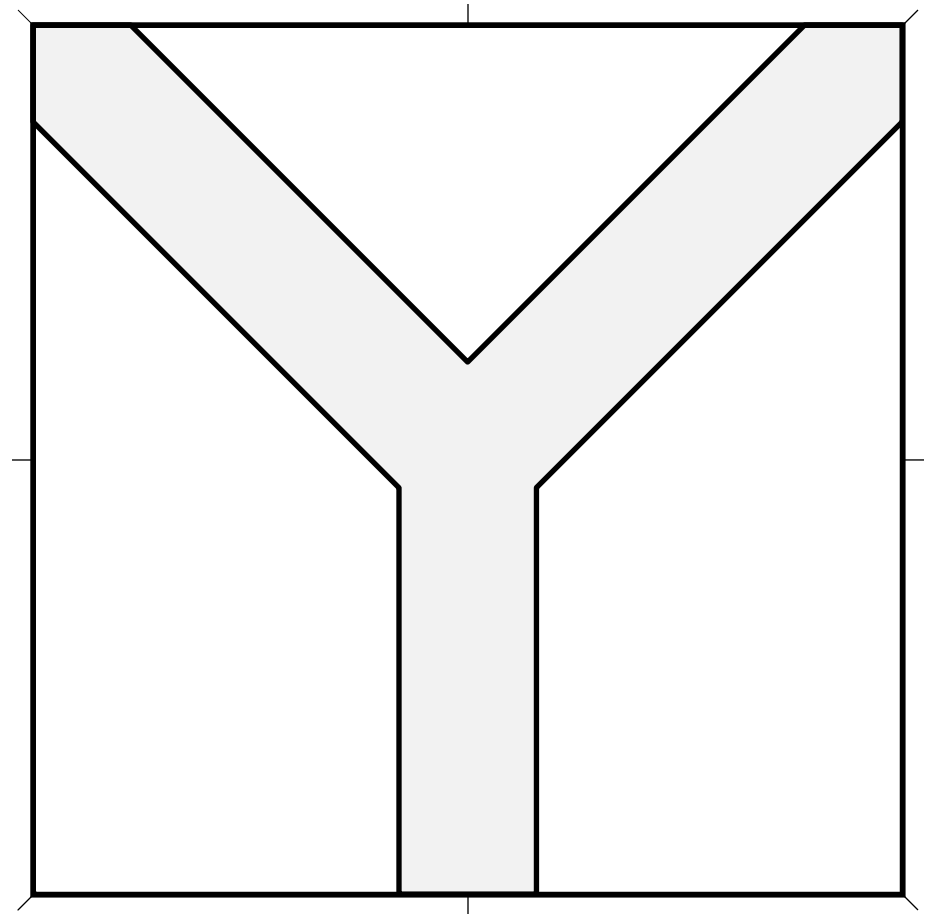
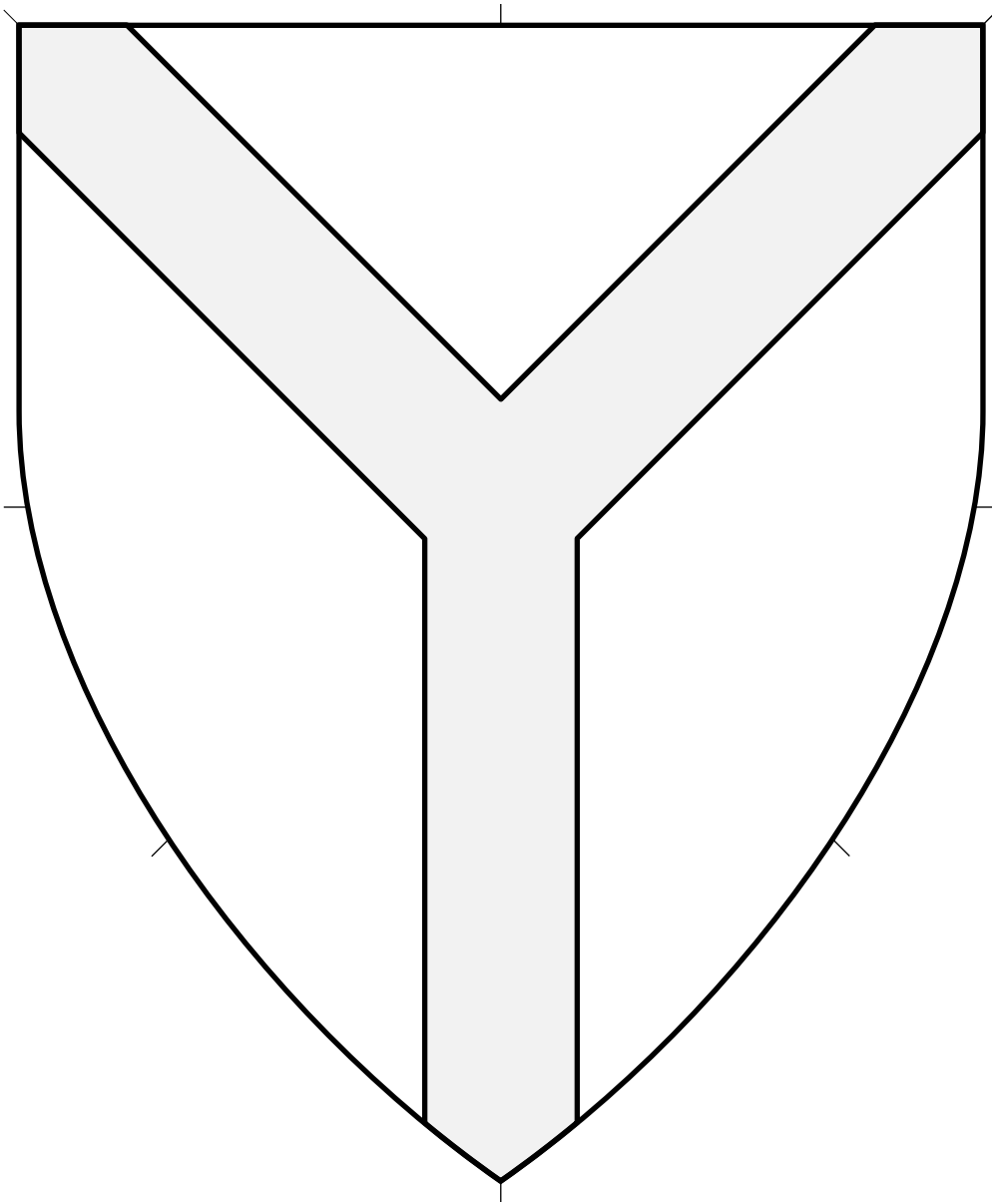

Central ordinary. The width of each arm is typically a third of the width of the device or a bit narrower. A skinny pall like this may be used when surrounded by other charges.

Pall (3) 4.514

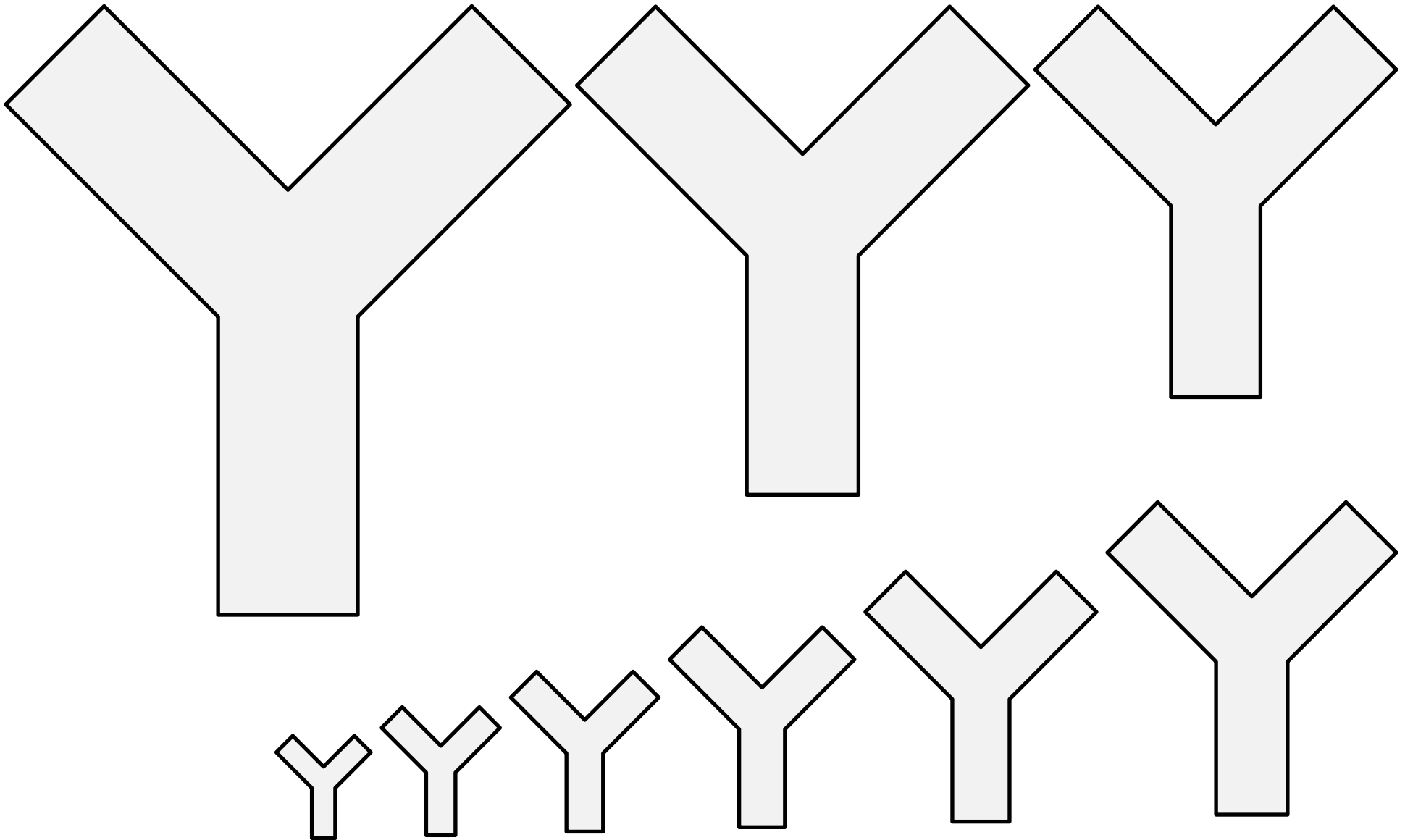

Couped ordinary.

Pall Couped • 4.515

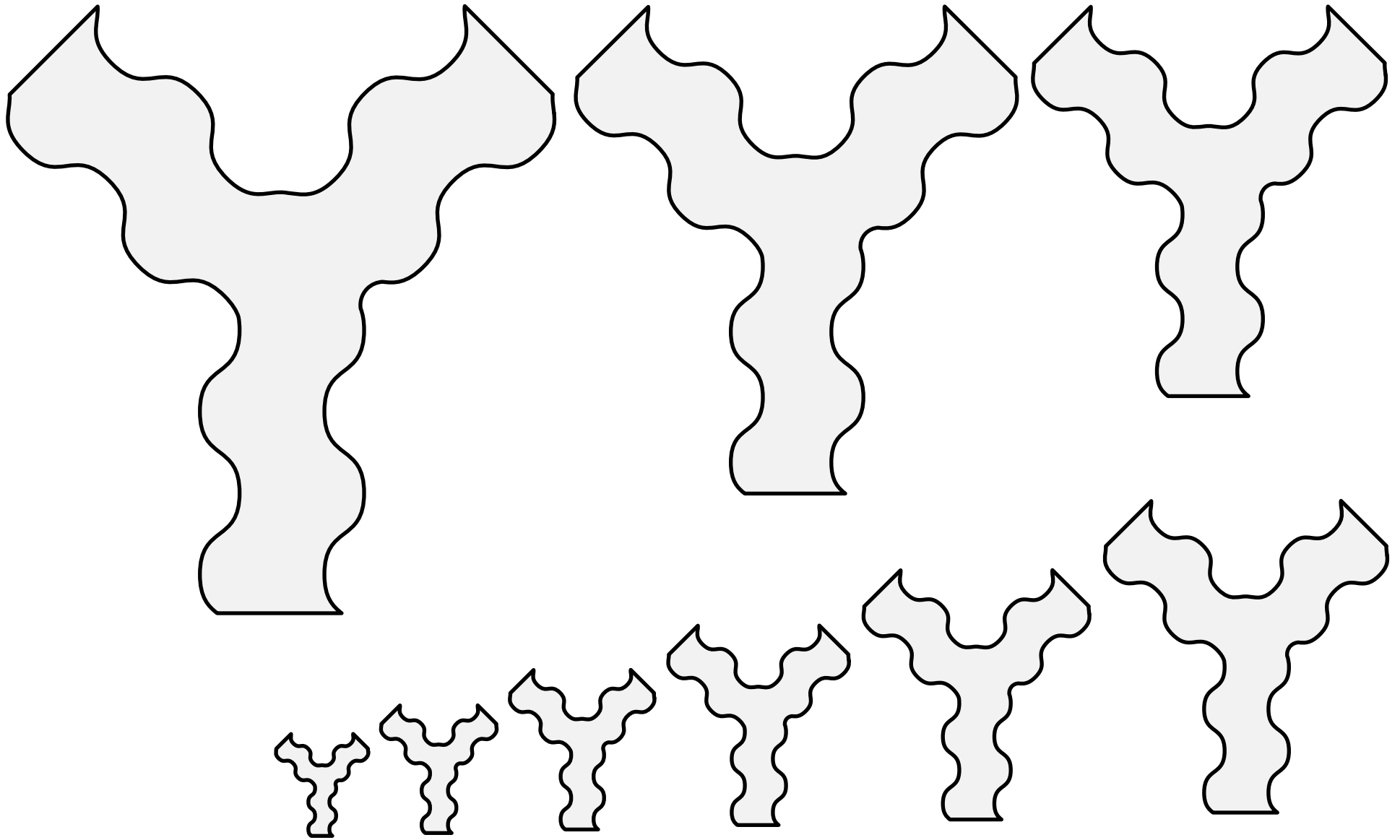

Couped ordinary.

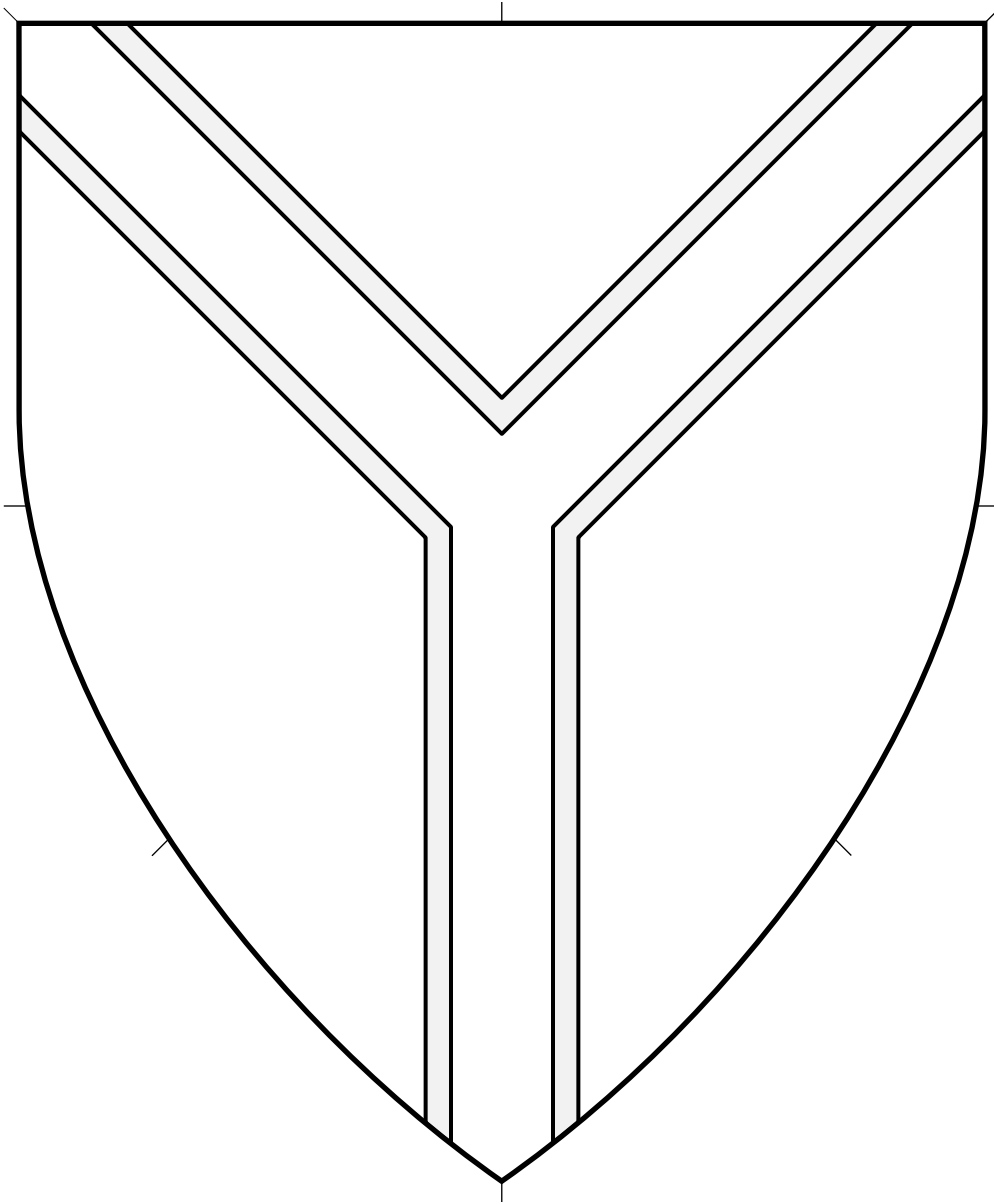

Central ordinary.

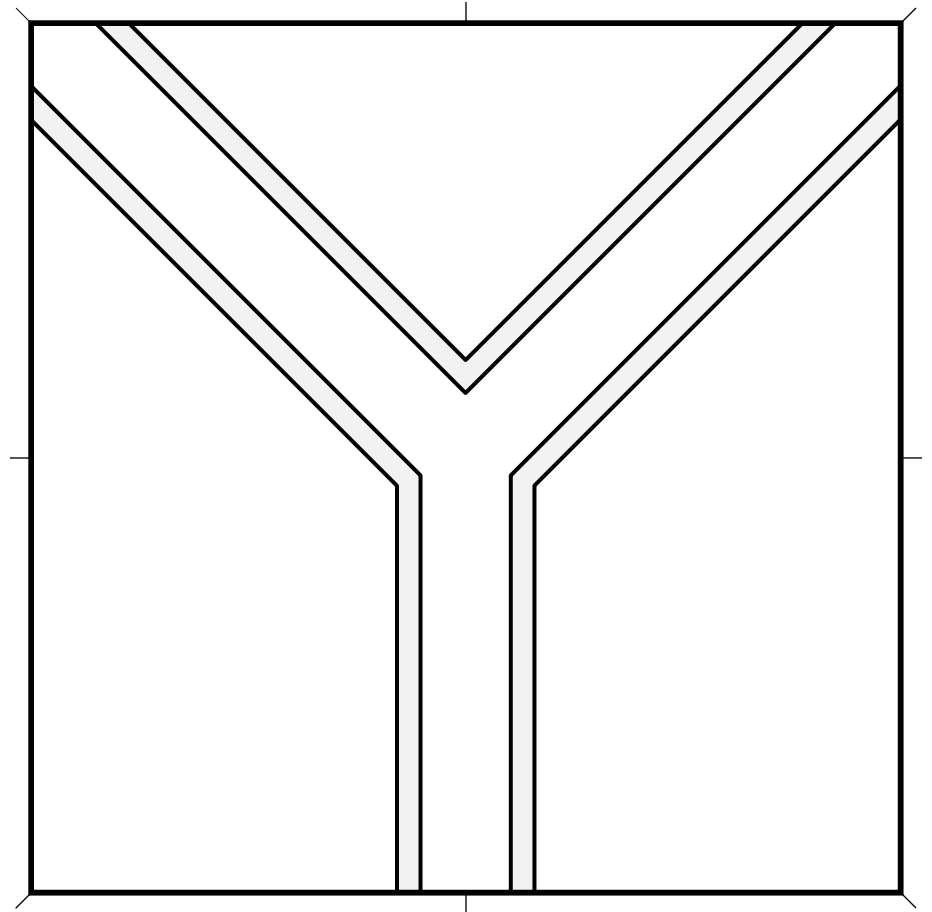

Pall Voided 4.517

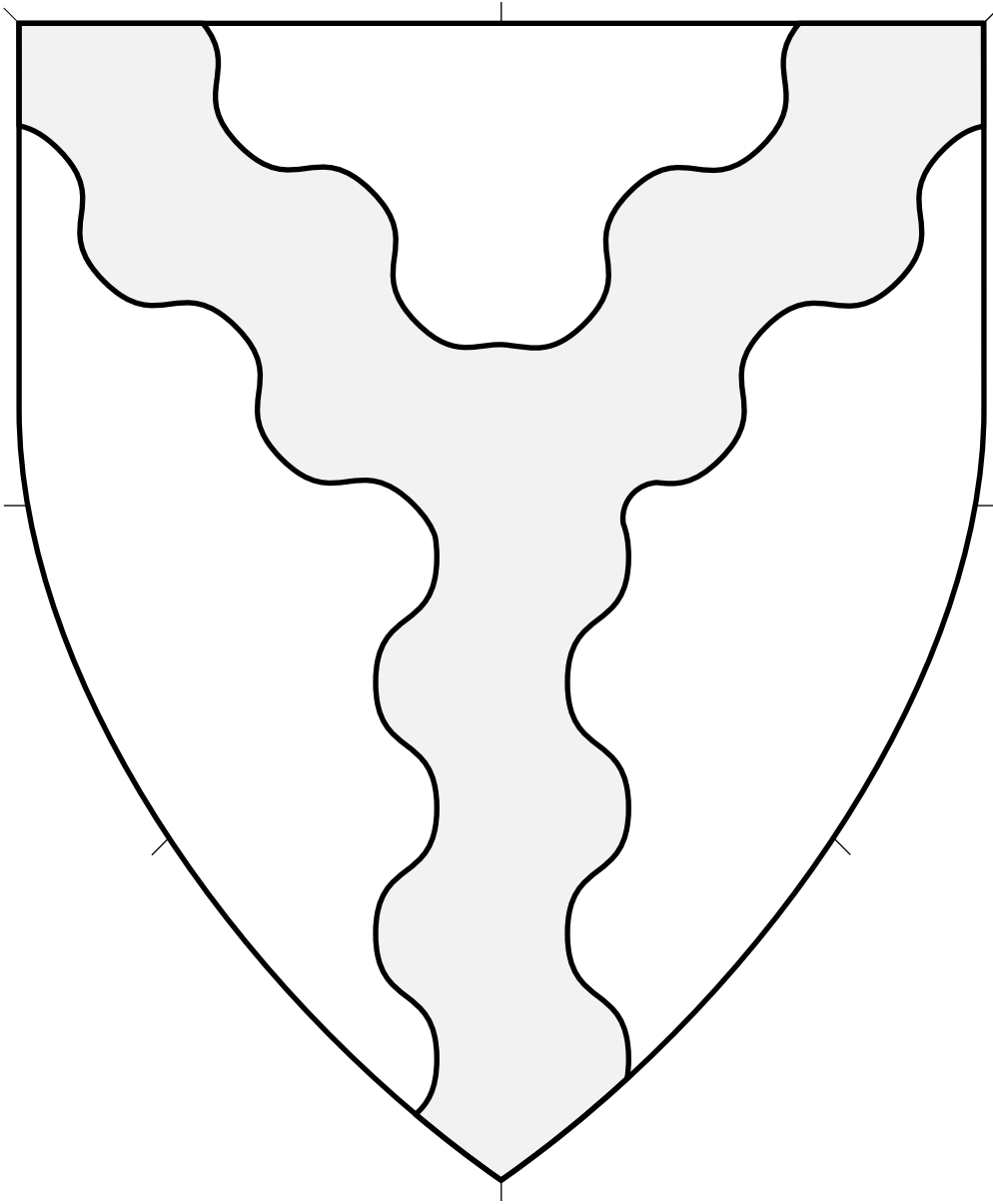

Central ordinary.

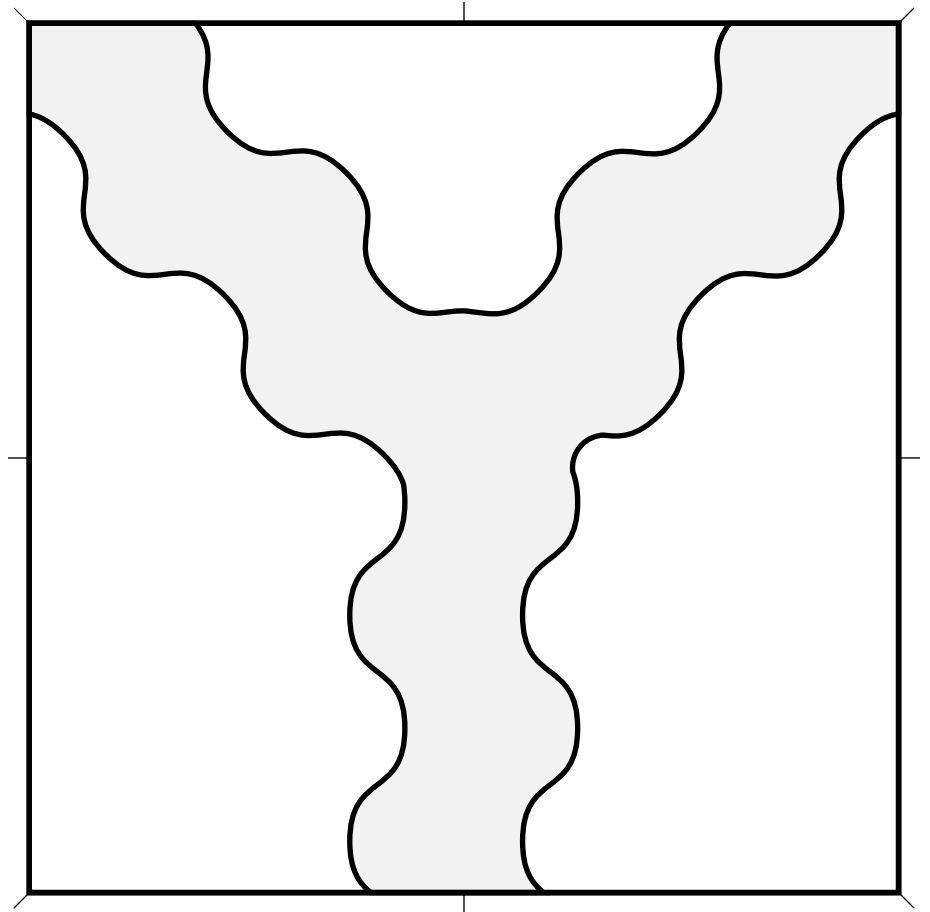

Pall Wavy (1) 4.518

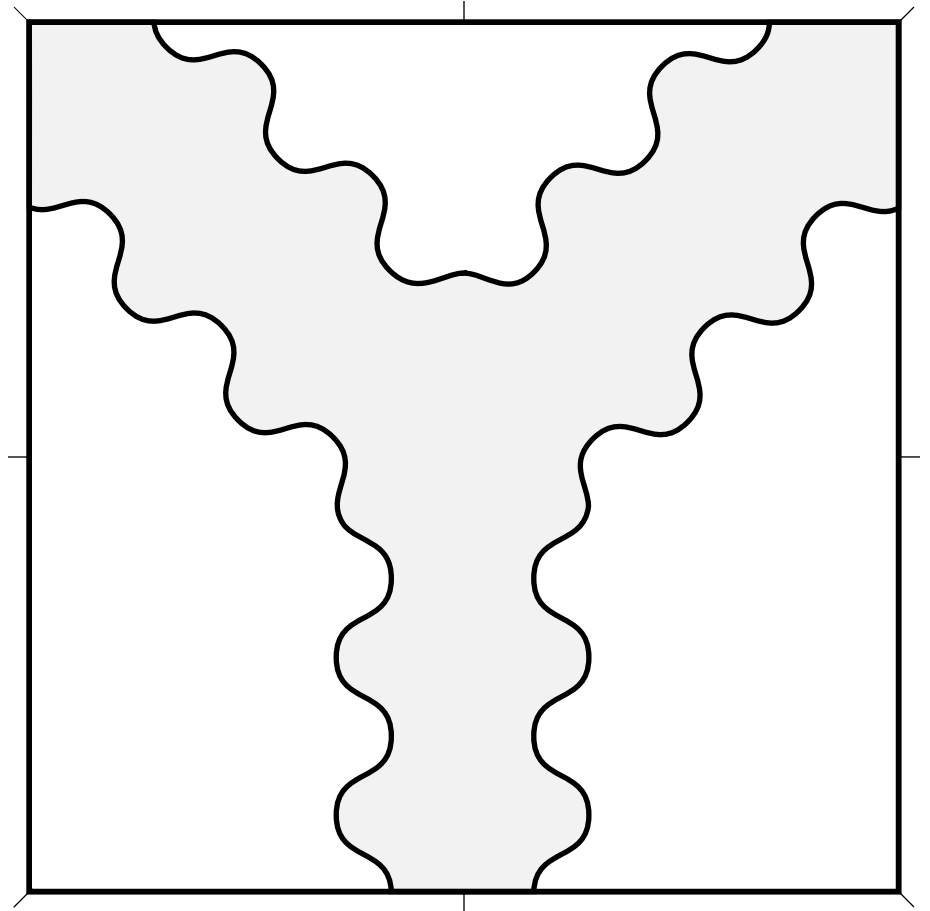
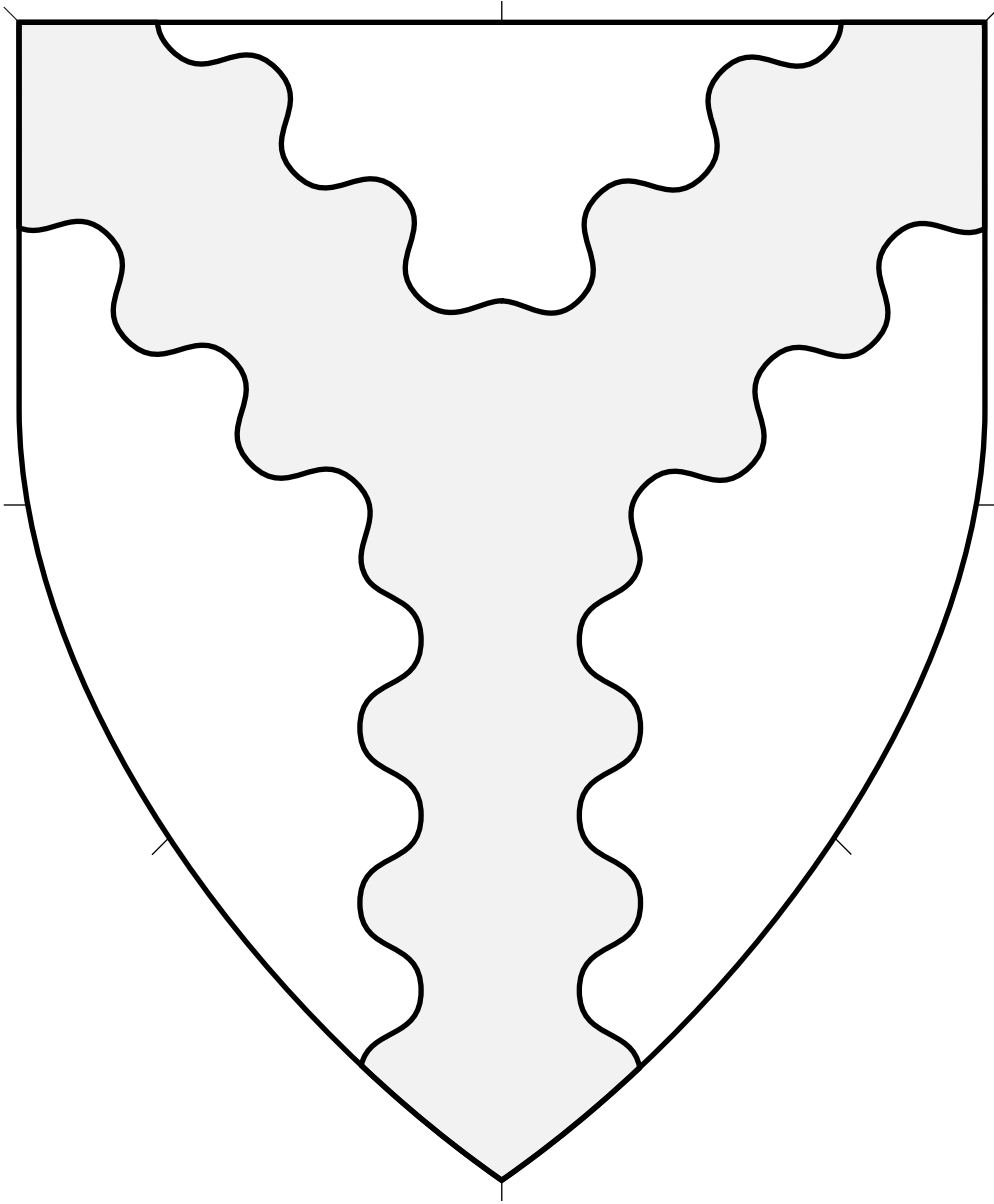

Central ordinary.

Pall Wavy (2) • 4.519

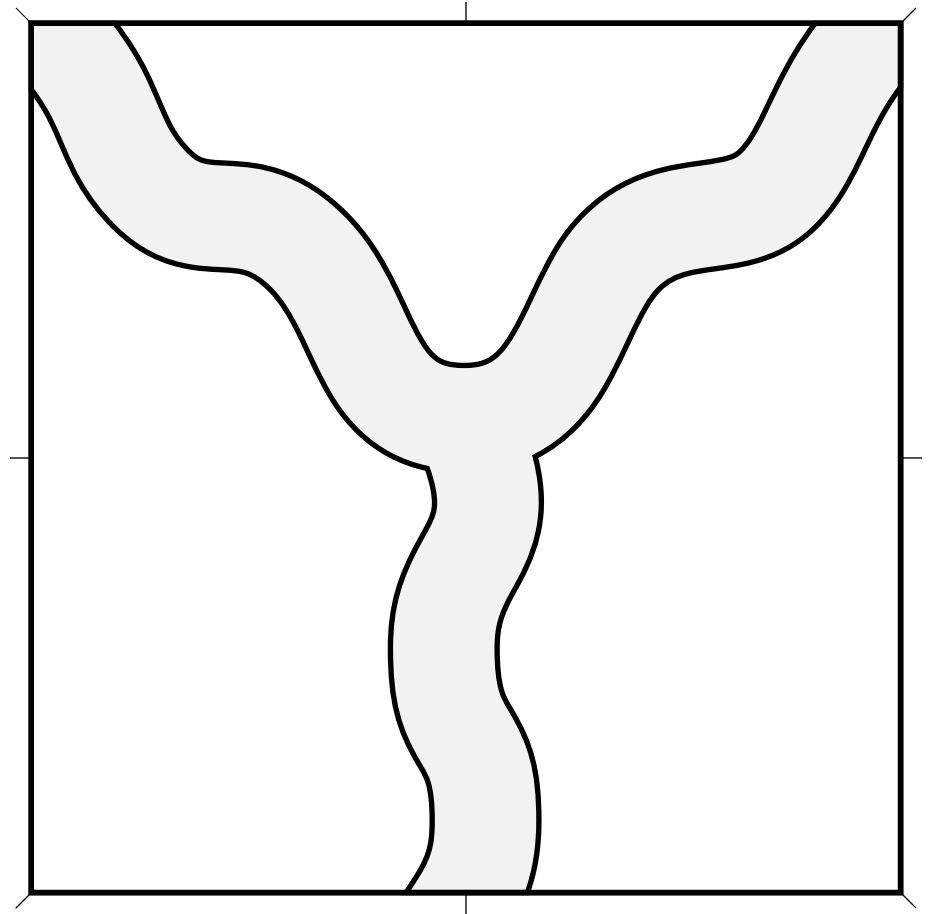
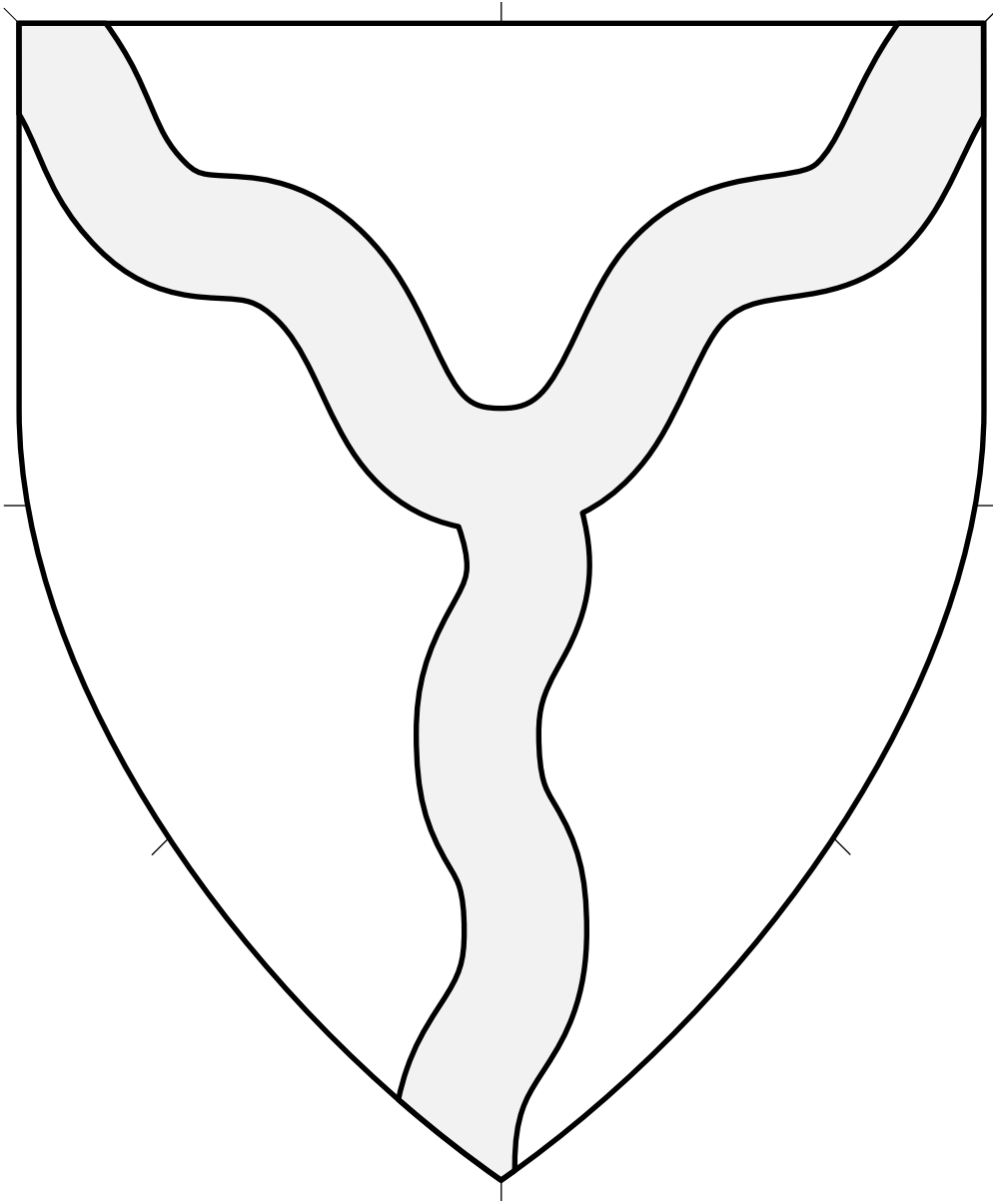

Central ordinary.

Pall Wavy (3) 4.520

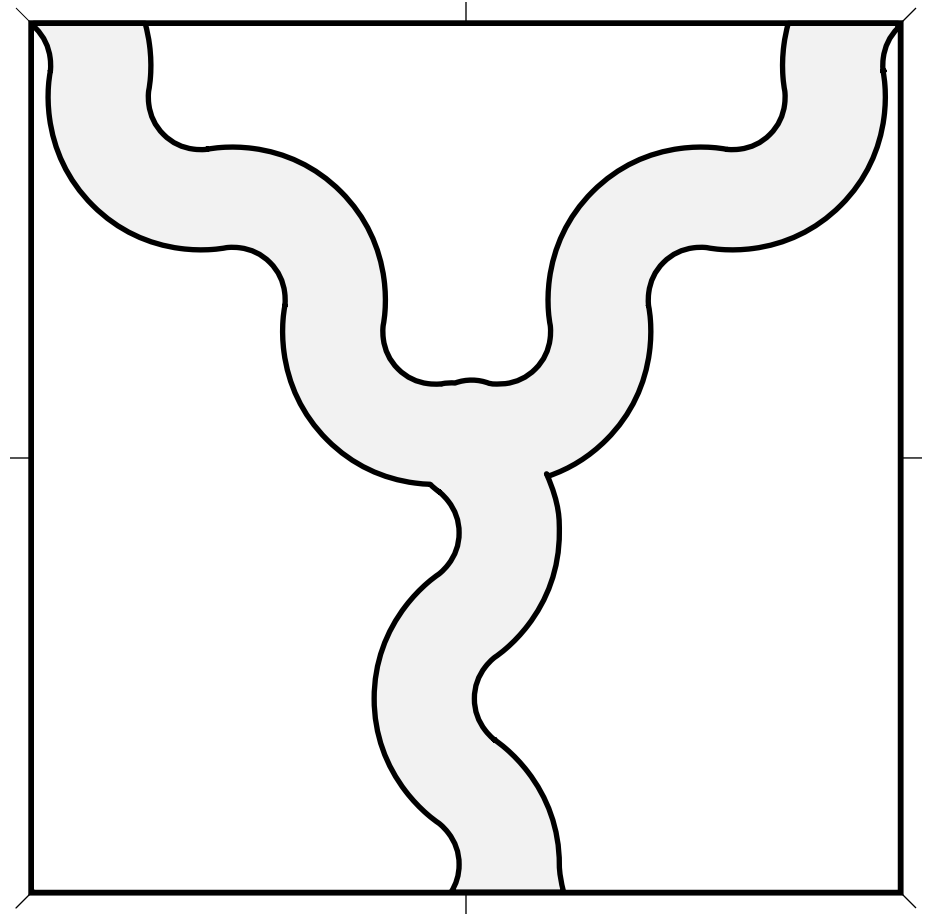
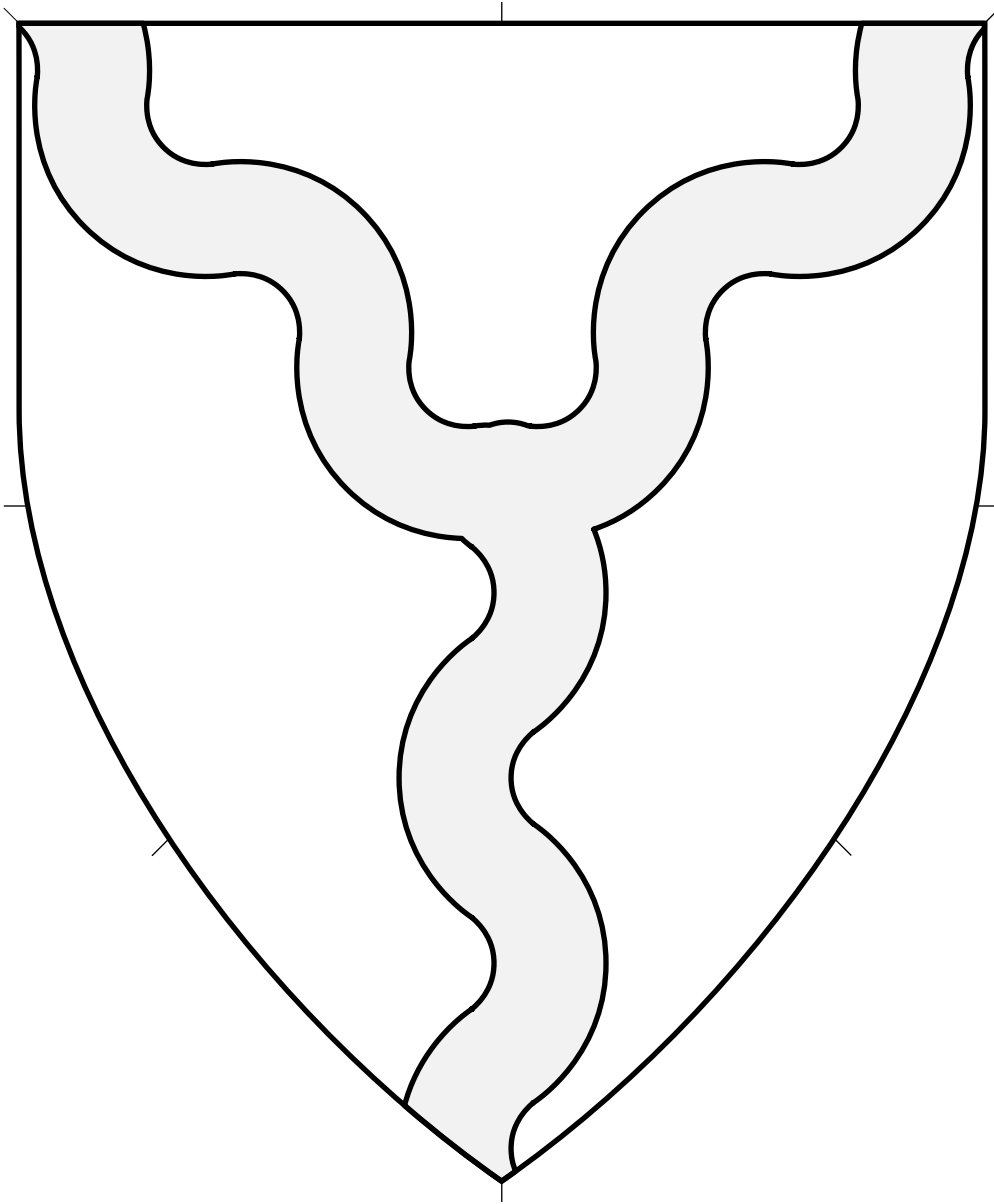

Central ordinary.

Pall Wavy (4) • 4.521

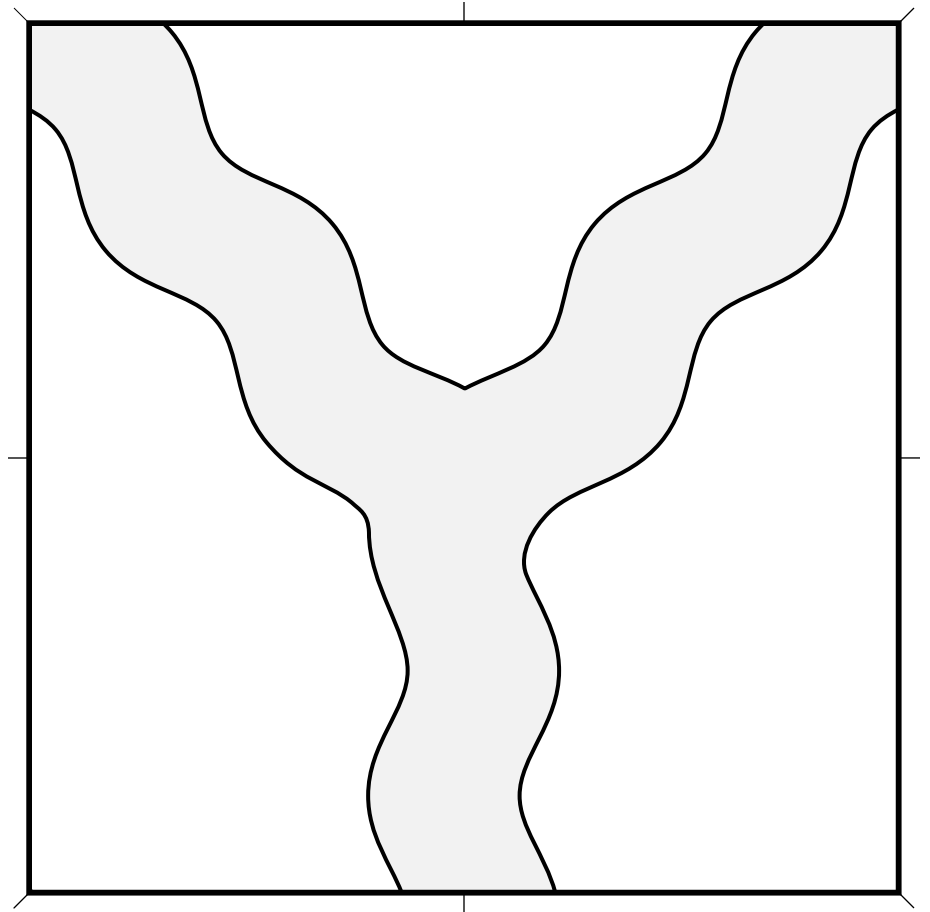
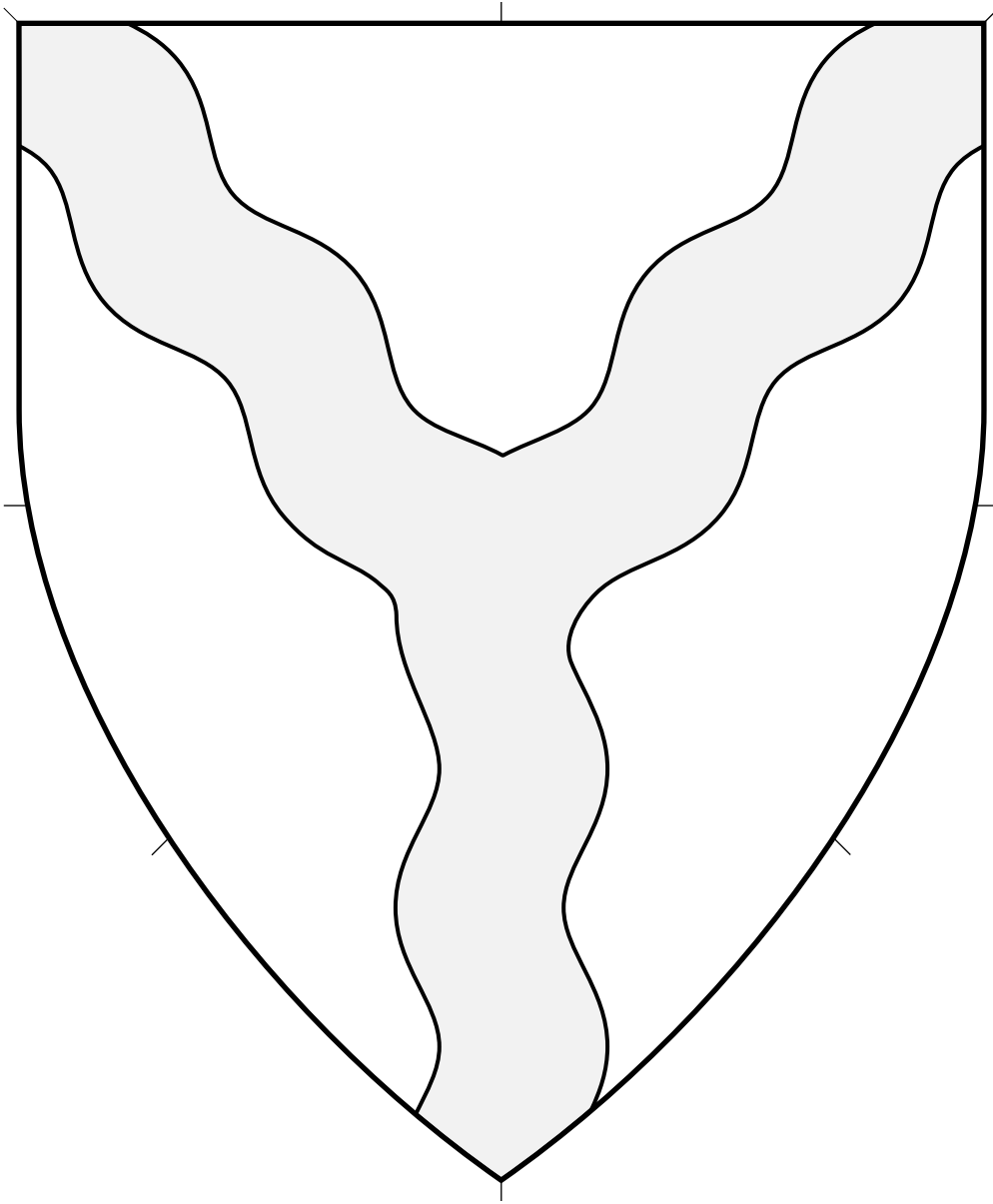

Central ordinary.

Pall Wavy (5) 4.522

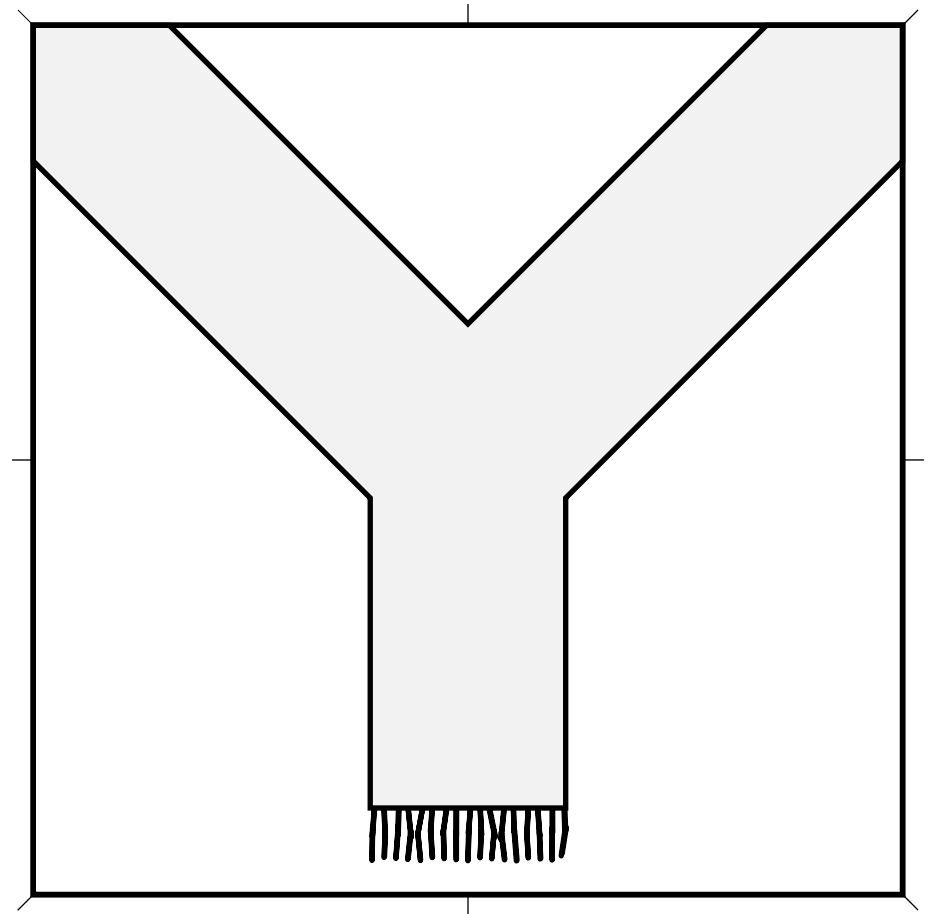
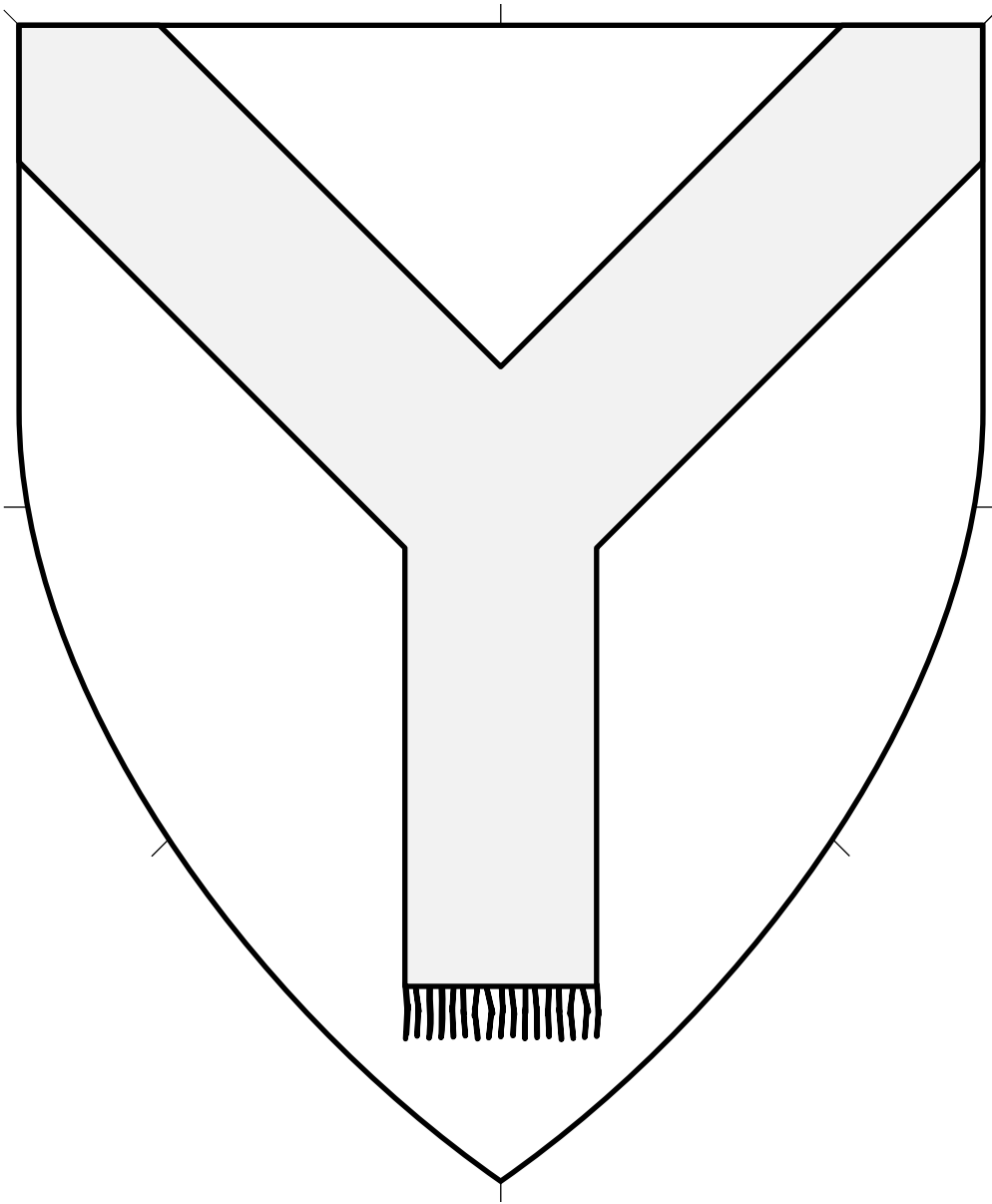

Central ordinary, couped at one end.
The couped end may optionally be decorated or fringed, as it is here.

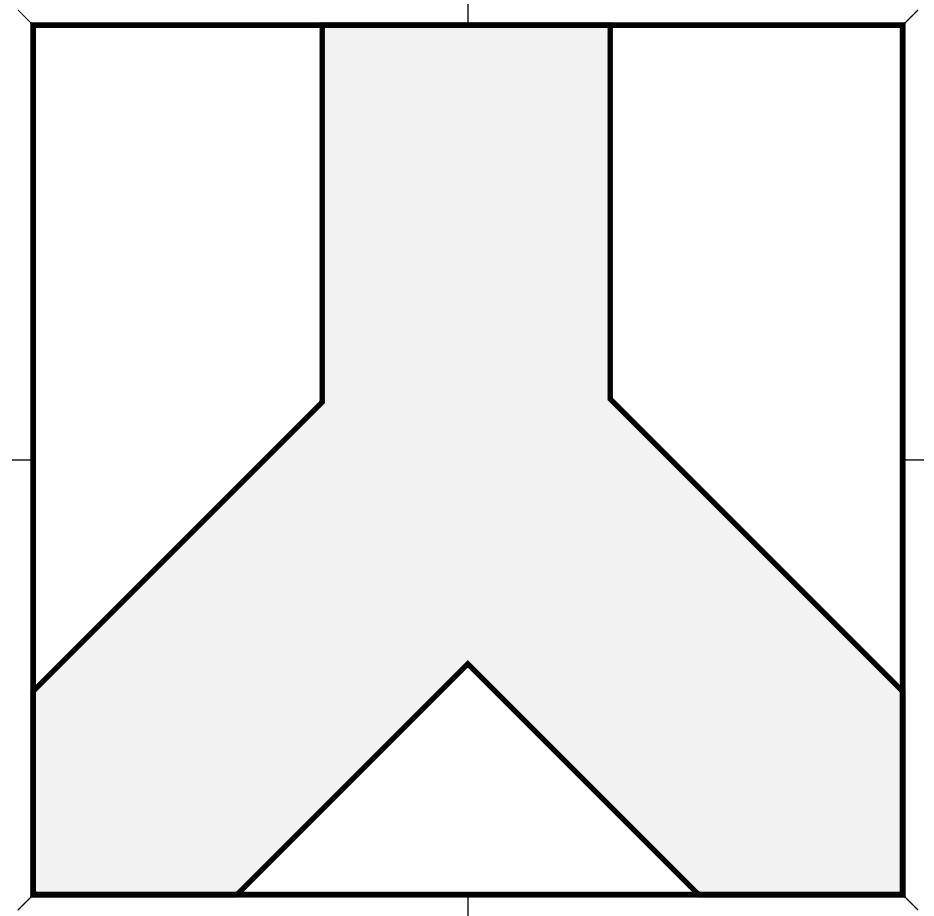
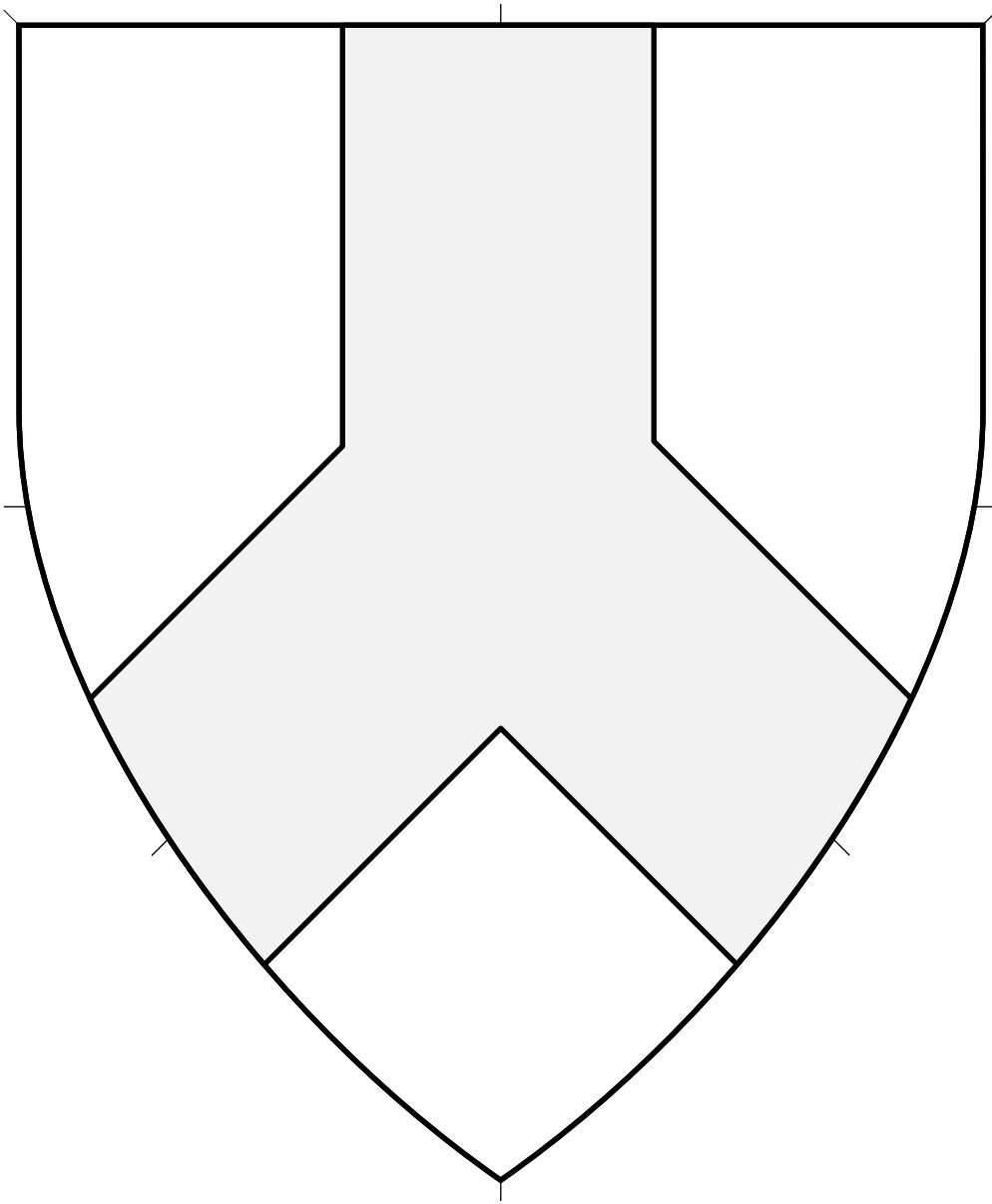

Central ordinary. The width of each arm is typically a third of the width of the device or a bit narrower.

Pall Inverted (1) • 4.524

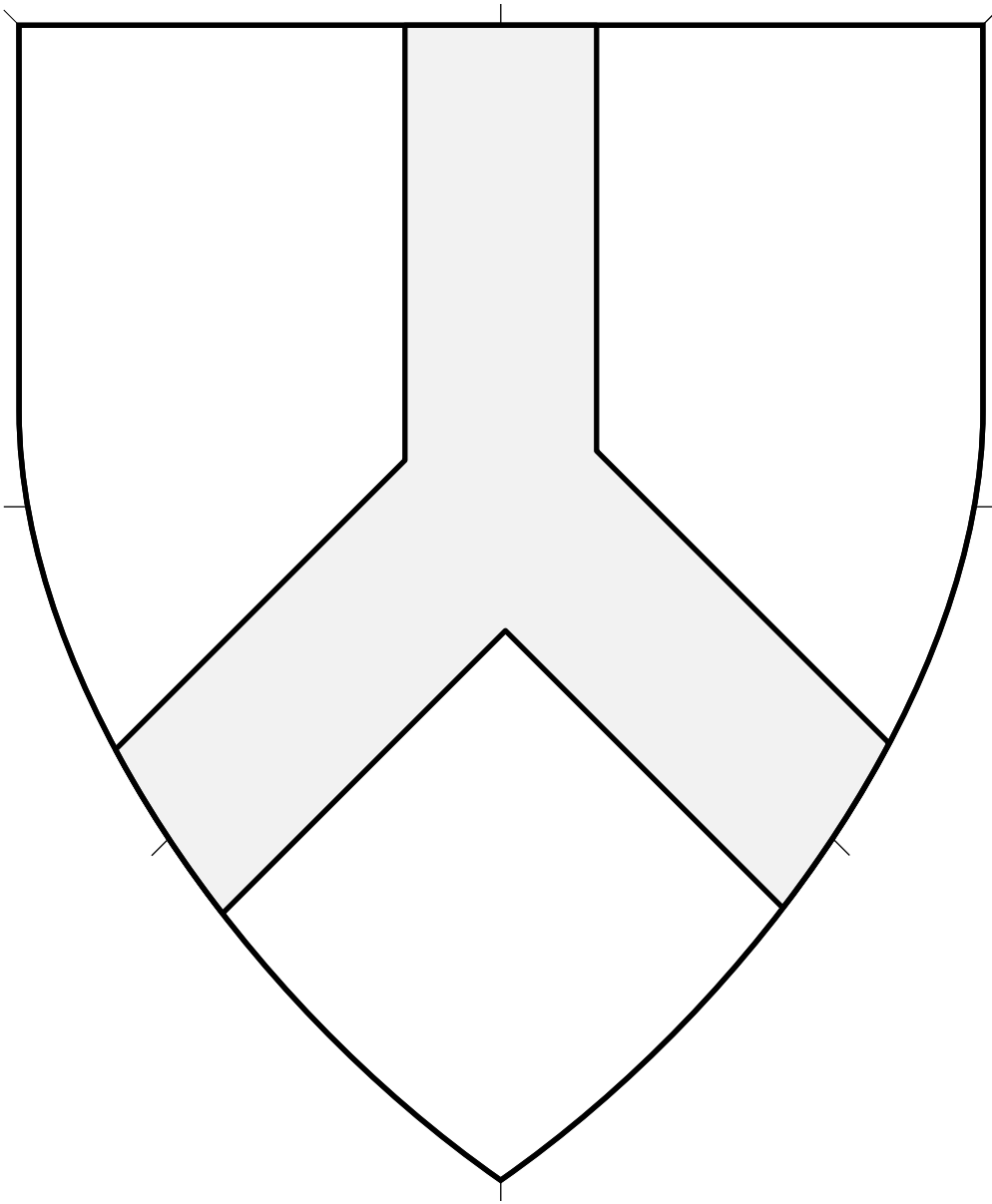

Central ordinary. The width of each arm is typically a third of the width of the device or a bit narrower.

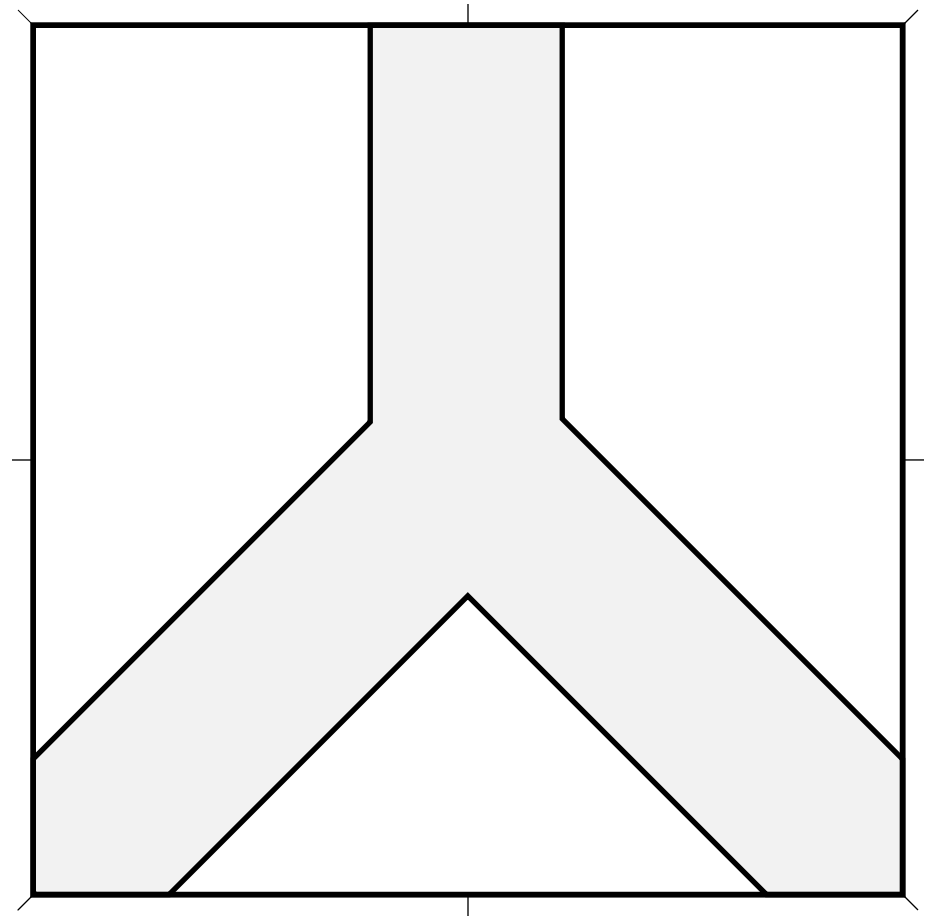

Pall Inverted (2) 4.525

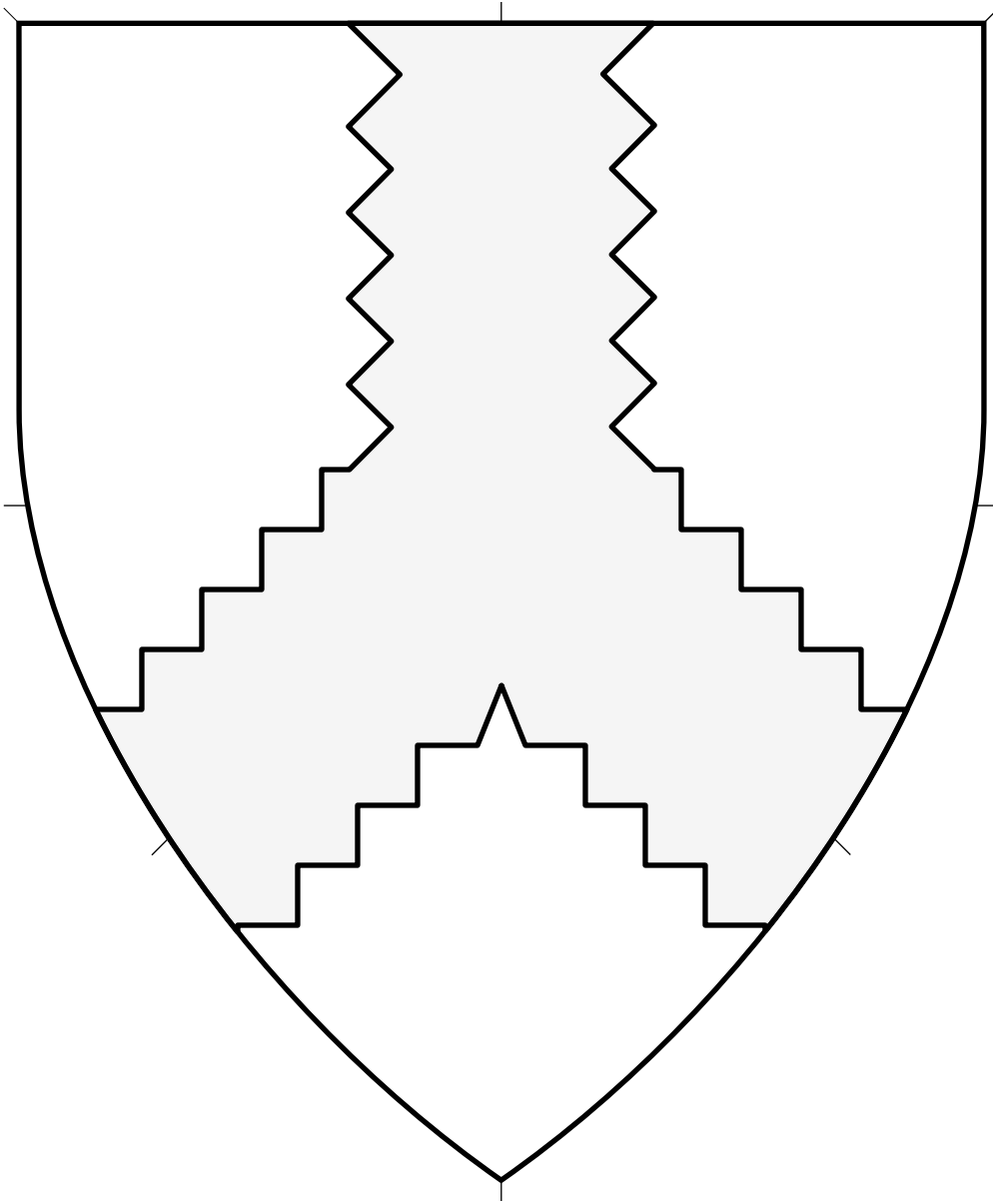

Central ordinary.

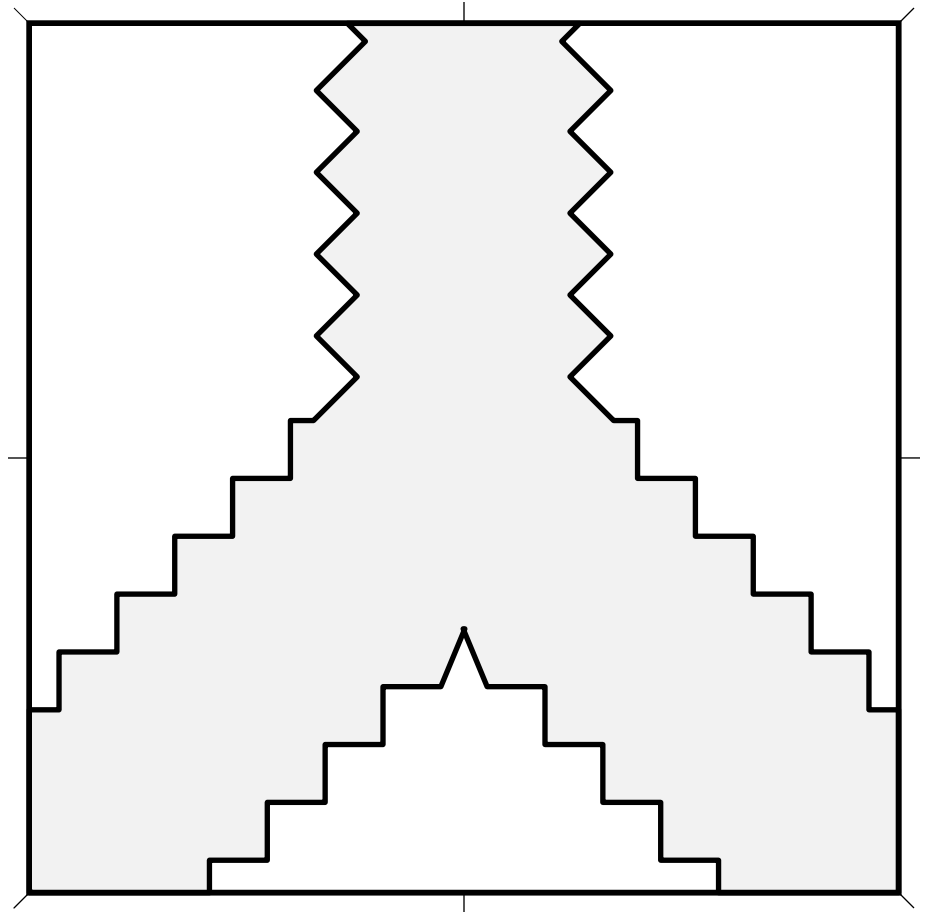

Pall Inverted Indented 4.526

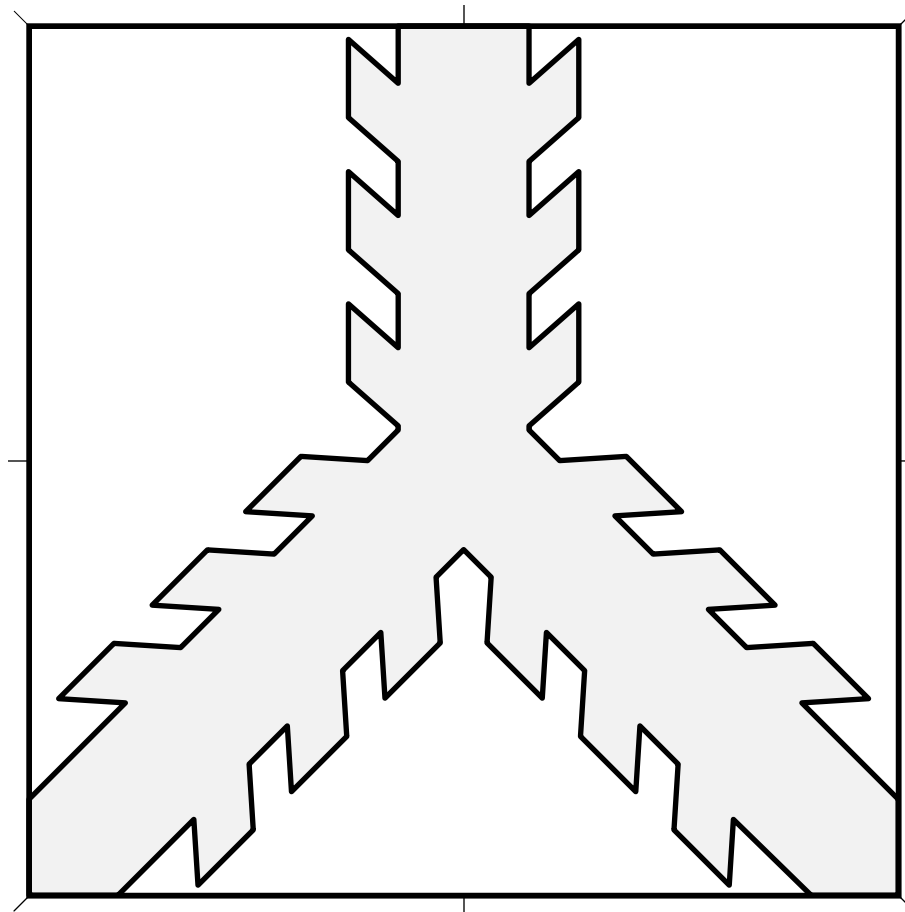
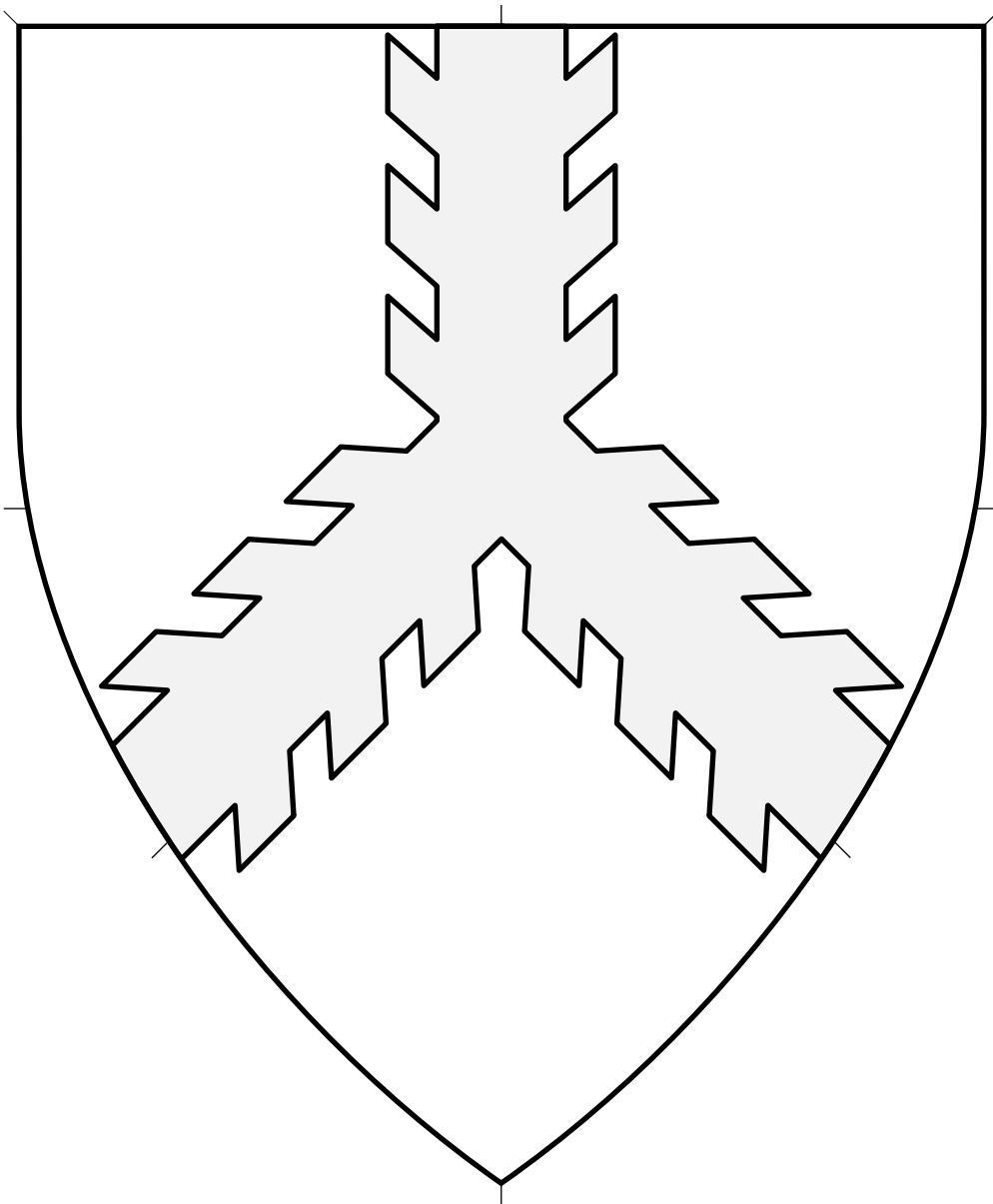

Central ordinary.

Source: Viking Answer Lady SVG Images For Heraldry.
Artist: Gunnvôr silfrahárr. Adapted by Mathghamhain Ua Ruadháin.

Pall Inverted Raguly 4.527

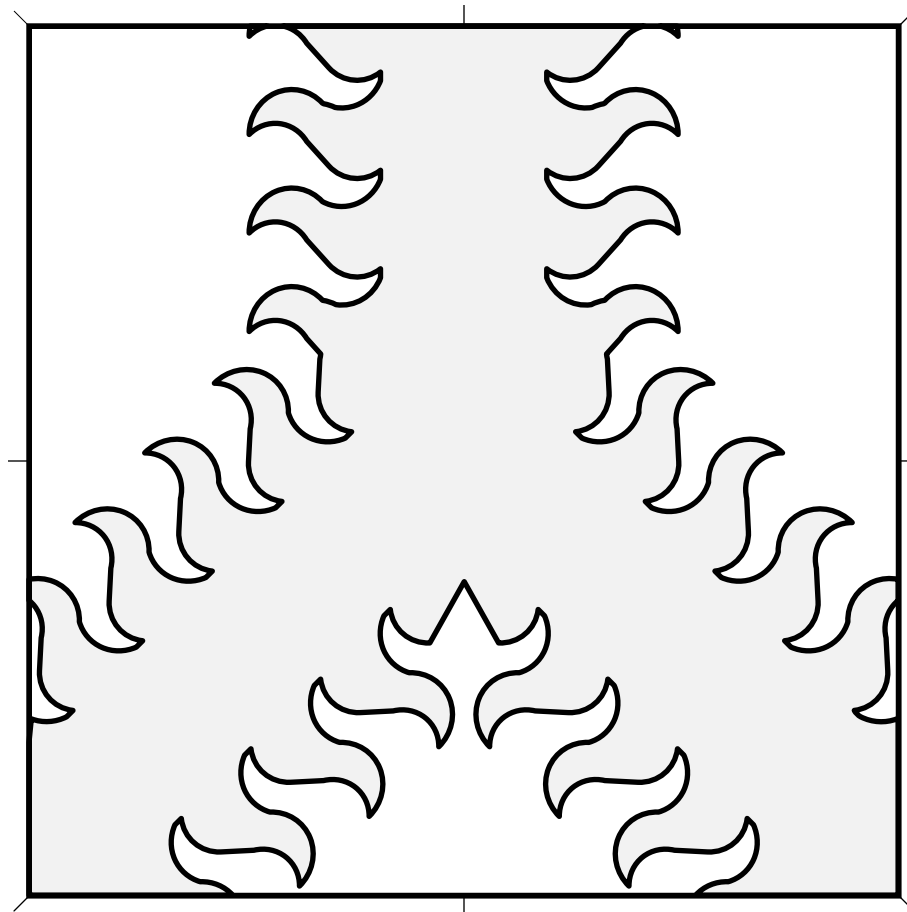
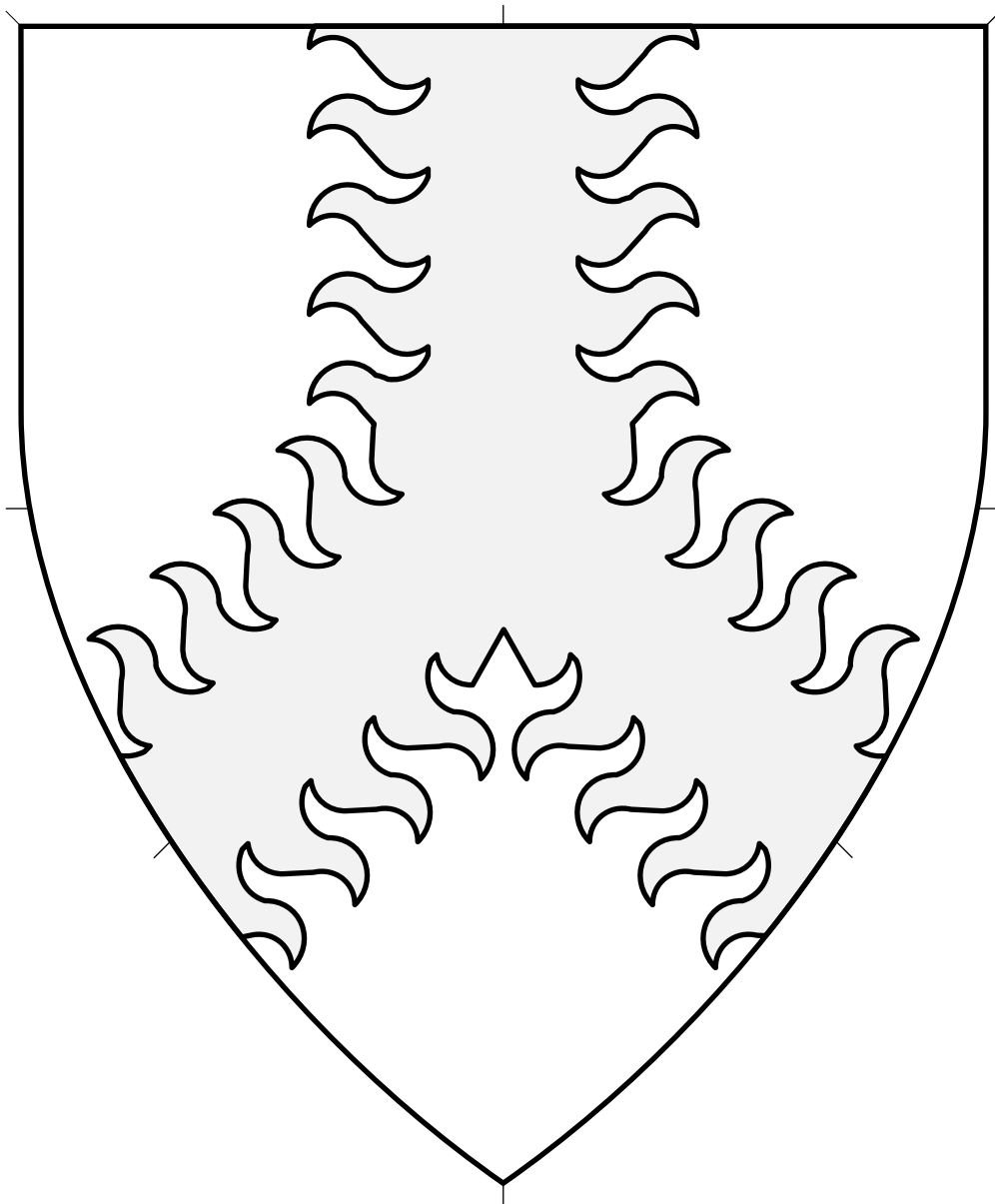

Central ordinary.

Source: Viking Answer Lady SVG Images For Heraldry.
Artist: Gunnvôr silfrahárr. Adapted by Mathghamhain Ua Ruadháin.

Pall Inverted Rayonny 4.528

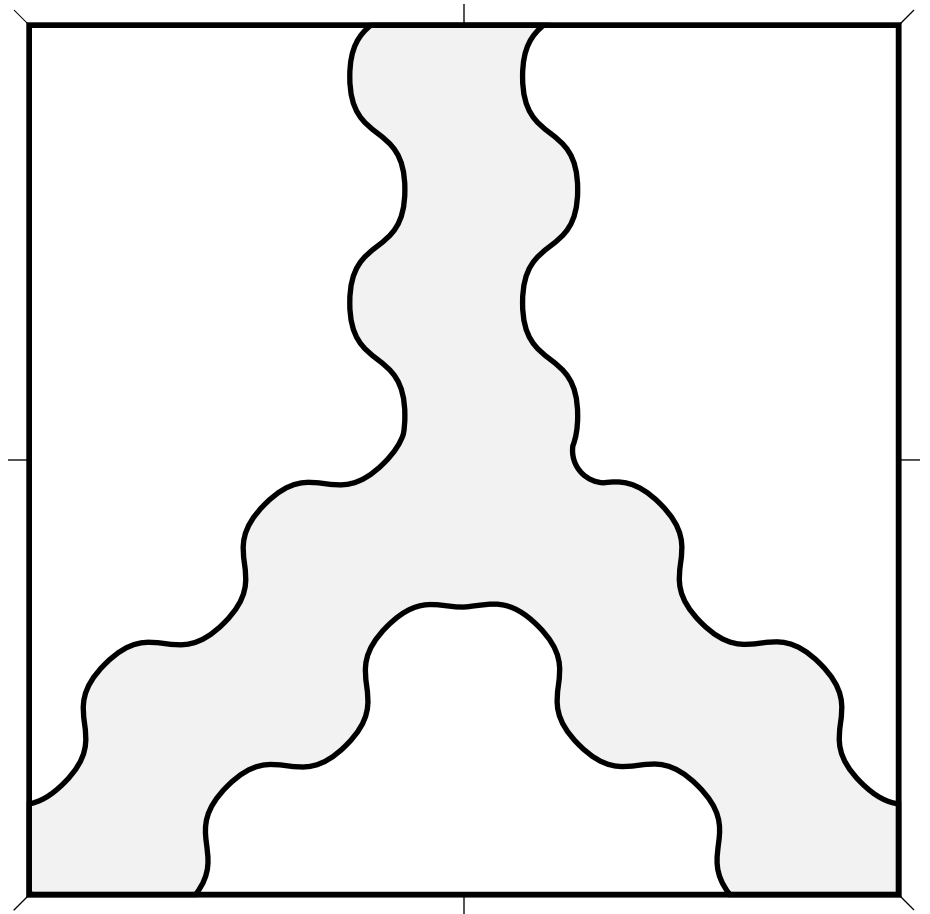
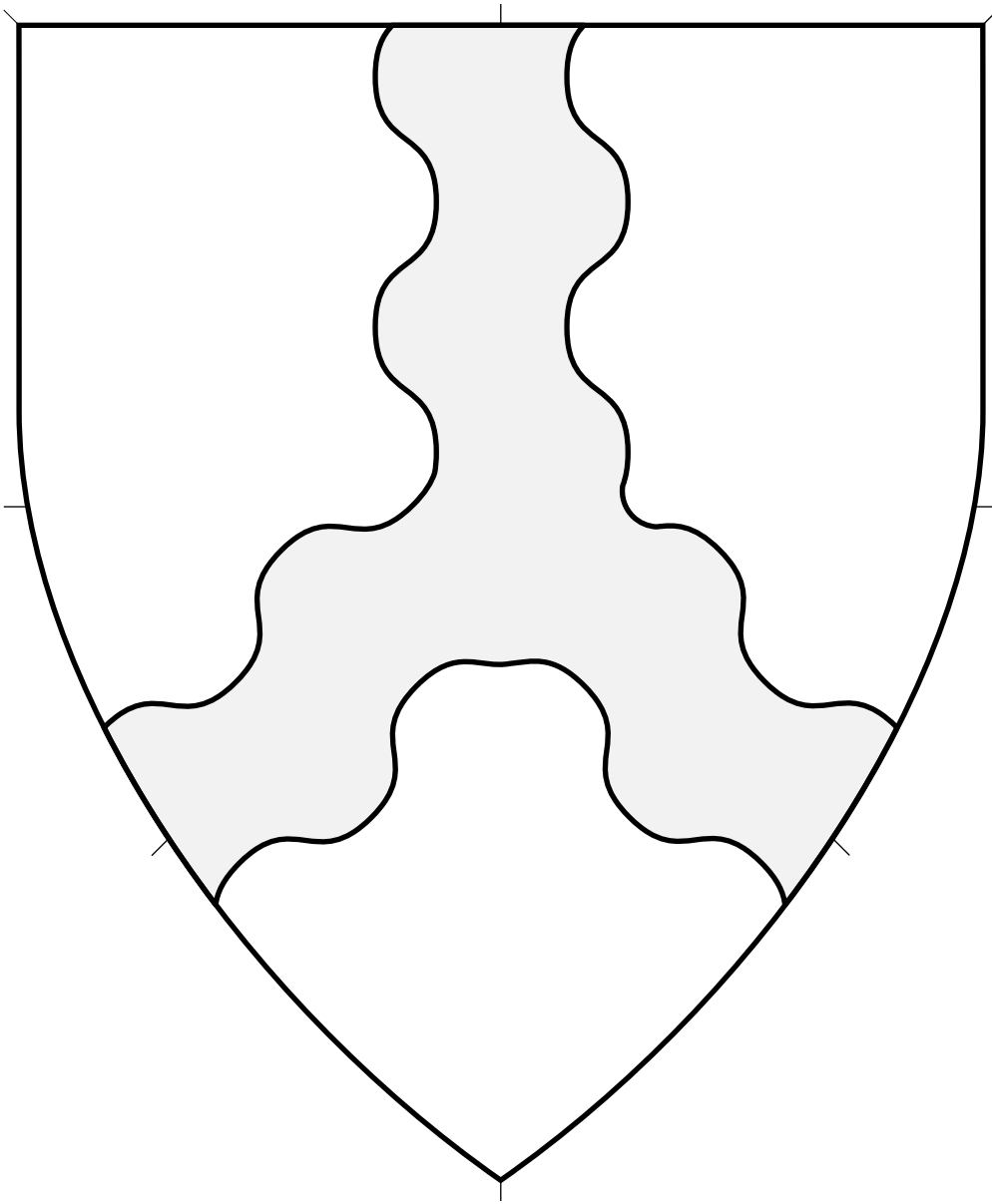

Central ordinary.

Pall Inverted Wavy (1) 4.529

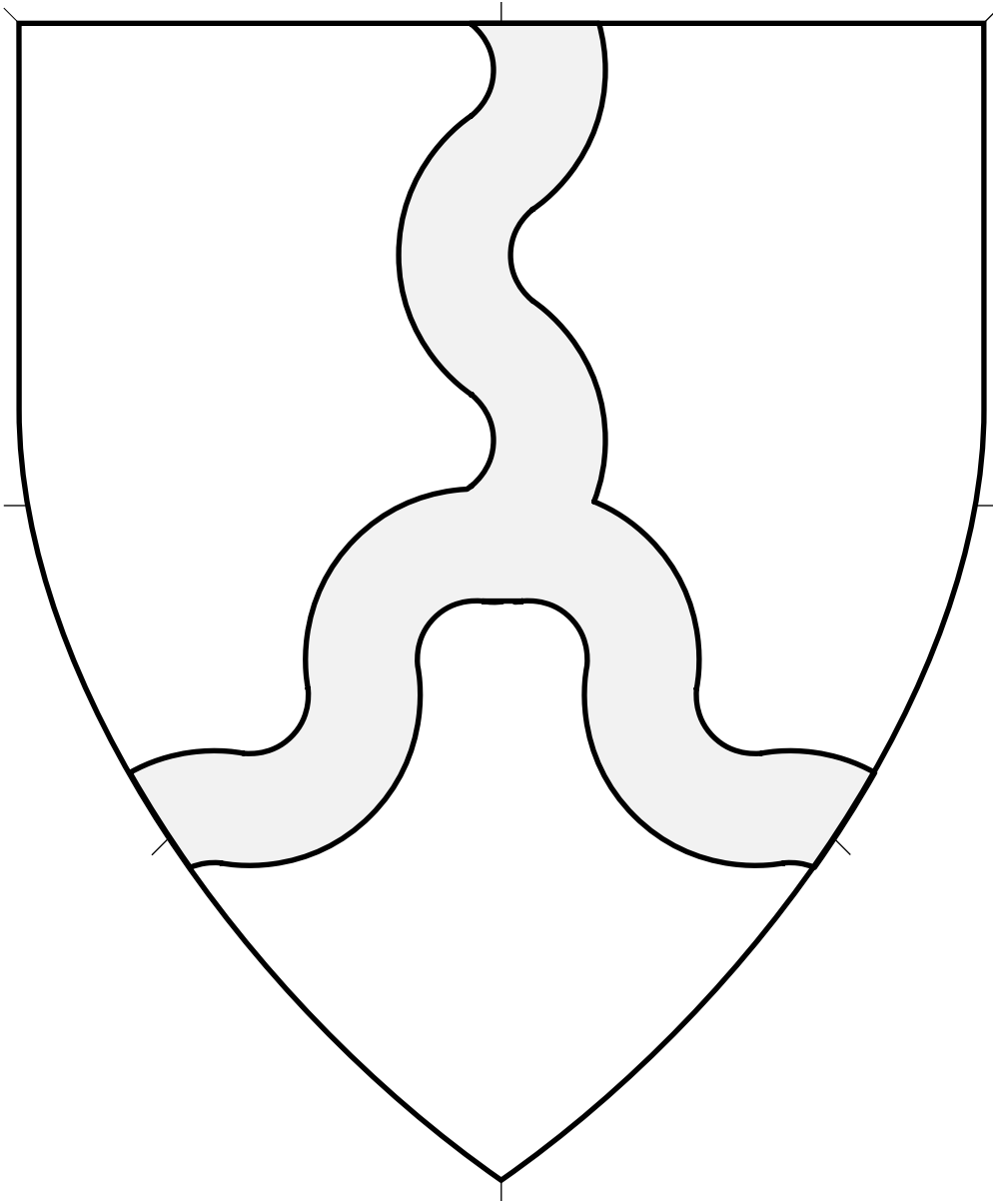

Central ordinary.

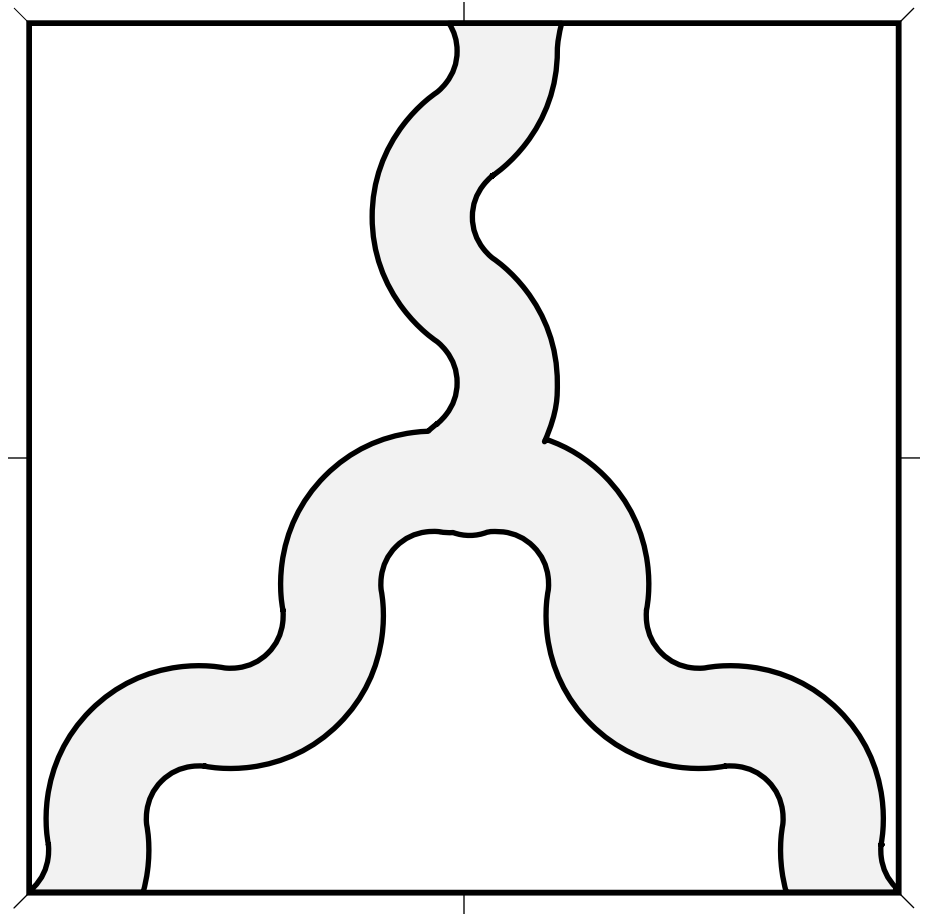

Pall Inverted Wavy (2) 4.530

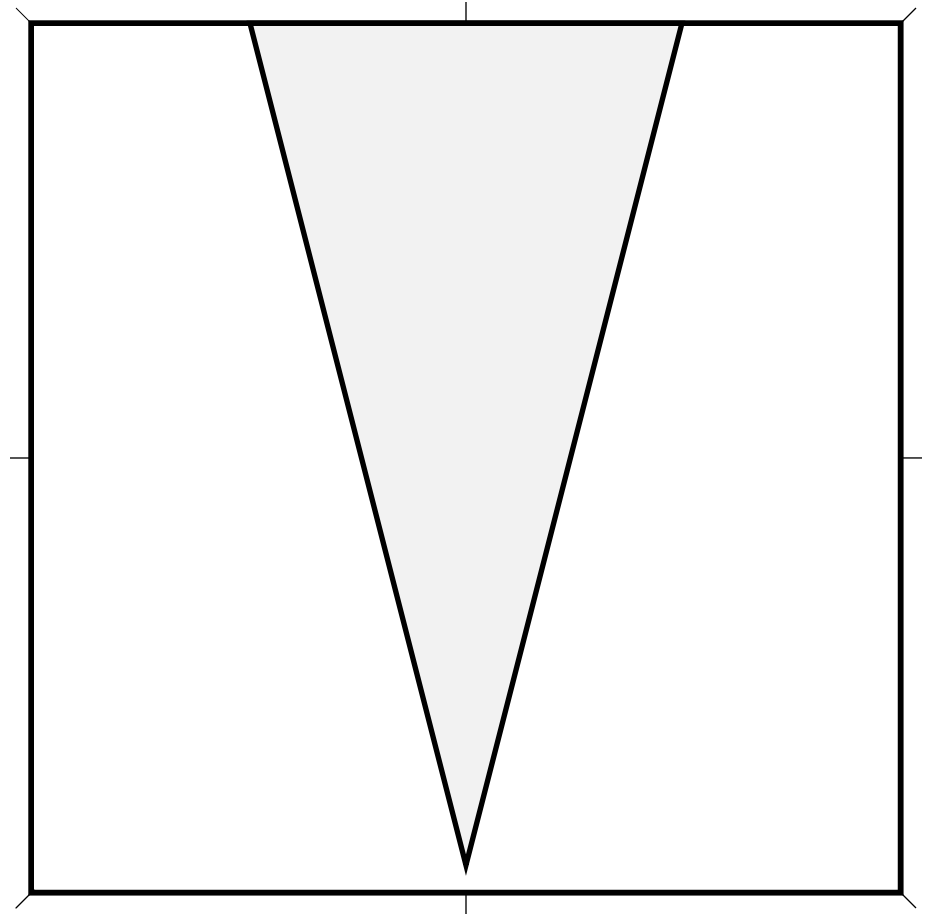
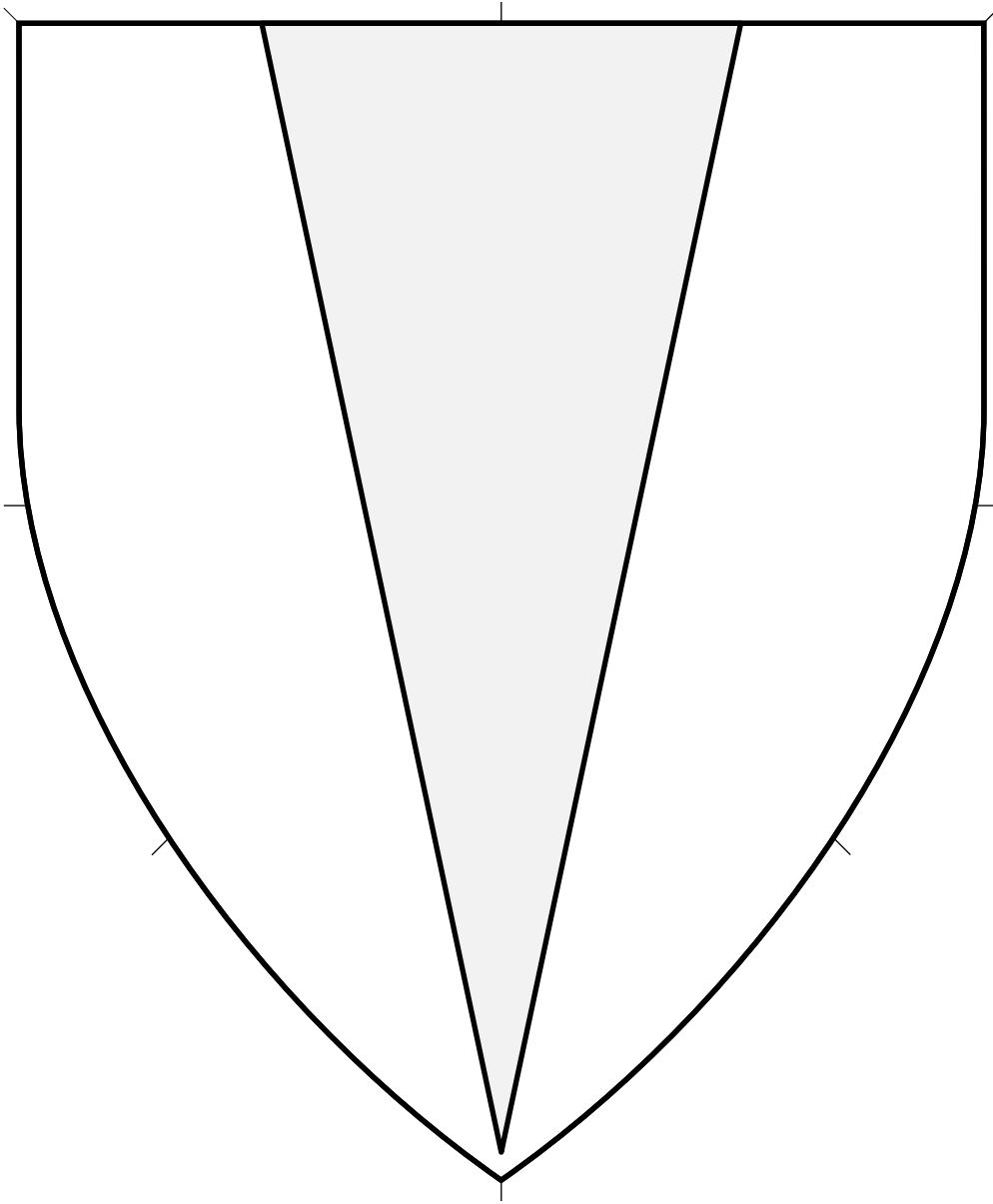

Central ordinary. Width at chief is anywhere from one third to two thirds of the total, or less if there are multiples. May be throughout, reaching the base, or not.

Pile (1) 4.531

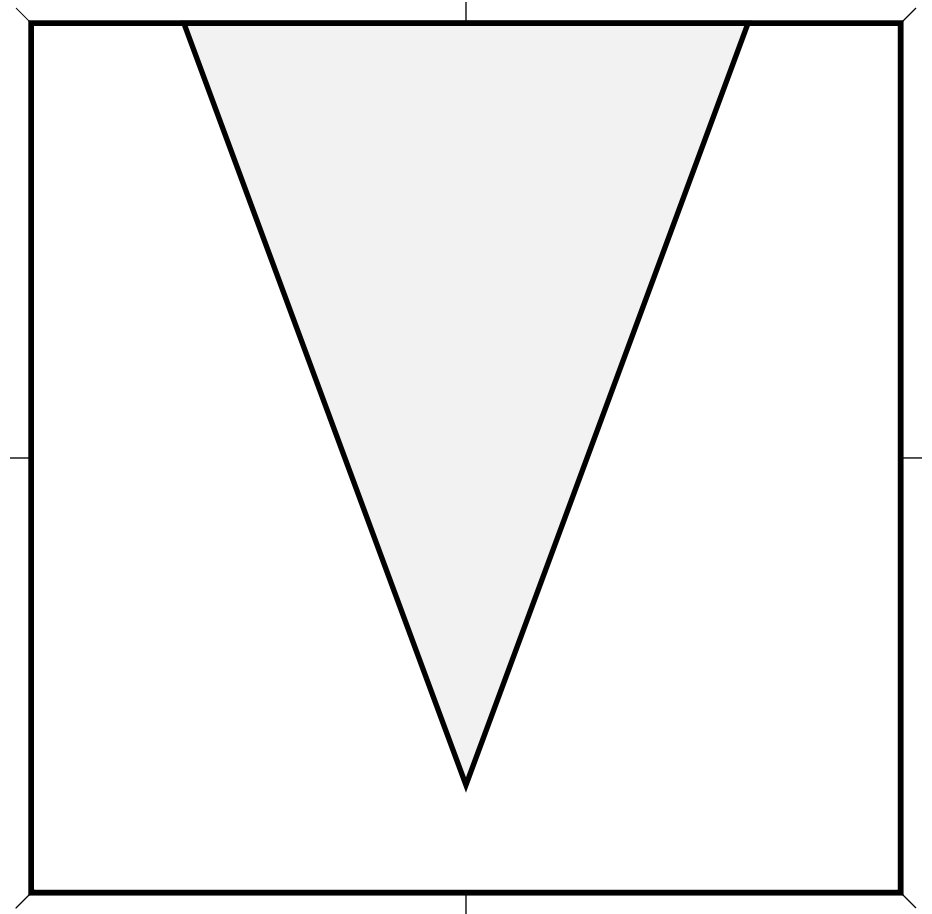
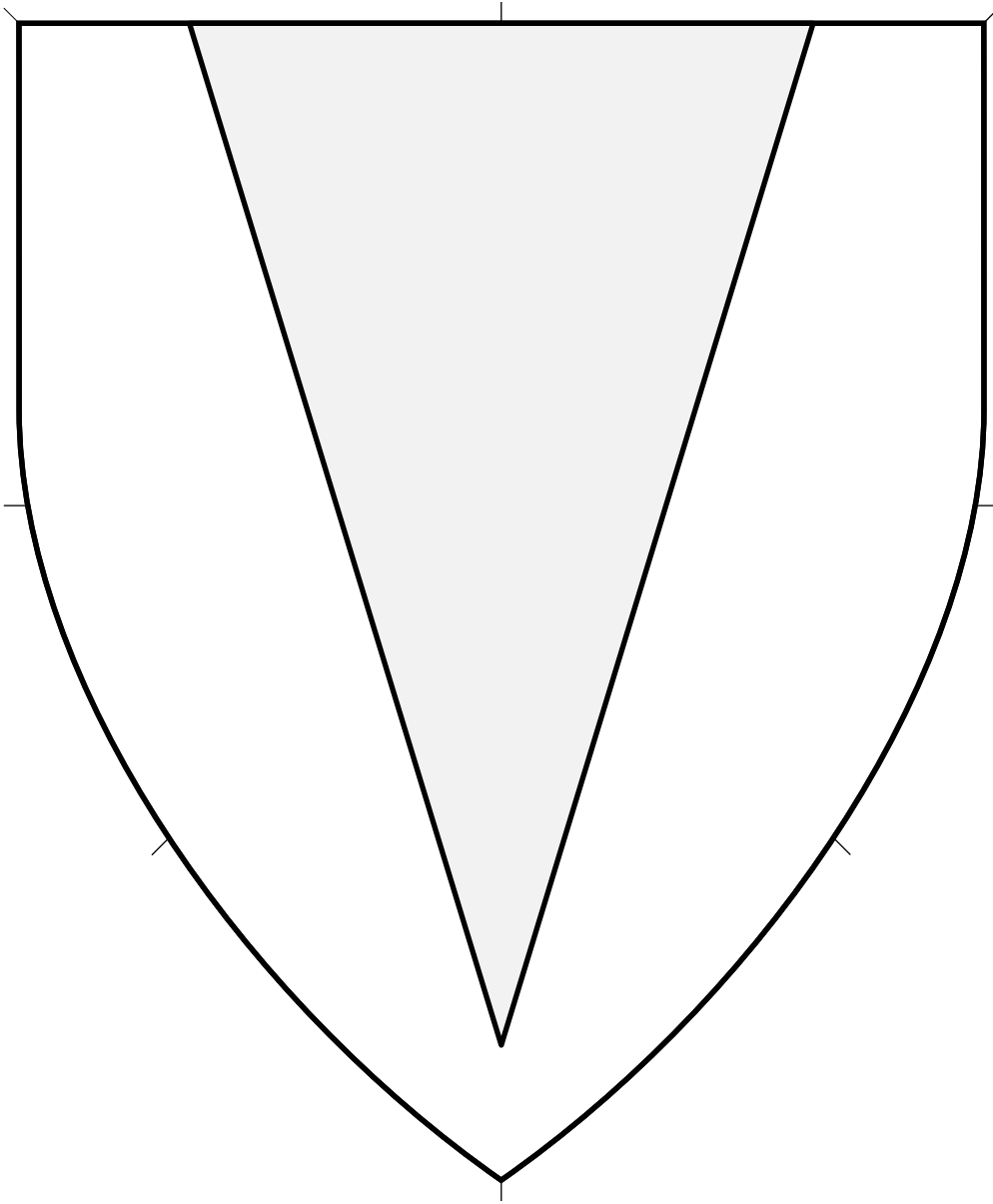

Central ordinary. Width at chief is anywhere from one third to two thirds of the total, or less if there are multiples. May be throughout, reaching the base, or not.

Pile (2) 4.532

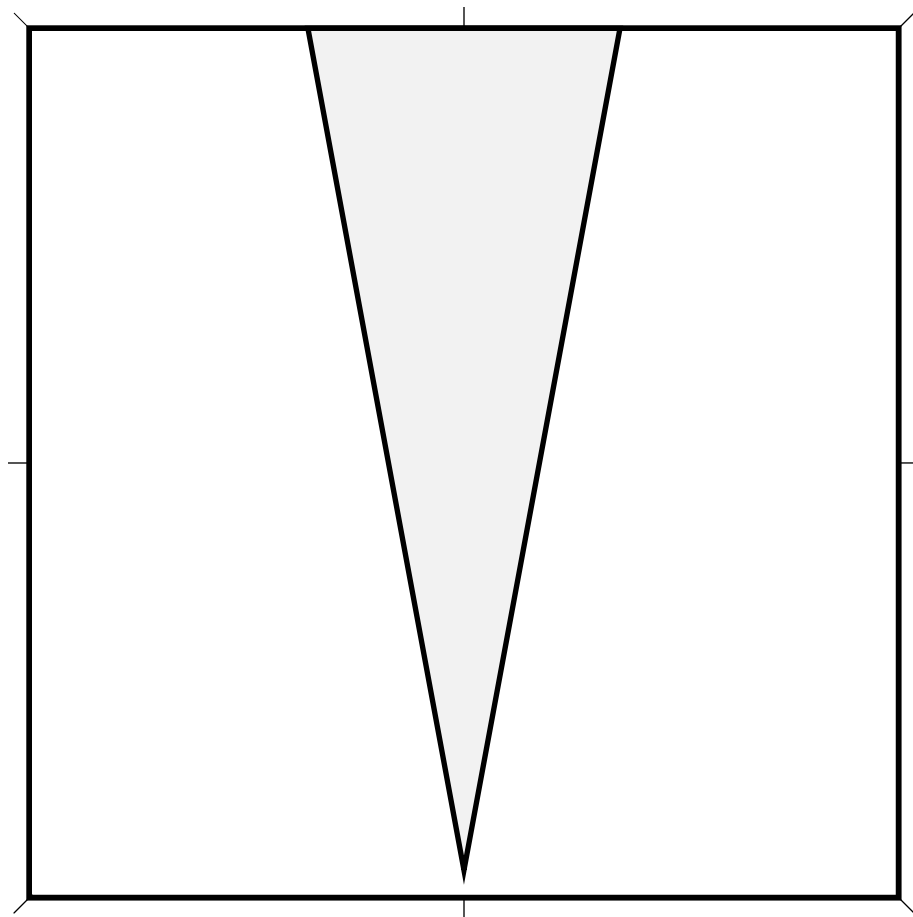
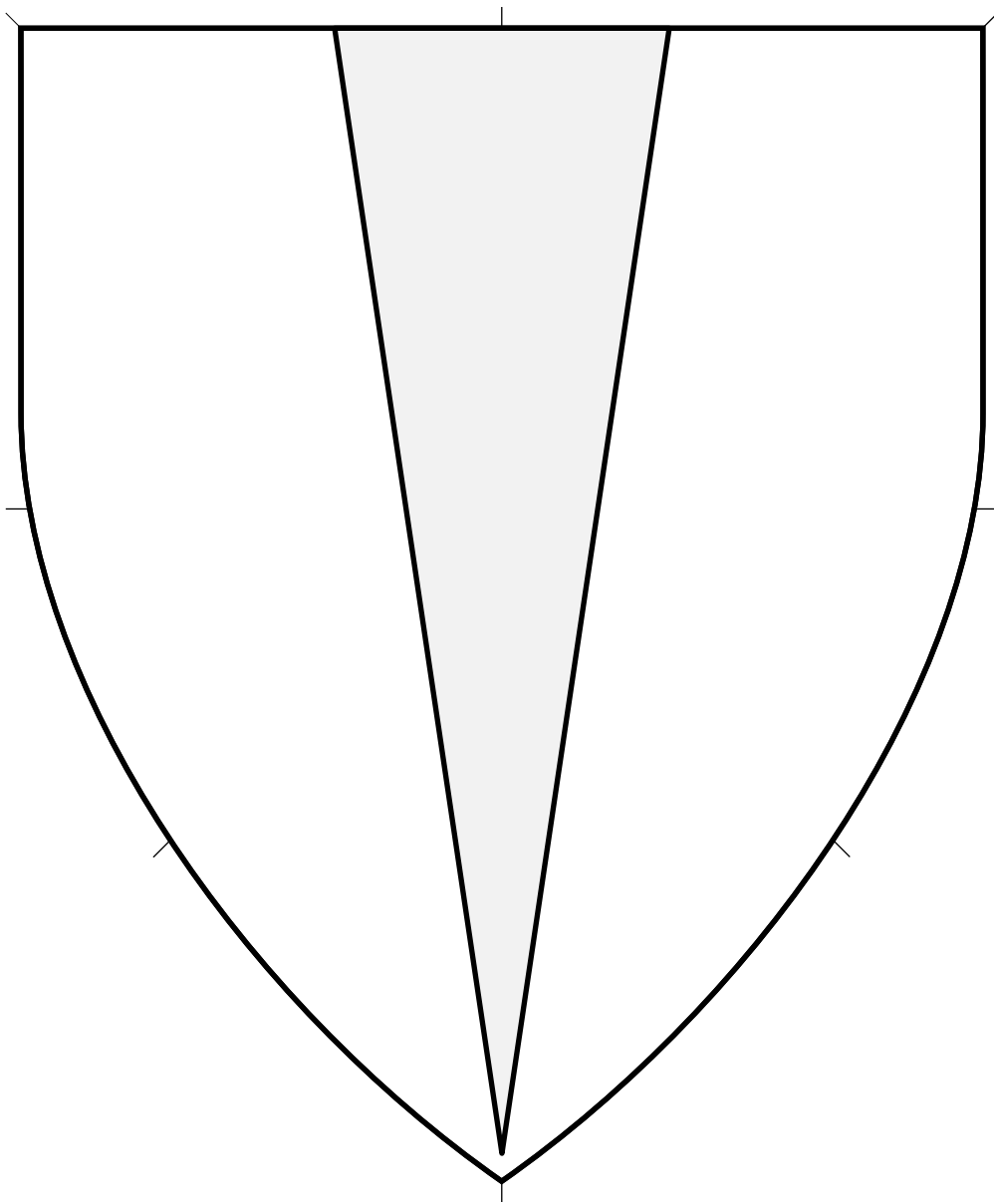

Central ordinary. Width at chief is anywhere from one third to two thirds of the total, or less if there are multiples. May be throughout, reaching the base, or not.

This is a skinny pile.

Pile (3) 4.533

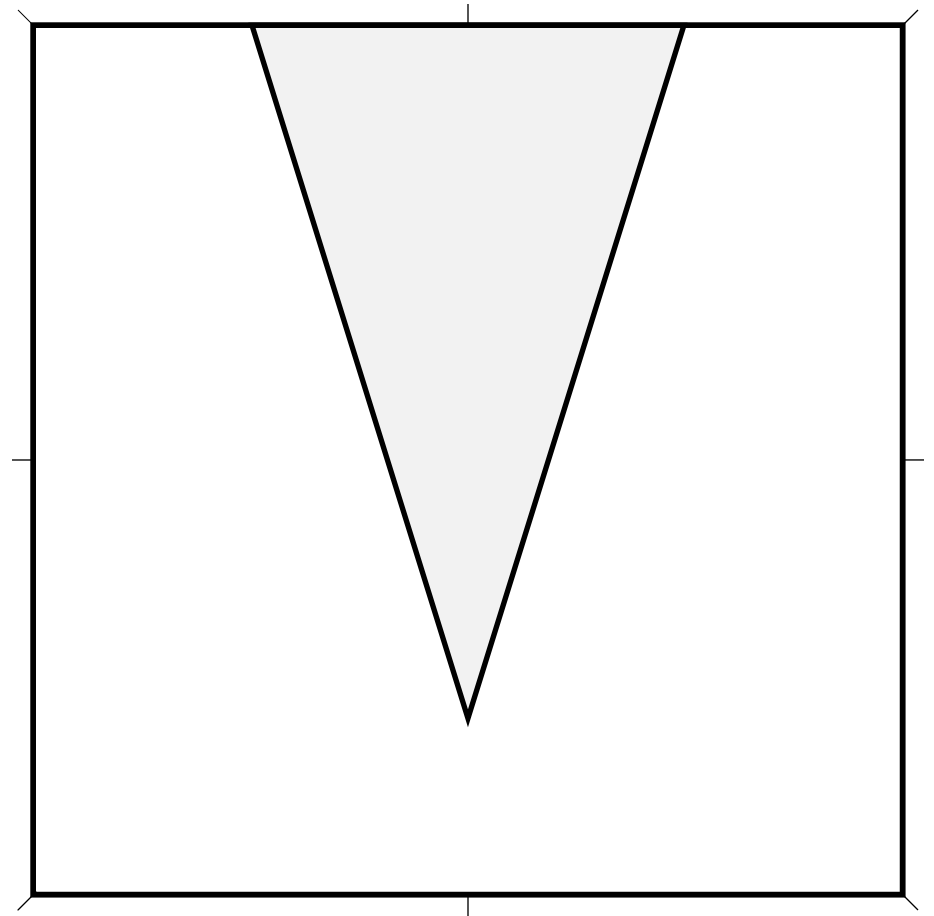
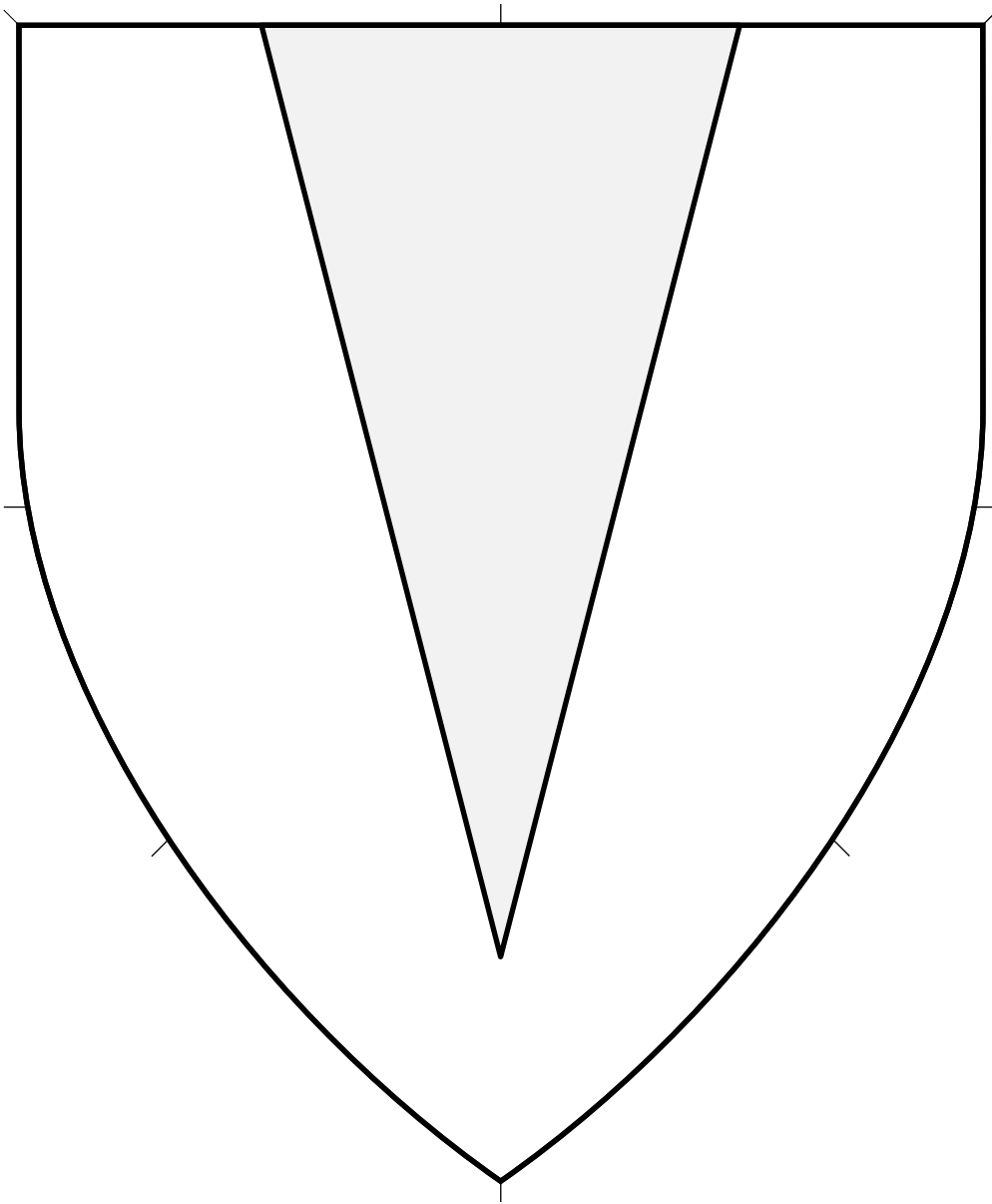

Central ordinary. Width at chief is anywhere from one third to two thirds of the total, or less if there are multiples. May be throughout, reaching the base, or not.

This is a short pile. Piles that are 75-85% of the height of the field, are considered an SFCP. Piles shorter than this would be unregistrable.

Pile (4) 4.534

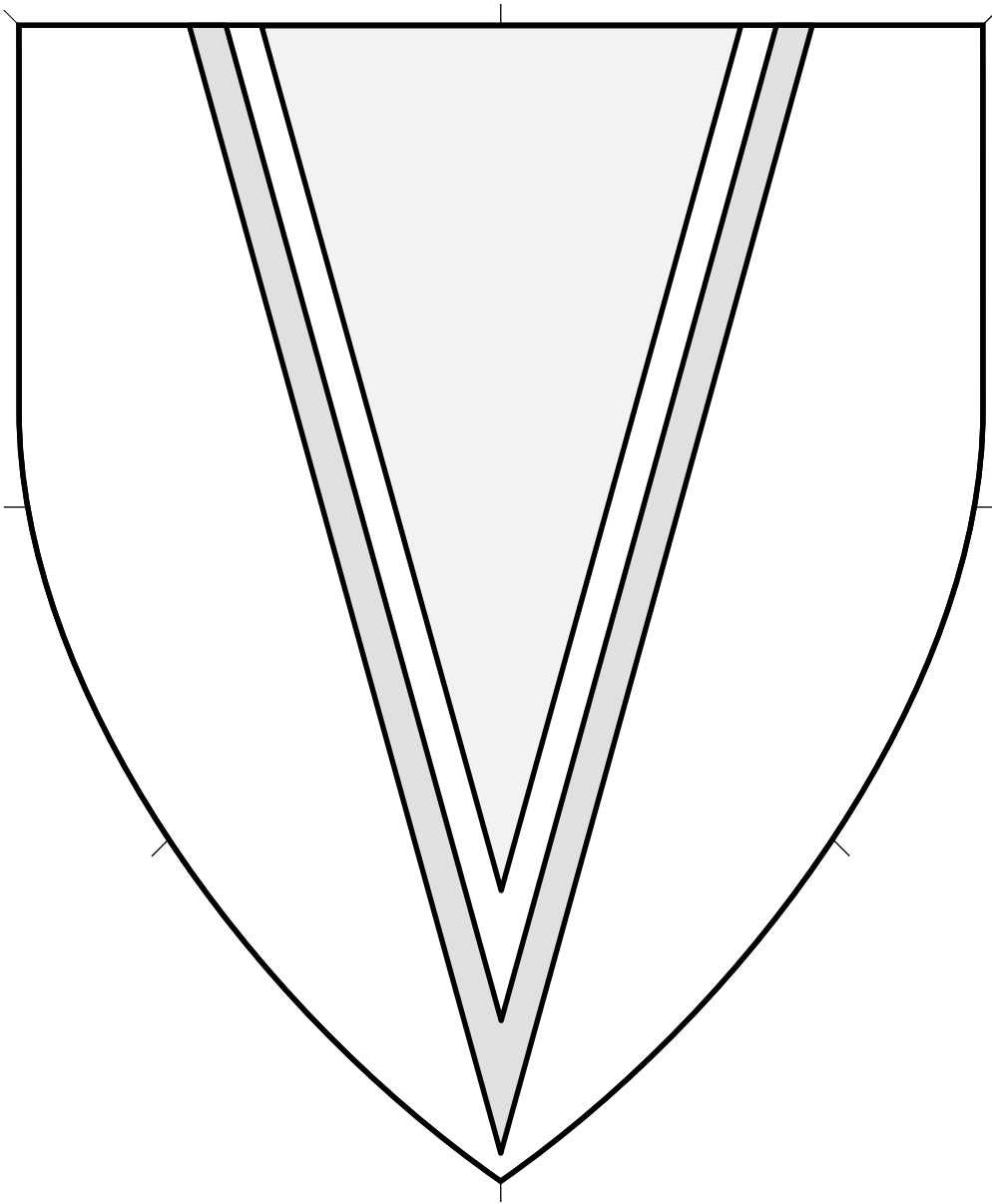

Central ordinary cotised.

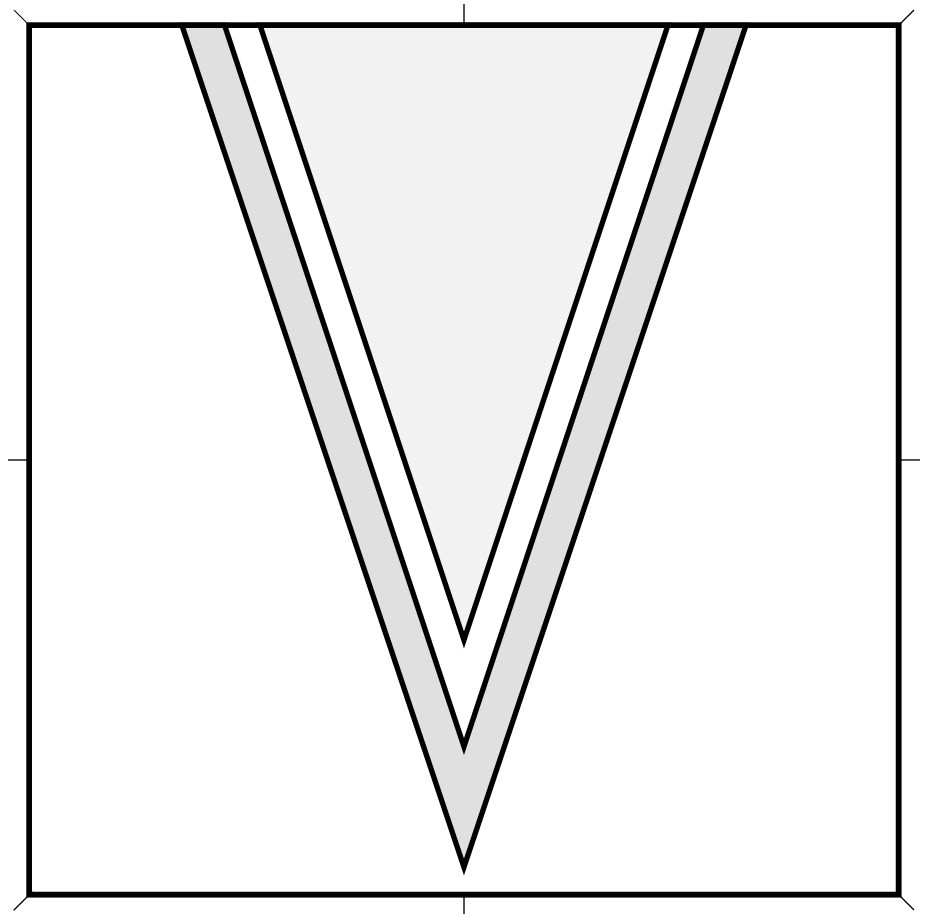

Pile Cotised (1) 4.535

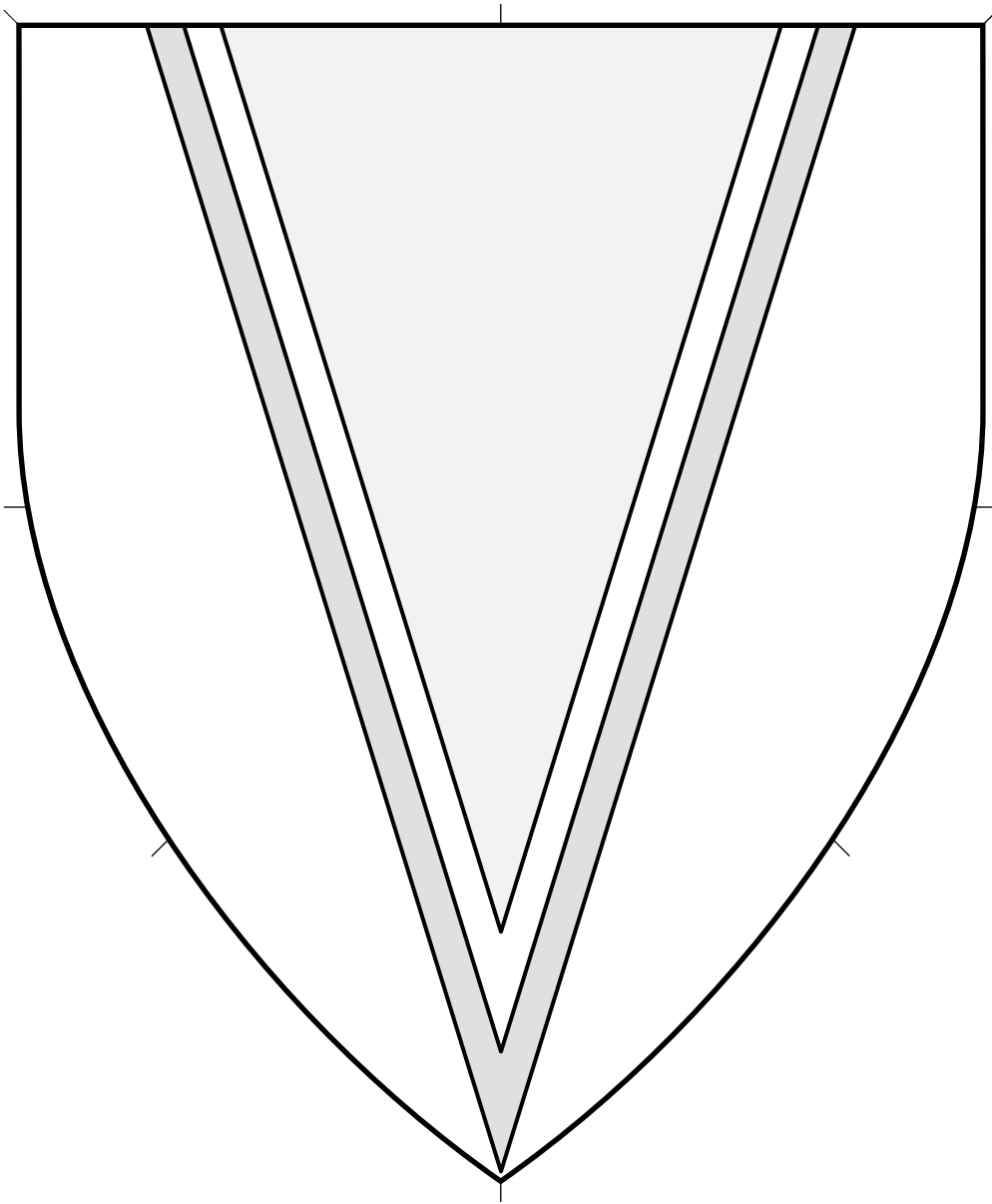

Central ordinary cotised.

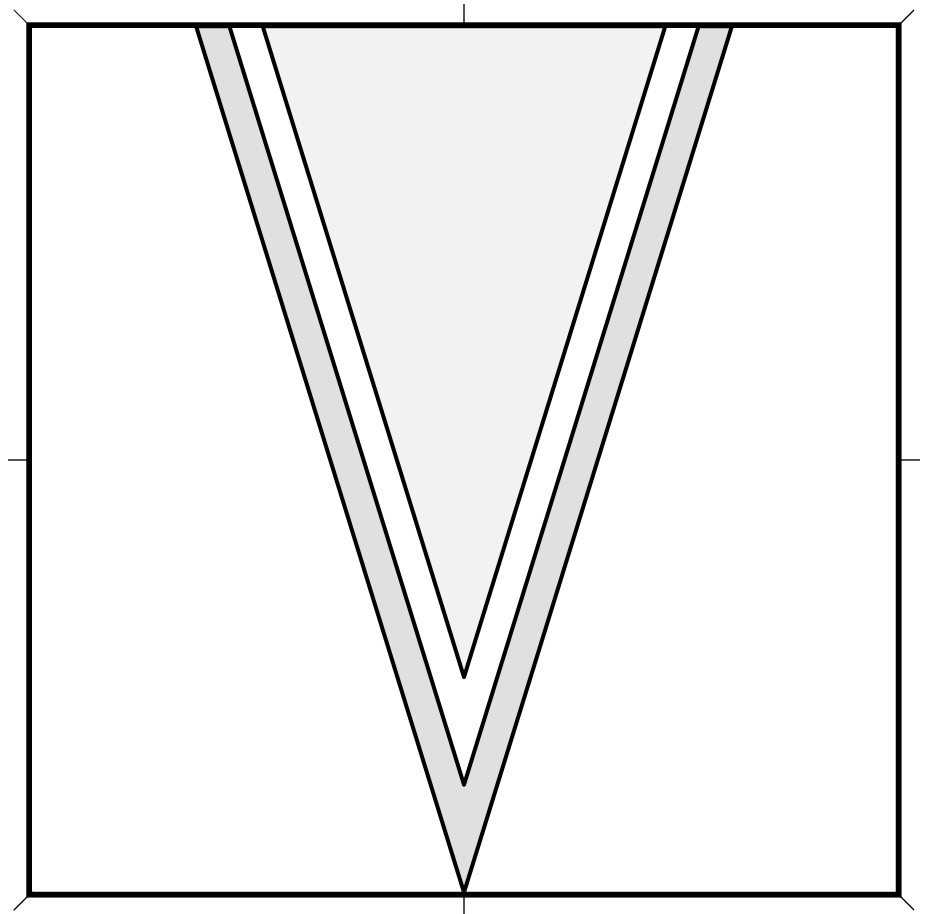

Pile Cotised (2) 4.536

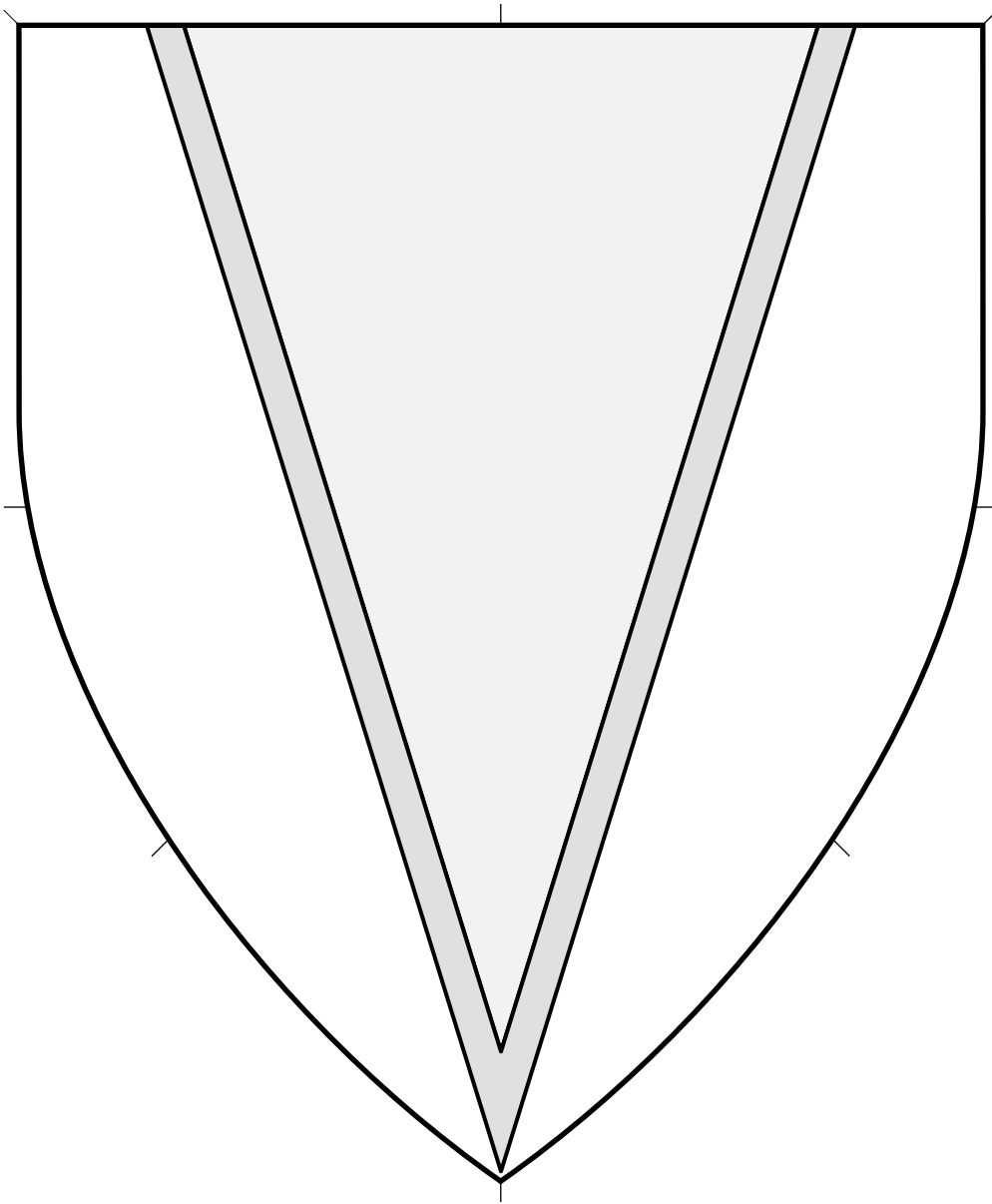

Central ordinary.

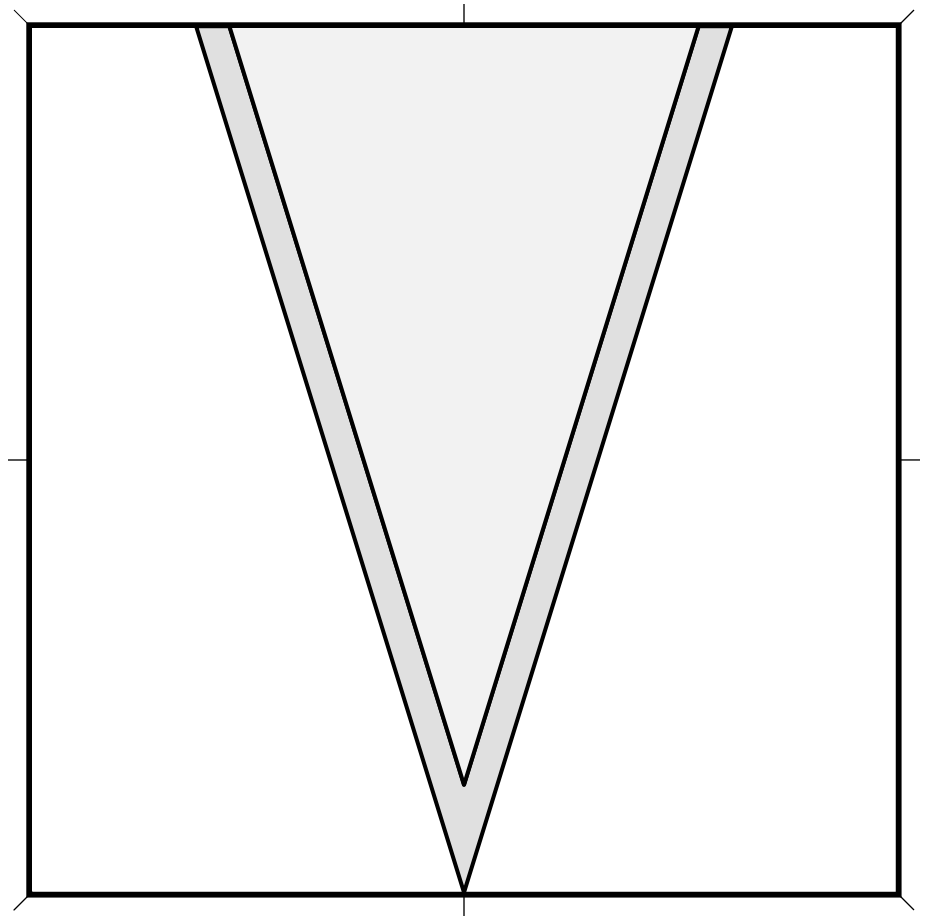

Pile Fimbriated • 4.537

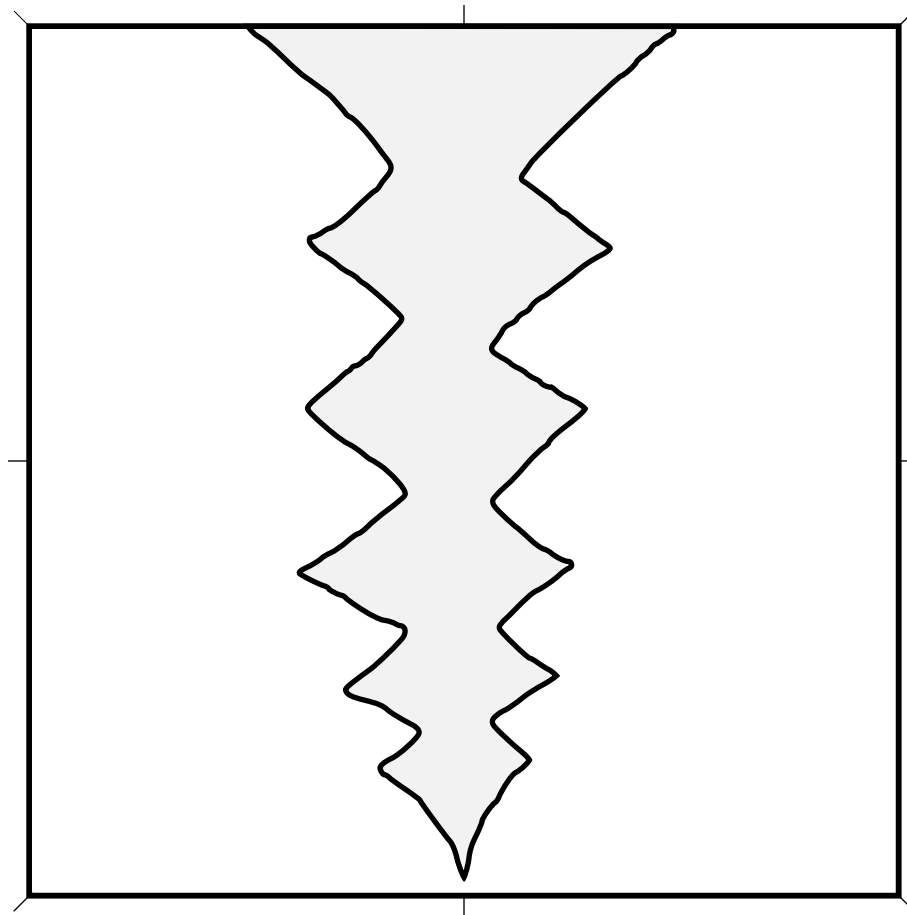
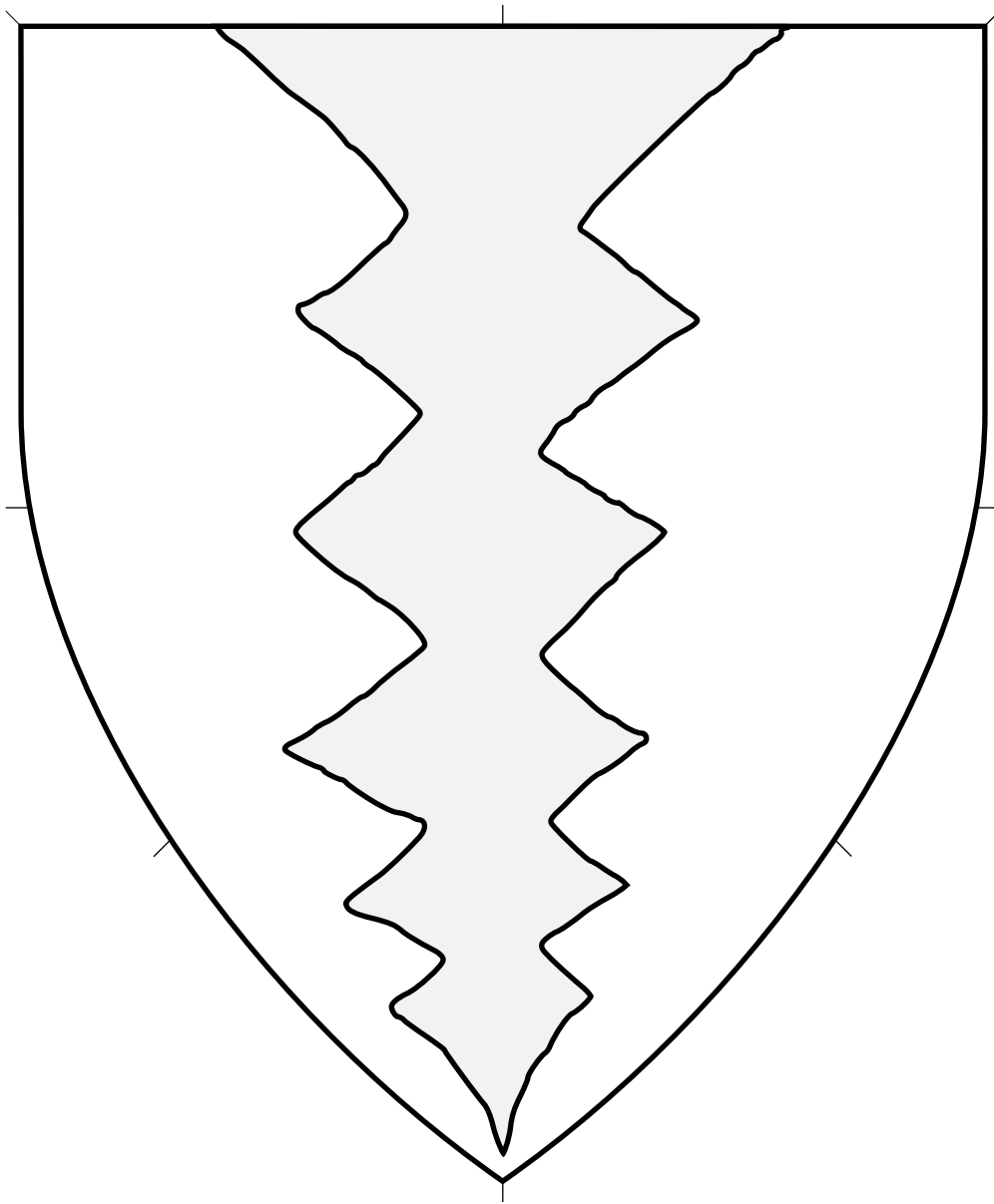

Central ordinary.

Source: Thomas Jenyn's Book. Artist unknown. (Folio 83v.)

Pile Indented (1) 4.538

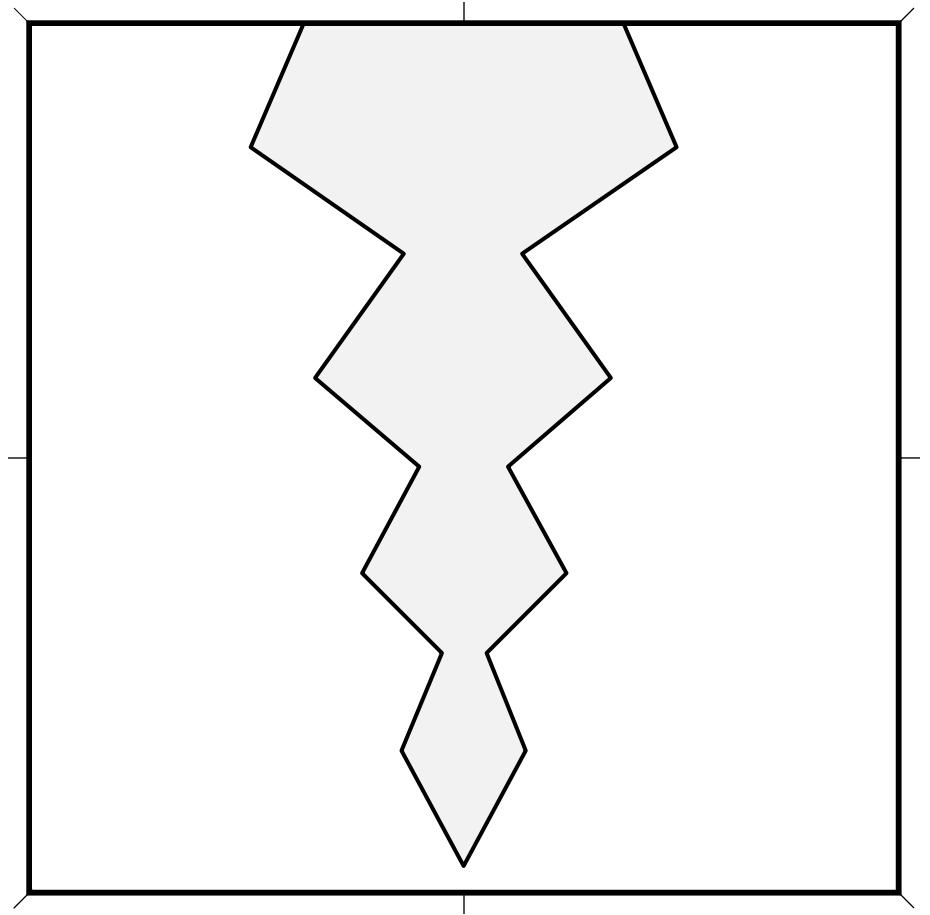
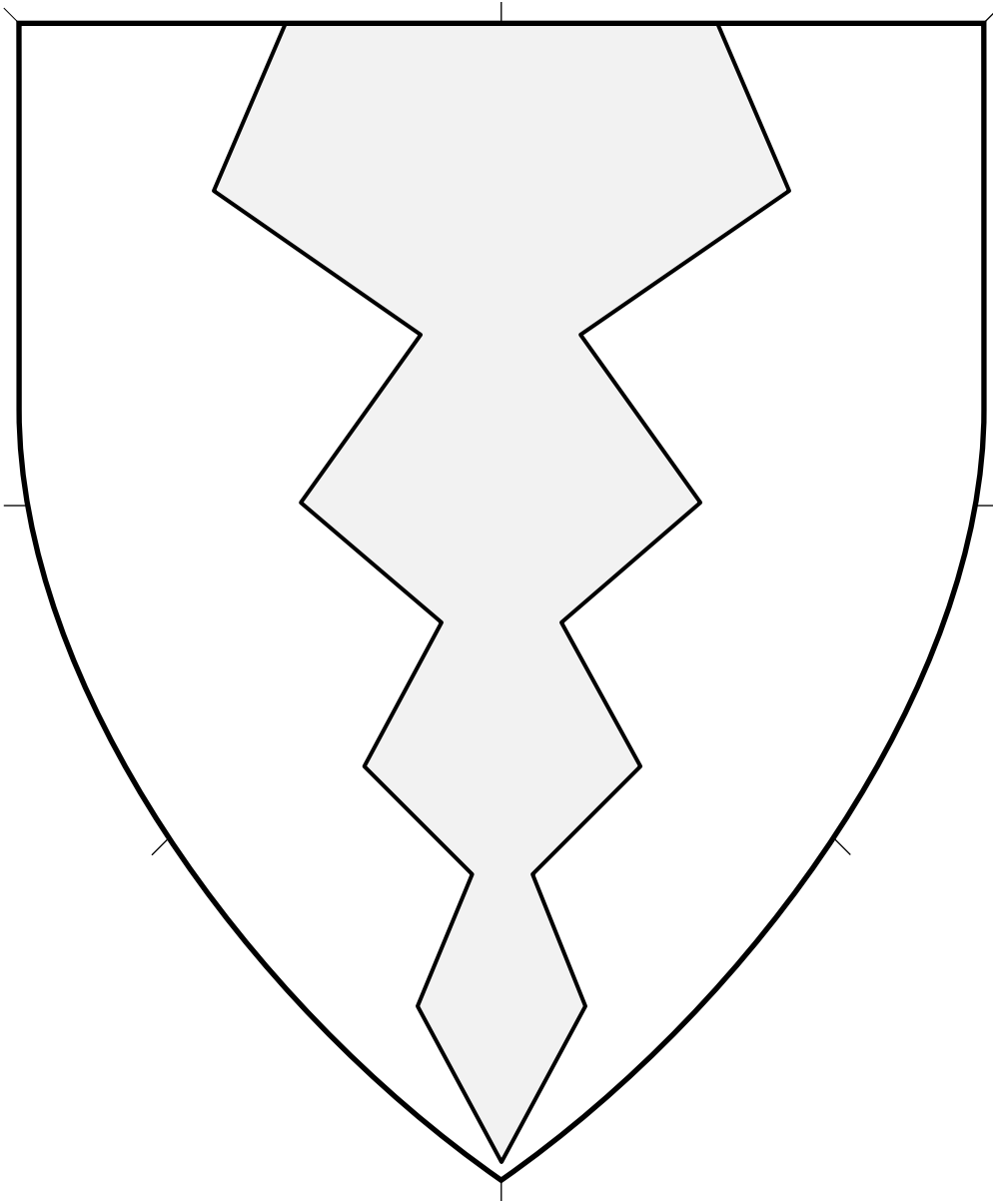

Central ordinary.
Artist: Forveleth Dundee.

Pile Indented (2) 4.539

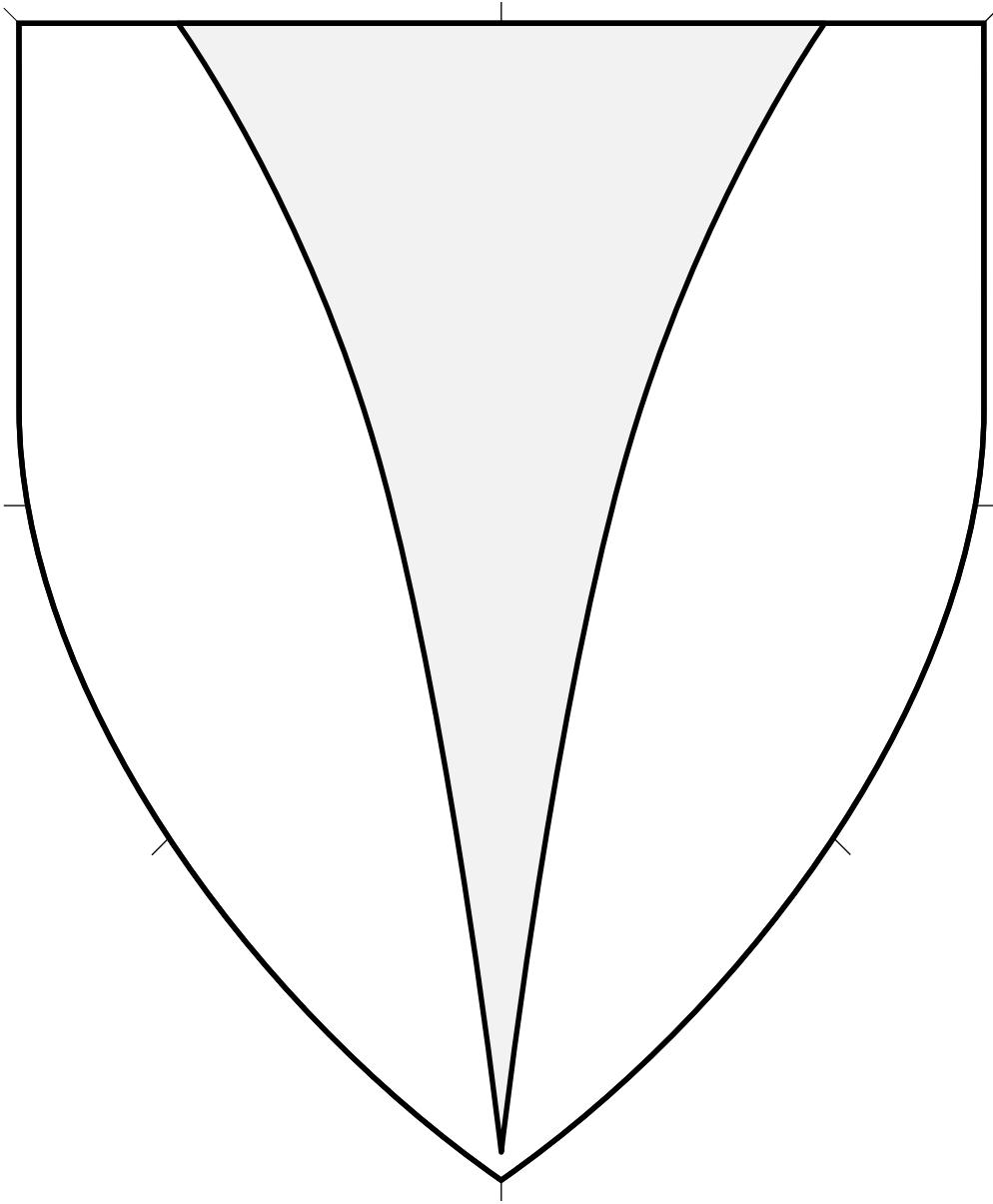

Central ordinary.

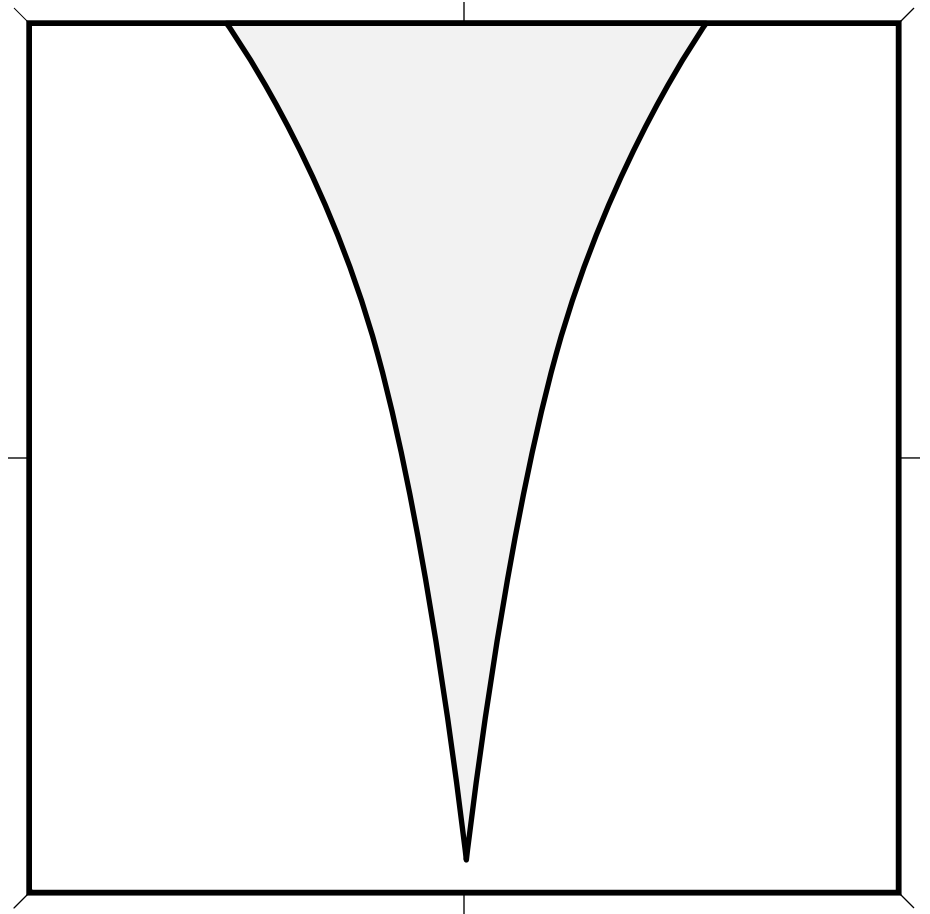

Pile Ployé (1) 4.540

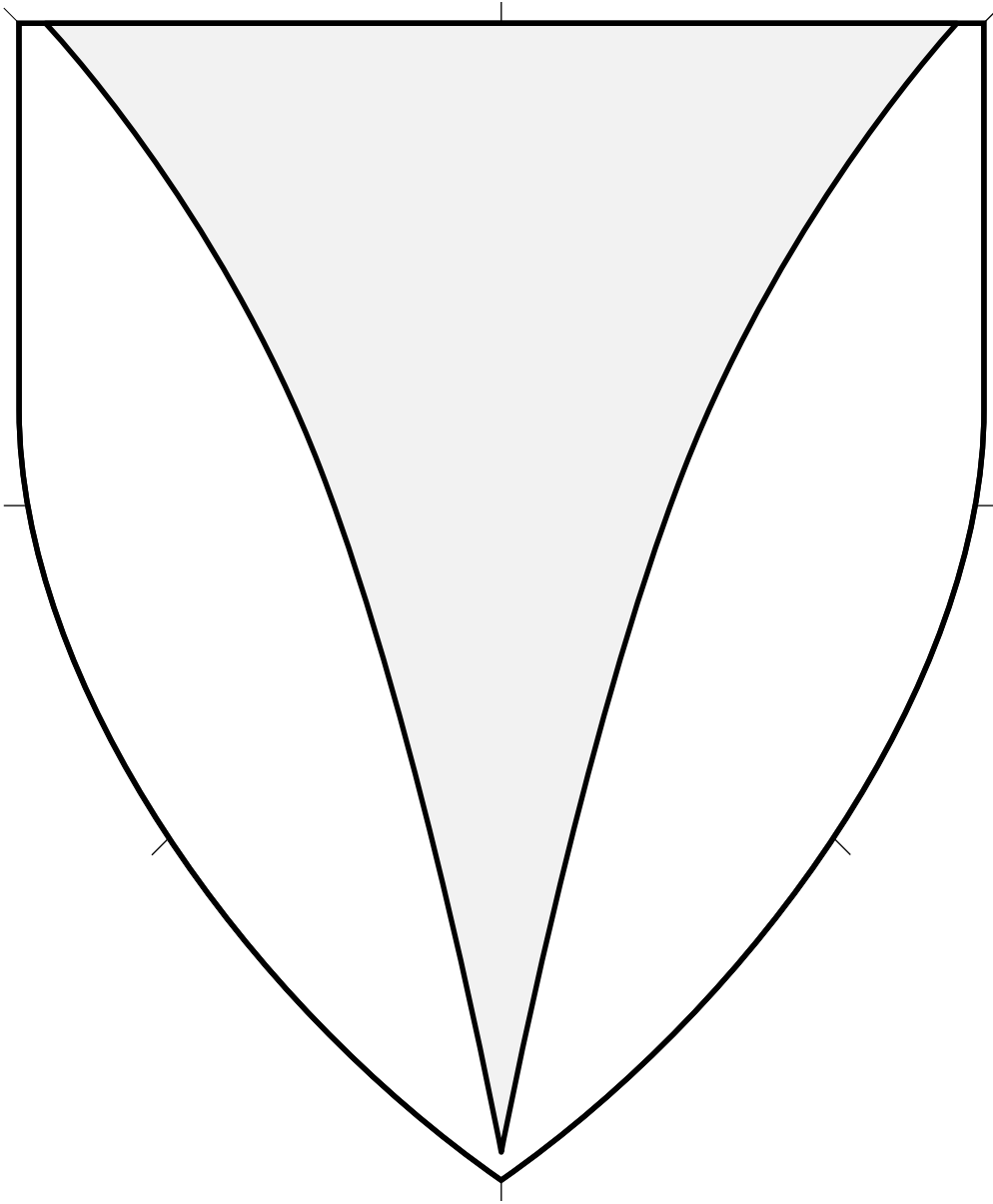

Central ordinary.

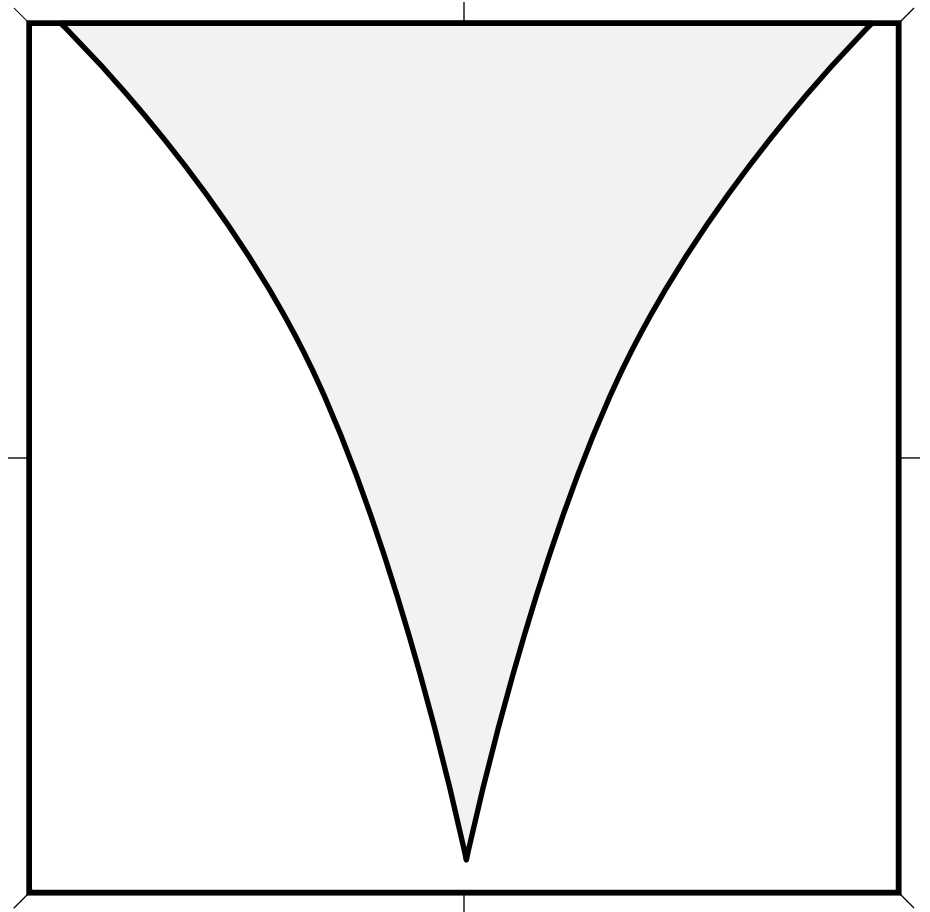

Pile Ployé (2) 4.541

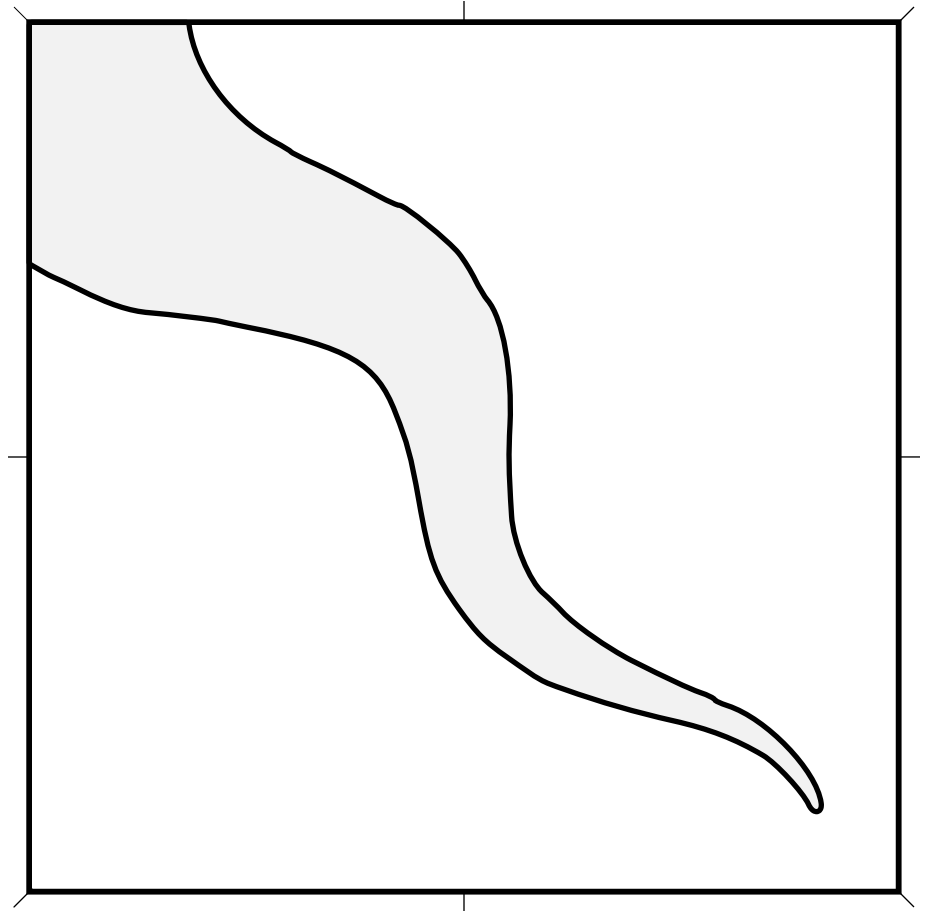
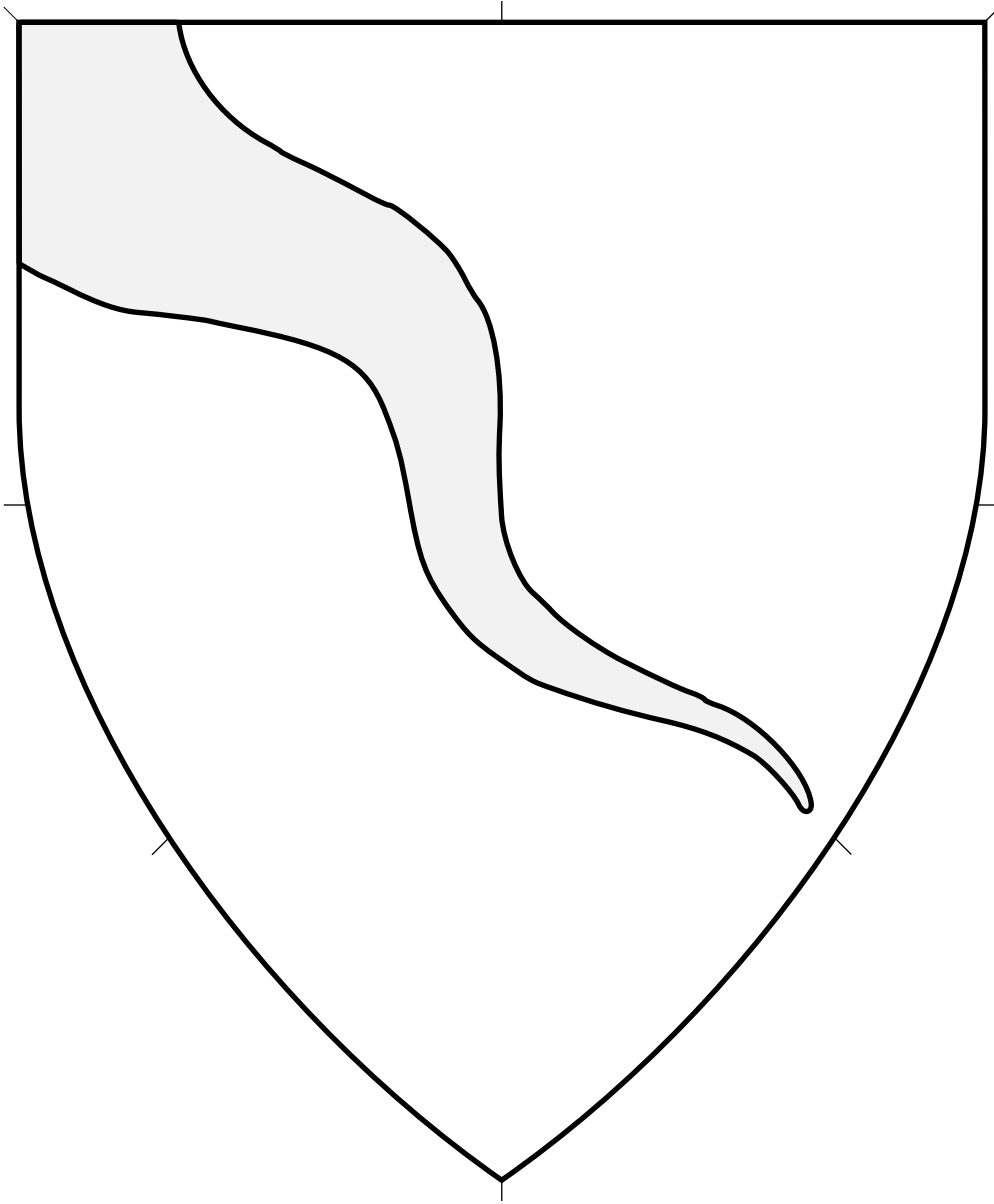

Central ordinary.

Source: The Accedence of Armorie.
Artist unknown. (From folio 69r.)

Pile Wavy Issuant From Dexter Chief 4.542

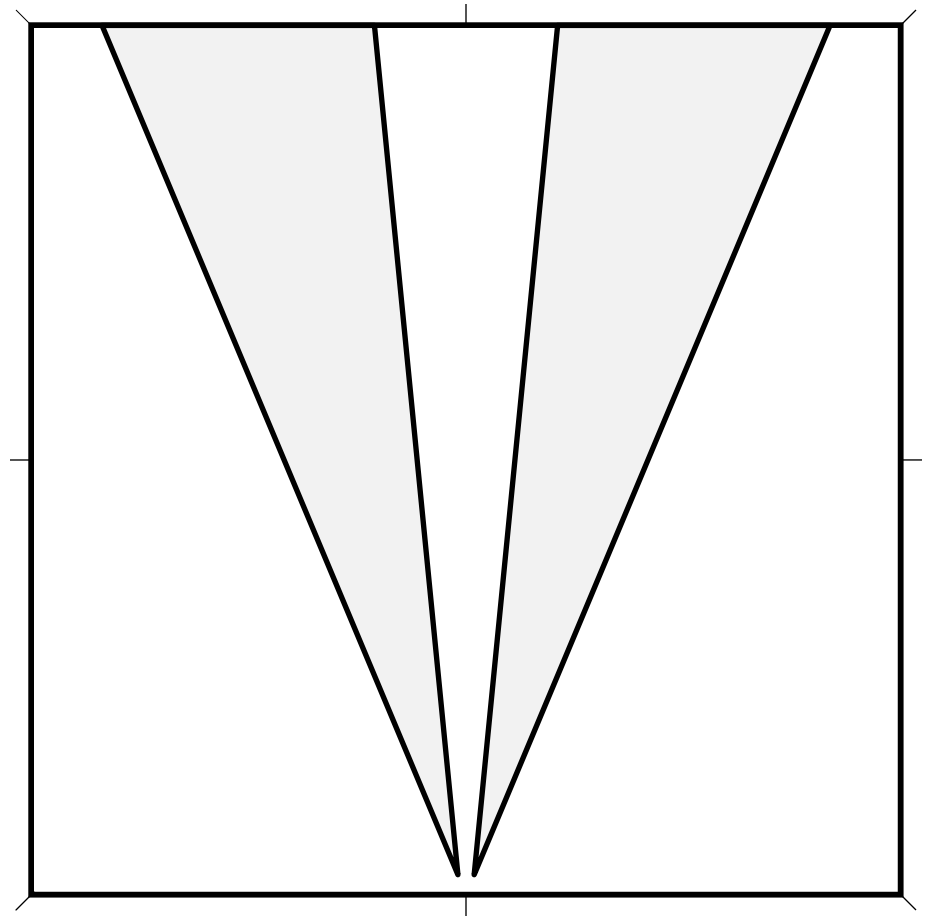
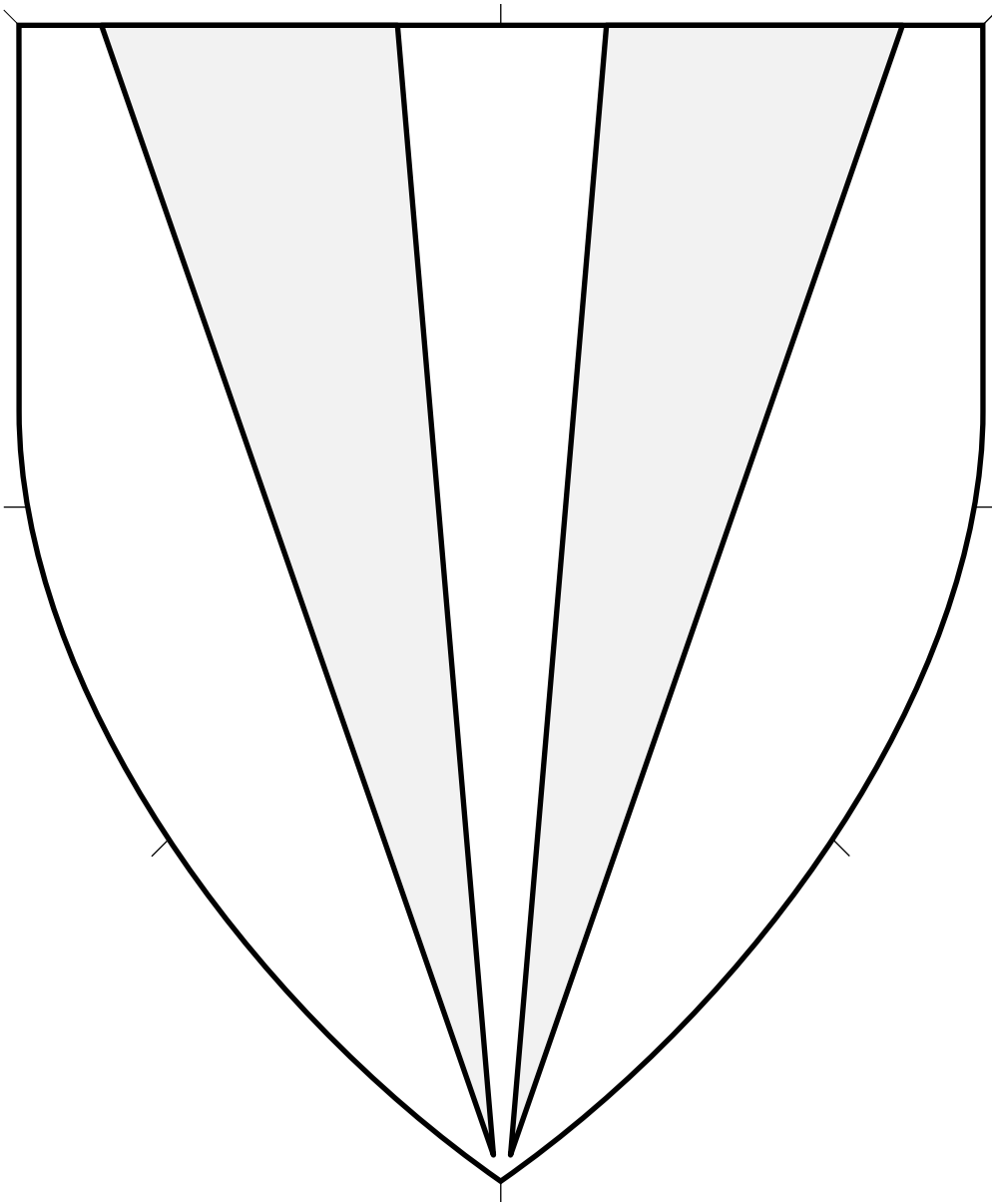

Central ordinary. May be throughout, reaching the base, or not.

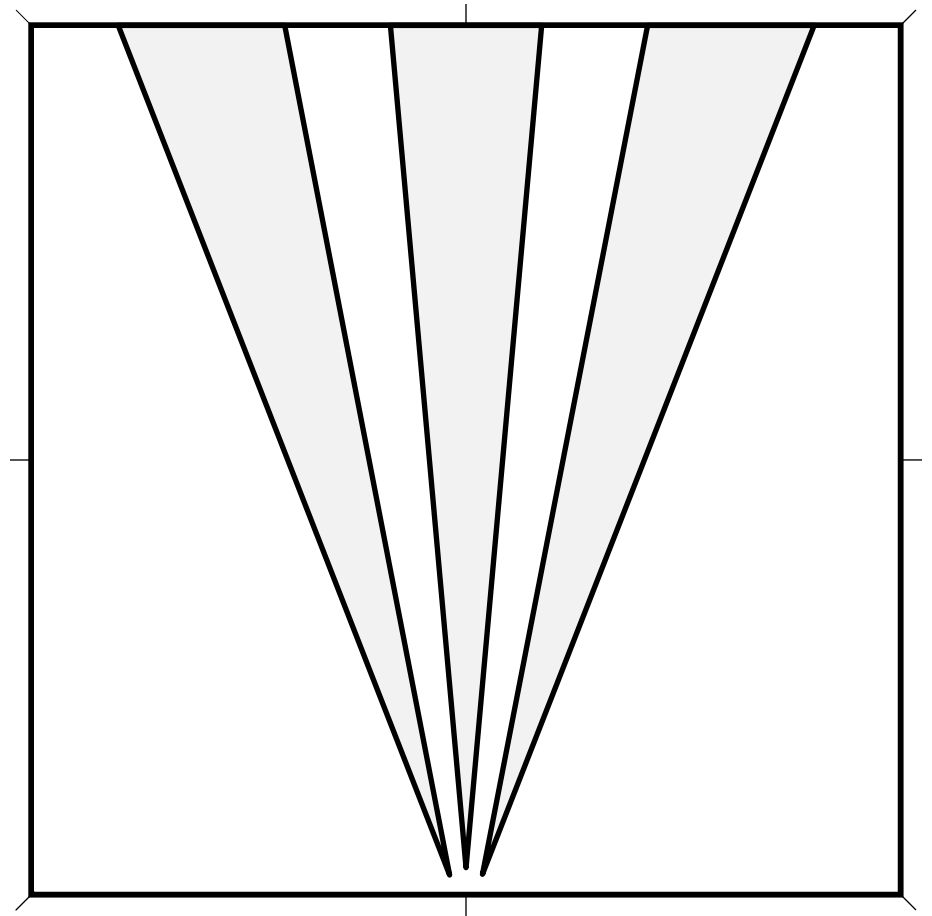
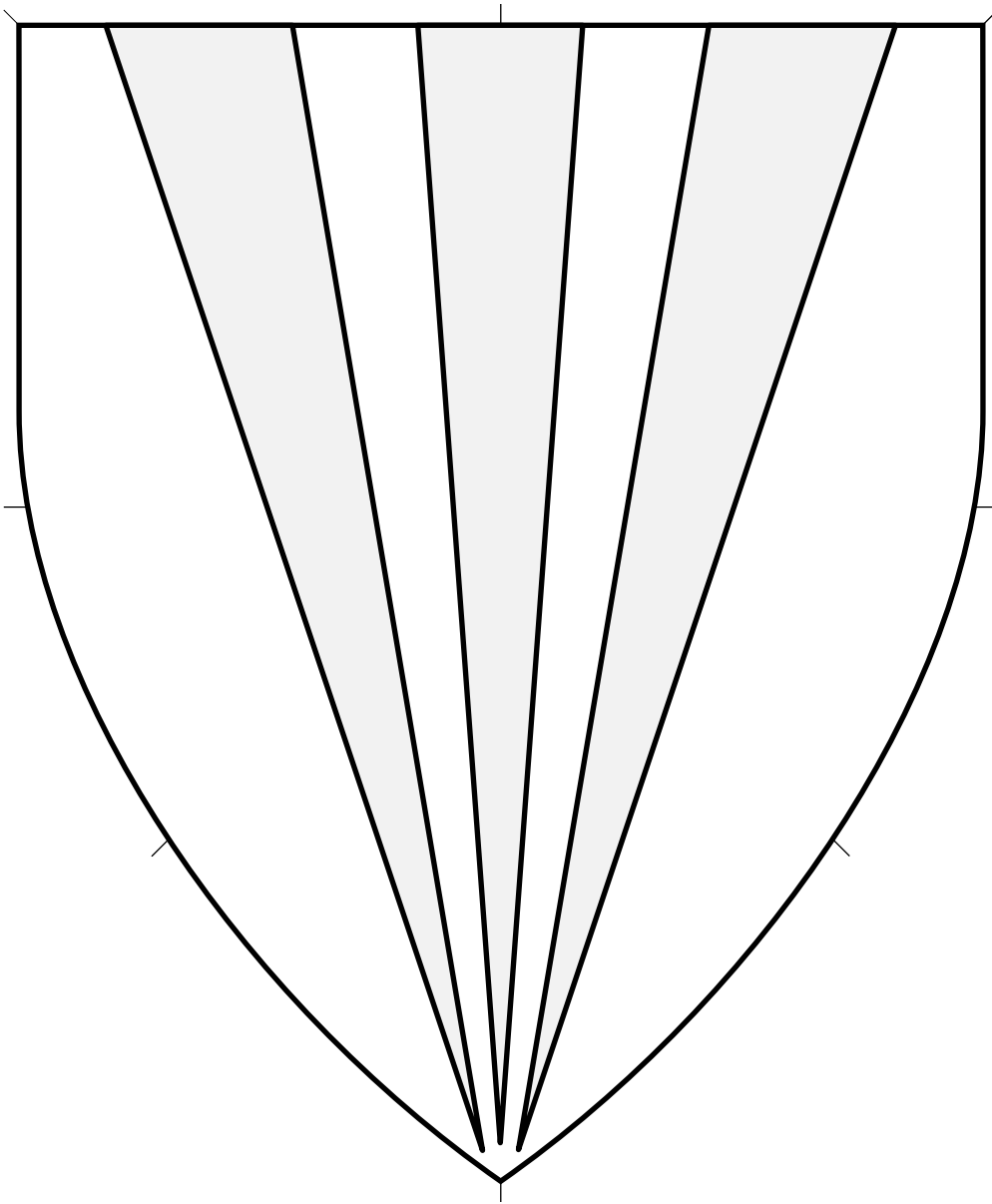

Central ordinary. May be throughout, reaching the base, or not.

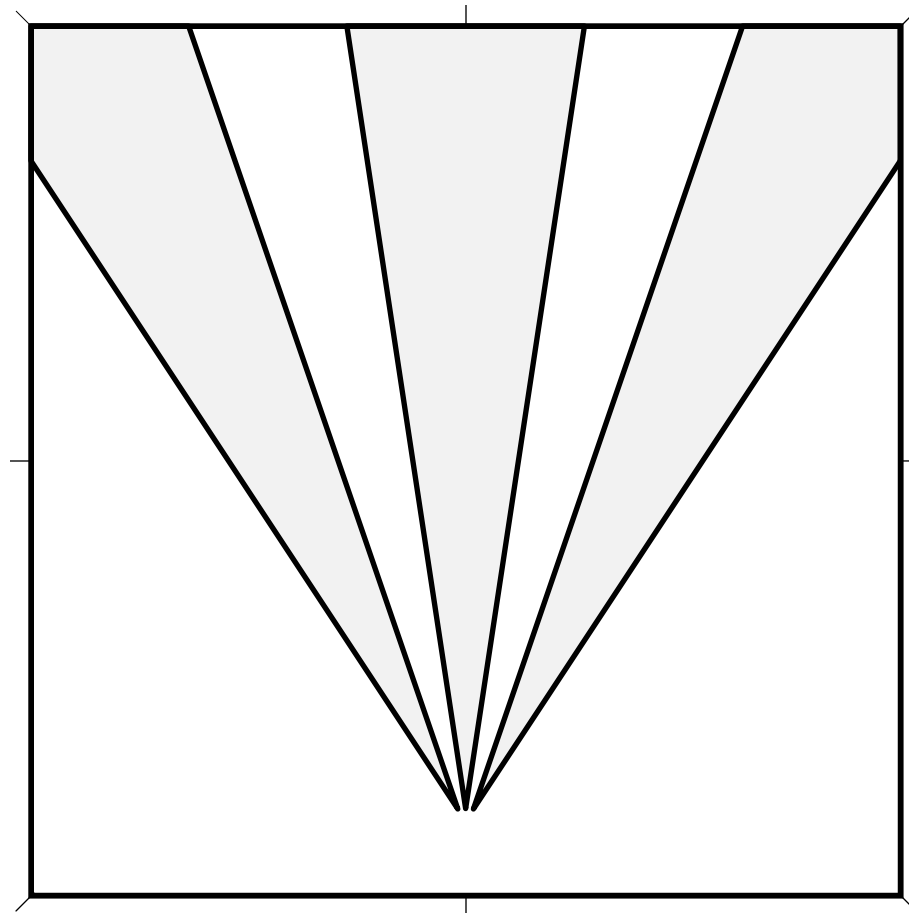
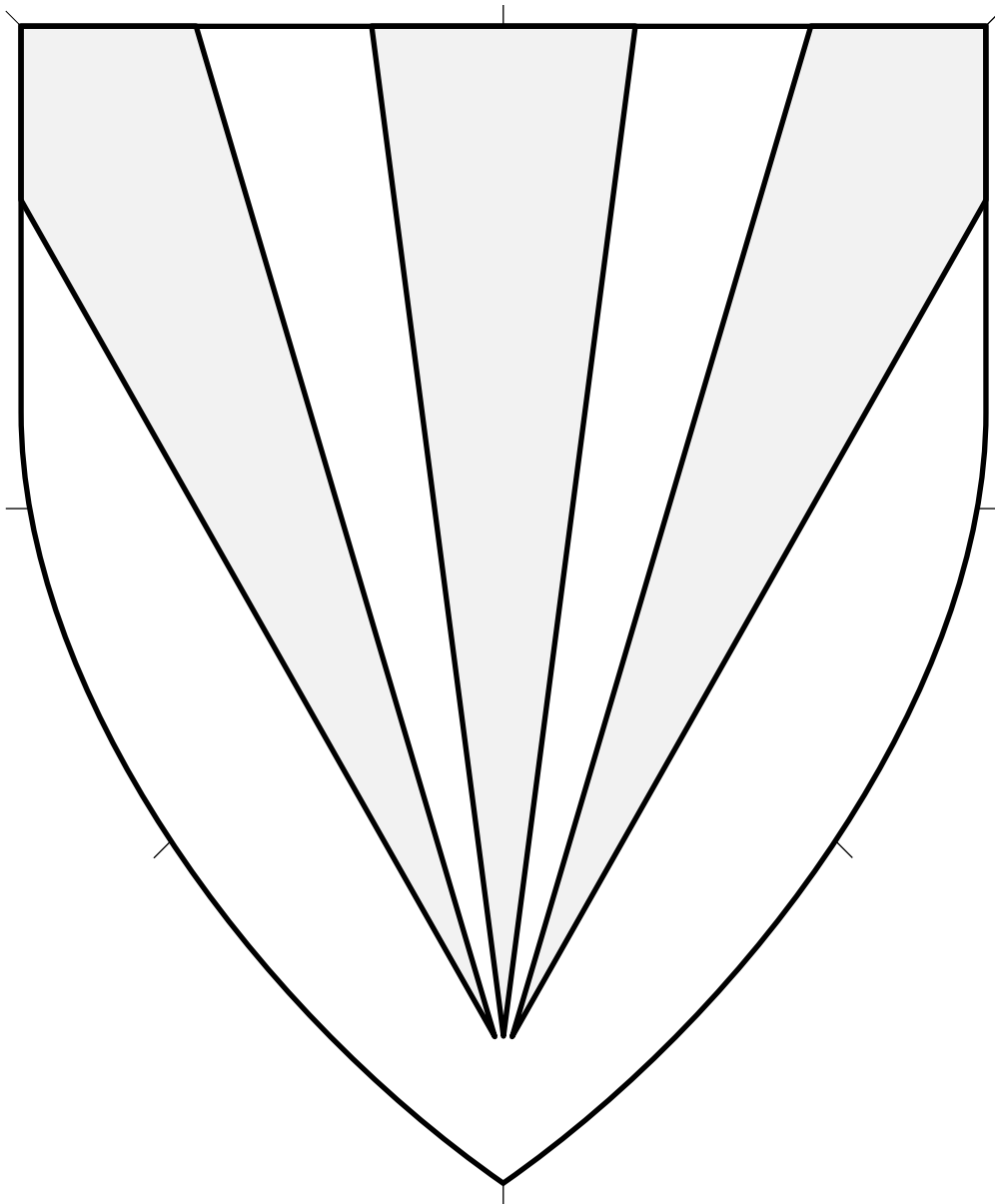

Central ordinary.

Source: English Arms A. Artist unknown. (Page 45.)

Piles, 3 (2) 4.545

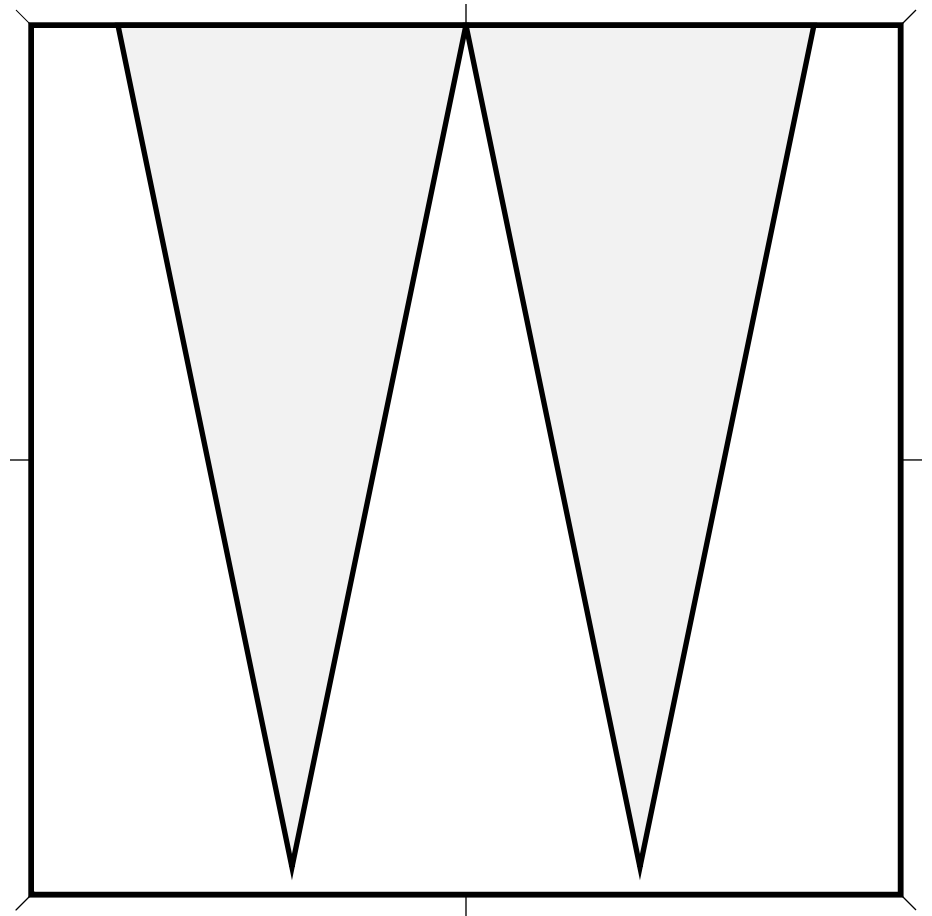
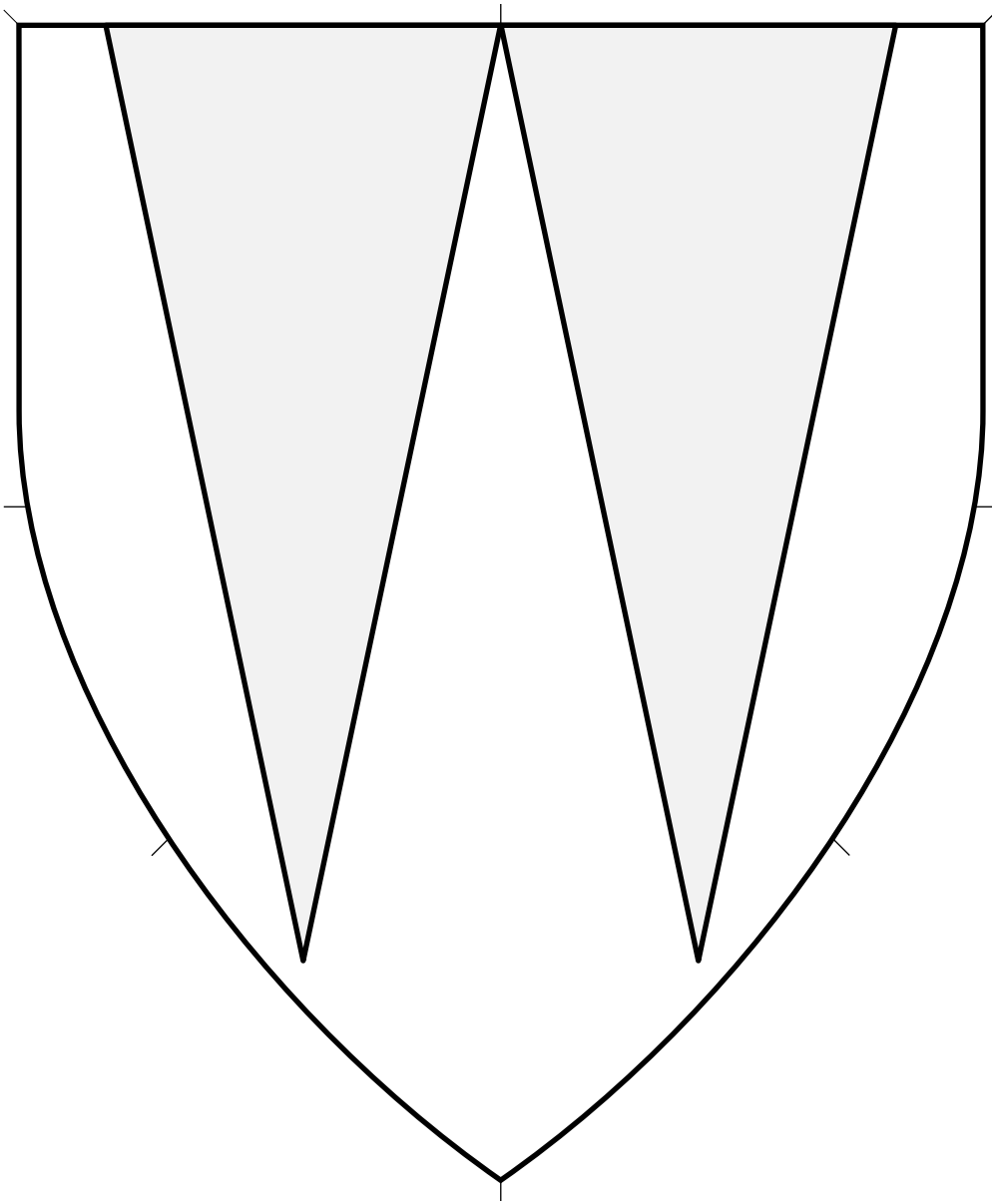

Central ordinary. May be throughout, reaching the base, or not.

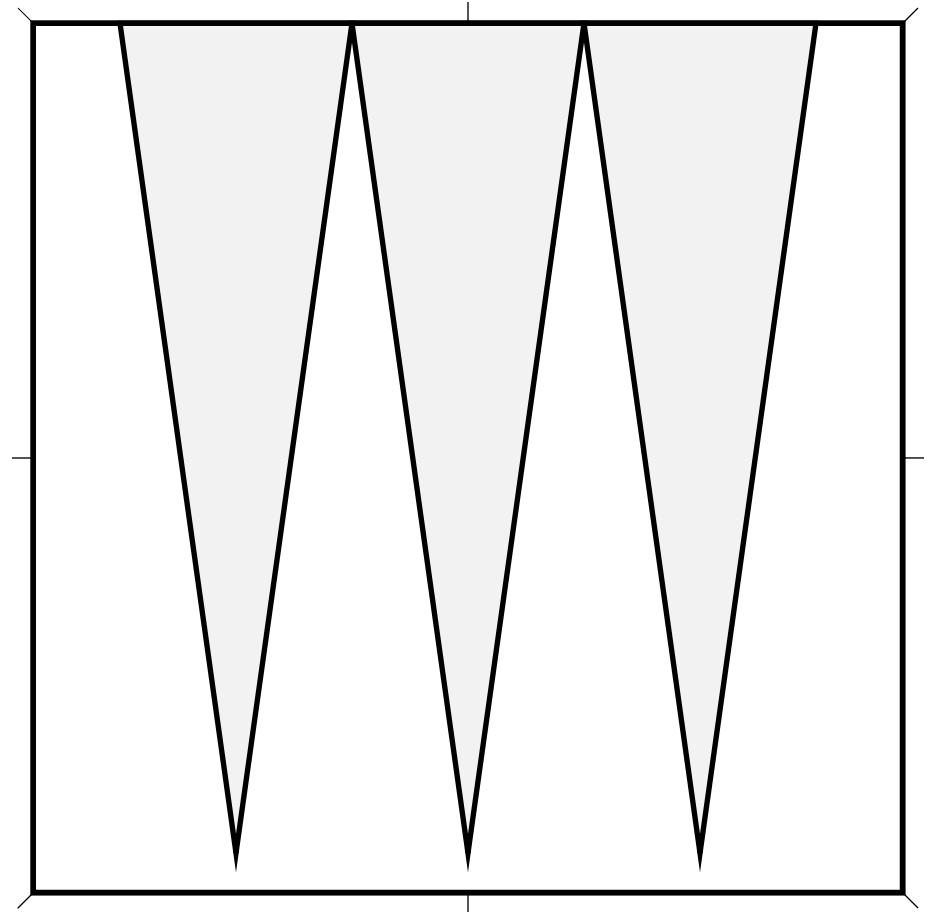
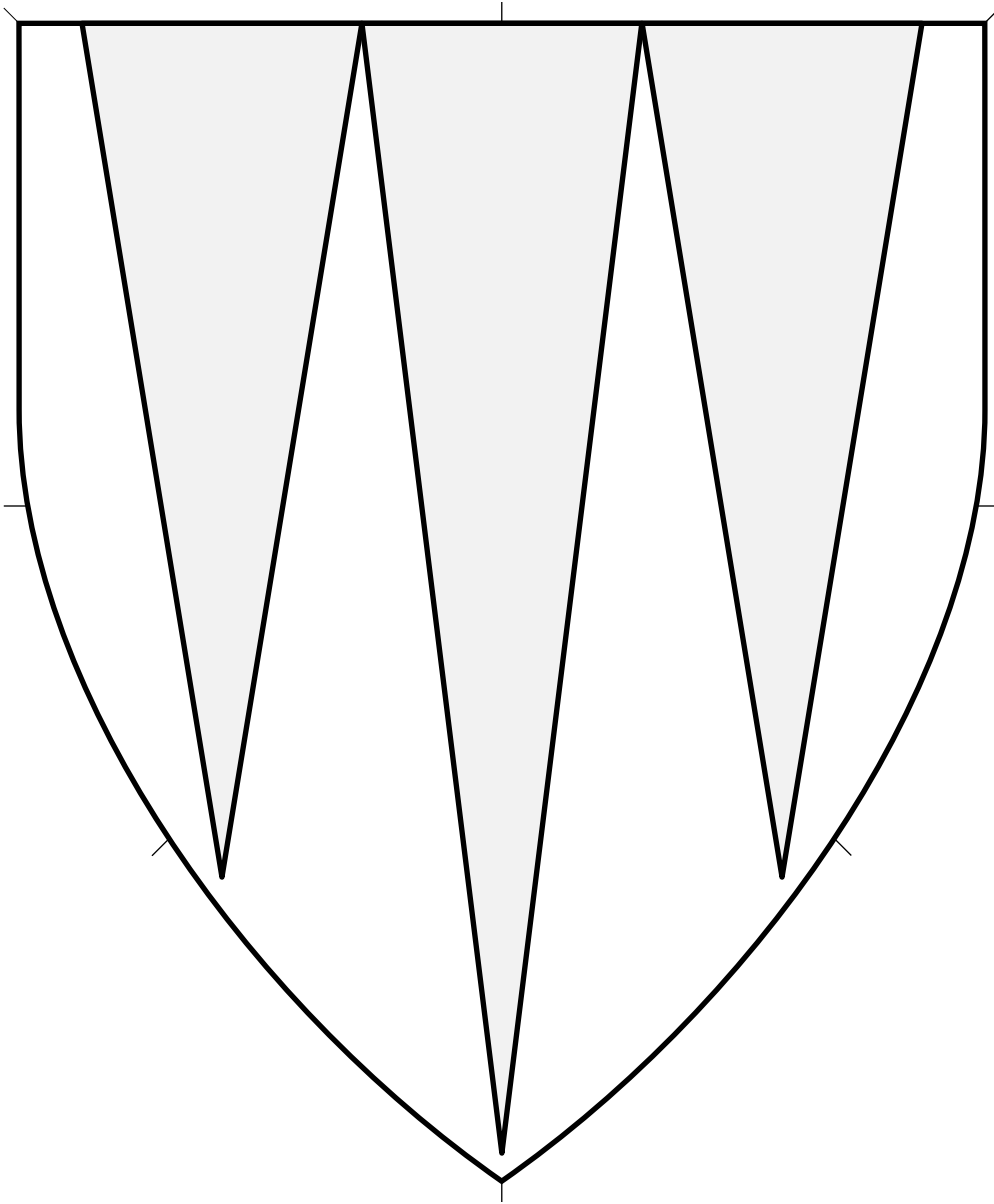

Central ordinary. May be throughout, reaching the base, or not.

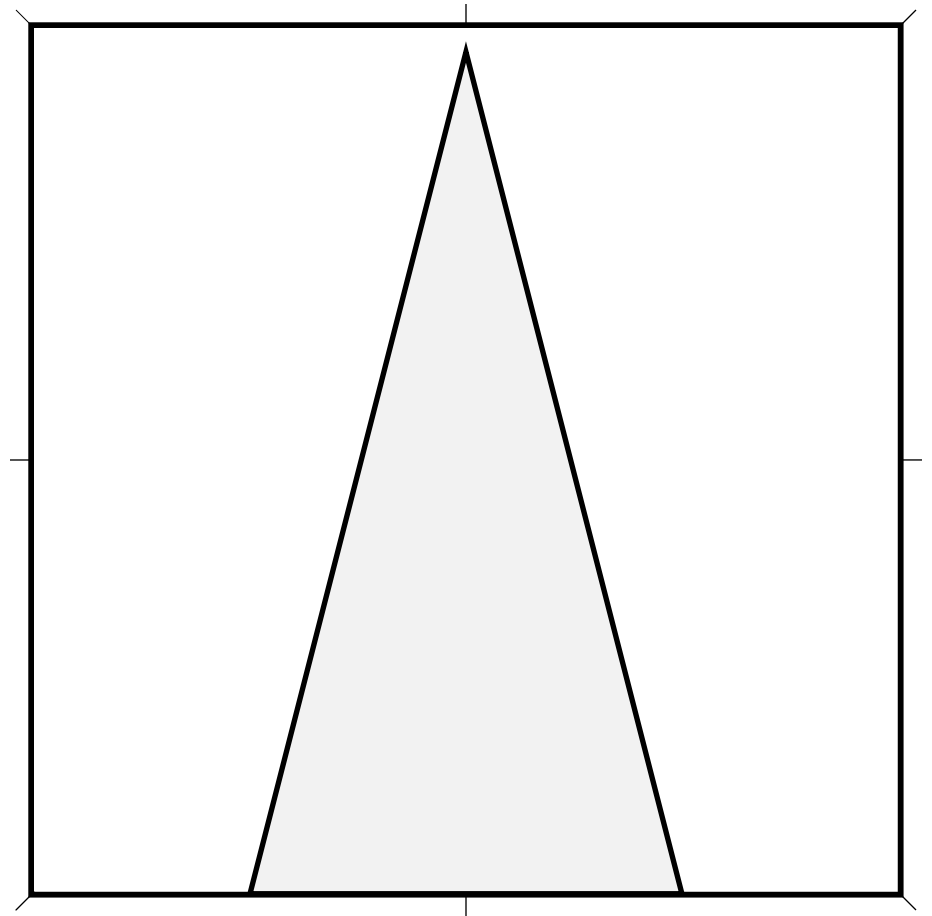
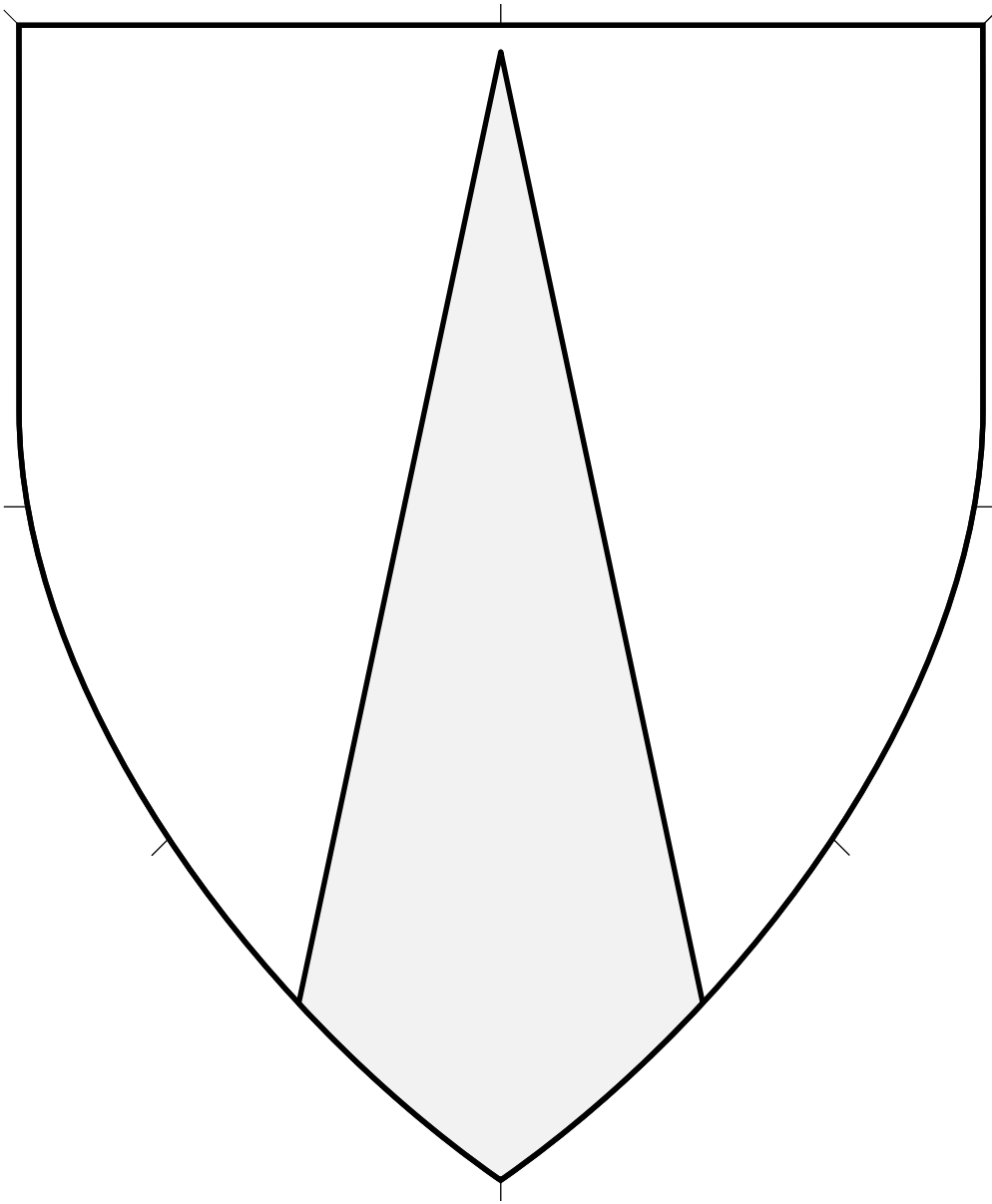

Central ordinary. Width at base is anywhere from one third to two thirds of total, or less if there are multiples. May be throughout, reaching the chief, or not.

Pile Inverted 4.548

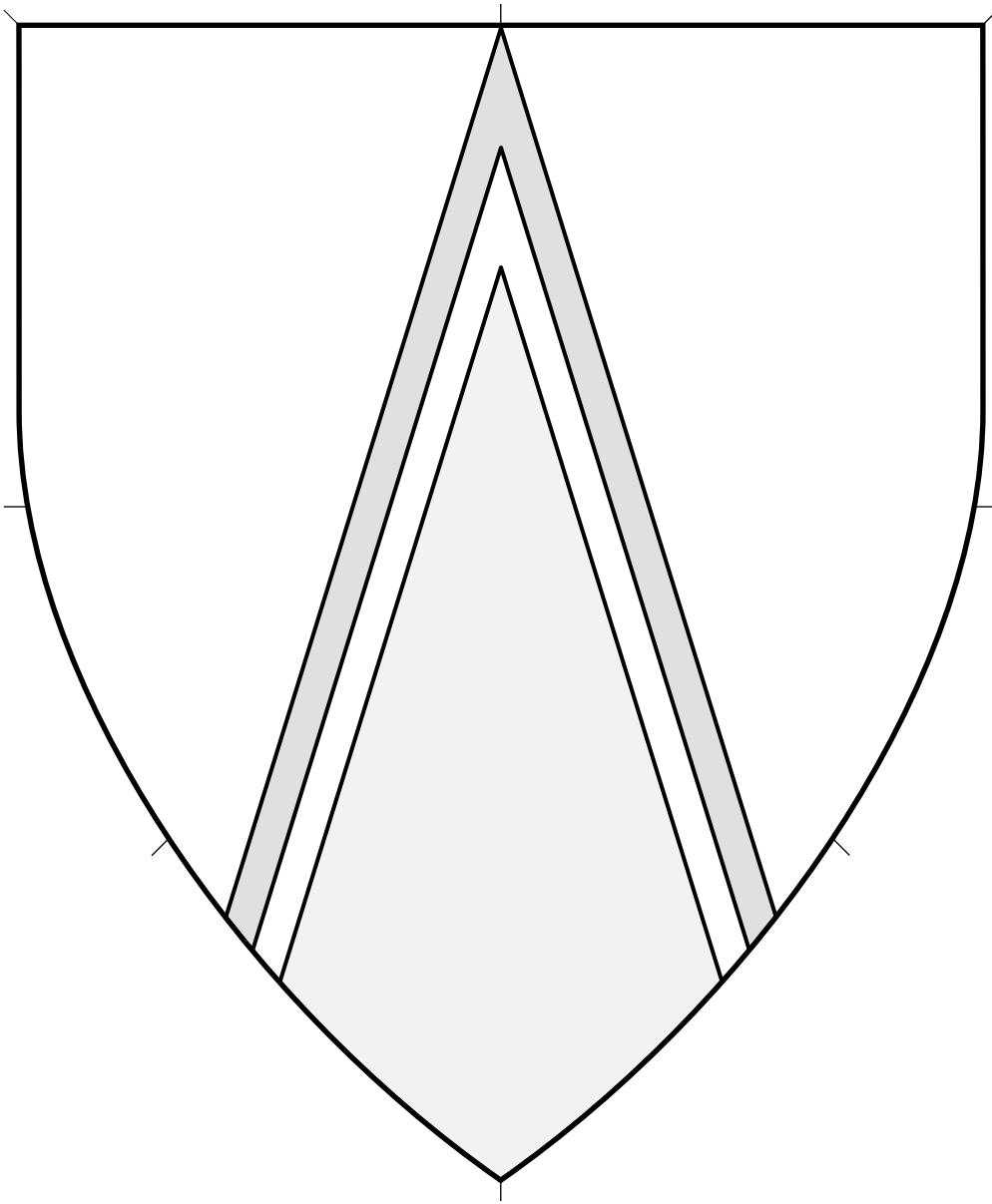

Central ordinary.

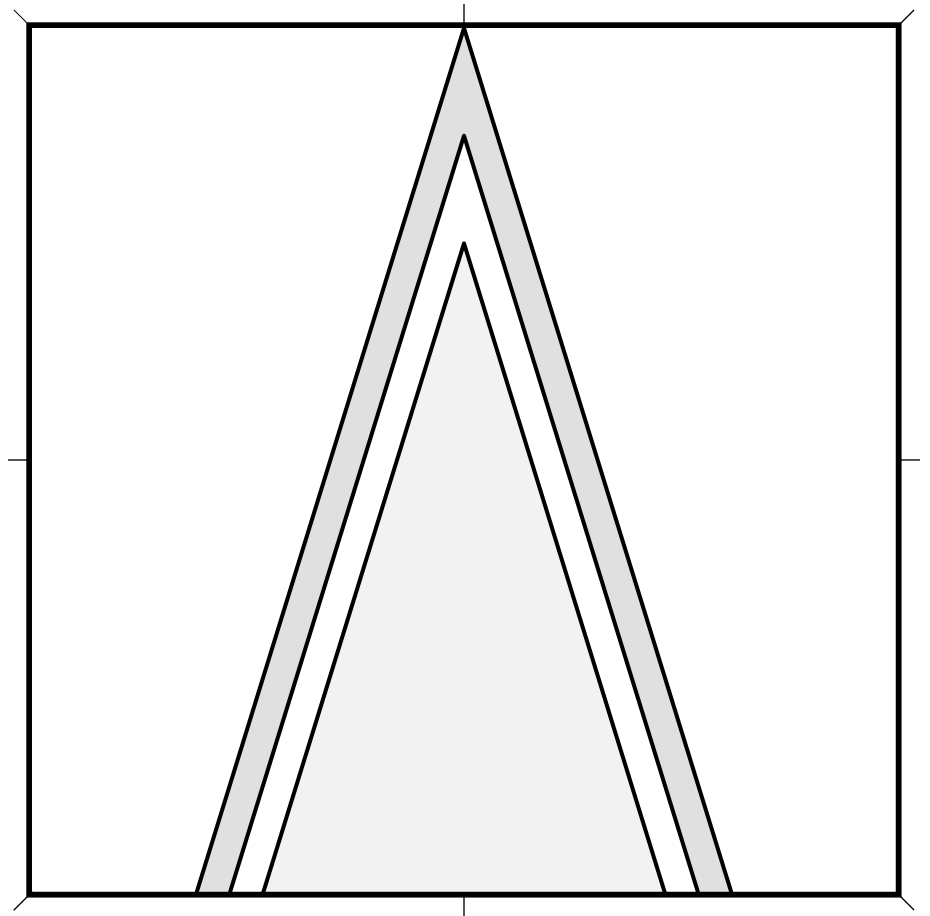

Pile Inverted Cotised 4.549

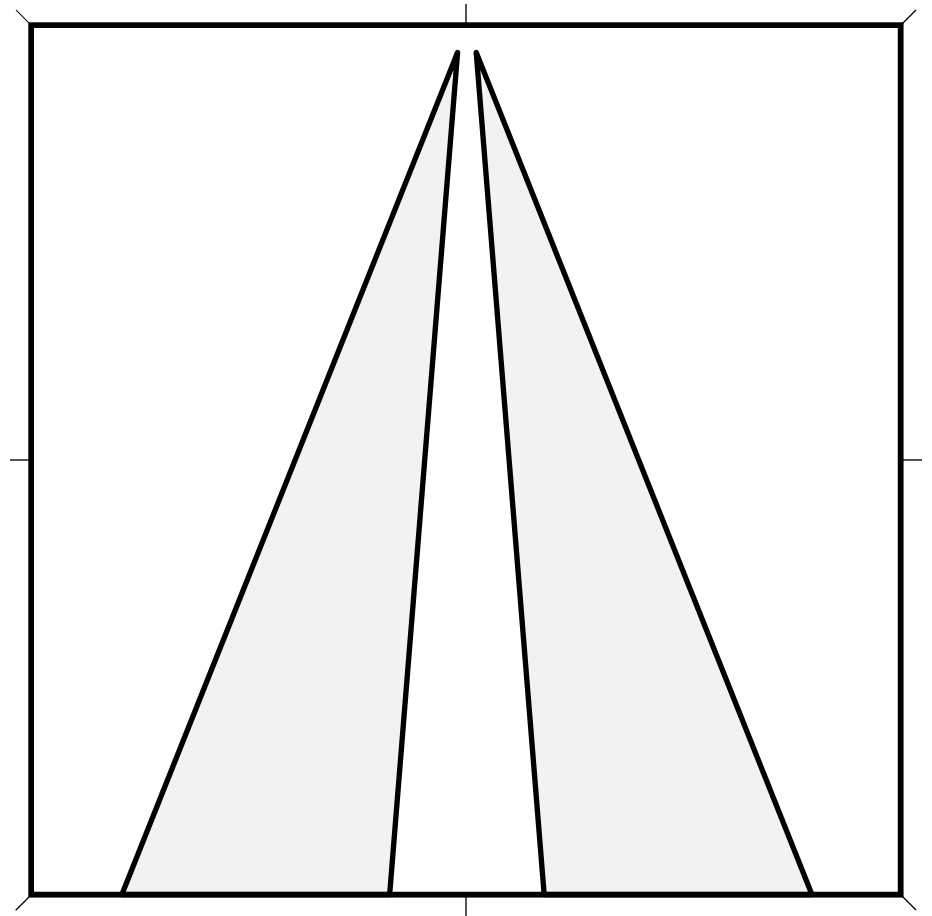
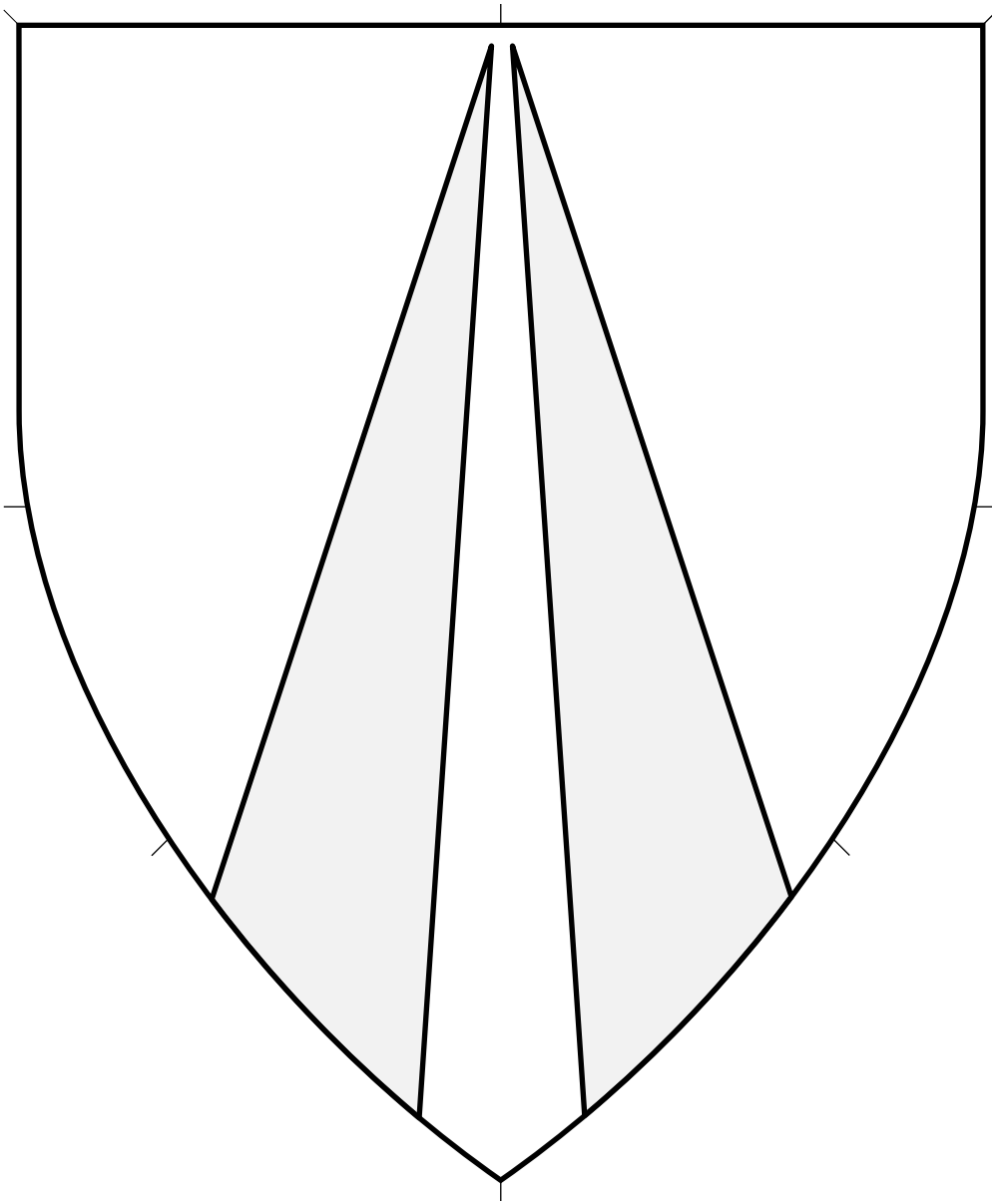

Central ordinary.
May be throughout, reaching the chief, or not.

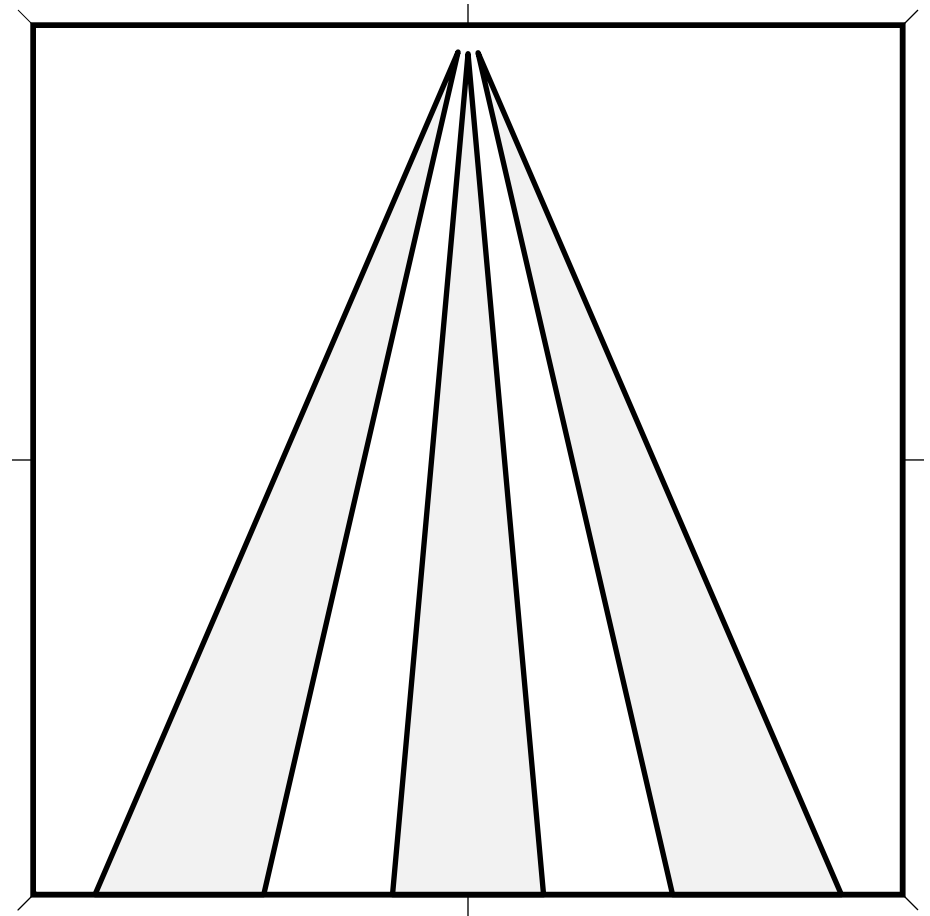
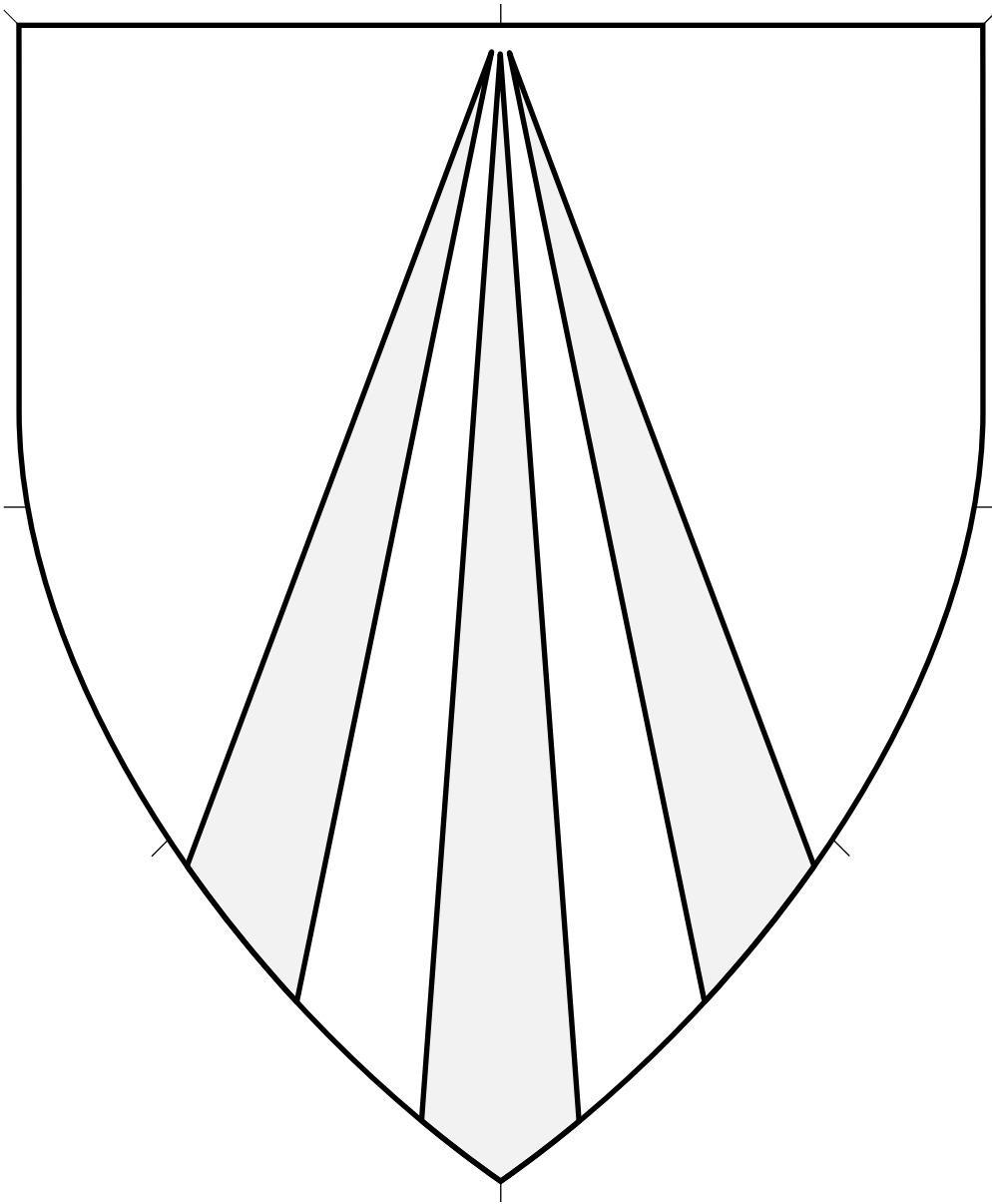

Central ordinary.
May be throughout, reaching the chief, or not.

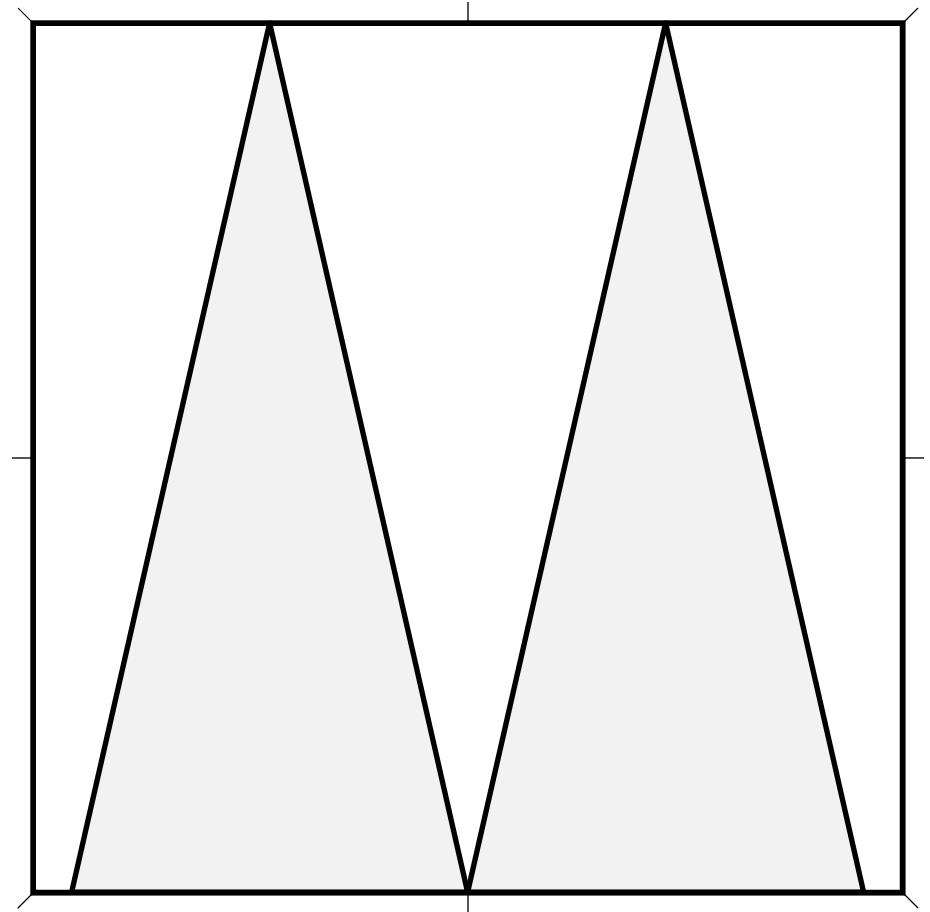
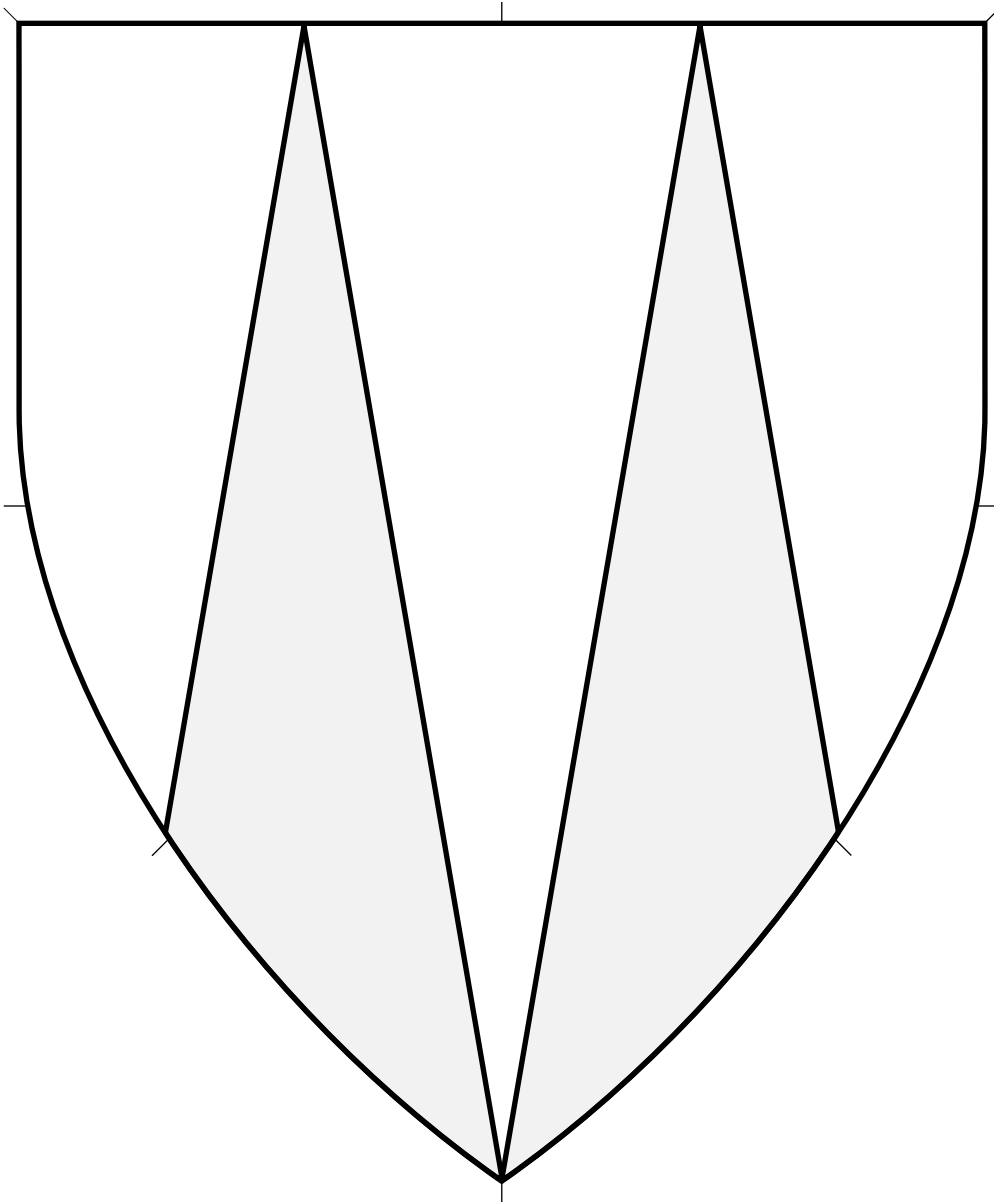

Central ordinary.

May be throughout, reaching the chief edge, or not.

Source: Des Kaiserlichen Kammergerichts
zu Speier Kammerrichter. Artist unknown. (Page 75.)

Piles Inverted Palewise, 2 4.552

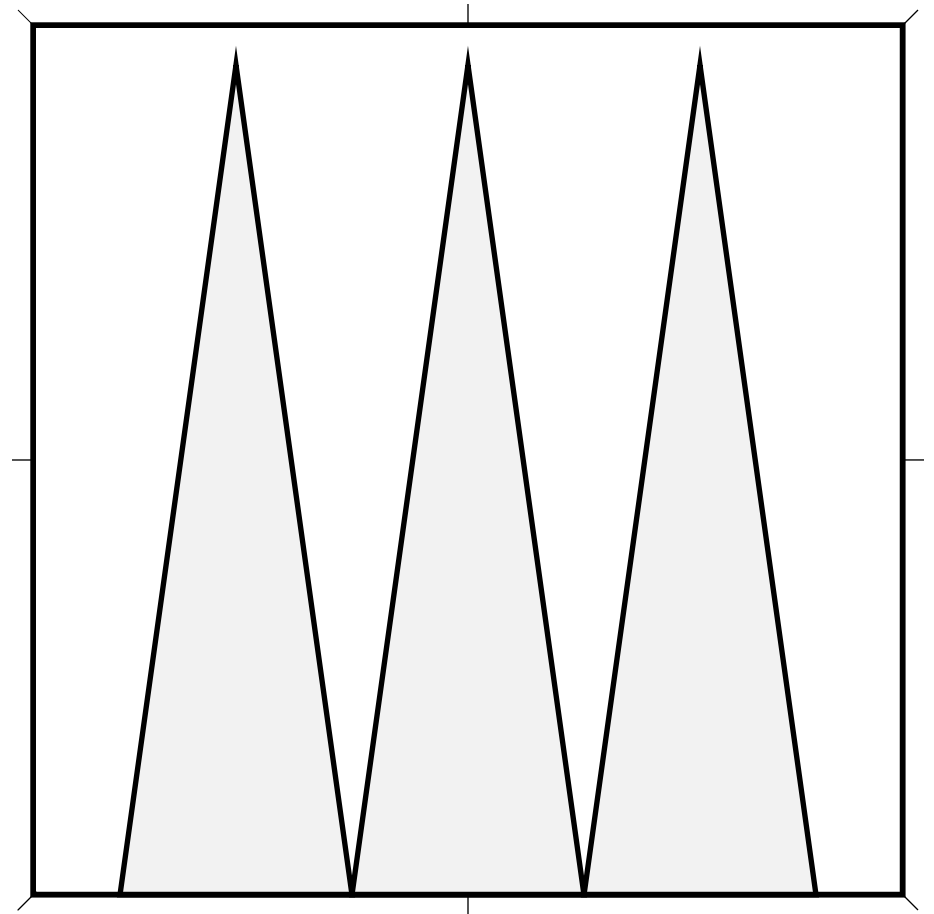
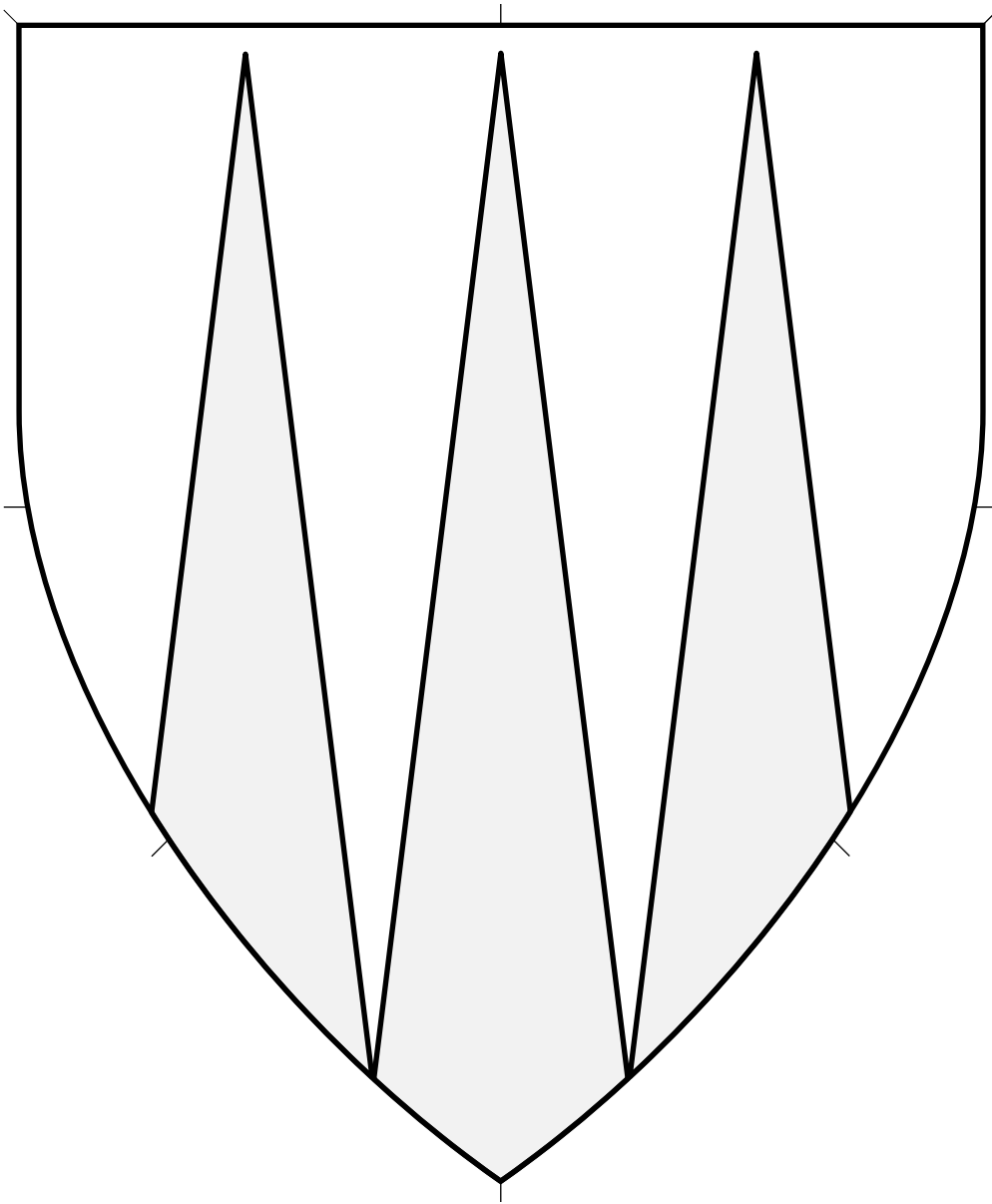

Central ordinary.
May be throughout, reaching the chief edge, or not.

Piles Inverted Palewise, 3 4.553

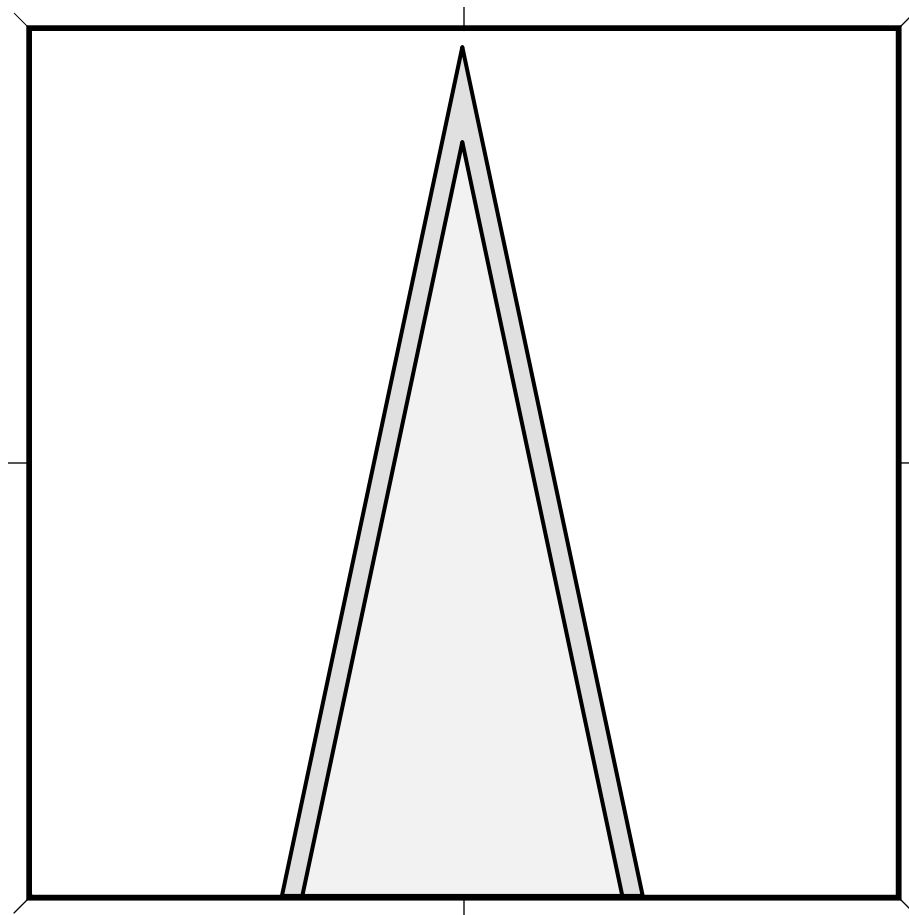
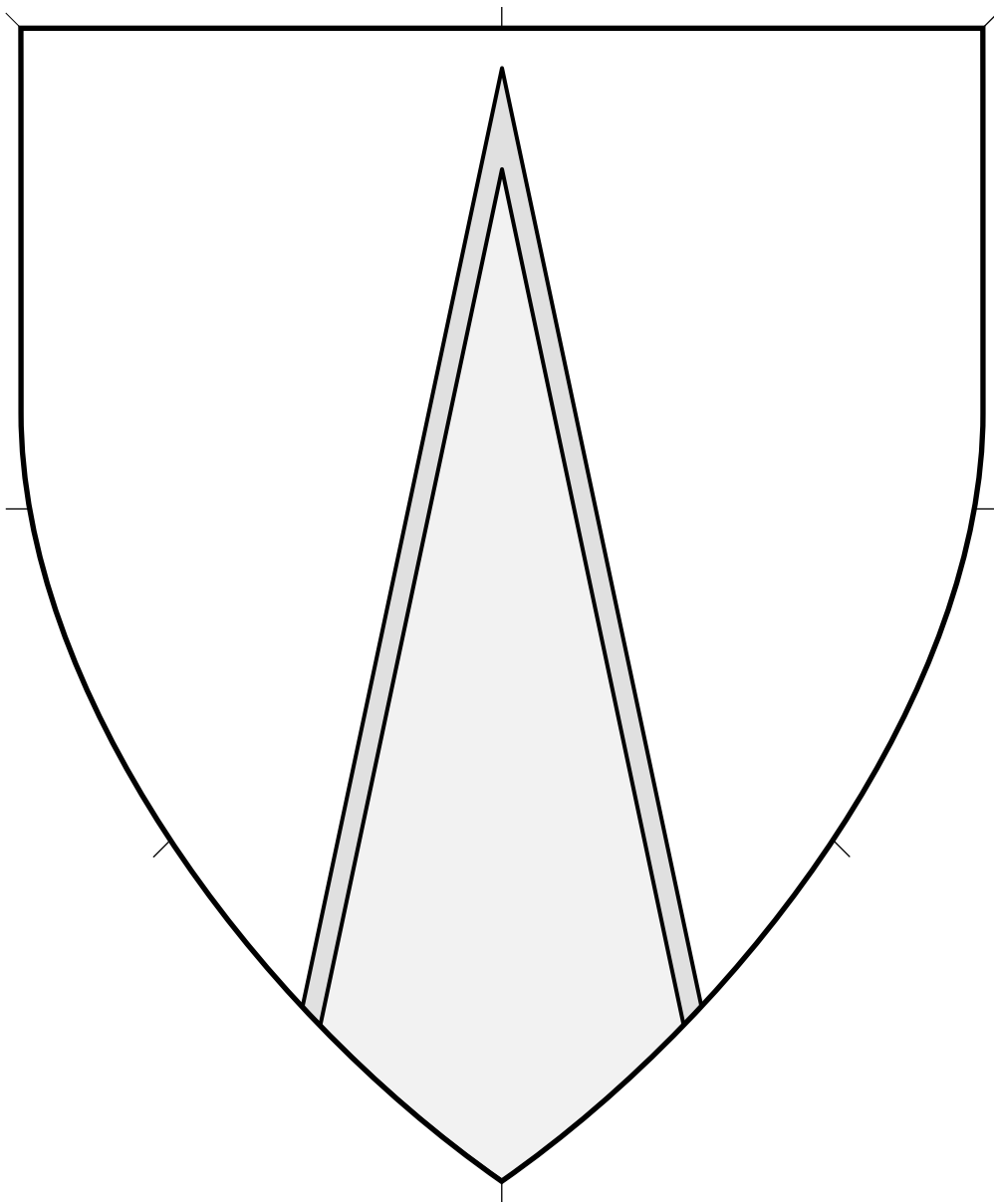

Central ordinary.
Artist: Vémundr Syvursson.

Pile Inverted Fimbriated (1) 4.554

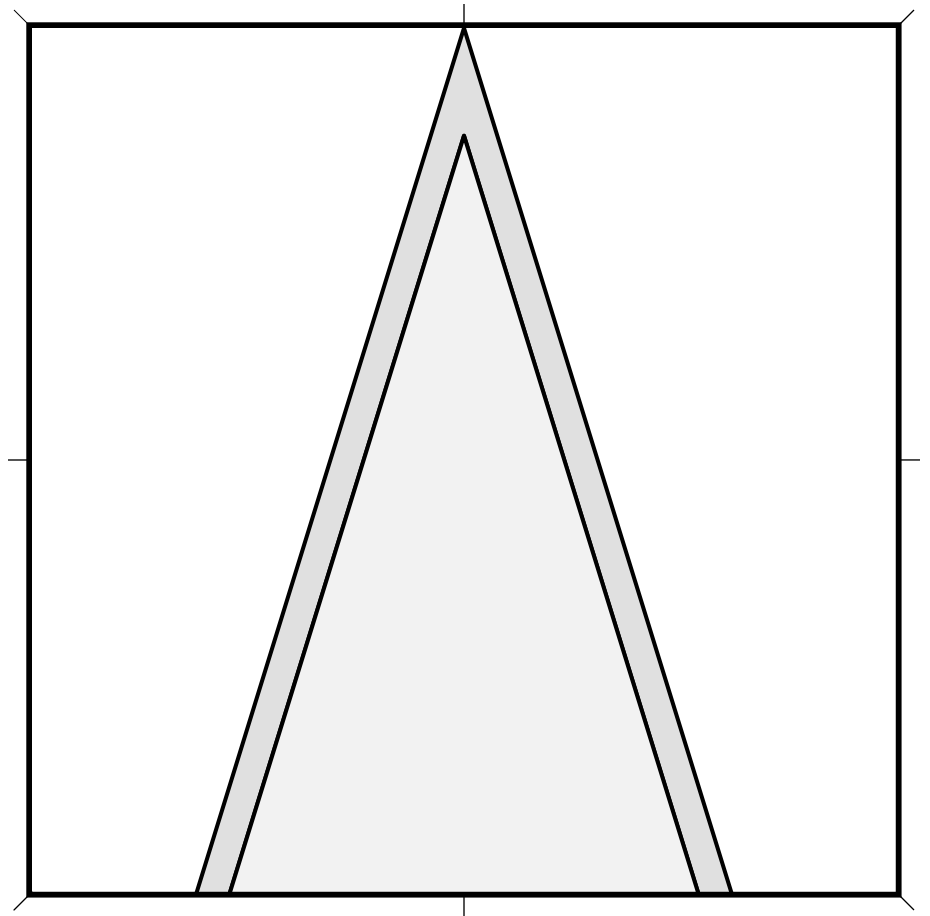
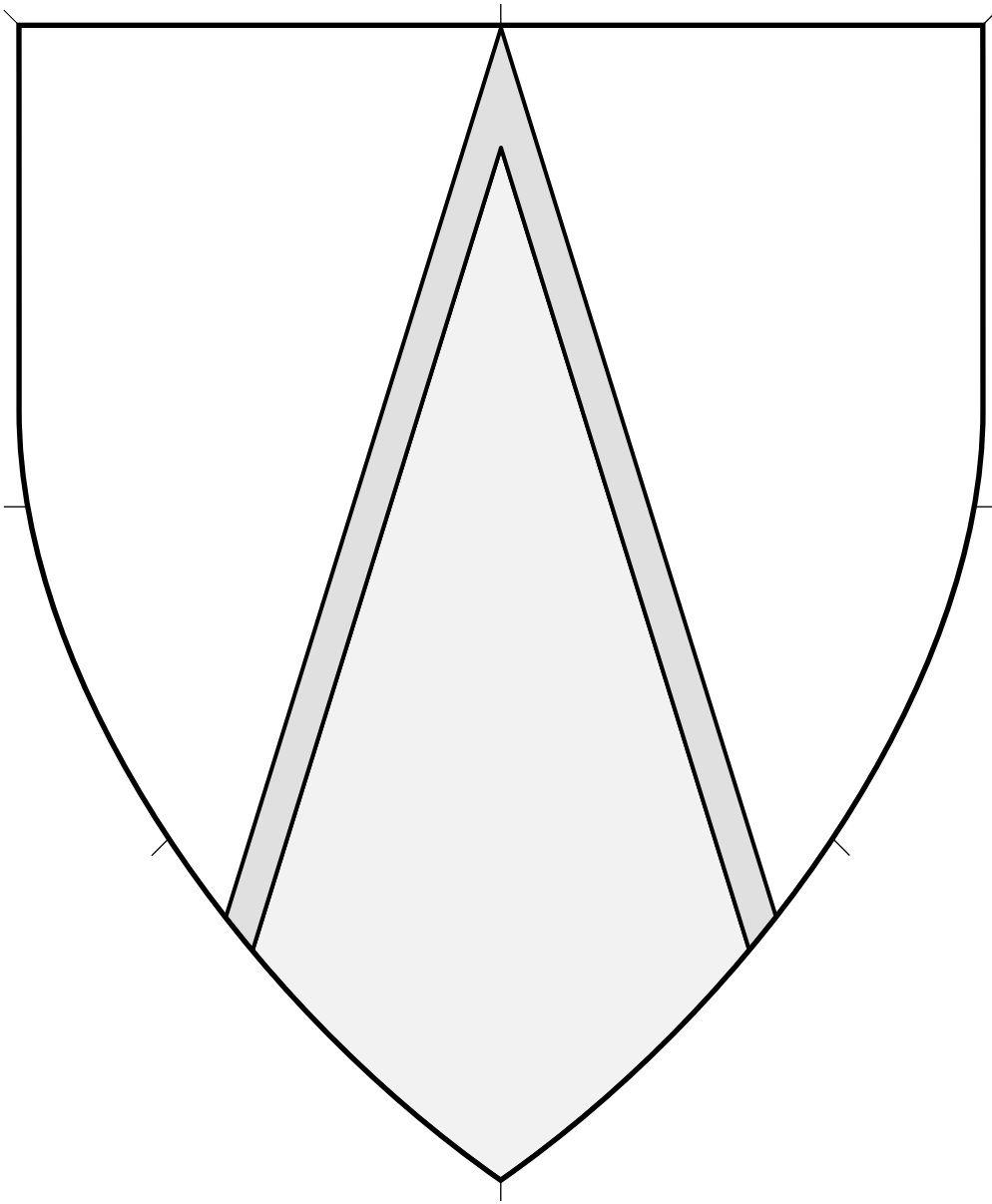

Central ordinary.

Pile Inverted Fimbriated (2) 4.555

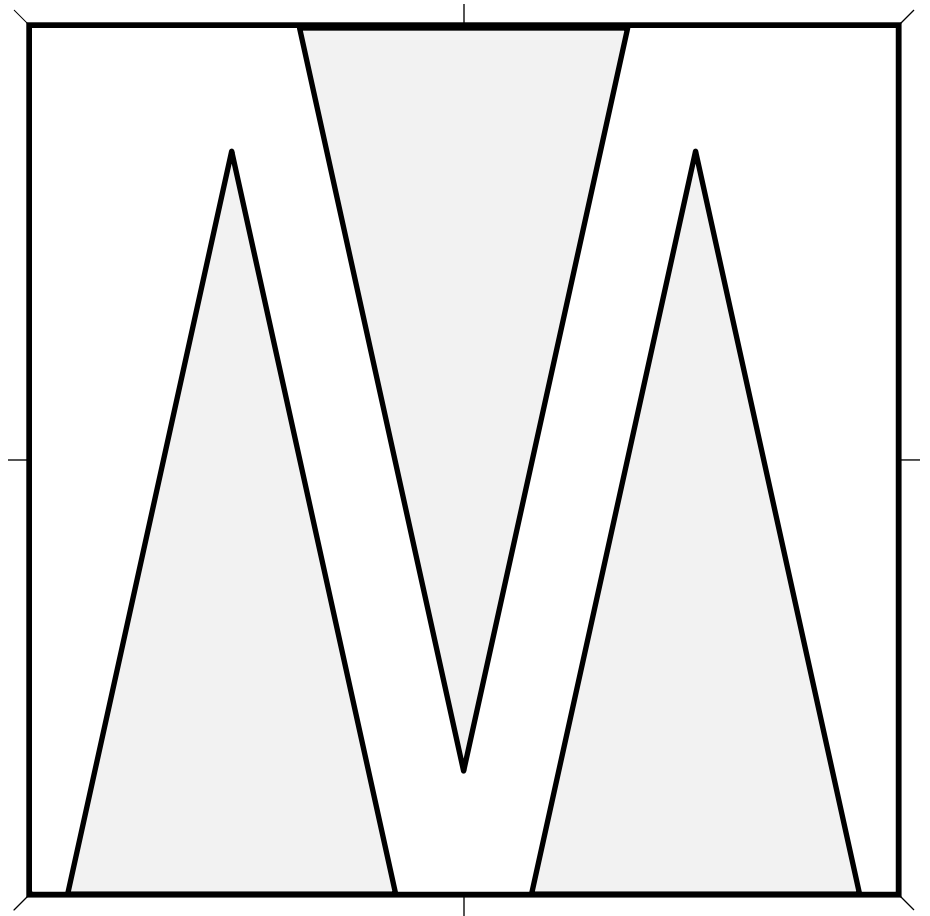
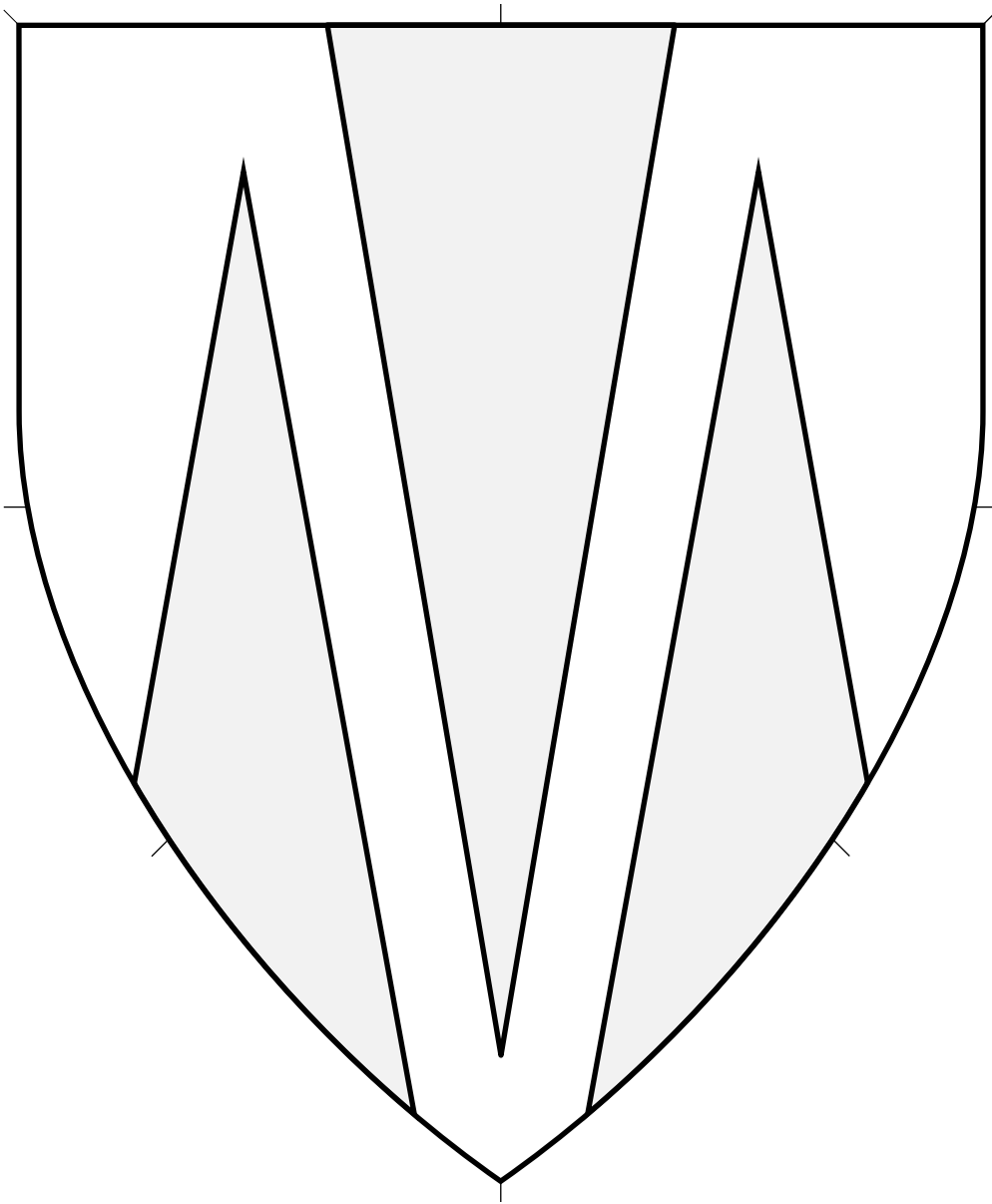

Central ordinary.

Source: A System of Heraldry.
Artist unknown. (Page 199.)

Pile Between Two Piles Inverted 4.556

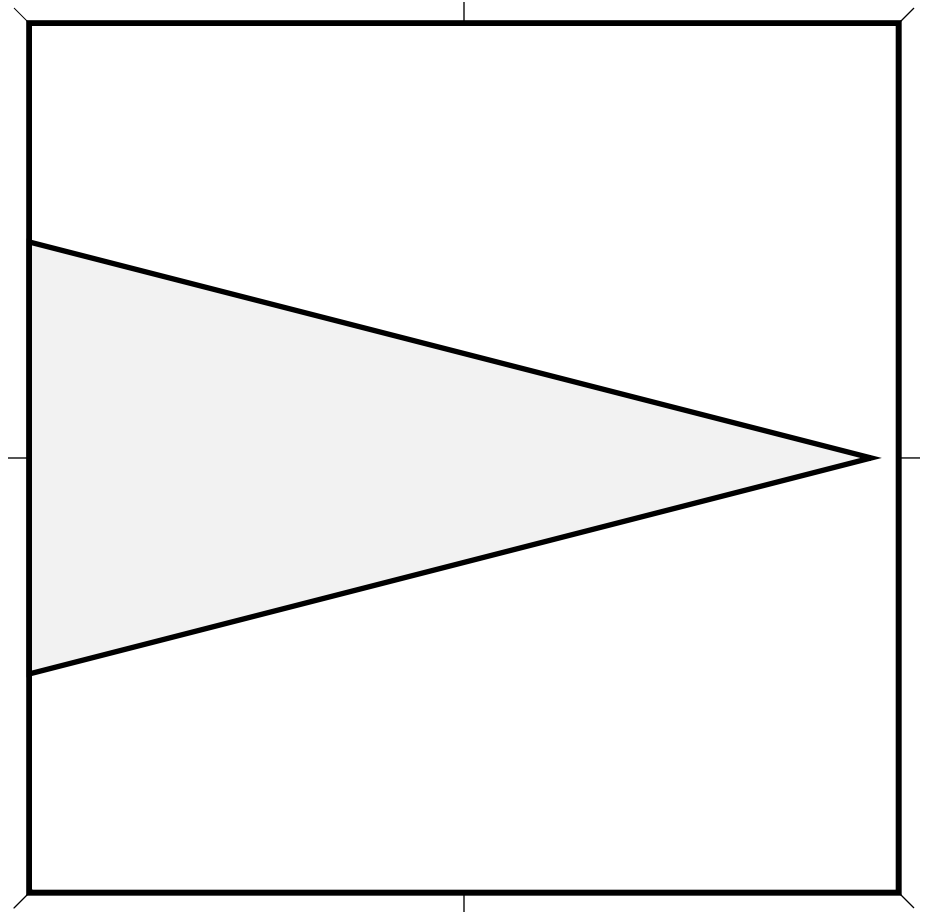
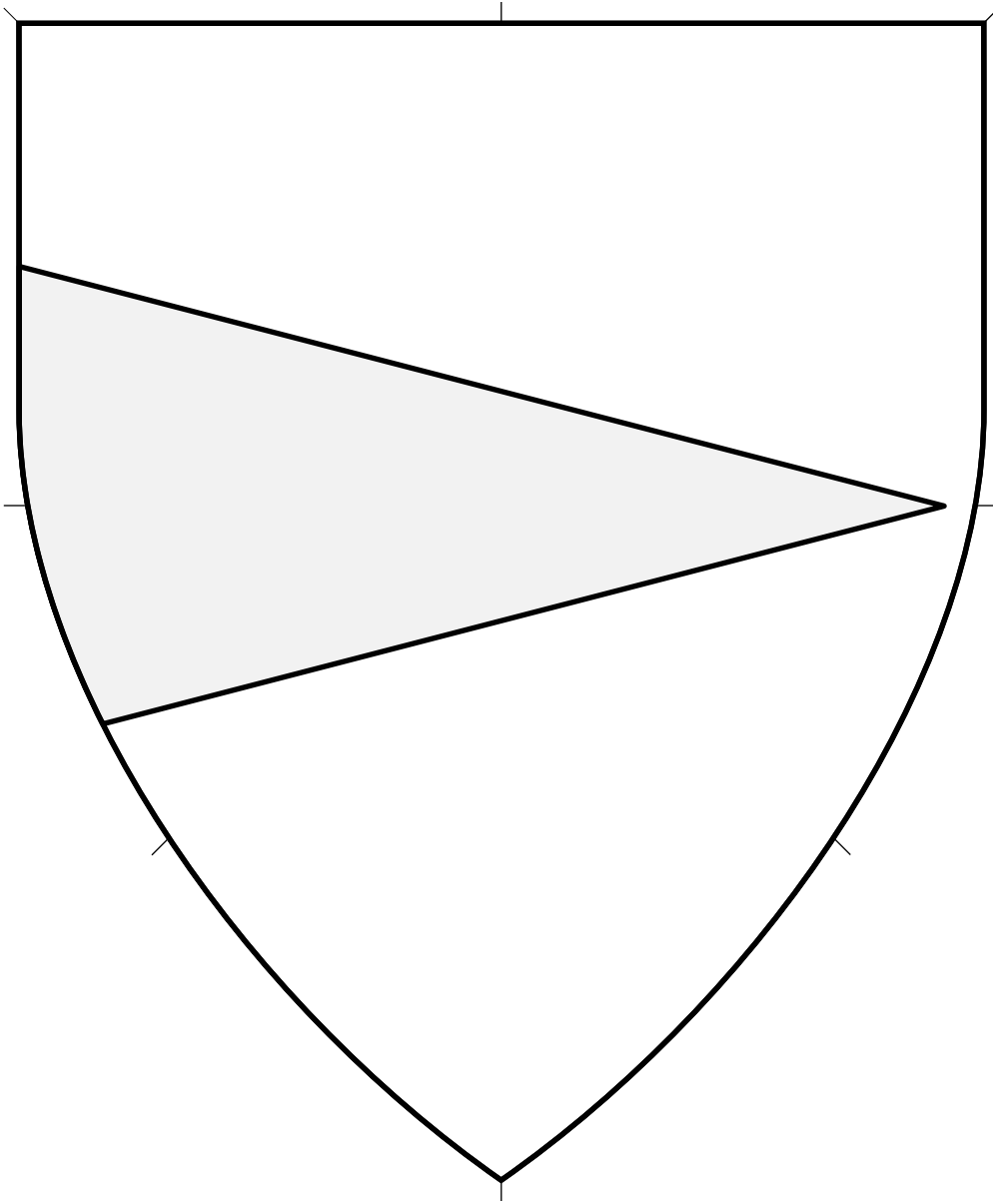

Central ordinary.

Pile Issuant From Dexter 4.557

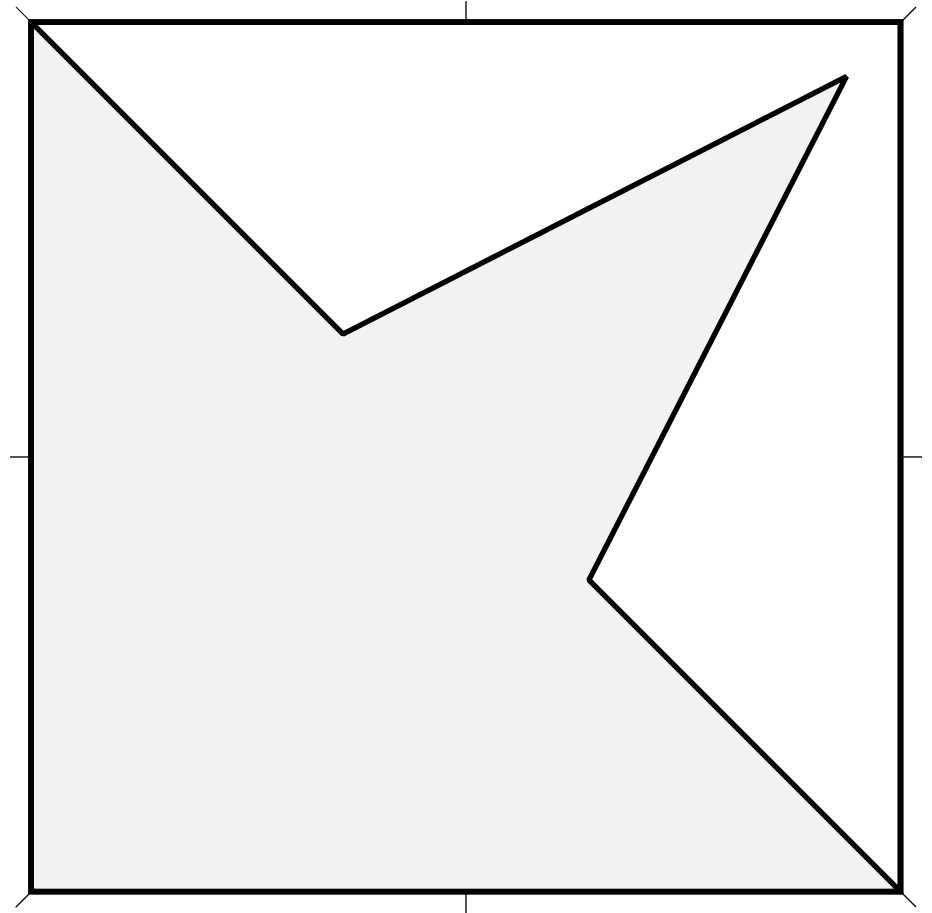
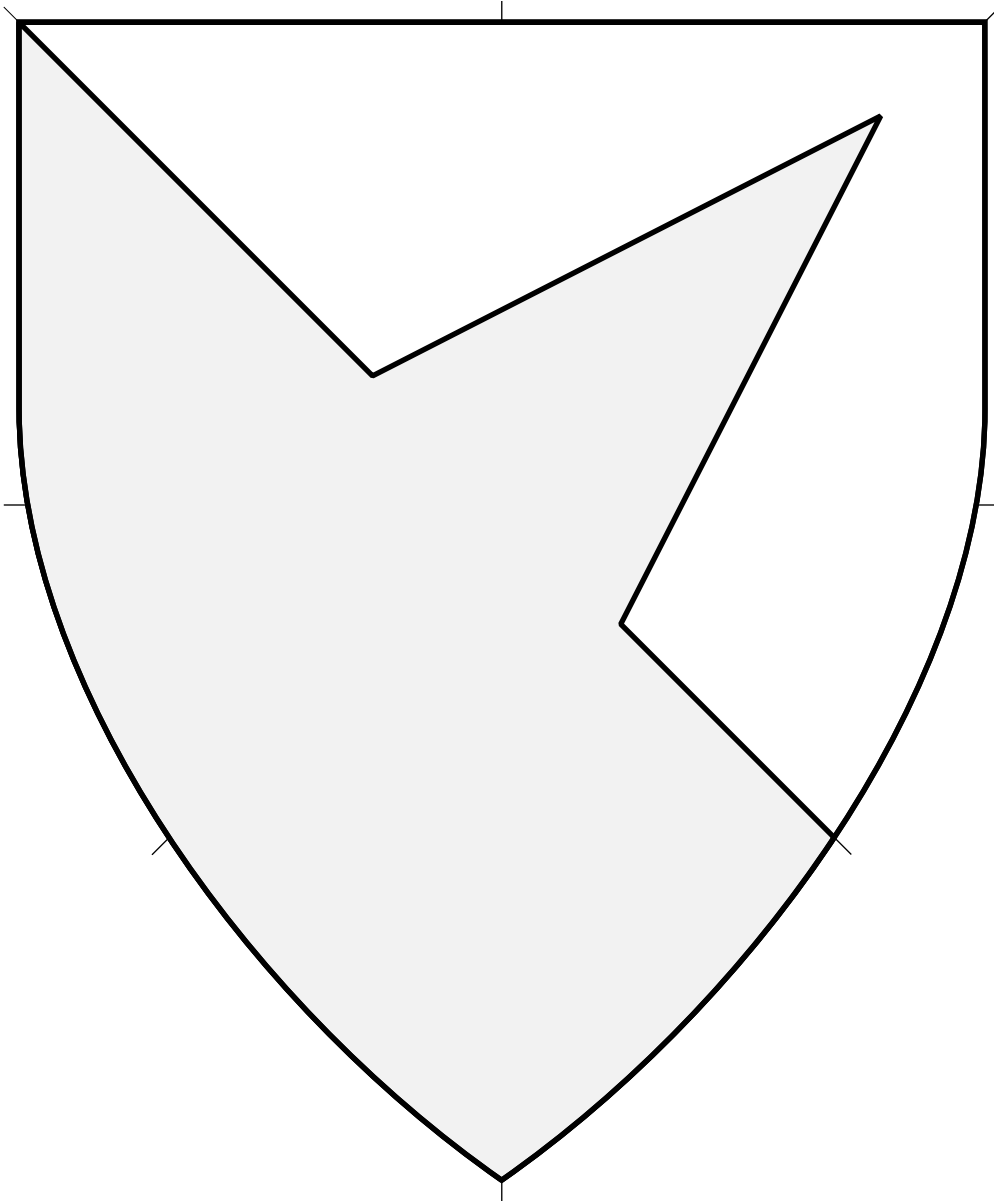

Field division and central ordinary.

Source: St. Gallen Armorial.
Artist unknown. (Page 206.)

Pile Issuant from the Line, Per Bend A 4.558

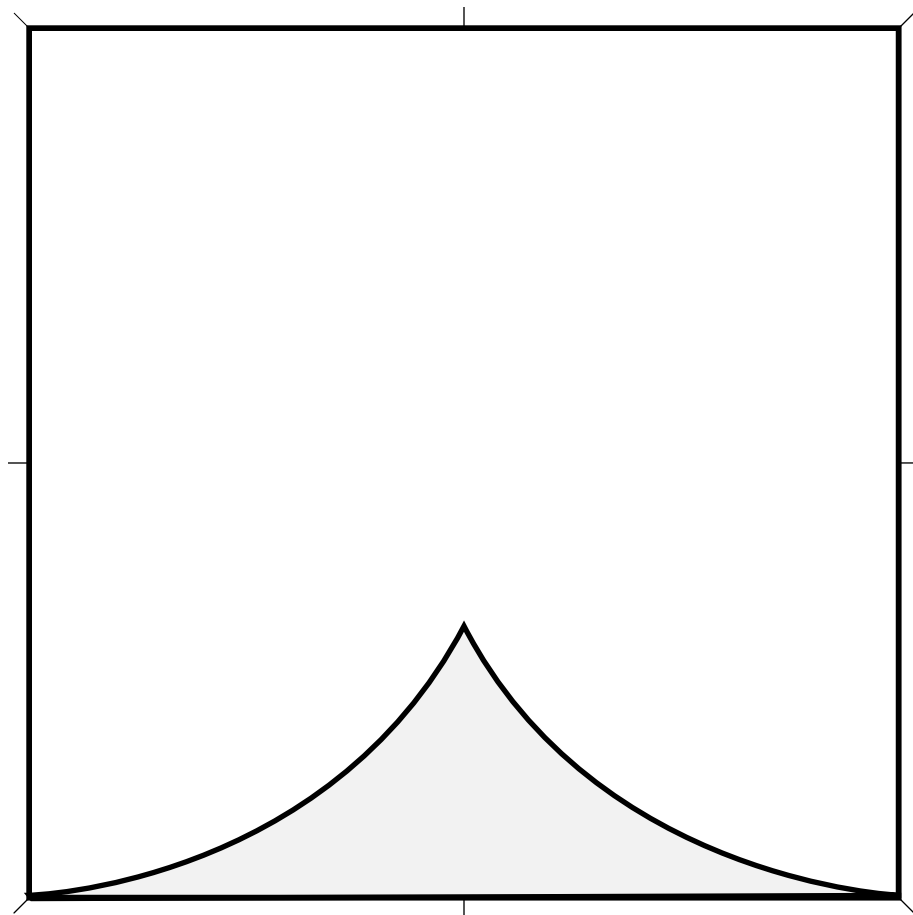
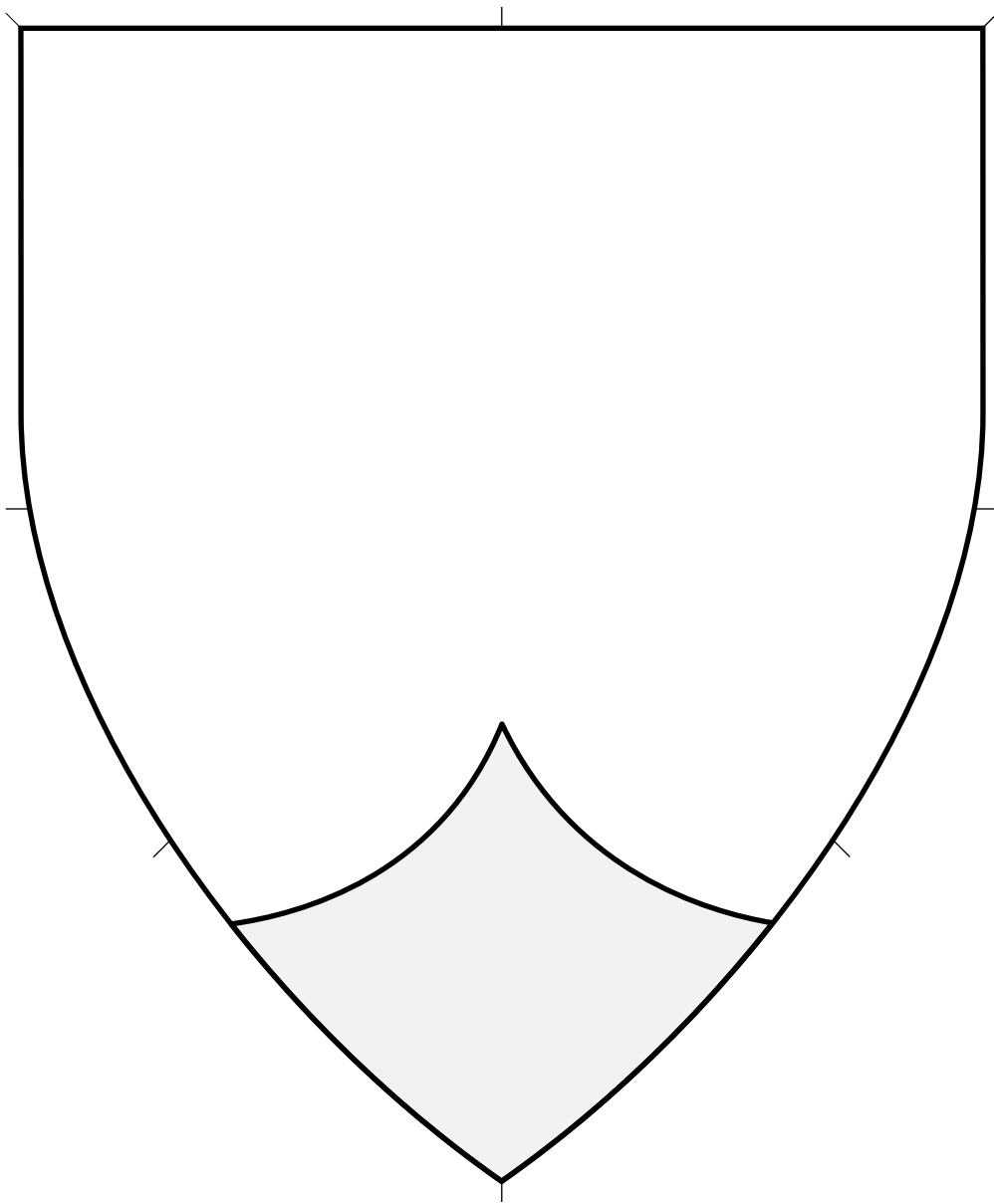

Peripheral ordinary.

May be drawn with curved or straight sides; this version with curved sides is more typical in period.

Point Pointed (1) 4.559

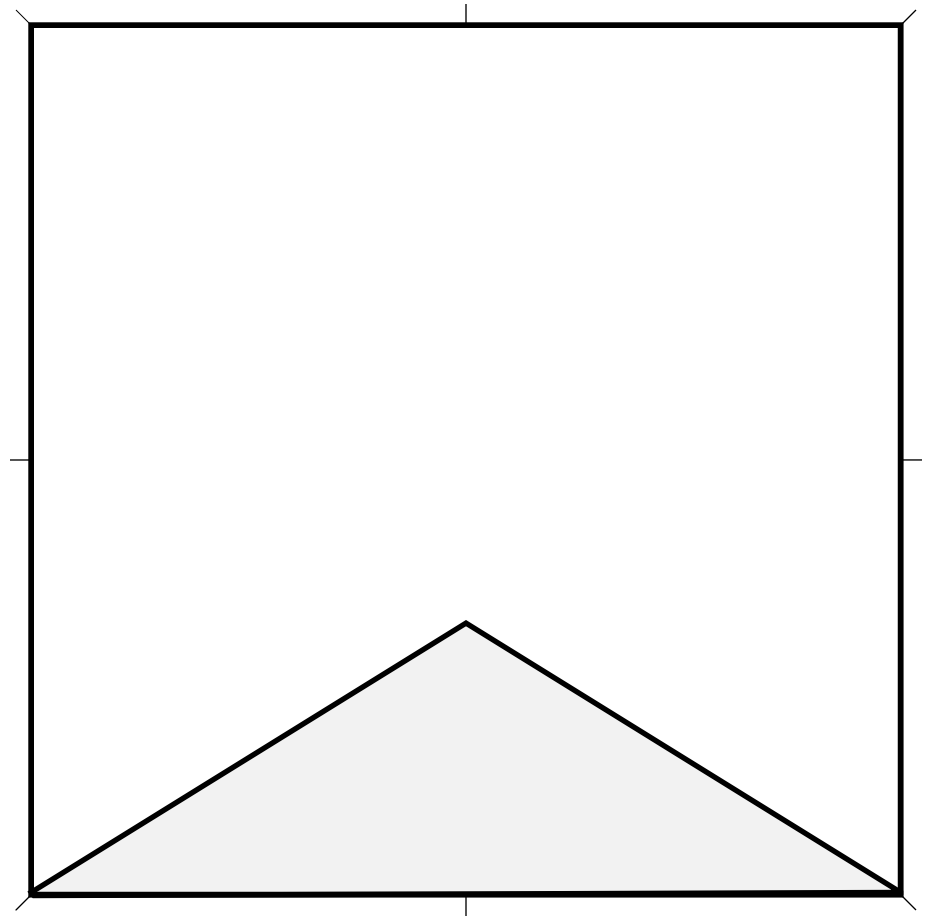
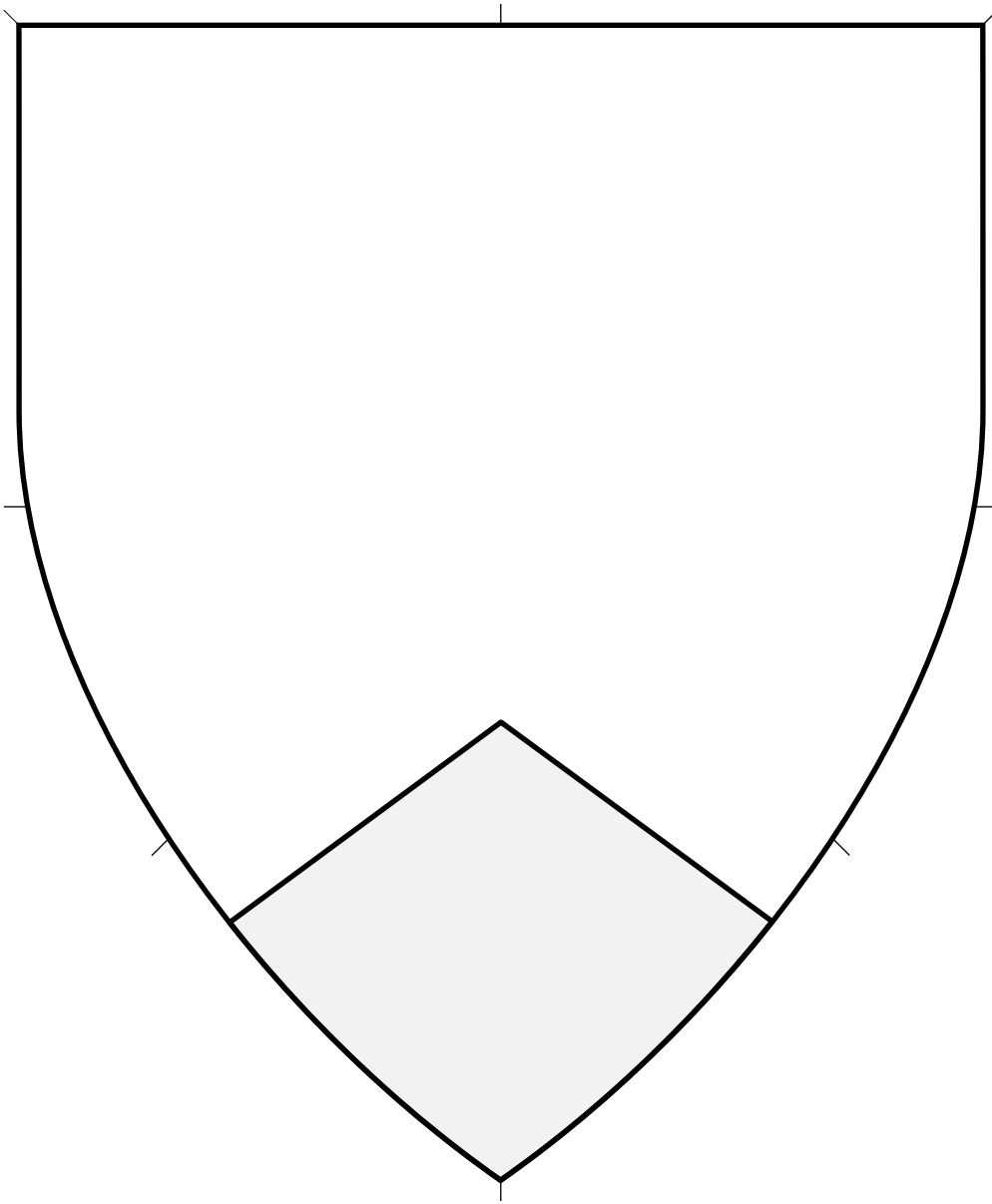

Peripheral ordinary.

May be drawn with curved or straight sides; this version with straight sides is rare in period.

Point Pointed (2) • 4.560

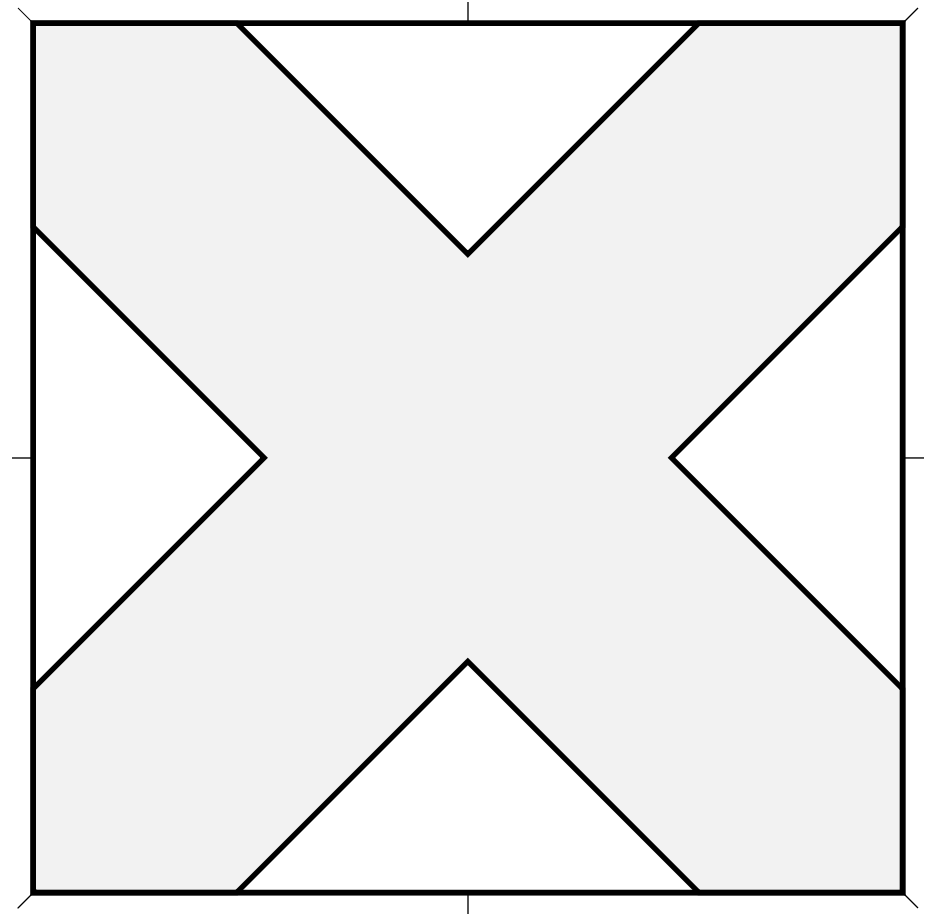
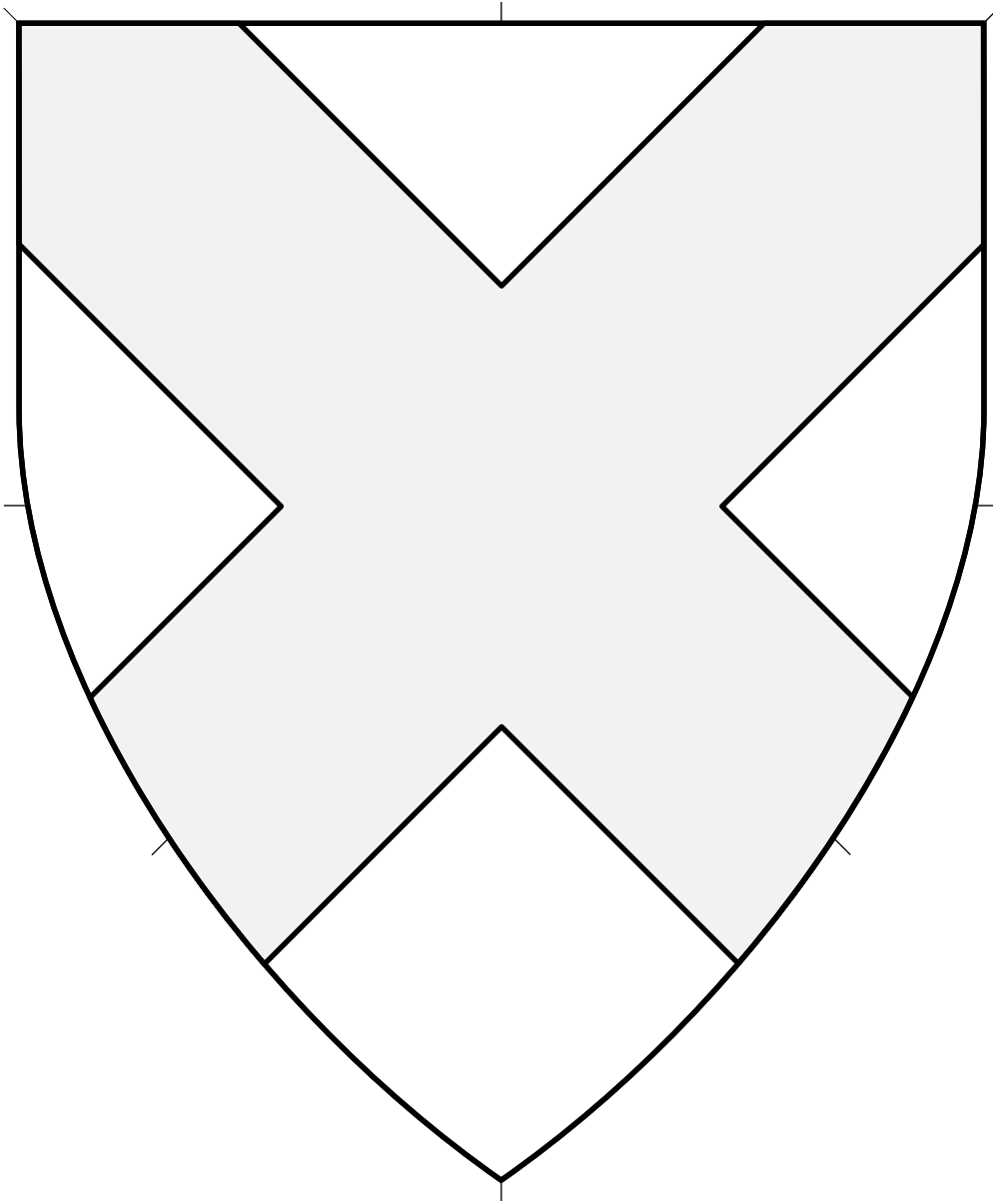

Central ordinary. The width may be a third of the width of the device or a bit narrower. This a thick saltire.

Sometimes blazoned a "St. Andrew's cross."

Saltire (1) 4.561

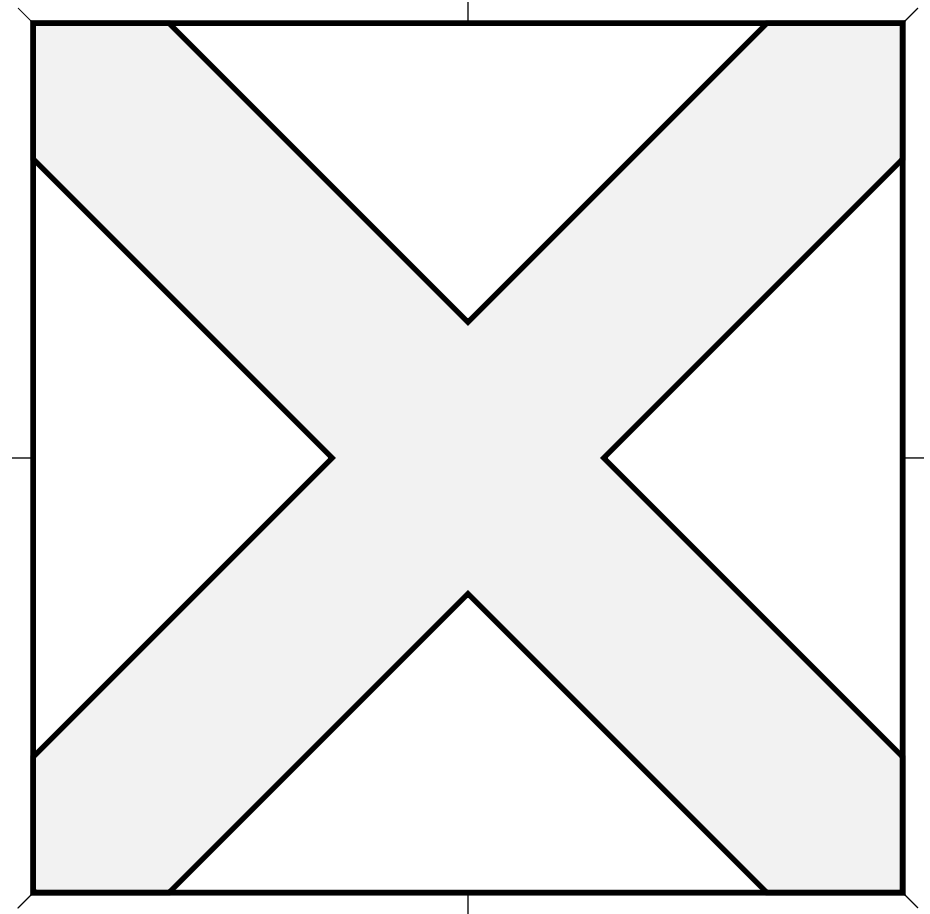
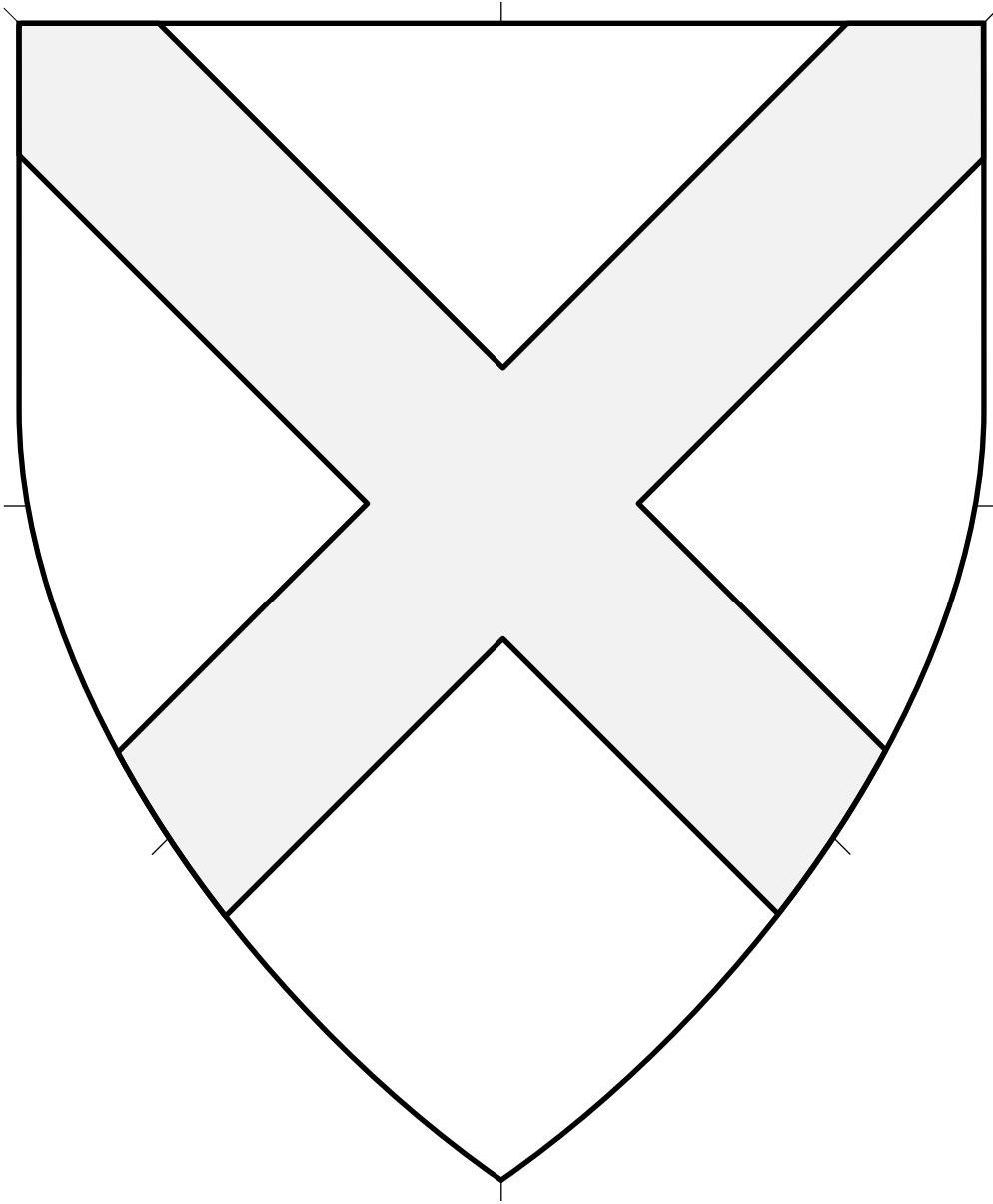

Central ordinary. The width may be a third of the width of the device or a bit narrower. This a thin saltire.

Sometimes blazoned a "St. Andrew's cross."

Saltire (2) 4.562

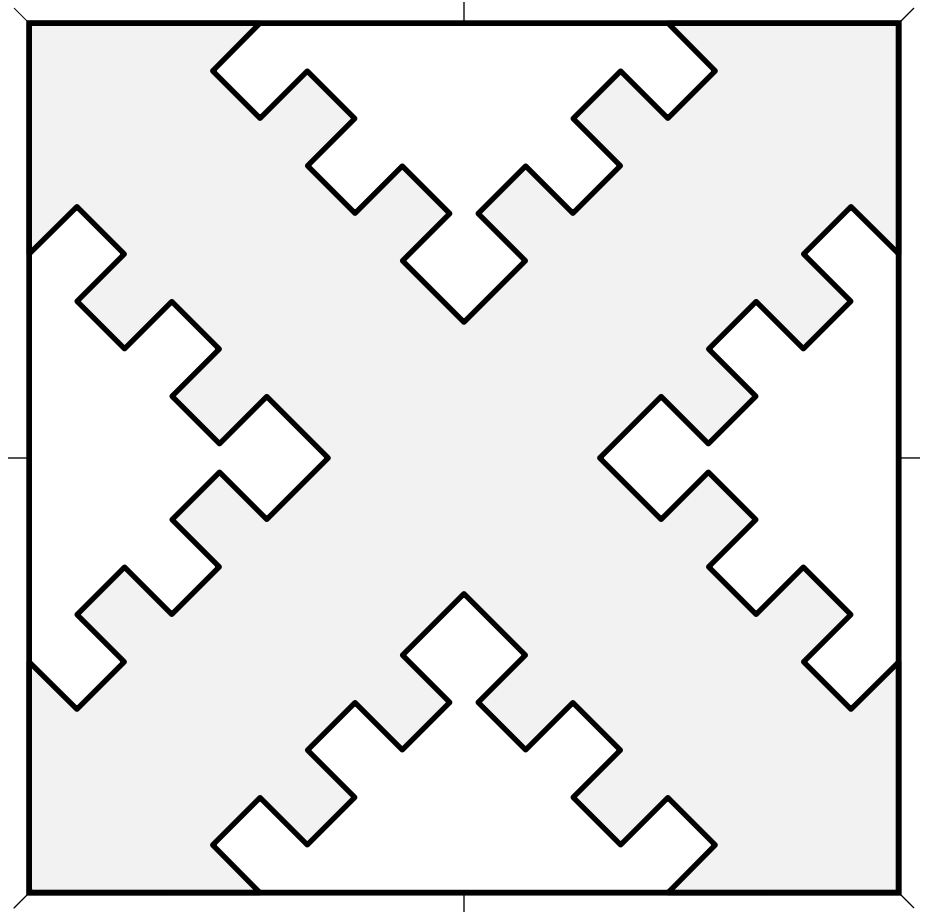
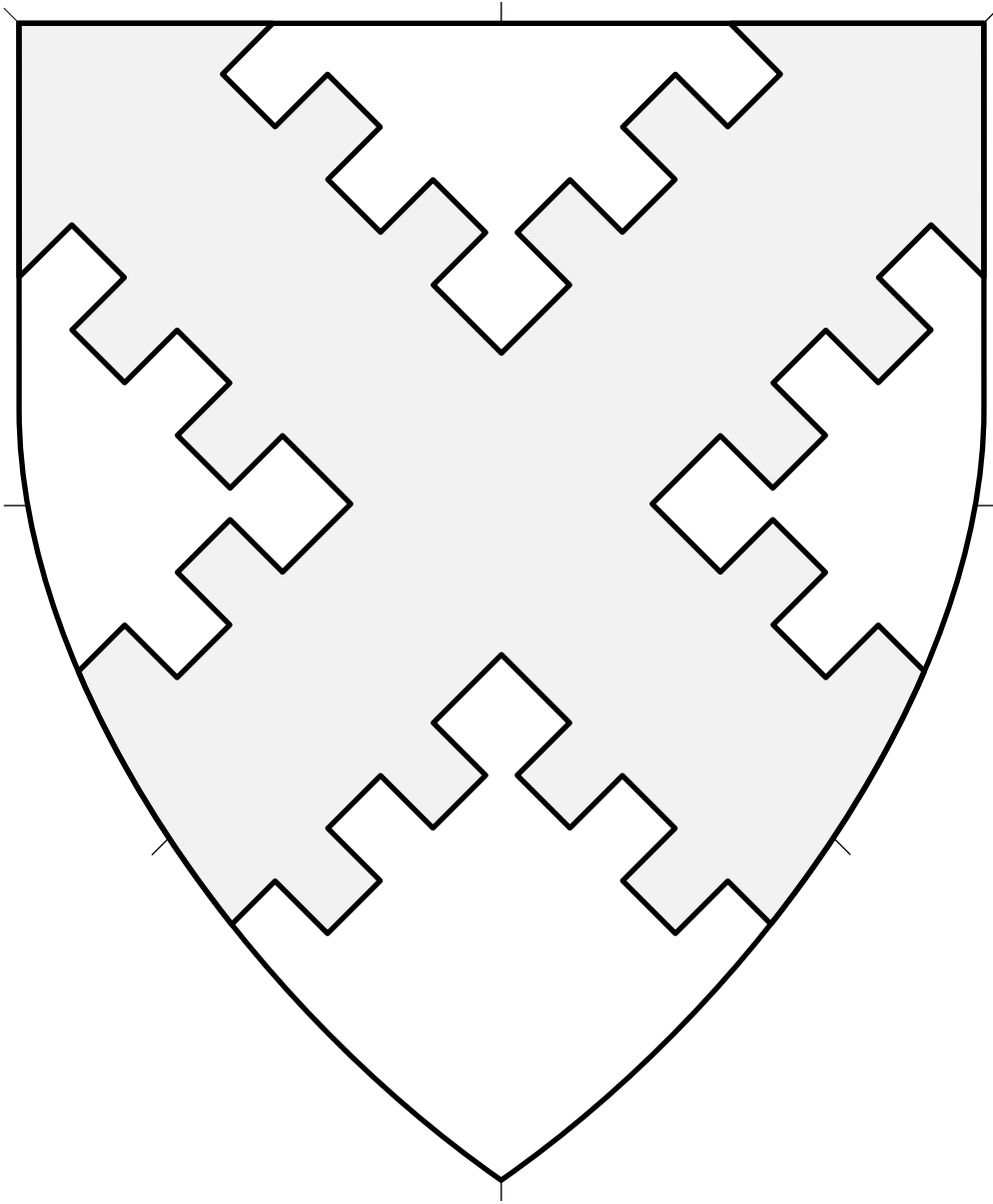

Central ordinary.

Saltire Bretesse 4.563

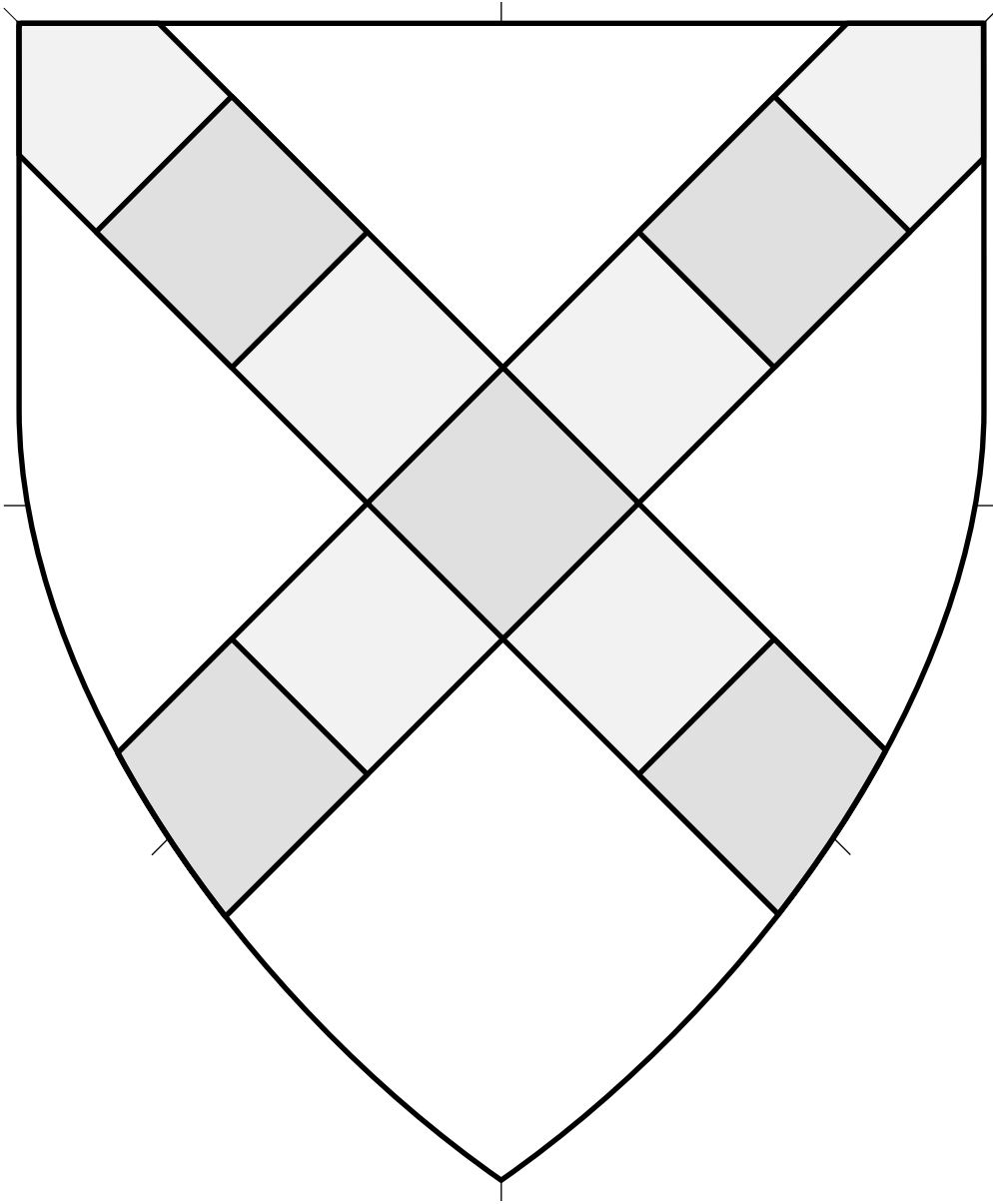

Central ordinary.

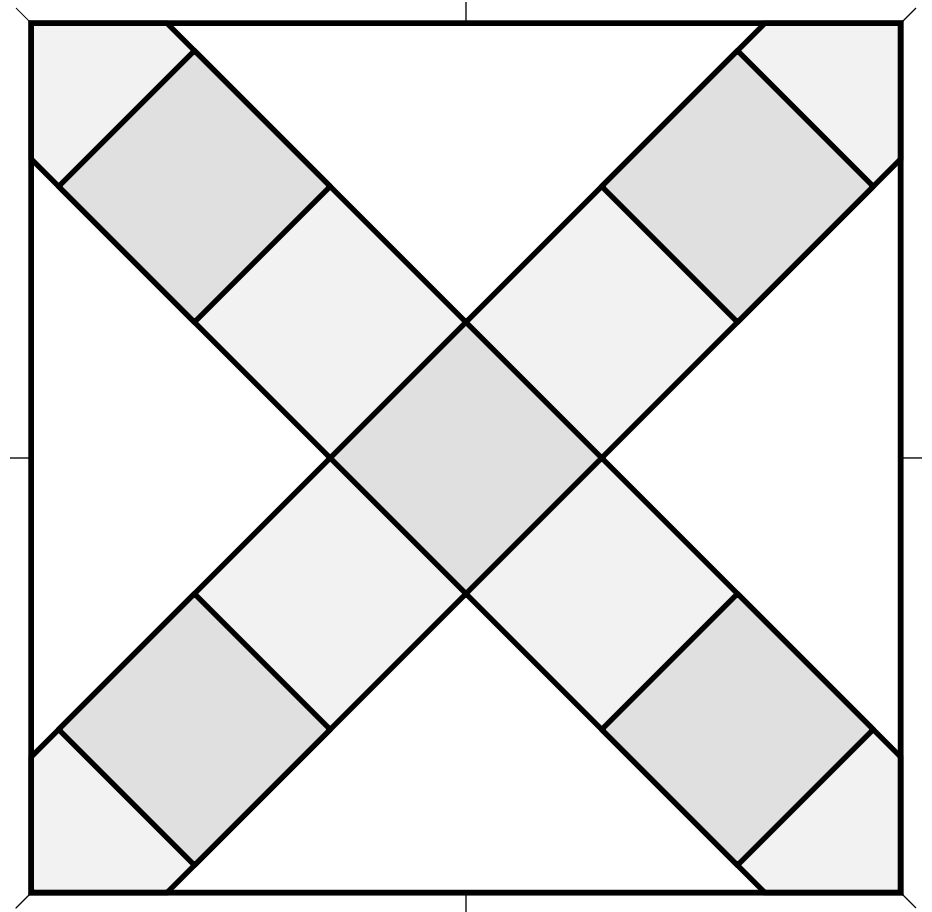

Saltire Compony (1) 4.564

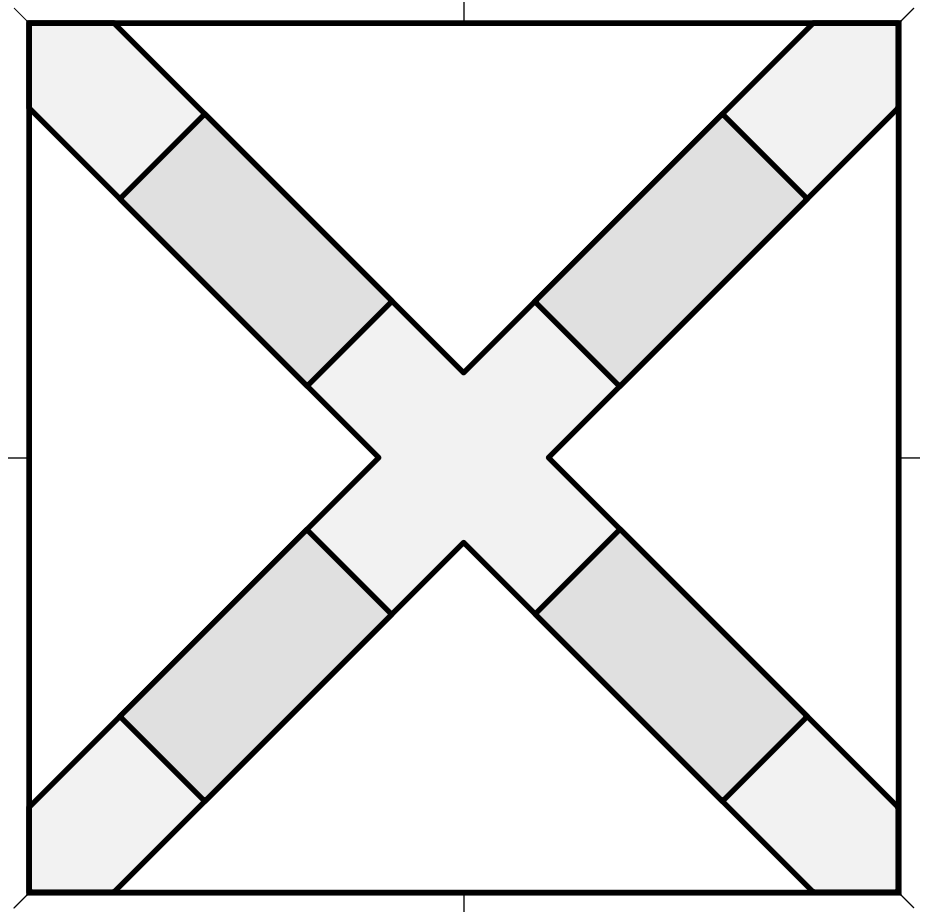
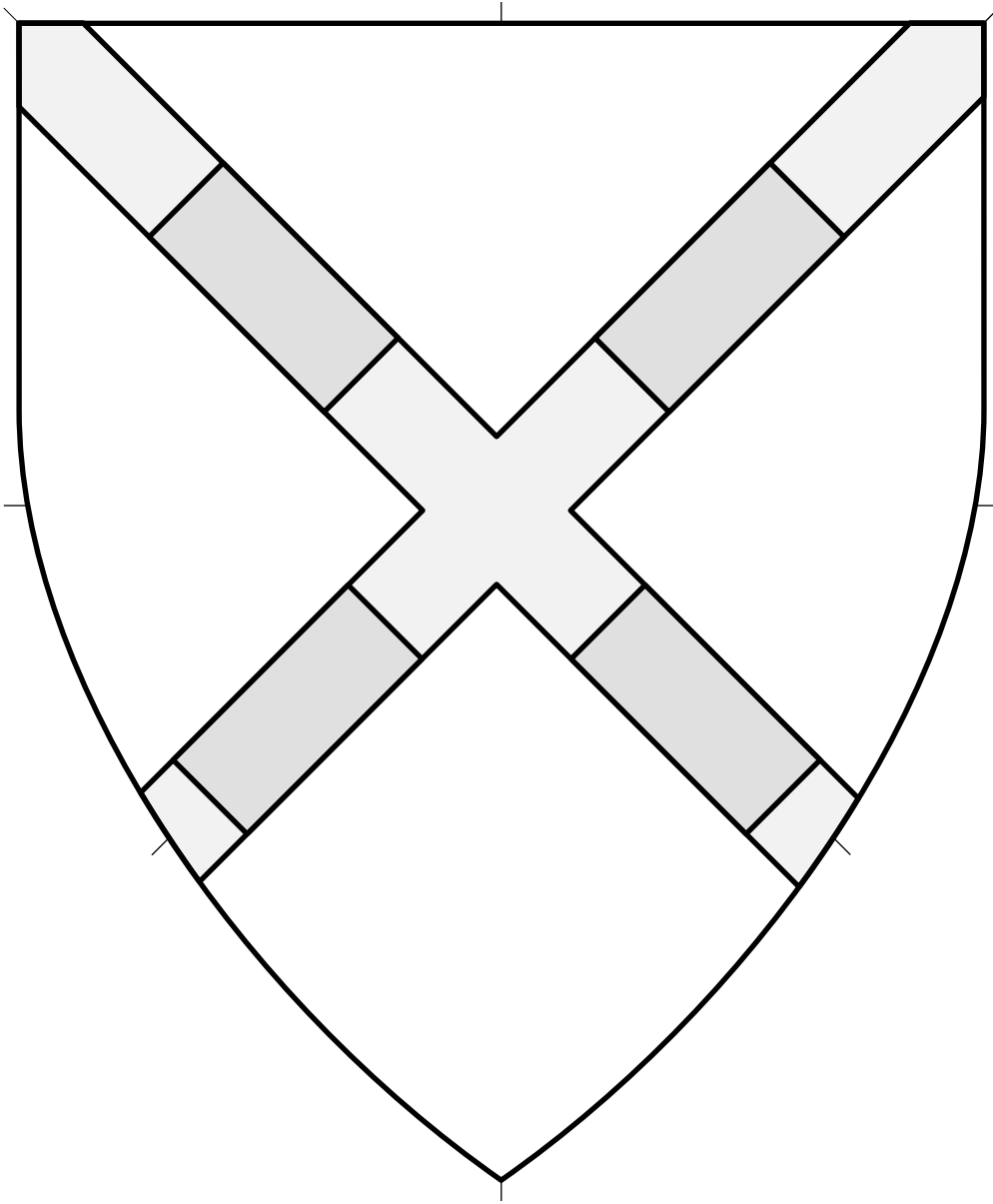

Central ordinary.

Source: BnF MS Allemand 304. Artist unknown. (Page 573.)

Saltire Compony (2) 4.565

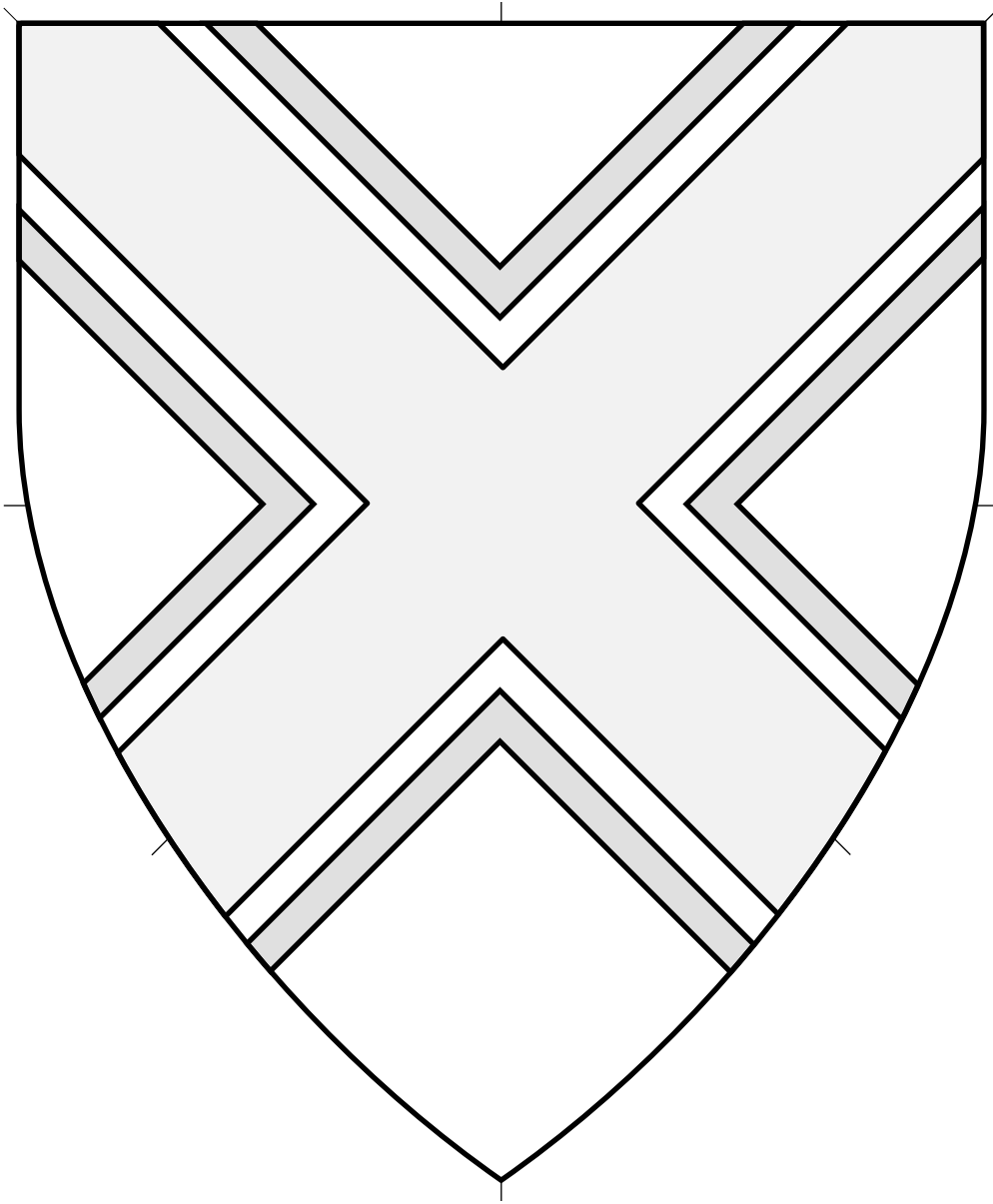

Central ordinary.

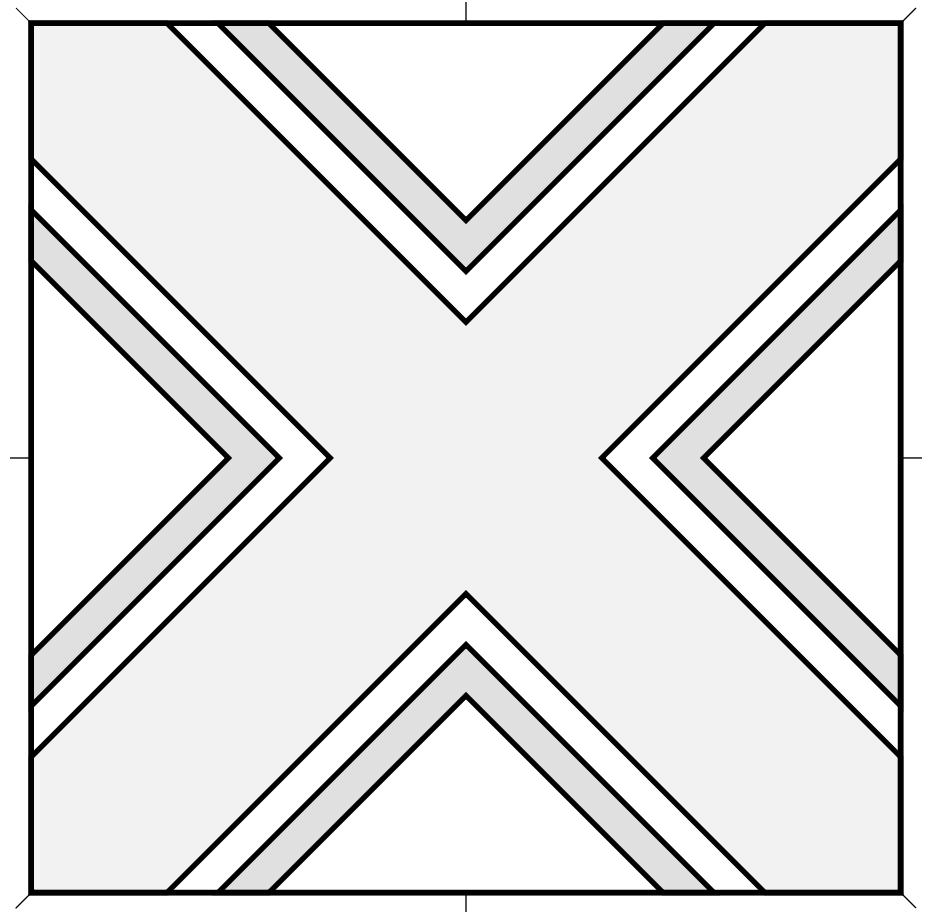

Saltire Cotised • 4.566

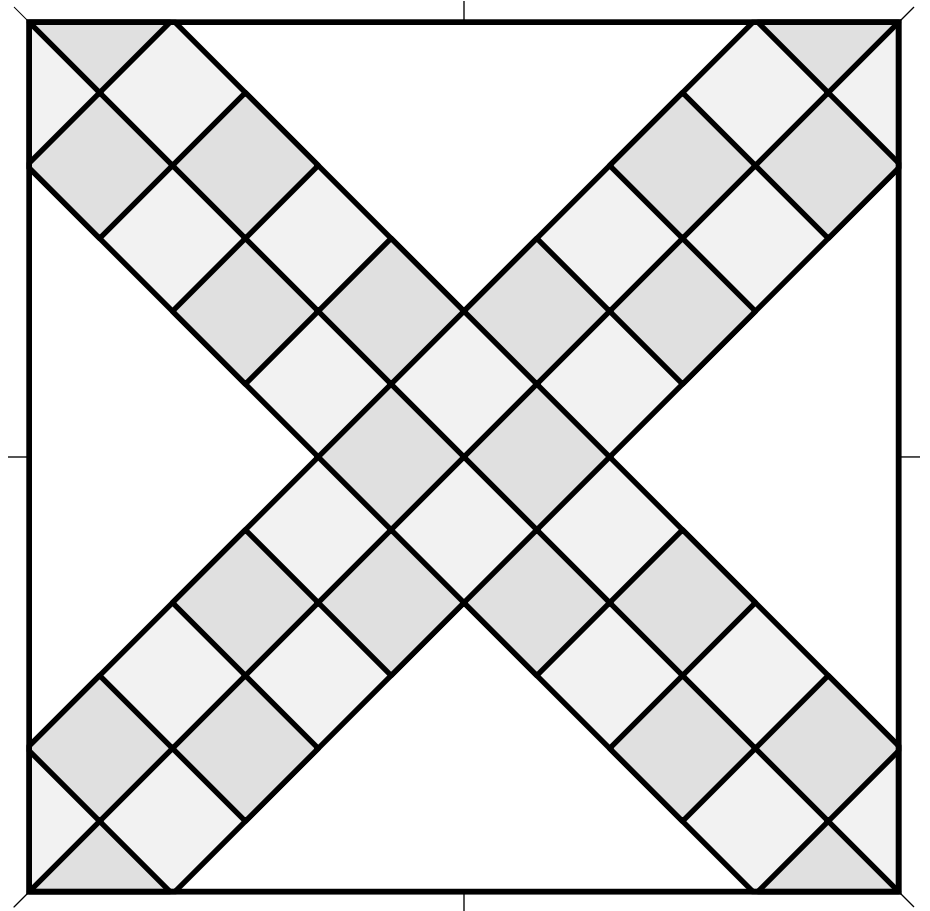
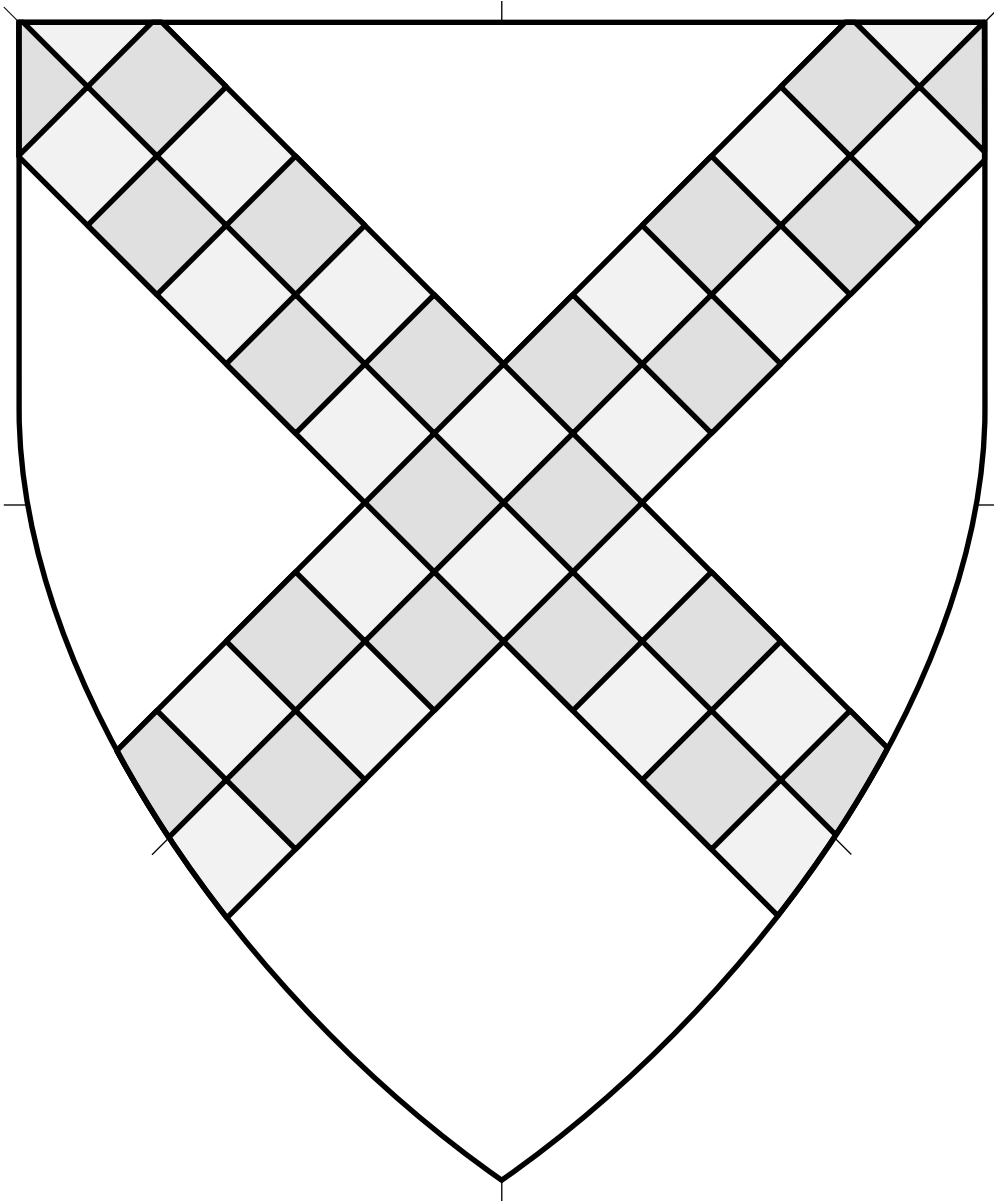

Central ordinary.

Saltire Counter-compony 4.567

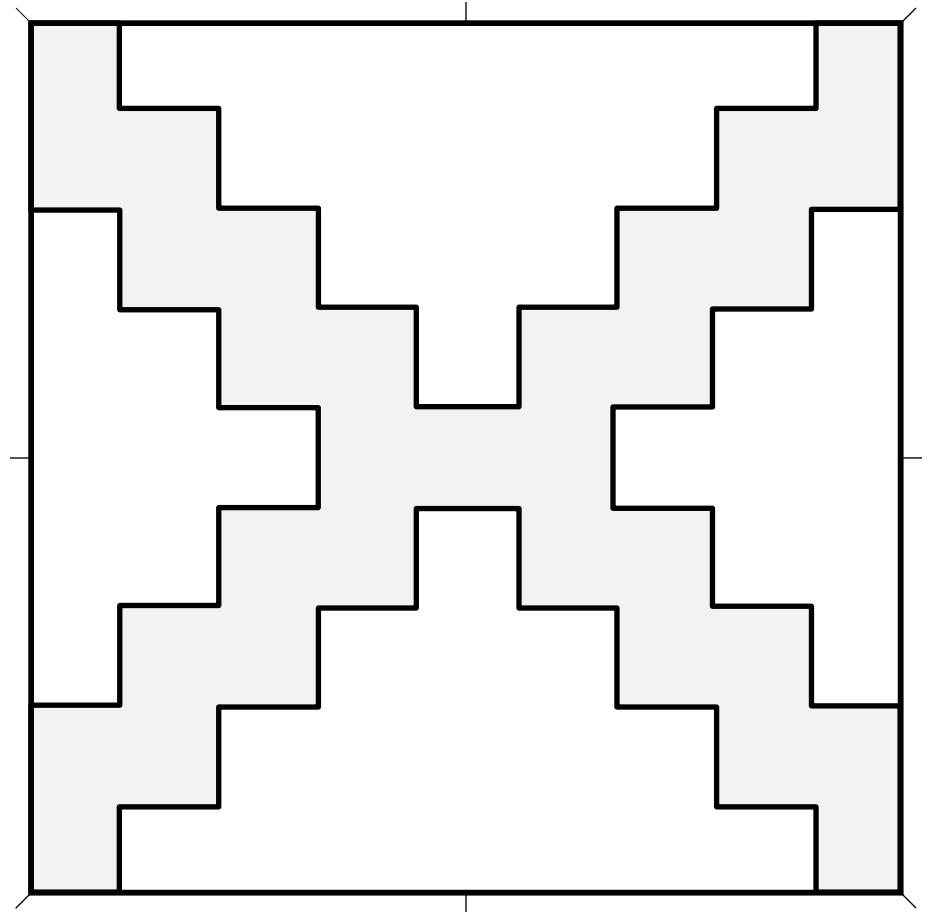
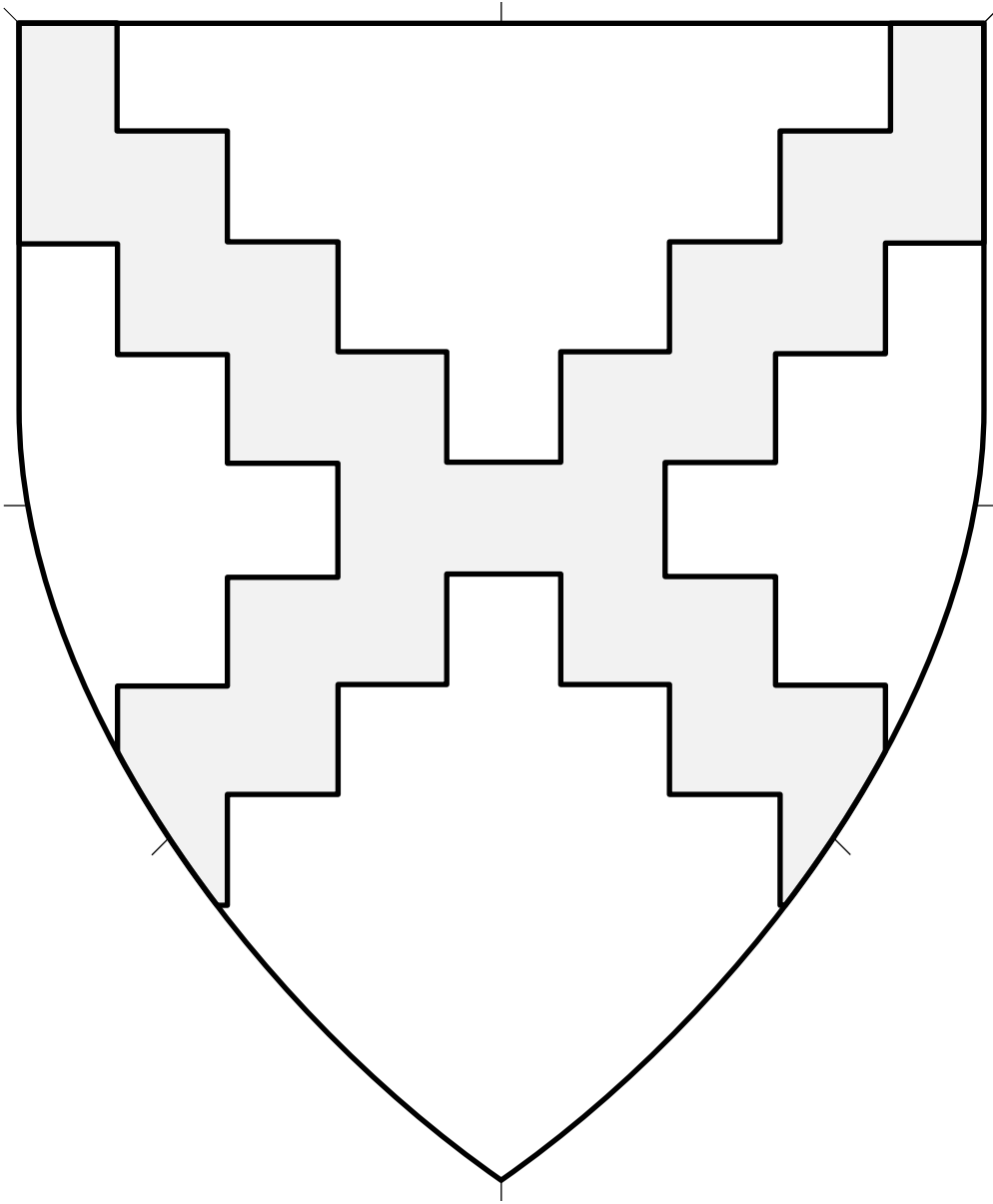

Central ordinary.

Source: Viking Answer Lady SVG Images For Heraldry.
Artist: Gunnvôr silfrahárr. Adapted by Mathghamhain Ua Ruadháin.

Saltire Dancetty 4.568

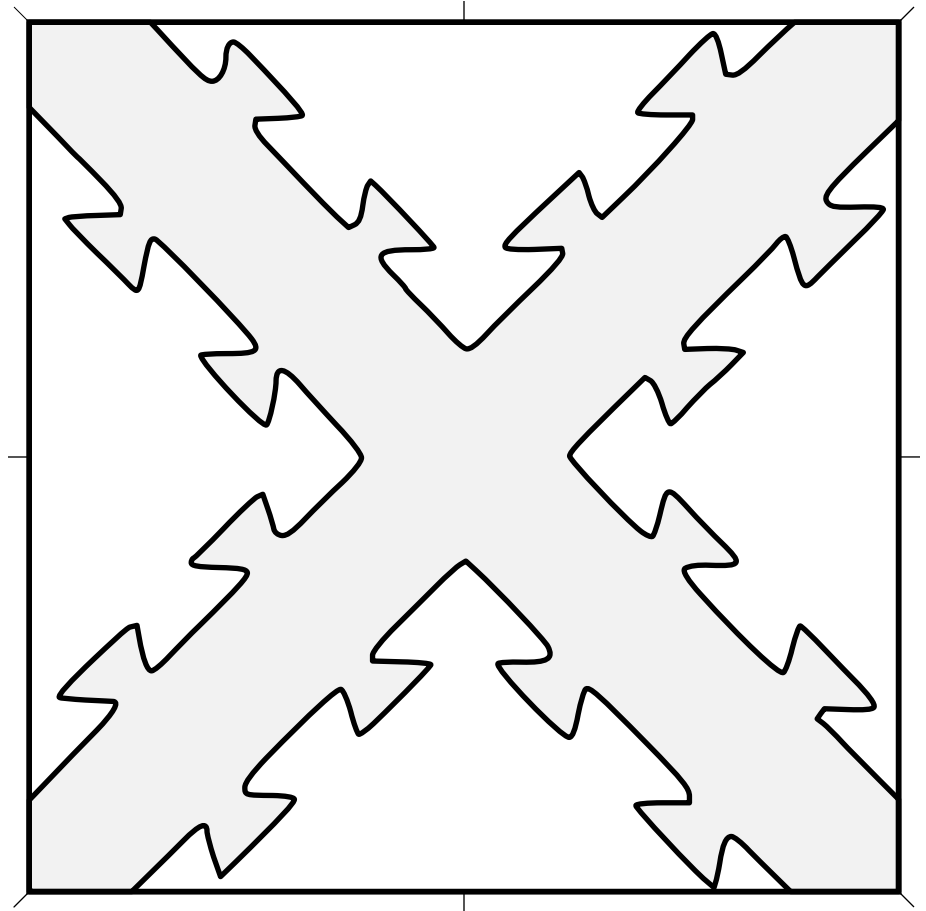
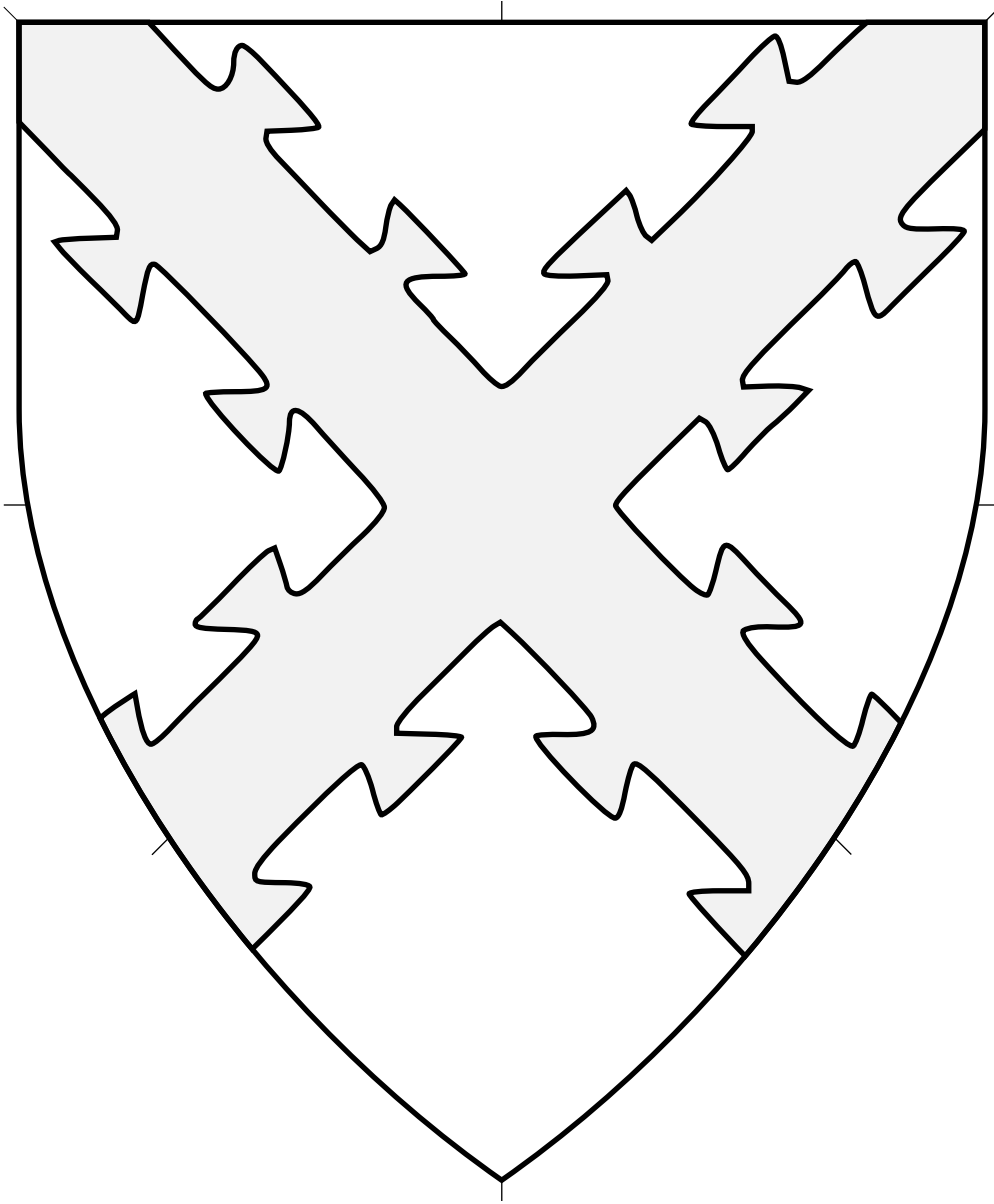

Central ordinary.

Source: A Complete Guide to Heraldry. Artist: Graham Johnston.

Saltire Dovetailed 4.569

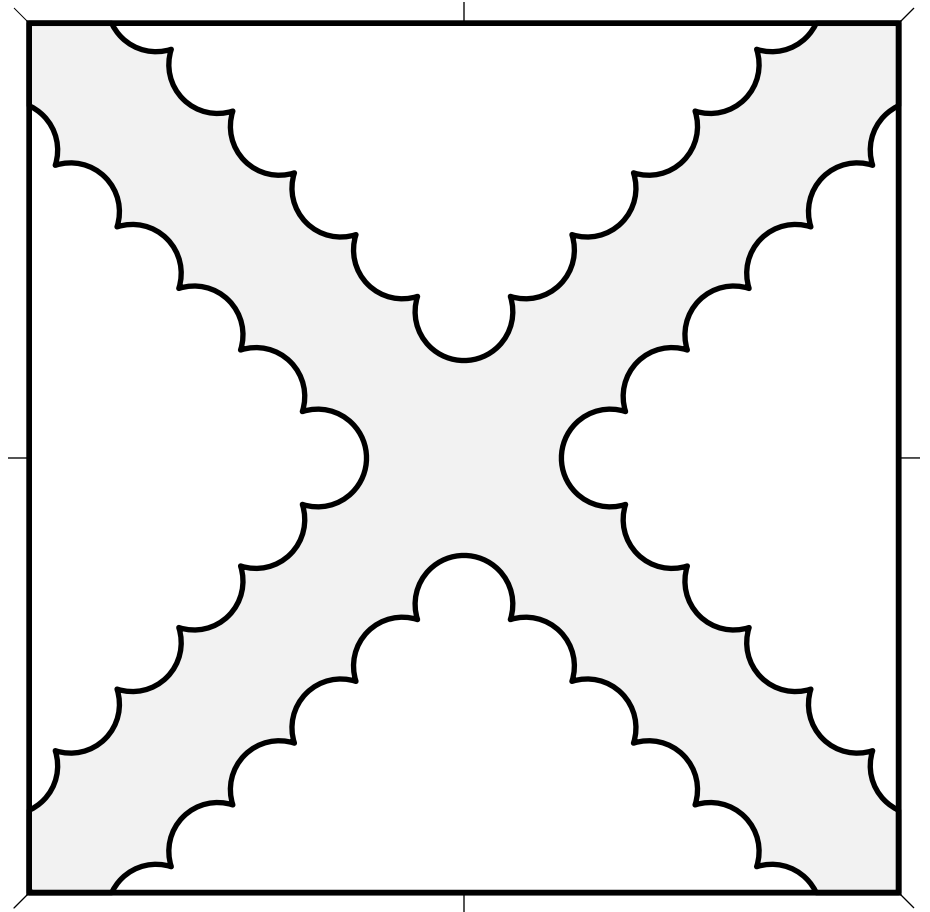
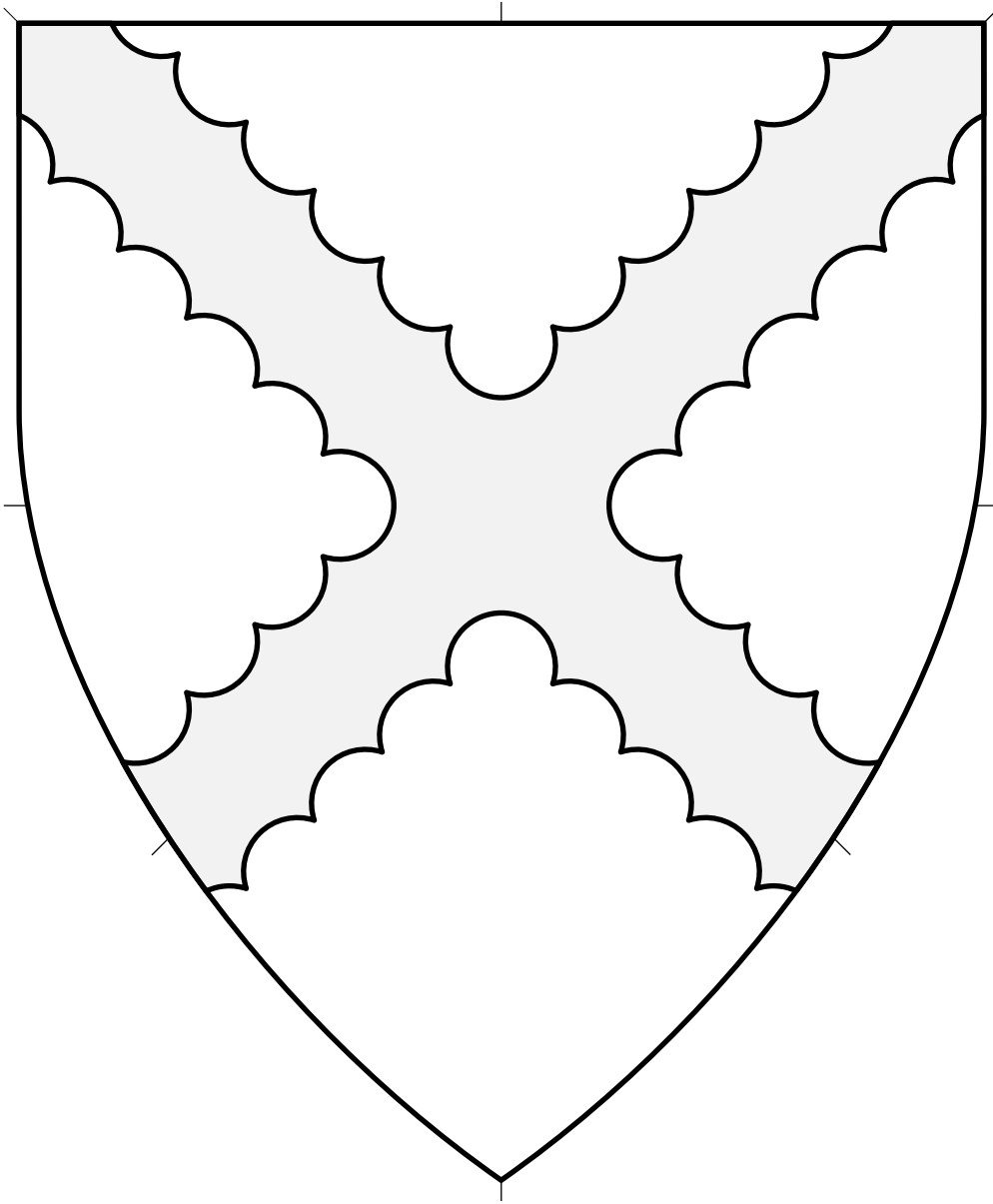

Central ordinary.

Source: Walters Ms. W.847. Artist unknown.
(Arms of Geffray Batotort, folio 10r.)

Saltire Engrailed (1) 4.570

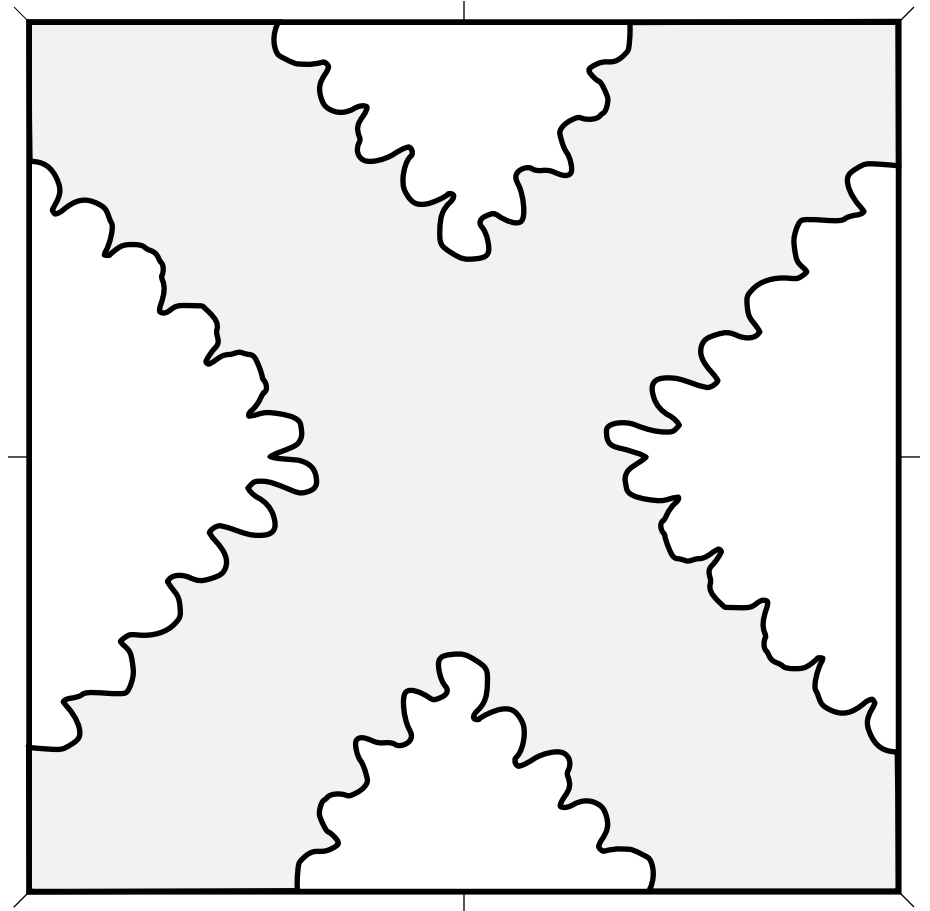
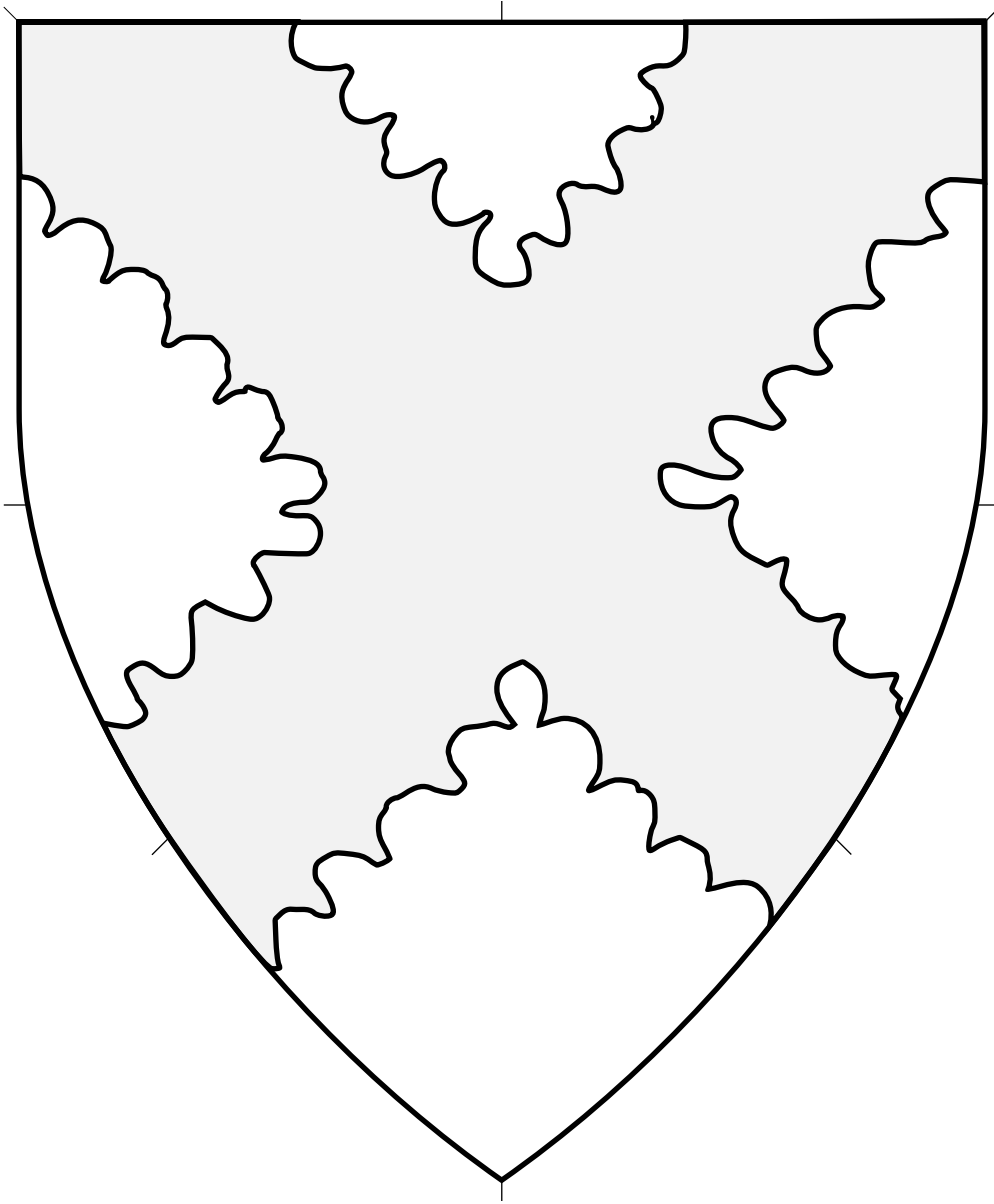

Central ordinary.

Source: Grand Armorial Colorié. Artist unknown. (Folio 265r.)

Saltire Engrailed (2) 4.571

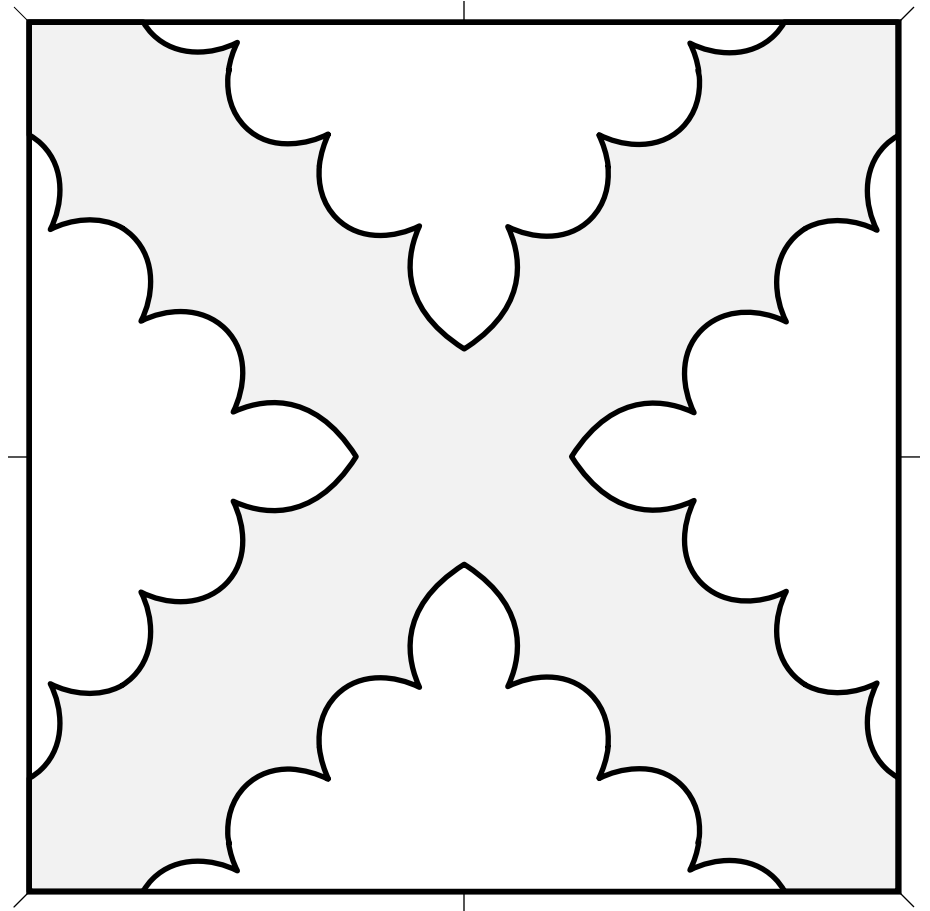
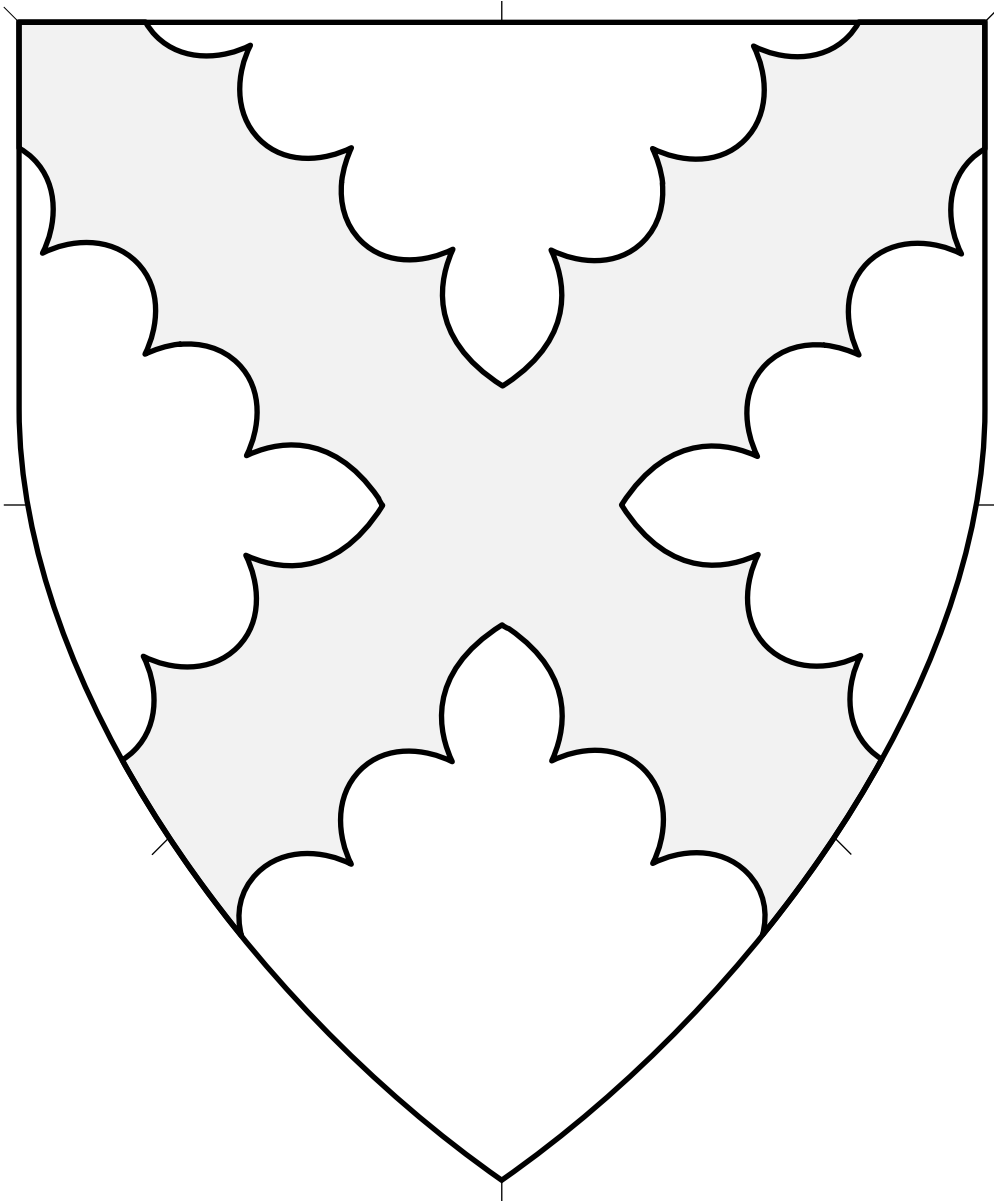

Central ordinary.

Source: WappenWiki. Artist: Joakim Spuller.
Adapted by Mathghamhain Ua Ruadháin.

Saltire Engrailed (3) 4.572

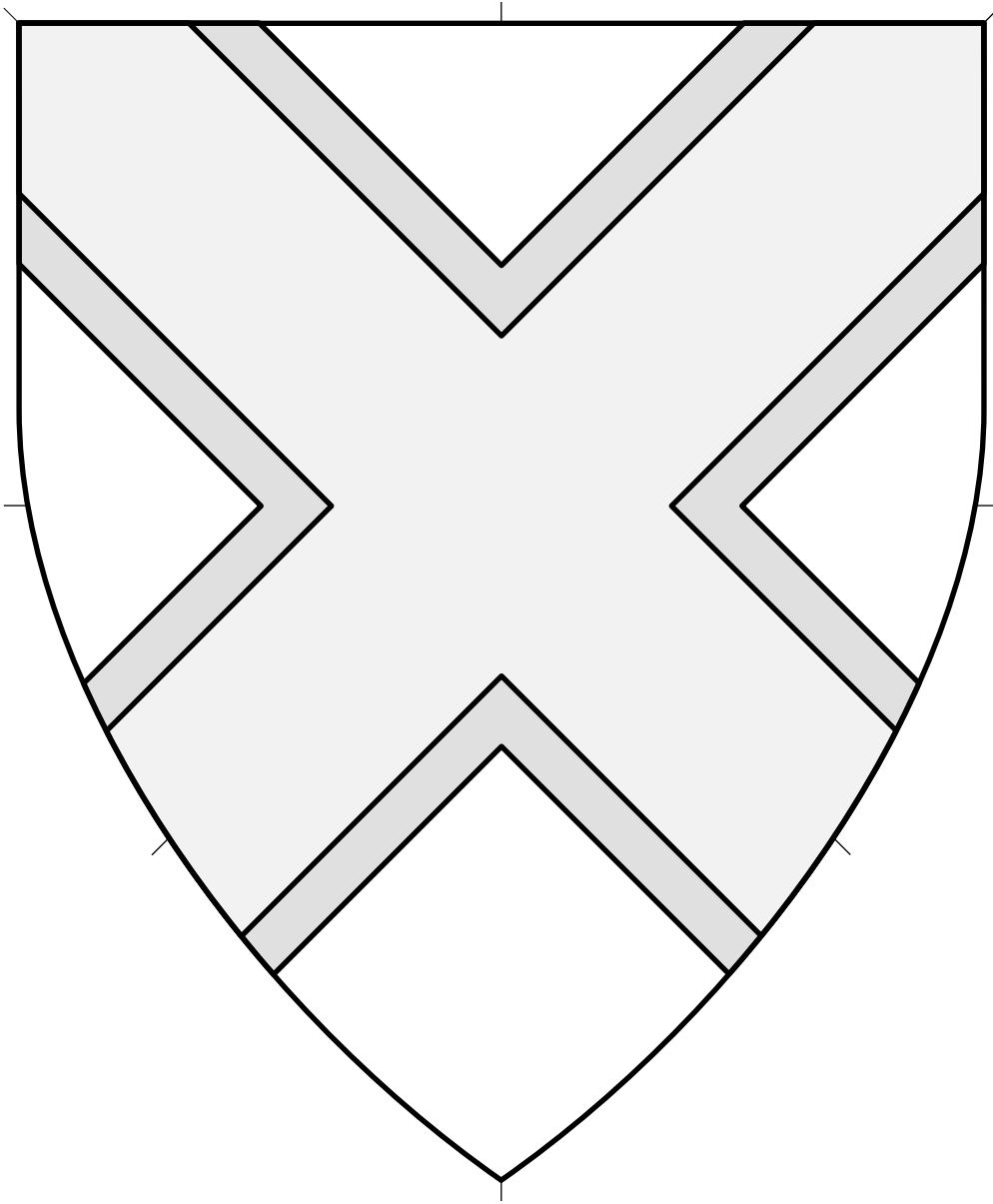

Central ordinary.

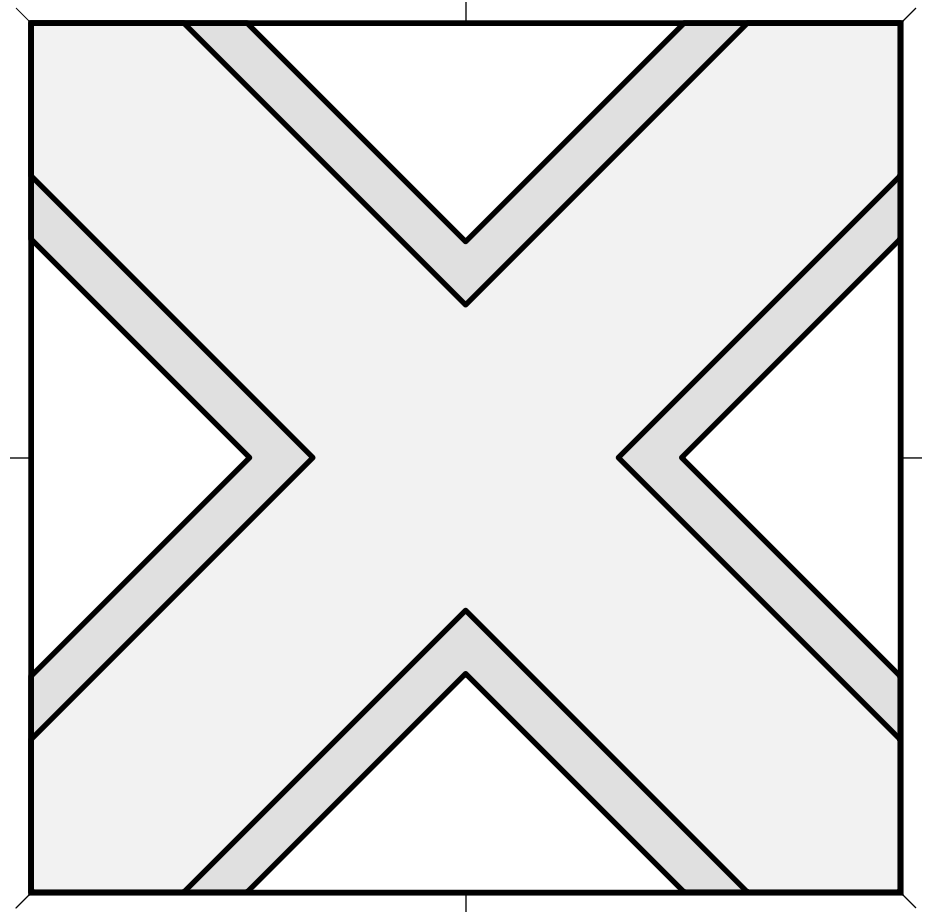

Saltire Fimbriated (1) 4.573

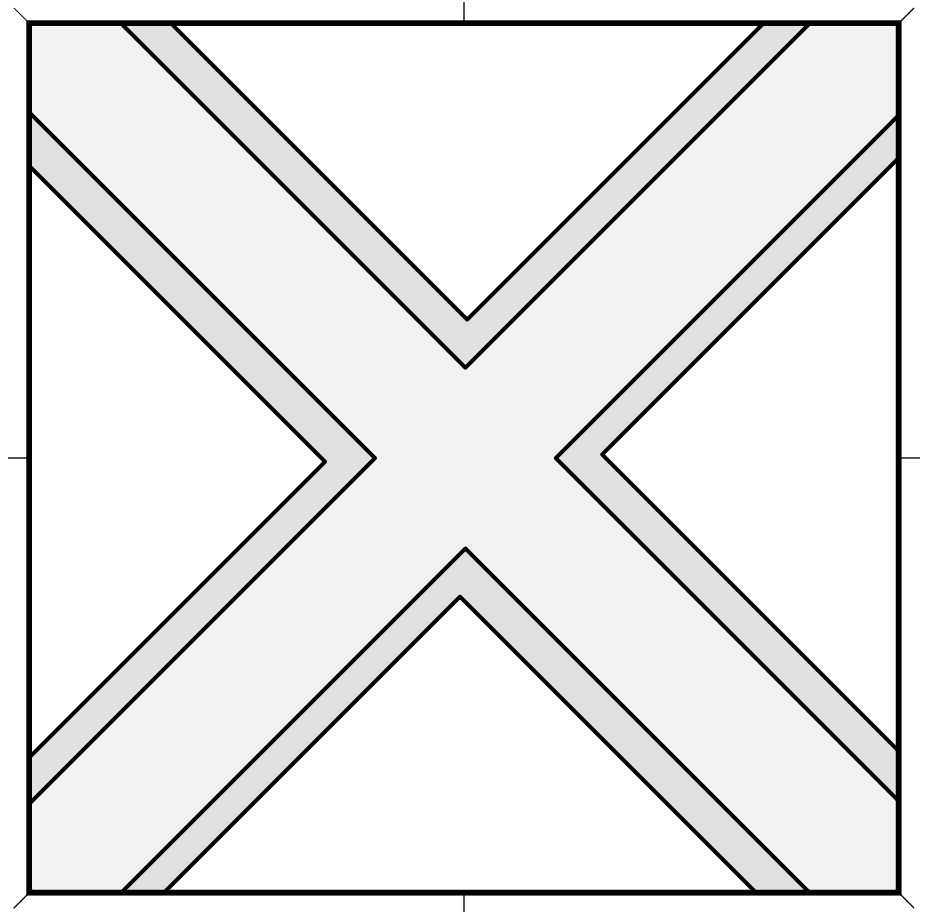
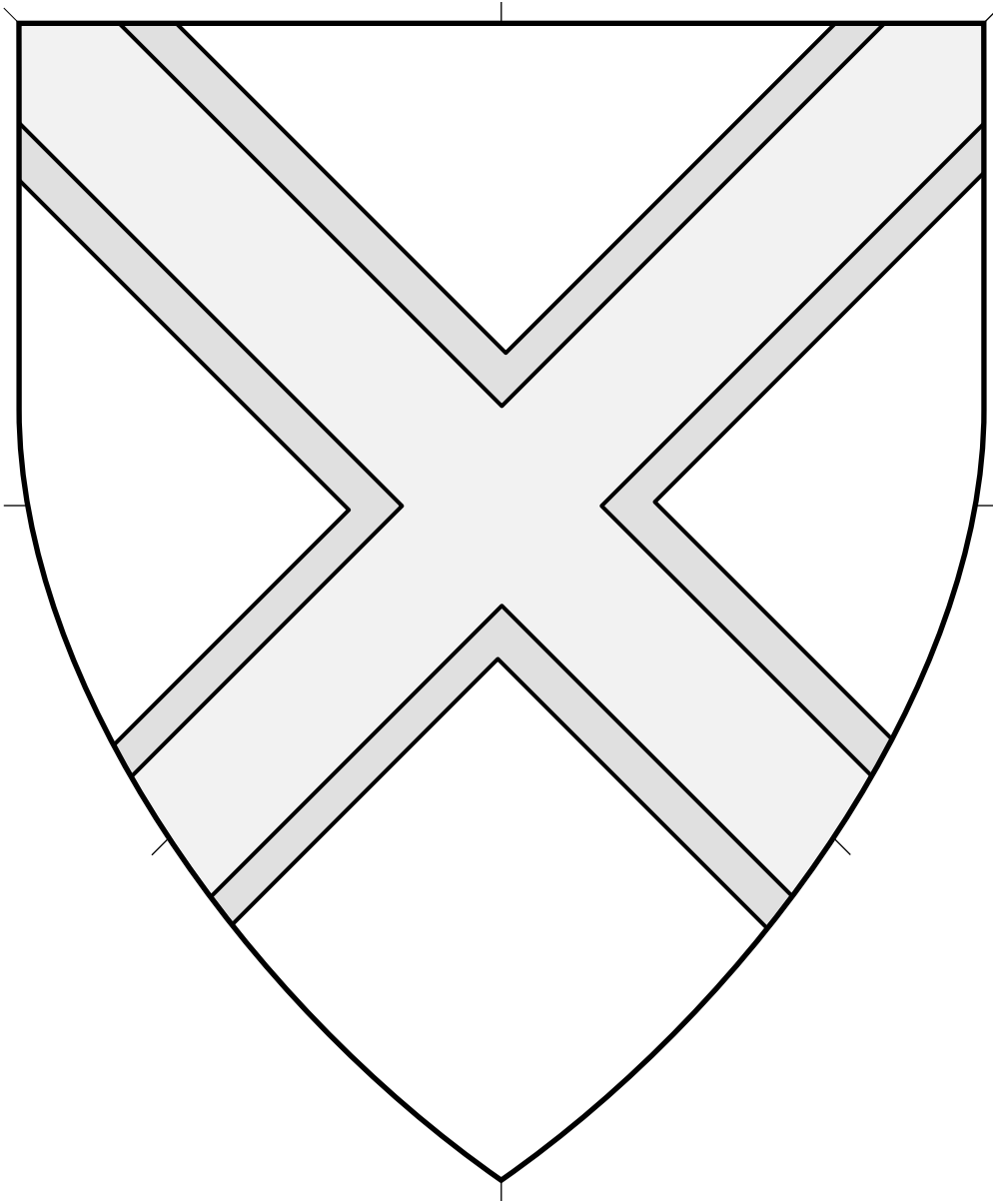

Central ordinary.

Source: Armorial Bearings of the Trading Companies and Lord Mayors of London. Artist unknown.

Saltire Fimbriated (2) 4.574

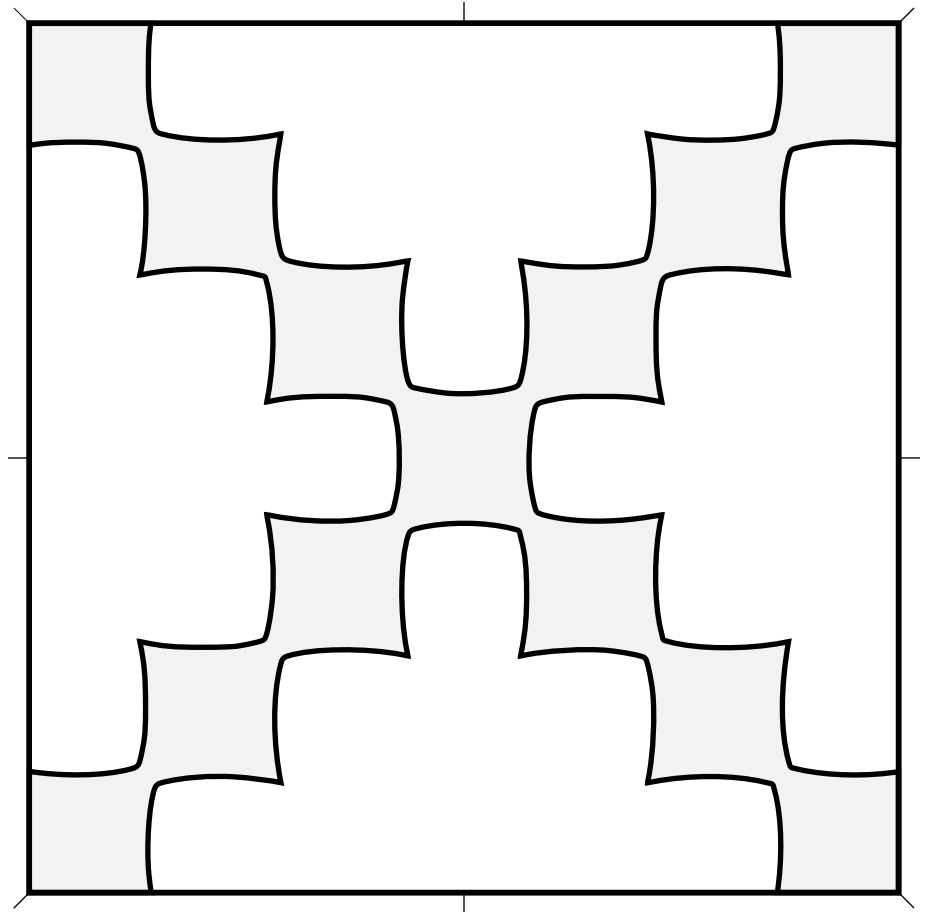
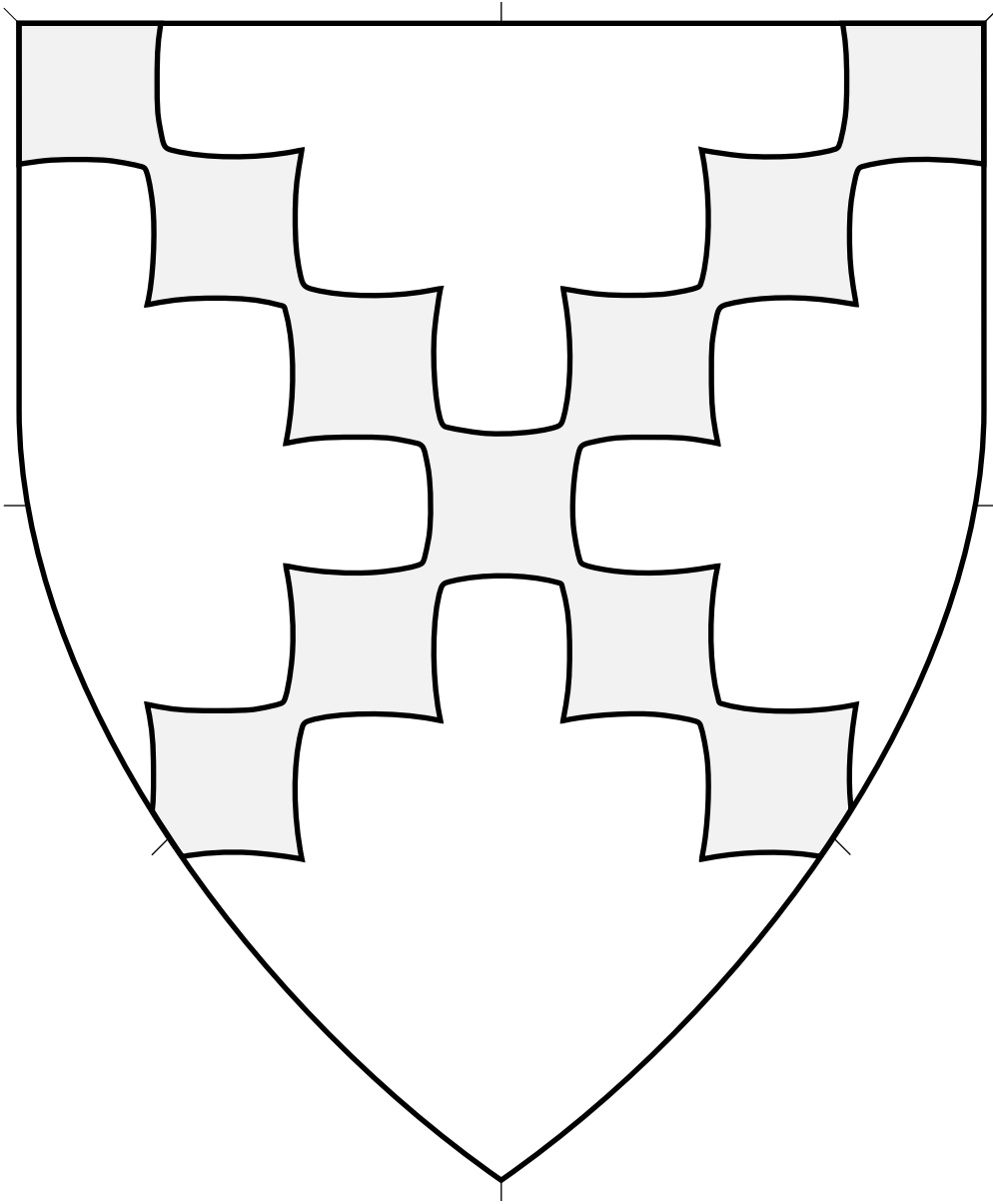

Central ordinary.

Source: Armorial de Gelre. Artist: Claes Heinenzoon. (Page 221.)

Saltire Fusilly 4.575

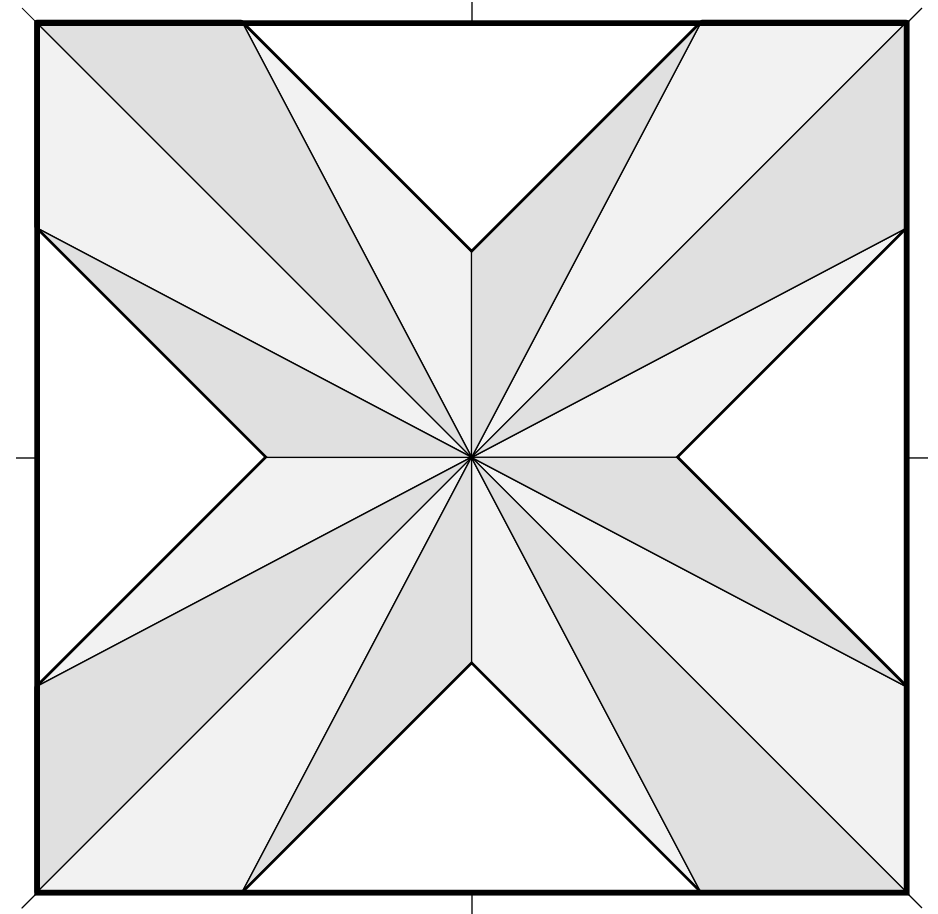
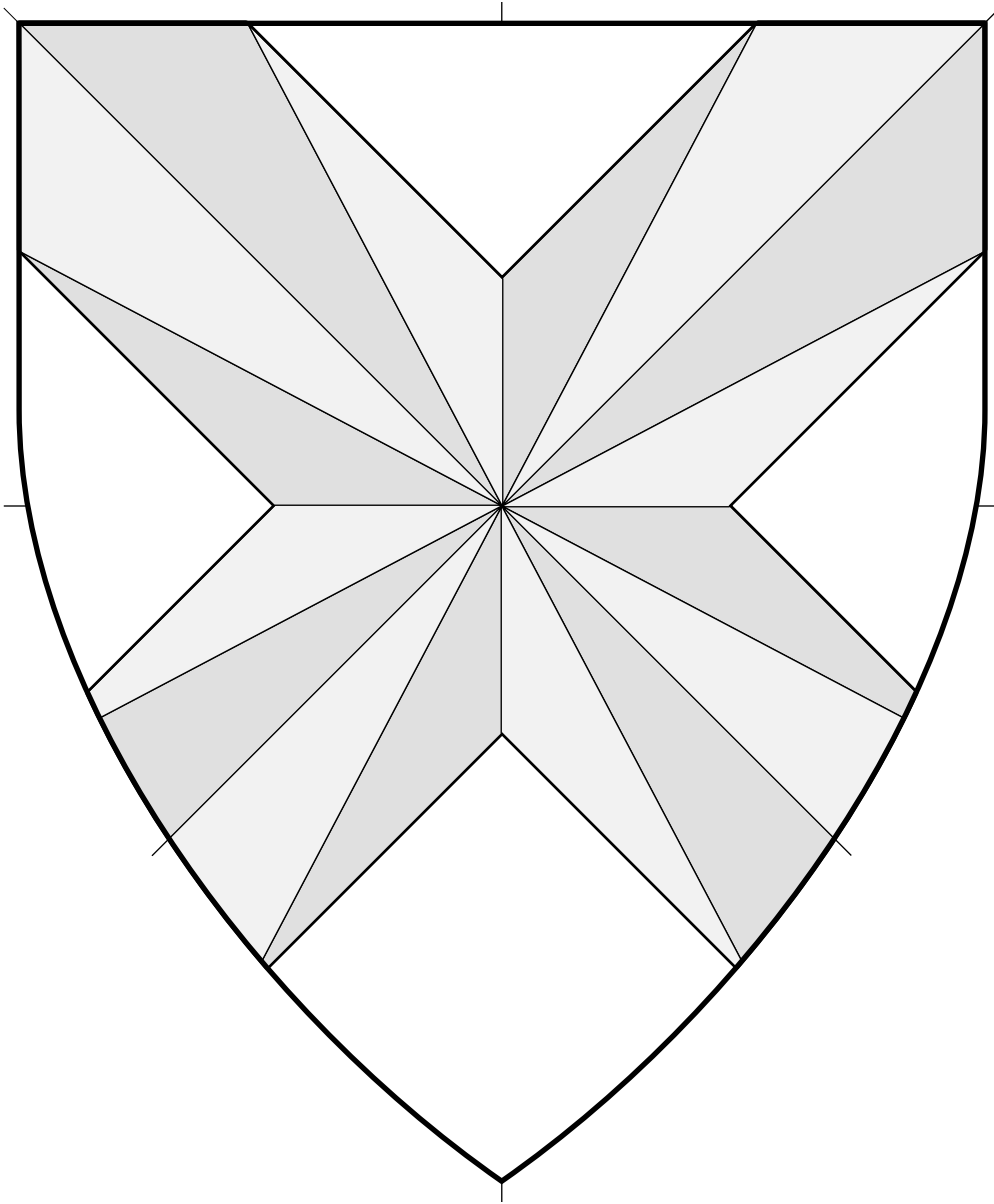

Central ordinary.

Source: Armorial Lorrain de la Première Moitié du XVIe Siècle.
(Page 146.) Artist unknown.

Saltire Gyronny 4.576

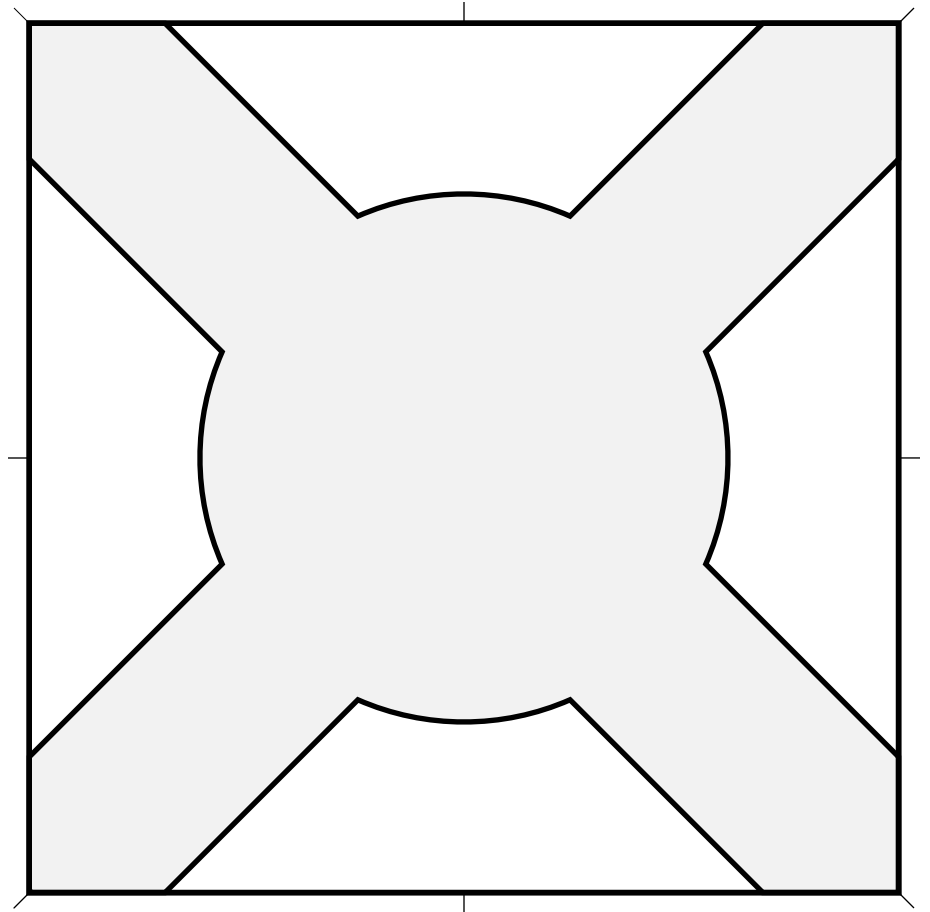
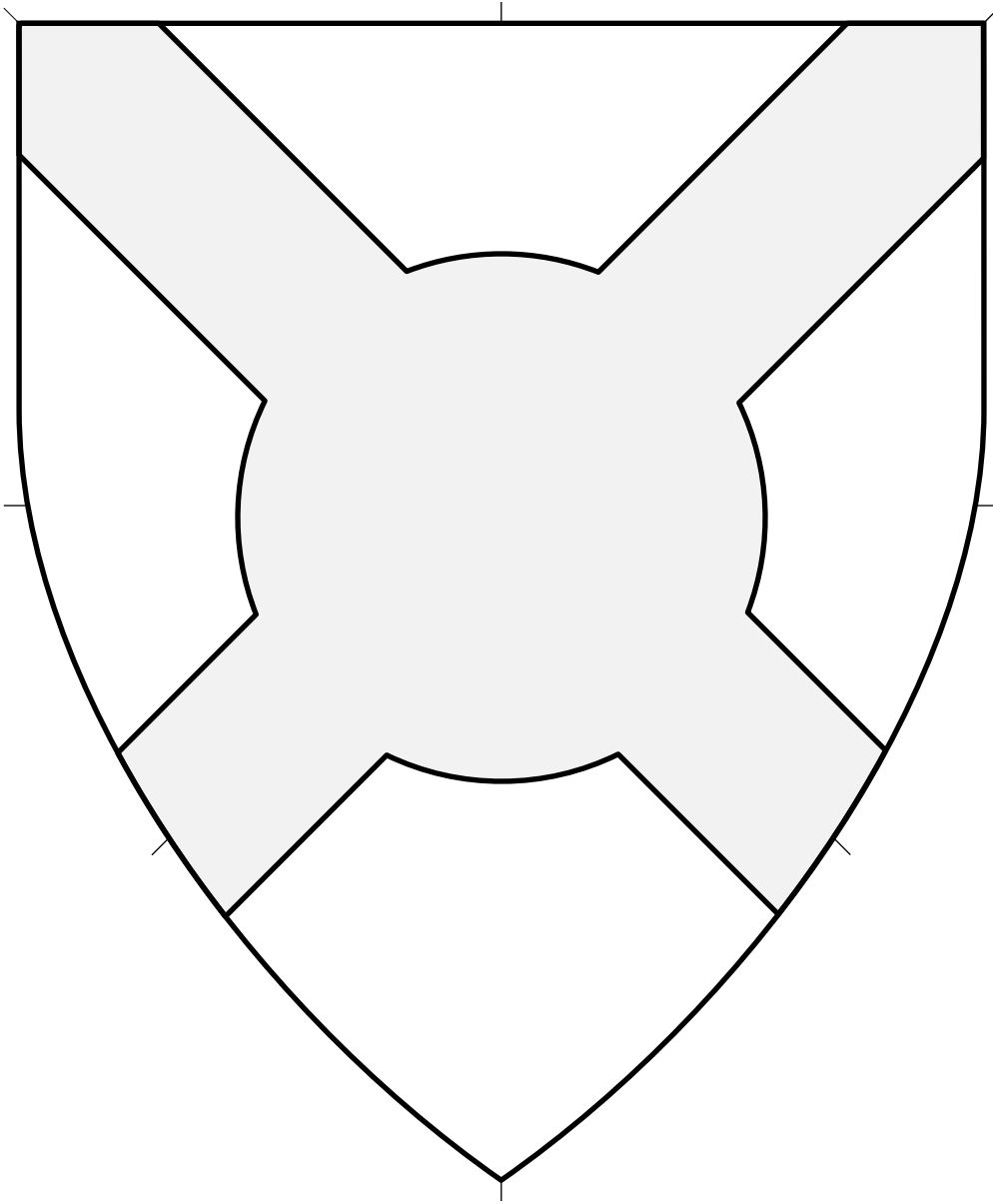

Central ordinary. A saltire with a circular protrusion in the center.
Considered a step from core practice (SFCP).

Saltire Nowy 4.577

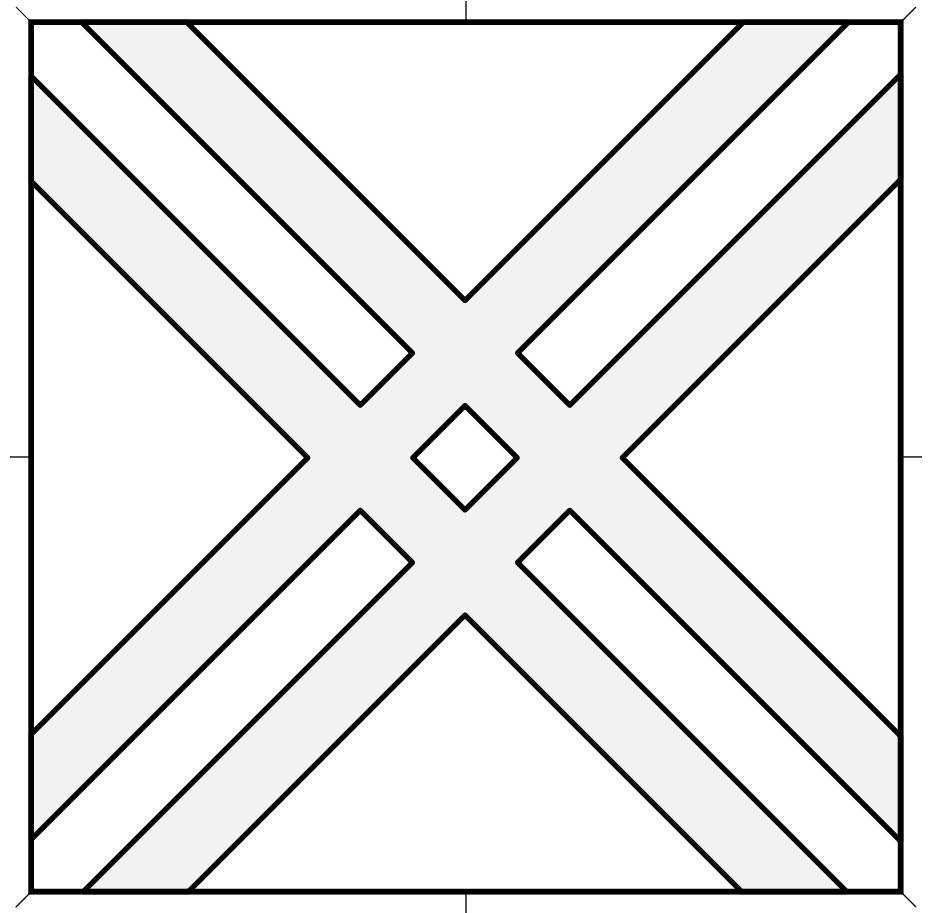
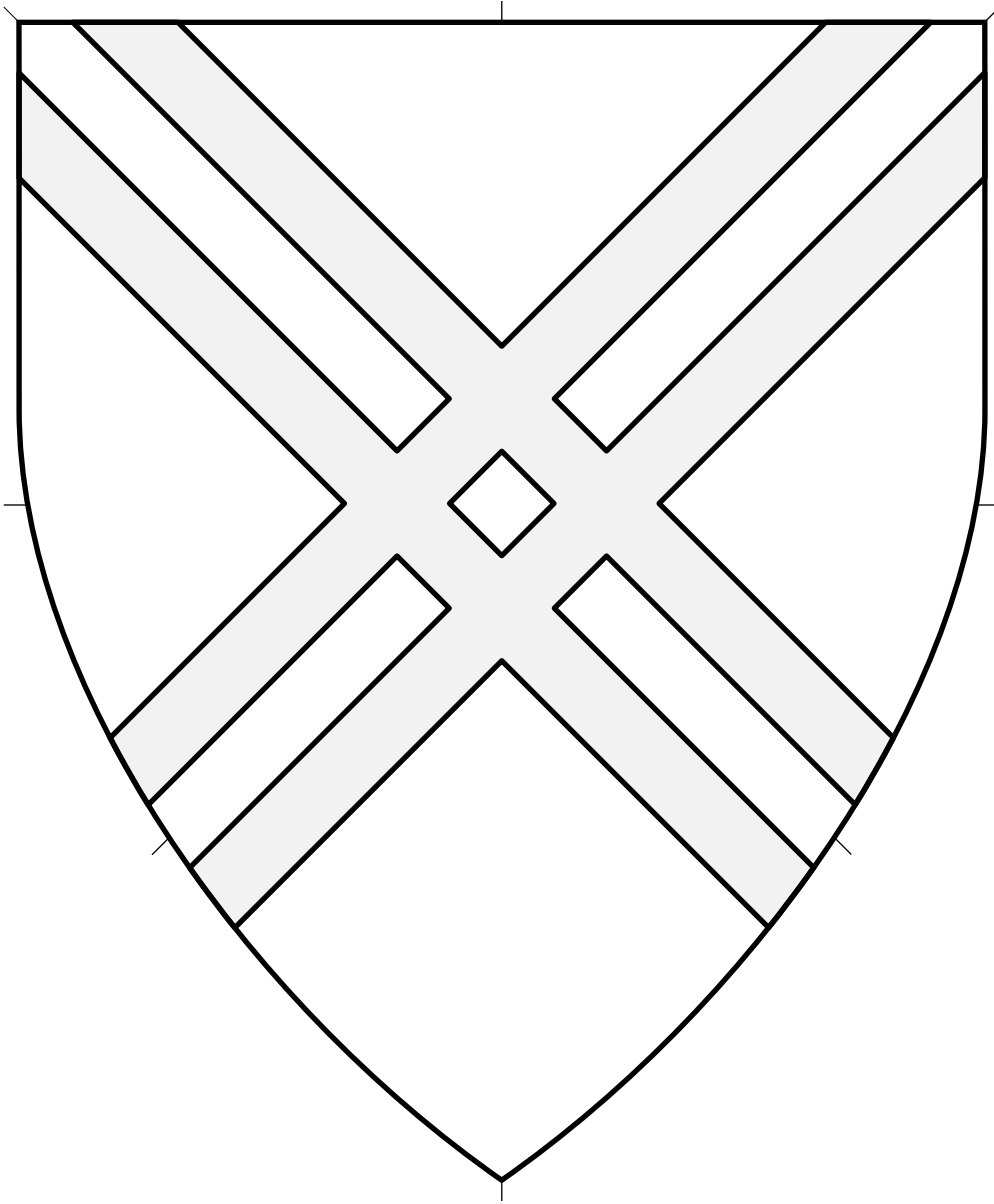

Central ordinary.

Source: A Complete Guide to Heraldry.

Artist: Graham Johnston.

Adapted by Mathghamhain Ua Ruadháin.

Saltire Parted 4.578

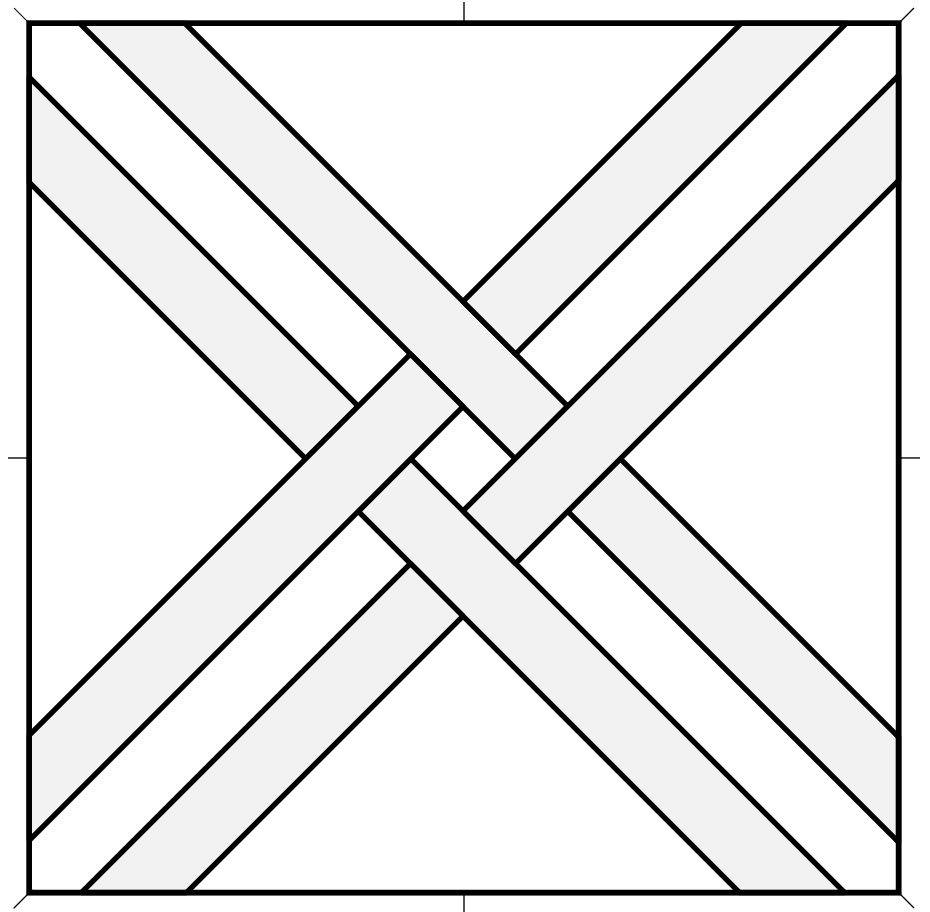
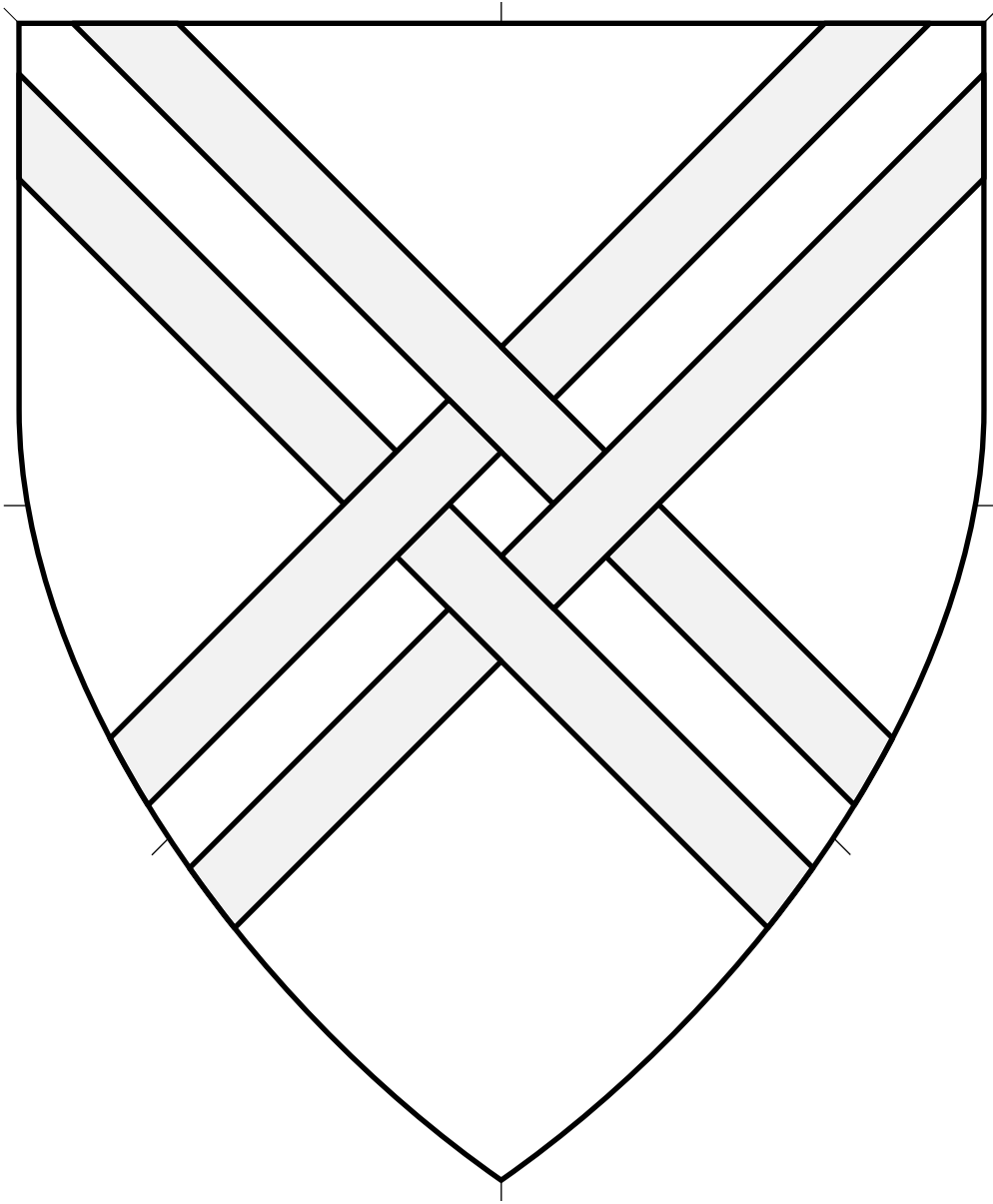

Central ordinary.

Source: A Complete Guide to Heraldry.
Artist: Graham Johnston.

Saltire Parted and Fretted 4.579

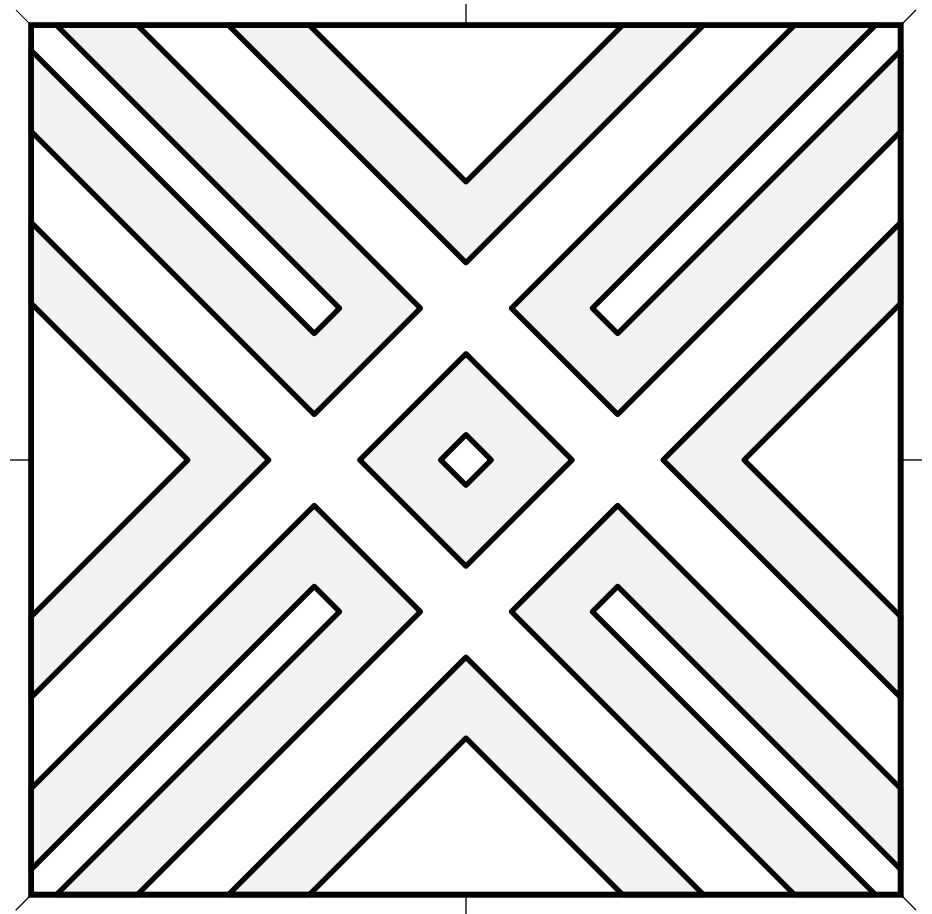
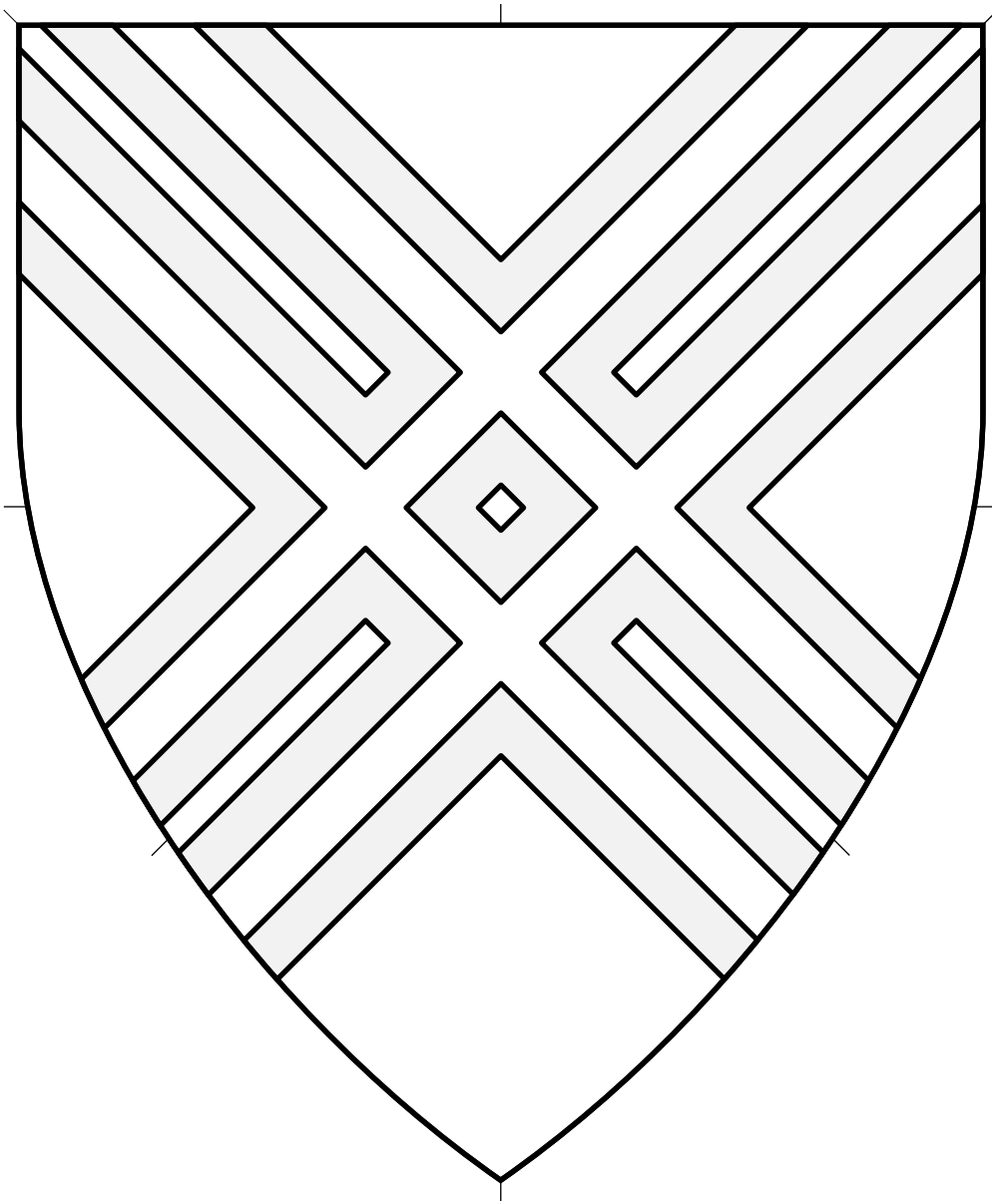

Central ordinary.

Source: Priorista di Giuliano de' Ricci.
Artist unknown. (Vol. I, folio 58r,
arms of Ruffoli.)

Saltire Parted and Voided 4.580

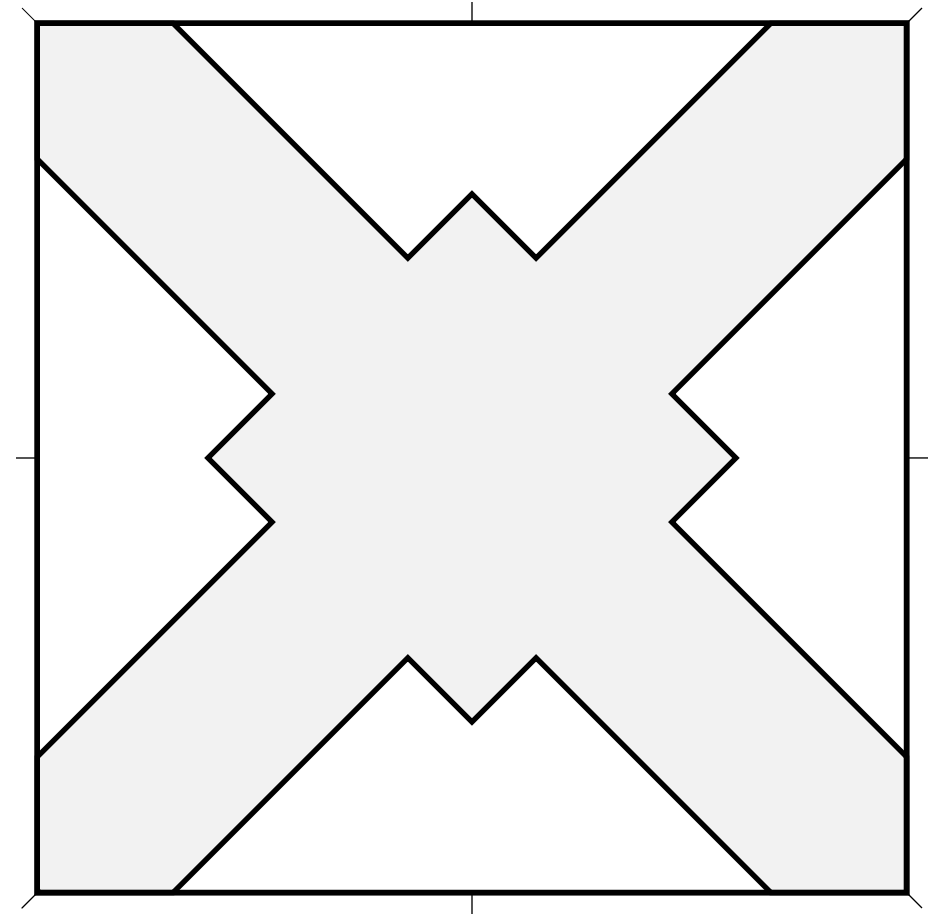
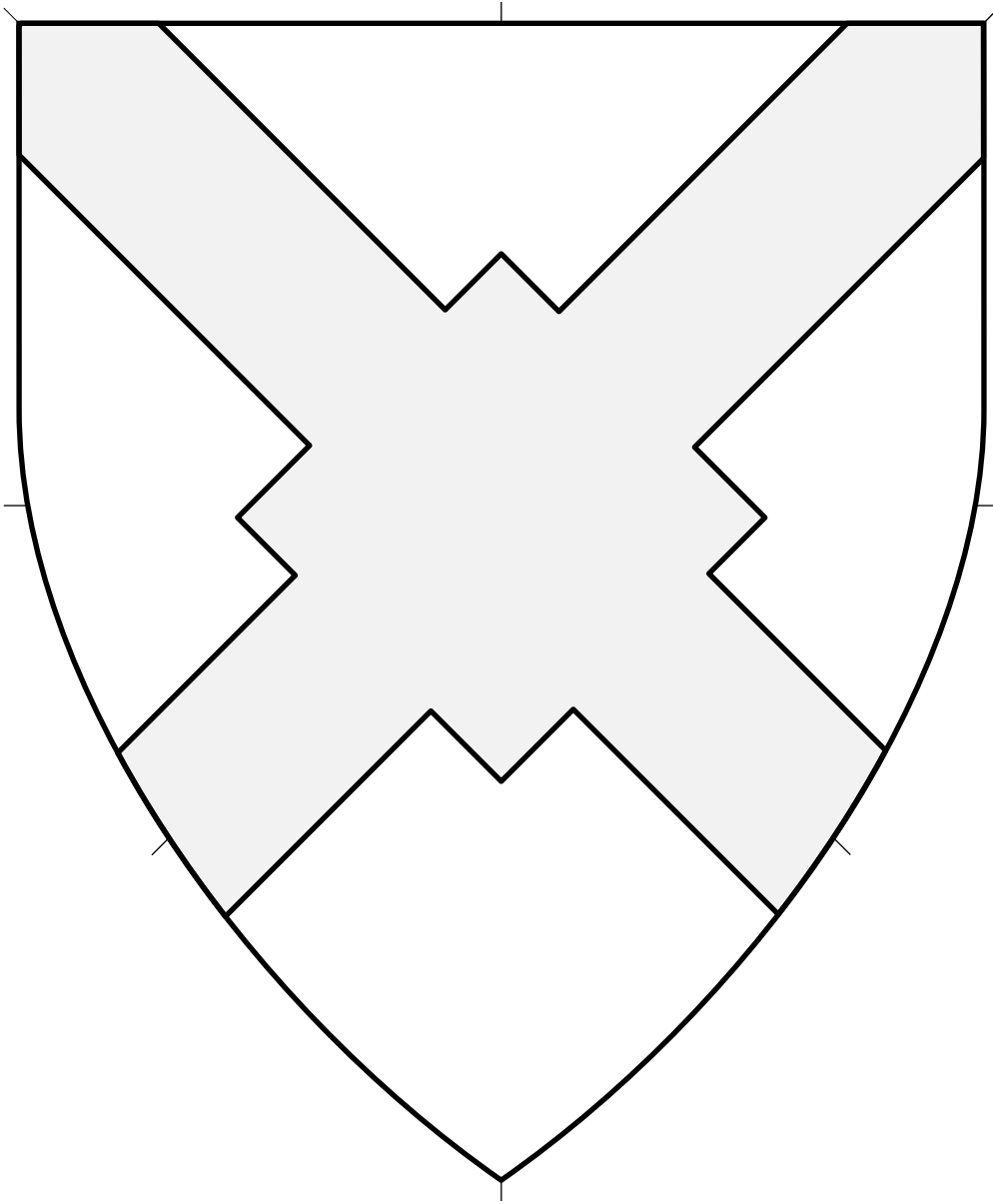

Central ordinary. A saltire with a square protrusion in the center.
Considered a step from core practice (SFCP).

Saltire Quadrated 4.581

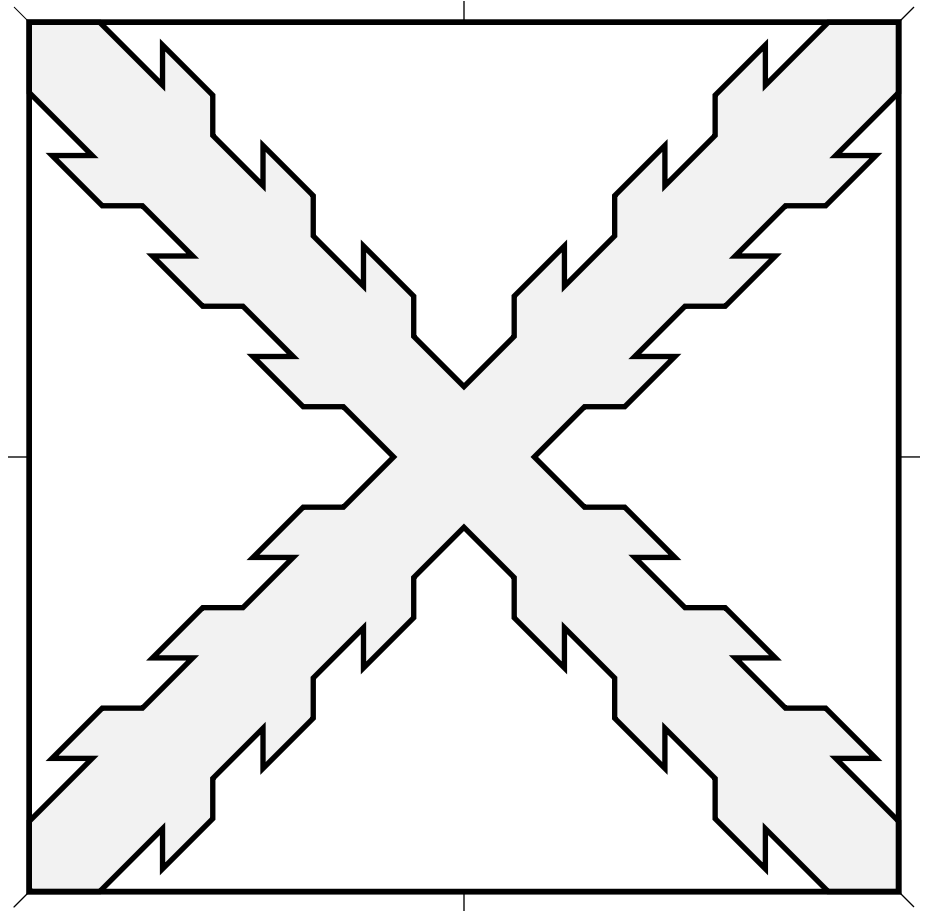
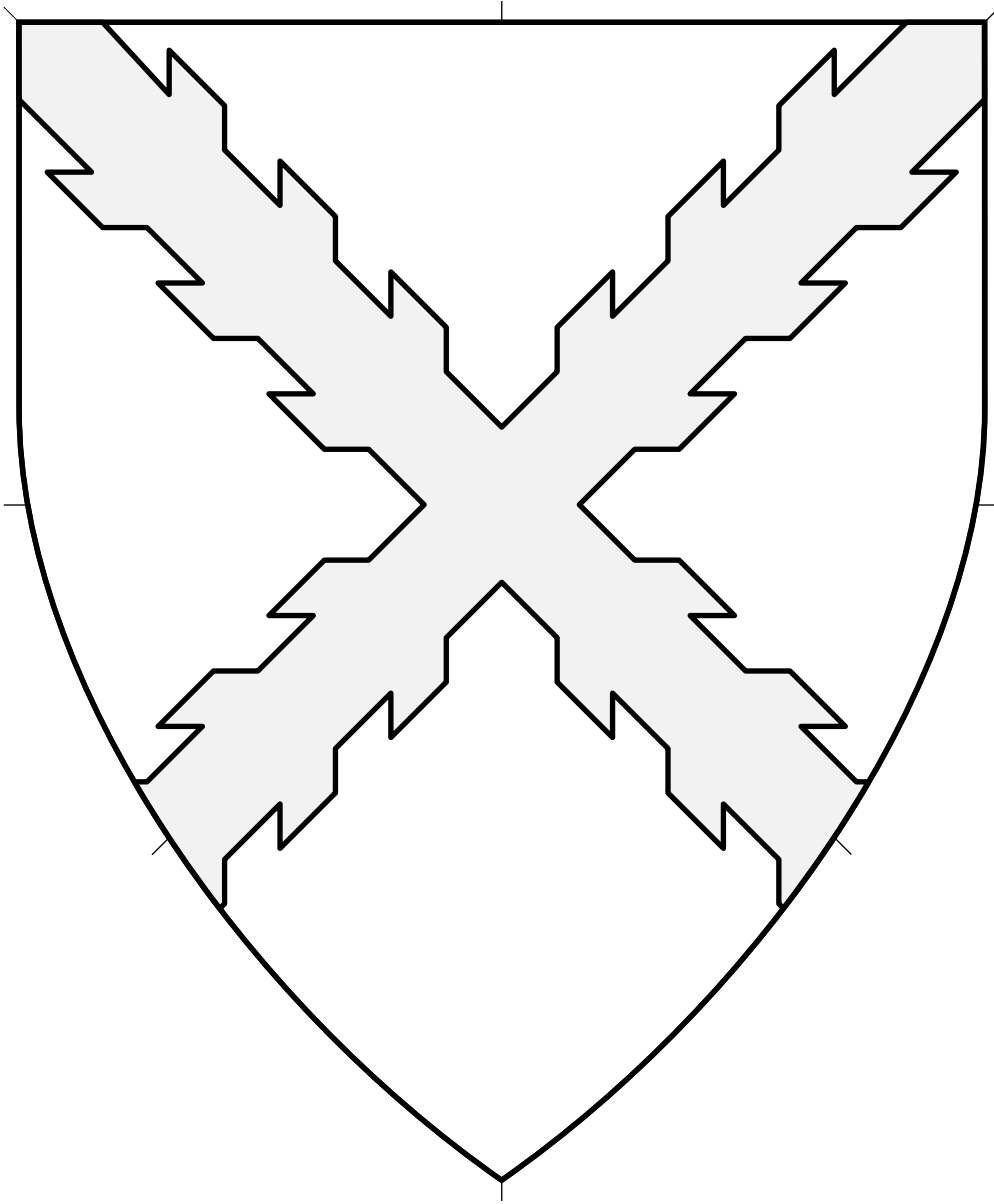

Central ordinary.
Also called the "Burgundy cross" and used by the modern Spanish Carlists.

Saltire Raguly (1) 4.582

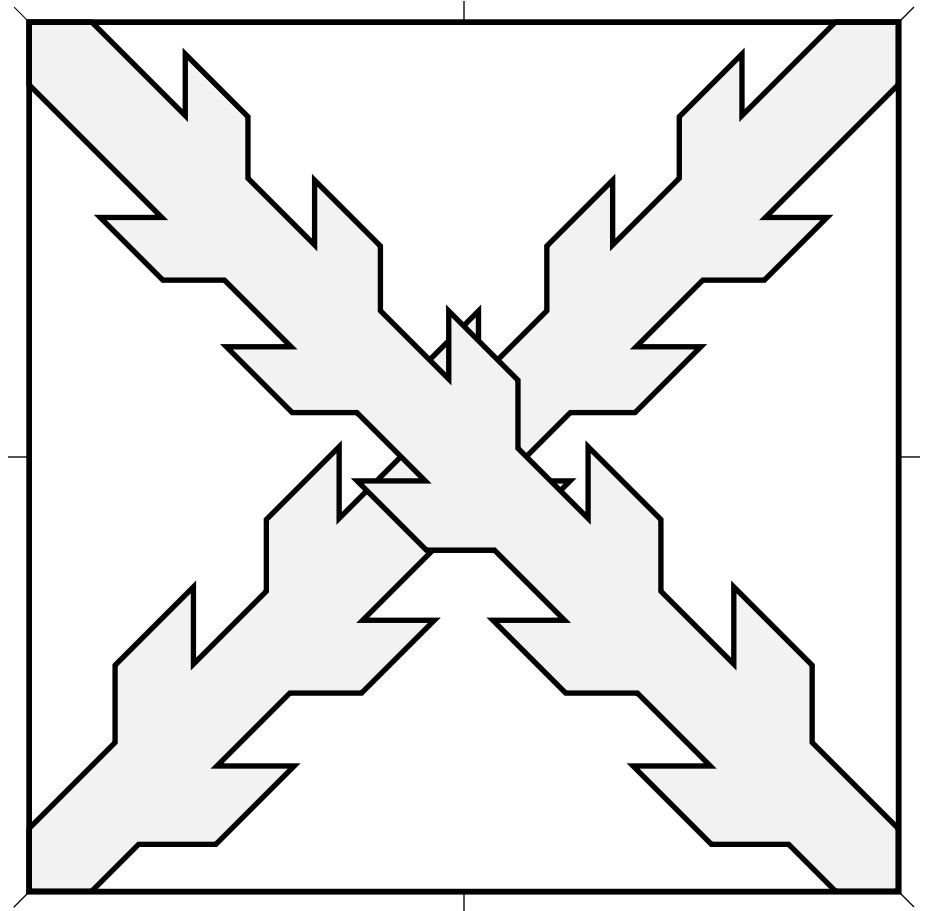
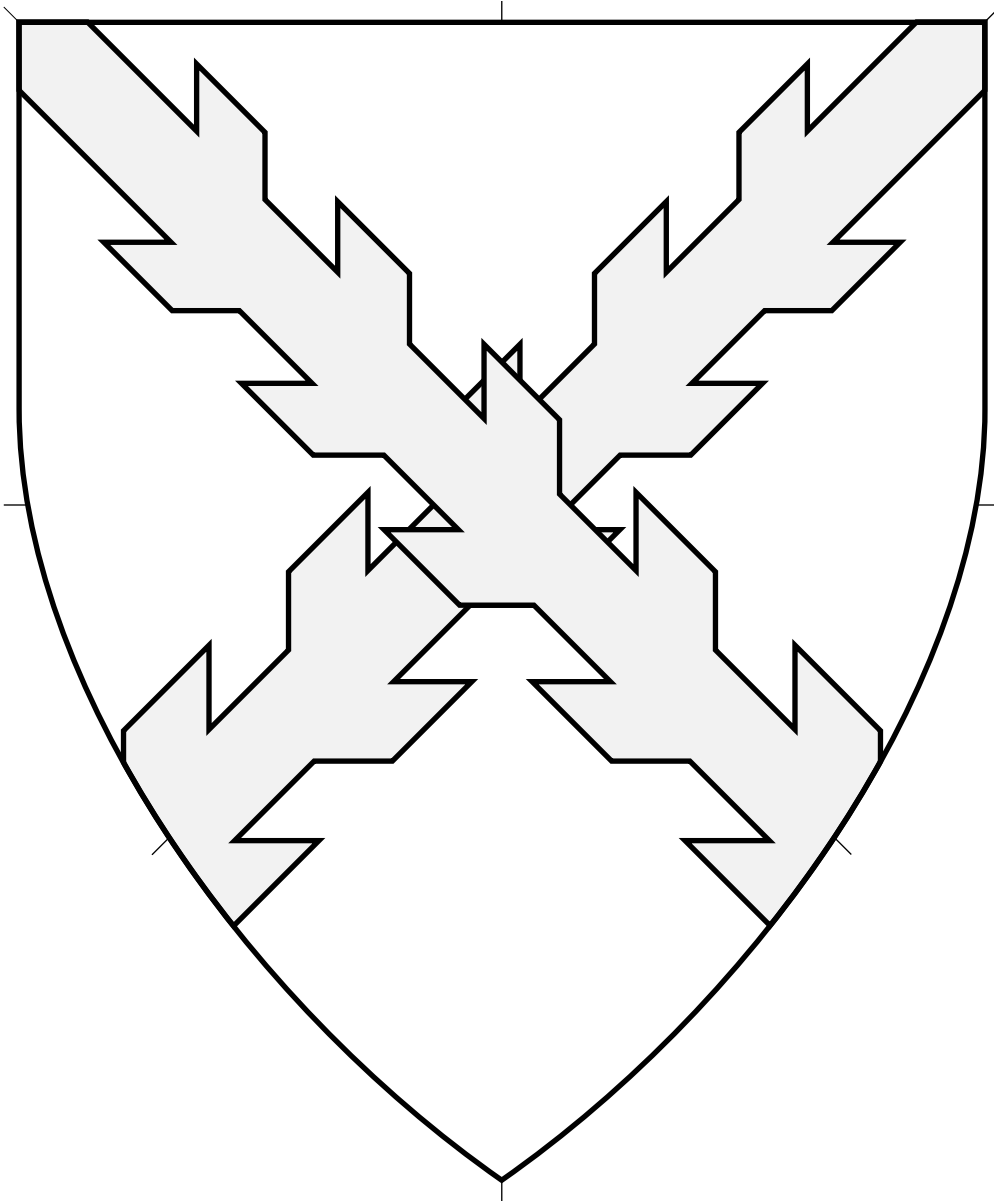

Central ordinary.

Also called the "Burgundy cross" and used by the modern Spanish Carlists.

Source: Ehrenspiegel des Hauses Österreich. Artist unknown. (Page 579.)

Saltire Raguly (2) 4.583

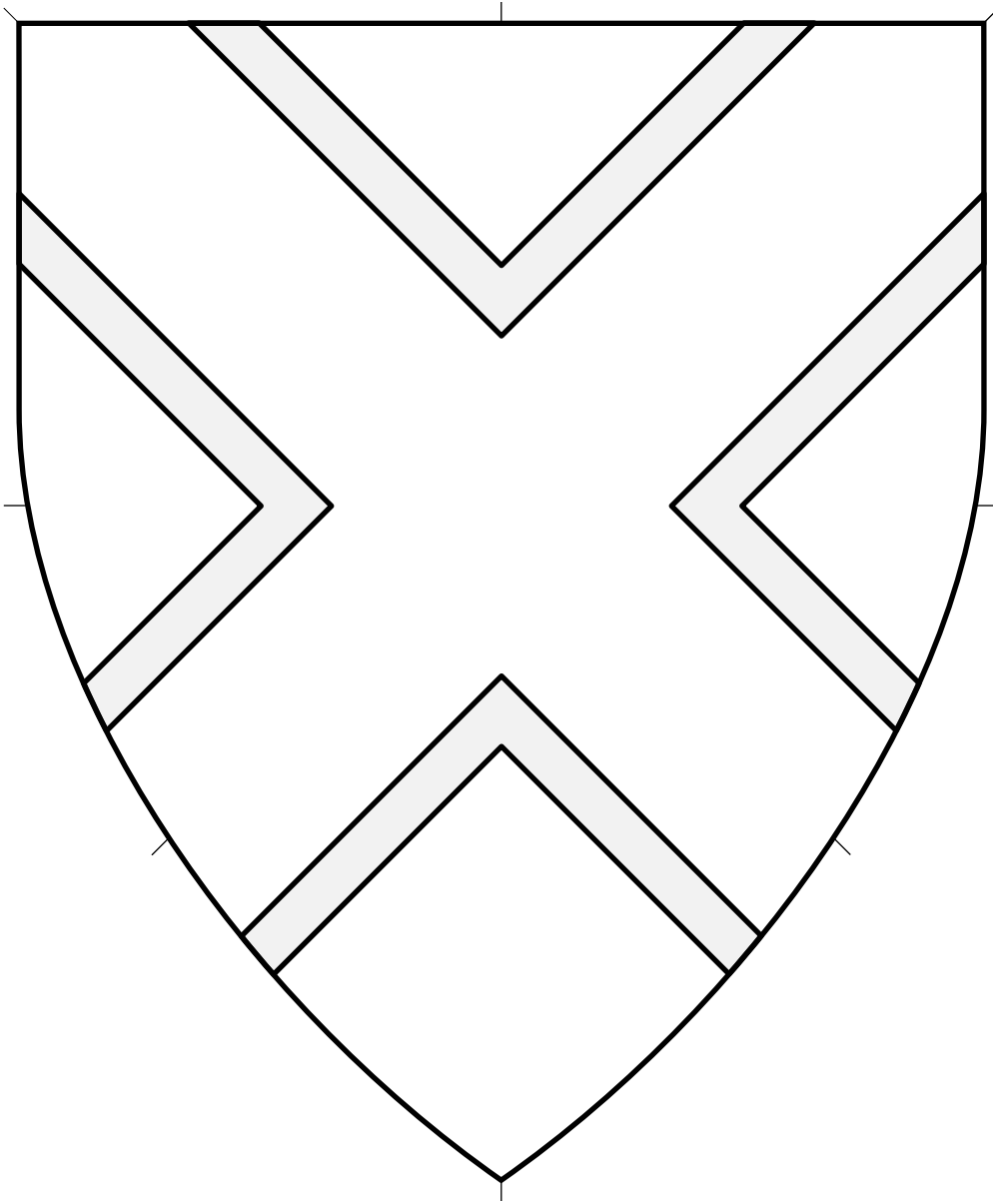

Central ordinary.

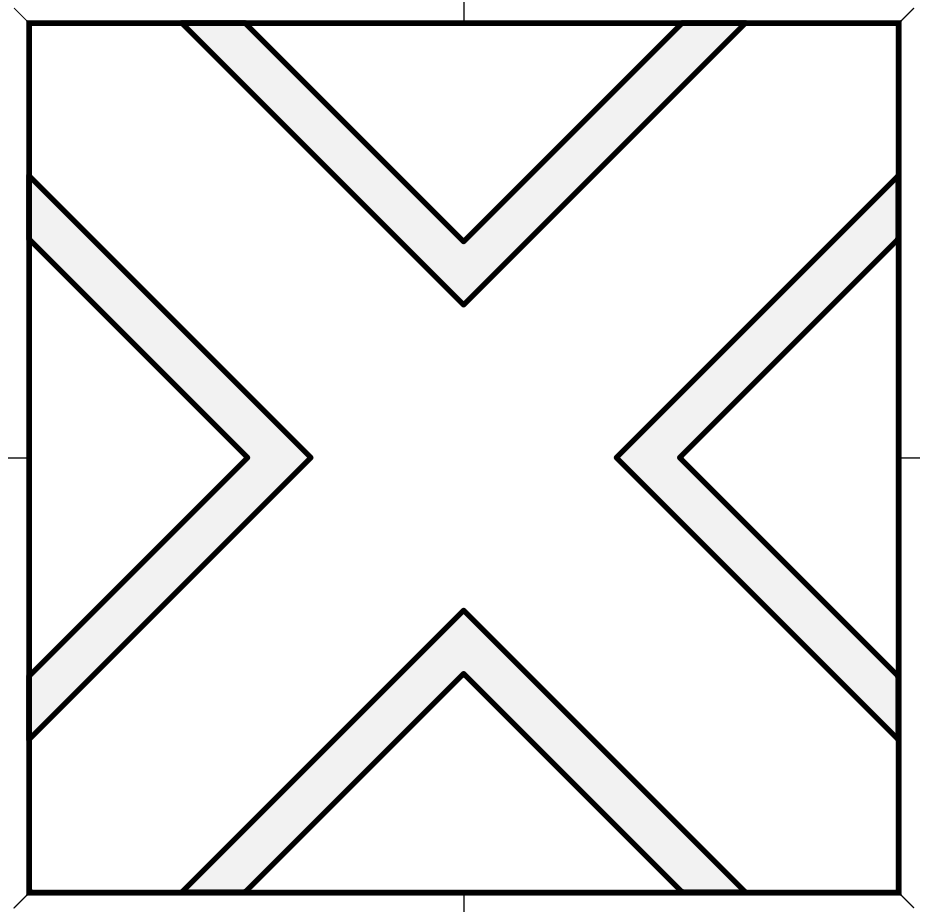

Saltire Voided 4.584

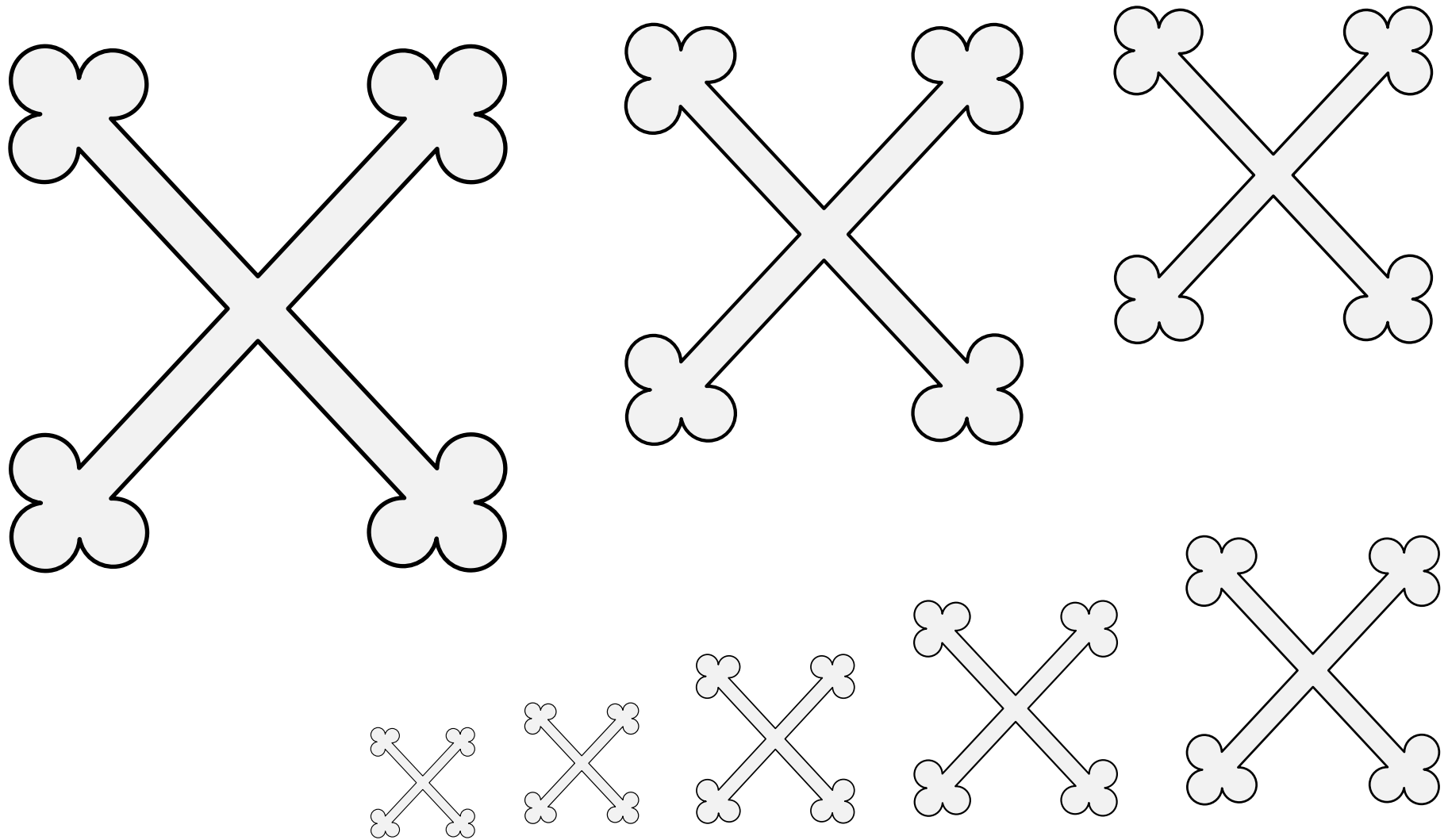

Couped ordinary.

Source: Wappenbuch der Arlberg-Bruderschaft.
Artist: Vigil Raber. (Arms of Bursckrafft, page 794.)

Saltire Bottonny (1) 4.585

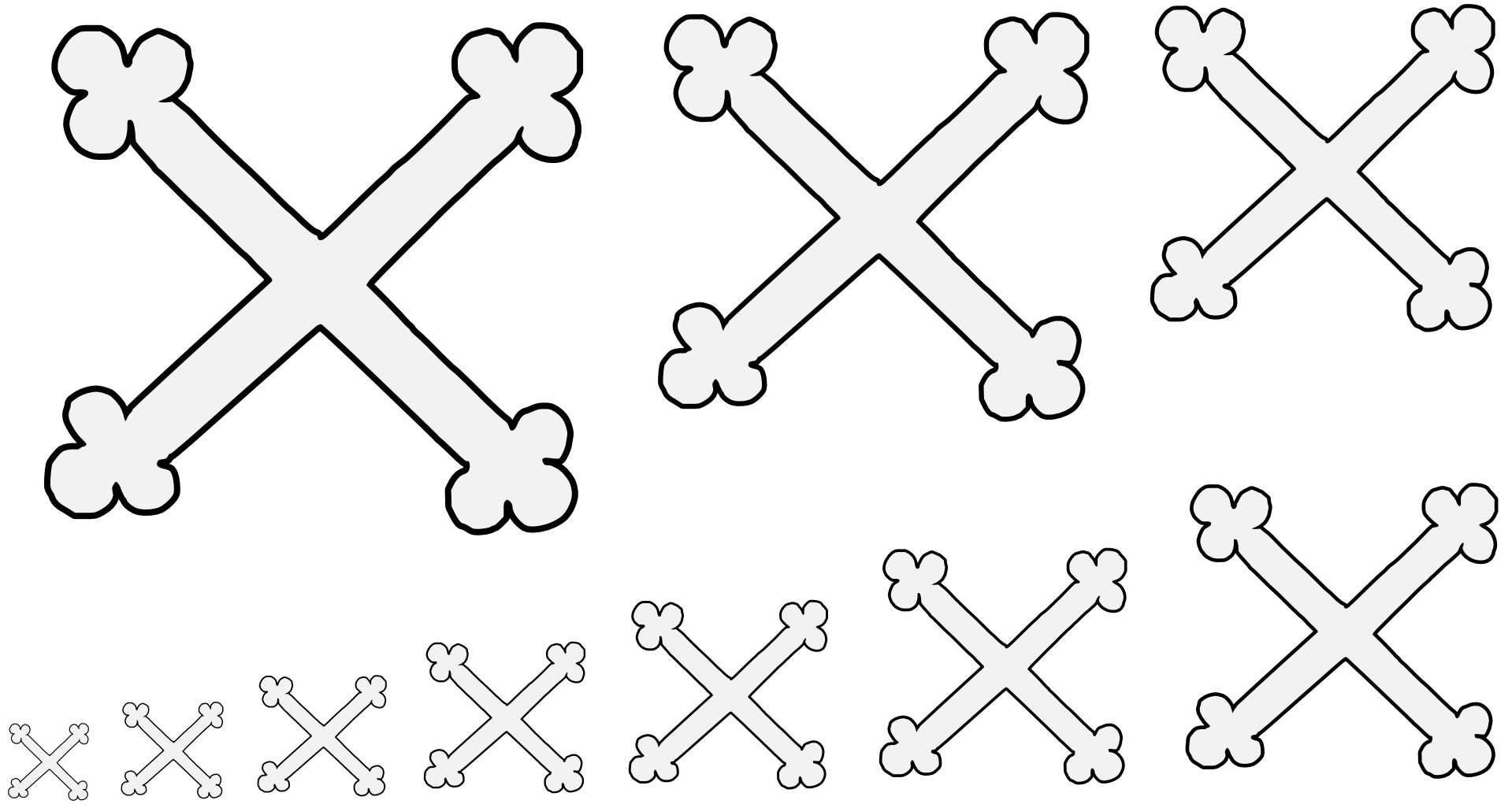

Couped ordinary.

Source: Recueil de Grand Nombre d'Écussons.
Artist unknown. (Arms of le Barbu, view 33.)

Saltire Bottony (2) 4.586

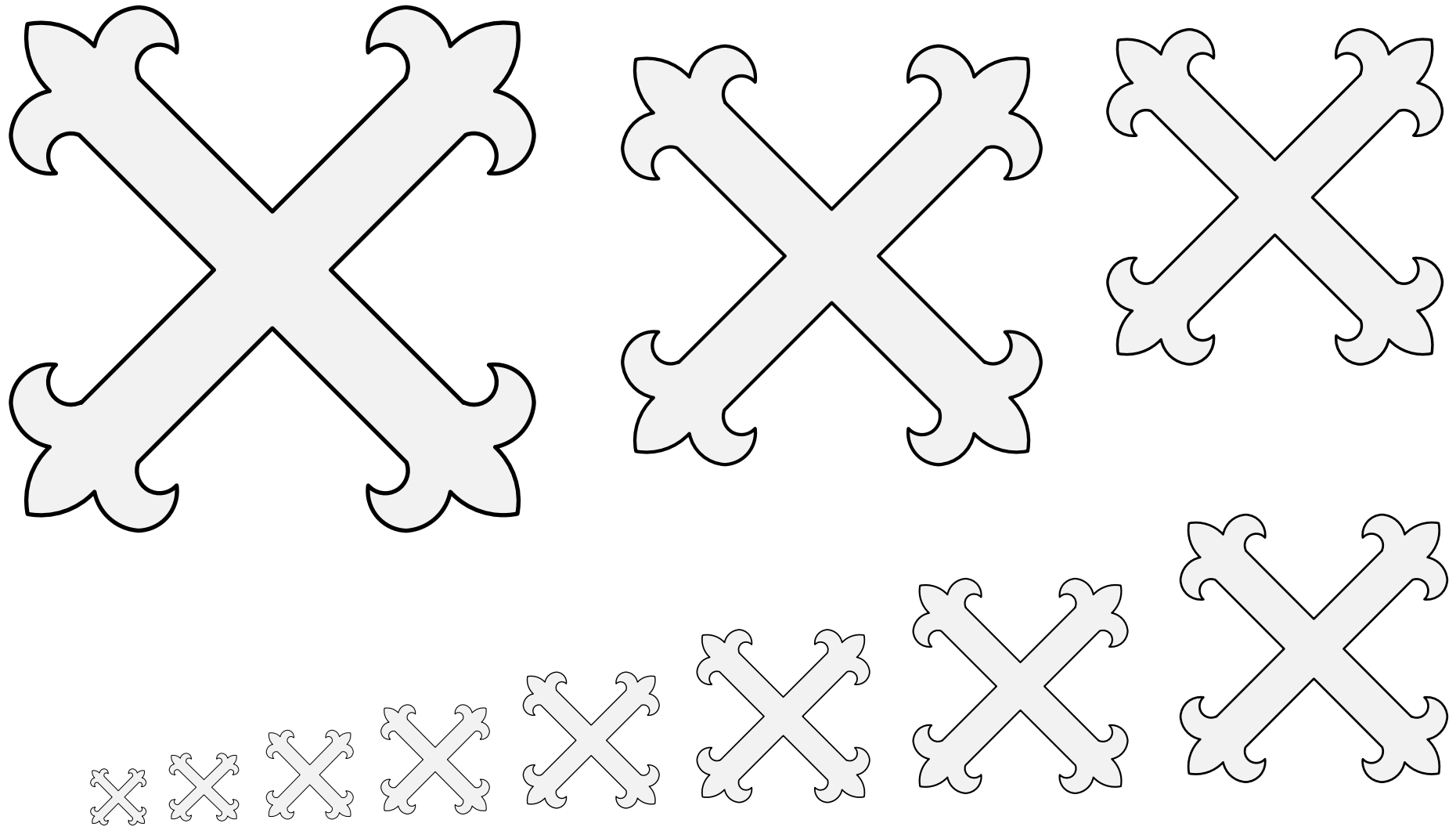

A saltire with flared ends resembling fleurs de lys.

Default orientation: saltirewise. No proper coloration.

Source: Viking Answer Lady SVG Images For Heraldry.

Artist: Gunnvôr silfrahárr. Adapted by Mathghamhain Ua Ruadháin.

Saltire Flory 4.587

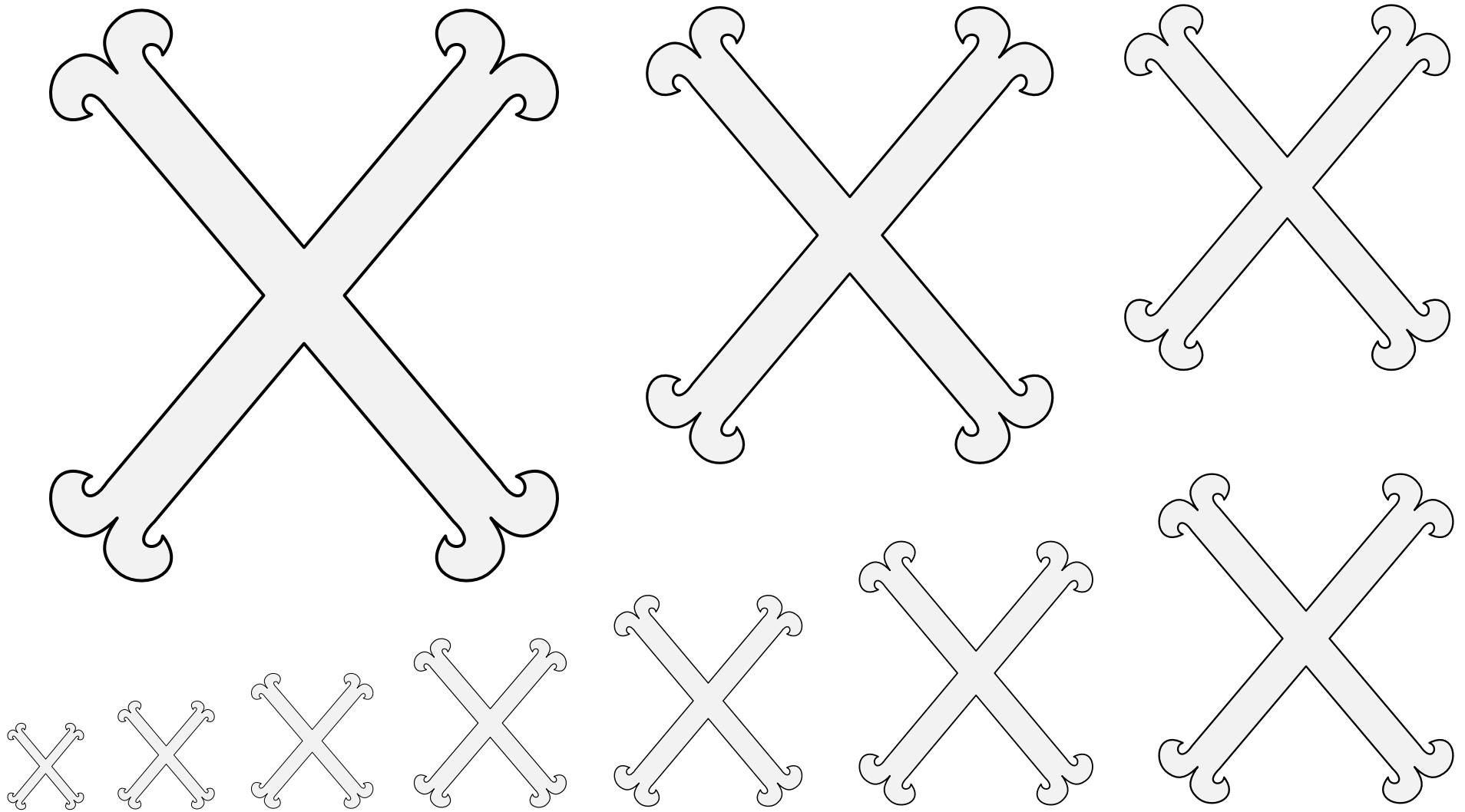

A saltire with flared ends.

Default orientation: saltirewise. No proper coloration.

Source: BnF MS Allemand 304.

Artist unknown. (Page 761.)

Saltire Moline • 4.588

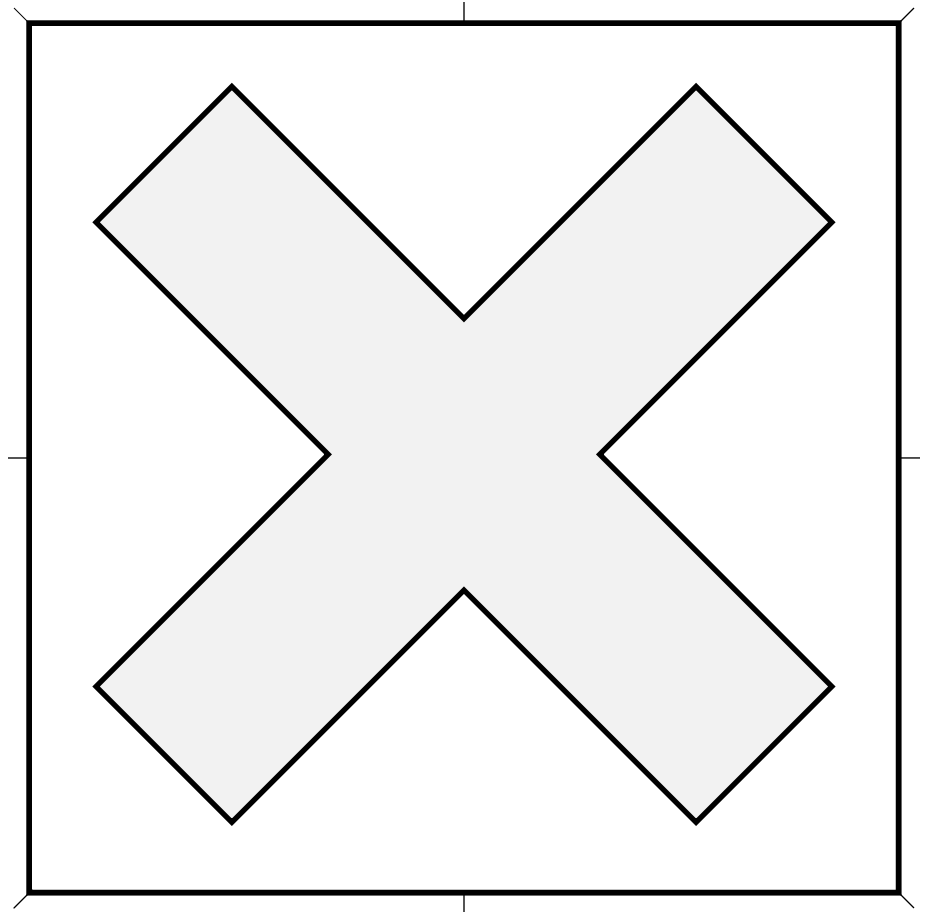
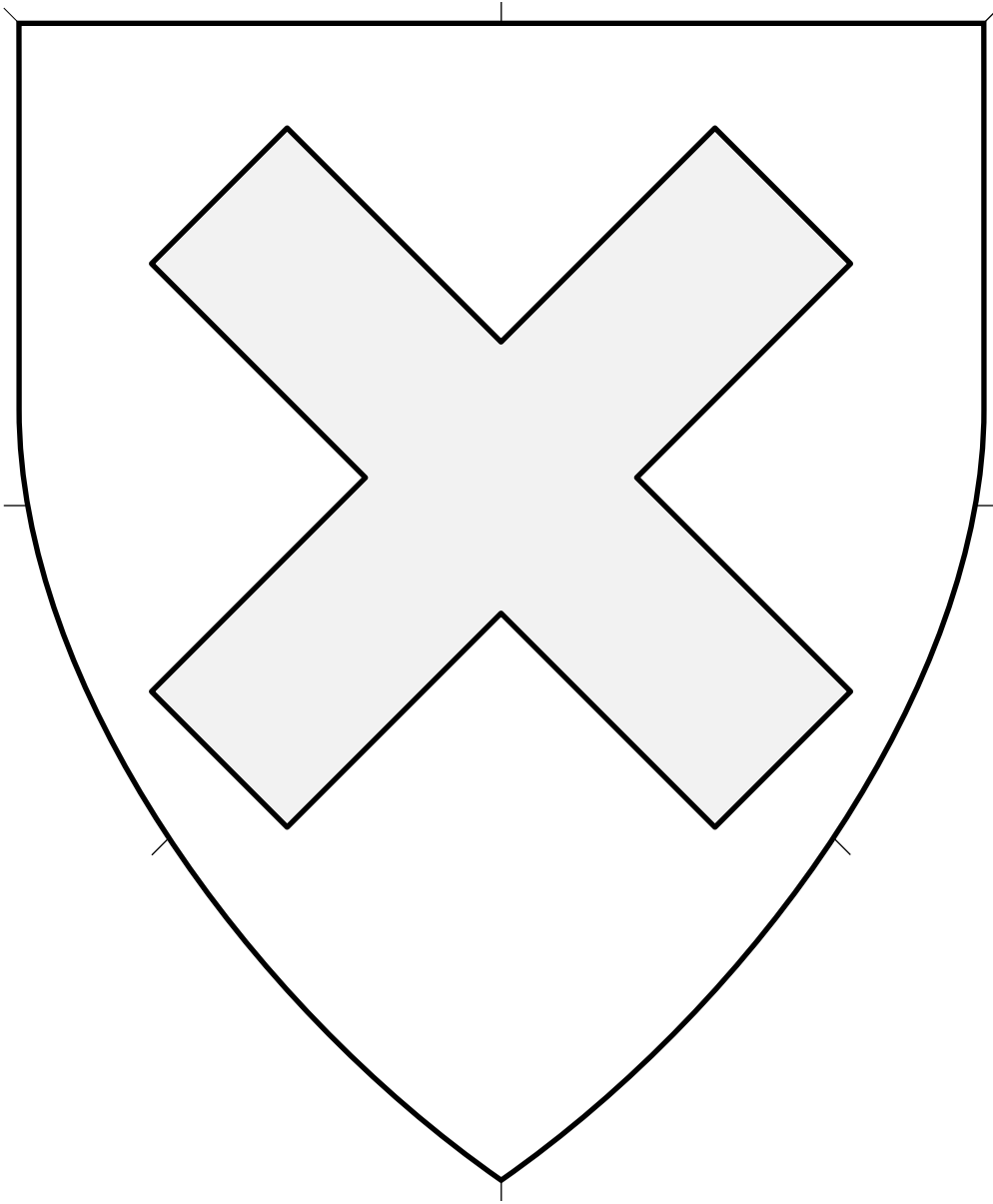

Couped ordinary.

Saltorel, or Saltire Couped 4.589

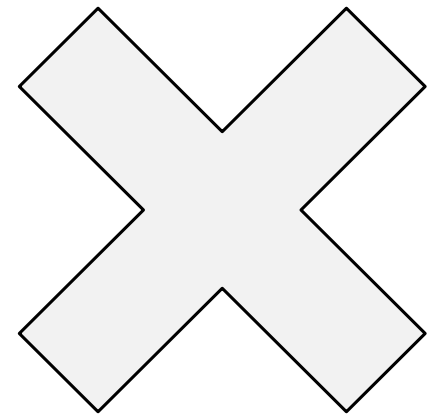
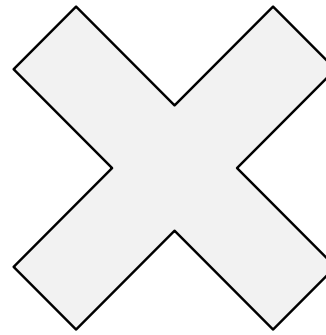
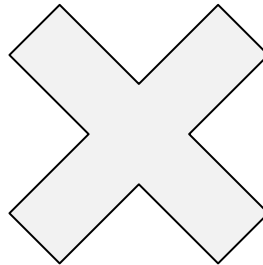
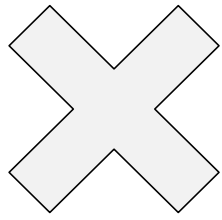
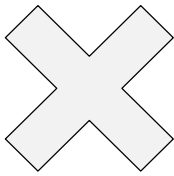
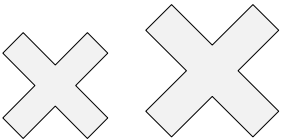
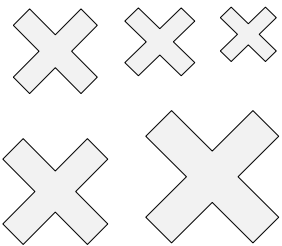
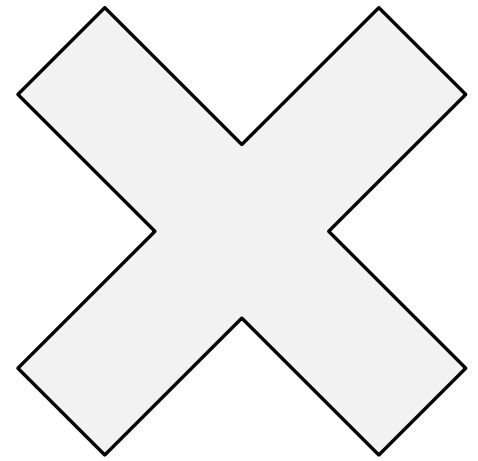
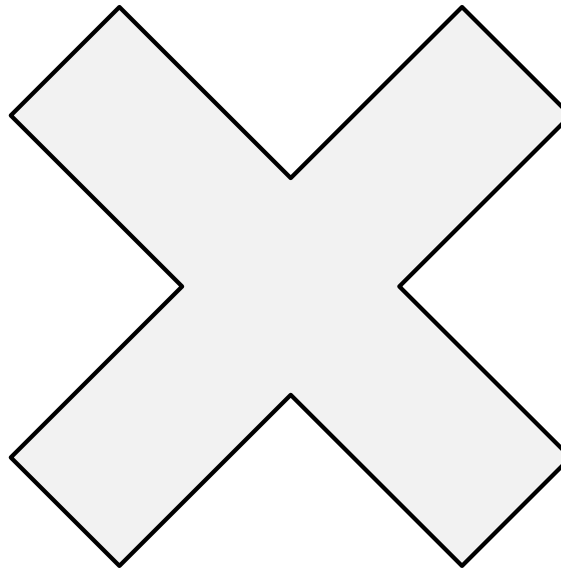
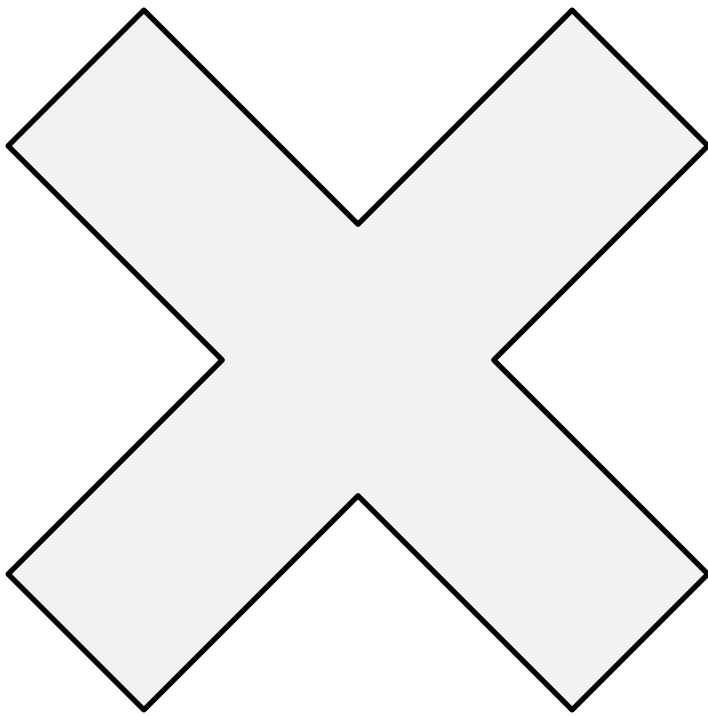

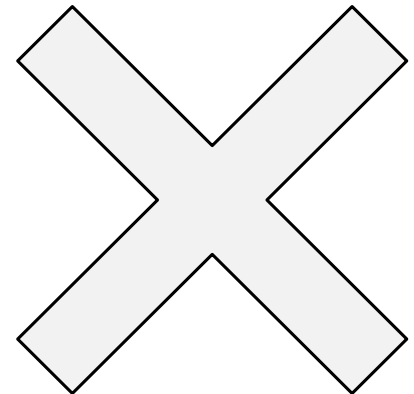
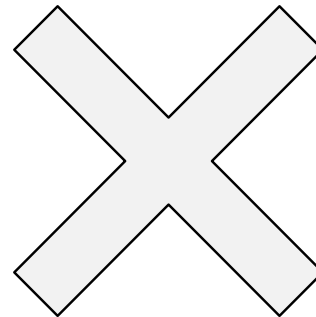
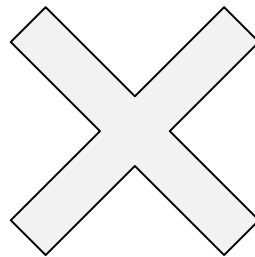
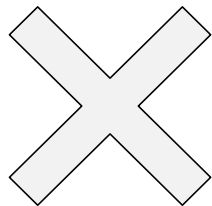
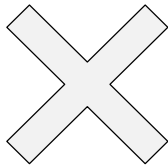
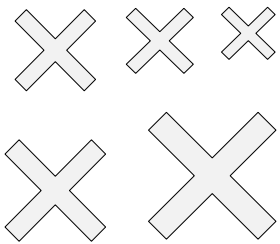
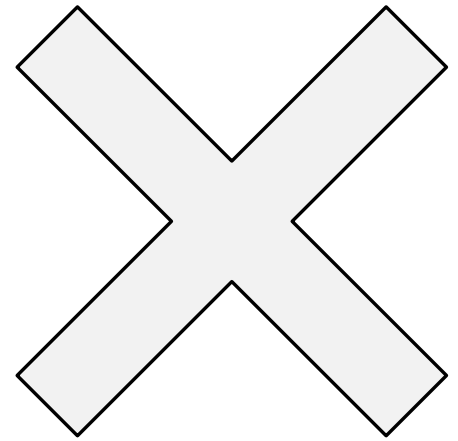
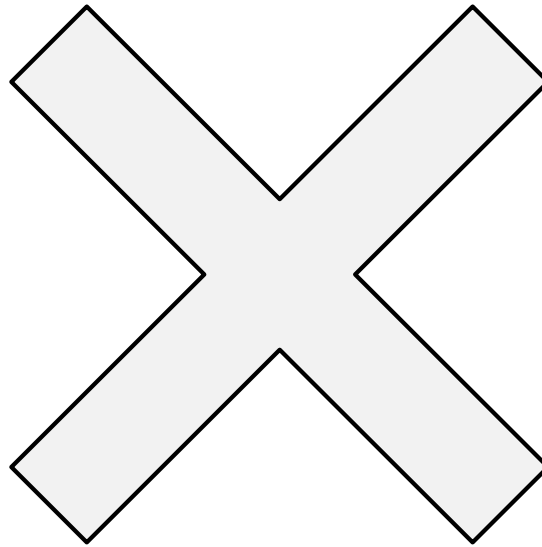
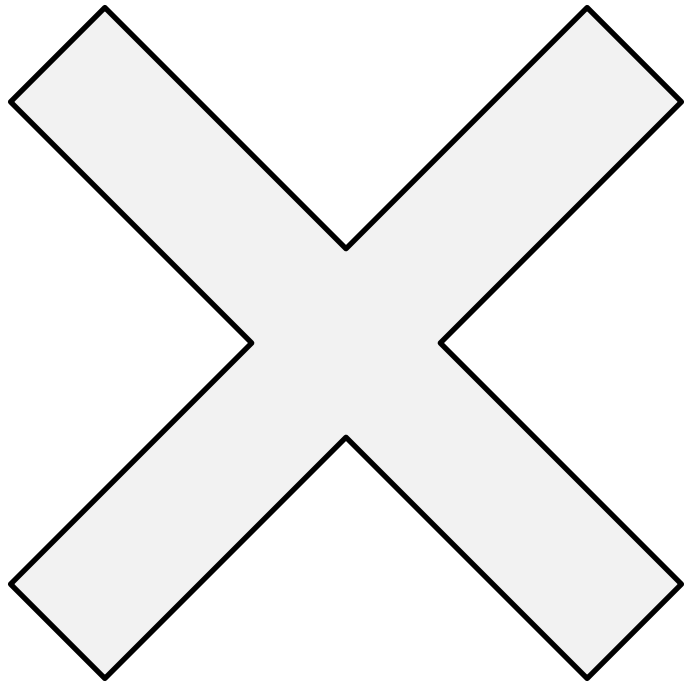

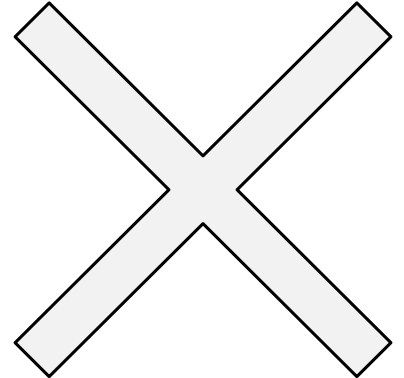
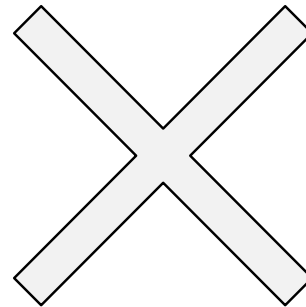
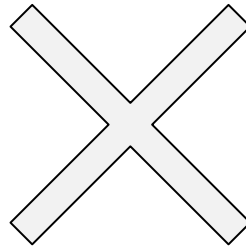
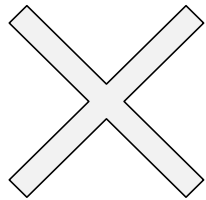
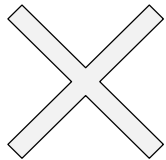
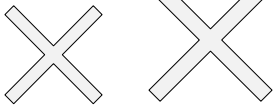
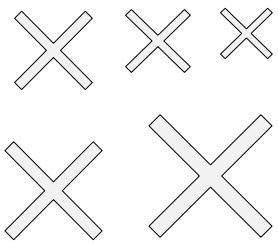
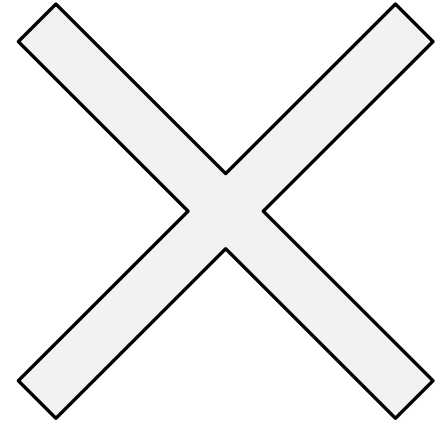
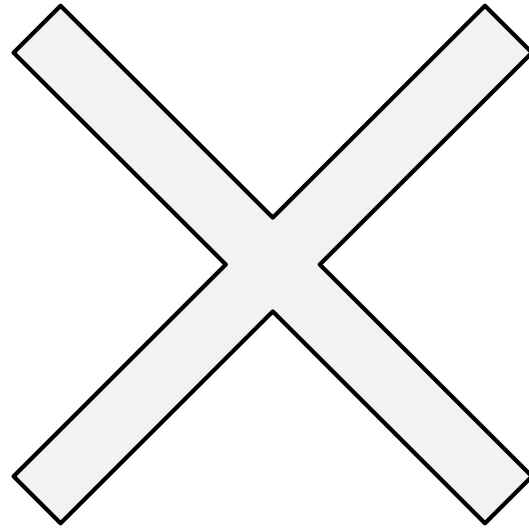
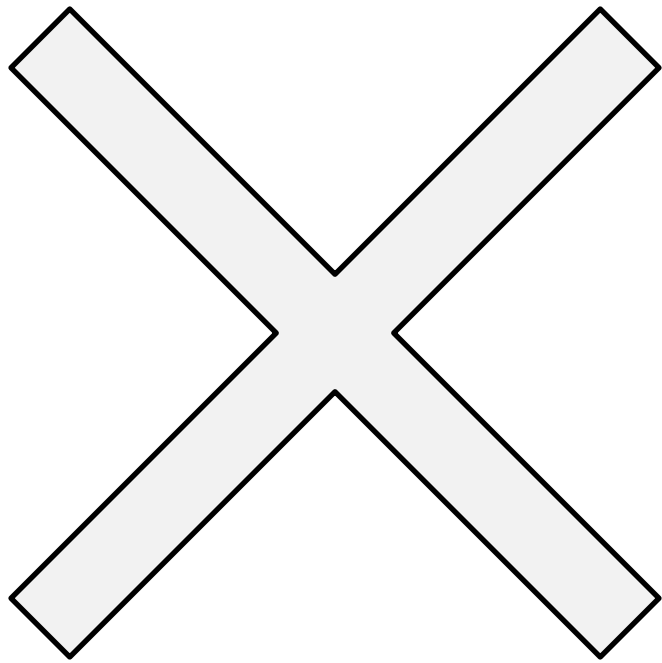

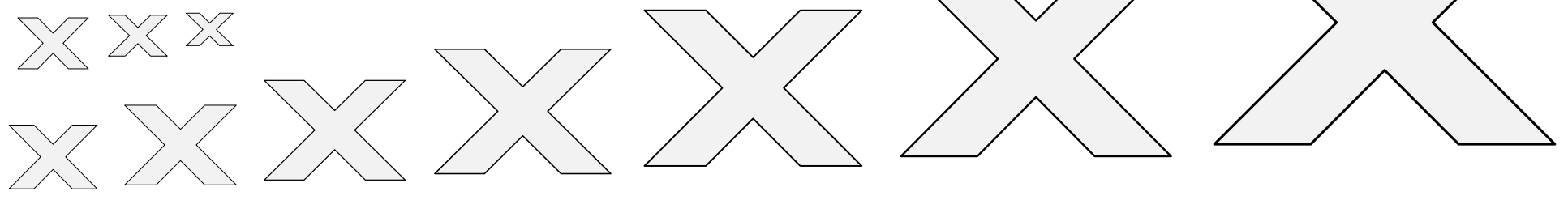
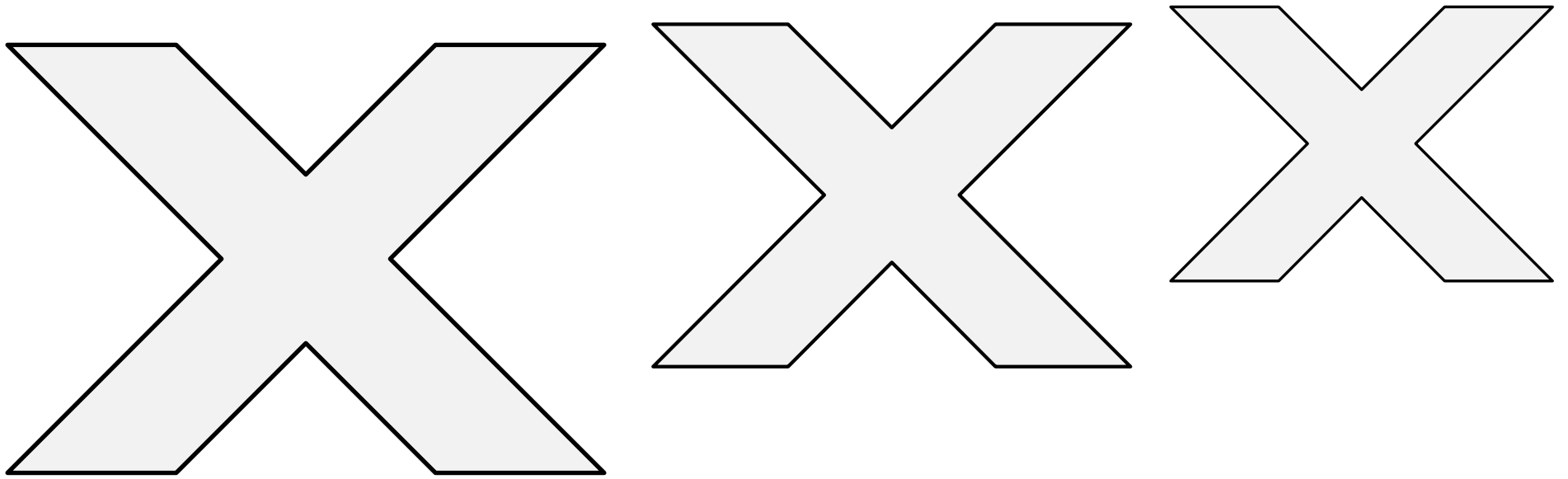

Couped ordinary.

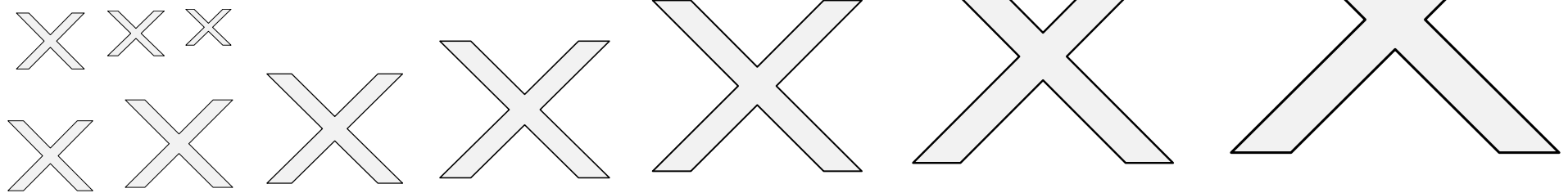
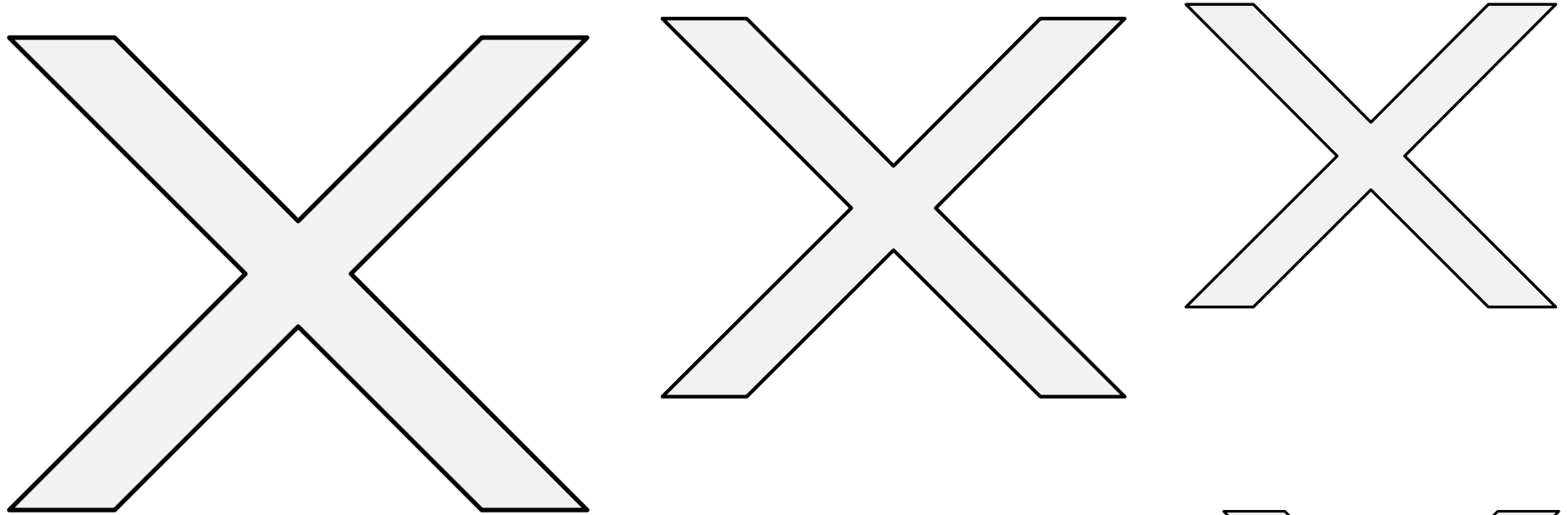

Couped ordinary.

Saltorel (6) 4.594

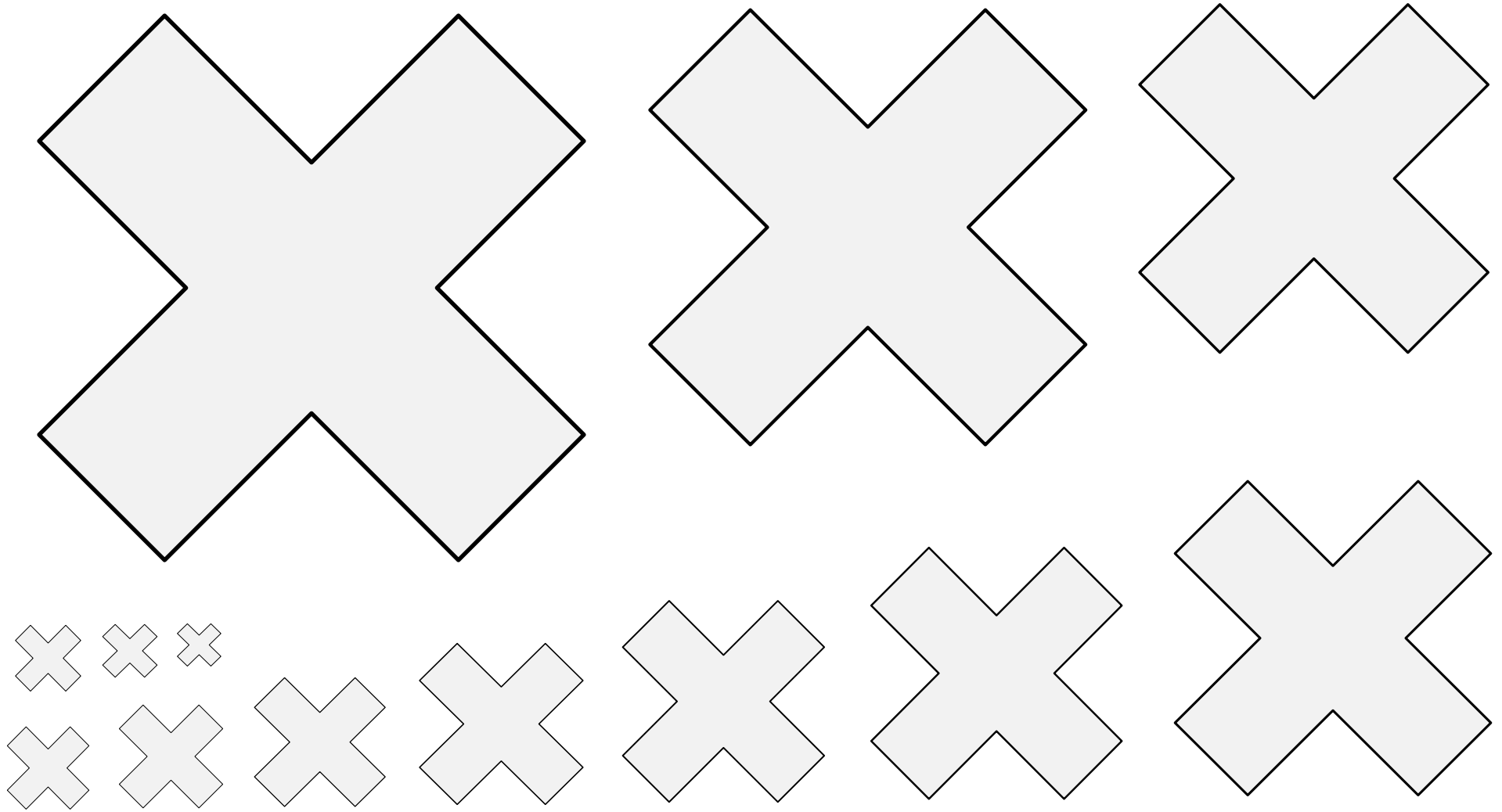

Couped ordinary.

Source: Gorrevod Armorial. Artist unknown. (Page 199.)

Saltorel (7) 4.595

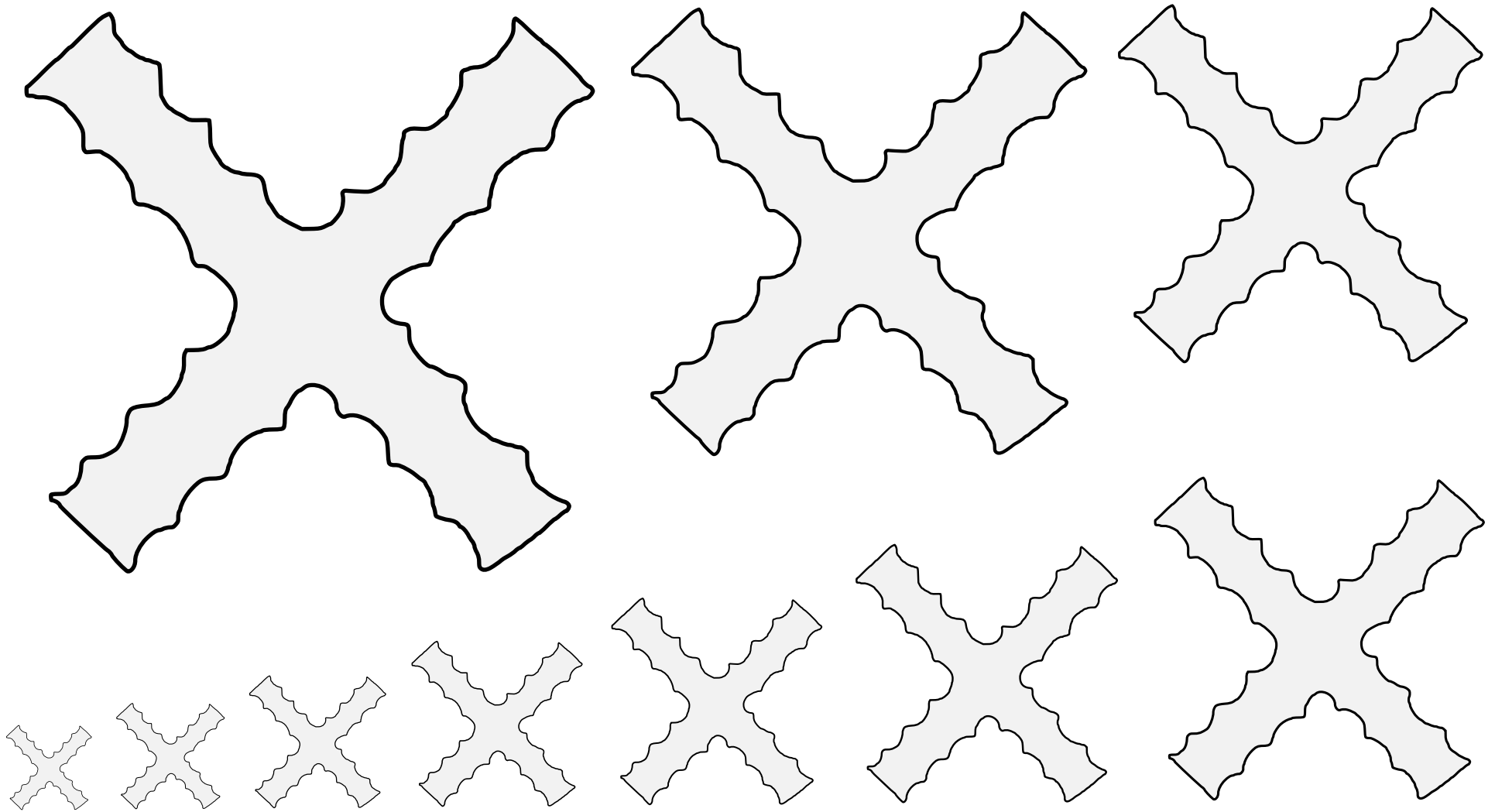

Couped ordinary.

Default orientation: saltirewise. No proper coloration.

Source: Encyclopædia Heraldica.
(Volume 3, plate XXXIV.) Artist unknown.

Saltorel Engrailed 4.596

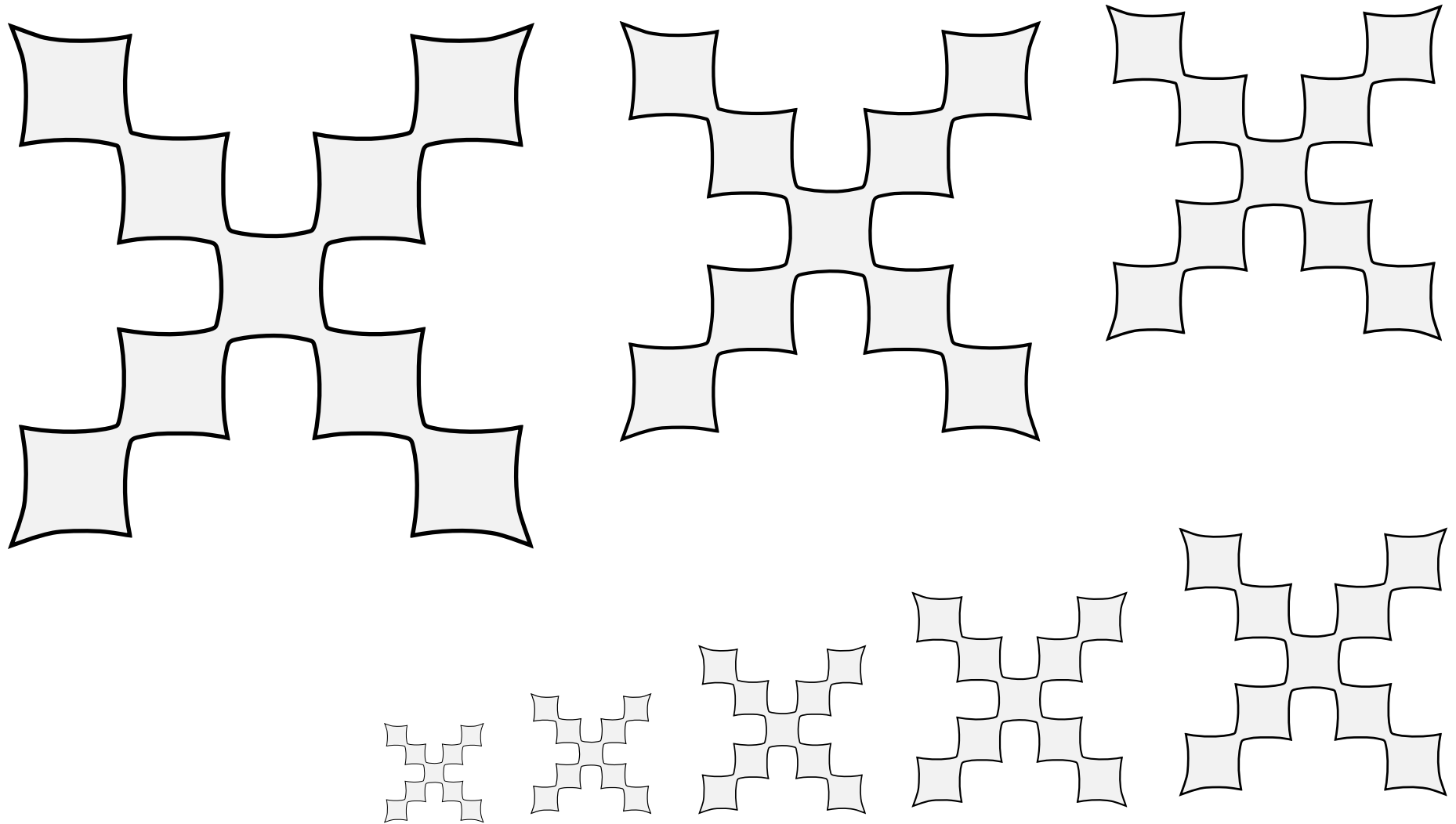

Couped ordinary.

Saltorel Fusilly 4.597

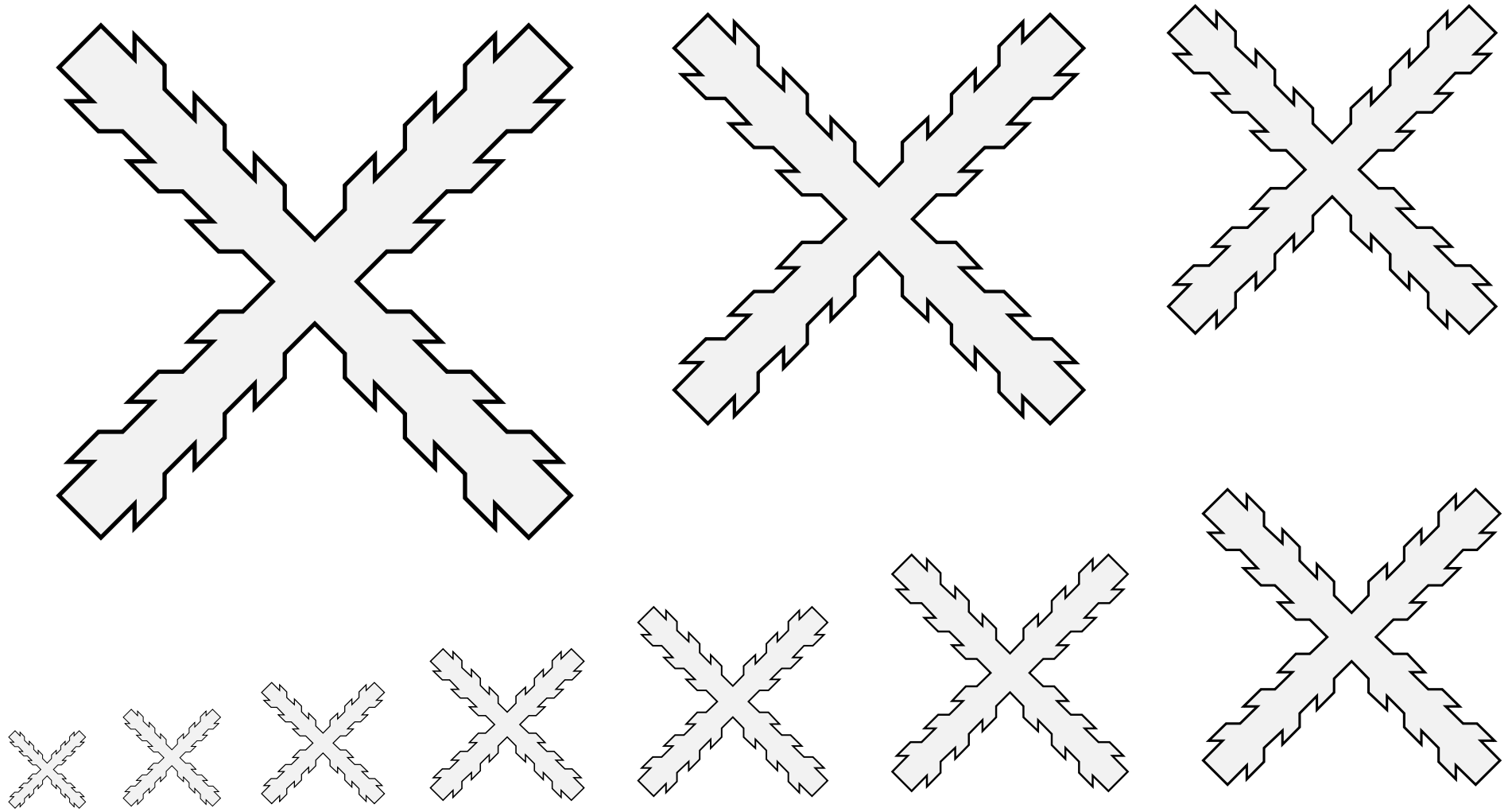

Couped ordinary.

Also called the "Burgundy cross" and used by the modern Spanish Carlists.

Saltorel Raguly 4.598

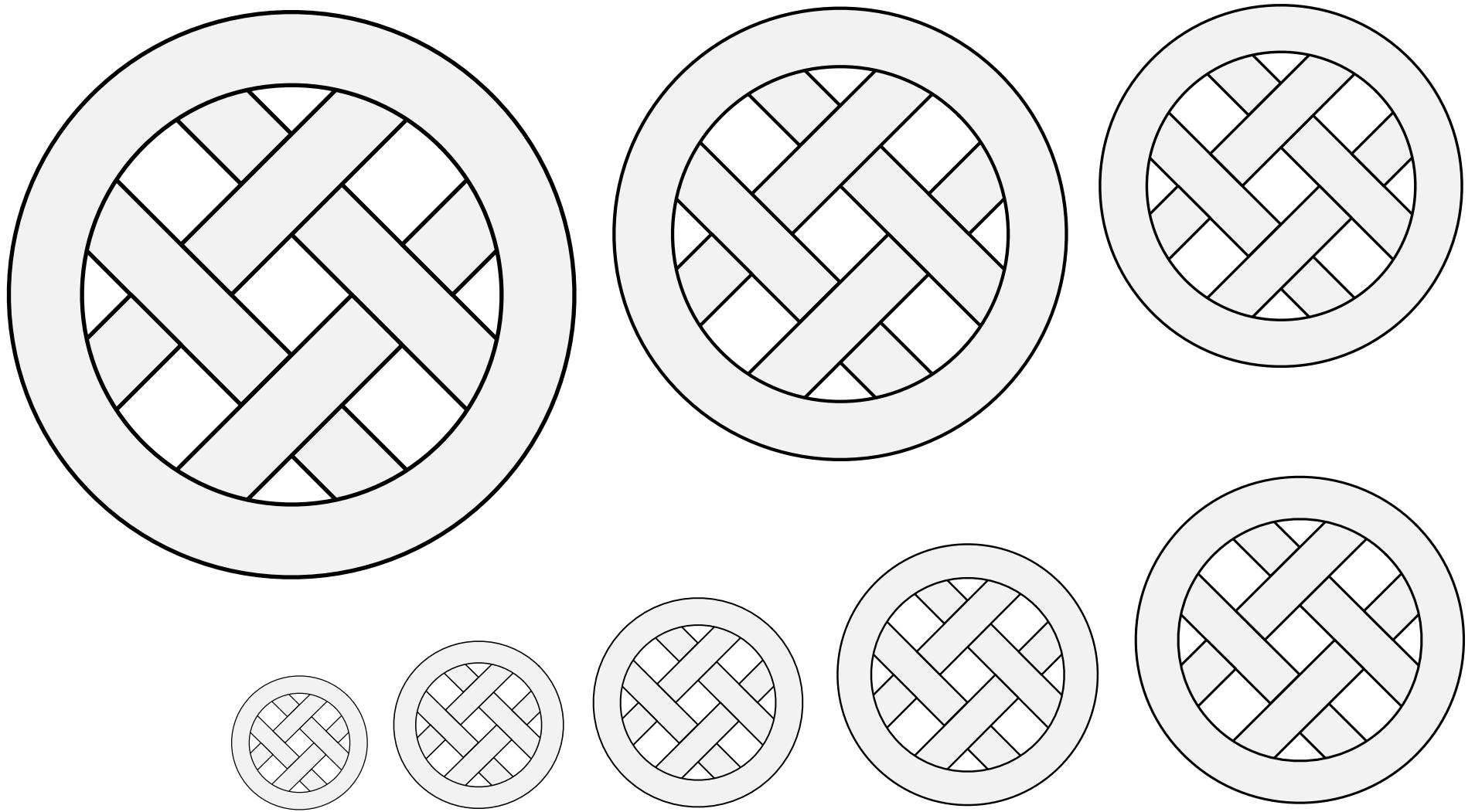

A fret within a ring.

Source: Pennsic 50 Art Tent. Artist: Sugawara Takamasa.

Saltire Couped Parted and Fretted Within an Annulet 4.599

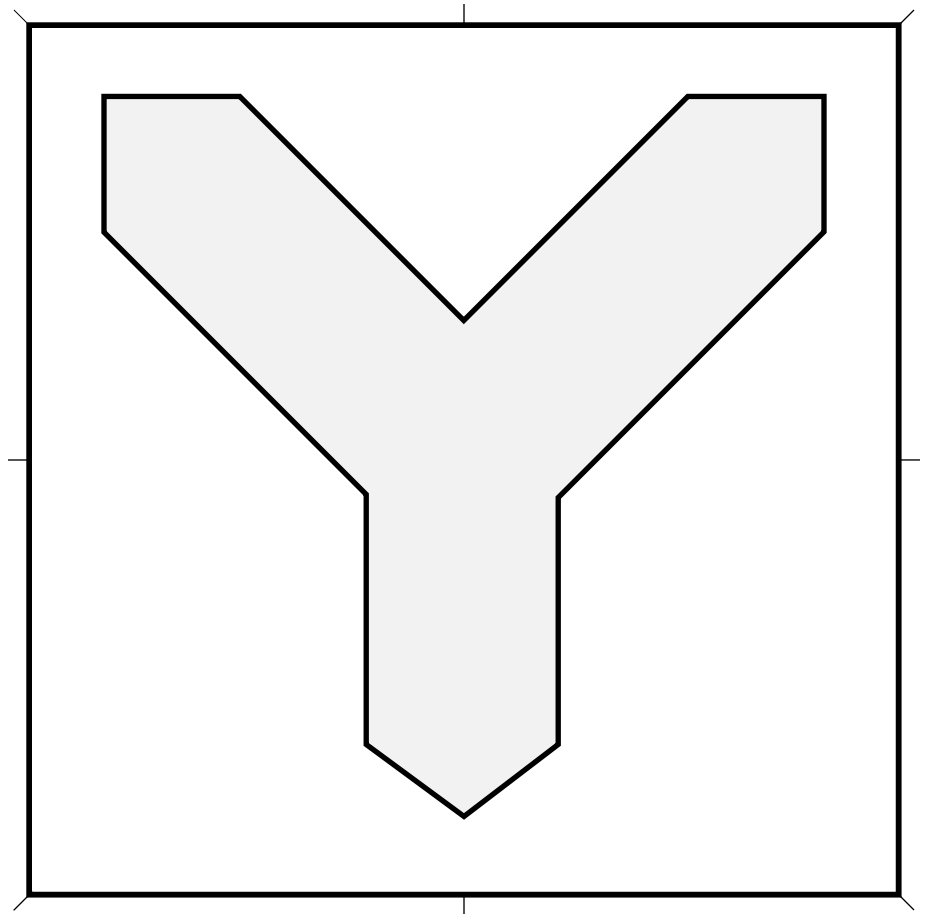
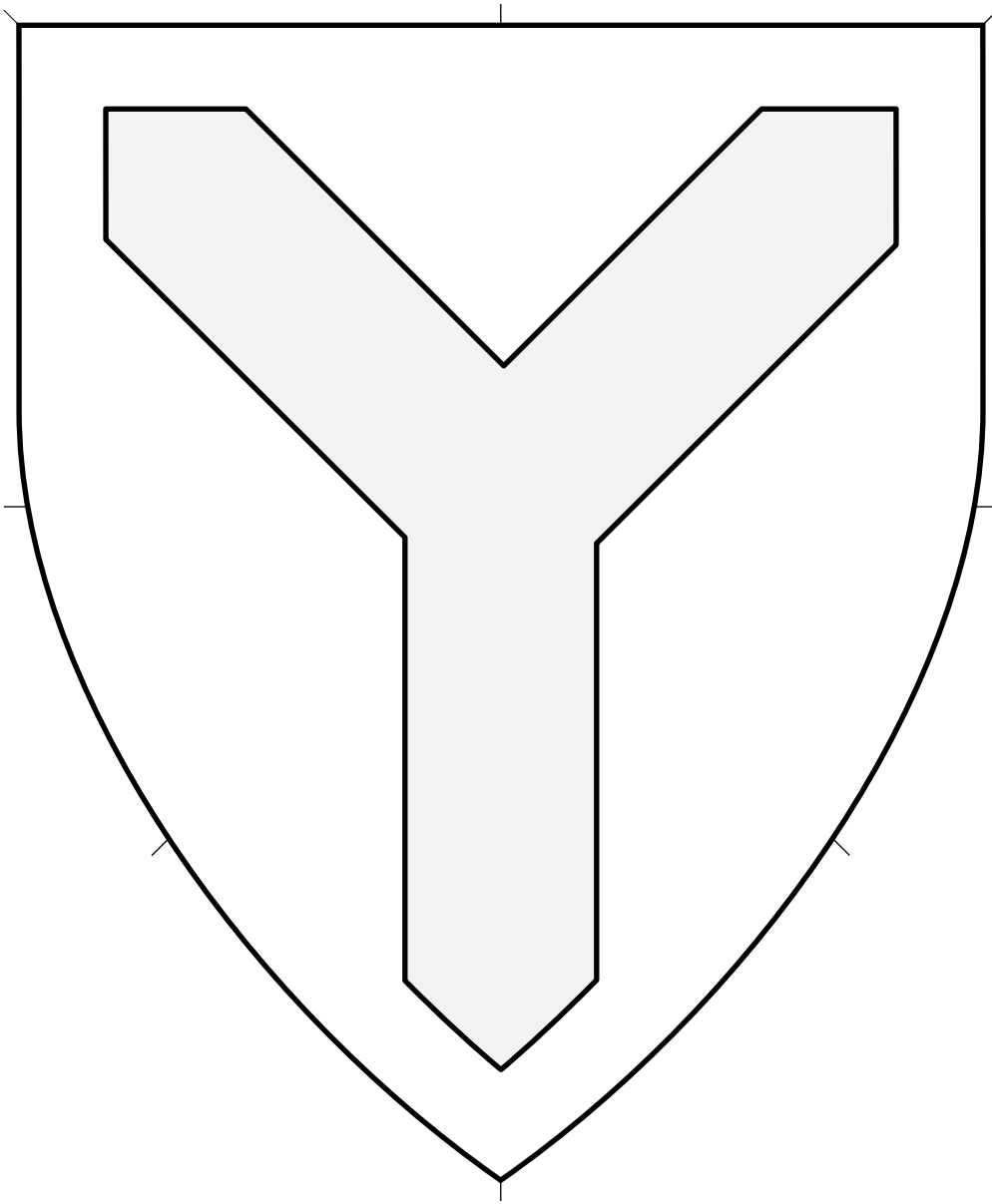

Couped ordinary. A pall couped and pointed.
The width of each arm is typically a third of the width of the device or a bit narrower.

Shakefork (1) 4.600

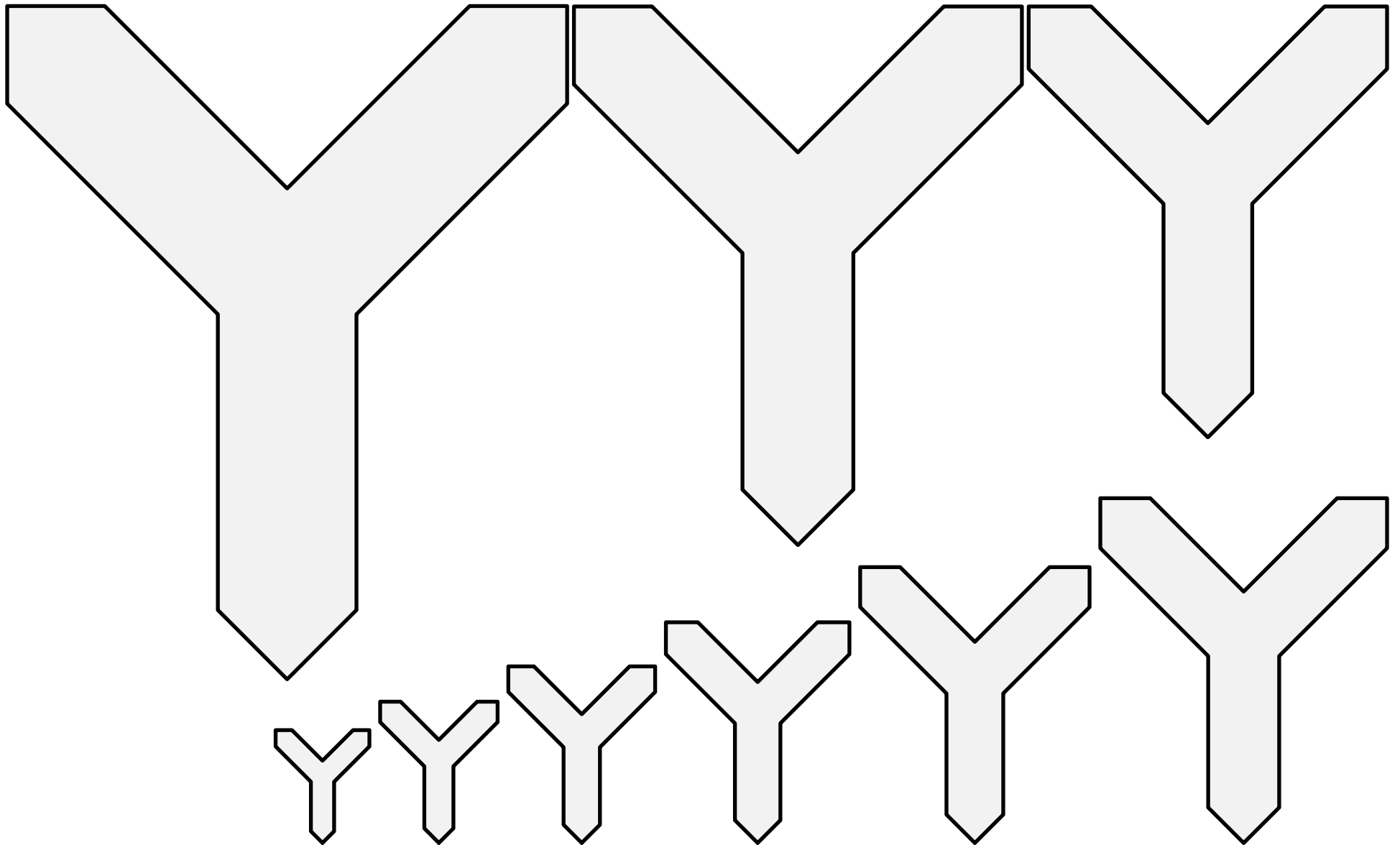

Couped ordinary.

Shakefork (2) 4.601

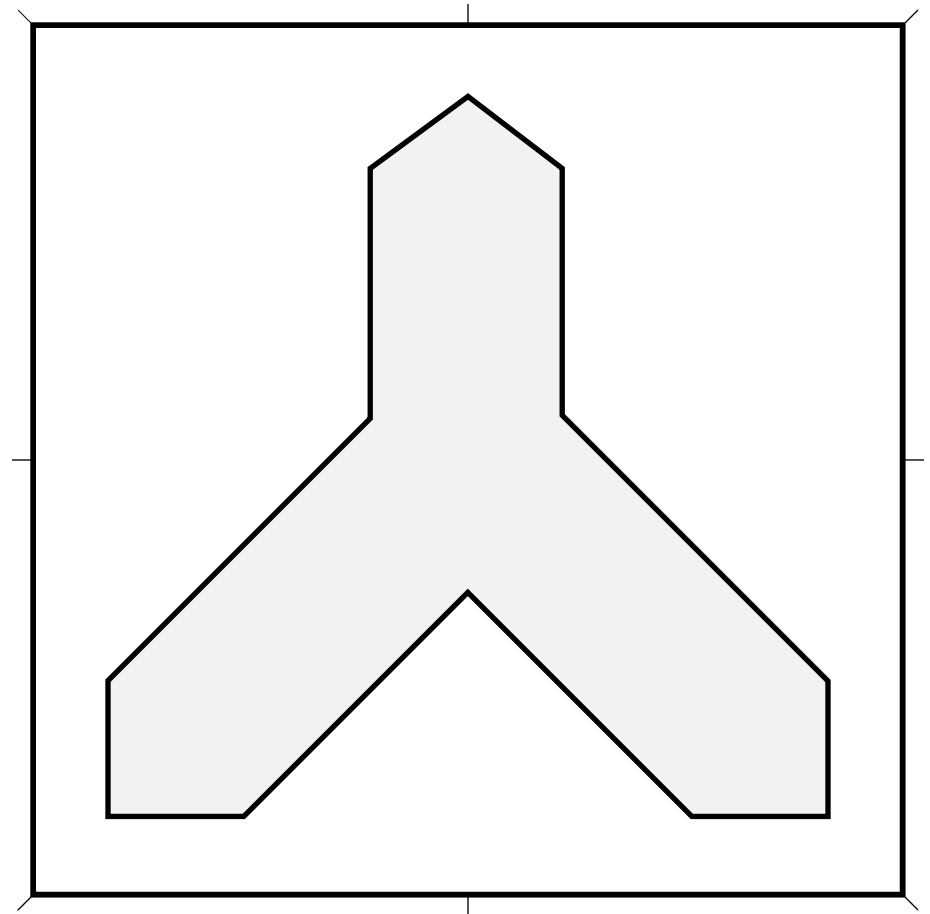
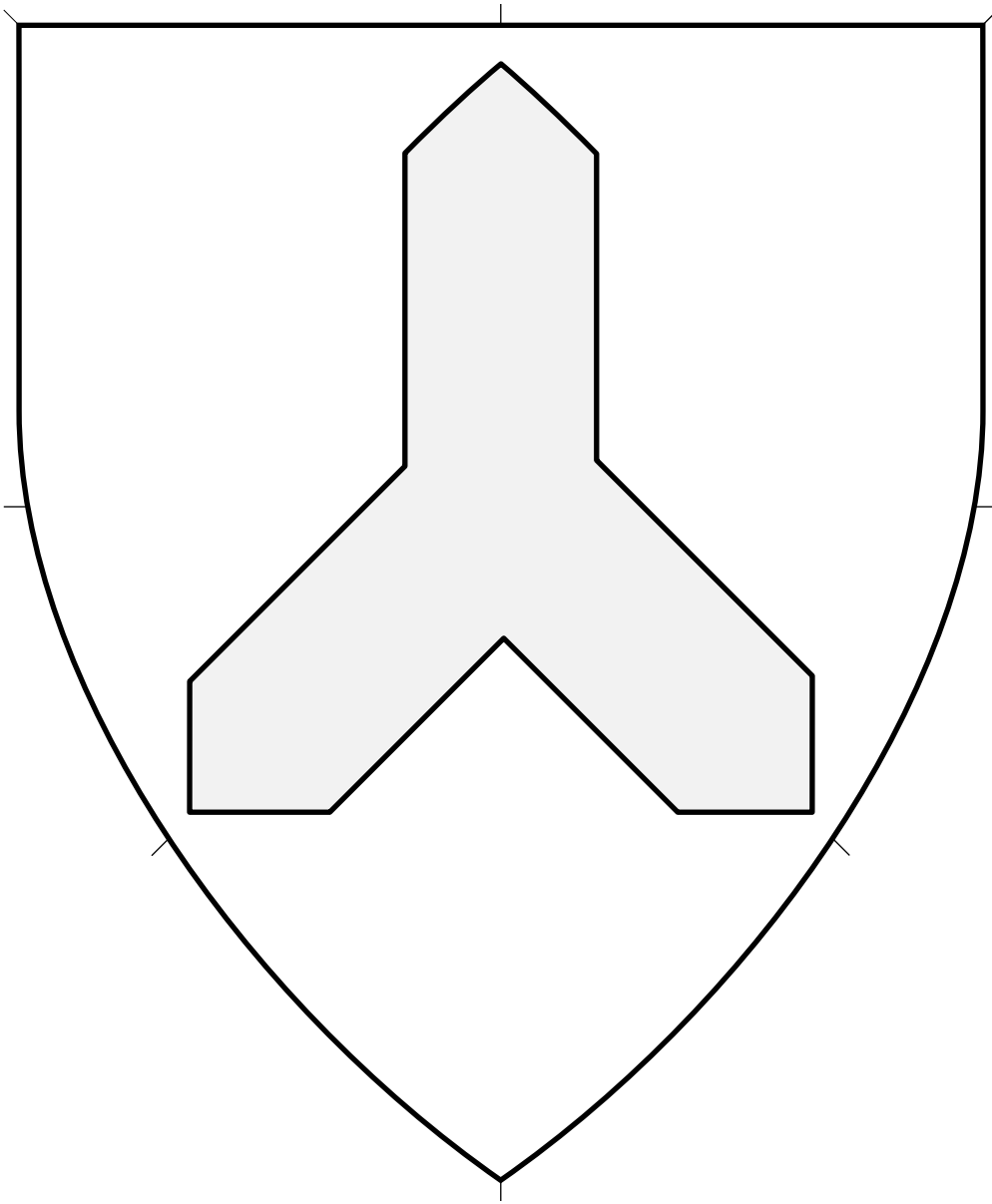

Couped ordinary. A pale inverted couped and pointed.
The width of each arm is typically a third of the width of the device or a bit narrower.

Shakefork Inverted • 4.602

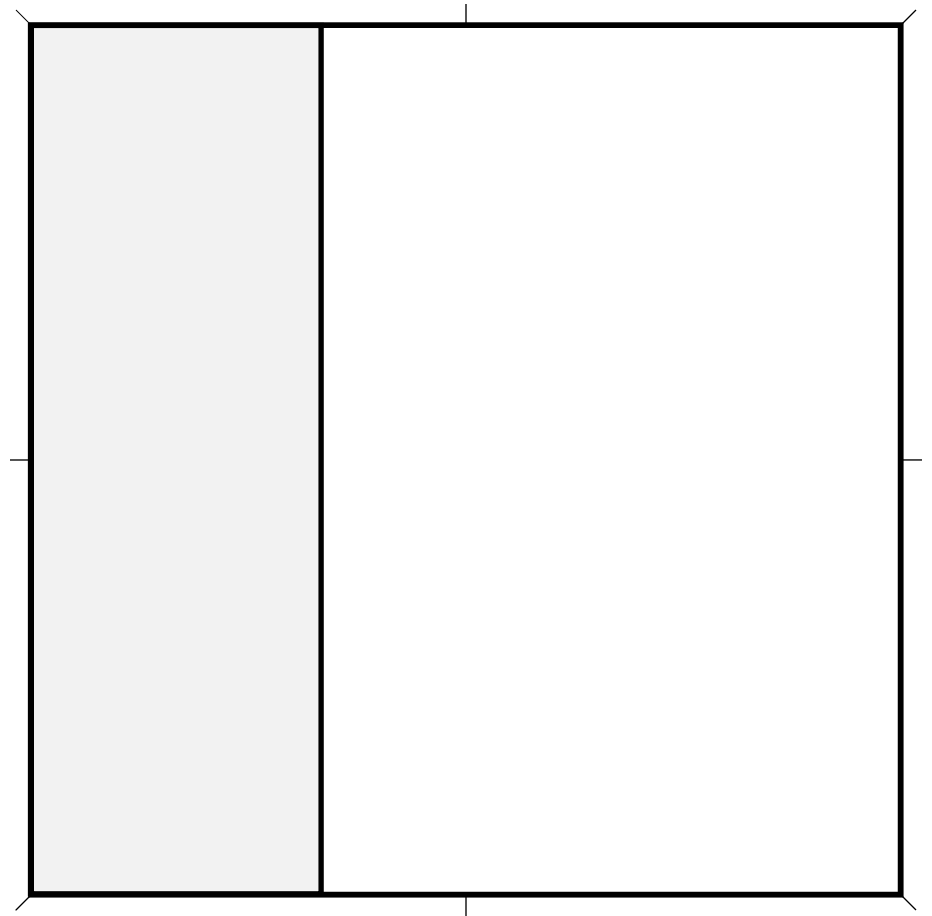
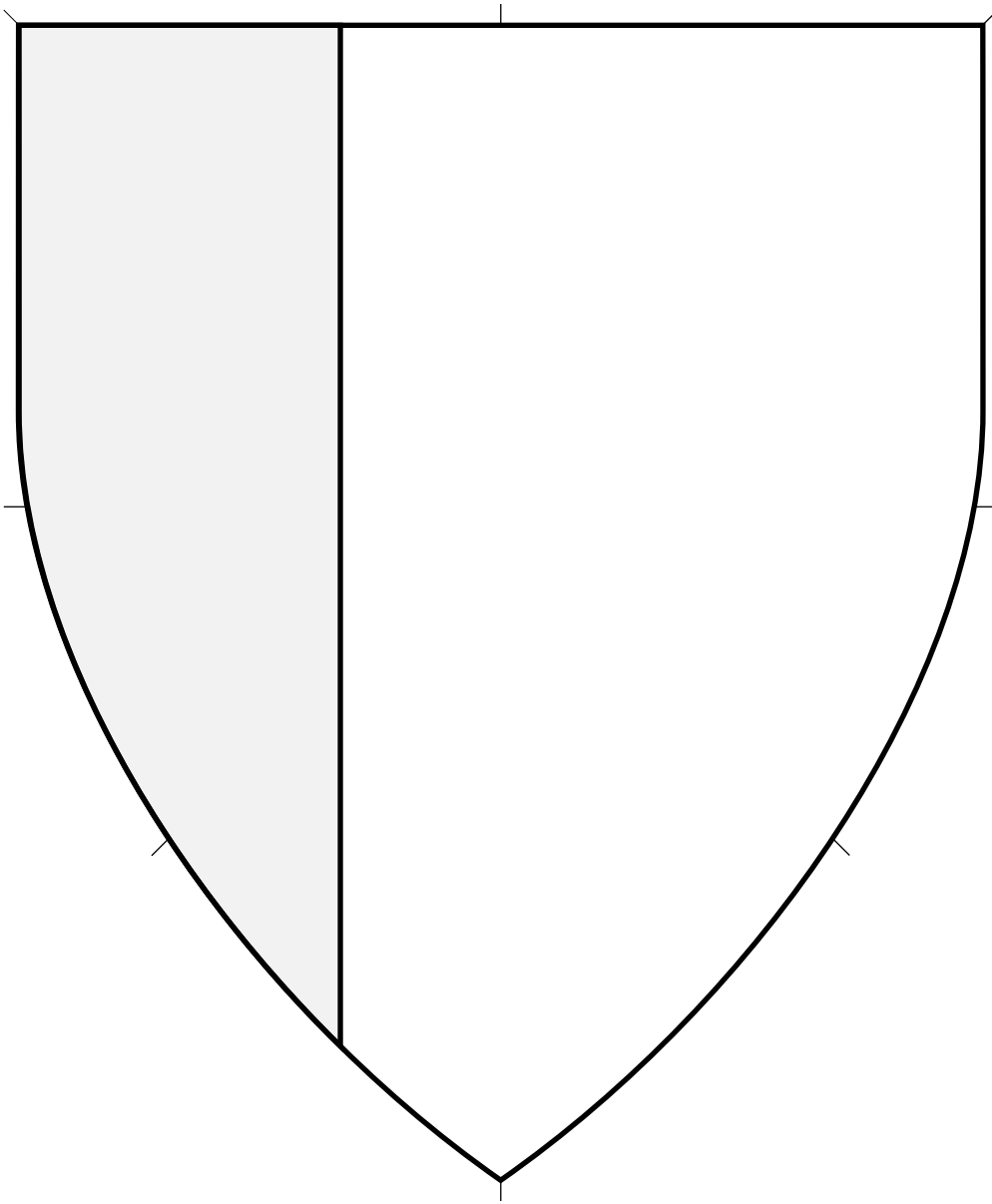

Peripheral ordinary.

May not be charged if using a plain line as shown here. A charged tierce with a complex line is registrable but would be considered a step from core practice (SFCP).

Tierce 4.603

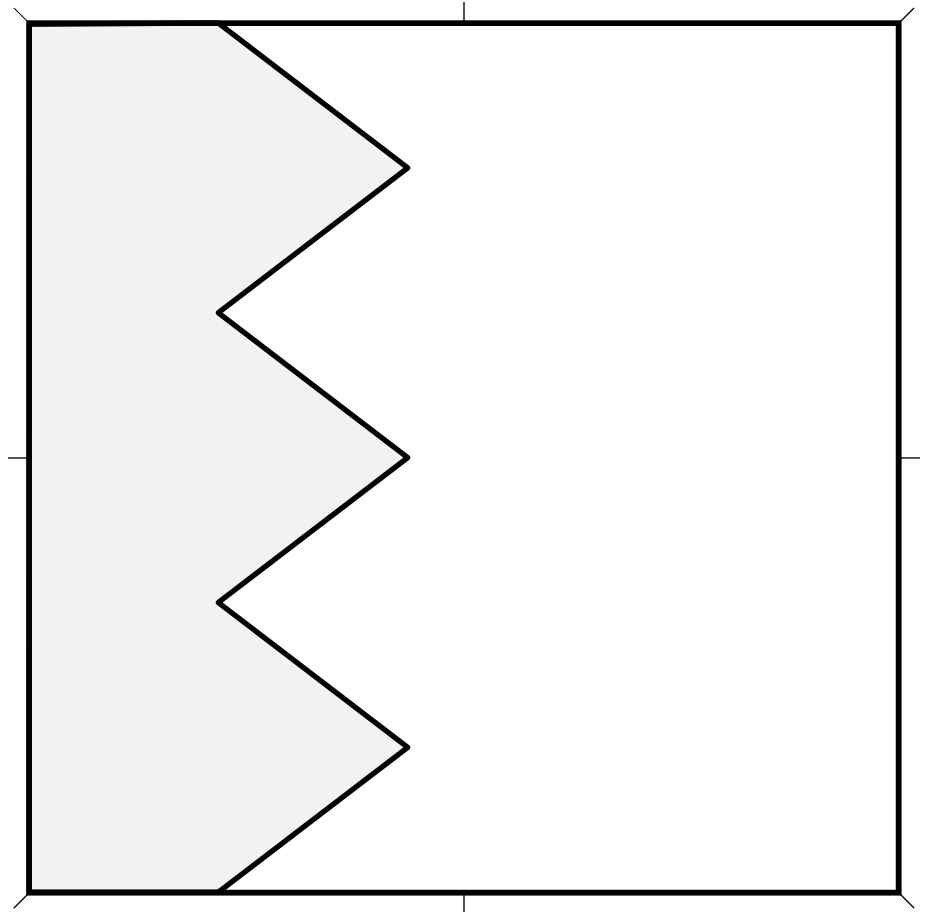
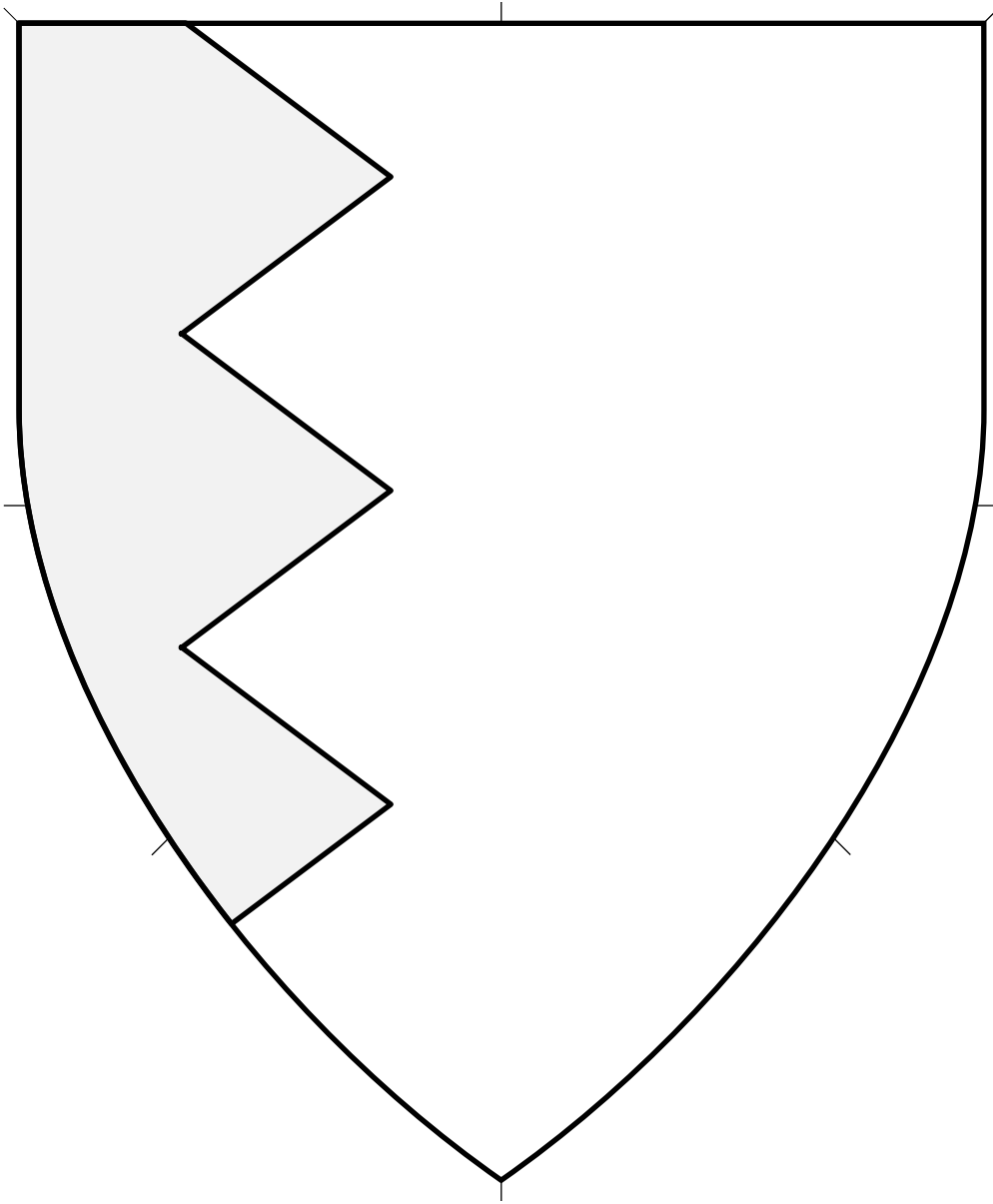

Peripheral ordinary.

Source: BnF MS Allemand 304. Artist unknown. (Page 488.)

Tierce Indented • 4.604

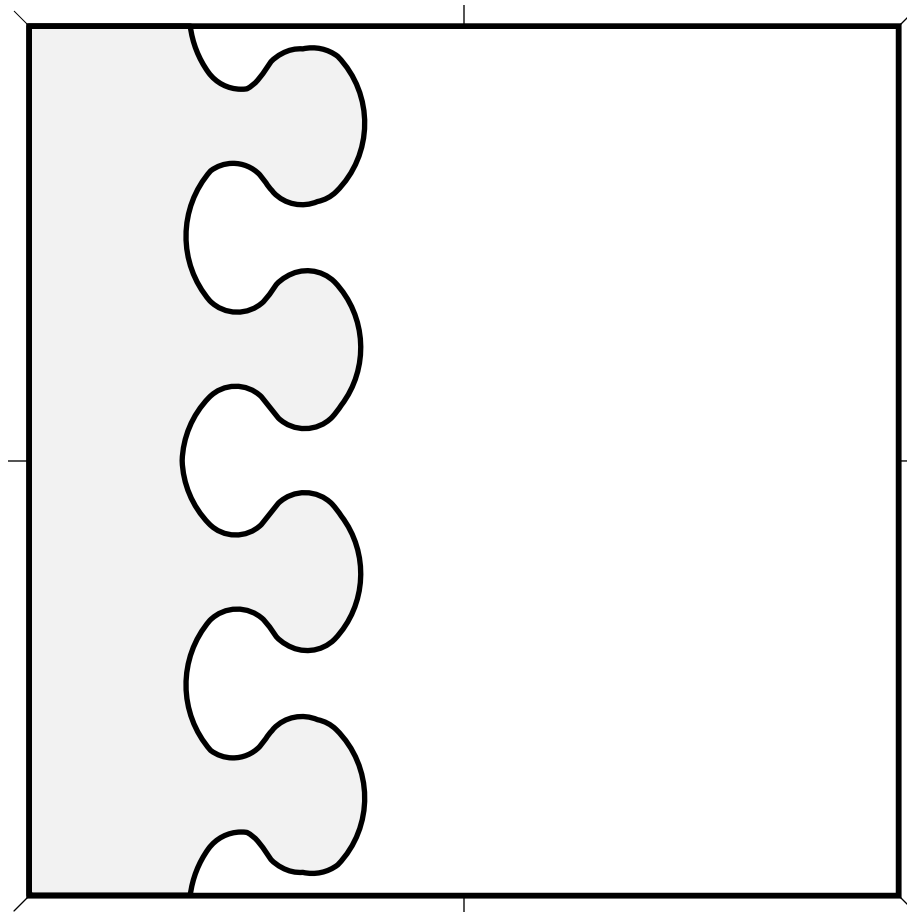
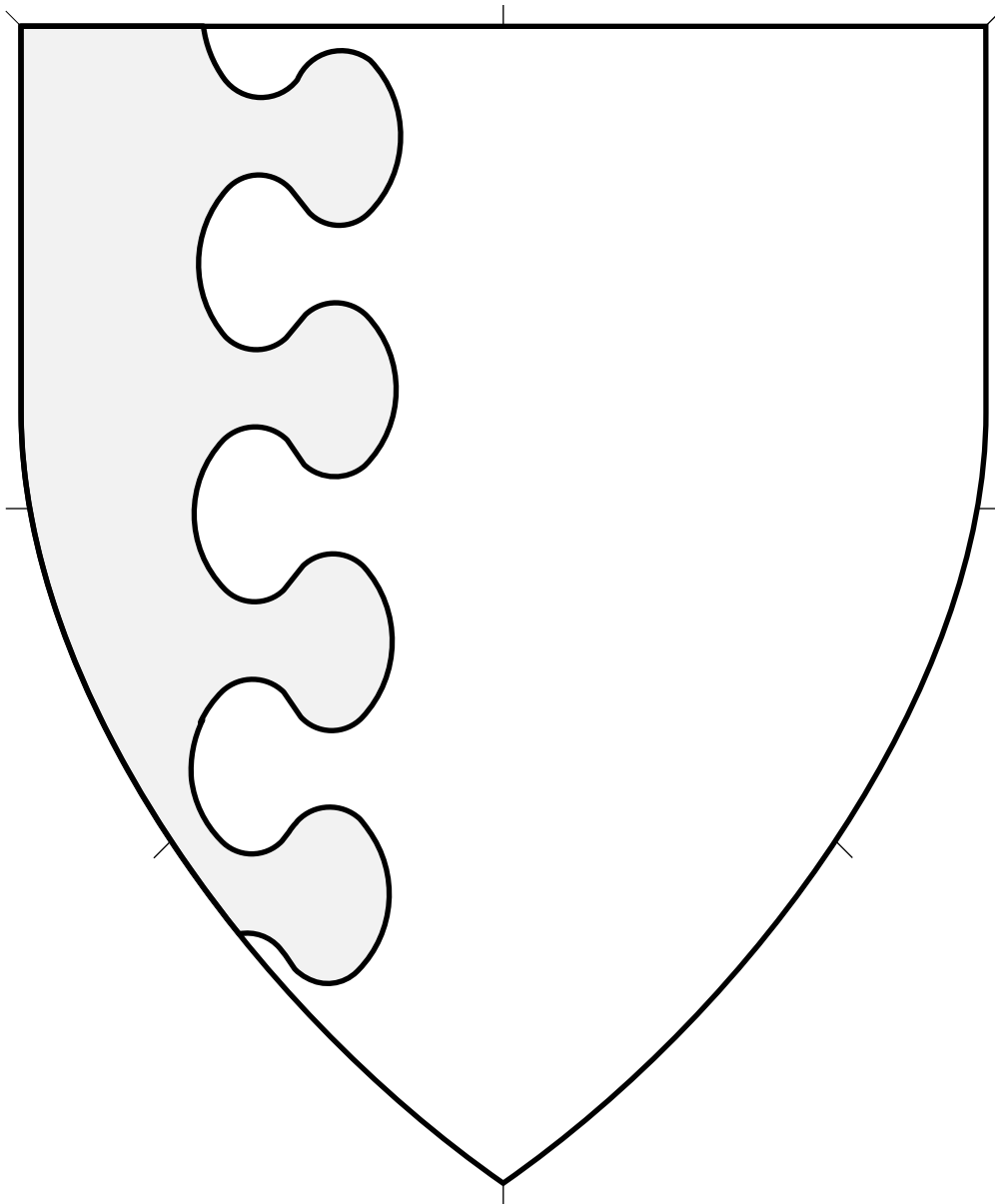

Peripheral ordinary.

Source: Viking Answer Lady SVG Images For Heraldry.
Artist: Gunnvôr silfrahárr. Adapted by Mathghamhain Ua Ruadháin.

Tierce Nebuly (1) 4.605

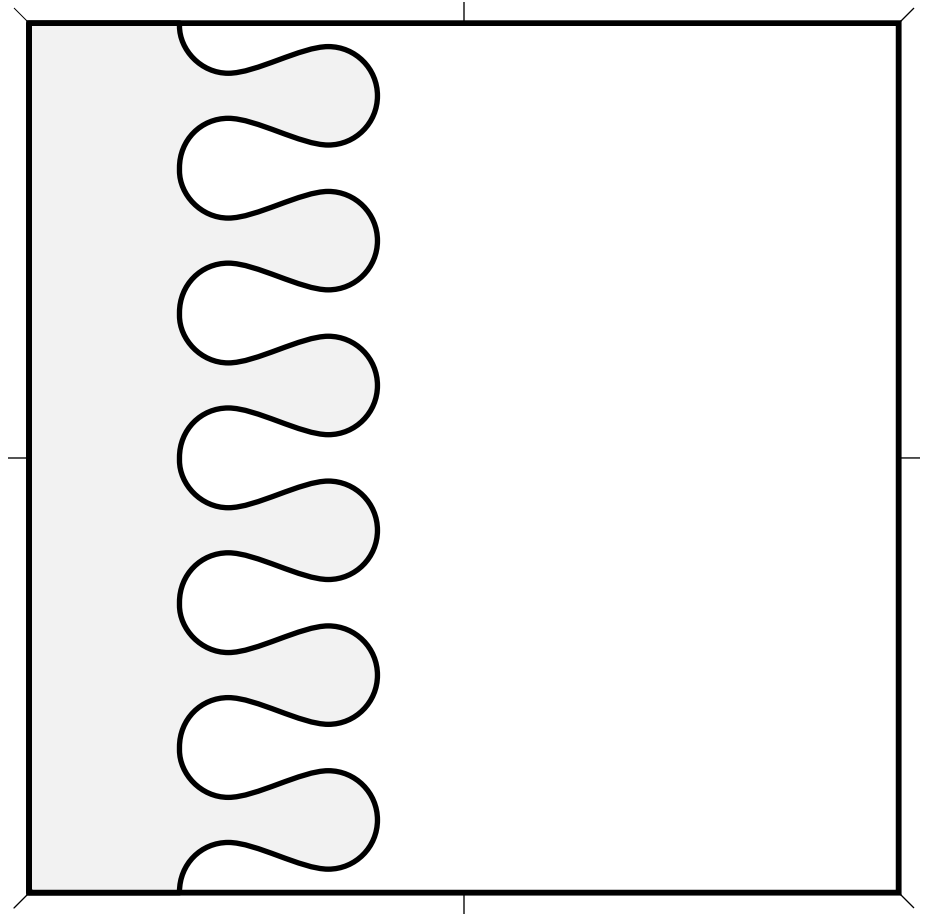
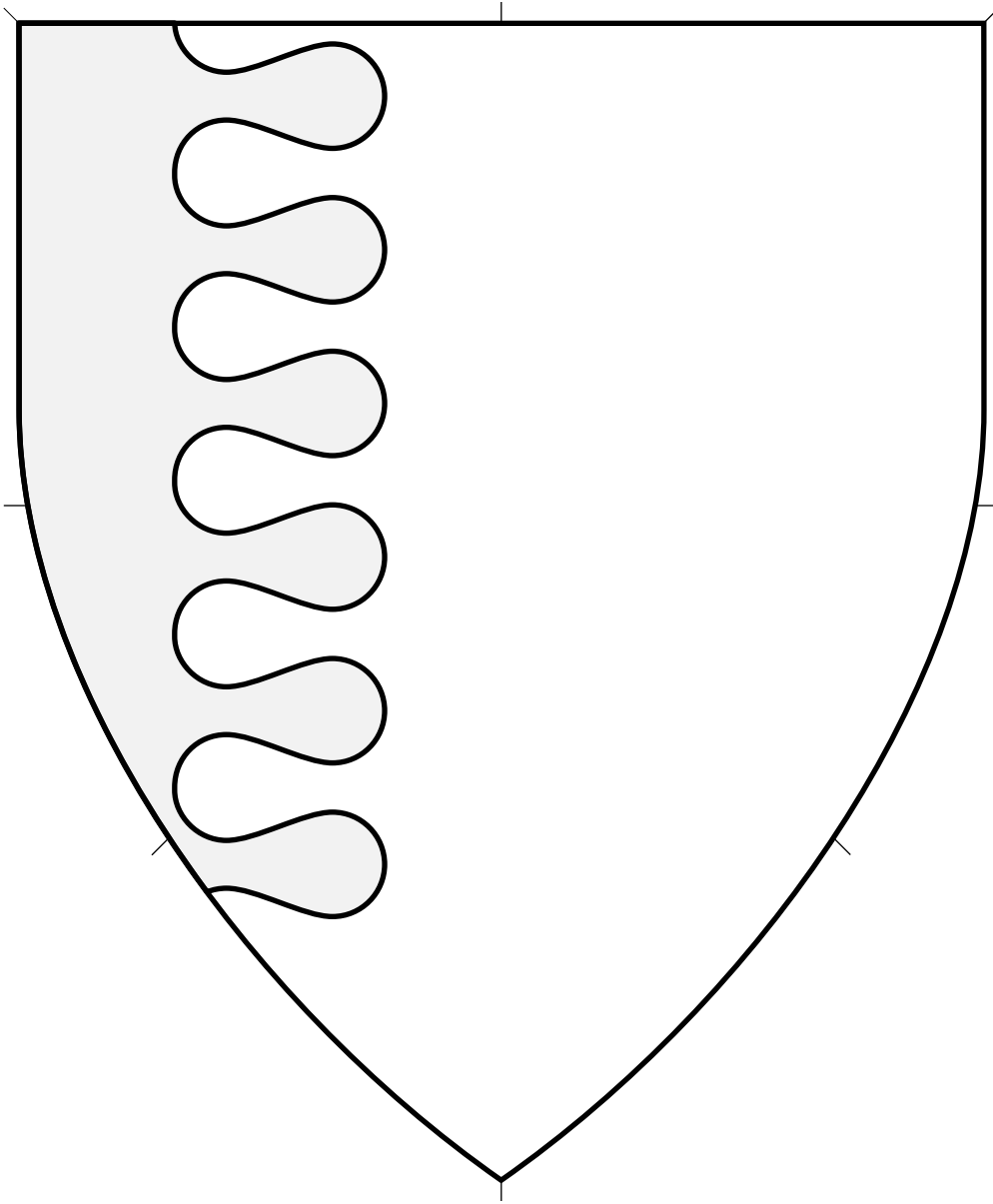

Peripheral ordinary.

Tierce Nebuly (2) 4.606

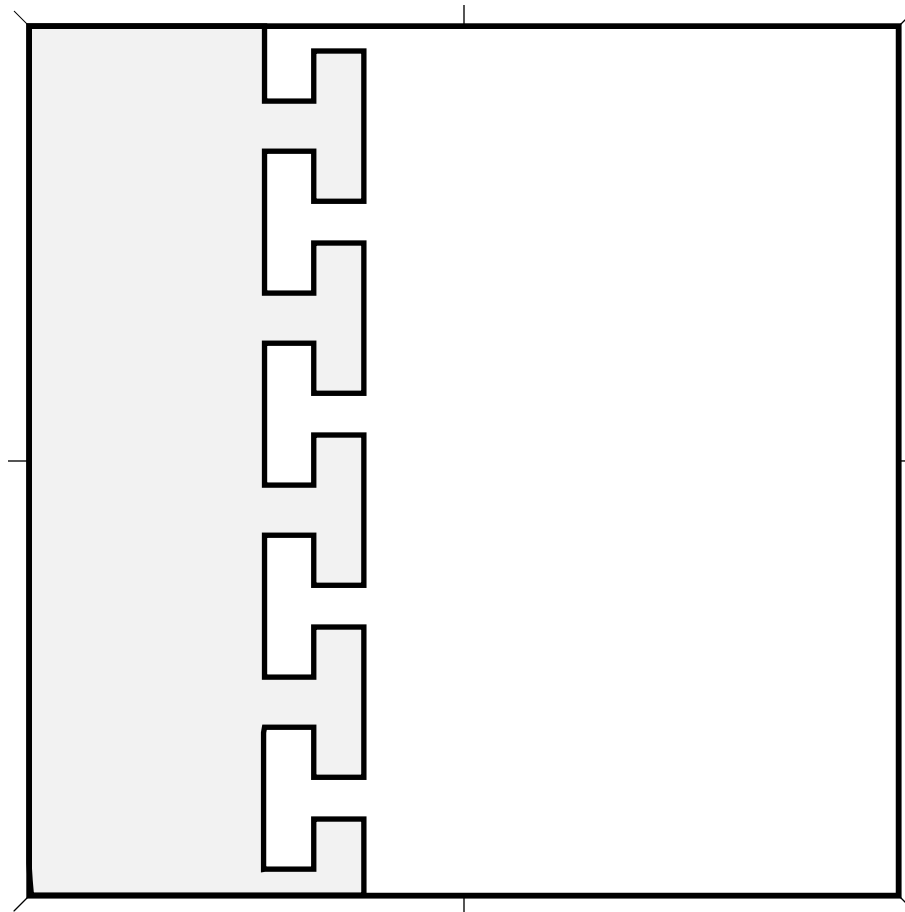
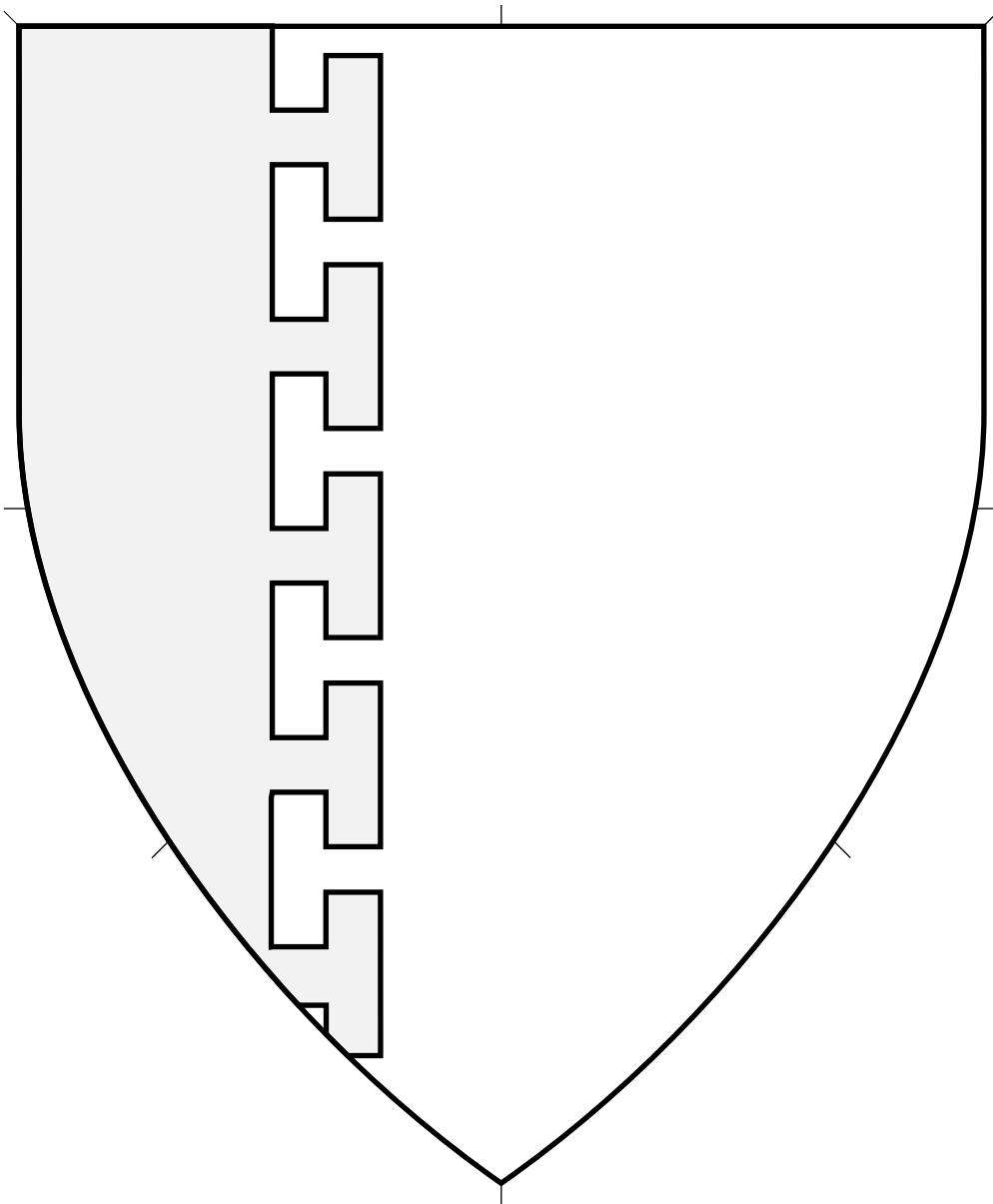

Peripheral ordinary.
Artist: Gunnvôr silfrahárr.

Tierce Potenty • 4.607

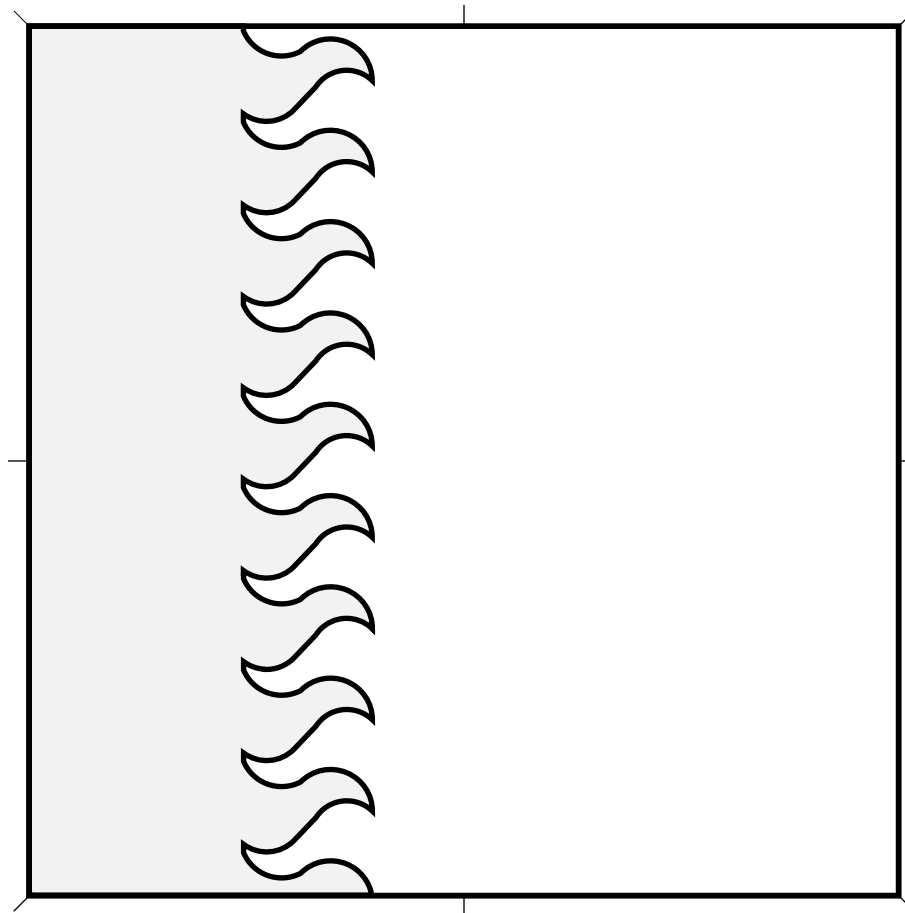
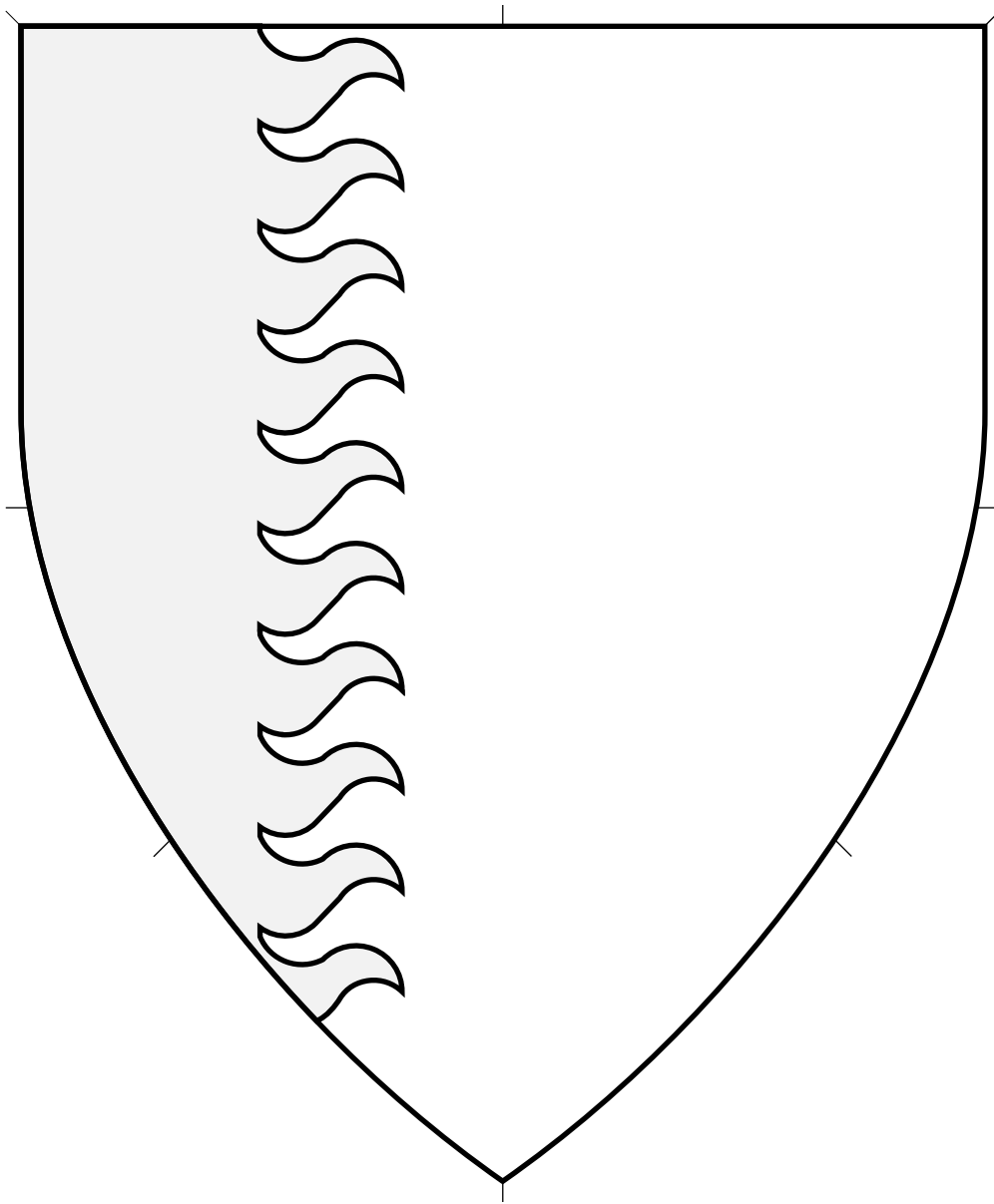

Peripheral ordinary.
Artist: Gunnvôr silfrahárr.

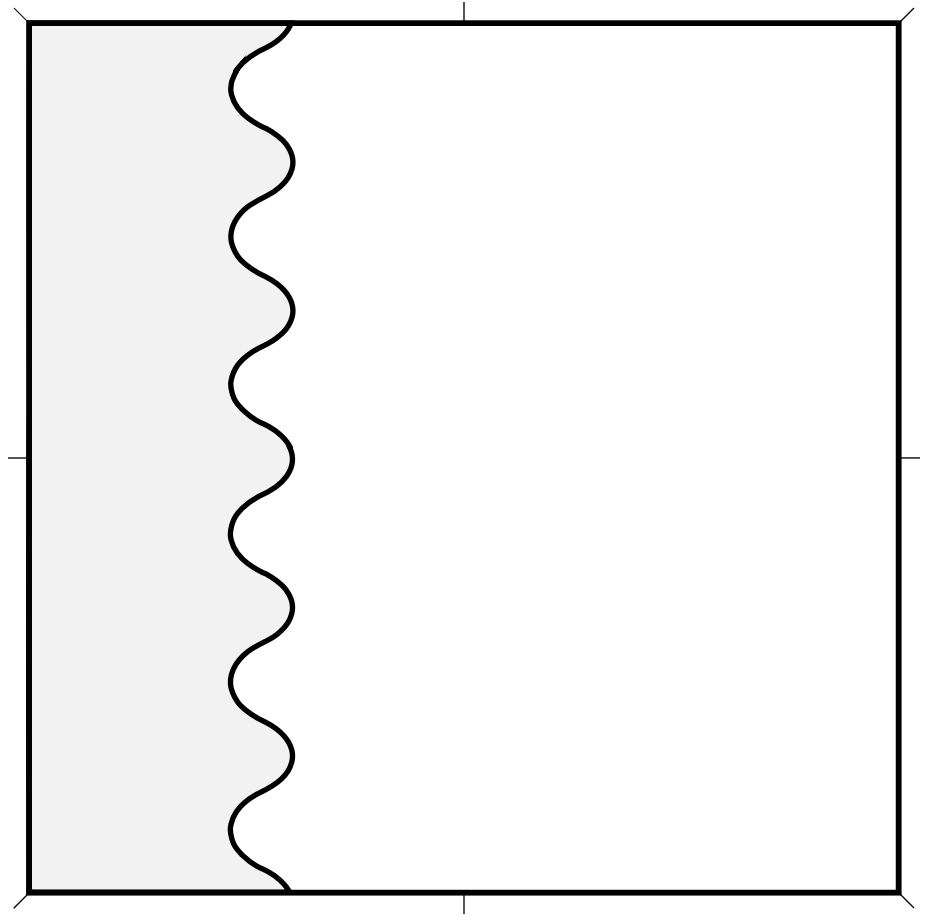
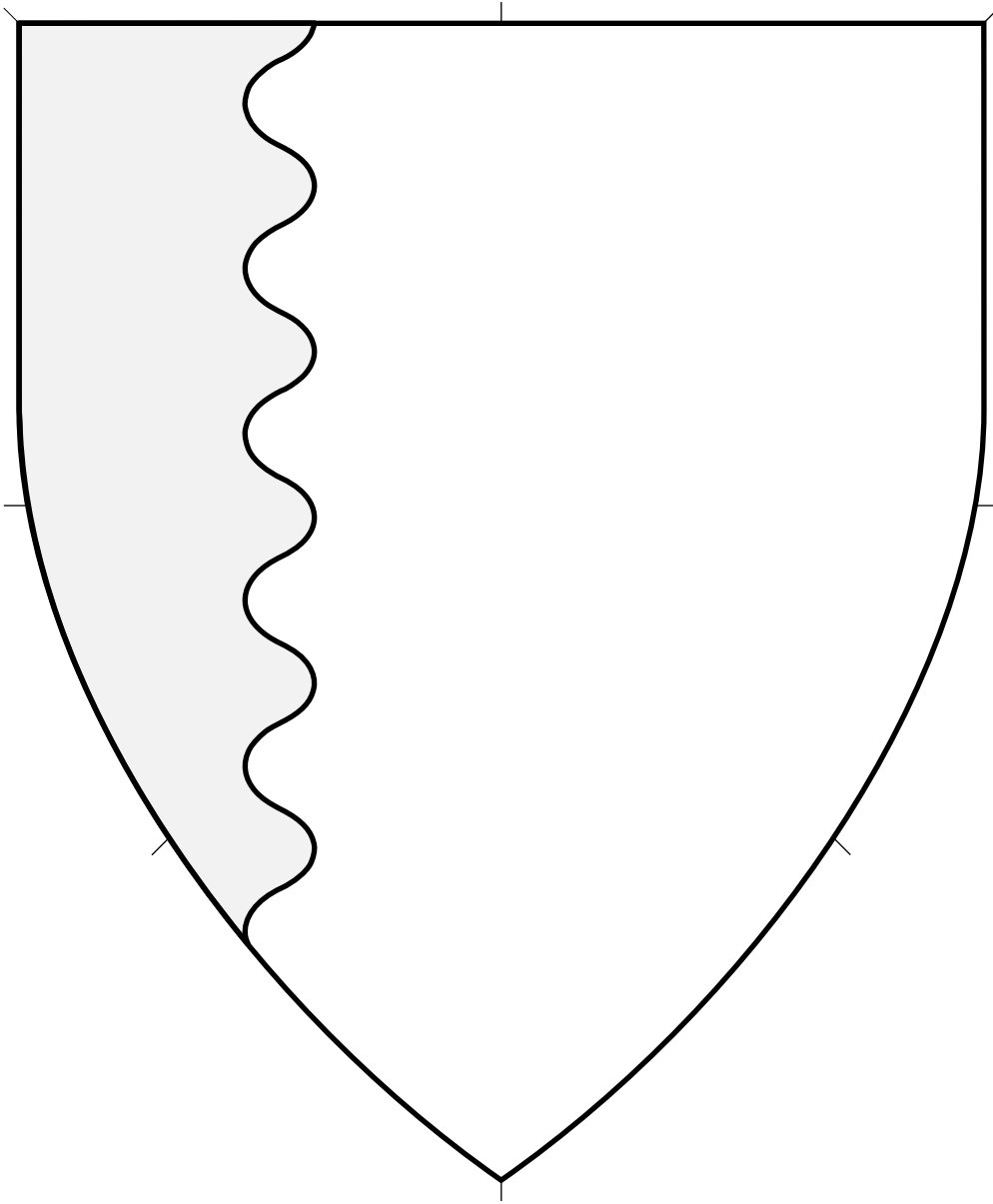

Peripheral ordinary.
Artist: Zubeydah al-Badawiyah.

Tierce Wavy • 4.609

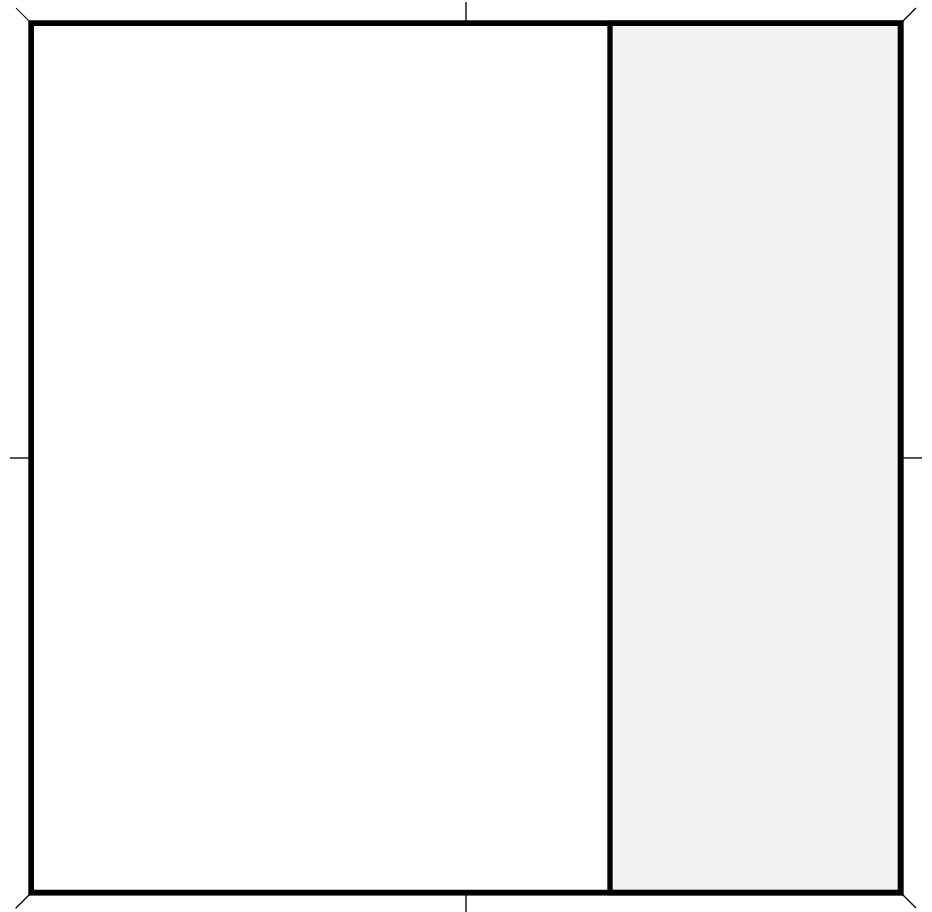
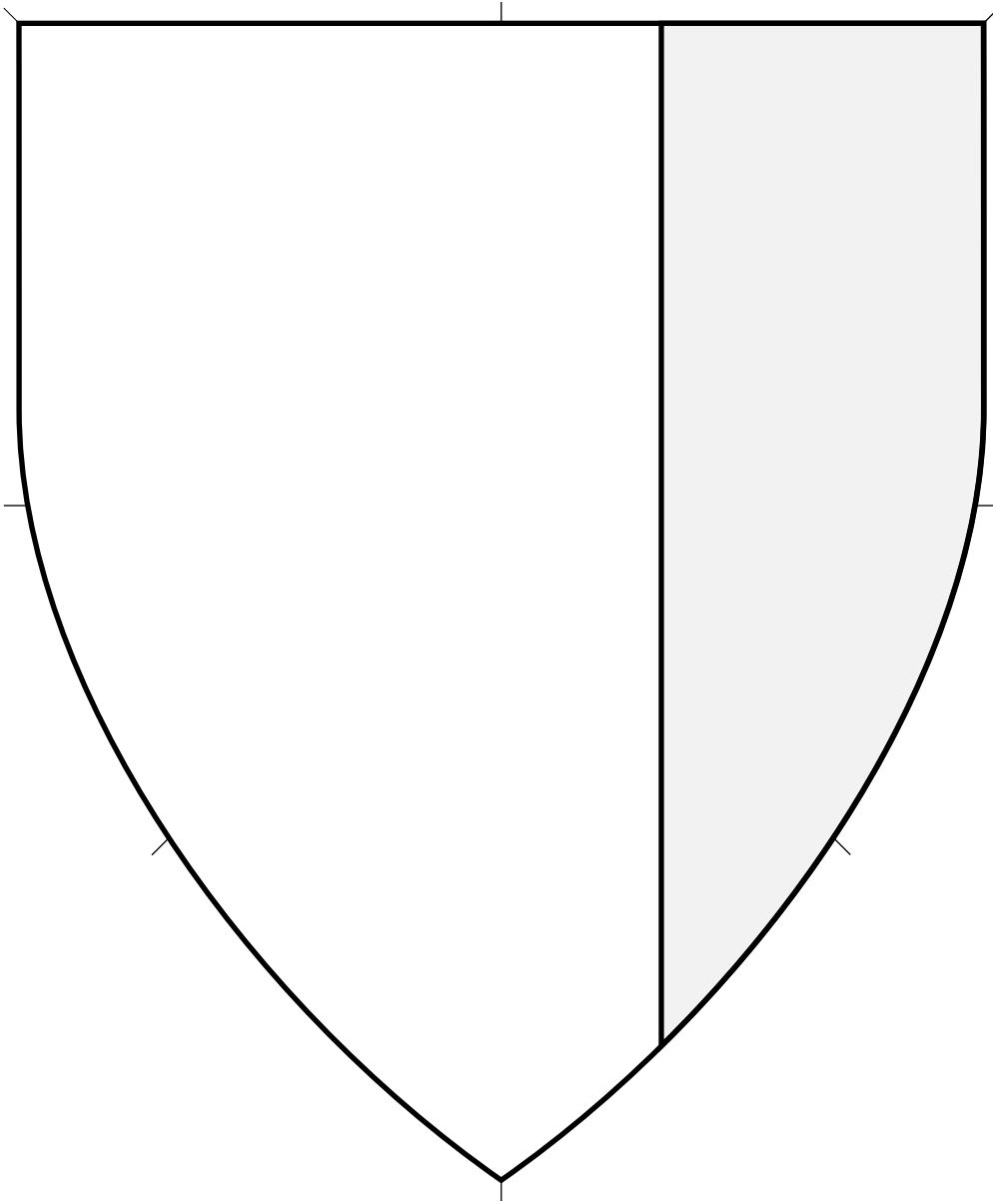

Peripheral ordinary.

May not be charged if using a plain line as shown here. A charged tierce with a complex line is registrable but would be considered a step from core practice (SFCP).

Tierce Sinister 4.610

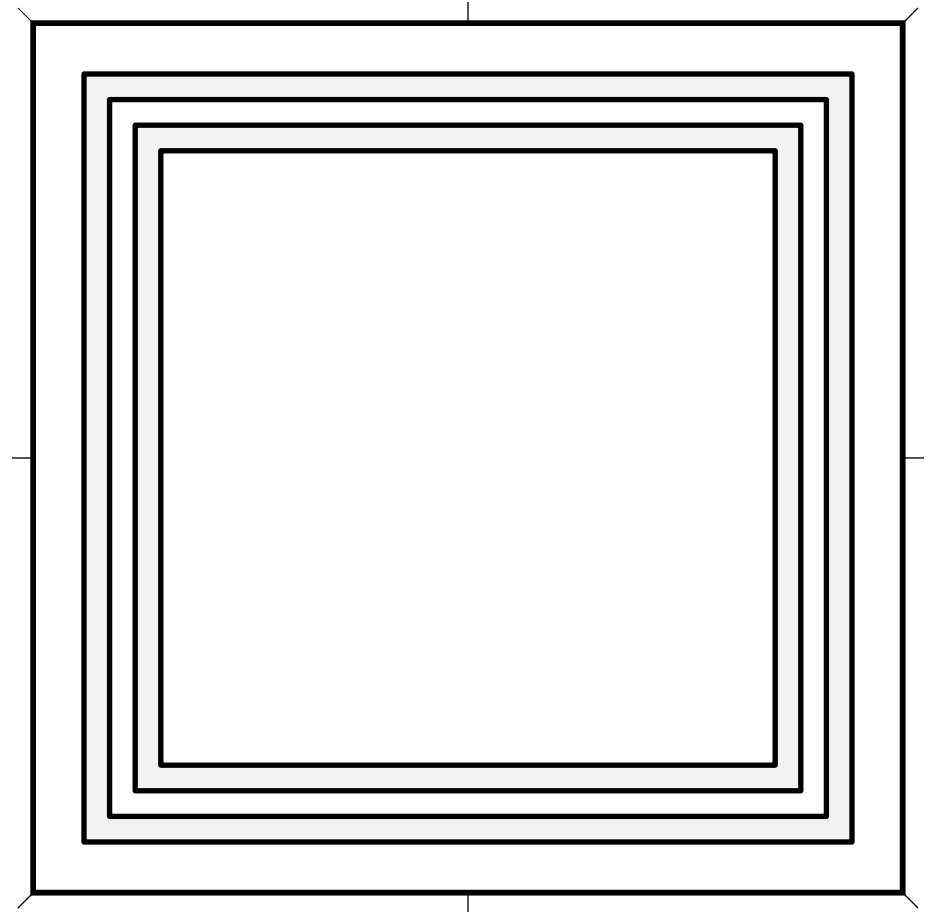
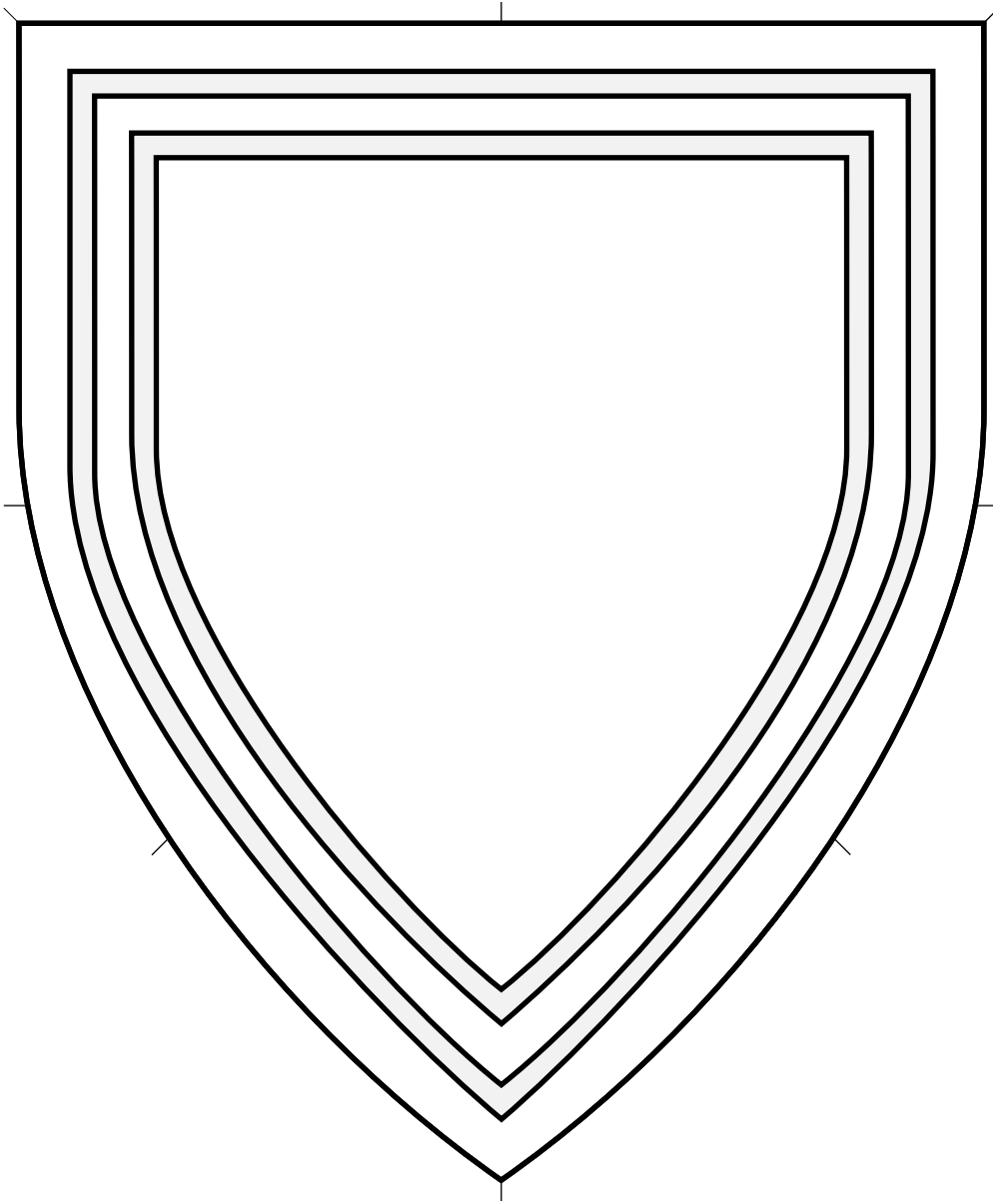

Peripheral ordinary. Diminutive of the orle. Occasionally referred to as an "orle gemel."

Gressure, Double (1) 4.611

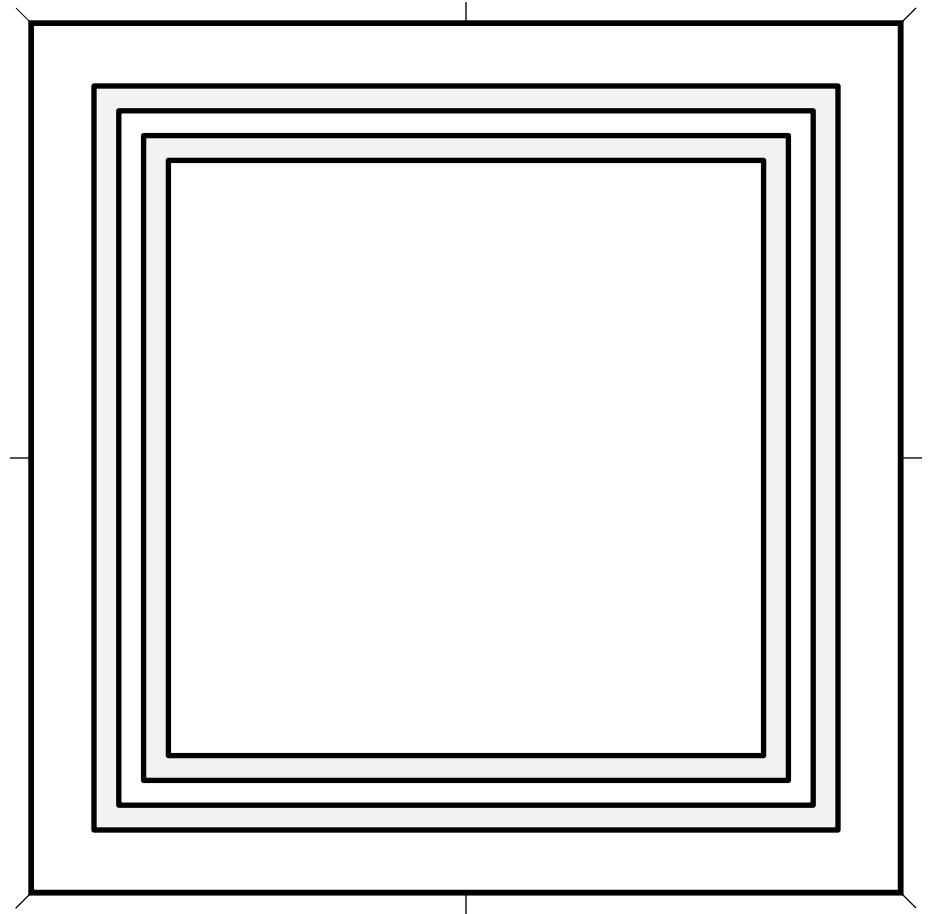
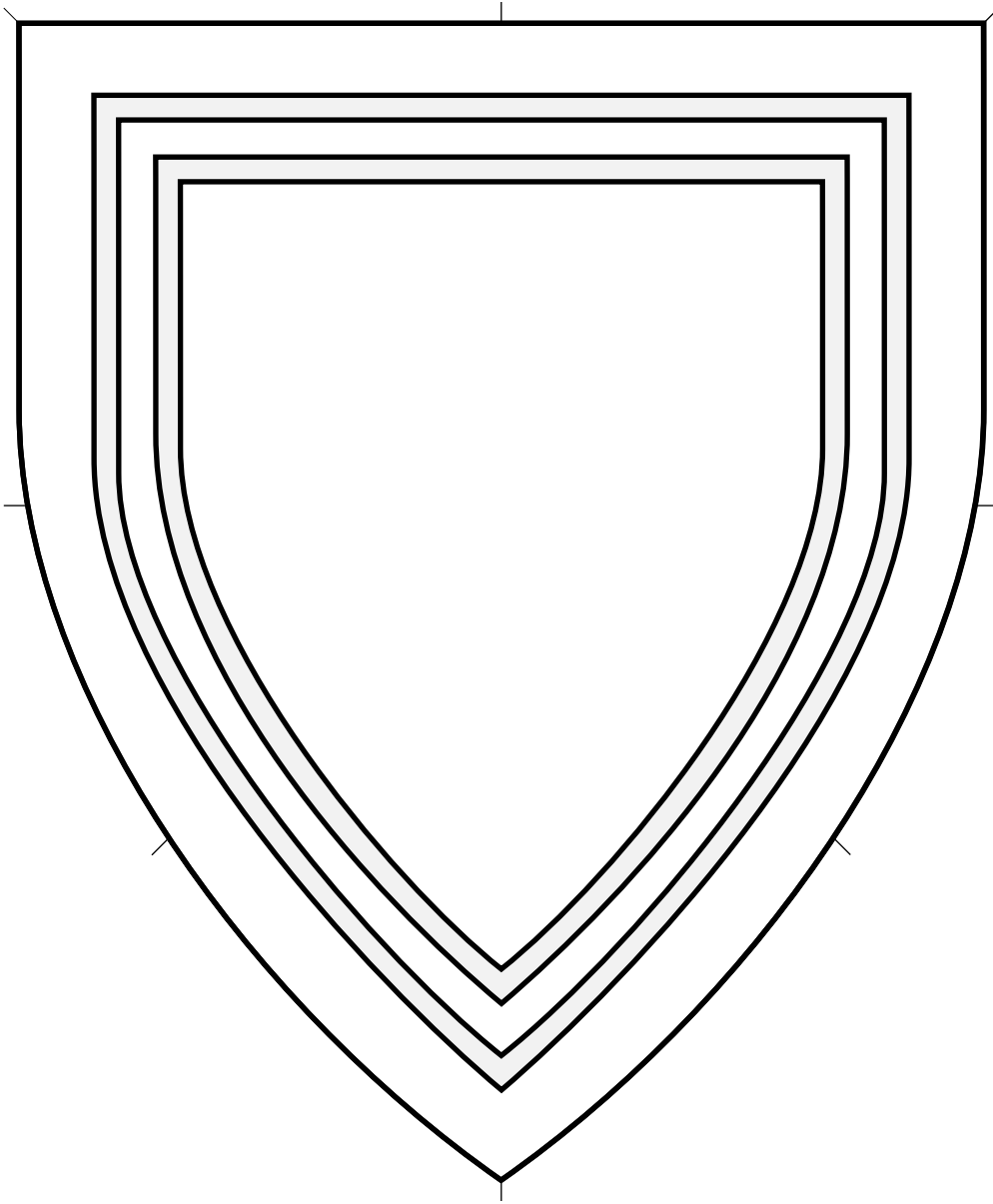

Peripheral ordinary. Diminutive of the orle. Occasionally referred to as an "orle gemel."

Pressure, Double (2) 4.612

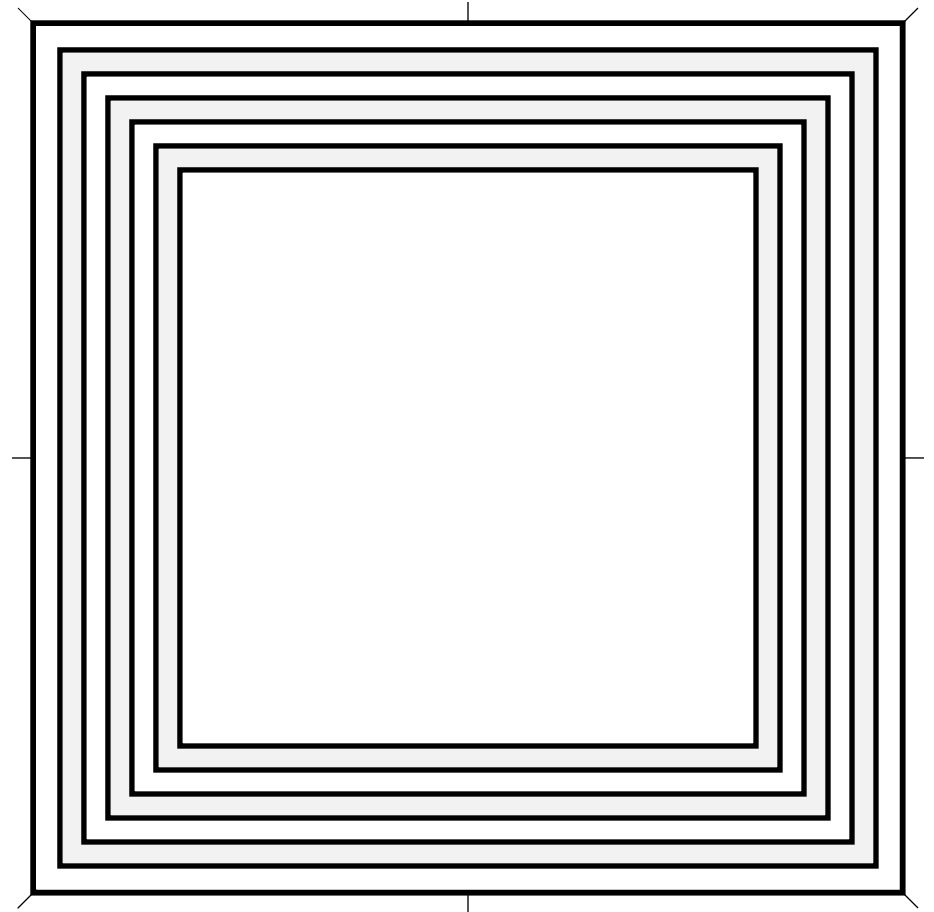
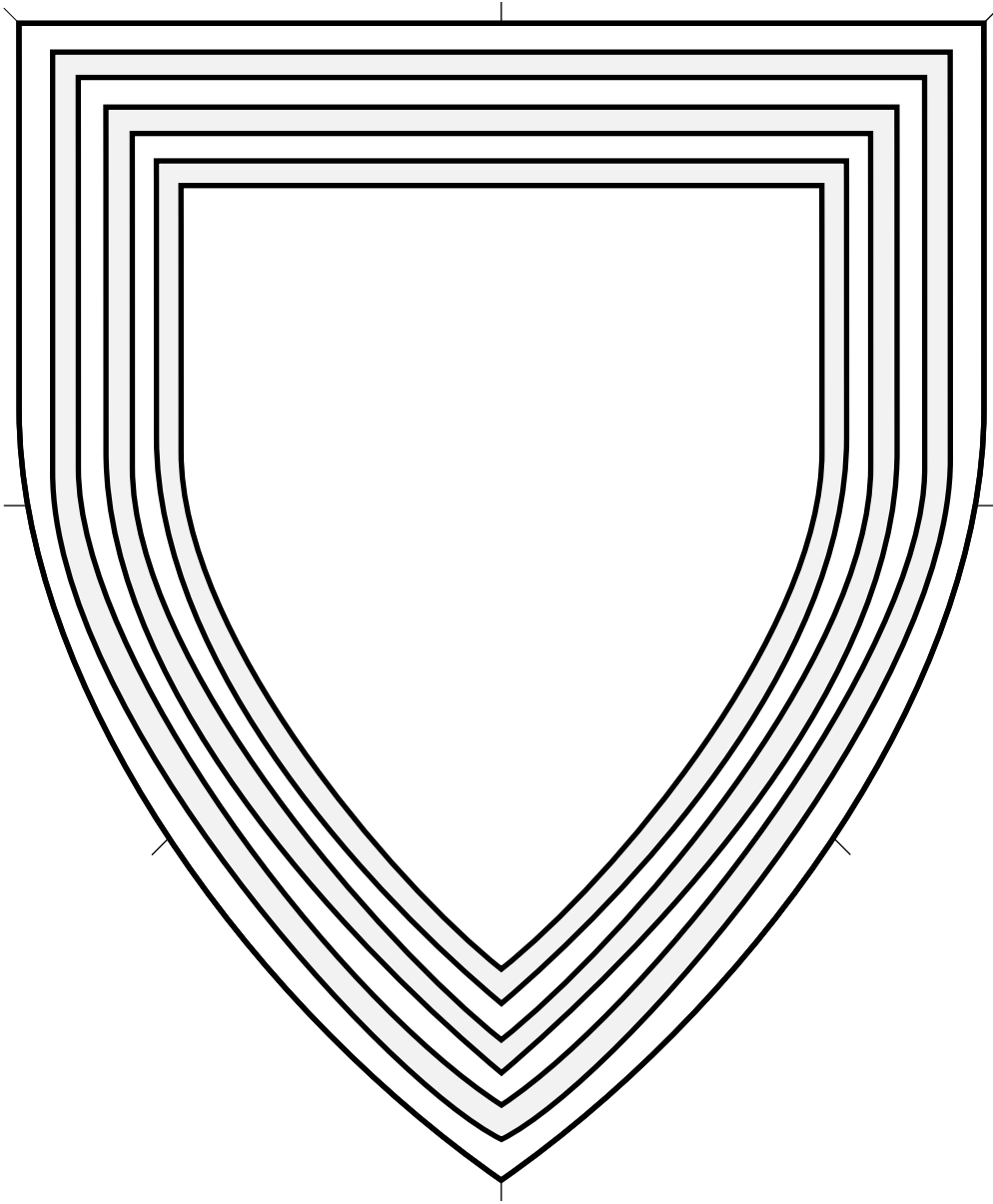

Peripheral ordinary. Diminutive of the orle.